



# **nanoCAD**

## **ENGINEERING ECOSYSTEM**

### **Version 24.0**

USER GUIDE

Nanosoft  
2024

<b>TRADEMARKS</b> .....	<b>27</b>
<b>GENERAL INFORMATION</b> .....	<b>29</b>
INTRODUCTION.....	29
MODULAR PROGRAM CONFIGURATION.....	30
SYSTEM REQUIREMENTS.....	30
PROGRAM INSTALLATION .....	31
PROGRAM REGISTRATION .....	31
LAUNCH OF NANOCAD .....	32
HELP SYSTEM .....	32
EXIT FROM NANOCAD .....	33
<b>NANOCAD USER INTERFACE</b> .....	<b>35</b>
THE NANOCAD BUTTON .....	36
QUICK ACCESS TOOLBAR .....	37
RIBBON.....	37
MAIN MENU .....	40
TOOLBARS .....	42
DRAWING WINDOW.....	43
CONTEXT MENU .....	45
PROPERTIES BAR.....	46
COMMAND LINE .....	51
<i>Input of Commands, Aliases and Shortcuts</i> .....	52
<i>Text Window</i> .....	54
<i>Command Line Prompt</i> .....	54
<i>Format of Input Data</i> .....	55
<i>Mathematical Processor</i> .....	55
<i>Auto Hide Mode in the Command Line</i> .....	57
WORKING WITH COMMANDS.....	58
<i>Transparent Commands</i> .....	59
<i>Non-dialog Mode of Commands</i> .....	59
<i>Command Recall</i> .....	60
<i>Undo-Redo Commands</i> .....	61
Undo .....	61
Redo.....	64
<i>Settings of the Right Mouse Button</i> .....	64
STATUS BAR.....	65
<i>Managing Elements of the Status Bar</i> .....	67
RESTORE UI STATE .....	68
MANAGING INTERFACE ELEMENTS .....	68
APPLICATION LOOK .....	69
COLOR THEMES.....	69
<b>WORKING WITH DOCUMENTS</b> .....	<b>70</b>
CREATION OF NEW DOCUMENT .....	71
<i>Template Usage</i> .....	71
CREATING A NEW DOCUMENT BY THE SPECIFIED TEMPLATE .....	73
OPENING A DOCUMENT .....	73
<i>Opening a Document from the Command Line</i> .....	75
<i>Replacement of Missing Font in the Document</i> .....	75
<i>Documents Protection when Sharing</i> .....	76
<i>Working with Document Tabs</i> .....	77
<i>Floating Document Window</i> .....	79
Docked Document Window.....	80
DRAWING PROPERTIES.....	80
CLOSING A DOCUMENT .....	83
SAVING A DOCUMENT.....	83
<i>Saving a Document with Another Name</i> .....	85
<i>Saving a Document or Its Part Using the WBLOCK Command</i> .....	87

<i>AutoSaving and Backup</i> .....	87
AutoSaving.....	88
Backup .....	89
Saving File History and Possibility to Return to Previous States.....	90
<i>Incremental Saving</i> .....	91
IMPORT.....	91
IMPORTING PDF FILES DATA.....	93
IMPORTING PDF UNDERLAY DATA .....	96
EXPORT.....	98
<i>Export of All Data</i> .....	99
<i>Export of Selected Data</i> .....	100
<i>Export to Stereolithography Format</i> .....	100
<i>Export to JT Format</i> .....	102
<i>Integration with CAE Fidesys</i> .....	103
Open in FidesysBundle .....	104
Export Model for Sim4Design .....	104
Download CAE Fidesys.....	104
CREATE TRANSMIT PACKAGE.....	104
CAD STANDARDS .....	108
<i>Creating a Standards File</i> .....	108
<i>Association of Standards with a Document</i> .....	109
<i>Checking Standards</i> .....	111
<i>Standards Check Options</i> .....	114
<i>Layer Translator</i> .....	116
UTILITIES.....	122
<i>Document Audit</i> .....	122
<i>Auditing Geometry</i> .....	123
<i>Recovery of Document</i> .....	125
<i>Purging of Document</i> .....	125
Purging a Document Using the Command Line .....	127
<i>Convert to 2D</i> .....	129
<i>Text Encoding Conversion</i> .....	129
<i>Batch File Processing</i> .....	134
FILE EXPLORER .....	136
<i>Actions</i> .....	138
<i>File Explorer Toolbar</i> .....	140
DRAWING COMPARISON .....	141
<b>TUNING NANOCAD</b> .....	<b>145</b>
MIGRATION OF SETTINGS FROM PREVIOUS VERSIONS .....	145
<i>Migrating Settings at Minor Update</i> .....	145
TRANSFERRING USER INTERFACE SETTINGS .....	146
<i>Exporting User Interface Settings</i> .....	146
Editing the file package composition.....	147
<i>Importing User Interface Settings</i> .....	148
TUNING PROGRAM PARAMETERS.....	149
<i>Parameters</i> .....	151
Cursor .....	151
Select .....	151
Object Highlighting .....	152
Fade Control.....	153
Grips .....	153
Color Settings.....	154
Application Look .....	154
Snap Settings .....	155
Dynamic input.....	156
Mouse Settings .....	156
3D Orbit and Free Orbit Settings .....	156
Right Button Usage.....	157
Floating windows.....	158
Command Line.....	159
System Settings.....	160

Save Documents .....	162
Undo Command Settings .....	163
Import/Export and Print Settings.....	163
Standard Directories .....	164
Template Usage .....	166
Standards Audit Usage.....	167
Papers .....	167
Raster File Formats .....	167
Text Settings .....	168
API.....	168
Feedback.....	168
ETransmit.....	169
Default Raster Properties .....	169
Georeferencing.....	169
PDF Units .....	170
Licensing .....	170
<i>Profiles.....</i>	<i>171</i>
Profile Quick Setting .....	173
GRAPHIC SUBSYSTEM SETTINGS .....	173
<i>Graphics Hardware Acceleration Settings.....</i>	<i>174</i>
Automatic Adjustment of Graphic Hardware Acceleration .....	175
OpenGL Manual Adjustment .....	177
DirectX Manual Adjustment .....	177
DirectX Version .....	178
<i>Graphic Subsystem Common Settings.....</i>	<i>178</i>
Antialiasing .....	178
Rendering optimization .....	179
Improved Compatibility Mode.....	179
CUSTOMIZE USER INTERFACE .....	180
<i>Ribbon Tab .....</i>	<i>183</i>
Tabs .....	183
Create a new tab .....	183
Create tab elements .....	184
Context tabs .....	185
Panels .....	185
Create new panel .....	185
Create panel elements .....	186
Rows .....	187
Create row elements .....	187
Quick Access Toolbar .....	190
Deleting Elements.....	190
<i>Main Menu.....</i>	<i>190</i>
Create Custom Menu.....	191
<i>Toolbars Tab.....</i>	<i>193</i>
Create New Toolbar .....	194
Toolbars Display Settings.....	196
<i>Accelerators Tab.....</i>	<i>197</i>
<i>Object Actions Tab .....</i>	<i>199</i>
<i>Status Bar Tab .....</i>	<i>200</i>
<i>Rollover Tooltips Tab.....</i>	<i>201</i>
<i>Aliases Tab .....</i>	<i>202</i>
<i>Create New Command .....</i>	<i>204</i>
<i>Create Virtual Command.....</i>	<i>206</i>
DESIGN SETTINGS .....	210
<i>Main Menus .....</i>	<i>212</i>
<i>Main Options Tab.....</i>	<i>215</i>
<i>Standard Elements Tab .....</i>	<i>223</i>
<i>Symbols Tab .....</i>	<i>223</i>
<i>Forms Tab.....</i>	<i>226</i>
<i>3D Tab .....</i>	<i>228</i>
<i>Quick Options .....</i>	<i>231</i>
<i>Settings of Layers Profiles .....</i>	<i>232</i>
<i>Saving and Transferring Settings to Another Computer.....</i>	<i>238</i>
DRAWING UNITS .....	239

SCALE LIST.....	241
SYMBOL SCALE AND MEASUREMENT SCALE .....	244
<i>Specifying Scale</i> .....	244
<i>Symbol Scale</i> .....	245
<i>Measurement Scale</i> .....	246
«Scale» <i>Toolbar</i> .....	248
SYSTEM VARIABLE MONITOR .....	248
<b>COORDINATE SYSTEMS.....</b>	<b>251</b>
SPECIFYING COORDINATES.....	251
<i>Cartesian Coordinates</i> .....	251
<i>Polar Coordinates</i> .....	252
<i>Specifying Points With “Direction – Distance”</i> .....	253
<i>Coordinate Filters</i> .....	254
USER COORDINATE SYSTEM .....	254
<i>Changing UCS Position</i> .....	255
World Coordinate System.....	255
Changing the UCS Position from the Command Line.....	255
Aligning UCS to an Object .....	257
Setting UCS by View.....	259
New Origin for UCS.....	259
New Origin and Rotation Angle for UCS .....	259
Changing Direction of Z-Axis in UCS.....	260
Defining a New UCS by 3 Points.....	260
Rotating UCS Around X, Y or Z Axes.....	261
Dynamic UCS.....	261
<i>UCS Icon</i> .....	265
<i>Named UCS</i> .....	266
Named UCS Tab .....	267
Orthographic UCS Tab .....	268
Settings Tab .....	270
<i>UCS for Viewports</i> .....	271
<b>PRECISION TOOLS.....</b>	<b>272</b>
PRECISION MODES.....	272
<i>Snap and Grid Mode</i> .....	273
Controlling Grid Options from the Command Line.....	278
Drawing Limits .....	278
<i>Polar Tracking Mode</i> .....	279
<i>Object Snap Mode</i> .....	282
<i>Snap to Raster Objects</i> .....	291
Settings of Raster Snap .....	291
<i>Object 3D Snap</i> .....	293
<i>Object Snap Tracking Mode</i> .....	295
<i>Display of Snap Elements</i> .....	298
<i>ORTHO Mode</i> .....	299
<i>Dynamic Input</i> .....	300
Dimension Input .....	301
Pointer Input.....	305
Dynamic Prompts .....	306
<b>GRAPHIC DISPLAY MANAGEMENT .....</b>	<b>308</b>
DISPLAY MODES .....	308
<i>Pan Command</i> .....	308
<i>Zoom</i> .....	309
Realtime.....	310
Window .....	311
Scale.....	311
Zoom 1:1.....	311
Zoom Center .....	312
Zoom All.....	312
Zoom Selected .....	312
Zoom Window .....	312

Zoom In.....	313
Zoom Out.....	313
Extents .....	313
Previous.....	313
SETTING OF THE ORTHOGRAPHIC AND ISOMETRIC VIEWS .....	314
<i>Orthographic Views</i> .....	314
Set Top.....	314
Set Bottom.....	315
Set Left.....	316
Set Right.....	316
Set Front .....	317
Set Back .....	318
<i>Isometric Views</i> .....	318
SW Isometric.....	318
SE Isometric .....	319
NE Isometric .....	320
NW Isometric.....	320
MANAGING THE DISPLAY OF ANNOTATIVE OBJECTS.....	321
3D NAVIGATION.....	322
<i>3D Orbit</i> .....	322
<i>Free Orbit</i> .....	324
<i>3D-Navigation View Modes</i> .....	325
Perspective .....	325
Orthogonality.....	325
Differences in Zooming in 3D-Projections .....	326
<i>3D-Fly</i> .....	326
<i>3D-Walk</i> .....	328
<i>Plan</i> .....	328
<i>View Cutting Planes</i> .....	329
<i>Viewport Tools for Views Management</i> .....	332
Locator.....	332
MANAGING DISPLAY OF LINE WEIGHT ON THE SCREEN .....	338
<i>Lineweight Settings Dialog</i> .....	338
MANAGING NAMED VIEWS .....	339
ORDER OF OBJECTS .....	343
<i>Bring to Front</i> .....	344
<i>Send to Back</i> .....	344
<i>Bring Forward</i> .....	344
<i>Send Backward</i> .....	344
<i>Bring Texts to the Front</i> .....	344
<i>Bring Dimensions to the Front</i> .....	345
<i>Bring Texts and Dimensions to the Front</i> .....	345
<i>Send Hatches to the Back</i> .....	345
CONTROL THE OBJECTS VISIBILITY .....	345
<i>Objects Isolation</i> .....	345
<i>Isolate Objects</i> .....	347
<i>Hide Objects</i> .....	347
<i>Undo Isolation Step</i> .....	347
<i>Redo Isolation Step</i> .....	348
<i>Unisolate Objects</i> .....	348
<i>Bounding Prism</i> .....	348
<i>Bounding Prism by Object</i> .....	353
VIEWPORTS OF MODEL SPACE .....	353
1 Viewport.....	354
2 Viewports Vertical .....	354
2 Viewports Horizontal.....	354
3 Viewports .....	354
3 Viewports Horizontal .....	355
3 Viewports Vertical .....	355
3 Viewports Left.....	355
3 Viewports Right .....	356
3 Viewports Top.....	356

3 Viewports Bottom.....	356
4 Viewports .....	356
Named Viewports.....	357
Managing Viewports from the Command Line .....	360
VISUAL STYLES.....	361
Feature of 2D Wireframe Visual Style .....	365
Visual Styles Manager.....	365
ISOMETRIC DRAFTING .....	371
DRAWING REGENERATION .....	375
Regeneration.....	375
Redrawing .....	376
<b>OBJECTS' PROPERTIES.....</b>	<b>377</b>
"PROPERTIES" BAR .....	377
Change Object Properties Command .....	380
Creation of Custom Properties Fields .....	381
DRAWING EXPLORER .....	384
Objects in the current document space.....	385
Objects of the Current Document Space .....	389
Named Objects of a Drawing .....	391
SELECT COLOR DIALOG BOX.....	396
Index Color Tab.....	396
True Color Tab.....	397
DISTRIBUTING OBJECTS BY LAYERS .....	399
LAYERS .....	400
Editing a Layer's Parameters.....	405
To Select Layers in the Dialog Box .....	405
Search for Layers by Name .....	405
To Sort Layers by Property.....	406
Specifying the Color, Type and Width of Lines in the Layer.....	406
Creation of a New Layer .....	407
Renaming a Layer .....	407
Removing a Layer.....	407
Removing of Used Layers.....	407
Making a Layer Active.....	409
Controlling Layer Visibility .....	409
Freezing a Layer .....	409
Freezing Layers in the Viewports of a Layout .....	410
Command to manage frozen layers in individual viewports .....	411
Redefinition of Layer's Properties in Viewports .....	412
Lock a Layer .....	414
Controlling Layer Printability .....	414
View Mode of Selected Layers.....	415
Creating and Editing Group of Layers .....	416
Creation of a New Group of Layers.....	416
Editing a Group of Layers.....	417
Creating and Editing Filters .....	417
Creation of a New Filter.....	417
Editing Layers Filter .....	418
"All Used Layers" Filter .....	419
All Layers without xrefs Filter .....	419
"Invert Layers" Checkbox.....	420
Configurations of Layers.....	420
Layer State Manager.....	422
LAYERS FUNCTIONAL BAR .....	424
Table view of the list of layers.....	426
Tree view of the list of layers.....	427
Search for Layers by Name.....	428
Creating a New Layer .....	429
Deleting a Layer .....	429
View mode for selected layers (layer walk).....	431
Layer Settings.....	431

<i>Sorting Layers</i> .....	432
<i>Editing Layer Parameters</i> .....	432
Selecting layers from the list.....	432
Renaming a Layer.....	432
Setting a Layer Current.....	432
Assigning Properties to a Layer.....	433
Managing a Layer Visibility.....	433
Freezing a Layer.....	434
Freezing Layers in Layout Viewports.....	434
Overriding Layer Properties in Viewports.....	435
Locking a Layer to Make Changes.....	436
Managing Layer Availability for Plotting.....	437
<i>Tools to Work with Layers</i> .....	437
<i>Create Layer</i> .....	438
Make Object's Layer Current.....	439
Layer Walk.....	439
Match Layer.....	440
Change to Current Layer.....	441
Copy Objects to New Layer.....	442
Isolate.....	443
Layer Off.....	444
Turn on All Layers.....	446
Layer Freeze.....	446
<i>VP Freeze Layer in All Viewports Except Current</i> .....	448
Thaw All Layers.....	449
Layer Lock.....	449
Layer Unlock.....	449
Merge Layer.....	450
Delete Layer.....	450
<i>Previous State of Layers</i> .....	451
LINE TYPES.....	451
<i>Edit Linetype</i> .....	455
<i>Creation of a New Linetype</i> .....	459
<i>Brief Description of the Procedure for Creating Custom Linetypes</i> .....	459
MANAGING THE TRANSPARENCY OF OBJECTS.....	464
<b>GEOMETRIC OBJECTS.....</b>	<b>465</b>
CONSTRUCTION AND REFERENCE GEOMETRY.....	465
<i>Point</i> .....	465
Size and Style of Points.....	466
<i>Infinite Lines</i> .....	467
Ray.....	467
Construction Line.....	468
LINEAR OBJECTS.....	469
<i>Line by Two Points</i> .....	469
<i>Polyline</i> .....	470
<i>3D Polyline</i> .....	472
<i>Multiline</i> .....	473
Multiline Styles.....	474
Save Multiline Styles.....	477
Load Multiline Styles.....	478
<i>Polygon</i> .....	478
<i>Rectangle</i> .....	479
Rectangle by Two Points.....	479
Creating a Rectangle from Center.....	481
Rectangle by Three Points.....	484
CURVED OBJECTS.....	484
<i>Arc</i> .....	484
Arc by Three Points.....	485
Arc by Center, Start and End.....	485
Arc by Continue.....	486
Arc by Start, Center and End.....	486
Arc by Start, Center and Angle.....	487
Arc by Start, Center and Chord Length.....	487



Arc by Start, End and Angle .....	487
Arc by Start, End and Direction.....	488
Arc by Start, End and Radius.....	488
Arc by Start, Radius and Tangent.....	489
Arc by Center, Start and Chord Length .....	489
Arc by Center, Start and Angle.....	490
Arc by Center, Angles and Radius .....	490
<b>Circle.....</b>	<b>491</b>
Circle by Center and Radius .....	491
Circle by Two Tangents and Radius .....	492
Circle by Center and Diameter.....	492
Circle by Diameter .....	493
Circle by Three Points .....	493
Circle by Three Tangents .....	494
<b>Donut.....</b>	<b>494</b>
<b>Spline.....</b>	<b>495</b>
Creating Splines by Fit Points Method .....	496
Creating Splines by Control Vertices Method .....	497
Converting Objects to Spline .....	497
<b>Ellipse .....</b>	<b>497</b>
Ellipse by Semi-axes.....	497
Ellipse by Axis and Semi-axis.....	498
Elliptic Arc .....	499
Creation of Ellipses and Elliptic Arcs with One Command .....	500
Creation of Isocircle and Isoarc.....	500
<b>Helix.....</b>	<b>501</b>
<b>Add Selected.....</b>	<b>502</b>
<b>EDITING OBJECTS.....</b>	<b>503</b>
SELECTION OF OBJECTS .....	503
<i>Selection of Objects Using the Command Line .....</i>	<i>506</i>
<i>Selection of All Objects.....</i>	<i>508</i>
<i>Remove from Selection.....</i>	<i>508</i>
<i>Leave in Selection .....</i>	<i>508</i>
<i>Invert Selection.....</i>	<i>509</i>
<i>Select Similar Objects .....</i>	<i>509</i>
<i>Selection of Overlaid Objects.....</i>	<i>510</i>
<i>Selection of Objects Using the Properties Bar .....</i>	<i>512</i>
Mode and Commands to Select Objects.....	512
To Remove Objects from a Selection Set.....	513
To Leave Objects in a Selection Set .....	514
<i>Quick Selection of Objects .....</i>	<i>514</i>
"Quick select" Functional Bar .....	519
WAYS TO EDIT OBJECTS .....	520
<i>Copy of Objects Properties .....</i>	<i>520</i>
<i>Copying and Insertion of Objects Using Clipboard .....</i>	<i>522</i>
Cut .....	523
Copy.....	523
Copy With Base Point .....	523
Copy OLE-Link .....	524
Paste .....	524
Paste as Block .....	525
Paste as Raster.....	525
Paste to Original Coordinates .....	526
Paste Special .....	526
Copying Objects and Creating a Block by Dragging with the Right Mouse Button .....	527
<i>Editing Objects Using Ordinary Grips .....</i>	<i>528</i>
Movement, Rotation, Scale, Mirror .....	529
Modified Copies Using Ctrl .....	530
Grips Settings.....	530
<i>Editing Objects Using Multifunctional Grips .....</i>	<i>531</i>
Segment Editing.....	532
Arc Editing.....	533
Polyline Editing .....	533

Spline Editing .....	535
Editing 3D-Polyline.....	536
Editing Viewports in Paper Space .....	537
Editing Hatch and Fill .....	538
<i>Editing Polyline Segments</i> .....	540
COMMANDS TO EDIT OBJECTS GEOMETRY .....	541
<i>Lengthen Objects</i> .....	541
<i>Trim Vectors</i> .....	542
<i>Smart Trim</i> .....	544
<i>Extend Vectors</i> .....	546
<i>Break Vectors</i> .....	547
Break of Object in Two Points.....	548
Break of Object in One Point .....	548
<i>Break Vectors at Point</i> .....	549
<i>Break All Vectors at Point</i> .....	549
<i>Reverse</i> .....	549
<i>Join Objects</i> .....	550
<i>Editing a Polyline</i> .....	552
<i>Editing a Spline</i> .....	554
Simplify Spline .....	556
COMMANDS TO EDIT AND REPLICATE OBJECTS .....	557
<i>Erase</i> .....	557
<i>Copy</i> .....	557
<i>Mirror</i> .....	559
<i>Offset</i> .....	560
<i>Arrays</i> .....	562
Associative Arrays.....	562
Rectangular Array.....	562
Polar Array.....	566
Path Array.....	568
Editing an Array .....	570
<i>2D Arrays</i> .....	573
Rectangular 2D Array.....	574
Polar 2D Array.....	575
ARRAY Command (non-dialog option).....	577
<i>3D Arrays</i> .....	578
Rectangular 3D Array.....	578
Polar 3D Array .....	579
<i>Deleting Duplicate Objects</i> .....	580
<i>Move</i> .....	581
<i>Rotate</i> .....	582
<i>Scale</i> .....	583
<i>Stretch</i> .....	585
<i>Align</i> .....	586
<i>Distributing Copies</i> .....	587
Divide.....	587
Measure.....	588
<i>Chamfer</i> .....	589
Chamfer Command, Non-dialog Option .....	594
<i>Fillet</i> .....	595
Fillet Command (Non-dialog Mode) .....	600
<i>Explode</i> .....	601
<i>Explode Geometry</i> .....	601
<i>Explode All Objects</i> .....	602
<b>CREATING AND EDITING COMPLEX OBJECTS .....</b>	<b>603</b>
GROUPS OF OBJECTS .....	603
<i>Using Drawing Explorer Bar to Work with Groups</i> .....	604
<i>Object Grouping Dialog</i> .....	606
BLOCKS.....	610
<i>Creating a Block</i> .....	611
<i>Block Insertion</i> .....	613

<i>Editing Block Definition (Block Redefinition)</i> .....	615
Block Editor.....	616
Completion of work.....	619
3D Block Editor .....	619
<i>Block Attributes</i> .....	621
Creating Block Attributes.....	622
Editing Values of Attributes in a Block Reference.....	625
Editing Attributes of a Block Reference .....	626
Block Attribute Manager .....	628
In-Place Attribute Editing.....	632
Editing Block Attribute Definitions .....	632
Synchronizing Attributes of Block References .....	633
Controlling Display of All Block Attributes in a Document.....	633
Extracting Data from Attributes.....	634
Converting block attributes to text.....	635
<i>Exploding a Block Reference</i> .....	636
<i>Reset Block</i> .....	636
<i>Managing Blocks in the Current Drawing</i> .....	636
<i>Saving a Block in a Separate File</i> .....	637
PROXY OBJECTS.....	639
<i>Removing Proxy Objects</i> .....	639
<i>Exploding Proxy Objects</i> .....	640
INSERT EXTERNAL REFERENCE.....	640
EDIT REFERENCES.....	644
<i>Add Objects to the Working Set</i> .....	647
<i>Remove Objects from the Working Set</i> .....	647
<i>Save External Reference Changes</i> .....	647
<i>Discard External Reference Changes</i> .....	648
EXTERNAL REFERENCES MANGER.....	648
EXTERNAL REFERENCES CONTROL (CLASSIC VERSION) .....	651
<i>Change of an External Reference to a Raster Image</i> .....	657
TIFF Saving Options.....	658
JPG and JPEG Saving Options.....	661
<i>Bind External References</i> .....	661
<i>Bind Named Objects of External References</i> .....	662
<i>External References Notification</i> .....	664
<i>Renaming Named Objects</i> .....	665
BINDING AND EMBEDDING OLE-OBJECTS.....	667
<i>Insert OLE-Object</i> .....	668
<i>Open OLE-Object</i> .....	668
<i>Update OLE-Links</i> .....	669
<i>Update All OLE-Links</i> .....	669
UNDERLAYS .....	670
<i>Insert Underlay</i> .....	670
SHOW BOUNDARY .....	672
<i>Show Clip</i> .....	673
<i>Show Clipping Borders</i> .....	673
<i>Setting Clip</i> .....	674
<i>Setting of the Show Boundary for the Block or External Reference</i> .....	675
<i>Setting of the Show Boundary for a Raster Image</i> .....	678
<i>Setting Viewport Border for Underlay</i> .....	682
INSERT MAP UNDERLAY .....	684
<i>Clip Map Underlay</i> .....	695
<i>Unload Map Underlay</i> .....	695
<i>Load Map Underlay</i> .....	696
HYPERLINKS .....	697
<i>Add Hyperlinks to the Document</i> .....	697
The “Existing File or Web Page” Tab.....	697
The “View of This Drawing” Tab .....	699
The “E-mail Address” Tab .....	700
<i>Edit Hyperlinks</i> .....	700

<b>WORKING WITH RASTER IMAGES .....</b>	<b>702</b>
INSERT RASTER IMAGE .....	702
CREATE NEW IMAGE AND RASTERIZE OBJECTS.....	705
<i>New Image from Selection</i> .....	705
<i>Save Objects to a File</i> .....	709
<i>Save Screenshot to a File</i> .....	710
<i>Create New Raster Image</i> .....	711
SEPARATE RASTER IMAGE .....	711
EMBED RASTER IMAGE.....	712
IMAGE SETTINGS .....	713
DISPLAYING QUALITY OF RASTER IMAGES .....	713
<i>Image Adjust</i> .....	713
<i>Quality of Raster Images</i> .....	715
<i>Transparency of Raster Images Background</i> .....	716
CORRECTING RASTER IMAGE GEOMETRY .....	717
<i>Resizing a Raster Image</i> .....	717
<i>Changing Image Resolution</i> .....	718
<i>Editing of Raster Images</i> .....	720
Cropping of Raster Images.....	720
Automatic crop .....	720
Auto crop by frame.....	721
Crop by Rectangle.....	721
Crop by clip .....	721
Mirroring.....	722
Rotation .....	722
Deskewing.....	723
Correction by Four Points .....	724
<i>Calibration</i> .....	727
COLOR CORRECTION .....	733
<i>Conversion to True Color, Grayscale and 256 Colors</i> .....	733
Conversion to True Color (Full Color) .....	733
Conversion to Grayscale .....	734
Conversion to the Indexed Colors.....	734
<i>Changing Brightness, Contrast, Hue and Saturation</i> .....	736
<i>Correction by Histogram</i> .....	737
<i>Gamma Correction</i> .....	738
<i>Editing Color Palette (Color Classifier)</i> .....	740
FILTERING COLOR RASTER IMAGES .....	742
<i>Blur</i> .....	742
<i>Adaptive Blur</i> .....	743
<i>Contour Sharpness</i> .....	743
<i>Median</i> .....	744
COLOR REDUCING .....	745
<i>Binarization</i> .....	745
<i>Adaptive Binarization</i> .....	750
<i>Color Separation</i> .....	751
<i>Color Reduction</i> .....	754
MONOCHROME FILTERING .....	754
<i>Removing "Speckle"</i> .....	754
<i>Filling "Holes"</i> .....	755
<i>Smoothing</i> .....	756
<i>Thinning</i> .....	758
<i>Thickening</i> .....	759
<i>Contour</i> .....	760
<i>Inversion</i> .....	760
SELECTION OF DATA IN RASTER IMAGES .....	761
<i>The Order of Raster Selection</i> .....	761
<i>Quantitative Raster Selection Modes</i> .....	761
<i>Basic Selection Modes</i> .....	762
<i>Object Raster Selection Methods</i> .....	762
<i>Trace Selection Methods</i> .....	763

<i>Fill Selection Methods</i> .....	764
<i>Setting Selection Options</i> .....	764
SEPARATION BY TYPE AND SIZE .....	765
RASTERIZATION .....	767
<i>Merge</i> .....	767
<i>Merge a Copy (Rasterize)</i> .....	768
RASTER DRAWING.....	768
<i>Pixel drawing</i> .....	768
<i>Floodfilling</i> .....	769
<i>Editing Raster Text</i> .....	770
DIGITIZING RASTER DATA (VECTORIZATION).....	770
<i>Trace (Semi-Automatic Vectorization)</i> .....	771
Configuring Trace.....	771
Trace Modes .....	772
Trace Methods.....	775
Trace with Automatic Detection of Object Type .....	775
Forced Trace.....	776
Trace Polyline .....	778
<i>Automatic Vectorization (Raster to Vectors)</i> .....	780
Conversion Options .....	781
Recognition tab .....	781
Options tab.....	784
Separate Tab.....	786
Trace Tab.....	790
Texts Tab .....	791
Train OCR.....	794
<b>EXECUTION OF DRAWINGS COMMANDS.....</b>	<b>797</b>
THE FILLING AND HATCH COMMANDS .....	797
<i>Hatch Dialog Box</i> .....	797
<i>Creating Hatch</i> .....	804
<i>Gradient Fill</i> .....	808
<i>Fast Hatch</i> .....	810
<i>Fast Gradient</i> .....	810
<i>Overriding Layer for New Hatches and Fills (HPLAYER)</i> .....	811
<i>Modify Hatched Areas</i> .....	811
SHAPE .....	812
BOUNDARY .....	813
REGION.....	814
SOLID .....	815
WIPEOUT .....	816
REVISION CLOUD .....	817
WORK WITH TEXT .....	818
<i>Text</i> .....	819
<i>Multiline Text</i> .....	822
Background Mask .....	830
<i>Editing Text</i> .....	832
Justification of the Text Objects .....	833
Editing the Content of the Text Objects .....	840
Editing Single Line Text.....	841
Editing Multiline Text .....	845
<i>Arc Text</i> .....	847
<i>Creating a Text Style</i> .....	850
<i>Spellchecker</i> .....	852
<i>Find and Replace Text</i> .....	855
<i>Convert Text to Multiline Text</i> .....	860
<i>Justify Text</i> .....	861
<i>Text Fit</i> .....	865
<i>Explode Text</i> .....	865
<i>Change Text Case</i> .....	866
<i>Quick Text Mode</i> .....	867
<i>Fields</i> .....	868

“Field” Dialog Box .....	869
Fields Categories and Types .....	870
Update Field .....	873
Edit Field .....	873
Convert Field to Text .....	874
DIMENSIONING .....	874
<i>Some Features of nanoCAD’s Dimensioning</i> .....	875
Set the Scale for Dimensions .....	875
Dimensioning with a Single Command .....	876
<i>Linear Dimensions</i> .....	878
Horizontal, Vertical and Aligned Dimensioning .....	878
Setting horizontal, vertical and parallel dimensions.....	879
Ordinate Dimensioning .....	883
Group Dimensioning .....	886
Base Dimensioning .....	887
Chain Dimensioning.....	888
<i>Radial Dimensions</i> .....	889
Diameter Dimensioning .....	889
Radial Dimensioning .....	891
Big Radius Dimensioning.....	892
<i>Angular Dimensions</i> .....	893
Angle Ordinate Dimension.....	895
<i>Arc Length</i> .....	895
<i>Offset Dimension</i> .....	896
DIMENSIONS EDITING .....	897
<i>Oblique Dimension</i> .....	902
<i>Break and Restore Dimensions</i> .....	903
Dimension Break.....	903
Dimension Restore .....	904
Breaking and Unbreaking a Dimension in the Command Line.....	904
<i>Explode Dimensions</i> .....	904
DIMENSION STYLES .....	905
<i>Modify a Dimension Style</i> .....	908
The “Lines” Tab.....	909
The “Symbols and Arrows” Tab .....	911
The “Text” Tab .....	913
The “Fit” Tab.....	916
The “Primary Units” Tab .....	917
The “Alternate Units” Tab.....	920
The “Tolerances” Tab.....	922
MULTILEADER .....	925
<i>Creating a Multileader</i> .....	925
<i>Removing Leader Lines from the Multileader</i> .....	927
<i>Adding Leader Lines to the Multileader</i> .....	927
<i>Aligning Multileaders</i> .....	927
<i>Collecting Multileaders</i> .....	928
<i>Multileader Style Manager</i> .....	929
Modifying Multileader Style .....	931
NOTES .....	934
<i>Mechanical Note</i> .....	934
<i>Construction Note</i> .....	938
<i>Comb Leader Note</i> .....	940
<i>Section Note</i> .....	943
<i>Note for Multilayered Constructions</i> .....	944
<i>Node Note</i> .....	946
<i>Linear Aligned Note</i> .....	948
<i>Chain Note</i> .....	950
<i>Editing the Leaders</i> .....	952
Detach Leader.....	953
Append Leader .....	953
Edit Leader.....	954
<i>Advanced Grips for Design Elements</i> .....	954
Mechanical Note.....	955

Construction Note .....	955
Comb Leader Note .....	956
Section Note .....	957
Note for Multilayered Constructions .....	957
Node Note .....	958
Linear Aligned Note .....	958
Chain Note .....	959
Table .....	960
<b>TABLES .....</b>	<b>960</b>
<i>Editing Tables on the Drawing</i> .....	967
<i>Interface of the Table Editor Dialog</i> .....	969
Filling of adjacent cells with data .....	971
Cell colors .....	972
Basic Tools .....	973
Cell Properties .....	977
Editing the Size of Rows and Columns .....	978
Work with MS Excel .....	979
Importing a Table from Excel .....	979
Exporting a table to Excel .....	979
Page Division .....	980
Convert Tables .....	984
Cell Properties .....	984
Snap to cell .....	994
Expression Builder Interface .....	996
Formula Templates .....	998
Snap to objects .....	999
Functions in the Expression Builder .....	999
Report Creation .....	1002
Grouping and Merging Cells .....	1007
<i>Insert Material</i> .....	1013
.DWG TABLES .....	1014
<i>Inserting .dwg Tables</i> .....	1014
<i>Table Styles .dwg</i> .....	1016
Modifying Table Style .....	1017
<b>GETTING INQUIRY .....</b>	<b>1020</b>
<i>Measuring Distance and Angles</i> .....	1020
<i>Point Coordinates</i> .....	1020
<i>Cumulative Length</i> .....	1021
<i>Calculating an object's area</i> .....	1021
<i>Cumulative Area</i> .....	1022
<i>Displaying Data on Selected Objects Properties</i> .....	1022
<i>Inquiry</i> .....	1023
<i>Mass Properties of 3D-Solids and Regions</i> .....	1025
<i>Set Variable</i> .....	1026
<b>CALCULATOR .....</b>	<b>1027</b>
<b>NOTEPAD .....</b>	<b>1028</b>
<b>FEATURES OF THE DESIGN ELEMENTS .....</b>	<b>1032</b>
<i>Commands for Editing nanoCAD's Objects</i> .....	1032
The "Edit" Command .....	1032
The "Fedit" Command .....	1033
<i>The "In Place Edit" Command</i> .....	1034
<i>Parameters Redefinition</i> .....	1034
<i>Regenerate</i> .....	1037
<b>3D MODELING AND VISUALISATION .....</b>	<b>1038</b>
<b>SURFACES .....</b>	<b>1038</b>
<i>Box</i> .....	1038
<i>Wedge</i> .....	1039
<i>Cone</i> .....	1040
<i>Sphere</i> .....	1041
<i>Torus</i> .....	1042
<i>Pyramid</i> .....	1042
<i>Dish</i> .....	1044

<i>Dome</i> .....	1045
<i>Mesh</i> .....	1046
<i>3D Mesh</i> .....	1046
<i>3D Face</i> .....	1047
<b>3D MODULE</b> .....	1048
<i>Options 3D Tab</i> .....	1048
Common settings.....	1049
2D views.....	1052
Visible lines.....	1052
Hidden lines.....	1052
Section border.....	1053
Hatch.....	1053
3D. Pseudo section properties.....	1053
Hatch.....	1053
<i>3D History</i> .....	1053
Interface.....	1054
Objects of a tree.....	1054
<i>Modeling modes</i> .....	1056
<i>Sketch mode</i> .....	1057
Add planar sketch.....	1057
Creating a sketch without a reference to the plane.....	1058
Creating a sketch with a reference to the plane.....	1059
Properties.....	1060
Grips.....	1060
3D History.....	1060
Add assembly sketch.....	1060
Differences of the assembly sketch.....	1061
Include object to sketch.....	1061
Procedure.....	1061
Add projection to sketch.....	1062
Procedure.....	1062
Features of work.....	1064
Redefine plane for sketch.....	1065
Procedure.....	1066
Set Sketch Coordinate System.....	1066
Procedure.....	1067
Edit planar sketch.....	1068
Procedure.....	1069
End editing.....	1069
<i>Parametric modeling</i> .....	1069
3D Extrude.....	1069
Procedure.....	1069
Dialog.....	1071
Select new body.....	1072
3D History.....	1074
3D Revolve.....	1074
Procedure.....	1074
Dialog.....	1076
3D History.....	1076
3D Sweep.....	1077
Procedure.....	1077
Dialog.....	1079
3D History.....	1080
3D Loft.....	1080
Procedure.....	1080
Dialog.....	1082
Rails.....	1083
Center line.....	1085
3D History.....	1086
Rebuild 3D model.....	1087
<i>3D Solids</i> .....	1087
Box.....	1087
Procedure.....	1087
Grips.....	1089
3D History.....	1089



Cylinder.....	1089
Procedure.....	1089
Grips.....	1091
3D History.....	1091
Cone.....	1091
Procedure.....	1091
Grips.....	1093
3D History.....	1093
Sphere.....	1094
Procedure.....	1094
Grips.....	1095
3D History.....	1095
Pyramid.....	1095
Procedure.....	1096
Grips.....	1097
3D History.....	1098
Wedge.....	1098
Procedure.....	1098
Grips.....	1100
3D History.....	1100
Torus.....	1100
Procedure.....	1101
Grips.....	1102
3D History.....	1103
Polysolid.....	1103
Procedure.....	1103
Grips.....	1104
3D History.....	1104
Interfere 3D solids.....	1105
Procedure.....	1105
Extrude.....	1107
Procedure.....	1107
Grips.....	1110
Revolve.....	1110
Procedure.....	1110
Grips.....	1112
Loft.....	1112
Procedure.....	1112
Grips.....	1114
Sweep.....	1115
Procedure.....	1115
Grips.....	1117
Slice.....	1118
Procedure.....	1118
Section.....	1120
Procedure.....	1120
Grips.....	1126
Thicken.....	1127
Procedure.....	1127
Presspull.....	1128
Procedure.....	1128
Xedges.....	1130
Procedure.....	1130
Offset edge.....	1131
Procedure.....	1131
Fillet edge.....	1133
Procedure.....	1133
Chamfer edge.....	1134
Procedure.....	1134
Solid editing.....	1135
Procedure.....	1136
<i>Sheet modeling.....</i>	<i>1139</i>
Sheet solid.....	1139
Procedure.....	1139
Dialog.....	1142
3D History.....	1142
Shell.....	1143

Procedure.....	1143
Dialog.....	1145
3D History.....	1146
Ruled shell.....	1146
Procedure.....	1146
Dialog.....	1148
3D History.....	1148
Plate.....	1149
Procedure.....	1149
Dialog.....	1151
3D History.....	1151
Bend along edge.....	1152
Procedure.....	1152
Dialog.....	1156
3D History.....	1158
Bend by sketch.....	1159
Procedure.....	1159
Dialog.....	1163
3D History.....	1163
Bend along line.....	1163
Procedure.....	1164
Dialog.....	1166
3D History.....	1166
Jog.....	1166
Procedure.....	1167
Dialog.....	1169
3D History.....	1169
Closing corners.....	1170
Procedure.....	1170
Dialog.....	1172
3D History.....	1172
Hole.....	1173
Procedure.....	1173
Dialog.....	1176
3D History.....	1176
Unbend.....	1176
Procedure.....	1177
Dialog.....	1180
3D History.....	1180
Bend.....	1180
Procedure.....	1180
3D History.....	1184
Flatten.....	1184
Procedure.....	1184
Dialog.....	1186
3D History.....	1186
Stamp.....	1187
Procedure.....	1187
Dialog.....	1189
3D History.....	1189
Jalousie.....	1190
Procedure.....	1190
Dialog.....	1192
3D History.....	1192
Bead.....	1193
Procedure.....	1193
Dialog.....	1195
3D History.....	1195
Rib.....	1196
Procedure.....	1196
Dialog.....	1199
3D History.....	1199
Flanging.....	1200
Procedure.....	1200
Dialog.....	1202
3D History.....	1202
<i>Editing.....</i>	<i>1203</i>

3D Align.....	1203
Procedure.....	1203
Manipulators .....	1206
Setting up automatic call.....	1206
3D Move .....	1207
Procedure.....	1208
3D Rotate.....	1209
Procedure.....	1210
3D Scale .....	1211
Procedure.....	1212
3D Rectangular Array.....	1214
Procedure.....	1214
3D History.....	1216
3D Polar Array.....	1217
Procedure.....	1217
3D History.....	1220
3D Fillet.....	1220
Procedure.....	1220
3D History.....	1221
3D Chamfer.....	1221
Procedure.....	1222
3D History.....	1224
3D Thread .....	1224
Procedure.....	1225
Edit .....	1226
3D History.....	1227
3D Mirror.....	1227
Procedure.....	1228
3D History.....	1229
Union .....	1230
Procedure.....	1230
3D History.....	1231
Intersect.....	1231
Procedure.....	1231
3D History.....	1232
Subtract .....	1232
Procedure.....	1232
3D History.....	1234
Add work plane.....	1234
Procedure.....	1234
Properties.....	1235
Grips .....	1235
3D History.....	1235
Add work axis.....	1235
Procedure.....	1236
Properties.....	1236
Grips .....	1236
3D History.....	1236
Add work point .....	1237
Procedure.....	1237
Properties.....	1237
Grips .....	1237
3D History.....	1237
<b>3D Constraint .....</b>	<b>1238</b>
Mate 3D Constraint .....	1238
Procedure.....	1238
Edit .....	1239
Insert 3D Constraint.....	1240
Procedure.....	1240
Edit .....	1241
Angle 3D Constraint.....	1242
Procedure.....	1242
Edit .....	1243
Tangent 3D Constraint.....	1244
Procedure.....	1244
Edit .....	1246
Symmetry 3D Constraint.....	1246

Procedure .....	1246
Edit .....	1250
<b>Converts .....</b>	<b>1250</b>
Convert to Mesh .....	1250
Procedure .....	1251
Convert to Solid .....	1251
Procedure .....	1252
<b>2D Views .....</b>	<b>1253</b>
Section Plane .....	1253
Procedure .....	1253
Properties .....	1258
Grips .....	1261
3D History .....	1261
2D View .....	1261
Procedure .....	1262
Edit .....	1263
Properties .....	1263
Grips .....	1264
3D History .....	1264
2D Projection .....	1264
Procedure .....	1264
2D Section .....	1265
Procedure .....	1266
Hatching Sections .....	1267
Procedure .....	1267
2D CONSTRAINTS .....	1268
2D CONSTRAINTS .....	1268
<i>Geometric constraints</i> .....	1268
Procedure .....	1269
Coincident .....	1269
Procedure .....	1269
Allowable objects and dependency points .....	1270
Collinear .....	1271
Procedure .....	1271
Allowable objects and dependency points .....	1272
Vertical .....	1272
Procedure .....	1272
Allowable objects and dependency points .....	1273
Horizontal .....	1273
Procedure .....	1273
Allowable objects and dependency points .....	1274
Perpendicular .....	1274
Procedure .....	1274
Allowable objects and dependency points .....	1275
Parallel .....	1275
Procedure .....	1276
Allowable objects and dependency points .....	1276
Tangent .....	1277
Procedure .....	1277
Allowable objects and dependency points .....	1278
Smooth .....	1278
Procedure .....	1278
Allowable objects and dependency points .....	1279
Concentric .....	1279
Procedure .....	1280
Allowable objects and dependency points .....	1281
Equal .....	1281
Procedure .....	1281
Allowable objects and dependency points .....	1282
Symmetric .....	1282
Procedure .....	1282
Allowable objects and dependency points .....	1284
Fix .....	1284
Procedure .....	1284
Allowable objects and dependency points .....	1285
<i>Parametric dimensions</i> .....	1285

Aligned .....	1285
Procedure .....	1285
Edit .....	1287
Allowable objects and dependency points .....	1287
Linear .....	1287
Procedure .....	1287
Edit .....	1289
Allowable objects and dependency points .....	1289
Horizontal .....	1289
Procedure .....	1289
Edit .....	1291
Allowable objects and dependency points .....	1291
Vertical .....	1291
Procedure .....	1291
Edit .....	1293
Allowable objects and dependency points .....	1293
Radial .....	1293
Procedure .....	1293
Edit .....	1294
Allowable objects and dependency points .....	1294
Diameter .....	1294
Procedure .....	1295
Edit .....	1296
Allowable objects and dependency points .....	1296
Angular .....	1296
Procedure .....	1296
Edit .....	1297
Allowable objects and dependency points .....	1298
Dimensional constraint .....	1298
Procedure .....	1298
<i>Parameters Manager</i> .....	1299
Procedure .....	1299
Using Dimensional Constraints .....	1301
Operators and functions .....	1303
Operators .....	1303
Functions .....	1304
<i>Auto constrain</i> .....	1305
Procedure .....	1305
<i>Constraint settings</i> .....	1306
Procedure .....	1306
<i>Show/hide constraints</i> .....	1308
Procedure .....	1308
<i>Delete constraints</i> .....	1308
Procedure .....	1308
LIGHT SOURCES .....	1309
<i>Point Light</i> .....	1309
<i>Spotlight</i> .....	1311
<i>Distant Light</i> .....	1313
<i>Weblight</i> .....	1314
COVERINGS .....	1315
<i>Coverings Browser</i> .....	1316
Coverings Library .....	1318
<i>Coverings Editor</i> .....	1319
<i>Texture Editor</i> .....	1321
<b>TOOL PALETTES</b> .....	<b>1324</b>
CREATE A TOOL PALETTE .....	1325
CREATE A TOOL PALETTE GROUP .....	1326
CREATE A TOOL .....	1326
EXECUTE THE TOOL .....	1329
DELETE THE TOOL .....	1330
EDIT THE TOOL .....	1330
EXPORT TOOL PALETTE .....	1330
IMPORT TOOL PALETTE .....	1330

<b>POINT CLOUDS .....</b>	<b>1332</b>
IMPORT OF POINT CLOUDS .....	1332
<i>Import from Text Formats .....</i>	<i>1333</i>
<i>Point Clouds Import Dialog Box.....</i>	<i>1334</i>
EXPORT OF POINT CLOUDS .....	1346
WORK WITH DBMS-BASED POINT CLOUD STORAGE .....	1347
<i>Importing Cloud Data from DBMS.....</i>	<i>1348</i>
<i>Exporting Cloud Data to DBMS .....</i>	<i>1349</i>
<i>Configuring Connections to the DBMS .....</i>	<i>1350</i>
<i>Managing Point Cloud Revisions in the DBMS .....</i>	<i>1353</i>
POINT CLOUDS DATA FORMATS.....	1353
<i>Supported Formats of Point Cloud Files .....</i>	<i>1353</i>
LAS .....	1353
LAZ .....	1354
BIN (Terrasolid format) .....	1354
PTX (Leica Cyclone Format) .....	1355
E57 .....	1355
PTS .....	1356
PCD .....	1356
TXT .....	1357
XYZ .....	1357
XYB (Faro) .....	1357
PLY .....	1357
NPC (nanoCAD Point Cloud Storage Format).....	1357
RCS (ReCap Format).....	1358
RCP (Autodesk Native Format) .....	1358
EXTRACT FROM VIEW .....	1358
CREATE A NEW CLOUD BASED ON CLIPPING.....	1359
POINT CLOUDS COORDINATES TRANSFORMATION .....	1359
<i>Transformation to Default Coordinates .....</i>	<i>1359</i>
<i>Recalculation of Point Cloud Coordinates by EPSG .....</i>	<i>1360</i>
POINT CLOUDS DISPLAY SETTINGS.....	1361
<i>Display Settings .....</i>	<i>1361</i>
<i>Point Cloud Display Style .....</i>	<i>1363</i>
Scan Color .....	1365
Elevation .....	1366
Intensity.....	1367
Code.....	1368
Echo number .....	1369
Color .....	1370
Source ID.....	1371
Normal .....	1372
Deviation value .....	1373
Feature and Feature type .....	1374
<i>Hiding the Point Cloud.....</i>	<i>1375</i>
<i>Displaying a Point Cloud.....</i>	<i>1376</i>
<i>Clip Point Clouds.....</i>	<i>1376</i>
Clip Point Clouds by 2 Points of Rectangle .....	1377
Clip Point Clouds by 3 Points of Rectangle .....	1378
Clip Point Clouds by Fence.....	1378
Clipping Clouds by Sphere .....	1379
Clipping Clouds by Cylinder .....	1380
Clip Undo .....	1381
Reset All Clips.....	1381
<i>Point Clouds Section .....</i>	<i>1381</i>
Point Clouds Unrestricted Section .....	1382
Point Cloud Horizontal Section .....	1382
Point Cloud Vertical Section .....	1383
<i>Clip Invert .....</i>	<i>1383</i>
<i>Copying a Clip to the Selected View .....</i>	<i>1383</i>
<i>Isolate Features.....</i>	<i>1384</i>
Hiding a Feature .....	1385
Hiding All Features.....	1387

Isolating a Feature .....	1387
Isolating All Features .....	1389
Showing All Features .....	1390
Feature Isolation Reset.....	1391
INFORMATION .....	1392
<i>Point Cloud Comparison Widget</i> .....	1392
Enabling the Point Cloud Comparison Widget.....	1392
Disabling the Point Cloud Comparison Widget.....	1393
<i>Point Cloud Info</i> .....	1393
Statistics.....	1393
Cloud Attributes.....	1395
Geoinformation .....	1398
<i>Point Info</i> .....	1399
<i>Determining the Radius</i> .....	1400
<i>Determining the Diameter</i> .....	1401
<b>TOPOPLAN MODULE.....</b>	<b>1402</b>
NEW TOPOPLAN .....	1403
RECALCULATION OF COORDINATES BY EPSG CODES .....	1405
CREATING GEOPOINTS .....	1406
<i>Geopoint Object</i> .....	1406
Geopoints in the Drawing Explorer.....	1408
Marker and Label Styles of Geopoints.....	1409
Geopoint Groups .....	1410
User-Defined Properties of Geopoints .....	1411
<i>Ceopoints Manually</i> .....	1413
<i>Creating Geopoints by Points and Texts</i> .....	1414
<i>Creating Geopoints by Interpolation</i> .....	1416
<i>Creating Geopoints by Surface</i> .....	1416
<i>Point Conversion</i> .....	1417
<i>Creating a Group of Geopoints Manually</i> .....	1425
<i>Creating Groups of Geopoints by Original Description</i> .....	1426
<i>Creating Label Styles of Geopoints</i> .....	1426
<i>Creating Marker Styles of Geopoints</i> .....	1427
<i>Editing Label Styles of Geopoints</i> .....	1427
<i>Editing Label Properties of Geopoints</i> .....	1428
<i>Editing Marker Styles of Geopoints</i> .....	1429
<i>Editing Properties of Geopoint Groups</i> .....	1430
<i>Description Key Sets and Description Keys</i> .....	1430
Description Key Sets .....	1430
Creating a Description Key Set .....	1430
Deleting a Description Key Set .....	1431
Modifying a Description Key Set.....	1431
Description Keys .....	1432
Code of a Description Key .....	1432
Creating a description key.....	1433
Deleting a description key .....	1434
Modifying a Description Key.....	1434
CREATING SURFACES.....	1435
<i>Exploding a Cloud into Points</i> .....	1435
<i>Create TIN by Points</i> .....	1438
<i>Importing Elevation Grid</i> .....	1441
<i>Converting to Meshes or 3D Faces</i> .....	1442
<i>Converting Model to 3D Faces</i> .....	1443
<i>Converting Model to SubMesh</i> .....	1443
<i>Converting Model to Polyface Mesh</i> .....	1444
TOOLS TO WORK WITH SURFACES .....	1445
<i>Simplifying the Mesh</i> .....	1445
<i>Adding an Edge</i> .....	1447
<i>Flip Edge</i> .....	1448
<i>Deleting an Edge</i> .....	1449
<i>Adding a Vertex</i> .....	1450

<i>Deleting a Vertex</i> .....	1451
<i>Changing Elevation</i> .....	1452
<i>Moving a Point</i> .....	1453
<i>Adding Structure Line</i> .....	1454
<i>Mesh Sealing Holes</i> .....	1457
<i>Mesh Boundary</i> .....	1458
<i>Cutting Mesh</i> .....	1460
<i>Classification Mesh</i> .....	1461
<i>Adding a group of Points</i> .....	1462
TOOLS TO WORK WITH RELIEF ELEMENTS .....	1463
<i>Constructing Contours</i> .....	1463
<i>Creating Bergstriches</i> .....	1464
<i>Creating Contour Lines Labels</i> .....	1465
<i>2D Slope</i> .....	1466
<i>3D-Slope</i> .....	1469
<i>Offset of a 3D-Polyline</i> .....	1473
<i>Deleting Contour Lines</i> .....	1474
<i>Building a Profile Line</i> .....	1474
<i>Search for Key Lines on the Surface</i> .....	1475
<i>Projecting a Line onto a Mesh</i> .....	1478
<i>Correction of Zero Elevation</i> .....	1479
<i>Projecting Objects onto a Surface</i> .....	1480
<i>Managing Block Marker Attributes</i> .....	1481
TEXTURING AND CALCULATION .....	1481
<i>Flat Texture Overlay</i> .....	1481
<i>Raster Texture Mapping</i> .....	1483
<i>Mesh Coloring by Height</i> .....	1484
<i>Calculating Volumes between Models</i> .....	1487
<i>Calculating Surface Volume</i> .....	1488
<i>Calculating Area</i> .....	1489
<i>Surface Difference</i> .....	1490
<i>Forming a Legend</i> .....	1490
DRAWING CONTEXT .....	1491
<i>Conventional Signs</i> .....	1491
<i>Creating Customized Library of Conventional Signs</i> .....	1493
Structure of a Library of Conventional Signs.....	1493
Creating a Customized Library Using Teplate.....	1494
Adding Conventional Signs to the Library.....	1494
Adding point signs (blocks).....	1494
Adding line signs (polylines and multilines).....	1495
Editing the Existing Conventional Signs of the Library.....	1496
<i>Topographic Hatches</i> .....	1497
<i>Importing Geo-linked Rasters</i> .....	1504
IMPORT AND EXPORT.....	1504
<i>Importing Geopoints</i> .....	1504
<i>Exporting Geopoints</i> .....	1514
<i>Import from LandXML</i> .....	1520
<i>Export to LandXML</i> .....	1521
<i>Import from GIS</i> .....	1521
<i>Export to GIS</i> .....	1526
<i>Import of KML/KMZ files</i> .....	1535
DESIGN OF LAYOUTS .....	1536
<i>Creating Frames</i> .....	1536
<i>Creating Layouts by Frames</i> .....	1540
<i>Hiding Frames</i> .....	1542
<i>Deleting Frames</i> .....	1543
MEASUREMENT ARCHIVE .....	1543
<i>Adding Measurement File</i> .....	1544
<i>Import Measurements</i> .....	1545
<i>Save to Measurement Archive</i> .....	1545
<i>Attach Geounderlay</i> .....	1546



<i>Save as Geounderlay</i> .....	1547
<b>THE COMPONENT LAYOUT AND PLOT DRAWING</b> .....	<b>1548</b>
MODEL SPACE AND PAPER SPACE .....	1548
WORK WITH LAYOUTS .....	1551
<i>To Create a New Layout</i> .....	1551
<i>To Create a Layout from a Template</i> .....	1552
Copy Layout .....	1553
Copy Layout without Viewport .....	1554
<i>Save a Layout as a Template</i> .....	1554
<i>Delete Layout</i> .....	1555
<i>Rename Layout</i> .....	1556
<i>Layouts Manager</i> .....	1556
<i>Managing Layouts from the Command Line</i> .....	1558
EXPORT LAYOUT TO MODEL .....	1559
VIEWPORTS .....	1559
<i>Create Layout Viewports</i> .....	1560
Create a Rectangular Viewport .....	1560
Create a rectangular viewport from the model space .....	1560
Create a rectangular viewport from a layout .....	1560
Create a Polygonal Viewport .....	1561
Create a polygonal viewport from the model space .....	1561
Create a polygonal viewport from a layout .....	1562
Create a Viewport by Object .....	1562
Create a viewport by object from the model space .....	1562
Create a viewport by object from a layout .....	1563
<i>Edit Layout Viewports</i> .....	1563
Aligning Viewport Objects .....	1565
Set Show Boundary for a Viewport .....	1566
<i>Change Space</i> .....	1567
DOCUMENT PLOT .....	1568
<i>Page Setup Manager</i> .....	1569
Page Setup .....	1572
Saving Plotter Settings to PC3 File .....	1578
<i>Paper Formats</i> .....	1579
Modifying and Adding the Paper Formats .....	1579
Editing the List of Paper Formats .....	1581
<i>Plot Preview</i> .....	1583
<i>Plot Style Manager</i> .....	1586
<i>Plot</i> .....	1588
<i>Batch Plot</i> .....	1592
Features of the Batch Plot from the Model Space .....	1598
<i>Internal PDF-Plotter</i> .....	1599
<b>EDS</b> .....	<b>1603</b>
CREATING INTERNAL EDS .....	1603
CREATING EXTERNAL EDS FILE .....	1604
<b>SHEET SET</b> .....	<b>1606</b>
CREATE SHEET SET .....	1606
OPEN SHEET SET .....	1612
SHEET SET MANAGER FUNCTIONAL BAR .....	1612
<i>Set of Layouts</i> .....	1613
<i>Set of Views</i> .....	1614
<i>Mixed Type Set</i> .....	1615
<i>Interface of the Sheet Set Manager</i> .....	1615
<i>Sheet Set Tree Elements</i> .....	1616
SHEET SET PROPERTIES .....	1617
<i>Sheet Set Custom Properties</i> .....	1619
BLOCKS IN THE SHEET SETS .....	1621
<i>Label Block for Views</i> .....	1621
<i>Callout Blocks</i> .....	1622

ACTIONS ON SHEET SET AND ITS ELEMENTS .....	1622
<b>COMMAND SCRIPTS AND EXTENSIONS .....</b>	<b>1628</b>
COMMAND SCRIPTS (SCR) .....	1628
SOFTWARE EXTENSIONS .....	1628
<i>NRX and LISP File Loading</i> .....	1629
<i>.NET Application Loading</i> .....	1630
<i>JScript Loading</i> .....	1630
<i>VBScript Loading</i> .....	1630
<i>NSF Files Loading</i> .....	1630
<i>Work with LISP-Applications</i> .....	1631
<i>The ncad.lsp file</i> .....	1631
SCRIPT EDITOR (JS, VBS, LSP, DCL, SCR) .....	1632
<i>Options</i> .....	1633
<i>Find and Replace in Scripts</i> .....	1636
Find and Replace Bar .....	1636
Regular Expressions.....	1637
Bookmarks .....	1638
Move to a Line by Number .....	1639
Shortcuts.....	1639
CREATING COMMANDS FROM DOWNLOADABLE APPLICATIONS AND COMMAND SCRIPTS .....	1641
RUN NANO CAD FROM COMMAND LINE WITH PROGRAM MODULE .....	1642
<b>INDEX.....</b>	<b>1644</b>

## TRADEMARKS

---

No section of the documentation may be changed, adapted or translated into other languages without the prior written permission of Nanosoft Razrabotka. It is not permitted to create derivative documents based on materials in this publication.

ActiveX, Direct3D, Excel, Access, Internet Explorer, JScript, Microsoft, MS-DOS, OpenType, Outlook, Visual Basic, Visual C++, Visual C#, Visual Studio, Windows, Windows Server, Windows Vista are trademarks or registered trademarks of Microsoft, Inc.

Adobe, Acrobat, Acrobat Reader – are trademarks or registered trademarks of Adobe Systems Incorporated.

AMD, AMD Athlon, AMD Duron, AMD Opteron, AMD-K6 – are trademarks of Advanced Micro Devices, Inc.

Autodesk, AutoCAD are registered trademarks of Autodesk, Inc.

DWG is the native file format for Autodesk's AutoCAD® software.

Intel, MMX, Celeron, Core, i386, i486, Pentium, Xeon, Atom – are trademarks or registered trademarks of Intel Corporation.

nanoCAD © 2024 Nanosoft AS.

CADECS SDK © 2019 CSoft Development.

Teigha™ for .dwg files 2019 by Open Design Alliance. All rights reserved.

C3D Toolkit © C3D Labs. All rights reserved.

ANTLR 3 License [The BSD License] © 2010 Terence Parr. All rights reserved.

Cef3 (Chromium Embedded Framework) © 2008-2014 Marshall A. Greenblatt. Portions © 2006-2009 Google Inc. All rights reserved.

Boehm-Demers-Weiser Garbage Collector © 1988, 1989 Hans-J. Boehm, Alan J. Demers, ..., 1999-2011 by Hewlett-Packard Development Company (<http://www.hboehm.info/gc/license.txt>)

The OpenGL Extension Wrangler Library Copyright © 2002-2007, Milan Ikits <[milan\\_ikits@ieee.org](mailto:milan_ikits@ieee.org)> © 2002-2007, Marcelo E. Magallon <[mmagallo@debian.org](mailto:mmagallo@debian.org)> © 2002, Lev Povalahev

jbig2dec © Artifex Software, Inc. 2002-2005.

WpfToolkit © Xceed Software, Inc.

The Qt Toolkit is Copyright © 2017 The Qt Company Ltd. and other contributors. Licensed under the terms of the GNU Lesser General Public License version 3.

Qt Solutions Copyright © 2013 Digia Plc and/or its subsidiary(-ies). Licensed under the terms of the BSD license.

msdfgen Copyright © 2016 Viktor Chlumsky (<https://github.com/Chlumsky/msdfgen/>).

Microsoft UVAtlas Copyright © Microsoft Corporation.  
(<http://go.microsoft.com/fwlink/?LinkID=512686>).

boost (<https://www.boost.org/users/license.html>).

Eigen C++ template library (<https://eigen.tuxfamily.org/index.php>).

nanoflann Copyright © 2011-2020 Jose Luis Blanco-Claraco  
(<https://github.com/jlblancoc/nanoflann>).

ChartControl Copyright © 2006-2010 Cedric Moonen  
(<https://www.codeproject.com/Articles/14075/High-speed-Charting-Control>).

Xerces-C++ XML parser Copyright © 1999-2017 The Apache Software Foundation.  
(<http://xerces.apache.org/xerces-c/> SPDX-License-Identifier: Apache-2.0).

CMake project libe57 Copyright 2010 Roland Schwarz (rschwarz@riegl.co.at), Riegl LMS GmbH, All Rights Reserved. (<http://libe57.org/>).

APNG Assembler Copyright © 2010-2016 Max Stepin maxst@users.sourceforge.net (<http://apngasm.sourceforge.net/>).

Portions Copyright (c) 2015-2021, Postgres Professional

Portions Copyright (c) 1996-2021, PostgreSQL Global Development Group

Portions Copyright (c) 1994 Regents of the University of California  
<https://postgrespro.ru/products/postgrespro/eula> (c) Copyright 2021 xbim  
ltd.(<https://docs.xbim.net/license/license.html>)

Scintilla Copyright 1998-2003 by Neil Hodgson neilh@scintilla.org

All other names may be trademarks or registered trademarks of their respective owners. The software complex of nanoCAD described in this manual is distributed in accordance with the terms set forth in the License Agreement and cannot be used, transferred or sold on any other terms other than those expressly stipulated in this agreement.

# GENERAL INFORMATION

---

## *Introduction*

nanoCAD is a professional grade CAD tool. It has a familiar interface, powerful drafting and design tools, native DWG compatibility, and an open API. nanoCAD has been built to deliver design and project documentation for all industries. nanoCAD includes a full suite of basic and advanced tools, for creating industry-standard DWG-compatible CAD files. nanoCAD provides innovative, collaborative and customizable features to enhance your efficiency. nanoCAD includes several API's, allowing anything from routine task automation to complex CAD application development.

nanoCAD implements a very efficient, and easy to learn, classic-style CAD user interface. It offers a command set and UI elements appearance that will be familiar and comfortable to users of many other compatible CAD applications. The drawing space, command line, and position of the menu items and icons on the toolbars are readily recognizable. Any person with AutoCAD experience will feel at home using nanoCAD, right from the start.

nanoCAD uses the industry-standard DWG (\*.dwg) file format natively. Drawings created or edited in nanoCAD can be used by almost any other popular CAD system, without conversion or data loss. If you can't open a drawing from another system due to damage, or you want to audit an opened drawing for errors, or you need to reduce file size, nanoCAD provides Audit, Recover and Purge commands. Be assured you will not lose document data due to software or hardware failures thanks to nanoCAD's autosaving and backup functions.

nanoCAD includes an extensive set of tools for creating and editing 2D/3D objects. There are often multiple drawing methods available for creating most of geometric elements. It's well-thought-out object editing commands allow you to modify drawings with minimal mouse clicks. Reusable blocks and references to external drawings simplify and speed up the drawing process. Advanced dimensioning features enable you to create any kind of dimensions by several means.

nanoCAD has a powerful Excel-style table editor, with an extensive set of capabilities, including the ability to create tables containing cells with embedded macros and formulas.

Tool Palettes allow you quickly and easily use your favorite commands and blocks. Organizations that use their own set of blocks, hatches and scripts can now load and use them in one click.

You can import point clouds in drawing in five formats: Bin (TerraSolid), LAS (ASPRS), PTX (Leica), PTS (Leica) and PCD (Point Cloud). Powerful import dialog allows you to import only the required parts of clouds. You can create and modify sections and clips of loaded clouds, tune visualization parameters.

The nanoCAD scripting engine allows average users to automate everyday routine tasks. Users can write macros using Visual Basic Script, Java Script or any other scripting language supported by Microsoft Windows as well as built-in LISP.

nanoCAD has several types of APIs for building CAD applications on top of its core functionality. NRX is a C++ and .NET API very similar to AutoCAD's ARX. It allows the translation of AutoCAD-based applications to nanoCAD with ease. It is an object-oriented, compact and robust programming interface. It is field proven, and has been used to create a large number of commercial CAD applications.

nanoCAD also features the MultiCAD API™ for C++ and .NET, a revolutionary development tool to create binary compatible applications for different CAD platforms. Applications developed with the MultiCAD API will be able to run not just in nanoCAD, but also in other compatible CAD systems—including AutoCAD.

nanoCAD's plot settings dialog allow you to set multiple plot areas, and create multi-page plots. This can be especially useful for printing large drawings on printers with smaller output format. The Batch Plot command creates and prints drawing sets without requiring you to babysit the process. It is convenient when you need to print existing projects. It also supports outputting drawings to single or multi-sheet plot files.

## Modular Program Configuration

In addition to the main functionality, nanoCAD includes several independently licensed built-in modules:

- The **Construction** module. The module allows you to quickly and accurately draw up design documentation in accordance with the general technical requirements of regulatory documents used in the construction industry. Plans, elevations, cuts, sections, views, units and other drawings are made "on-the-fly" using tools that create dynamic "smart" drawings.
- The **Mechanica** module. The module is intended for the design of engineering products and execution of design and technological documentation in full compliance with the requirements of major international standards. The availability of parametric objects and middle-level computer-aided design tools make this software solution one of the most convenient tools for creating and designing drawings.
- The **Raster** module expands the capabilities of the work with various raster images, including scanned documents – drawings, plans, diagrams, etc. Basic configuration of nanoCAD provides the possibility to use such kind of data only as an underlay, accompanying it with a set of several tools for 4-point correction, alignment, cropping and setting the parameters for displaying raster images. The **Raster Editing** module includes a wide range of tools for improving the quality of images, their transformation, intellectual analysis and editing, extracting semantic information (vectorization), semi-automatic tracing of vector entities and text recognition, as well as rasterization of an arbitrary type of data supported by nanoCAD.
- The **3D** module on the **C3D** core, which includes the functionality of **2D and 3D Constraints**. The module allows using 3D design tools to form complex 3D scenes of any geometric shape. Using the section function, you can get automatically updated 2D views.
- The **Topoplan** module is designed to create a digital terrain model and prepare a drawing for the release of topographic plans. The module includes support for Civil 3D objects. If you open a drawing containing such objects, they will be displayed as drawing objects (and not as proxy graphics), their properties will be displayed, styles can be switched, and style elements can be controlled.

During the trial period, all modules are available. At the end of the trial period, to activate any module, you should obtain the appropriate license.

### Installation of external applications

In addition, external applications designed for a specific version can simply be installed additionally to the already used nanoCAD.

## System Requirements

<b>Operating system</b>	Microsoft® Windows® 8.1 (64-bit); Microsoft Windows 10 (64-bit); Microsoft Windows 11. <b>Note:</b> It is recommended to use 64-bit operating systems, when working with large data sets, point clouds and 3D modeling.
<b>Databases</b>	To work with databases for point clouds it is necessary to install PostGis extension for PostgreSQL.

<b>Processor</b>	<b>Minimum requirements:</b> 2 GHz. <b>Recommended:</b> 3 GHz or higher.										
<b>RAM</b>	<b>Minimum requirements:</b> 4 GB. To work with point clouds – 16 GB. <b>Recommended:</b> 16 GB and more. To work with point clouds – 32 GB and higher										
<b>Monitor</b>	<b>Minimum required resolution:</b> 1920 x 1080. <b>High resolution monitors:</b> 3840 x 2160 (supported in Windows 10, 11).										
<b>Graphics</b>	<b>Minimum requirements:</b> graphics processor with 1 GB video memory. <b>Recommended:</b> graphics processor with 4 GB video memory (supports OpenGL 2.1 or DirectX 11).										
<b>Hard disk free space</b>	<p>7,0 GB and more (for program installation). To work with large point clouds, it is necessary to take into account their volume and quantity when choosing a hard disk. Estimation of the amount of point cloud data can be carried out according to the following table:</p> <table border="1"> <thead> <tr> <th>Volume of points in a cloud</th> <th>Size in megabytes per HDD</th> </tr> </thead> <tbody> <tr> <td>1 mln.</td> <td>16.02</td> </tr> <tr> <td>100 mln.</td> <td>1611.56</td> </tr> <tr> <td>1 bln.</td> <td>16313.00</td> </tr> <tr> <td>2.5 bln.</td> <td>40782.50</td> </tr> </tbody> </table> <p>It is recommended to store point clouds on SSD disks to speed up the work.</p>	Volume of points in a cloud	Size in megabytes per HDD	1 mln.	16.02	100 mln.	1611.56	1 bln.	16313.00	2.5 bln.	40782.50
Volume of points in a cloud	Size in megabytes per HDD										
1 mln.	16.02										
100 mln.	1611.56										
1 bln.	16313.00										
2.5 bln.	40782.50										
<b>Network</b>	TCP/IP protocol should be run on the license server and all work stations where the applications using network licensing will work.										

## Program Installation

You must have administrator rights to install the program and to launch it for the first time.

You do not need to be an administrator to work with the program; it can be launched by a user with reduced authority.

## Program Registration

The registration process is used to assign a serial number for your copy of the software. This serial number is used to generate a license file, and activate the software.

If the software can be used without registration or activation, it will run in Demo mode, and may only be used for educational or training purposes. You must register and activate the software to use it for commercial, professional, or other for-profit purposes.

If you originally downloaded the software from [www.nanocad.com](http://www.nanocad.com), you will already be registered, and will have been sent your serial number by email. (You may also find your serial number under "My Account", at [www.nanocad.com](http://www.nanocad.com)).

If you have not registered, and do not yet have a serial number, run the Registration Wizard and follow the instructions to get one. You may run the Registration Wizard when installing the software, when starting the software, or by launching it from the Windows **Start > All Programs > Nanosoft AS > nanoCAD en 24.0** folder.

After you have received your serial number, run the Registration Wizard again, and follow the instructions for activation.

The registration and activation processes are described in the Installation Guide, available at [www.nanocad.com](http://www.nanocad.com).

## Launch of nanoCAD

### To launch the program:

- Double click nanoCAD shortcut on the Windows desktop

or

- On the taskbar select **Start > All Programs > Nanosoft AS > nanoCAD en 24.0 > nanoCAD en 24.0**

On the first start after installation, if any previous versions were installed, nanoCAD will prompts to copy settings from these versions. In **Migration of settings** dialog all available profiles will be shows:

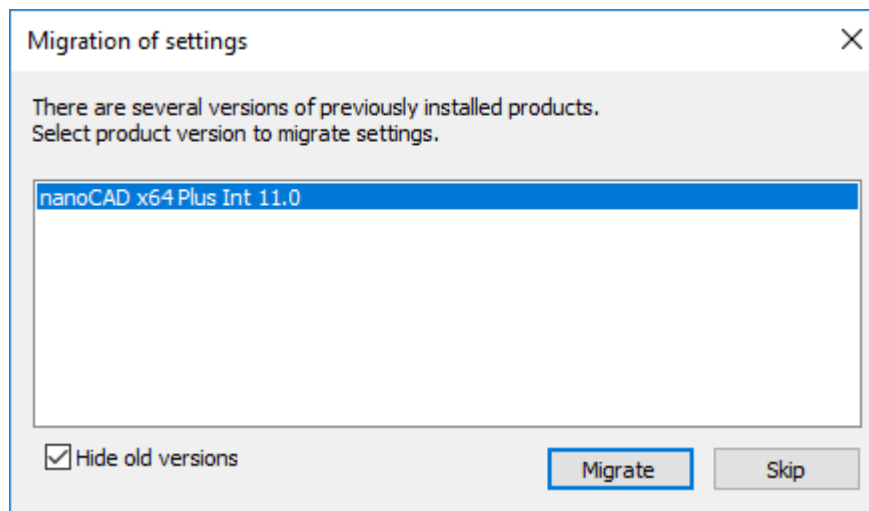

Select desired profile or click **Skip** to skip migration.

For more detailed information see "[Migration of settings from previous versions](#)" section.

## Help System



Program window – **?** **Help**



Menu: **Help** – **?** **About...**



Toolbar: **Main** – **?**



Command line: **HELP, HELPCONTENTS**

**NOTE:** To get help from dialog boxes, use the corresponding buttons. To open context-sensitive help for the active command, press **F1**.

Online help with the updated description of the program functionality is also available at: [https://online-help.nanocad.com/NC24\\_Help](https://online-help.nanocad.com/NC24_Help)



The **License agreement** command shows the license agreement of using nanoCAD in PDF file format.

The **About** command opens the **About nanoCAD 24.0** dialog with information about the version and build of the installed program and copyright.

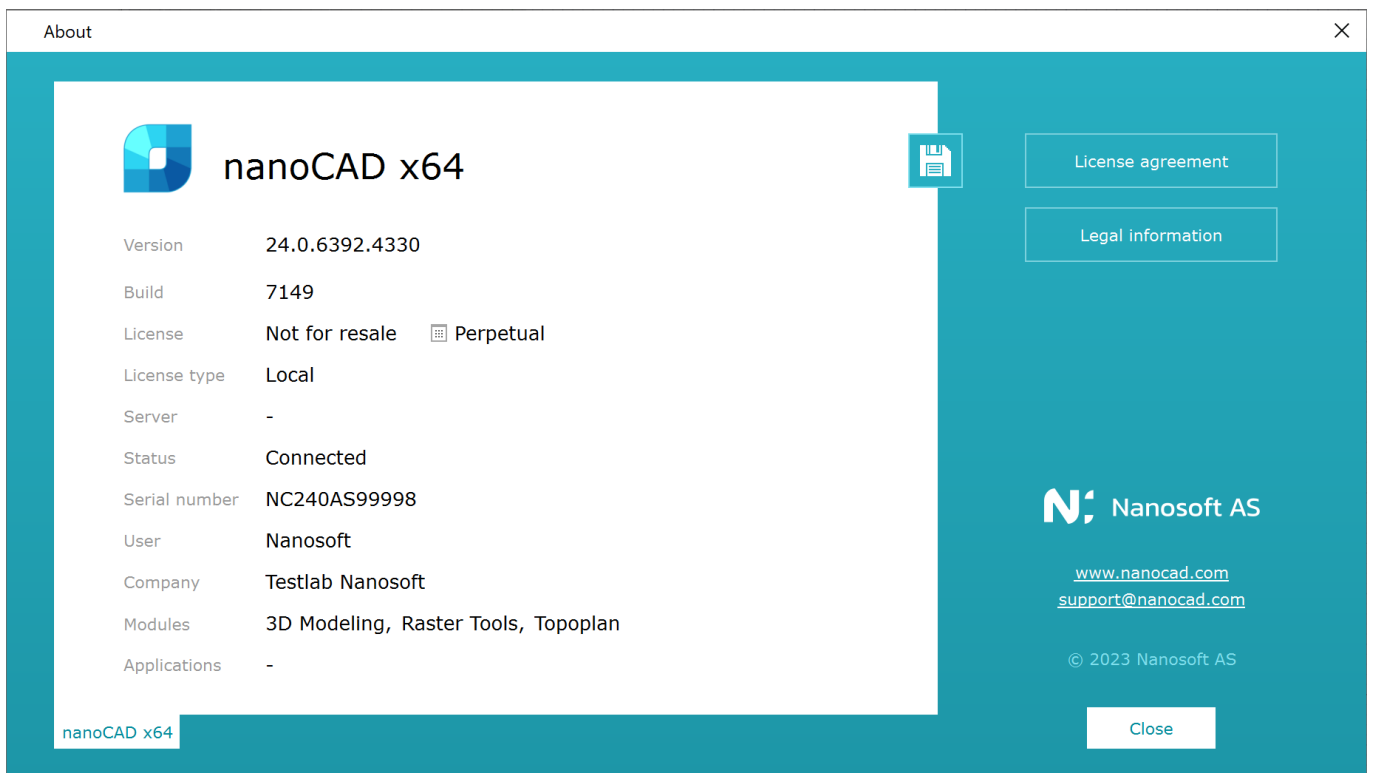

The **About** dialog box shows the license number, who registered the program, a link to the developer’s website – [www.nanocad.com](http://www.nanocad.com) and an email link for support – [support@nanocad.com](mailto:support@nanocad.com)

If you have an internet connection, you can load the links from nanoCAD.

Clicking on the arrow button on the right side of the program window title also provides access to this information data.





## Exit from nanoCAD

 **nanoCAD button**  -  **Exit**

 **Menu: File** -  **Exit**

 **Hotkeys:** **CTRL+Q**

 **Command line:** **EXIT, QUIT**

Just like any Windows application, nanoCAD can be closed by clicking on the  icon in the top right corner of the program.

If all changes in opened documents were saved, no additional messages are shown.

If changes were not saved, nanoCAD shows a warning message:

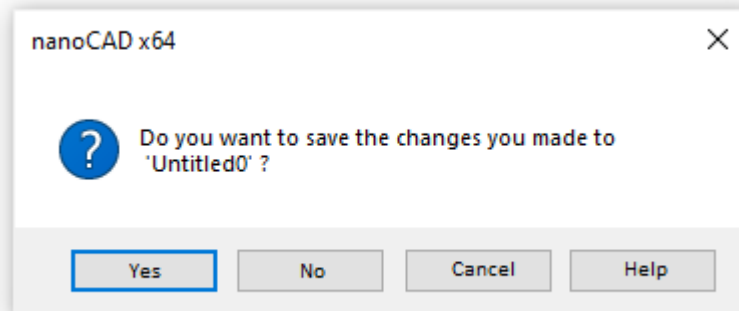

where a user can save changes, decline to save changes or select the **Cancel** button and continue to work in the program.

# NANOCAD USER INTERFACE

**NOTE:** Help with the updated description of the program functionality is available online: <https://nanocad.com/learning/online-help/>.

With nanoCAD you can organize user workspace according to the user's needs and tasks. The standard set of tools is usually used:

*Ribbon interface:*

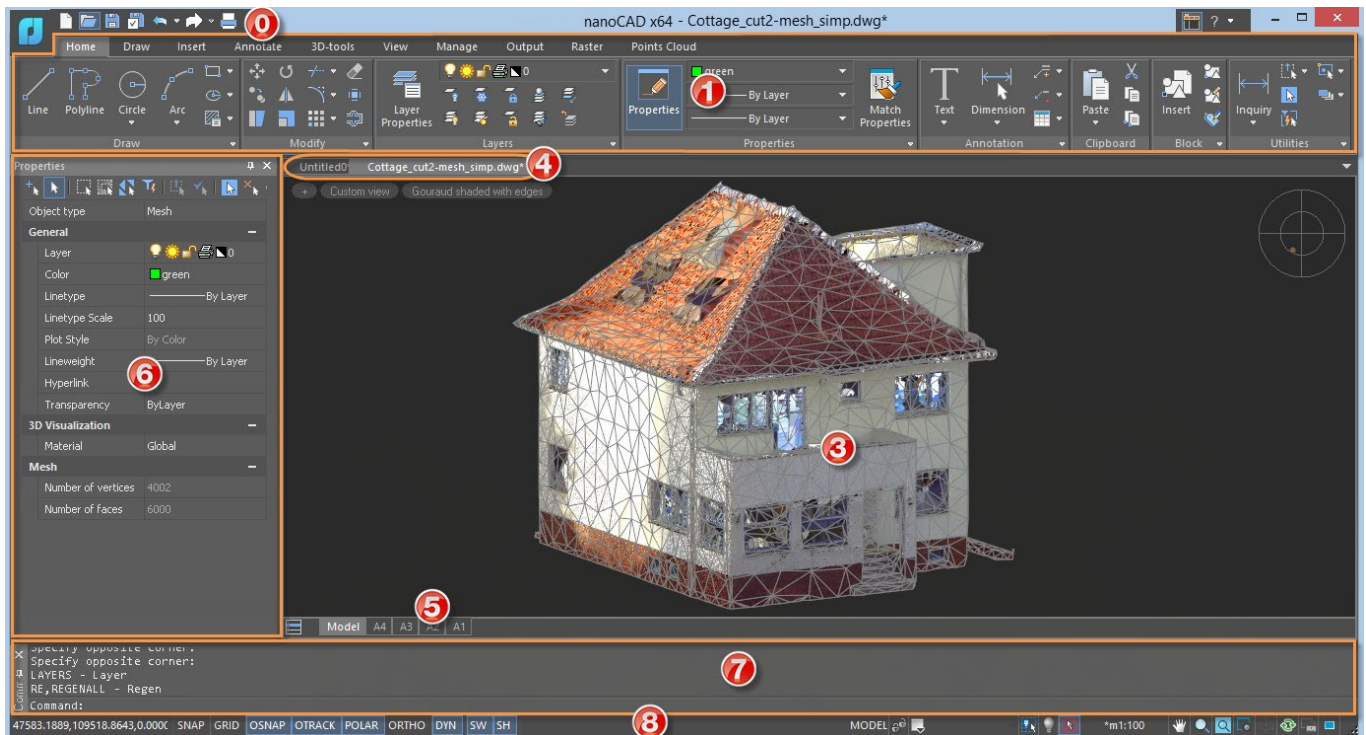

Classic interface (with main menu and toolbars instead of ribbon):

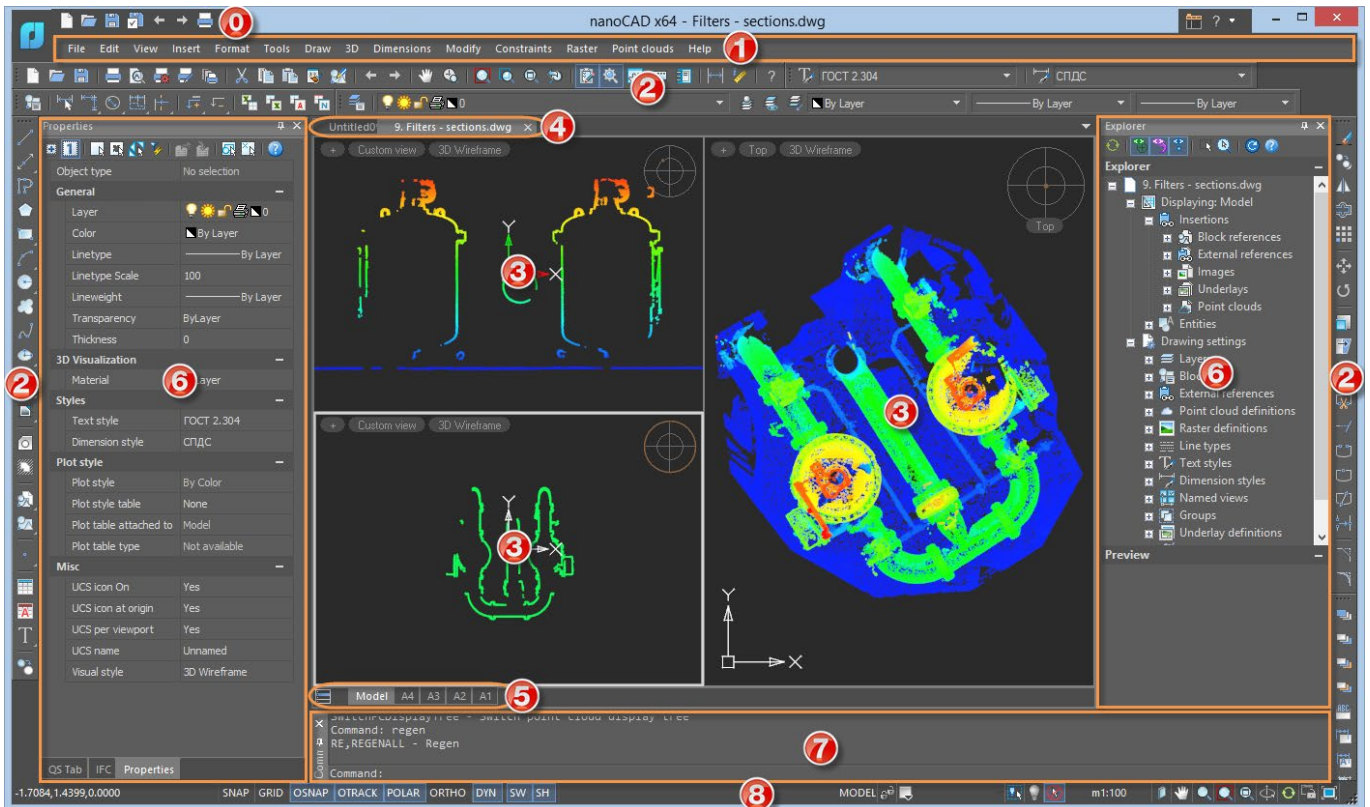

The nanoCAD workspace consists of the following interface elements:

- the [nanoCAD button](#) and the [Quick Access toolbar](#) (0);
- [ribbon](#) or [main menu](#) (1);
- [toolbars](#) (2);
- [drawing window](#) (drawing area) (3);
- documents' tabs (4);
- document layouts' tabs (5);
- [Properties](#) bar (6);
- [command line](#) (7);
- [status bar](#) (8).

Most interface elements can be moved to other places; they can be *fixed* or *floating*. Some elements can be *auto hidden*.

## The nanoCAD Button

By clicking the *nanoCAD button*  with the program logo, you can access the file management, printing, and document utility commands: audit, restore, recover, purge etc. The list of recently used files and folders is also displayed here.

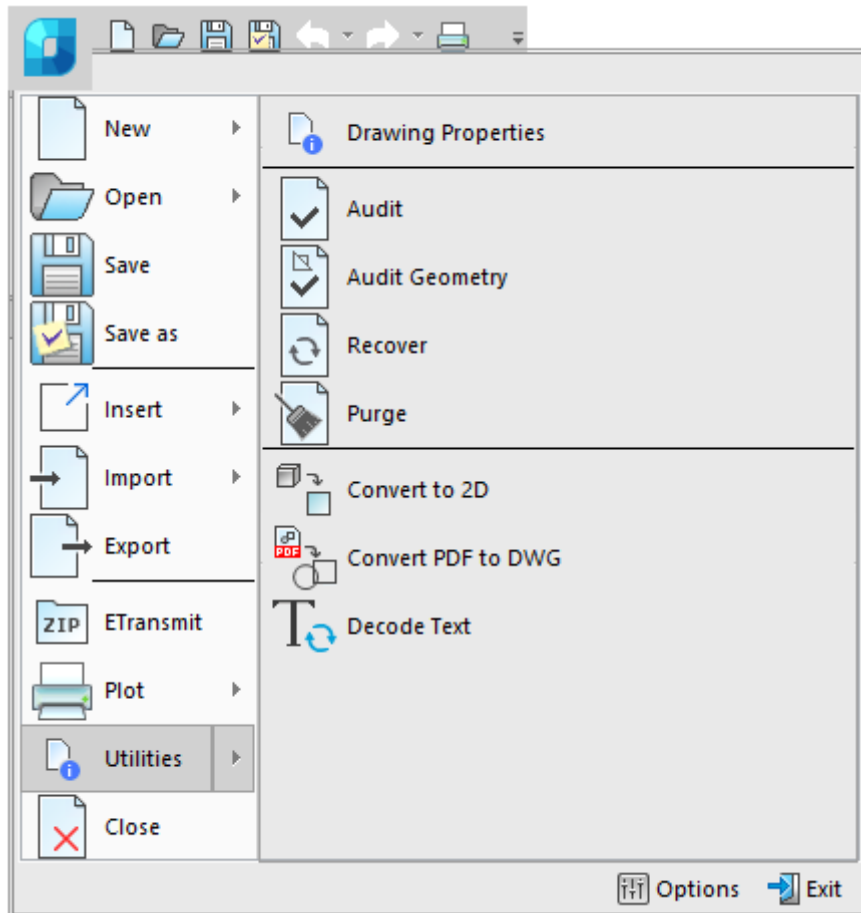

To open recently used file or folder with files, click its name in the list.

The  **Options** button opens the **Options** dialog box to manage nanoCAD settings.

## Quick Access Toolbar

The *Quick Access Toolbar* is placed at the top left of the nanoCAD window and contains most commonly used commands to create, open, save, and print a document. And the **Undo** and **Redo** commands for the changes you made to the document.

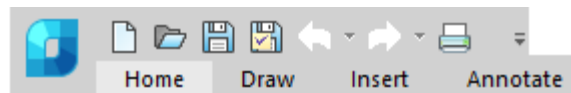

Use the context menu command **QAT toolbar below the ribbon** to place Quick Access Toolbar below the ribbon elements (this command is only available when the Ribbon is displayed).

## Ribbon

The *Ribbon* contains a set of tabs with controls and tools for creating and editing a drawing.

By default, ribbon is placed at the top of the nanoCAD window.

The ribbon view depends on the size of the program window. While the window width reduces, some buttons decrease their size. If shrinking continues, some of the command groups on the right side of the ribbon are collapsed into a drop-down menu.

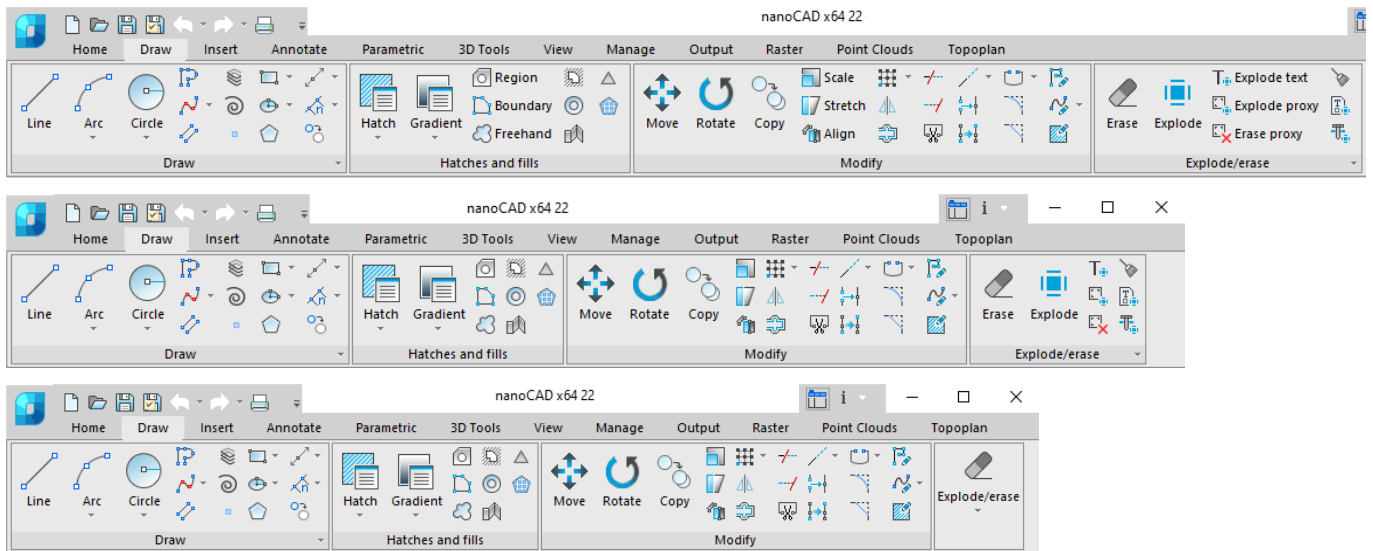

The  button in the upper right corner of the program window displays and hides the ribbon. When the ribbon is disabled, the program interface turns back to the main menu and toolbars.

The ribbon can also be enabled from the command line by the **RIBBON** command.

### Tabs

Tabs are displayed at the top of the ribbon. Tabs contains tools that are grouped to solve a certain type of task. To select a required tab, click its name on the tab.

### Groups

Each tab divides interface elements into *groups* – sets of command buttons and controls. The group names are located at the bottom of the ribbon.

### Command buttons

Each group contains commands to perform certain actions.

Clicking the arrow  in the group name caption, expands additional items (buttons and controls) of the group.

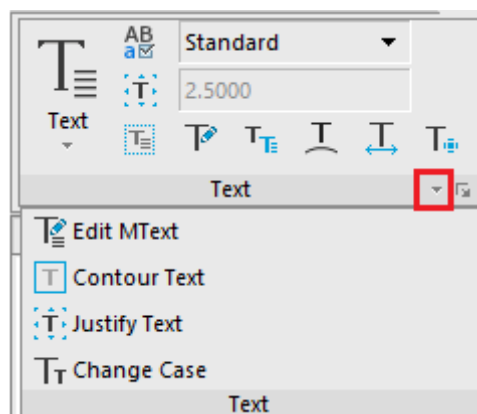

The button with the arrow , placed in the bottom right corner of group caption, opens the group setup dialog.

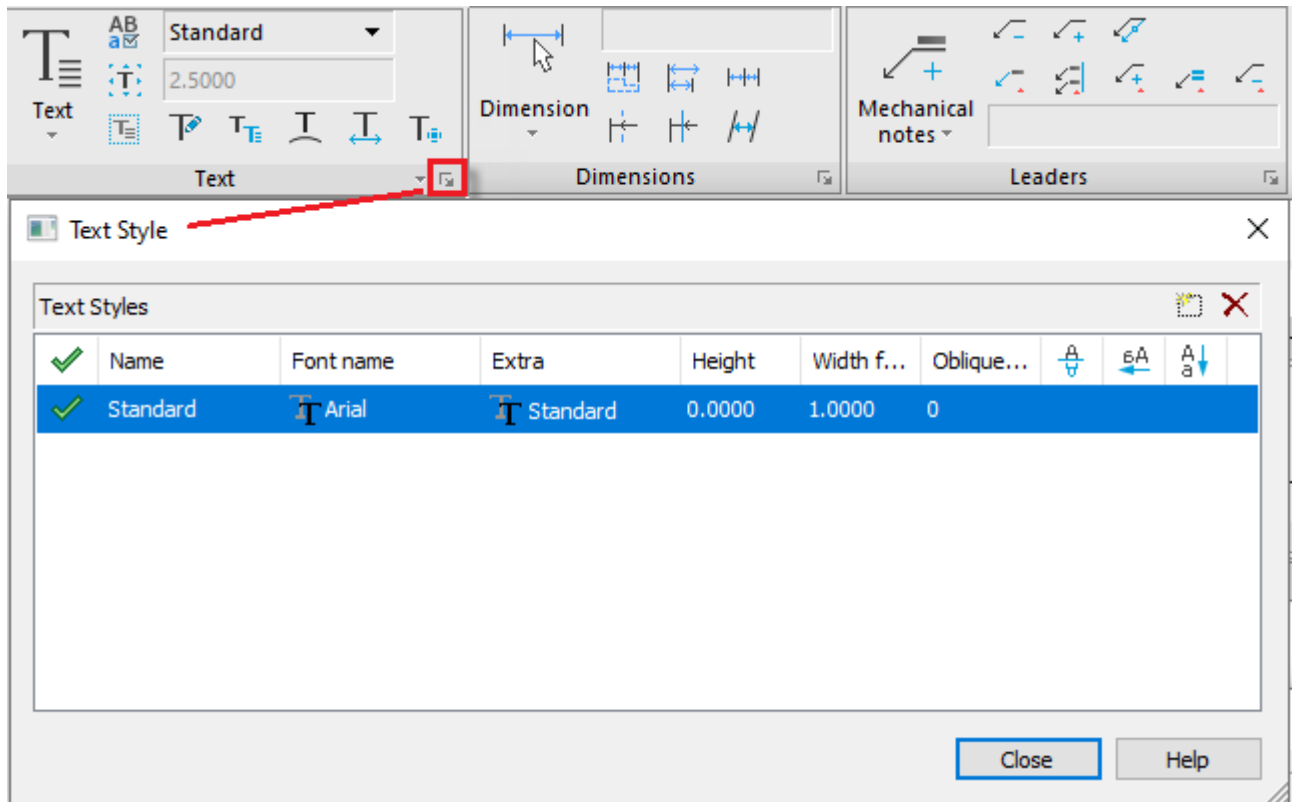

### Contextual tabs

Contextual tabs appear when editing blocks, external references or tables while working in paper space. These tabs contain specific groups of commands for working with selected items.

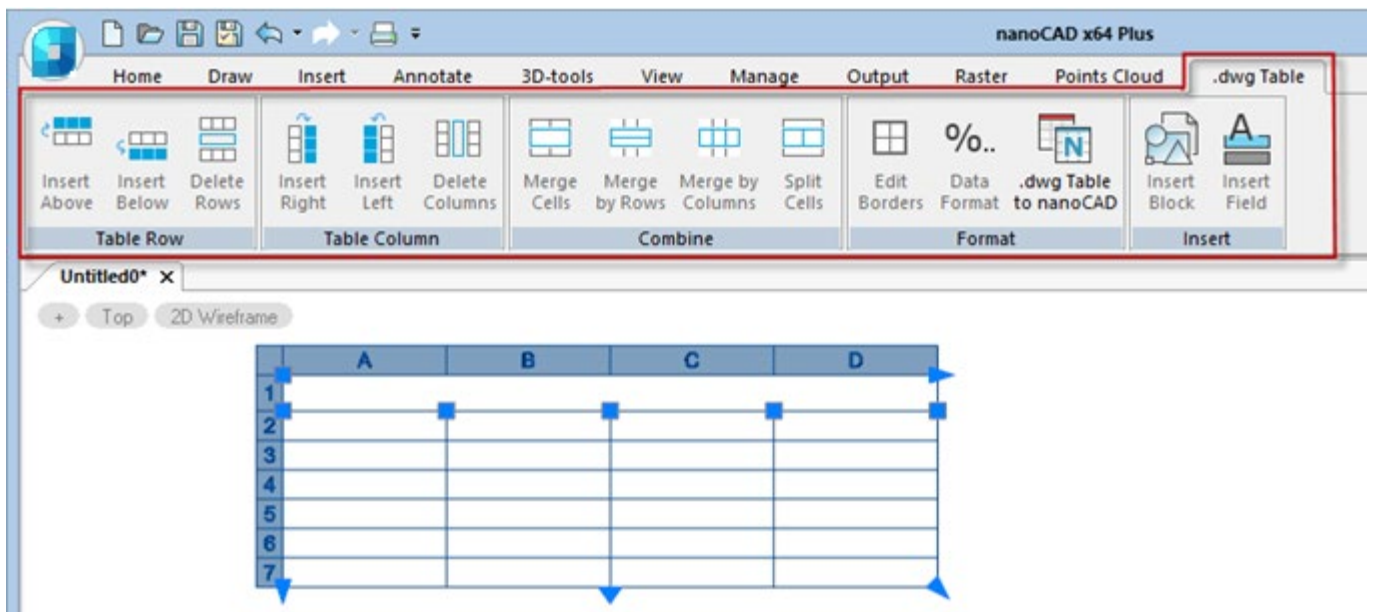

After you complete editing and exit the mode, the contextual tab closes.

### Ribbon displaying

Right-click in the ribbon area to customize its view with context menu:

- **QAT toolbar below the ribbon** – place **Quick Access Toolbar** below the ribbon.
- **Minimize Ribbon** – collapse the ribbon and show only tab names.
- **Customize interface**– opens the **Customize user interface** dialog.
- **Show tabs** – hide or show any tab.

- **Show panels** – hide or show groups. The list of groups depends on the ribbon active tab where context menu was opened.

You can edit the *composition* of controls and tools of the ribbon in the dialog [Customize User Interface > Ribbon tab](#) dialog.

## Main Menu

The *Menu bar* is placed at the top of the nanoCAD window and consists of drop-down menus containing all the basic commands.

Commands from the drop-down menus are grouped by functionality:

Menu	Description
<b>File</b>	Commands to work with files and documents: create, open, save, export and import files, print and print settings. There are also some useful utilities: audit, recover and purge documents, audit geometry.
<b>Edit</b>	<a href="#">Undo and redo commands</a> , exchange buffer commands, select commands, find and replace command.
<b>View</b>	<a href="#">Zoom commands</a> , creation of named views and viewports, views and visual styles, display of scroll bars, status bar and toolbars. Management of display of layout and document tabs, status bar, the <b>Selection</b> dialog.
<b>Insert</b>	Commands to insert <a href="#">blocks</a> and <a href="#">external references</a> , including <a href="#">raster images</a> , as well as commands to <a href="#">work with layouts</a> (create, save, delete and rename, as well as <a href="#">Layouts Manager</a> ).
<b>Format</b>	Commands to work with <a href="#">layers</a> , <a href="#">line types</a> , <a href="#">text styles</a> and <a href="#">dimension styles</a> , point styles, units and drawing limits.
<b>Tools</b>	<a href="#">Display order commands</a> , edit blocks and external references, drafting settings and program options.
<b>Draw</b>	<a href="#">Commands to draw objects</a> .
<b>3D</b>	Commands to create and modify 3D-objects, assembly sketches, projection views and sections. The functionality is available if you have a separate license and the <b>3D modeling</b> box is checked in the <b>Licensing</b> section of the <b>Options</b> dialog..
<b>Dimensions</b>	Commands to <a href="#">set dimensions</a> and manage <a href="#">dimension styles</a> .
<b>Modify</b>	Commands to edit drawing objects.
<b>Constraints</b>	Comamnds to set parametric and geometric 2D-constraints, their display and editing theur parameters. The functionality is available if you have a separate license and the <b>2D constraints</b> box is checked in the <b>Licensing</b> section of the <b>Options</b> dialog..
<b>Raster</b>	Commands to edit raster images. If you have a separate license and the <b>Raster</b> box checked in the <a href="#">Licensing</a> section of the <b>Settings</b> dialog, this makes available an advanced functionality, which includes a vast set of raster selection methods, image calibration, filtering with various algorithms, changing size and resolution, binarization, recognition of text areas and line objects on a raster. And also the functionality of converting raster data into a vector representation and back: automatic and semi-automatic vectorization in various modes, rasterization of vector objects.
<b>Point clouds</b>	Commands to import point clouds from known formats, display them, crop, obtain information and statistics..



<b>Topoplan</b>	If you have a separate license and the <b>Topoplan</b> checked in the <a href="#">Licensing</a> section of the <b>Settings</b> dialog, this makes available the <b>Topoplan</b> module intended to create a digital terrain model and prepare a drawing for release of topographic plans.
<b>Help</b>	Help and useful links.

The graphic interface of the drop-down menus contains a set of symbols to make work with the menus easier:

- commands from each functional group are separated by lines in the drop-down menu:

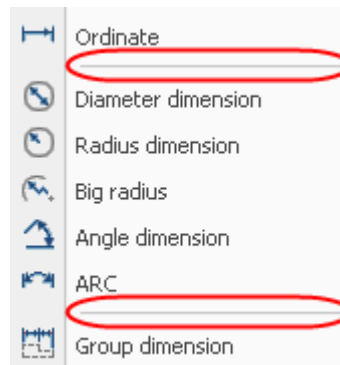

- a small black triangle on the right side of the menu indicates that selection of the item opens a cascade menu:

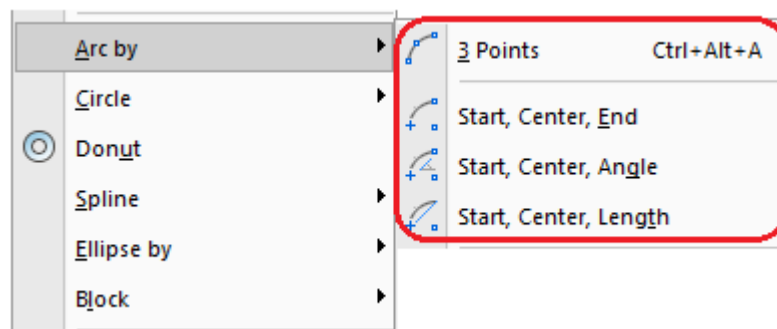

- three dots at the end of the menu item means that the item opens a dialog box:

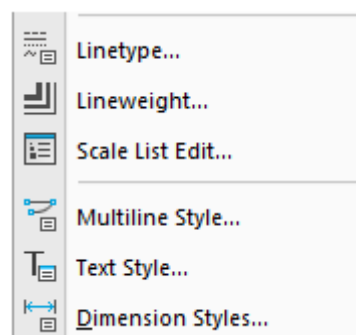

- there are hotkeys to the right of the most used commands:

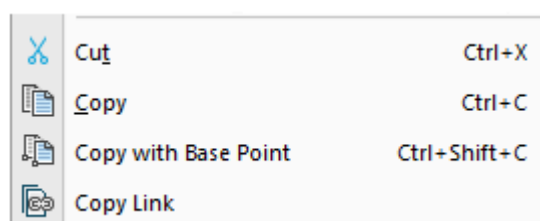

## Toolbars

Buttons on *the toolbars* are used to start the commands. When you move the cursor over the button the tooltip is shown:

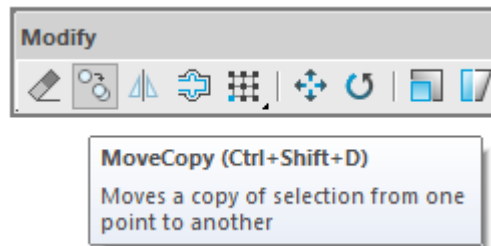

On some toolbars the commands are grouped and you can see only one button of command from each group.

The buttons from the command groups are marked with small arrows in the bottom right corner:



When clicking such a button, a toolbar opens showing the tools of the specified group. To select the required tool from the group, move the cursor to the button on the bar and select it.

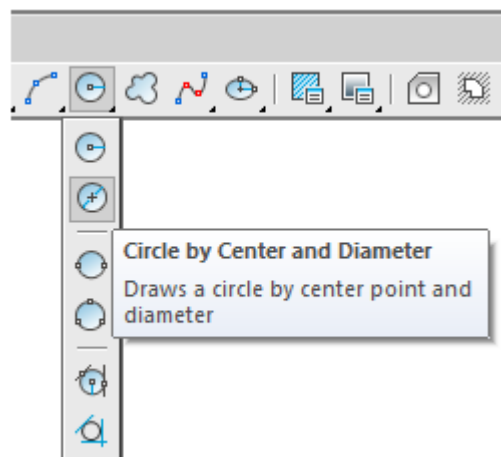

Show or hide toolbars by selecting **View – Toolbars > nanoCAD toolbars**; or from the context menu of any toolbar.

Toolbars can be moved to any part of the program window.

A toolbar in the document area is called moving or floating. You can change its shape and location. To fix a toolbar to one of edges of the document area, move it out of the document area. This toolbar is called fixed.

Location of panels, fixed and floating toolbars can be locked against accidental moving.

Fixing control commands are located in the context menu of any toolbar:

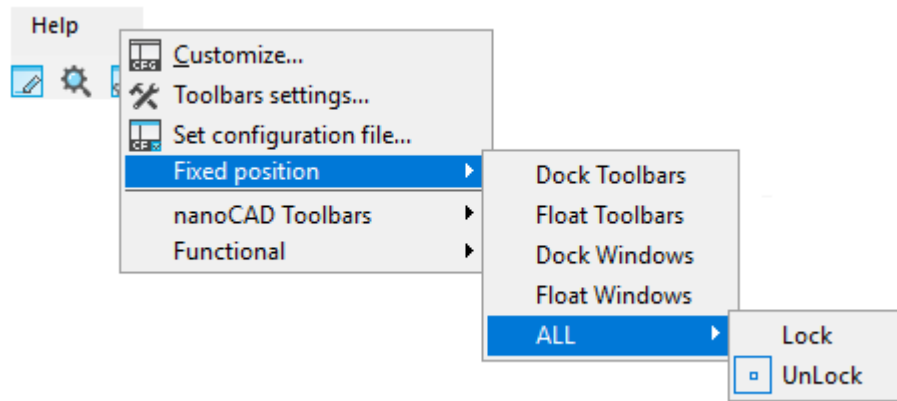

and in the menu **View – Toolbars - > Fixed position:**

- **Dock toolbars**
- **Float toolbars**
- **Dock windows**
- **Float windows**
- **All > Lock / Unlock**

For temporary unlocking to move or close a fixed toolbar, press and hold **CTRL**.

## Drawing Window

There are *drawing windows* in the nanoCAD. Each document is opened in a separate window. If several documents are opened in the program, use the *tabs* to select the required document.

In the top of the graphic area, there are tools to control views, projections and visual styles of a model.

*View control* – the tool contains drop-down menus to select view and visual style of a drawing.



*Locator* – shows the current model orientation and allows for quick switch between orthographic, intermediate and isometric views or set any arbitrary view.

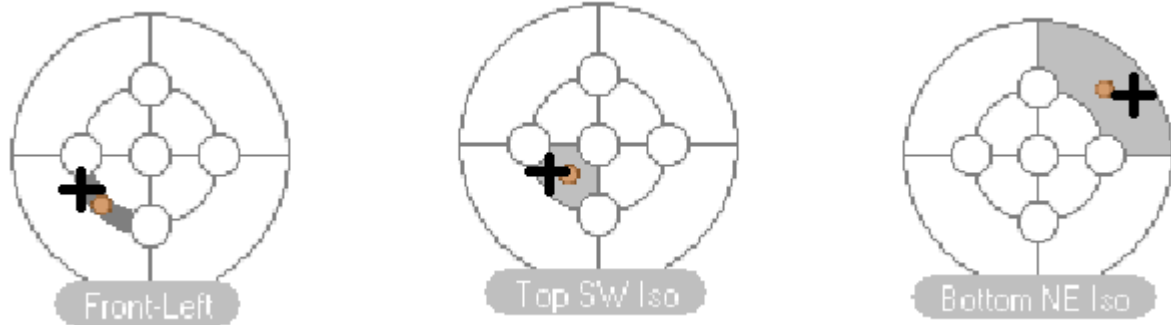

Conceptually, the locator is a conditional sweep of sphere to plane.

The display of *Locator* and *View control* on the screen is controlled through the menu of sign 

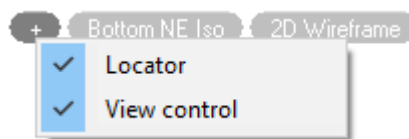

### User coordinate system icon (UCS)

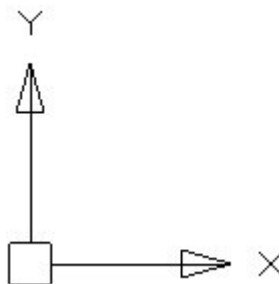

is placed in the default coordinates:  $X=0$ ;  $Y=0$ ;  $Z=0$  (in the bottom left corner). To show/hide the icon, select the **View** menu – **Display > UCS icon**.

*Cursor* – the main instrument for selection and specifying in the drawing area. The cursor has a crosshair shape with a square sight at the intersection point:

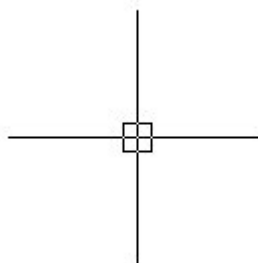

The shape and size of the cursor can be adjusted in the **Cursor** section of the **Options** dialog box (**Tools** menu – **Options**).

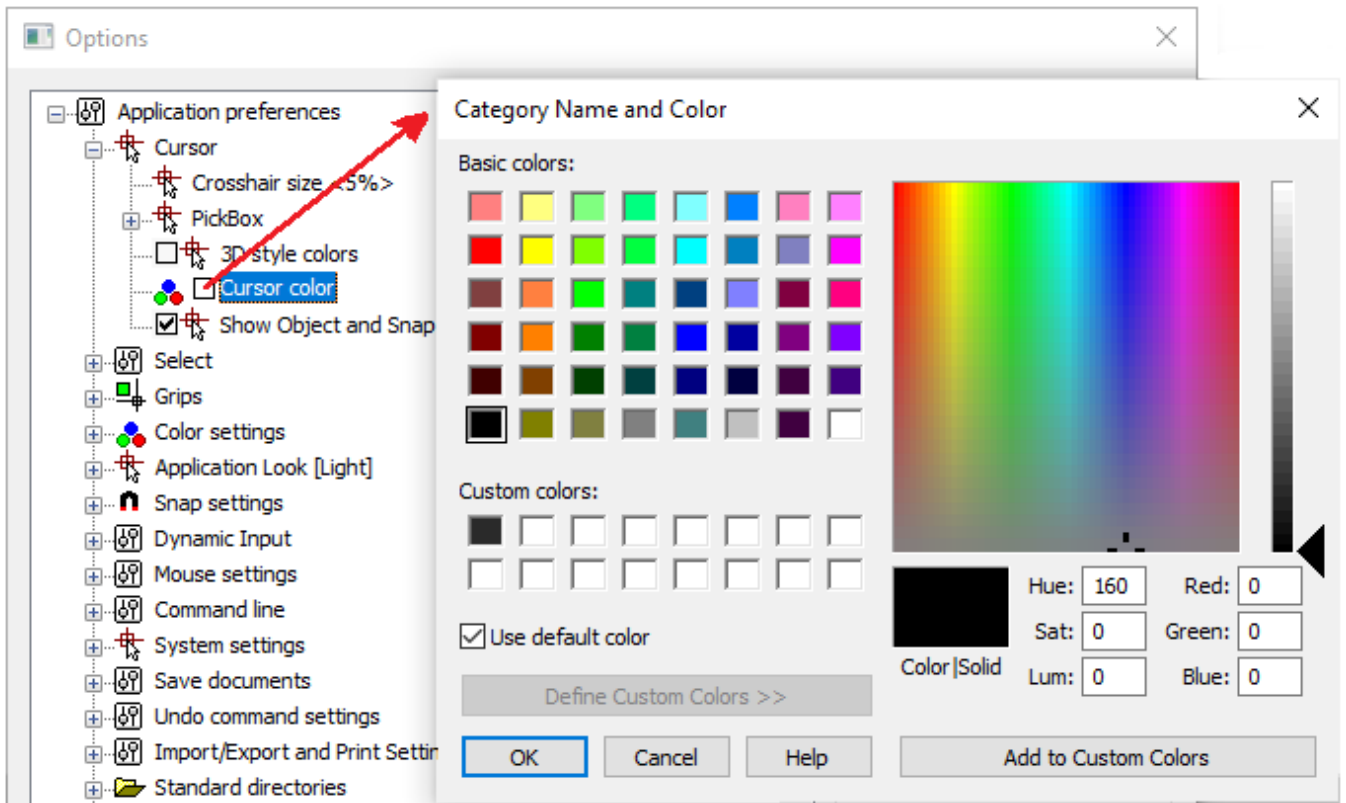



**ATTENTION!** To change the cursor's color, deselect the **Use default color** box in the **Category Name and Color** dialog box

Outside the graphic area, the cursor has an arrow shape:  .

The *document layouts' tabs* in the bottom part of the window are used to switch between layouts and to switch from *model space* to *paper space* and back. It can be more useful to use the  button located at the end of *tabs row*. The button allows switching between layouts and *named views* in the document (for more information see the "Model space and Paper space" section). *Scroll bars* in the bottom and left parts of the graphic area are additional tools for panning. The **Scroll bars** command from the **View** menu shows/hides the vertical scroll bar. The horizontal scroll bar is always shown.

Commands that manage sheets and documents tabs displaying are located in the **View** menu and on the ribbon – **Options** tab – **Customization** group:

-  **Document tab**
-  **Sheets tabs**
-  **Show tabs**

## Context Menu

In nanoCAD, as in many other Windows applications, the *context menu* appears when you click the right button. The content of the context menu depends on the current context – object type, location of the cursor and what command is being run at the moment.

Examples of the context menu

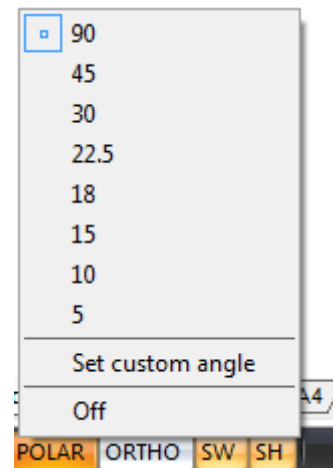
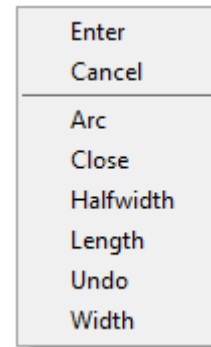
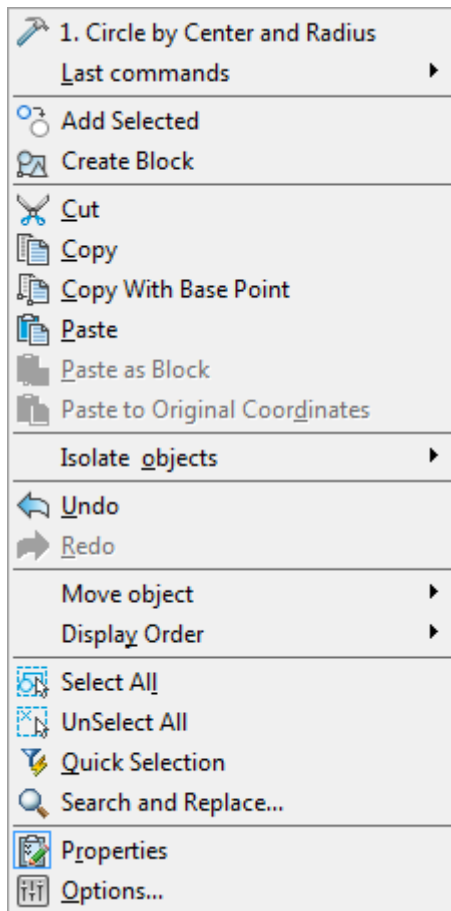

**NOTE:** Right button clicking with **SHIFT** or **CTRL** pressed during the execution of a command for creating or editing objects opens the context menu of the **Object snap**:

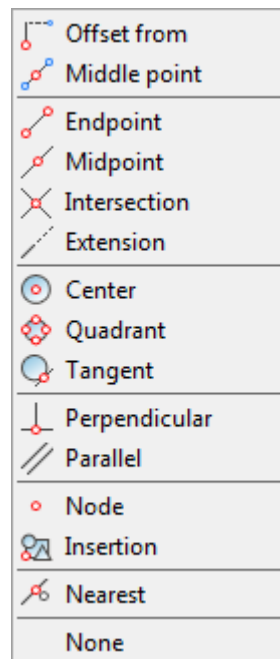

## Properties Bar

Functional bars are non-modal dialog boxes.

In most cases functional bars display certain information (about current document, selected objects, change history, etc.), allow you to change some of displayed parameters or apply

certain actions or commands to them. It is convenient to keep these panels open during the program work.

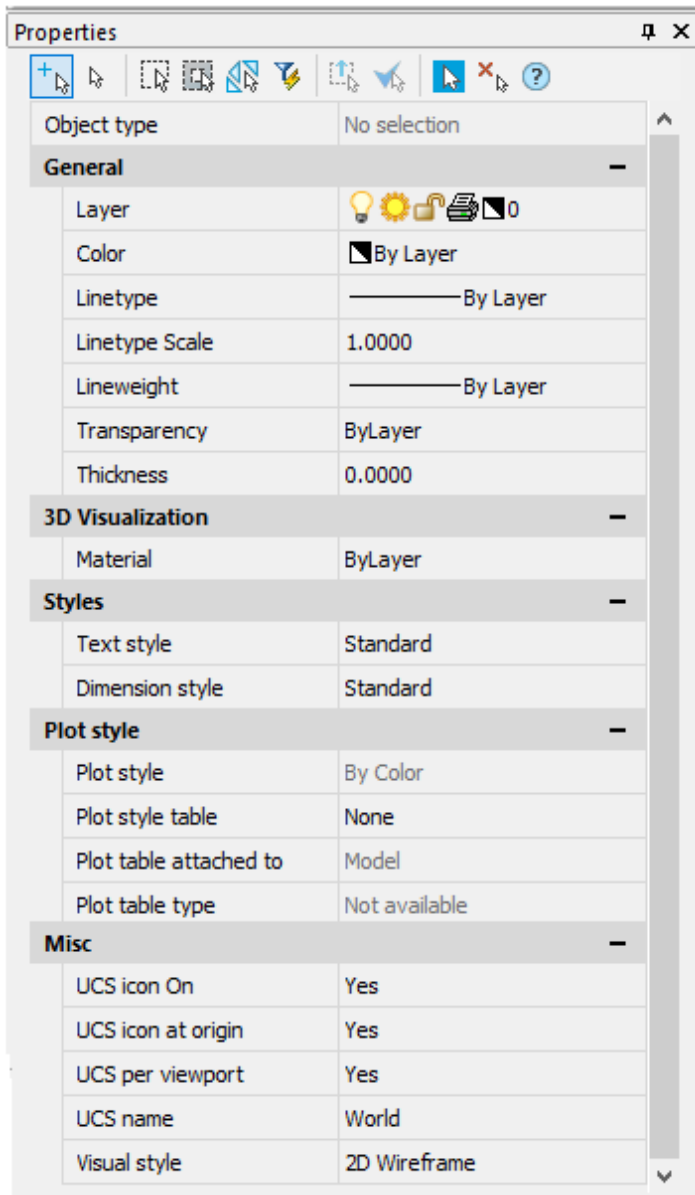

Functional bars have a number of advantages over regular dialog boxes:

Unlike dialog boxes, active functional bars do not prevent from full-fledged work with documents, performing any commands.

You can keep open several bars simultaneously.

They update their content on the fly reflecting (and allowing to edit) up-to date information about a drawing, its properties and objects.

Thus, for example, **Properties** bar is used to display options of selected objects, to change objects' properties, as well as to set selection mode and launch selection commands.

You can combine functional bars in single blocks, attach them to edges of other parts of interface, switch them using tabs.

When switching to another drawing or workspace, they change their content displaying information and parameters relevant to the current workspace and drawing.

The *Properties bar* is used to display information about selected objects, to change objects' properties, to set selection mode and to launch selection commands.

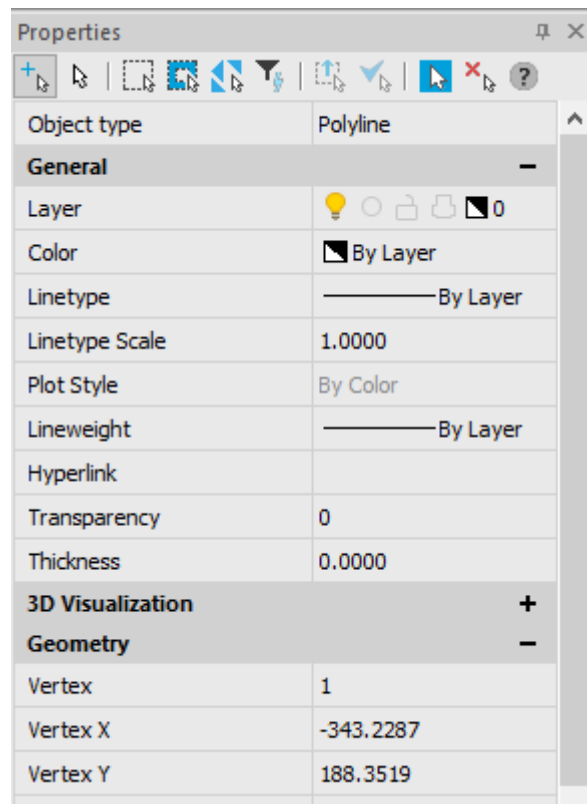

The **Properties** bar can be combined with other functional bars, such as **Quick Selection**, **Drawing Explorer**, **Tool Palettes** and other. You can switch between merged functional bars using tabs in the bottom part.

Functional bars can be shown/hidden from **View – Toolbars > Functional** menu or from right-button menu in toolbars area.

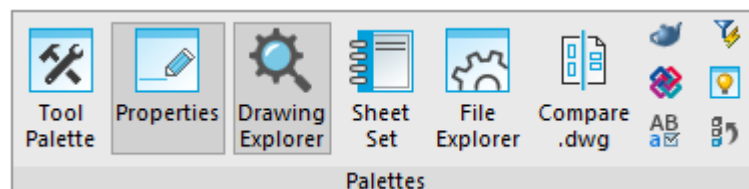



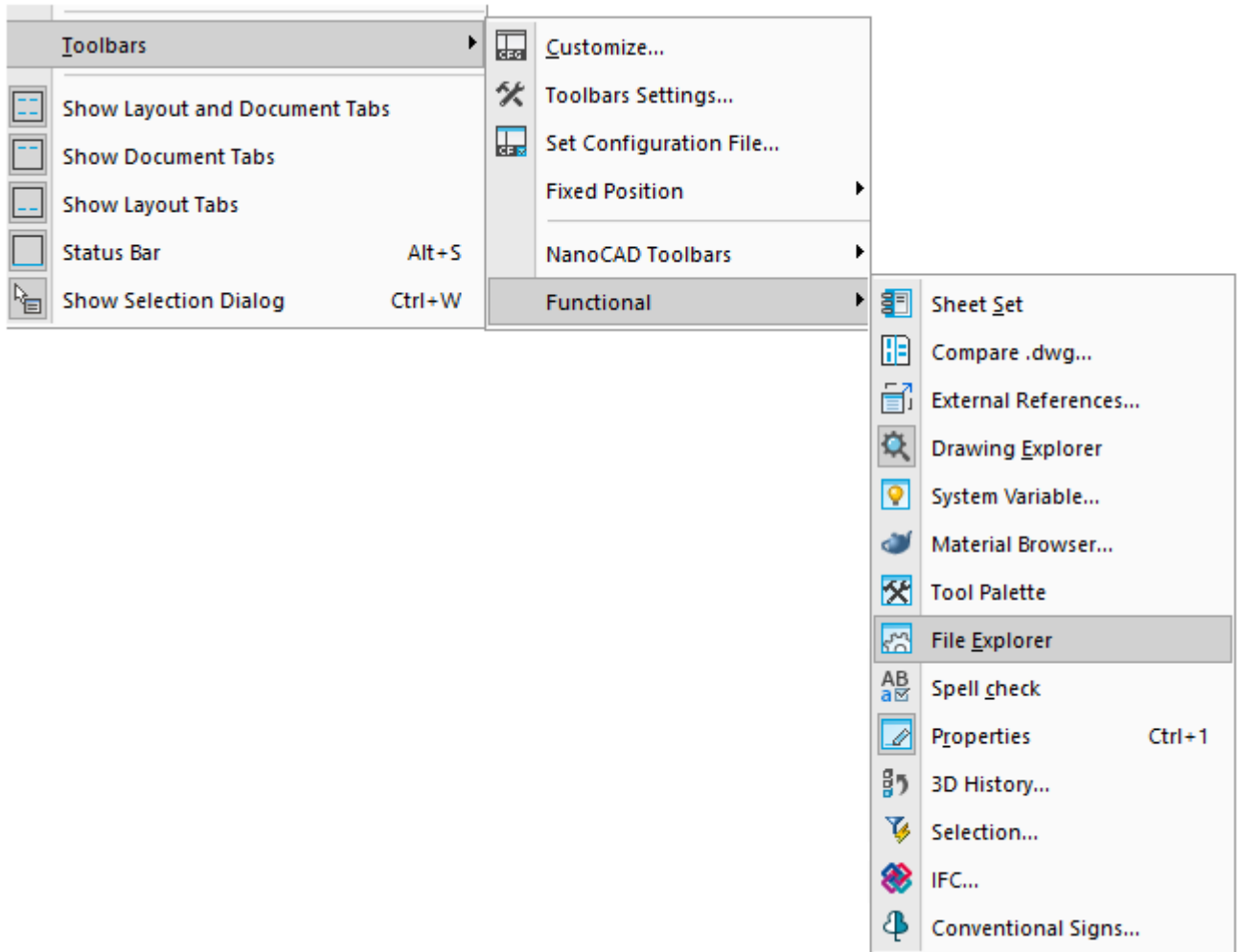

as well as in the context menu called by the right mouse click at any toolbar.

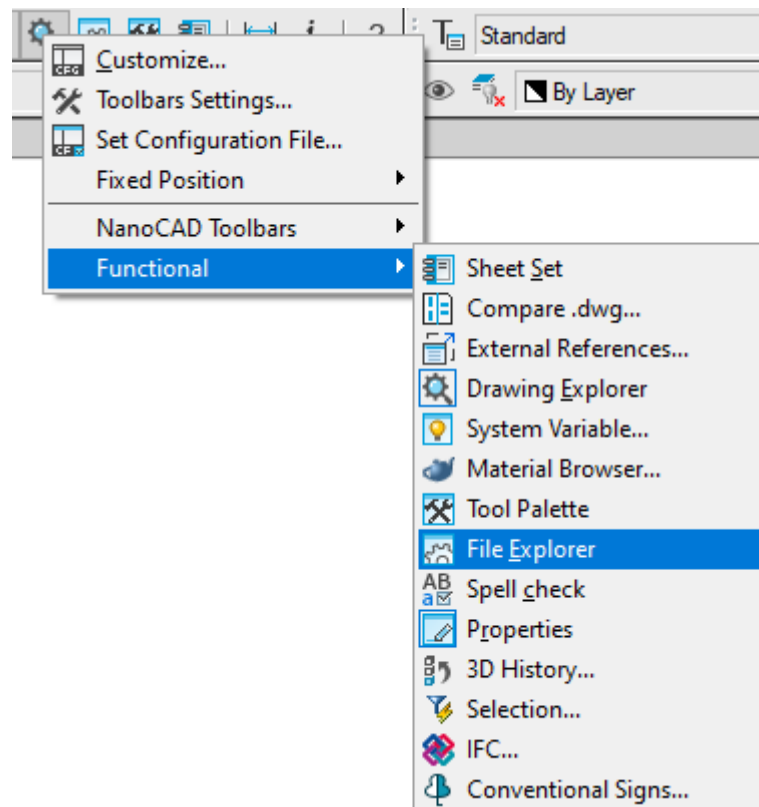

### Combining tool palettes

To save drawing space, tool palettes can be combined. In this case only the active palette will be displayed on the screen, while the rest ones combined with it will be displayed as bookmarks. You can switch between combined palettes using bookmarks located in the bottom of the active palette.

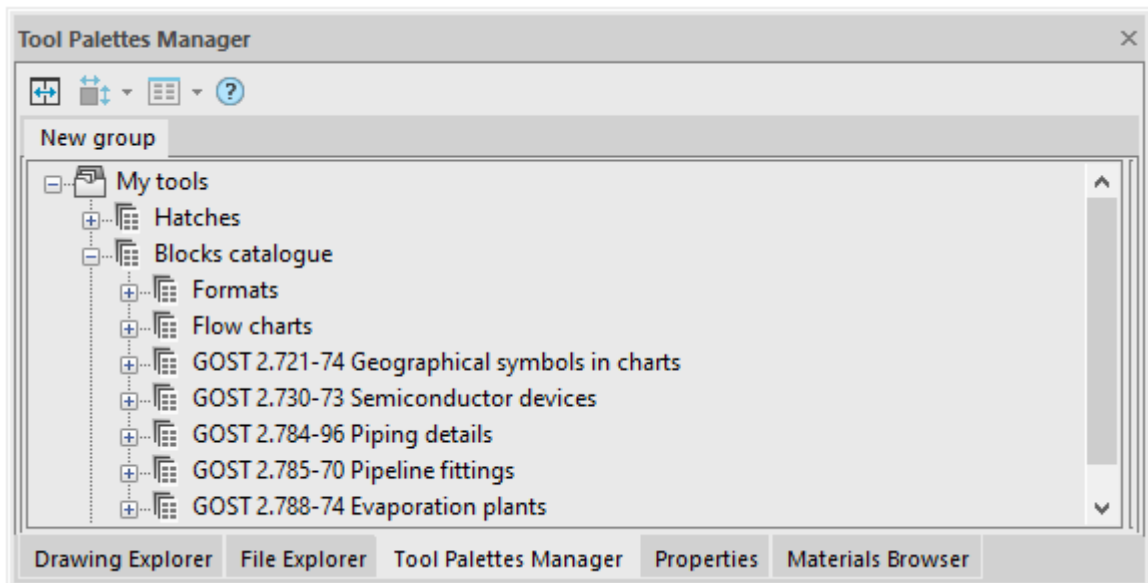

To combine tool palettes, drag the title of one palette onto the title of another one. The order of tabs can be changed by dragging. To separate a palette, click on its tab and drag it into a drawing field holding the mouse button.

### Attaching tool palettes

The position of interface elements is changed by their dragging with the mouse pointer by the header.

1. Press the left mouse button on the tool palette header and, holding the button down, drag it to the field of the window to which the palette being moved should be attached. An icon will appear in the center of the window, which allows you to specify the place of attaching the palette in this window.
2. Continuing to hold the mouse button down, move the cursor over one of the icons:

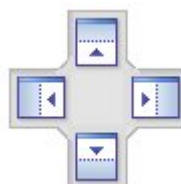

The outermost icons are used to attach a palette to one of the window sides, the central one – to attach a palette as a tab.

The future position of a tool palette will be indicated with a blue field in the window. If this position is satisfactory – release the mouse button.

A palette attached to the window can be switched to the state of a pop-up tab. To do this, click on a pushpin icon in the toolbar header:

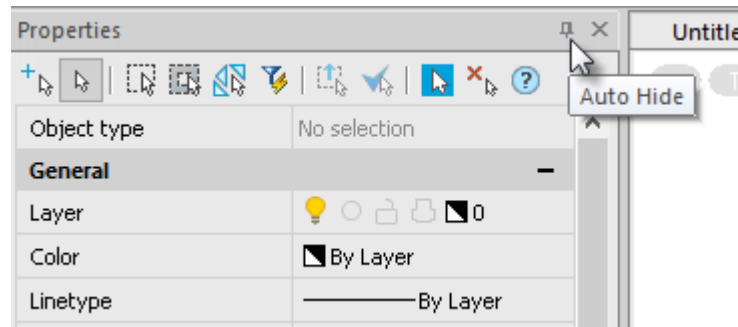

In addition, the context menu with methods of attaching and displaying is available:

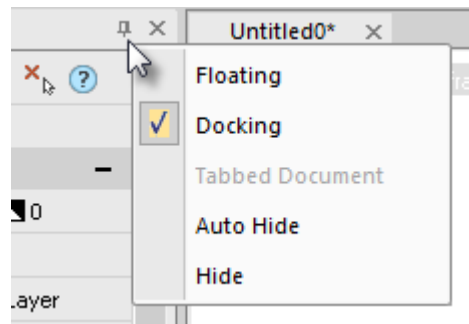

## Command Line

The *command line* is used to enter commands from the keyboard, to show tooltips and nanoCAD messages, to select the options of the selected command:

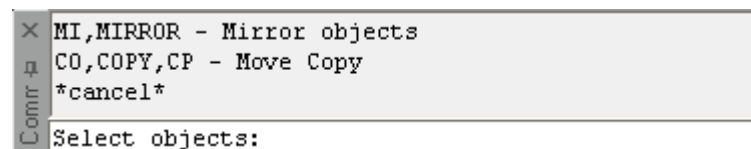

An accidentally closed command line will appear again after calling any command. If this did not happen, you can use the [Restore UI state](#) command.

The default command line height is set to display 4 lines of command history. To move from one line to another, use the scroll bar in the right part of the command line window. The height of the command line can be changed by dragging the top edge and dropping it in the required place.

In the Command line section of the **Options** dialog you can change the text and background color of the command line, switch on/off **Use Autocomplete** and **Use alternate font** options:

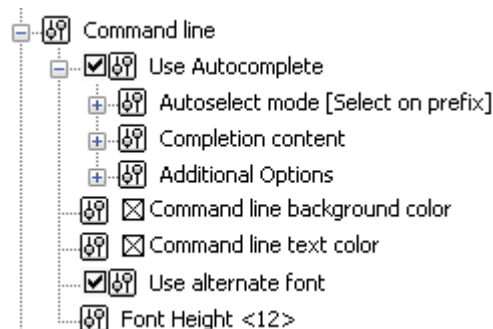

## Input of Commands, Aliases and Shortcuts

To enter a command from the keyboard, type the full command name in the command line and press **ENTER** or **SPACEBAR** to execute it

Instead of the full name of the command you can use a command abbreviation, the so-called *alias* of command. For example, instead of typing **CIRCLE**, you can just type **C**.

Several aliases can be assigned to one command. However, a particular alias can only be assigned to one command. Aliases are specified in *nCAD.pgp* file.

*Shortcuts* are similar to aliases, but launch a set of commands grouped by a certain criterion.

**NOTE:** It does not matter what case is used when typing in the command line.

With the **Use Autocomplete** mode (**Command line** section of the **Options** dialog box) you can choose a command from the list displayed in the command line after you have entered several letters:

- command;

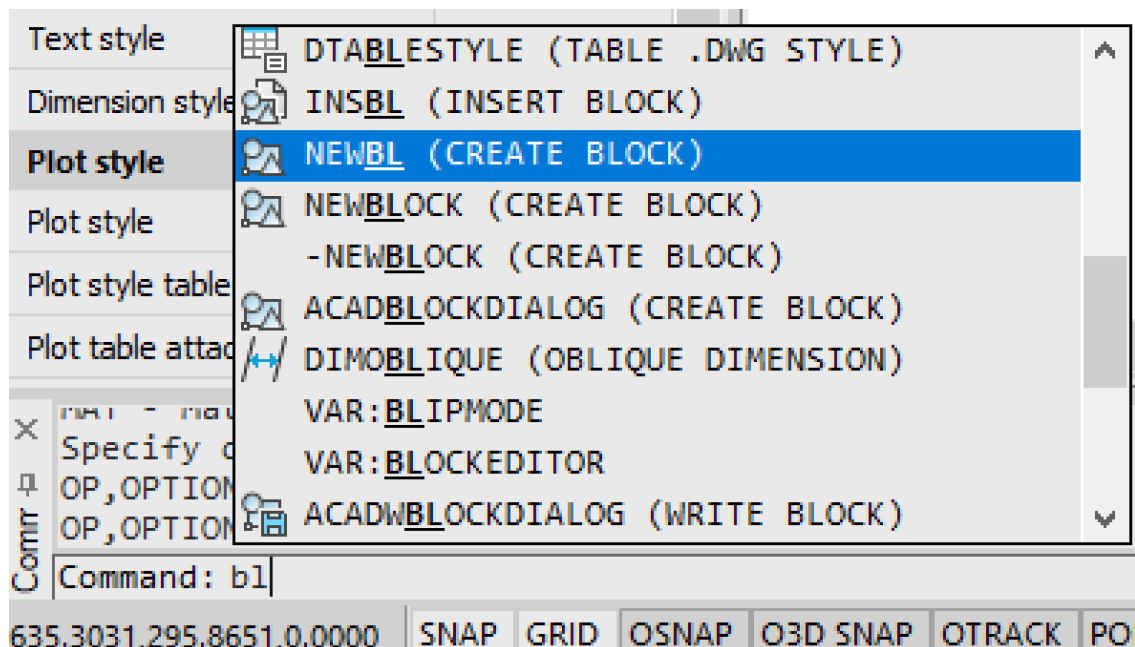

- system variable (indicated with VAR: in the autocomplete list);

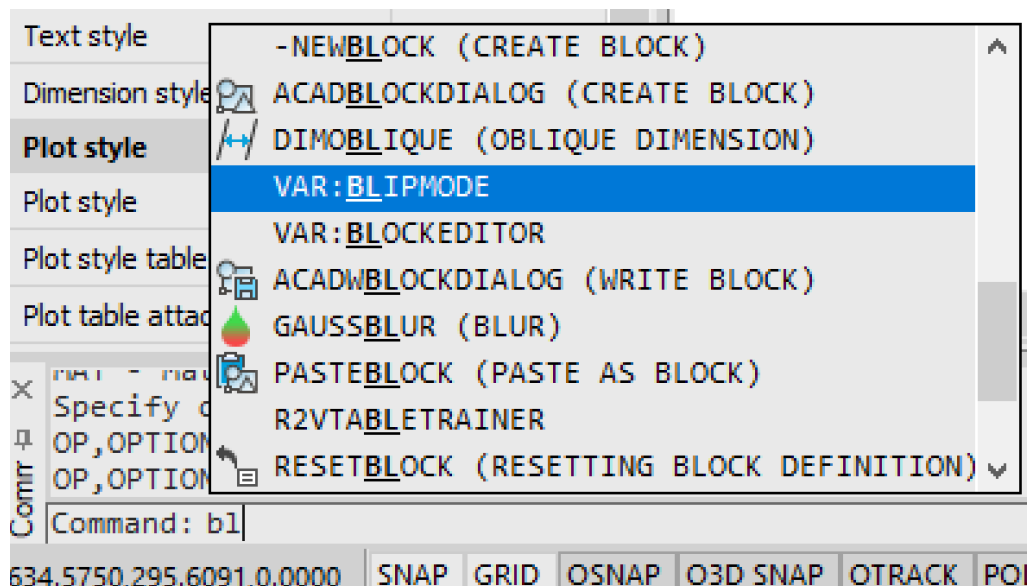

- a block present in the document (indicated with BLOCK: prefix in the autocomplete list).



The **VAR:** command allows you to display only system variables in the autocomplete list:

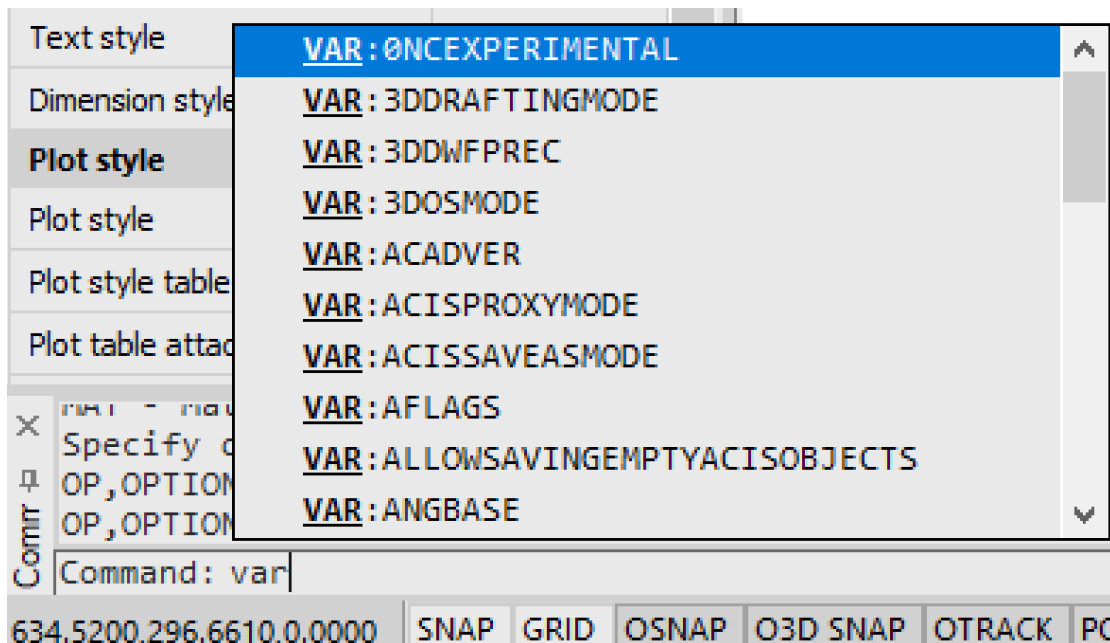

The addition of system variables and blocks in the autocomplete list is managed by the relevant options of the **Command line** section of the **Settings** dialog

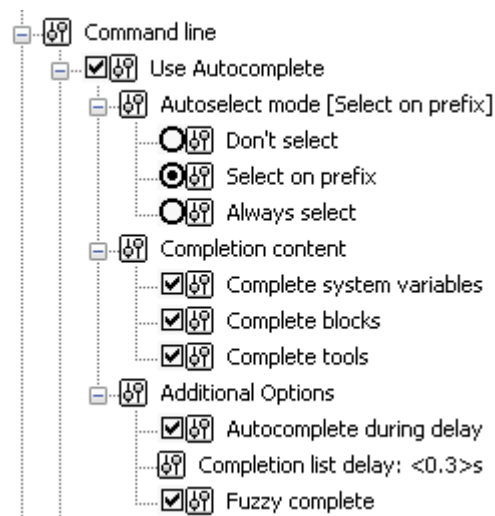

When enabling the **Use Autocomplete** mode (the **Command line** section of the **Options** dialog), the autocomplete list includes additionally also the results of search based on fuzzy logic, i.e. search of parts of input line not only in the beginning, but throughout the entire name with automatic correction of possible input errors.

The time delay in display of autocomplete list is managed by the **AUTOCOMPLETEDELAY** system variable. The default value is 0,3 seconds. The maximum permitted value is 10 seconds.

To select a command from the list use **TAB**, **ARROW UP**, **ARROW DOWN** buttons and the **ENTER** button to confirm a selection.

You can see a full list of registered commands, aliases and shortcuts in the command line by entering an apostrophe.

**NOTE:** The autocomplete list is displayed not only in the command line, but also in using the Dynamic input.

## Text Window

To display the *command history*, press **F2** to open the text window:

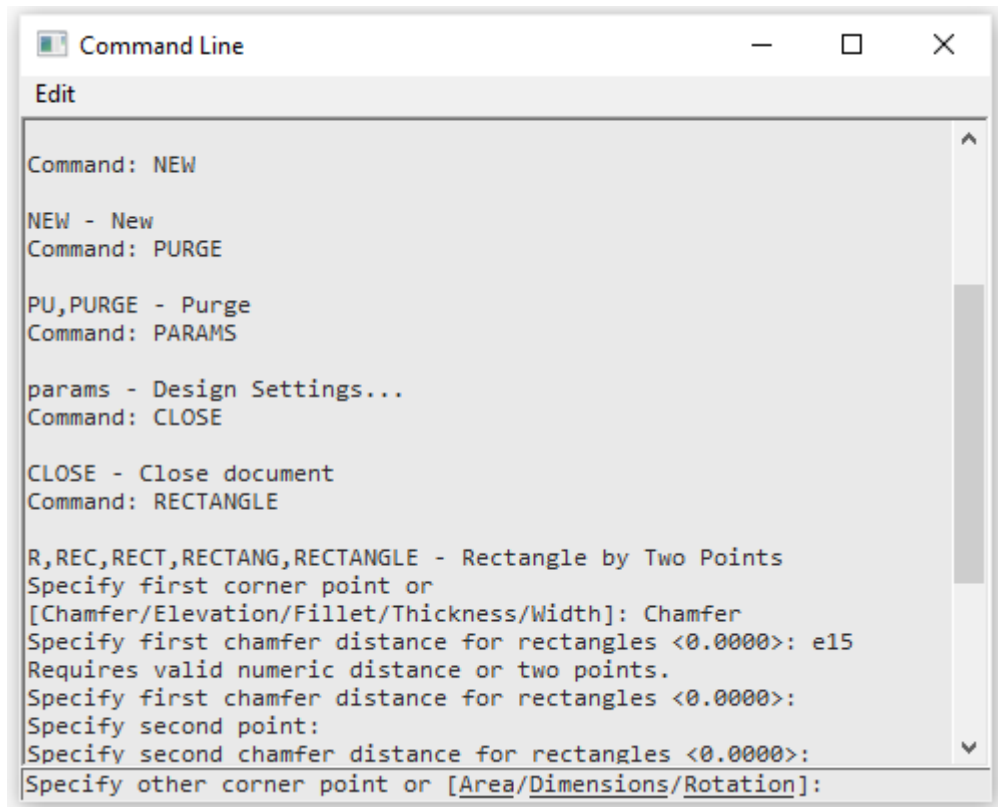

You can close and open the window at any time.

The window is opened at the same location and size as set previously.

## Command Line Prompt

The default command line prompt looks like:

Command:

but it varies depending on the current command or program state.

The command prompt can include descriptive messages that are displayed in the status bar when the command is running. For example, the prompt during a creation of a circle is:

Specify center point for circle or [3P/2P/TTR]:

It can also include interactive keywords in square brackets separated by a slash, highlighted in a blue color and underlined.

**NOTE:** To prevent confusion with hyperlinks, interactive keywords in prompts are shown in a red color and bold font.

You can type any keyword manually or just click on it. A keyword specified in triangular brackets is a keyword "by default".

**For example:**

Enter number of sides <4>:

or

Extend <Inscribed> or [Inscribed/Circumscribed]:

To choose it press the **ENTER** key.

As an answer to the prompt, type the keyword, or you can just type the capital letter of the word:

Specify next point or [Arc/Close/Halfwidth/Length/Undo/Width]:

For example, to select the Close keyword, type **C** and to select Undo type **U**.

**NOTE:** The capital letter can be in the middle of the key word.

## Format of Input Data

You can enter different formats of data, text, digital values, coordinates, in the command line.

To use coordinate values to specify a point, enter an X value and a Y value separated by a comma <X,Y>:

23.45,-6.98

If the angle units are degrees/minutes/seconds, the following syntax is used:

32d20m10s or 32-20-10

## Mathematical Processor

The command line allows for the input not only of commands, numbers and points, but also mathematical expressions. It is convenient when the coordinate or number is not known beforehand but should be calculated from some conditions.

For example, instead of calculating the coordinate of a point using the  $\text{SQRT}(349.56-275.90)*2$  formula and only then typing it in the command line, like here:

Command: L,LINE - Line by points

First point: -12.45,17.17

You can use a mathematical expression instead of coordinates in the command line:

Command: L,LINE - Line by points

First point: -12.45,SQRT(349.56-275.90)\*2

To calculate a mathematical expression at any time type the ? sign before this expression. In the following example, a multiplication operation is performed during the line creation process.

Command: ?25.7\*5

After pressing **ENTER** the result is shown in the command line:

?25.7\*5 = 128.5

Mathematical expressions can be calculated during the execution of some commands. The following example shows a multiplication expression calculation during drawing a line:

```
Command: L,LINE - Line by points
First point: 25.7,41.32
Next point: 25.7*5,93.77
```

After you press **ENTER**, the line with first point coordinates (25.7, 41.32) and end point coordinates (128.5, 93.77) will be drawn.

The complete list of registered operations, functions and constants can be viewed in the **Command Line** window by entering the **?** sign and press the **ENTER**.

The Mathematical processor supports the following arithmetical operations, constants and functions:

**Constants:**

<b>E</b>	The constant e, the base of natural logarithms.
<b>PI</b>	The constant pi. It represents the ratio of the circumference of a circle to its diameter.

**Arithmetic operations:**

<b>( )</b>	Groups expressions.
<b>+</b>	Adds.
<b>-</b>	Subtracts.
<b>*</b>	Multiplies.
<b>/</b>	Divides.
<b>%</b>	Remainder.
<b>**</b>	Power.

**Functions:**

<b>COS</b>	Returns the cosine of a number.
<b>SIN</b>	Returns the sine of a number.
<b>TAN</b>	Returns the tangent of a number.
<b>ACOS</b>	Returns the arccosine of a number.
<b>ASIN</b>	Returns the arcsine of a number.
<b>ATAN</b>	Returns the arctangent of a number.
<b>ABS</b>	Returns the absolute value of a number.
<b>EXP</b>	Returns e (the base of natural logarithms) rose to a power.
<b>LN</b>	Returns the natural logarithm of a number.
<b>LOG</b>	Returns the base-10 logarithm of a number.
<b>SQRT</b>	Returns the square root of a number. The number must be non-negative.
<b>FLOOR</b>	Returns the largest integer less than or equal to the given numeric expression.
<b>CEIL</b>	Returns the smallest integer greater than or equal to the given numeric expression.
<b>FRAC</b>	Returns a locale-specific count of the number of digits to display to the right of any decimal point.
<b>TRUNC</b>	Returns the integral digits of the specified number. Any fractional digits are



	discarded.
<b>ROUND (x,precision)</b>	Returns a number rounded to a specified number of decimal places (precision). Precision value indicating how many places to the right of the decimal are included in the rounding.
<b>NEG</b>	Returns the negative value of a number.
<b>SGN</b>	Returns an integer indicating the sign of a number: 1 - Greater than zero; 0 - Equal to zero; -1 - Less than zero.

The user defined variables can be used in calculation expressions. The variable is created using the following syntax:

?<variable>=<value>

**For example:**

?base=100

Command: L,LINE - Line by points

Specify first point: base+11.56,base-5

Specify next point: base+27,base+35

A segment with the first point coordinates (111,95) and the end point coordinates (127,135) is built.

## Auto Hide Mode in the Command Line

The command line can be placed in *Auto Hide mode* to enlarge the working area. In this mode the command line is reduced to a tab. In the tab name you can always see the command line's message and entered values.

To Auto Hide the command line select the pin icon:

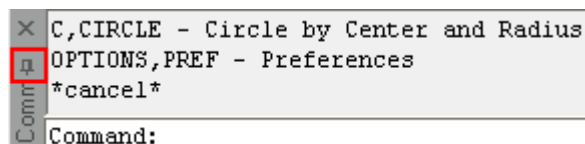

Or select from the context menu the **Auto Hide** command:

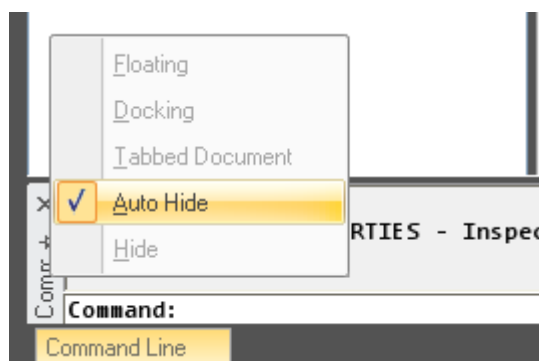

In the Auto hide mode the command line folds into a tab.

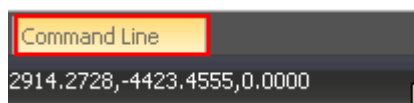

The value you enter and the command line prompt are always displayed in the tab's name:

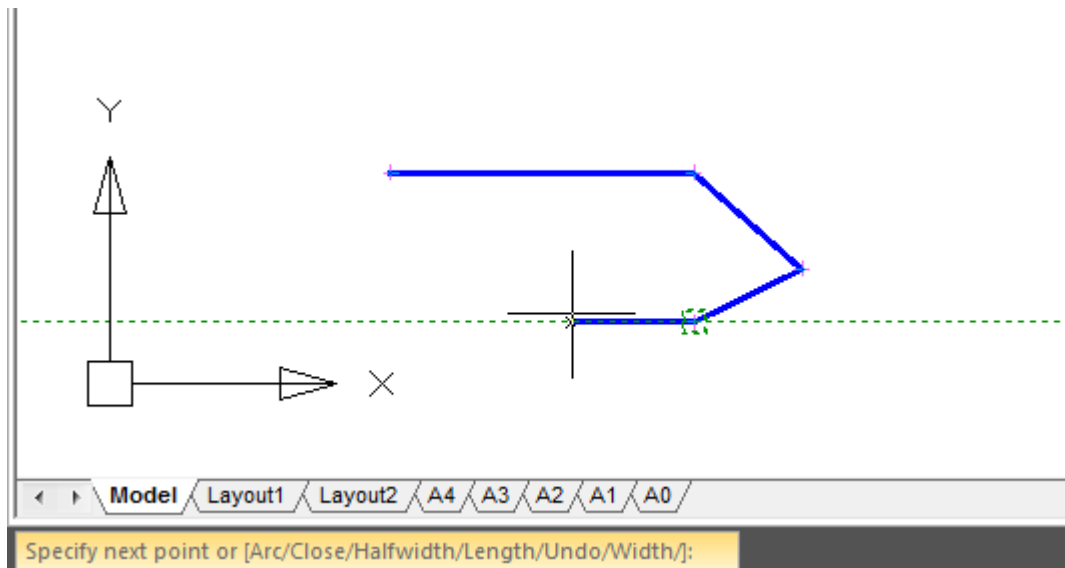

When moving the cursor over the tab, the command line expands to its full size, and when moving the cursor away it folds again:

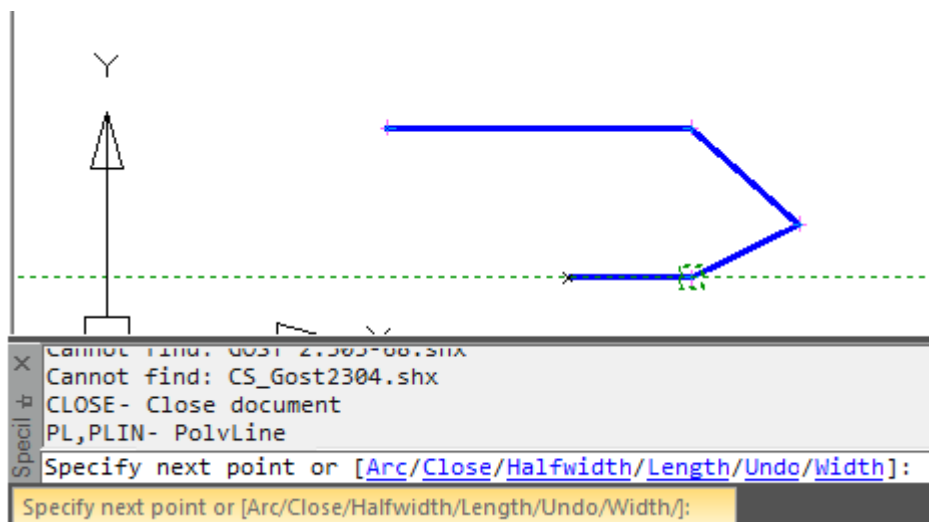

The entry of commands and required values is performed without showing the command line.

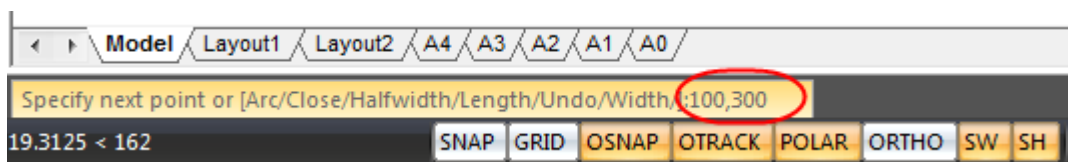





## Working with Commands

Commands are used to create and edit objects, open dialog and start any other operations. Commands can be launched:

- from nanoCAD button menu;
- from the quick access toolbar;
- from the ribbon;
- from the main menu;
- from toolbars;
- from tool palettes;

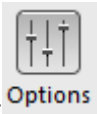
- from context menus called by clicking the right mouse button;
- from the command line;
- from the status bar;
- using hotkeys combinations;

For example, to open the **Options** dialog box:

- from the menu bar: **Tools – Options**;
  - on the **Settings** toolbar: the  **Options** button;
  - in the command line: **PREF** or **OPTIONS** command;
  - using hotkeys: **CTRL+9**.
- 
- from the ribbon –**Options** tab – **Customization** group -  **Options** ;
  - from nanoCAD button menu:  **Options**;
  - from the main menu: **Tools –  Options...**;
  - from the **Options**: bar, the  **Options** button;
  - from the command line: **OPTIONS**, **PREF** command;
  - from the context menu of the command line protocol: **Options...**;
  - using hotkeys combination: **CTRL+9**.

## Transparent Commands

Some commands can be launched while other commands are executed. Such commands are called transparent. Most of these commands are settings commands for display and document.

## Non-dialog Mode of Commands

It is possible to work with some commands in the mode of suppressing the display of dialog boxes – *non-dialog mode*, when all data are entered in the command line. For example, such mode allows you to use many commands from script files (scripts).

To run a command in the non-dialog mode, enter a hyphen (-) before the command name.

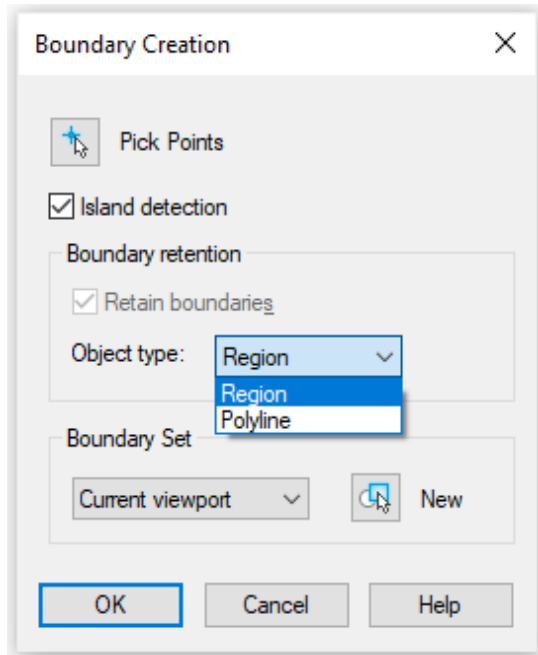

For example, **BOUNDARY** command from the command line opens the **Boundary Creation** dialog box.

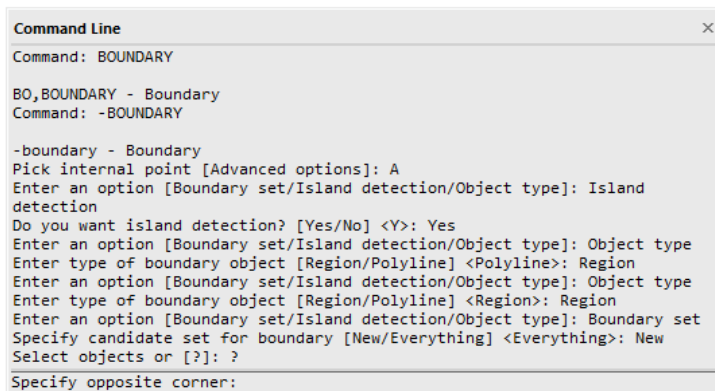

While the **-BOUNDARY** command will show a set of parameters and options in the command line.

The options displayed in the dialog box may differ slightly from those displayed on the command line.

You can view a list of commands for which you can use dialog suppression by typing a hyphen (-) in the command line.

## Command Recall

The last launched command can be started by pressing the **ENTER** or **SPACEBAR** buttons.

The last nine launched commands are available from the context menu (**Last commands**):

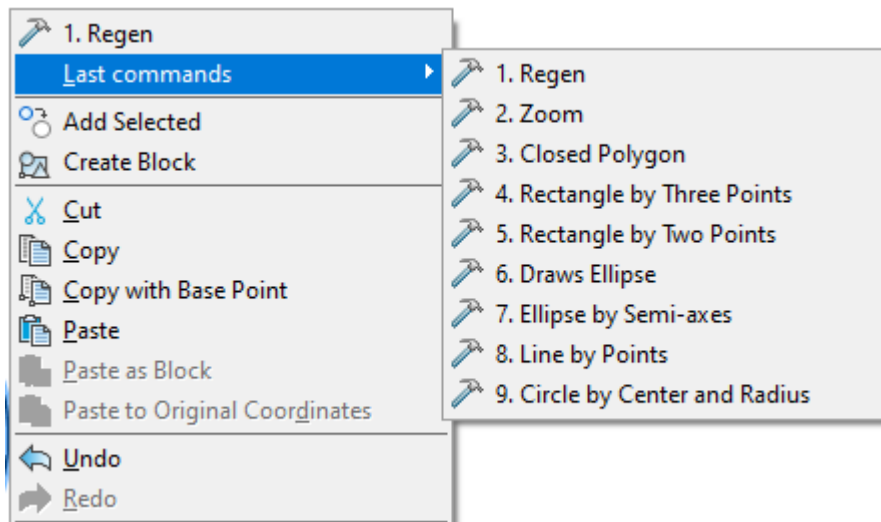

Last commands are shown in the command line.

Use **ARROW DOWN** and **ARROW UP** buttons to select one of the last commands and press **ENTER** to launch it.

## Undo-Redo Commands

nanoCAD creates protocols for all used commands and changes in the drawing, one or several commands can be undone to get to the previous step. Undone command can be launched again.

Cancellation and recall of commands can be made using the **Undo** and **Redo** commands.

Undo-redo options can be changed in the **Undo command settings** section of the **Options** dialog.

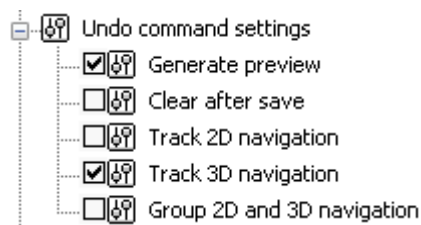

## Undo



Menu: **Edit** –  **Undo**



Toolbars: **Quick Access** and **Standard** – 



Hot keys: **CTRL+Z**



Command line: **UNDO, U, EDITUNDO**

The command to undo previous actions and operations.

Launch of the command from the menu by pressing a button, by hot keys or by entering **U** letter in the command line results in sequential cancellation of previous actions, one at each start.

Click on the arrow right of the button opens the list of performed actions:

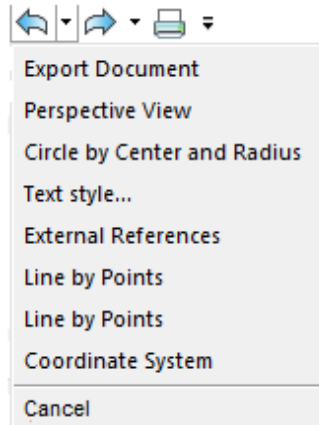

When you hover the cursor over a command item in the undo list, a preview of the scene that would appear after undoing actions up to the specified command will be displayed in the drawing workspace.

The preview is switched off by a flag **Undo command settings > Generate preview** in the **Options** dialog.

Entering **UNDO** in the command line allows you to expand the command options:

Enter the number of operations to undo or [Auto/Control/BEgin/End/Mark/Back] <1>:

Each launch of the **Undo** command in the command line is attended with the information on current settings: **Current status: Auto = On, Control = All.**

### Command options:

#### Number of operations to undo

Set the number of operations, which will be undone at once. Similar to repeated launch of **U** (**CTRL**+**Z**) command.

#### Auto

Group commands included in the macro command.

#### Control

Options of the **Undo** command

- **All** – turns on all the command options;
- **None** – completely turns off all cancellation commands;
- **One** – cancels only one action.

If **None** or **One** are enabled, **Auto**, **Begin** and **Mark** options are not available.

Launch of cancellation commands when **None** option is set, is attended with a prompt in the command line:

U command is disabled. Use UNDO command to turn it on

And suggestion to change option of undo control:

Enter an UNDO control option [All/None/One] <All>:

#### BEgin

#### End

Options allow you to combine a sequence of undo operations like a single operation. Commands performed between setting of **Begin** and **End** options will be cancelled simultaneously as a single action. By using **Begin** and **End** options, you can create several groups of performed operations, which will be undone in sequence.

After setting the **B**Egin option, the **Begin of command group** item will appear in the command list.

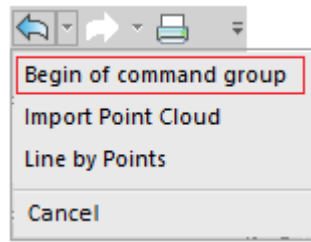

Next actions continue to be added in the undo list of operations one by one.

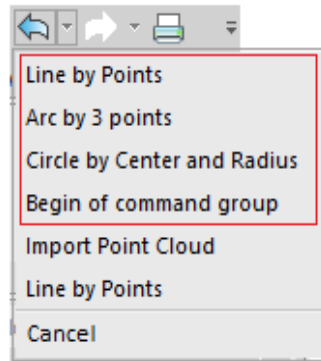

Till the **End** option is applied, the commands still can be cancelled by one. But no further than the **Begin of command group** item.

After the **End** option is applied, all actions in the undo list between the beginning and the end will collapse in a single group of commands.

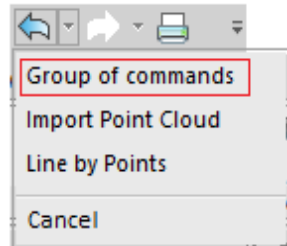

Now these actions can be cancelled only together.

Mark  
Back

Creating marks for a group cancellation of actions with help of **Back** option. You can set any number of marks. Start of **Undo** command with **Back** option cancels all actions back to the previous mark. If marks were not found, you will be prompted to delete all actions of the current work session.

The other cancellation methods, including **U** (**CTRL**+**Z**) command, do not take these marks into account in their work.

*Procedure of using Begin and End options:*

- Run the **Undo** command, select the **Begin** option.
- Perform the necessary actions - creating, editing objects, etc.
- Run the **Undo** command, select the **End** option,

Actions performed in the interval between entering **Begin** and **End**, are combined into one group. Cancellation is performed for the entire group of actions. By using **Begin** and **End** options you can create several groups of performed operations, which will be undone in sequence.

*Procedure of using Mark and Back options:*

- Run the **Undo** command, select the **Back** option.
- Perform the necessary actions - creating, editing objects, etc.
- Run the **Undo** command again, select the **Mark** option.



Thus, you can set an unlimited number of marks.

- Run the **Undo** command, select the **Back** option. Each performance of **Back** will cancel all operations before the previous mark.

The command parameters are configured in the **Undo command settings** section of the **Options** dialog (menu **Tools – Options**). In this section it is possible to control the display of preview of the result for each command step, add the undo list with 2D and 3D navigation commands, set to clear the list of all actions after a document is saved.

## Redo

 Menu: **Edit** –  **Redo**

 Toolbar: **Main** – 

 Hotkeys: **CTRL+Y**

 Command line: **REDO**

The command recovers all cancelled commands and operations. It becomes available after the **Undo** command is used.

## Settings of the Right Mouse Button

The settings of the right mouse button usage are specified in the **Right Button Usage** section of the **Options** dialog:

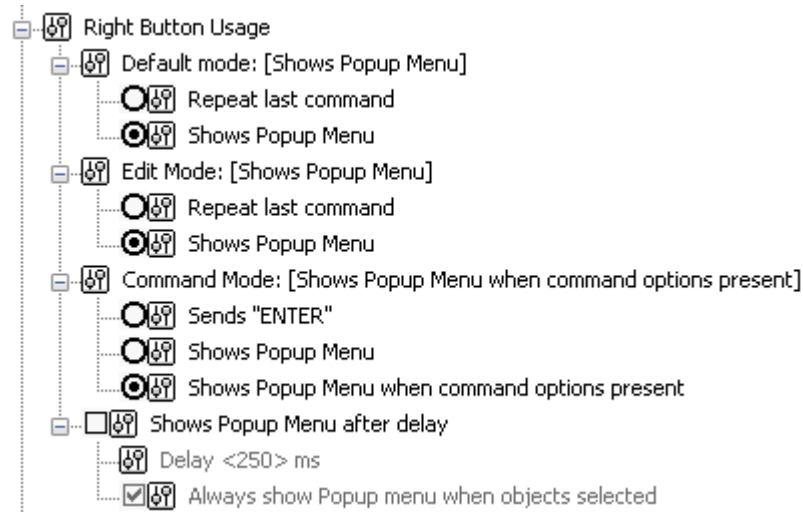

### Parameters:

#### Default Mode:

This section defines the behavior of the right mouse button in normal mode, when there are no objects selected and no running commands.

#### Repeat last command

Disables the standard right-click context menu. Simulates pressing the **ENTER** key, which causes the last command to run again.

#### Shows Popup Menu

Displays the standard context menu.



*Edit Mode:*

This section defines the behavior of the right mouse button in edit mode when objects are selected but there are no running commands.

**Repeat last command**

Disables the right-click context menu. Simulates pressing the **ENTER** key, which causes the last command to run again.

**Shows Popup menu**

Displays the context menu for editing selected objects.

*Command mode:*

This section defines the behavior of the right mouse button when it is pressed during a running command.

**Sends "ENTER"**

Disables the right-click context menu. Simulates pressing the **ENTER** key.

**Shows Popup menu**

Displays the context menu of the running command.

**Shows Popup menu when command options present**

Call the context menu of a command only if there are available options in the command line. If there are no options in the command line, pressing the right mouse button corresponds to pressing **ENTER**.

*Shows Popup menu after delay:*

Enables the mode which considers the duration of right button holding:

- short click – repetition of command or simulating pressing the **ENTER** key, according to the mode,
- long hold – opens the context menu.

**Delay <250> ms**

Specifies, in milliseconds, the duration of right button holding to open the context menu. By default, the value is 250 Ms.

**Always show Popup menu when objects selected**

If enabled, then if there is one or more objects in the selection, pressing the right mouse button always brings up the context menu, regardless of the duration of the press.

## Status Bar





There are interface elements in the *status bar*:

*Current coordinates of the cursor:*















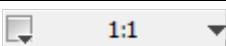

58.1962,403.4737,0.0000	Display modes: <ul style="list-style-type: none"> <li>dynamic display of cursor absolute coordinates when the cursor is moving,</li> <li>display of relative distance (distance&lt;angle) when the cursor is moving. Switching to the relative distance mode is made automatically when specifying two or more points is required.</li> </ul>
104.9102 < 29	





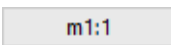

*Buttons to switch on/off modes:*

SNAP	<a href="#">Snap</a> to grid ( <b>F9</b> ).
GRID	Show grid ( <b>F7</b> , <b>CTRL+G</b> ).
OSNAP	Object snap ( <b>F3</b> ).
OTRACK	Object tracking ( <b>F11</b> ).

	Polar tracking ( <b>F10</b> ).
	Ortho mode ( <b>F8</b> ).
	<a href="#">Dynamic input</a> ( <b>F12</b> ).
	Show Linewidth.
	Show Hatch. Displays hatches, shape fills, and wide polylines. If the Show Hatch mode is turned off, then wide polylines, filled polygons, gradient fills and hatches are displayed as outlines, that increases the screen rendering speed.

### Buttons to manage the drawing area:

	Multi-function button to switch between model space and paper space: <ul style="list-style-type: none"> <li>when working in model space, switches to the space of the last active layout.</li> <li>when working in paper space, switches to model space of the viewport.</li> </ul>
	Button to <a href="#">lock the scale</a> of the selected viewport in paper space. Viewport lock is used to keep the previously set viewport scale unchanged (so that zooming inside the viewport does not affect the viewport scale). The button can be in four states: <ul style="list-style-type: none"> <li> No viewports selected.</li> <li> The scale of the selected viewport is available for changing (unlocked).</li> <li> The scale of the selected viewport is not available for change (locked).</li> <li> Several viewports with different locking parameters are selected in paper space.</li> </ul>
	Sets the scale for the selected viewport in paper space. Not available when the viewport is locked  .
	Button to control the preview state of drawing objects in a selection set.
	Controls visibility of objects by <a href="#">isolating or hiding</a> a selection set.
	Dynamic UCS.
	Enables/disables selection for objects on locked layers.
	Button to set <a href="#">symbol scale and measurement scale</a> of an objects.
	CAD standards: configuring standards, checking drawings for standards violations, notification of standards violation.
	<a href="#">Pan</a> .
	Zoom.

	<a href="#">Zoom All.</a>
	<a href="#">Zoom Window.</a>
	<a href="#">3D Orbit.</a>
	Button to start drawing regeneration.
	<p>Button to lock/unlock interface elements to prevent accidental movement:</p> <ul style="list-style-type: none"> <li>• Docked toolbars;</li> <li>• Floating toolbars;</li> <li>• Docked windows;</li> <li>• Floating windows;</li> <li>• All locked;</li> <li>• All unlocked.</li> </ul> <p>For temporary unlocking – press and hold the <b>CTRL</b> key.</p>
	<p>Button to indicate the presence of external reference in a drawing.</p> <p>When rolling over the button, a pop-up window appears on the absence or presence of external references.</p> <p>The button's context menu contains the commands:</p> <p><b>External references</b> – opening the function bar;</p> <p><b>Refresh external references.</b></p>
	Button to switch on/off full screen mode.

To switch the status bar on/off, use the **SHOWSTATUSBAR** command from the **View** -  **Status bar** menu or hotkeys **ALT+S**.

## Managing Elements of the Status Bar

Use the **Status Bar Configuration** menu to set elements of the Status bar:

Status Bar Configuration			
<input checked="" type="checkbox"/>	.	1315.1182,-131.4233,0.0000	
<input checked="" type="checkbox"/>	SNAP	SNAP	
<input checked="" type="checkbox"/>	GRID	GRID	
<input checked="" type="checkbox"/>	OSNAP	OSNAP	
<input checked="" type="checkbox"/>	OTRACK	OTRACK	
<input checked="" type="checkbox"/>	POLAR	POLAR	
<input checked="" type="checkbox"/>	ORTHO	ORTHO	
<input checked="" type="checkbox"/>	DYN	DYN	
<input checked="" type="checkbox"/>	SW	SW	
<input checked="" type="checkbox"/>	SH	SH	
<input checked="" type="checkbox"/>			ToggleModelPaperSpace2
<input checked="" type="checkbox"/>			ToggleViewPortBlock
<input checked="" type="checkbox"/>			ToggleViewPortScale
<input checked="" type="checkbox"/>			ToggleSelectionPreview
<input checked="" type="checkbox"/>			ToggleIsolate
<input checked="" type="checkbox"/>		Selection from locked layers	Selection from locked layers
<input checked="" type="checkbox"/>		Dynamic UCS	Dynamic UCS
<input checked="" type="checkbox"/>		Scale	
<input checked="" type="checkbox"/>		PAN	PAN
<input checked="" type="checkbox"/>		Zoom	Zoom
<input checked="" type="checkbox"/>		Zoom All	Zoom All
<input checked="" type="checkbox"/>		Zoom Window	Zoom Window
<input checked="" type="checkbox"/>		Virtual Trackball	Virtual Trackball
<input checked="" type="checkbox"/>		Regen	Regen
<input checked="" type="checkbox"/>		Lock/Unlock position	
<input checked="" type="checkbox"/>		FULLSCREEN	FULLSCREEN

**To open the context menu:**

1. Right button click on the Status bar.
2. Select/deselect the required elements in the context menu.

## Restore UI State

 Ribbon: **Manage – Customization** >  **Restore UI State**

 Menu: **Tools – Customize** >  **Restore UI State**

 Command line: **RESTOREUISTATE**

The command allows you to reset the display settings and arrangement of toolbars and functional panels after restarting the program.

It resets the display and layout of the following user interface elements to their original state:

- display and location of functional panels (including command line panels),
- display and arrangement of toolbars (their content will not change),
- display and arrangement of tabs and groups of the ribbon (their contents will not change), as well as the display mode of the ribbon: compact view / visibility,
- size and position of the main window,
- display of the status bar and its settings.

This command is convenient to use to restore the display of the [command line](#) panel, if it does not appear automatically after starting any command.

## Managing Interface Elements

To change the location of interface elements, drag their titles.

### To change location:

1. Click on an element's title and drag it to an area of the window where you want to attach the element. The icon appears in the center of the window, showing the place of attachment in the window.
2. Holding the left button, place the cursor over one of the pictograms.



The central pictogram is used to attach the object as a tab, others attach to the sides of the window.

The new location of the element is highlighted blue.

If you are satisfied with the new location, release the button.

The attached element can be made into a pop-up tab. Select the pin in the element's title:



For some elements, the context menu is available with various ways of attachment:

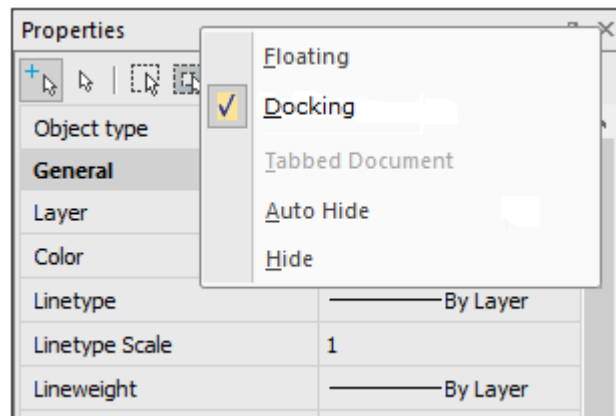

## Application Look

nanoCAD contains a set of visual themes. You can change visual style in **Application Look** section in the **Options** dialog.

To preview selected style without closing dialog – use **Apply** button.

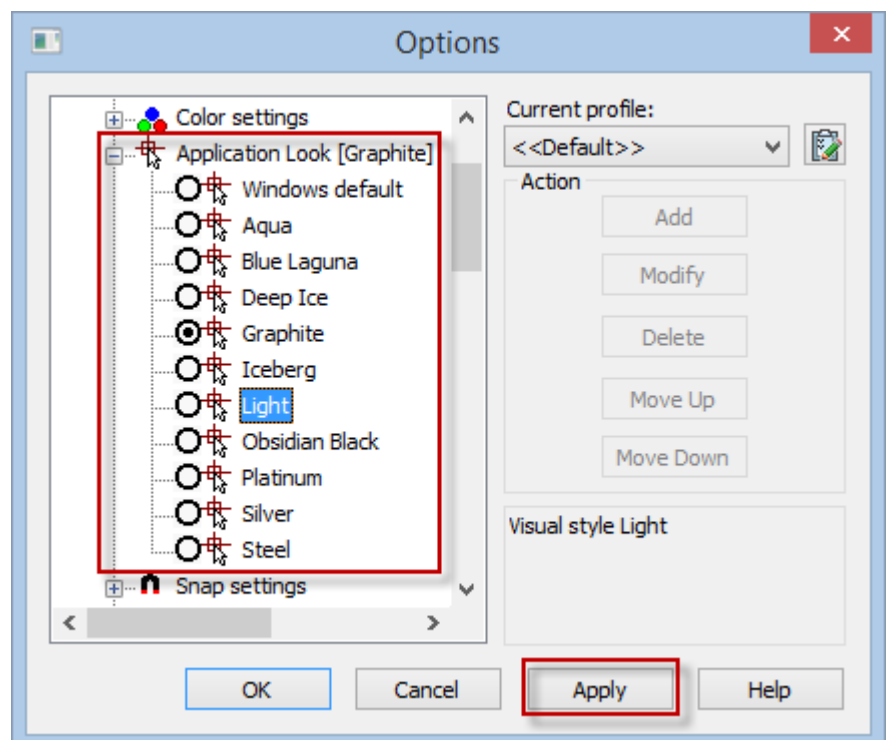

## Color Themes

In addition to the possibility of the workplace complete reorganization to the user needs, nanoCAD contains a set of color themes for the interface design. You can change the color theme in the **Options** dialog box, the **Application look** item.

To apply the selected theme without closing the dialog box, click the **Apply** button in the bottom part of the **Options** dialog.

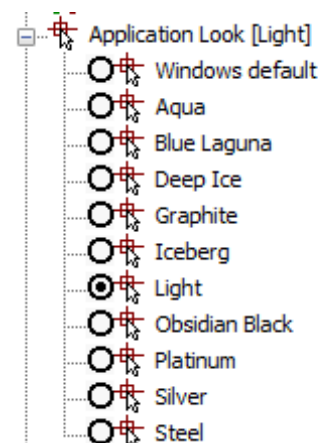

## WORKING WITH DOCUMENTS

nanoCAD allows documents to be saved with **\*.dwg** (drawing format), **\*.dwt** (template format) and **\*.dxf** (graphic data exchange format) extensions. There is support of file formats created in the following AutoCAD versions:

- AutoCAD 2018-2019/LT2018-2019
- AutoCAD 2013-2017/LT2013-2017
- AutoCAD 2010-2012/LT2010-2012
- AutoCAD 2007-2009/LT2007-2009
- AutoCAD 2004-2006/LT2004-2006
- AutoCAD 2000-2002/LT2000-2002
- AutoCAD R14/LT98/ LT97
- AutoCAD R13/LT95
- AutoCAD R11
- In the **nanoCAD** button menu and on the **Quick access** toolbar:

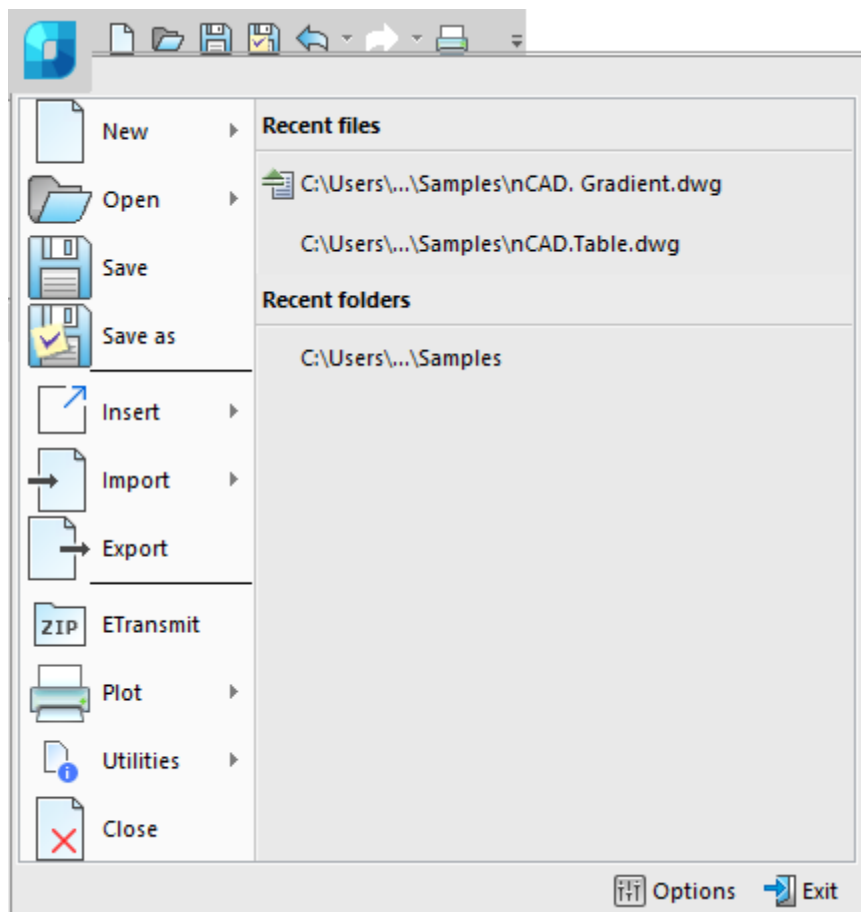



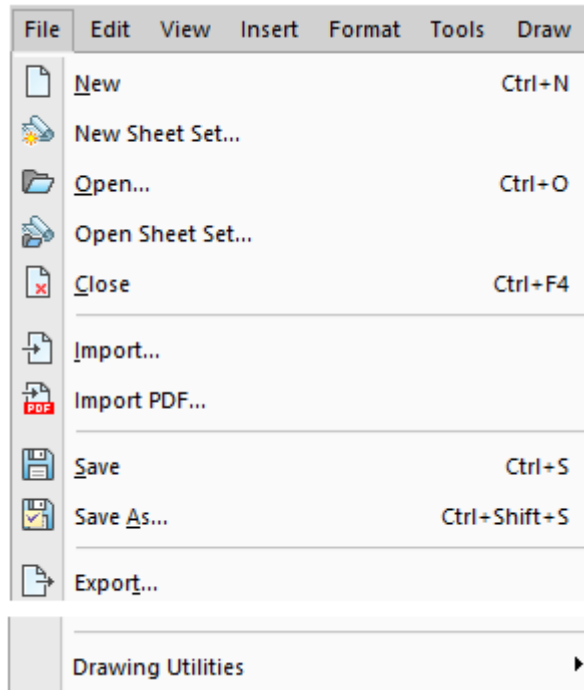





Commands to work with documents are in the **File** menu:



and on the **Main** toolbar:



## Creation of New Document

-  nanoCAD button -  **New**
-  Menu: **File** -  **New Document**
-  Toolbar: **Main** - 
-  Hotkeys: **CTRL+N**
-  Command line: **NEW, NEWDOCUMENT**

A new document, created at the first launch, has the name *Untitled0*. All subsequent documents have the names *Untitled1*, *Untitled2* etc. Documents which have been modified and not saved have a star symbol (\*):











## Template Usage

To create a new document, you can use a *template* (files with \*.dwt extension). The *template* is a drawing used for the creation of new drawings and contains some base settings (type and

accuracy of units, drawing limits, settings of **SNAP** and **GRID** modes; managing of layers; dimension and text styles; types and weights of lines etc.) and graphic objects (main titles, borders and logos).

Document template samples are in the system folder nanoCAD **Templates**:

-  Default
-  nanoCAD\_EarthWork\_metric
-  nCad\_ESKD
-  nCad\_ESKD\_izometr
-  nCad\_SPDS
-  nCad\_SPDS\_izometr
-  Sample\_ESKD
-  Sample\_SPDS

Template files having *izometr* in the name, contain dimension styles settings to place dimensions in isometry.

Changes in a drawing created using a template are not applied to the template.

**NOTE:** You can create a template not only for new documents but also for imported documents.

Templates are managed in the **Template Usage** section of the **Options** dialog:

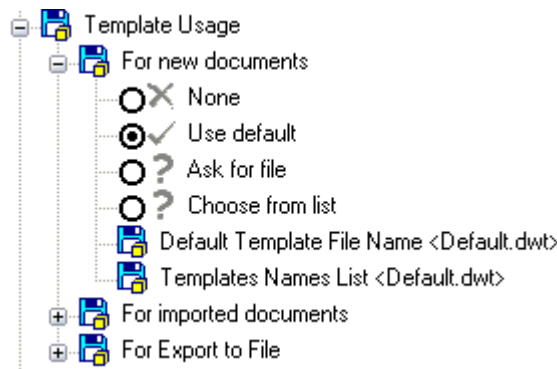

In the **For new documents** subsection you can select:

- |                                   |   |
|-----------------------------------|---|
| <b>None</b>                       | Prevents the use of a template for new documents.                                   |
| <b>Use default</b>                | Uses the file specified in <b>Default Template File Name</b> parameter.             |
| <b>Ask for file</b>               | Opens the dialog box <b>Open Document Template File</b> .                           |
| <b>Choose from list</b>           | Opens the <b>Choose Template</b> dialog box.  |
| <b>Default Template File Name</b> | Sets the default template file name.  |
| <b>Templates Names List</b>       | Specifies a list of templates if the <b>Choose from list</b> parameter is selected. |

**To specify list of templates:**

1. Click twice on the **Templates Names List**.
2. Click the  button.
3. In the **Open** dialog box select template files.
4. Click **Open**.



**NOTE:** You can specify a list of templates from different folders. Select manually or using the clipbook paths to templates and templates' names, separating them with semicolon. Spaces after semicolon are not allowed. Semicolon should be also placed at the end of the list.

## Creating a New Document by the Specified Template



Command line: **QNEW**

The command allows you to create a drawing based on a default template file, or a template specified in the command line.

## Opening a Document



**nanoCAD button - Open**



Menu: **File - Open...**



Toolbar: **Main- Open**



Hotkeys: **CTRL+O**



Command line: **OPEN, OPENDOCUMENT**

Command opens the dialog to find and open the desired file.

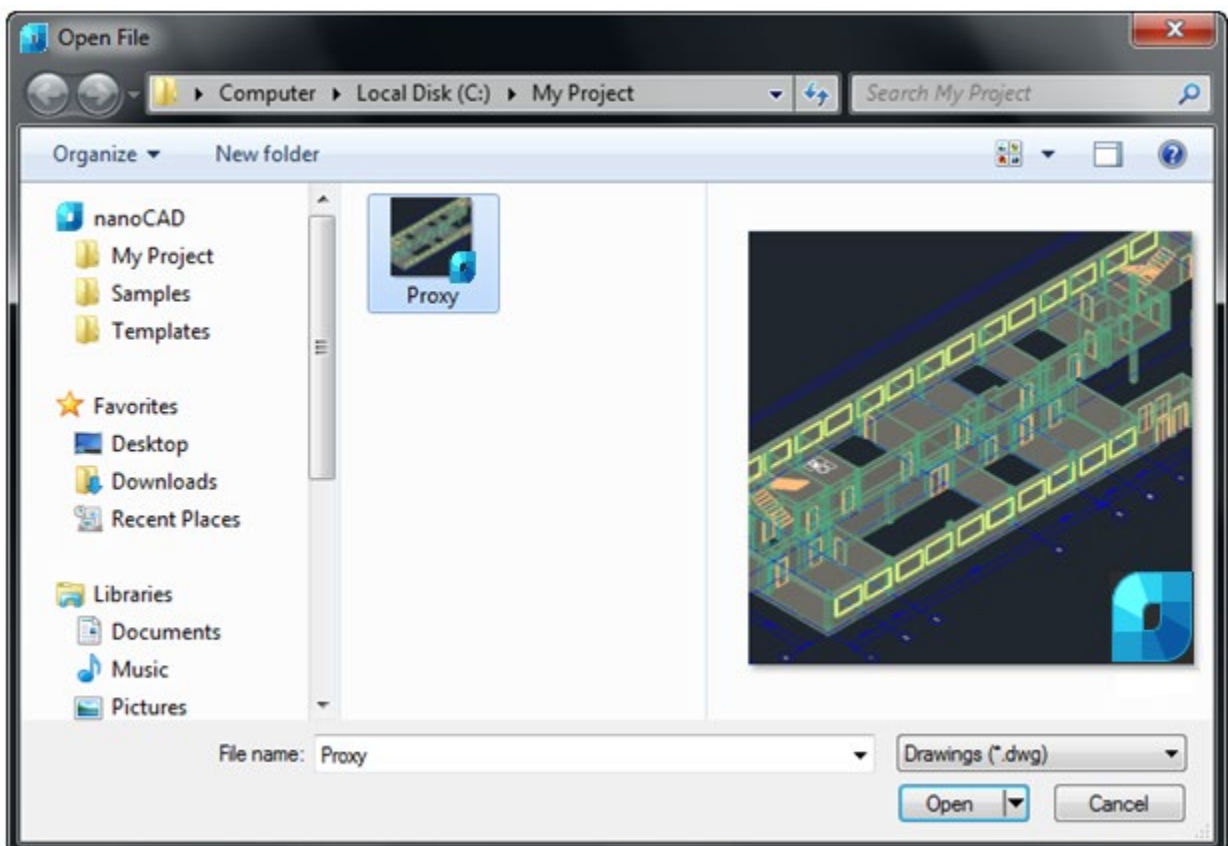

Note! Navigation pane in **nanoCAD** list displays only those folders that are specified in **Standard directories** section of the **Options** dialog:

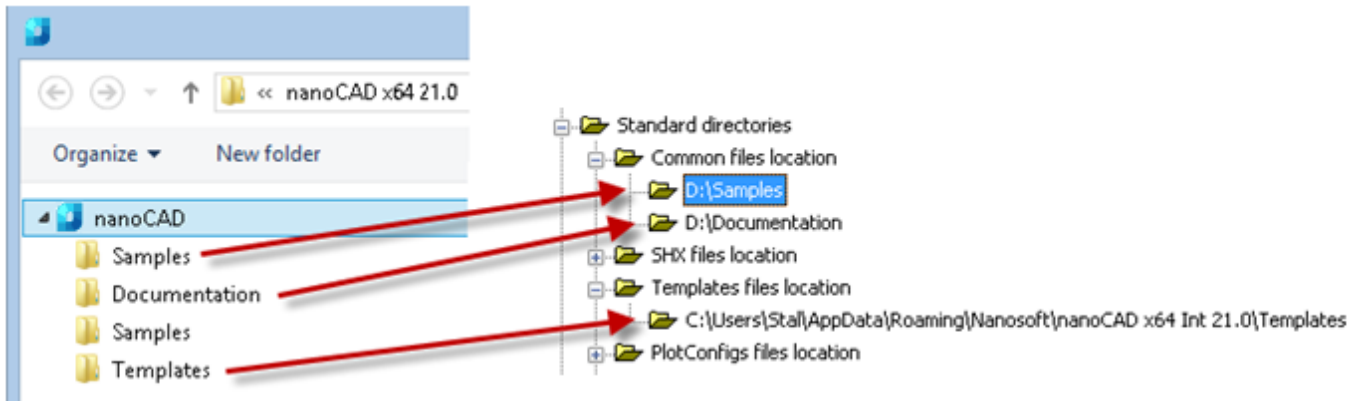

To open a document, you can drag it into the working area of nanoCAD.

It is available to open document for reading or open as copy:

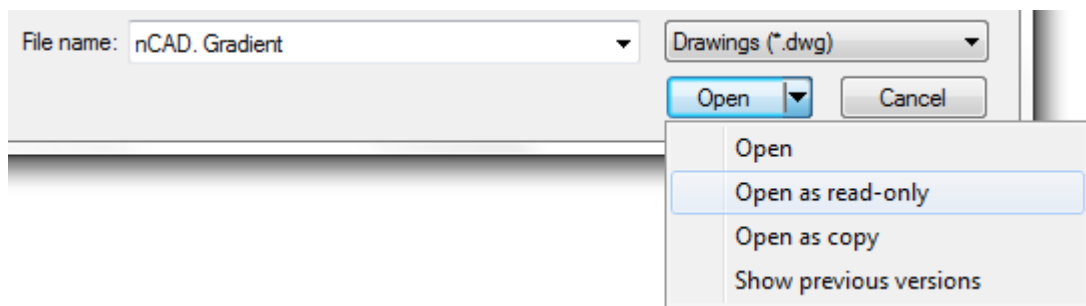

**Open as read-only** – Open the document for reading without editing.

**Open as copy** – Open the copy of document. Prefix **Copy (N)** added to the file name. **N** is number of copies.

**NOTE:** Assign new name for copied and read-only files to save changes.

There are two lists to quick access to the last opened files and folders in **nanoCAD button** and the **File** menu:

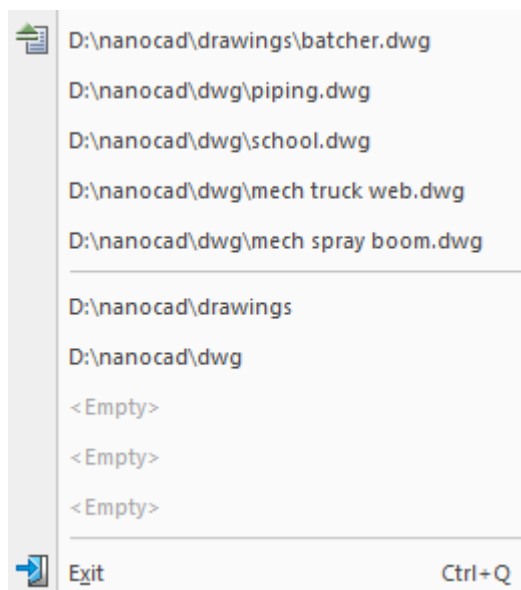

The last opened file has the  icon.

When opening a document, it checks to see if annotative scales and empty entries in the sort table need to be cleared.



## Documents Protection when Sharing

nanoCAD has mechanism protecting file against losing information when the file is opened by several users.

A message appears when user opens file that is open by another user or when file is read-only:

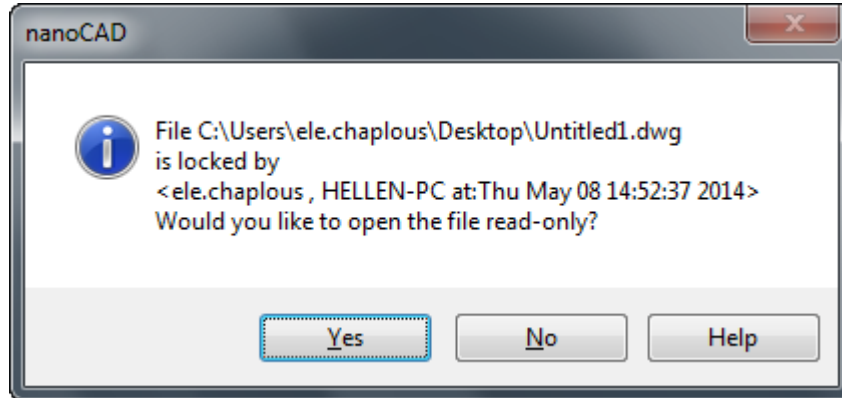

or

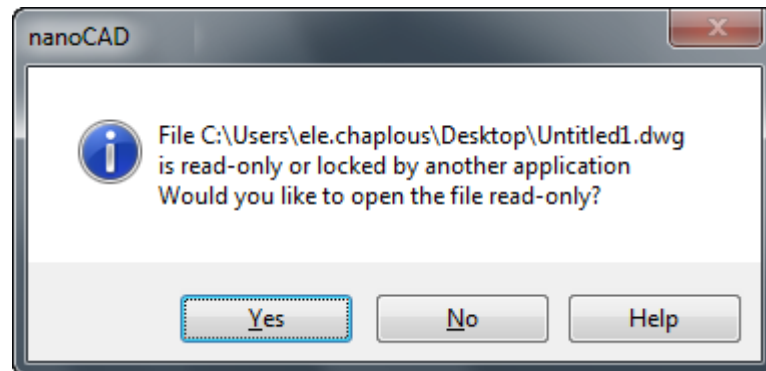

If the document is read-only, inscription **Read Only** appears in the document tab:

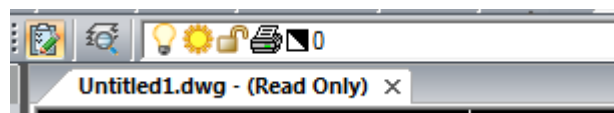

Only user who opened the file first can save the under the same name. Others receive message even if the first user closes the file:

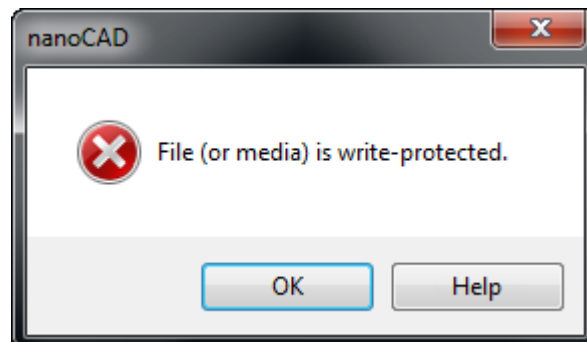

Other users can save the file after reopen.

## Working with Document Tabs

When many documents are opened, every document is opened in a separate window with a tab in the top part of the working area. To switch between them, select the tab or click the **Active files** button in the top right corner of the document window:

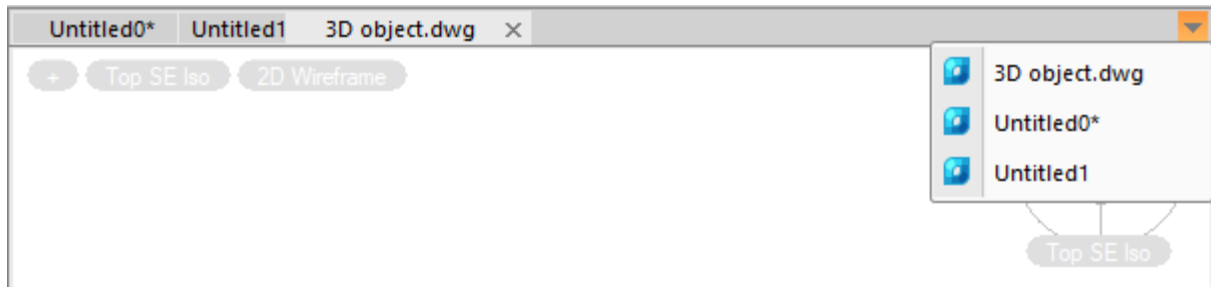

If you place the cursor over the document tab, a tooltip with the information about file location is shown:

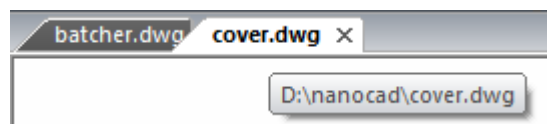

The context menu permits the selection of display options for the documents:

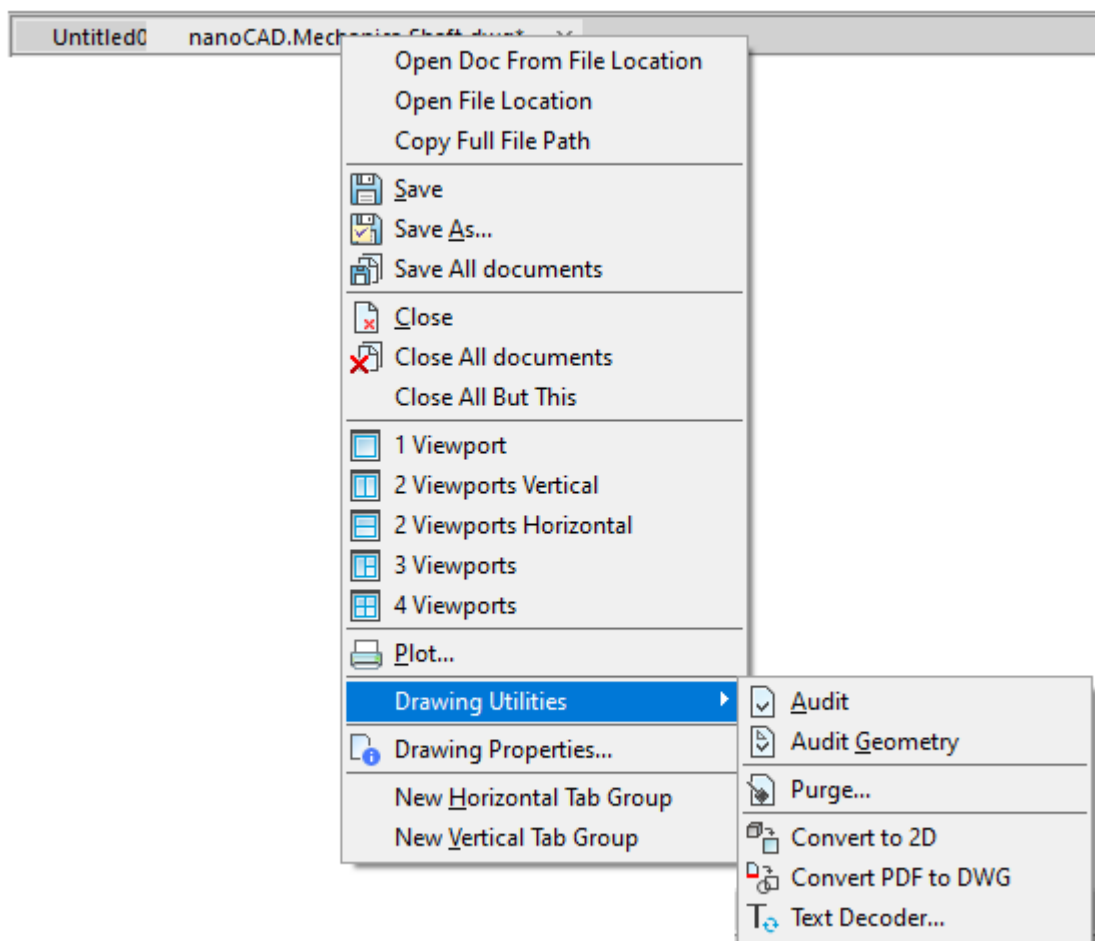

### Commands of the context menu:

#### Open Doc from File Location

Starts the **OPEN** command with passage to the folder from which the current document was loaded to search for and open the next file (**OPENFOLDERCURDWG** command).

<b>Open File Location</b>	Passage to the location where the file is stored in Windows Explorer ( <b>OPENFOLDERCURDWGWITHEXPLORER</b> command).
<b>Copy Full File Path</b>	Copies full path of file to clipboard( <b>COPYFULLPATH</b> command).
<b>Save</b>	Saves a document with the previous name.
<b>Save As...</b>	Saves a document with a new name.
<b>Save All documents</b>	Saves all opened documents( <b>SAVEALL</b> command).
<b>Close</b>	Closes a document.
<b>Close All documents</b>	Closes all opened documents( <b>CLOSEALL</b> command).
<b>Close All But This</b>	Closes all opened documents except the current( <b>CLOSEALLBUTTHIS</b> command).
<b>Plot</b>	Prints a document.
<b>1 Viewport</b>	<b>In model:</b> Representation of the document tab window in the 1st viewport. <b>In paper:</b> Creating a viewport that fits within the printable area of the layout.
<b>2 Viewports Vertical</b>	<b>In model:</b> Dividing the document tab window into 2 viewports vertically. <b>In paper:</b> Creating 2 identical vertical viewports fit into the print area of the layout.
<b>2 Viewports Horizontal</b>	<b>In model:</b> Dividing the document tab window into 2 viewports horizontally. <b>In paper:</b> Creating 2 identical horizontal viewports fit into the print area of the layout.
<b>3 Viewports</b>	<b>In model:</b> Dividing the document tab window into 3 viewports. <b>In paper:</b> Creating 3 viewports fit into the print area of the layout. The command line prompts you to select a configuration for the layout of viewports: Enter an option [ <u>H</u> orizontal/ <u>V</u> ertical/ <u>L</u> eft/ <u>R</u> ight/ <u>T</u> op/ <u>B</u> ottom]<Right>
<b>4 Viewports</b>	<b>In model:</b> Dividing the document tab window into 4 viewports. <b>In paper:</b> Creating 4 identical viewports fit into the print area of the layout.
<b>Drawing Utilities</b>	Utilities to check, clean and correct a document.
<b>Drawing Properties</b>	Information about the document.
<b>Float Window</b>	Sets the document window to a floating state.
<b>New Horizontal Tab Group</b>	Horizontal display of a tab in the working area.

## New Vertical Tab Group

Vertical display of a tab in the working area.

You can change the location of tabs by dragging them in one document window or into other windows.

If you release the left button when dragging a tab over a document working area, the context menu with tab display options will be shown:

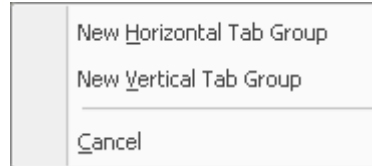

## Floating Document Window



Context menu of the document tab:  **Float Window**



Command line: **FLOAT\_WINDOW**

The **Float Window** command transfers a current document tab in a floating window state.

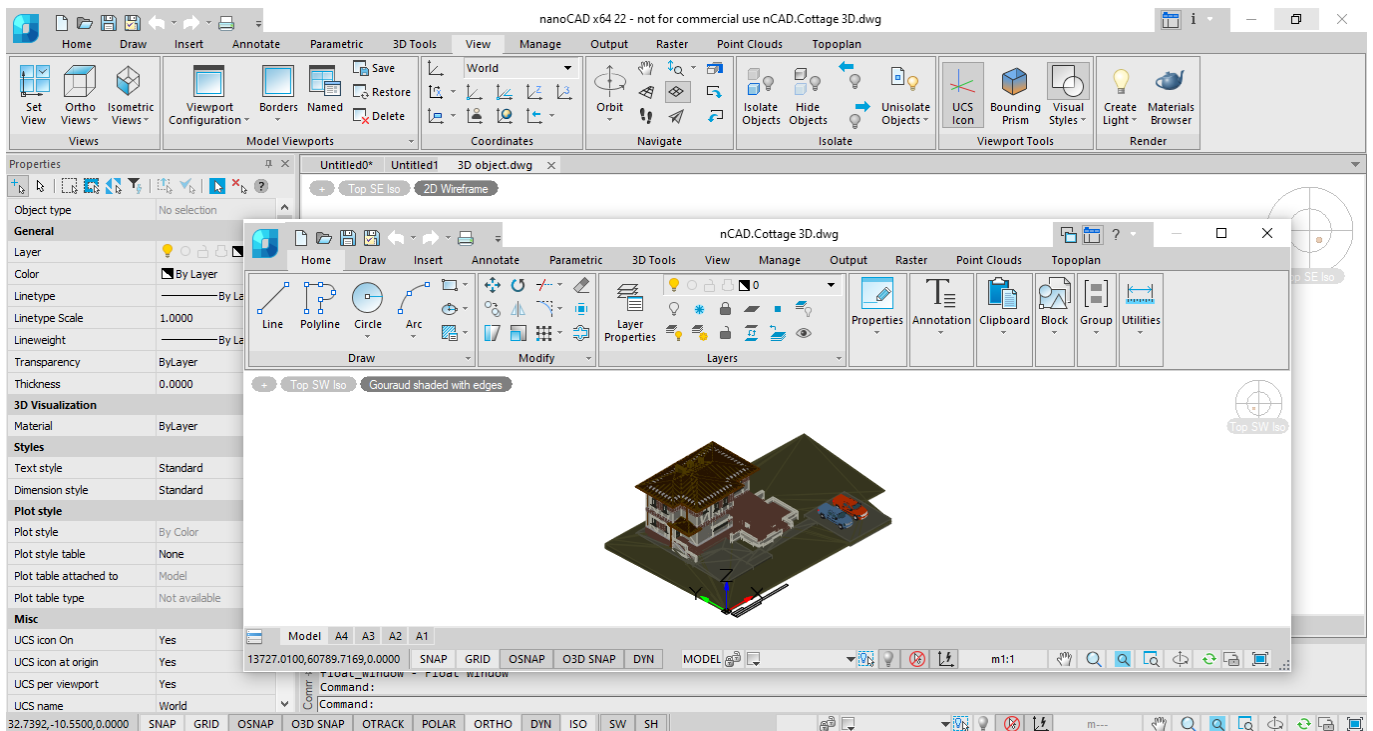

A document's floating window is always in the foreground. It does not contain a command line, it cannot contain other document tabs. Functional panels cannot be attached to it.

In the **Options** dialog you can specify whether the floating window should contain the ribbon, menu or status bar.

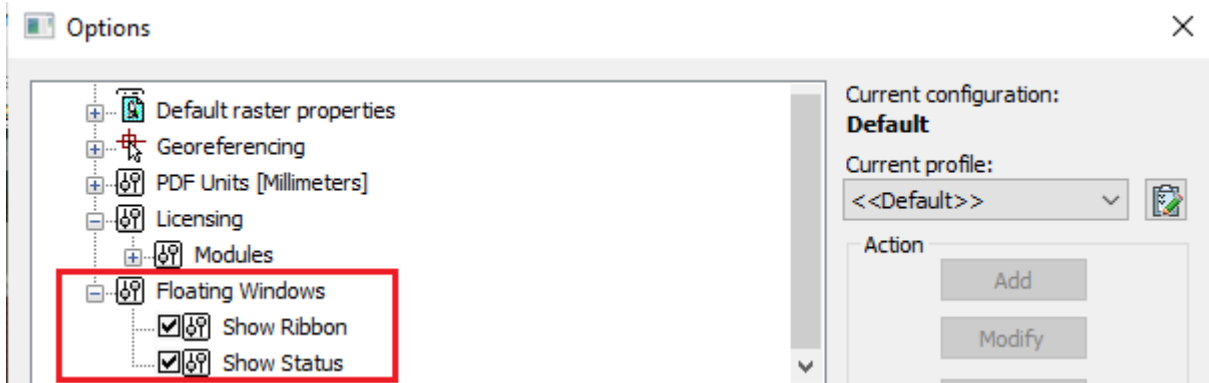

## Docked Document Window

 Context menu of the document tab:  **Dock Window**

 Command line: **DOCK\_WINDOW**

The **Dock Window** command attaches the floating document window back to the main window as a document tab.

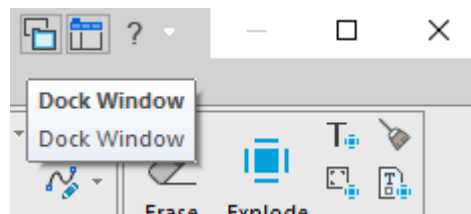

## Drawing Properties

Edit general information, keywords, custom properties of the drawing.

 nanoCAD button – Utilities –  **DWG Properties**

 Menu: **File** –  **Drawing properties**

 Document tab context menu:  **Drawing properties**

 Command line: **DWGPROPS**

The command allows you to obtain information about the drawing and enter identification data.

The dialog box called by the command displays general information about the drawing: name, size, creation date, modification date and other properties:



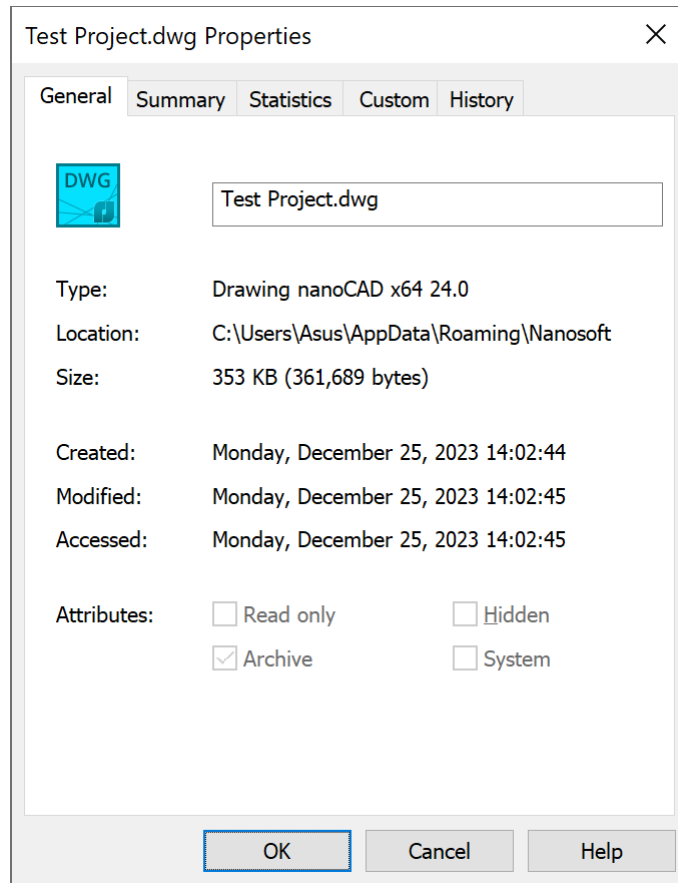

**General** tab shows file name, location, size, creation, modification and access date and time.

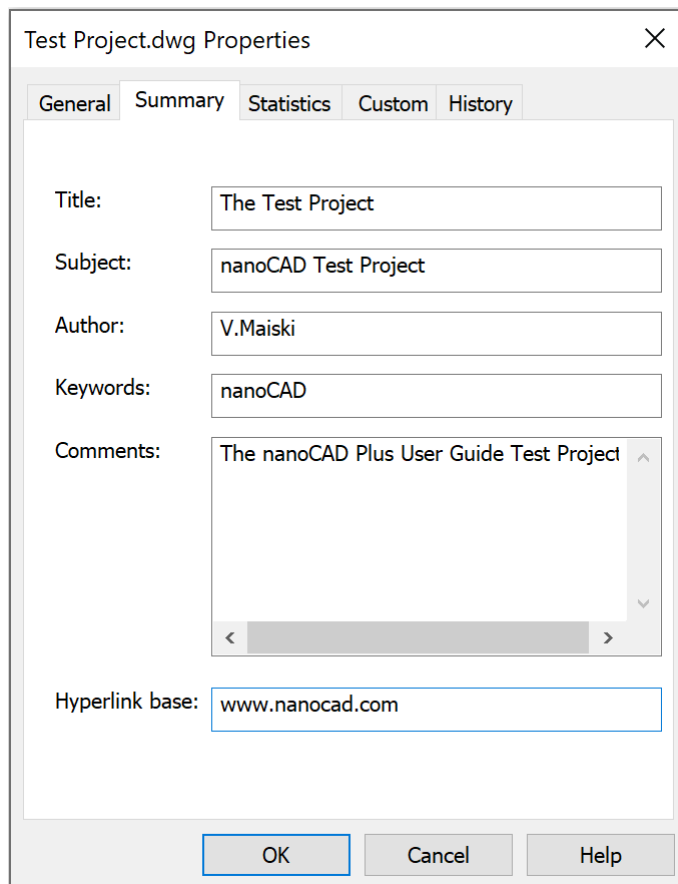

The **General** tab displays the following parameters: file name, type; location, size, time the file was created, modified and last opened.

The **Attributes** section shows file attributes set at the systemic level:

- **Read only** – the file is protected from rereading;
- **Archive** – the file is subject to archiving (used when selecting files for backup);
- **Hidden** – not shown in lists and can be opened only by entering the name directly.
- **System** – the file is a system one.

On the **Document** tab you can enter the information about the following parameters:

In the **Summary** tab:

<b>Title</b>	Document Title.
<b>Subject</b>	Document subject
<b>Author</b>	Document author.
<b>Keywords</b>	Keywords for search.
<b>Comments</b>	Comments.
<b>Hyperlink base</b>	Hyperlink base for all relative hyperlink in drawing.

#### Statistics tab

The **Statistics** tab displays the drawing data: time it was created and modified, information about modification author, revision number and total editing time.

The **Custom** tab sets additional properties of the current drawing. The properties set on this tab can be used when inserting fields. They are displayed in the **Field** dialog box (**Custom properties** – List of the **Add custom property** section).

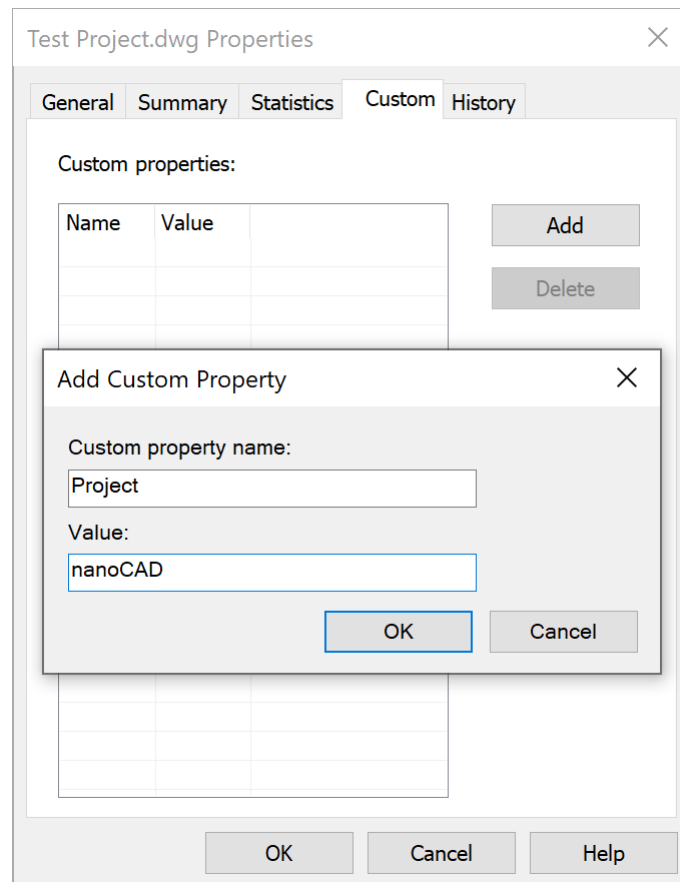

#### To create new custom property:

1. Press **Add** button.
2. Enter **Custom property name**.











3. Enter property **Value**.
4. Press **OK**.

The name and the value are displayed in the **Custom properties** list.

To remove property – select it and press **Delete** button.

**NOTE:** If the removed custom property is used in any of the fields, when the fields are updated, that field will display the latest value.

## Closing a Document

-  nanoCAD button –  **Close**
-  Menu: **File** –  **Close**
-   button on the document's window
-  Document tab context menu:  **Close**
-  Hotkeys: **CTRL+F4**
-  Command line: **CLOSE**

When closing an existing document, you should save the changes to it; the document is saved with its name.

When closing a new document, the program offers to save changes and opens the **Save Document File** dialog box.

To close all open drawings, you can use the **Close All** command (CA, CLOSEALL). For each drawing that has unsaved changes, you should confirm saving.





## Saving a Document

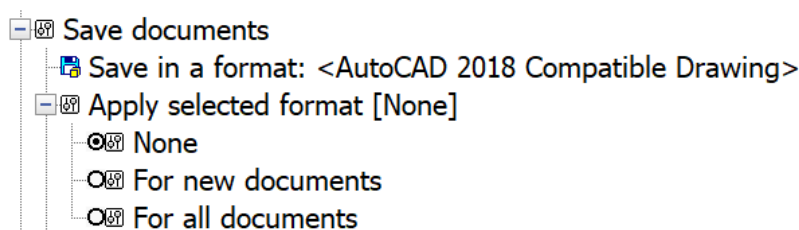

Documents can be saved in the **\*.dwg** drawing format, in the **\*.dxf** graphic data exchange format and in the **\*.dwt** template format. **Save**, **Save As** and **WBLOCK** commands are used.

The use of file formats when saving documents using the **Save** and **Save as** commands is selected and configured in the **Save documents** section of the **Options** dialog (menu **Manage > Options**):



### Saving of an existing document

-  nanoCAD button –  **Save**
-  Menu: **File** –  **Save**

 Toolbar: **Main** – 

 Hotkeys: **CTRL+S**

 Command line: **SAVE, BS, SAVEDOCUMENT**

The command saves a document with its name.

### *Saving a new document*

The **Save** command opens the **Save Document File** dialog box, where you can specify a path for a document and change the default file name:

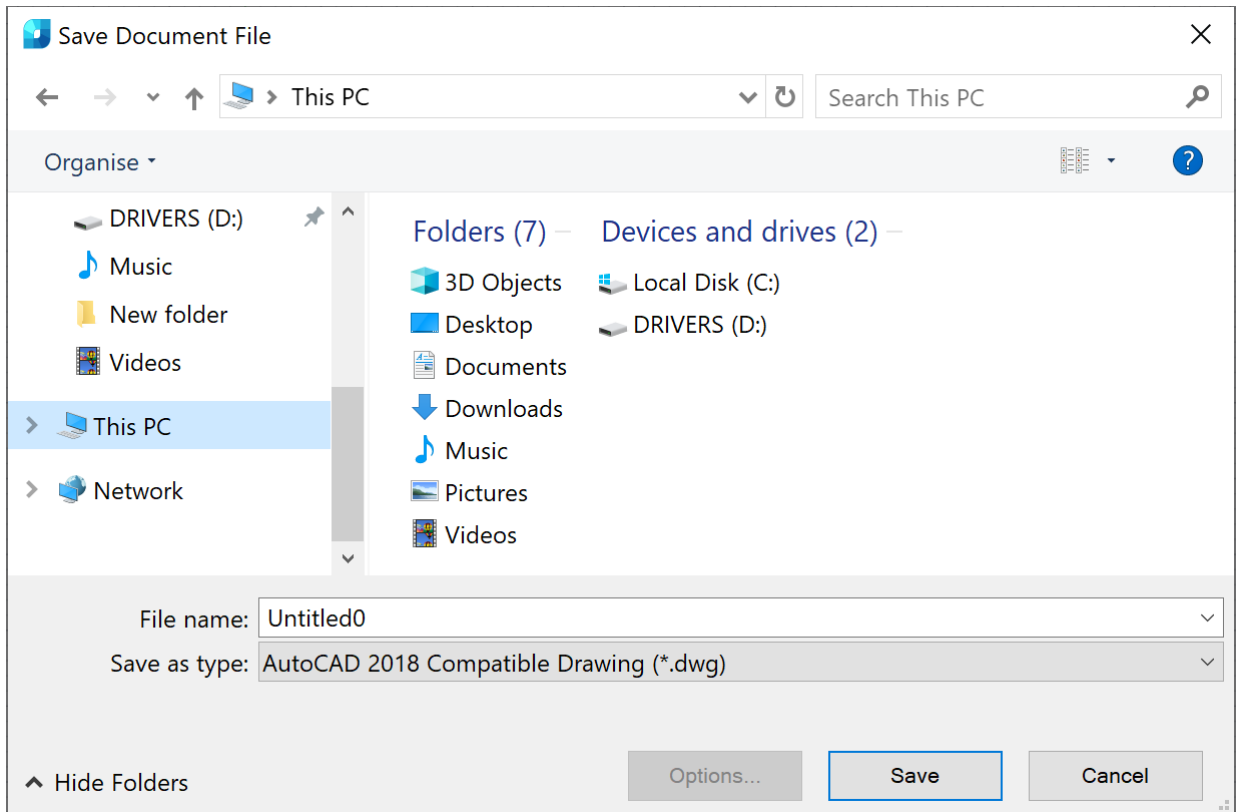

**NOTE:** Navigation pane in **nanoCAD** list displays only those folders that are specified in **Common files location** section of the **Options** dialog:

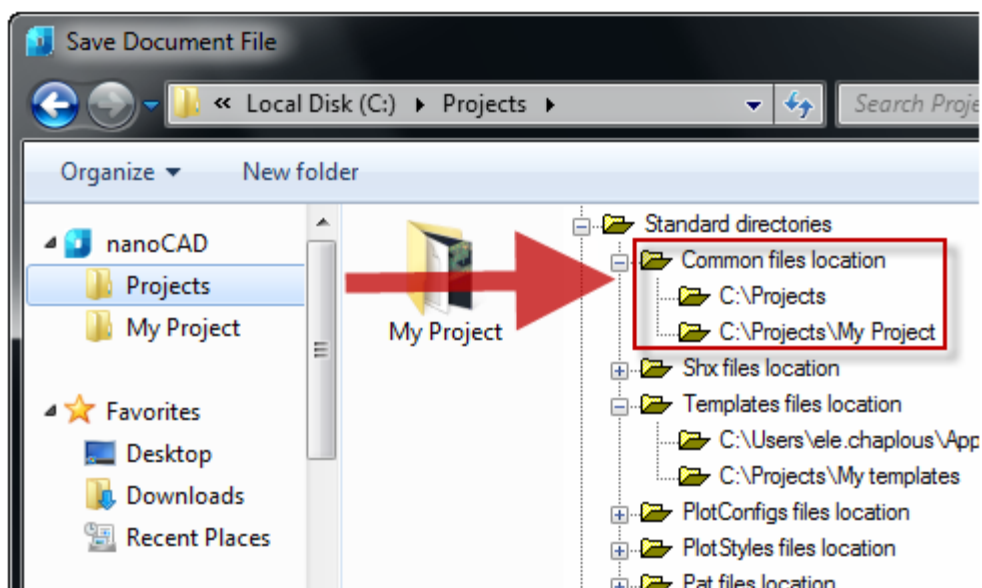

### To save a document:

1. Specify the path to the file in the **Folder** drop-down list;
2. Type the name in the **File name** field;
3. Select the format in the **File type** field;
4. Select the **Save** button.

Saving the file will be done without specifying the path and file name in the future.

**NOTE:** Format, specified in the **File type** field, is also used as default to save all documents with **Save**, **Save As** and **WBLOCK** commands.

To save all open drawings, you can use the **Save All** command (SA, SAVEALL). If the drawing is not named, you will be prompted for a file name when you run the command.

## Saving a Document with Another Name

 nanoCAD button –  **Save as**

 Menu: **File** –  **Save As**

 Hotkeys: **CTRL+SHIFT+S**

 Command line: **SAVEAS, SAVEASDOCUMENT**

Every time you select the **Save As** command, nanoCAD will offer to specify a path to the file and/or change the file name in the **Save Document File** dialog. The selected path and entered file name are set by default, and when the **Save** command is used, the file will be saved with the path and name specified earlier.

**NOTE:** **Navigation** pane in the nanoCAD list displays only those folders that are specified in **Common files location** section of the **Options** dialog

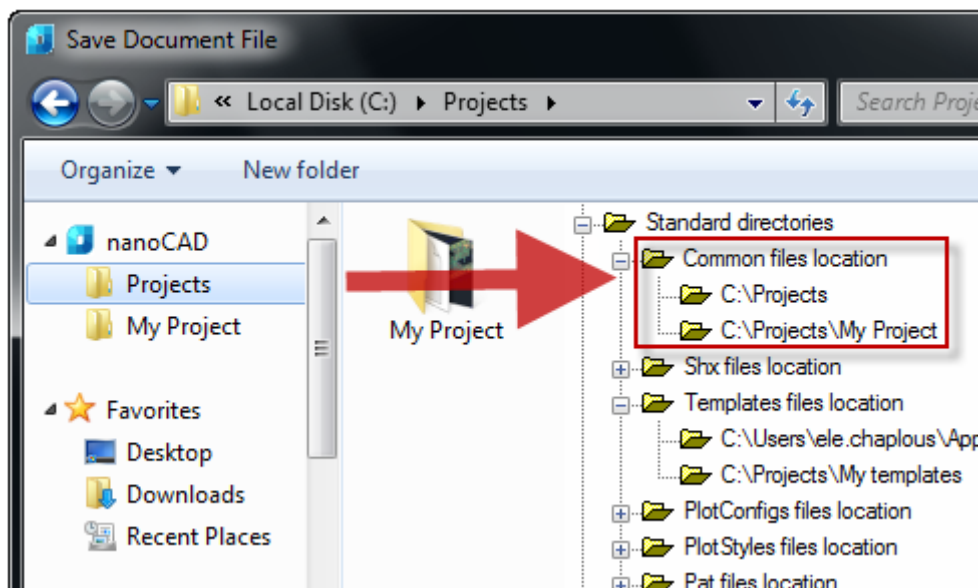
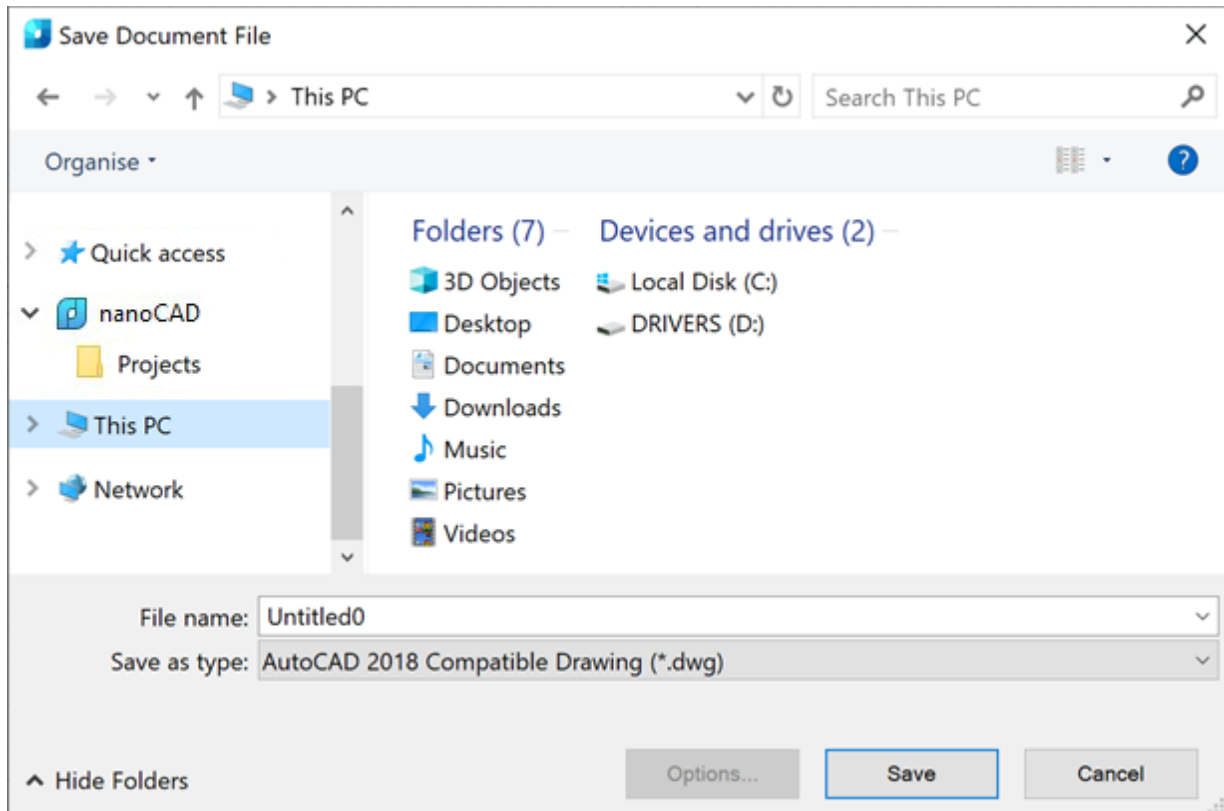

The selected path and the entered file name are set as default values, i.e. in the future, when using the **Save** command, the file will be saved to the location selected by the **Save as** command with the specified name.

The path and name should not be the same as the name of a file opened in another session or by another user (document sharing protection).

Please note: in the **nanoCAD** list on the left side of the dialog, only those user folders are displayed, the path to which is specified in the corresponding subsection of **Common files** of the **Default directories** section of the **Options** dialog:



**To save the document with another name:**

1. Select folder to save the file.
2. Change the name in **File name** field.
3. Select the desired file format in **Save as type** list.
4. Click the **Save** button.

The **Save As** command can be used to change the format of a file, specified to save all documents using **Save**, **Save As** and **WBLOCK**.

## Saving a Document or Its Part Using the **WBLOCK** Command



Command line: **WBLOCK, W, ACADWBLOCKDIALOG**

The **WBLOCK** command is started from the command line and allows saving of an entire document and also part of a drawing using the **Write Block** dialog:

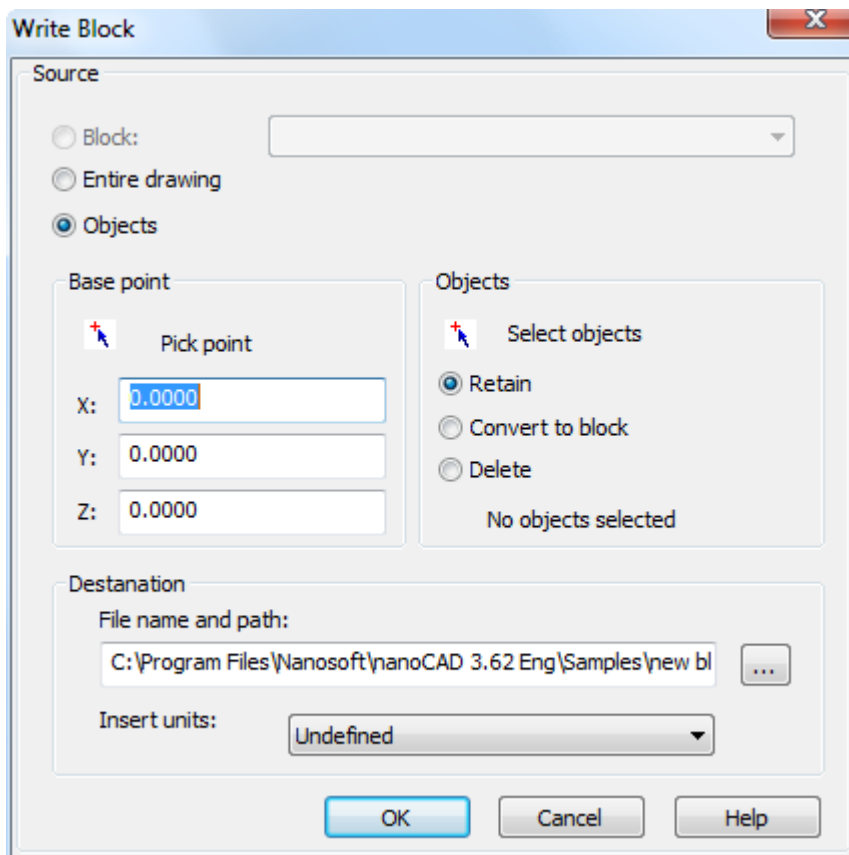

The **Write Block** dialog box complements and extends the capabilities of the **Save** and **Save As** commands, allowing the saving of an entire document (**Entire drawing** parameter) and also part of a drawing (**Block** and **Objects** parameters). For more information, see **Saving a block to a separate file** section.

## AutoSaving and Backup

To minimize losses caused by software or hardware failures and any other consequences, nanoCAD has *auto saving* and *backup* functions.

## AutoSaving

If Autosaving mode is switched on, the data is saved at the specified intervals.

**ATTENTION!** Autosaving mode is automatically disabled while the **REFEDIT** mode is on. After you exit **REFEDIT** mode autosaving automatically resumed.

The time and date of the auto saving is added in round brackets to a file name with **\*.autosave** extension, for example: <file name>.dwg(20-29-44\_15.08.2010).autosave

**NOTE:** The time of autosaving is the time of the first autosaving and it is not updated further.

**NOTE:** If the program is closed normally, autosaved documents are removed. If there is software or hardware failure and any other consequences, autosaved files are not removed.

**NOTE:** You can restore the previous session of a document from the auto saved file. Do not close the program and document, then copy autosaved file to another folder and rename as described below.

A default folder for auto saved files: *C:\Users\User Name\AppData\Local\Temp*.

**ATTENTION!** If you specify another folder for autosaving, the current (open) document is autosaved into the previous folder. The document is saved into the specified folder only after it is opened again.

If a user-defined folder is deleted or renamed, autosave files will be placed in the default folder *C:\Users\User\_name\AppData\Local\Temp*.

To open and work with an auto saved file, change its extension to \*.dwg (delete the additional information in round brackets and the **\*.autosave** extension).

The auto saving parameters are specified in the **AutoSave and Backup** section of the **Options** dialog box (**Tools** menu > **Options**):

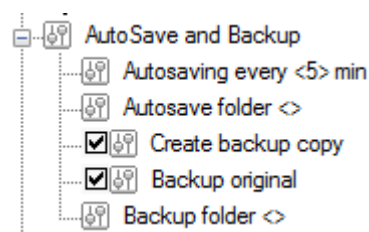

### Parameters:

- |  |   |
|--|---|
| <b>Autosaving every &lt;XX&gt; min</b> | Time interval between savings. To switch off auto saving, set 0 for this parameter. |
| <b>Autosave folder</b>                 | Folder to save files.   |

The first launch of nanoCAD after a failure starts from the **Recover documents** dialog box, containing information about the original file (name, path and creation time) and last autosave time.



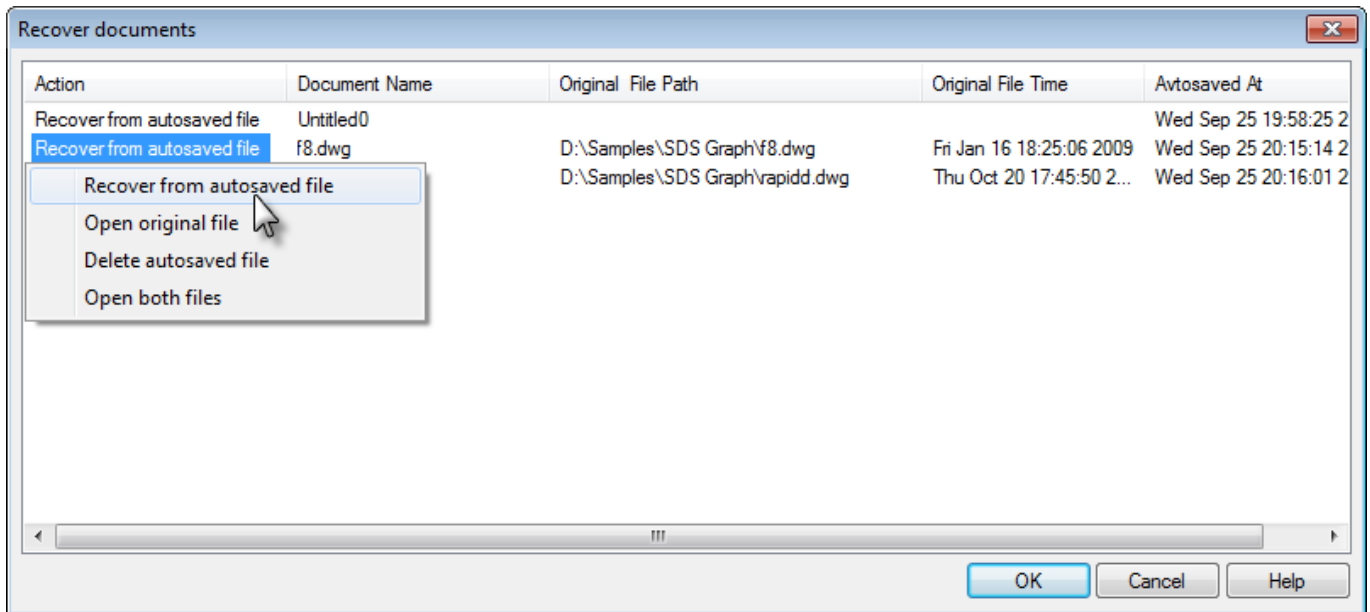

To recover document data, click on the file name and select one of the following in the context menu:

**Recover from autosaved document** Opens the autosaved file with all changes made when the document was autosaved last time.

**Open original file** Ignores the automatically saved version and opens the original document (if it exists). The autosave file in the autosave folder is not deleted.

**Delete autosaved file** Deletes the automatically saved versions. No files are opened.

**Open both files** Opens the original file and a new document restored from the autosave file. The recovered document has not yet been saved anywhere: it contains an asterisk in the title. The header of the recovered document contains the path to the original (source) file and the word (*Recovered*). The AutoSave file in the AutoSave folder is not deleted.

**NOTE** If you click the **Cancel** button in the **Recover Document** dialog, the autosaved file from the autosave folder (Temp by default) is not deleted.

## Backup

nanoCAD creates two backup copies of the file with the same name, but with different extensions.

*Original Backup copy* (file **\*.original**) stores content of the opened or new (but saved!) as it was on first save command. The original backup copy is created only once – on the first editing session. In future sessions, this file will not be overwritten/saved if the path for the **Backup folder** (in **AutoSave and Backup** section in **Options dialog**) was not changed or the backup file was not deleted. Original backup copy (file with **\*.original** extension) saves document data as it was when the file was opened for editing (original backup is created at the beginning of the session of file editing).

Backup copy (file with **\*.bak** extension) is often updated during the document editing process (at every saving by the user). Different contingencies can occur with a document during the working process, for example, malfunctions of hardware, failure of the software or improper

actions of a user. Backup copy allows the user to recover information and minimize losses of information by means of periodic savings (for example, every 15-20 minutes) of the file by the user.

Backup copies are saved in the folder where the document file is saved.

Backup parameters are specified in the **AutoSave and Backup** section of the **Options** dialog box (**Tools** menu > **Options**):

*Parameters:*

- Create backup copy**                      Switches backup mode on/off.
- Backup original**                      Switches original backup mode on/off.
- Backup folder**                      Location to save backup copies.

To recover data from a backup copy, change the file extension to **\*.dwg**.

## *Saving File History and Possibility to Return to Previous States*

Usually, files created as a result of autosave can be useful only in case of abnormal end of the program session, since in this case these files remain on the disk. In case of normal end of work with a document, autosave files are automatically deleted.

Sometimes you may need to return to previous states of a document file, for example, if it wasn't saved by mistake.

In this case you should enable and configure the save file history mode. It is based on the mechanism of autosaving files and is configured in the **Options** dialog box – Section **Save documents – File history**:

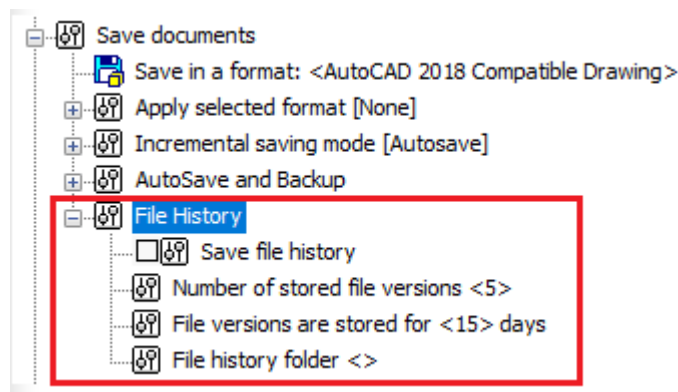

- **Save file history** (FILEHISTORY variable) – whether maintain autosave history or not (0 – disabled or 1 – enabled);
- **Number of stored file versions** (FILEHISTORYMAX variable) – maximum number of autosaved file versions;
- **File versions are stored for <> days** (FILEHISTORYDURATION variable) – period of storing autosaved file versions in the storage (in days).
- **File history folder** – folder for storing autosaved copies.

Files are deleted from the storage:

- when trying to save a file version in the storage, which already contains a number of file versions equal to FILEHISTORYMAX (the earliest version is deleted);

- when closing nanoCAD, the storage period for files in the storage is checked. If the file is in the storage longer than FILEHISTORYDURATION, then it is deleted.

The **Open file history** command (OPENHISTORY) is intended to open a file from the storage.

## Incremental Saving

In the *incremental saving* mode, a file is not overwritten whole, - only changes made after the previous save are added in it. And only if the size of all accumulated changes exceeds half of the original document size, the file will be overwritten in whole.

This significantly accelerates the process of saving large drawings. The incremental save is especially effective when creating backup during autosave.

By default, the incremental saving mode is enabled only for autosave. Normal saving is performed in a standard way.

You can disable the incremental saving mode or enable it for saving operations in the **Incremental saving mode** section of the **Options** dialog:

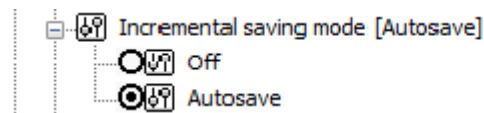

- Off** The mode in which incremental save will not be applied. Full save and full autosave will be performed.
- Autosave** The mode in which full save and incremental autosave will be performed.
- Save and Autosave** The mode in which incremental save and incremental autosave will be performed.

## Import

 nanoCAD button -  **Import**

 Ribbon: **Insert -Import >**  **Import**

 Menu: **File-  Import...**

 Command line: **IMPORT, IMP**

You can import data in AutoCAD format (\*.dwg) and data exchange format (\*.dxf) into nanoCAD documents.

Many existing file formats can be imported in nanoCAD documents, which allows for exchange of graphic and other data of various CAD systems and applications.

The following data formats are imported in nanoCAD documents:

Format	Description
DWG (*.dwg)	One of the most common formats used for 2D and 3D drawings in CAD. Developed by Autodesk. Licensed for use in many applications. It is the main document format in nanoCAD.

<b>Format</b>	<b>Description</b>
DXF (*.dxf)	File format for exchange of graphic information.
DWF (*.dwf)	Open file format for exchange of design data, for reading, printing and reviewing them, developed by Autodesk. This secure, high compression format allows you to combine and publish large amounts of data for shared use.
Metafile (*.wmf)	Microsoft Windows metafiles.
Enhanced Metafile (*.emf)	Microsoft Windows enhanced metafile.
HPGL (*.plt)	Plotter file format HPGL (Hewlett-Packard).
MicroStation DGN (*.dgn)	2D/3D format used by MicroStation structure design program of Bentley Systems.
CWS (*.cws)	Document format of Spotlight, a professional hybrid graphic editor that allows to carry out a full range of works with raster monochrome, grayscale and color images: scanned drawings, maps, diagrams and other graphic materials.

The following 3D formats are also available for import when using C3D graphics engine:

<b>Format</b>	<b>Version</b>	<b>Description</b>
Parasolid (*.x_t; *.x_b)	25.0	File formats of Parasolid geometric kernel. They are used by such CAD-systems as NX, Solid Edge, SolidWorks.
IGES (*.igs; *.iges)	5.3	Digital Representation for Communication of Product Definition Data — 2D/3D vector graphics format; is used to transfer 2D and 3D data of drawings between dissimilar CAD systems.
STEP (*.step; *.stp)	203, 214	Standard for Exchange of Product model data — a set of ISO 10303 standards used in CAD, which allows describing the entire lifecycle of a product, including manufacturing technology and products quality control. It is gradually replacing IGES standard due to its wider information storage capabilities.
ACIS (*.sat)	22.0	Format to exchange data between 3D modeling systems using ACIS core.
VRML (*.wrl)	2.0	File format for describing interactive 3D objects and virtual worlds. VRML is designed for use in Internet and is the standard of 3D graphics in the Network.
STL (*.stl)	-	A layout format used for stereolithography. The field of stereolithography includes 3D models of layout images used in order to form control models for creating a large number of copies.
JT (*.jt)	-	An open format for describing 3D data used for visualization, shared work and data exchange in CAD.
COLLADA (*.dae)		A universal 3D format that supports any type of data (splines, geometry, light, materials, animation, etc.).
C3D (*.c3d)		An extended storage format for the geometric model that supports reading individual model objects from a file in an arbitrary order and allows you to obtain information about the model structure and its objects without loading the entire model from the file.
Rhino		Rhinoceros (Rhino) is a commercial 3D NURBS modeling software developed by Robert McNeel & Associates. Used in industrial

(*.3dm)		<p>design, architecture, ship design, jewelry and automotive design, CAD/CAM design, rapid prototyping, reverse engineering, as well as multimedia and graphic design.</p> <p>Limited support for this format (import of a number of basic entities) has been implemented.</p>
---------	--	--

**To import data:**

1. Start the **File – Import** command;
2. In the **Open Vector File** dialog box select a format and specify a file name;

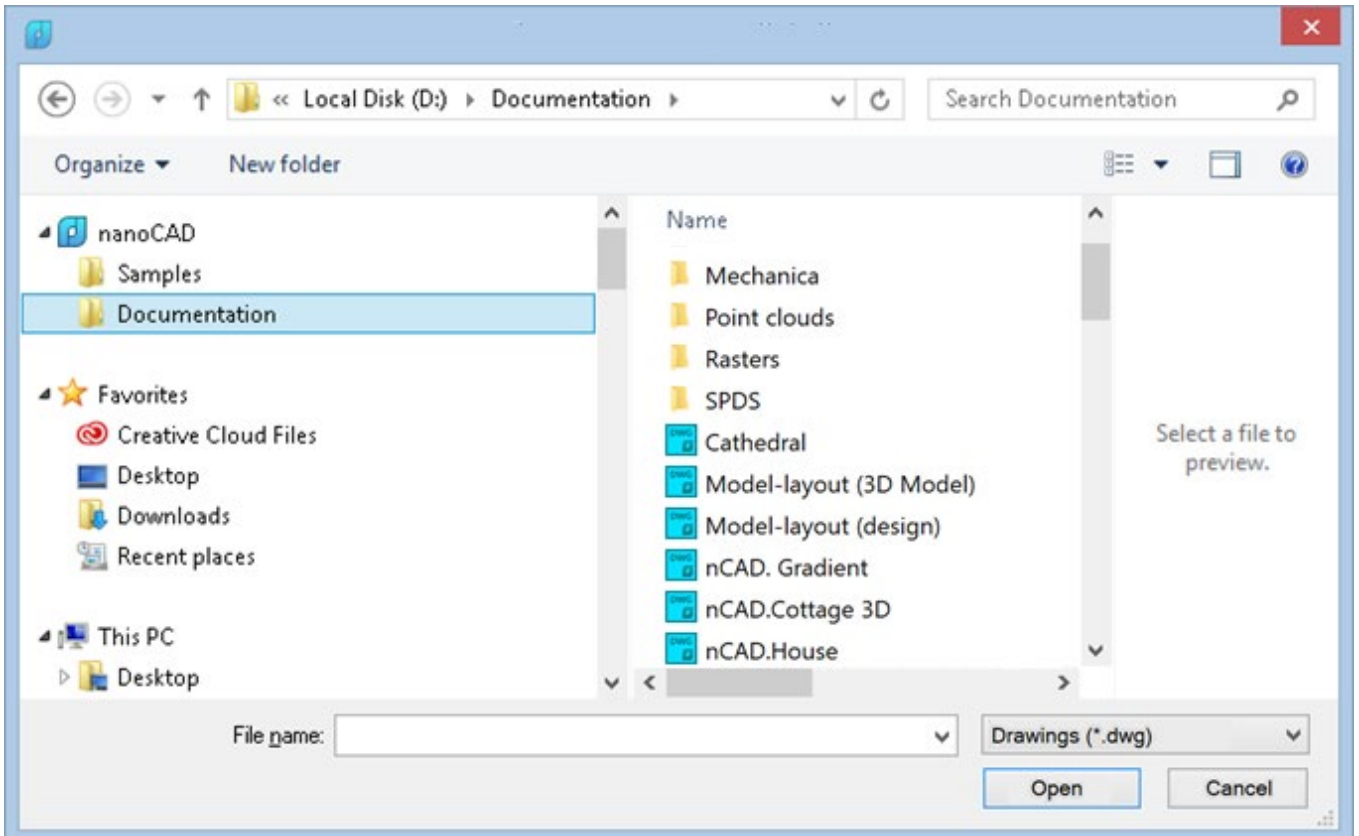

3. Select **Open**.

The ways to use templates for imported documents are set in the **Options: Template Usage > For imported documents**. For conditions of template usage see in the "Template usage" section.

## Importing PDF Files Data

 nanoCAD button – **Import** >  **PDF**

 Ribbon: **Insert –Import** >  **PDF Import**

 Menu: **File –**  **Import PDF**

 Command line: **PDFIMPORT**

You can import geometry, raster images and TrueType text objects from PDF files into nanoCAD documents.

Based on the tasks, you can import PDF files data in different ways:

1. Import data of the entire PDF file or a selected page as nanoCAD objects.
2. Convert the inserted PDF underlay in whole or in part into nanoCAD objects.

Note that when importing PDF data, visual information is retained, but the objects themselves will be converted. The conversion result depends on how the objects were saved in the PDF file.

**To import PDF files data:**

1. Run the menu command **File – Import PDF**.
2. In the **Open** dialog box, select PDF file to be imported, click the **Open** button.
3. Set the desired parameters in the **Import PDF** dialog box.
4. When importing from multi-page files, select the page or pages to be imported. Pages can be selected by clicking on the thumbnail picture or by entering the page number of the **Select** field. To select several pages, their numbers should be separated by commas. Multiple selection of page thumbnails can be performed when holding down **SHIFT** or **CTRL** keys.
5. Click **OK**.

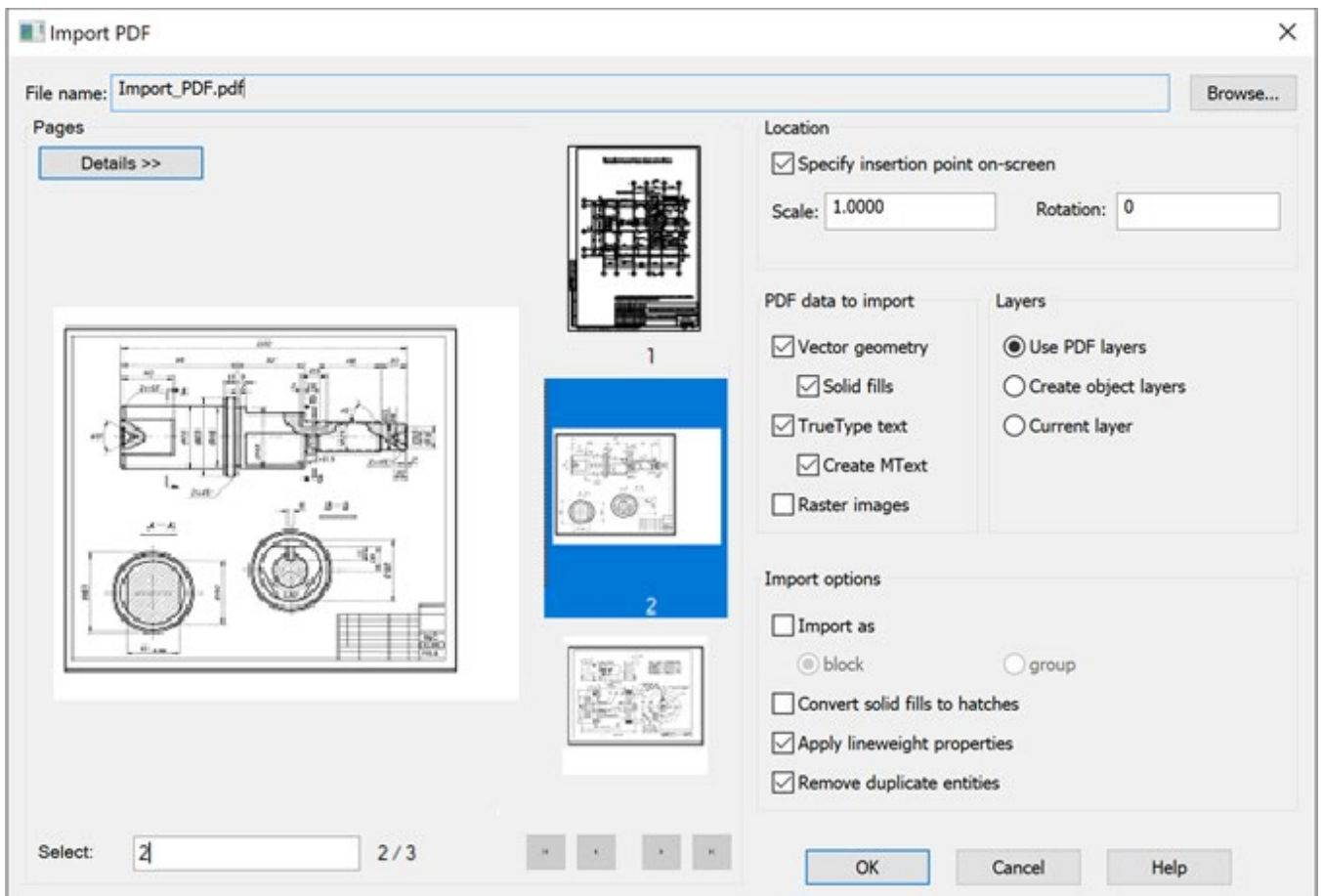

**Options:**

**File name:**

Name of the file to import.

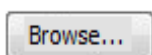

Button to call the **Open** dialog box to select another PDF file to import.

**Pages**

Display of file data and selection of pages when importing multi-page files.

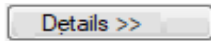

Enables/Disables information about the page being inserted (type, size, measurement units).



Buttons to control the page display scale in the dialog viewport.

### Select

Displays and enters imported pages numbers. You can insert several pages at once by listing them separated by commas.



Buttons to control transition between file pages in the dialog box.

### Location

#### Specify insertion point on-screen

Enables/Disables the mode to select the data insertion point through indicating by cursor on the screen after closing the dialog box.

#### Scale

Sets a different scale for the imported data.

#### Rotation

Sets the rotation angle when importing.

### PDF data to import

Selecting specific data to import.

#### Vector geometry

Imports PDF vector data.

##### Solid fill

Inclusion of all areas having a solid fill in import.

#### TrueType text

Imports text objects created with TrueType fonts.

##### Create Mtext

Creates multiline text when importing TrueType text.

Text objects that use SHX fonts are imported as geometric objects.

#### Raster images

Imports raster images by saving them into external files and subsequently inserting into the current document.

Image files are saved by default to the folder specified in the **Options > Standard Directories > PDF import images location**.

### Layers

#### Use PDF layers

Creates layers based on PDF life layers when importing. Layers names will begin with **PDF** prefix.

#### Create object layers

Creates layers for each of the common types of objects imported from PDF file: **PDF\_Geometry**, **PDF\_Images** and **PDF\_Text**.

#### Current layer

Places imported data on the current layer.

### Import options

#### Import as

##### Block

Selects the data import options.

##### Group

the imported data into a block or combine.

the imported data into a group.

#### Convert solid fills to hatches

Converts solid fill to solid hatch.

#### Apply lineweight properties

Imports vector geometry with the same lineweight as in PD file.

When the option is disabled, vector geometry is imported with default lineweight.

## Remove duplicate entities

Disabling this option may speed up file import.

## Importing PDF Underlay Data



nanoCAD button – Utilities >



Converting PDF to DWG



Menu: **File – Drawing Utilities** >



Converting PDF to DWG



Command line: **PDF2DWG**

The command converts PDF underlay (fully or partially) into nanoCAD objects. PDF underlay should be inserted into the document in advance.

### To convert PDF underlay data:

1. Run the **PDF2DWG** command.
2. Select the PDF underlay.
3. Specify on the screen a rectangular area to import part of objects or select the **All** option in the command line to import all underlay data.
4. At the prompt in the command line: `Keep or upload PDF underlay?`  
`[Keep/Upload] <Upload>` - select the desired option.

The uploaded underlays are not displayed and are not printed, but references to them are saved in the **External references** dialog.

The **Options** command line option opens a brief dialog **PDF import settings** to set import parameters.



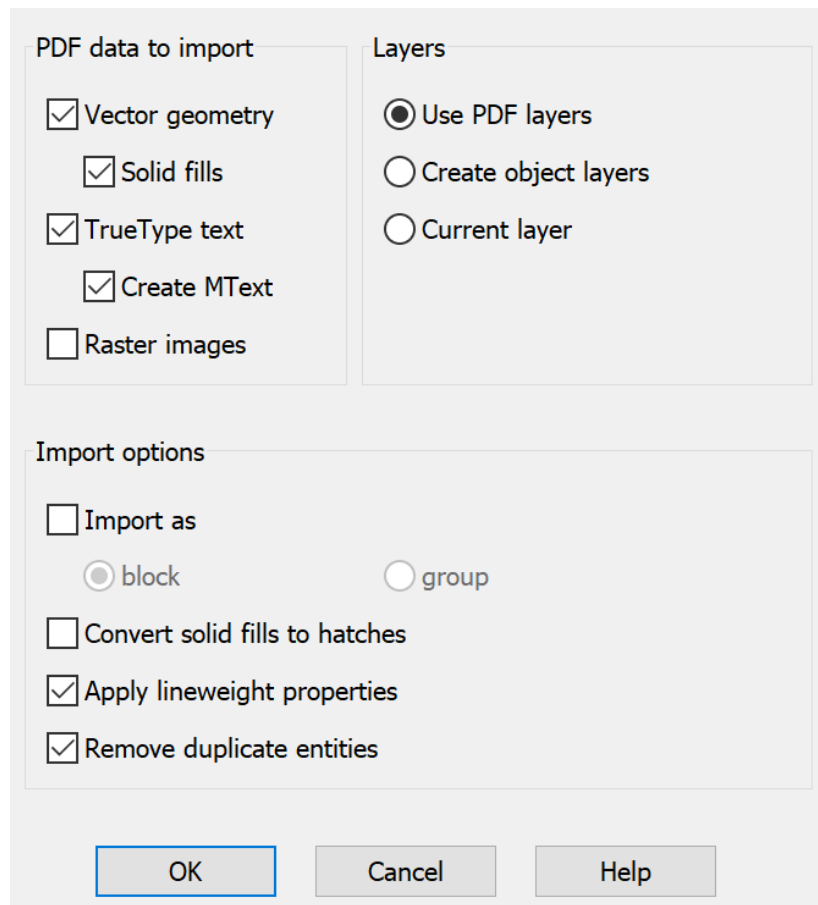

**Options:**

*PDF data to import*

Selection of certain data for import.

- Vector geometry** Import of PDF vector data.
- Solid fill** Inclusion of all areas having a solid fill in import.
- TrueType text** Import of text objects created with TrueType fonts.
- Create Mtext** Creates multiline text when importing TrueType text. Text objects that use SHX fonts are imported as geometric objects.
- Raster images** Import of raster images by saving them into external files and subsequent insertion into the current document. Image files are saved by default to the folder specified in the **Options > Standard Directories > PDF import images location**.







*Layers*

- Use PDF layers** Creates layers based on PDF life layers when importing. Layers names will begin with **PDF** prefix.
- Create object layers** Creates layers for each of the common types of objects imported from PDF file: **PDF\_Geometry**, **PDF\_Images** and **PDF\_Text**.
- Current layer** Places imported data on the current layer.

### Import parameters

<b>Import as Block Group</b>	Selection of data import option: combine imported data in a block or combine imported data in a group.
<b>Convert solid fills to hatches</b>	Converting solid fill to solid hatch.
<b>Apply lineweight properties</b>	Importing vector geometry with the same lineweight as in PDF file. When the option is disabled, vector geometry is imported with default lineweight.
<b>Remove duplicate entities</b>	Disabling this option may speed up file import.

## Export

-  nanoCAD button -  **Export**
-  Ribbon: **Output -Export >**  **Export**
-  Menu: **File -**  **Export...**
-  Command line: **EXPORT, EXP**

A nanoCAD document can be exported to AutoCAD format (\*.dwg) and data exchange format (\*.dxf). Either the entire document or a part of it can be exported.

nanoCAD document data can be exported to:

- document format AutoCAD (\*.dwg);
- file format for exchange of graphical information (\*.dxf);
- 3D PDF (\*.pdf) format to visualize 3D models in Acrobat Reader;
- DWF (\*.dwf, \*.dwx) format for exchange of large volumes of data of 2D and 3D design, reading, printing and reviewing;
- STL (\*.stl) layout format used for stereolithography. STL files are used in additive manufacturing to create 3D prototypes from 3D CAD models. Export options available for STL.

You can export both the entire document content or only selected data.

When using C3D graphics engine, the following 3D are also available for export:

Format	Version	Description
Parasolid (*x_t; *x_b)	10.0	Text and binary file formats of Parasolid geometric kernel. They are used by such CAD-systems as NX, Solid Edge, SolidWorks.
IGES (*igs; *iges)	5.3	Digital Representation for Communication of Product Definition Data — 2D/3D vector graphics format; is used to transfer 2D and 3D data of drawings between dissimilar CAD systems.
STEP (*step; *.stp)	203, 214	Standard for Exchange of Product model data — a set of ISO 10303 standards used in CAD, which allows describing the entire lifecycle of a product, including manufacturing technology and products quality control. It is gradually replacing IGES standard

		due to its wider information storage capabilities.
ACIS (*.sat)	2.0	Format to exchange data between 3D modeling systems using ACIS core.
VRML (*.wrl)	2.0	File format for describing interactive 3D objects and virtual worlds. VRML is designed for use in Internet and is the standard of 3D graphics in the Network.
JT (*.jt)	-	An open format for describing 3D data used for visualization, shared work and data exchange in CAD.
COLLADA (*.dae)		A universal 3D format that supports any type of data (splines, geometry, light, materials, animation, etc.).
C3D (*.c3d)		An extended storage format for the geometric model that supports reading individual model objects from a file in an arbitrary order and allows you to obtain information about the model structure and its objects without loading the entire model from the file.

Unlike the **Save as** command, the **Export** command allows you to save the edited document with a new name without closing it.

## Export of All Data

In the **Save Document File** dialog box:

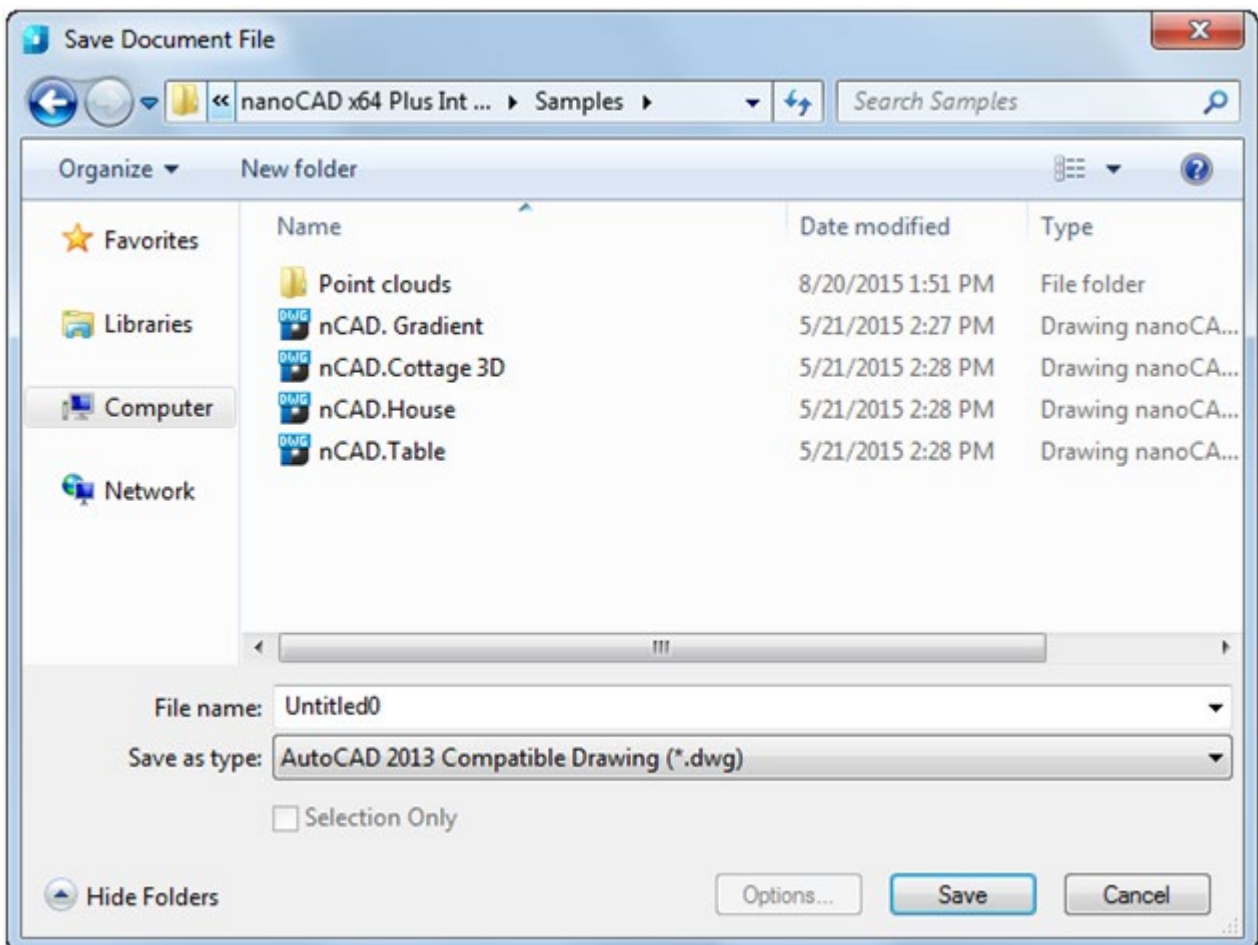

1. Specify the path for the exported file in the **Folder** drop-down list.
2. Type a name in the **File name** field.
3. Select a format in the **File type** field.

4. Select the **Save** button.

Please note: In the **nanoCAD** list of dialog transition areas, only those user folders are displayed, the path to which is specified in the **Common files location** subsection of the **Standard directories** section of the **Options** dialog:

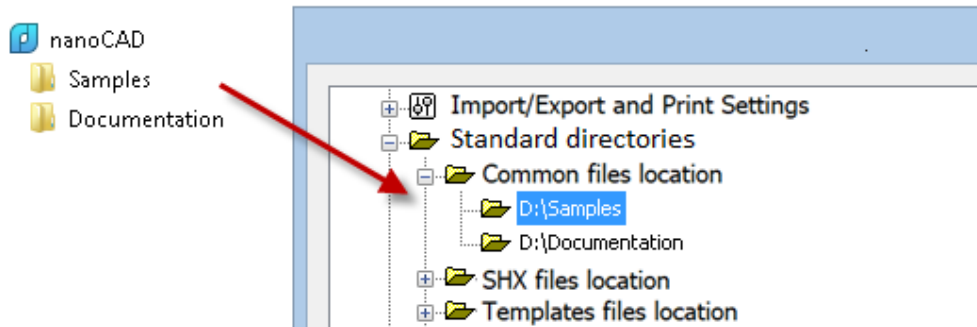

## Export of Selected Data

The export procedure for selected data is the same as the export procedure for all the data, except that the **Selection Only** checkbox is selected in the **Save Document File** dialog box:

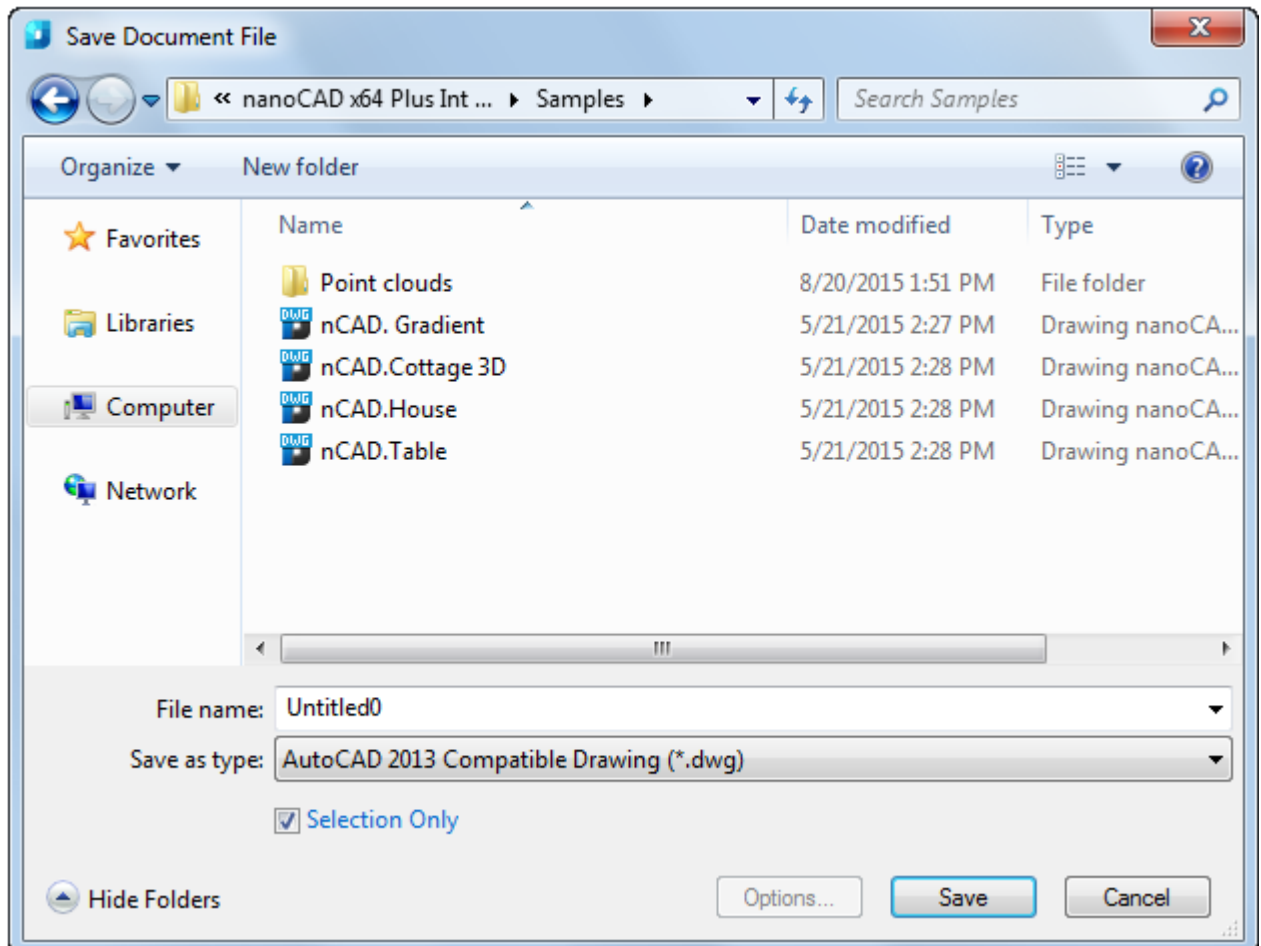

**ATTENTION!** If no objects were selected before saving, the **Selection Only** checkbox is unavailable.

## Export to Stereolithography Format

When exporting data to stereolithography (STL) format, the **Settings** button becomes available; it opens the export options dialog box.

**Options:**

<p><b>Visible objects only</b></p>	<p>Exports only the active model and construction geometry that is displayed in a part or assembly. If this option is selected, then only working bodies are exported. Simplified bodies contained in an assembly are not exported.</p>
<p><b>Structure of STL files</b></p>	<p>Determines the structure of a document in STL format:</p> <ul style="list-style-type: none"> <li>• <b>One STL file</b> – creates one STL document containing assembly components. This option is not available in documents for parts.</li> <li>• <b>STL document for each component</b> – creates separate STL documents for each component in the assembly.</li> </ul> <p>Only working bodies are exported to STL format. Auxiliary bodies and simplified data are not exported to STL format.</p>
<p><b>Accuracy parameters</b></p>	<p>Specifies the tessellation of the model document for stereolithography (STL) output.</p> <ul style="list-style-type: none"> <li>• <b>High</b> –sets high accuracy of <b>Conversion accuracy</b> and <b>Normal deviation</b> parameters (1 degree).</li> <li>• <b>Low</b> – sets low accuracy of <b>Conversion accuracy</b> and <b>Normal deviation</b> parameters (60 degrees). Low accuracy gives a rough breakdown.</li> <li>• <b>Other</b> – makes it possible to set arbitrary values for the <b>Conversion accuracy</b> and <b>Normal deviation</b> parameters. You can enter a value using the keyboard or using the slider.</li> </ul> <p>The lower the values, the greater the overall accuracy of the part in the generated files.</p>

<p><b>Conversion accuracy</b></p>	<p>Specifies the conversion accuracy with which the triangle mesh is spaced from the surface to be converted.</p> <p>The conversion accuracy controls the number of tessellation faces (facets) in the model. The higher the tessellation value, the rougher the model is, since larger faceted faces are used. The lower the tessellation value, the more accurate and smoother the model is.</p> <p>The higher the accuracy, the larger the file size is.</p> <p>The maximum allowable value of the parameter (in mm) is determined by the dimensions of the exported model. The larger it is, the greater the allowable value. The maximum value gives a rough breakdown.</p> <p>When setting values with a slider, the minimum value of the parameter is automatically calculated in proportion to the dimensions of the scene so as to provide high detail.</p> <p>If a model with a more accurate breakdown is required than it is possible to be entered using the slider, then it can be entered from the keyboard. In this case, the minimum allowable value will be 0.000001 mm.</p> <p>With a very small value of the parameter (and therefore high detail), the export can take a very long time, so such values can only be entered from the keyboard.</p>
<p><b>Normal deviation</b></p>	<p>Specifies the angular accuracy of a surface that can be considered flat. This is the upper limit of non-parallelism of normals to the surface at any two points below the surface.</p> <p>The lower the value, the more accurate the model is. This is especially noticeable in the small details of the exported 3D object.</p> <p>The angle of deviation of the normal is set with a slider in the range from 1 to 60 degrees. You can also enter a value using the keyboard.</p>

## Export to JT Format

When exporting data to JT format, the **Settings** button becomes available; it opens the export options dialog box.

### Options:

<p><b>Visible objects only</b></p>	<p>Exports only the active model and construction geometry that is displayed in a part or assembly.</p> <p>If this option is selected, then only working bodies are exported. Simplified bodies contained in an assembly are not exported.</p>
------------------------------------	--

<p><b>Accuracy parameters</b></p>	<p>Specifies the tessellation of the model document.</p> <ul style="list-style-type: none"> <li>• <b>High</b> –sets high accuracy of <b>Conversion accuracy</b> and <b>Normal deviation</b> parameters (1 degree).</li> <li>• <b>Low</b> – sets low accuracy of <b>Conversion accuracy</b> and <b>Normal deviation</b> parameters (60 degrees). Low accuracy gives a rough breakdown.</li> <li>• <b>Other</b> – makes it possible to set arbitrary values for the <b>Conversion accuracy</b> and <b>Normal deviation</b> parameters. You can enter a value using the keyboard or using the slider.</li> </ul> <p>The lower the values, the greater the overall accuracy of the part in the generated files.</p>
<p><b>Conversion accuracy</b></p>	<p>Specifies the conversion accuracy with which the triangle mesh is spaced from the surface to be converted.</p> <p>The conversion accuracy controls the number of tessellation faces (facets) in the model. The higher the tessellation value, the rougher the model is, since larger faceted faces are used. The lower the tessellation value, the more accurate and smoother the model is.</p> <p>The higher the accuracy, the larger the file size is.</p> <p>The maximum allowable value of the parameter (in mm) is determined by the dimensions of the exported model. The larger it is, the greater the allowable value. The maximum value gives a rough breakdown.</p> <p>When setting values with a slider, the minimum value of the parameter is automatically calculated in proportion to the dimensions of the scene so as to provide high detail.</p> <p>If a model with a more accurate breakdown is required than it is possible to be entered using the slider, then it can be entered from the keyboard. In this case, the minimum allowable value will be 0.000001 mm.</p> <p>With a very small value of the parameter (and therefore high detail), the export can take a very long time, so such values can only be entered from the keyboard.</p>
<p><b>Normal deviation</b></p>	<p>Specifies the angular accuracy of a surface that can be considered flat. This is the upper limit of non-parallelism of normals to the surface at any two points below the surface.</p> <p>The lower the value, the more accurate the model is. This is especially noticeable in the small details of the exported 3D object.</p> <p>The angle of deviation of the normal is set with a slider in the range from 1 to 60 degrees. You can also enter a value using the keyboard.</p>

## Integration with CAE Fidesys

CAE Fidesys is a strength analysis package, it is a convenient and effective tool that allows you to carry out a full cycle of strength engineering analysis:

- Loading and analysis of CAD model;

- Creating computation grid;
- Settings loads and mechanic properties of material;
- Selecting and adjusting FEM solver;
- Calculation of model;
- Visualizing calculation results.

Interaction with CAE Fidesys is possible if *FidesysBundle* is installed on the user's computer and through a cloud solution – *Sim4Design*, which requires an Internet connection and a modern browser.

The commands to manage integration process are located in the menu **Tools – Fidesys**:

- **Open in FidesysBundle**
- **Export model for Sim4Design**
- **Download CAE Fidesys**

## Open in FidesysBundle



Ribbon: **Output – Export** >  **Open in FidesysBundle**



Menu: **Tools – Fidesys** >  **Open in FidesysBundle**



Command line: **FIDESYSEXPORTTOBUNDLE**

Uploads the current 3D model (if any) to the FidesysBundle package for further full engineering analysis.

## Export Model for Sim4Design



Ribbon: **Output – Export** >  **Export model for Sim4Design**



Menu: **Tools – Fidesys** >  **Export model for Sim4Design**



Command line: **FIDESYSEXPORTFORCLOUD**

Allows you to save the current model in a suitable format for use in Sim4Design cloud ([www.sim4design.com](http://www.sim4design.com)).

## Download CAE Fidesys



Ribbon: **Output – Export** >  **Download CAE Fidesys**



Menu: **Tools – Fidesys** >  **Download CAE Fidesys**



Command line: **FIDESYSDOWNLOADBUNDLE**

Opens the FidesysBundle download page the access to 30-day trial version.

## Create Transmit Package



nanoCAD button -  **Etransmit**



Ribbon: **Output – Export** >  **Etransmit**





Menu: **File – Etransmit...**



Command line: **ETRANSMIT**

This function forms packages of files for transmitting to other computer or transmission by internet. Transmittal package includes all drawing-related files such as xrefs and font files.

**NOTE:** In some CAD “*set of files*” term is used instead “*package of files*”.

**Create transmittal** dialog box displays table with all drawing-related files (xrefs, fonts etc.). The dialog shows information about every file in transmittal: **Name, Size, Type, Date, Saved path.**

- current drawing file and attached external links (\*.dwg);
- font files (\*.shx, \*.ttf);
- \*.dwf files;
- \*.dgn files;
- \*.pdf files;
- raster files, including texture rasters;
- point cloud files;
- linestyle files;
- 3D files.

The table provides information about each file included in the package: **Name, Size, Type, Date, Saved Path:**

Formation of a package of files
✕

**Statistics**

Total underlays: 2 pcs (Loaded: 2 pcs) (Unloaded: 0 pcs) (Other status: 0 pcs)

Total external links: 2 pcs (Loaded: 2 pcs) (Unloaded: 0 pcs) (Other status: 0 pcs)

**Current drawings:** ☰ ☰

		Name	Size	Type	Date	Saved Path
	✓	Etransmit Project.d...	286 KB	Current Drawing	1/24/2024 ...	C:\Users\Asus\Desktop\nanc
	✓	Cloud.dwg	281 KB	Attach	1/31/2023 ...	C:\Users\Asus\Desktop\nanc
	✓	GOST 2.303-68.shx	73 bytes	Font	1/10/2024 ...	C:\ProgramData\Nanosoft A
	✓	ABCD.303833.001 S...	227 KB	Attach	1/24/2024 ...	C:\Users\Asus\Desktop\nanc
	✓	arial.ttf	0,98 MB	Font	12/7/2019 ...	C:\Windows\FONTS\arial.ttf
	✓	CS_Gost2304.shx	30,1 KB	Font	1/10/2024 ...	C:\ProgramData\Nanosoft A
	✓	03.jpg	1,57 MB	JPG	8/14/2023 ...	C:\Users\Asus\Desktop\03.jp
	✓	Import_PDF.pdf	17,8 KB	PDF	8/7/2023 1...	C:\Users\Asus\Desktop\Impe

Form a package

Settings

Add file...

Send the current drawing

Cancel

Help

To switch the display of files in the form of a hierarchical tree, click the  button.

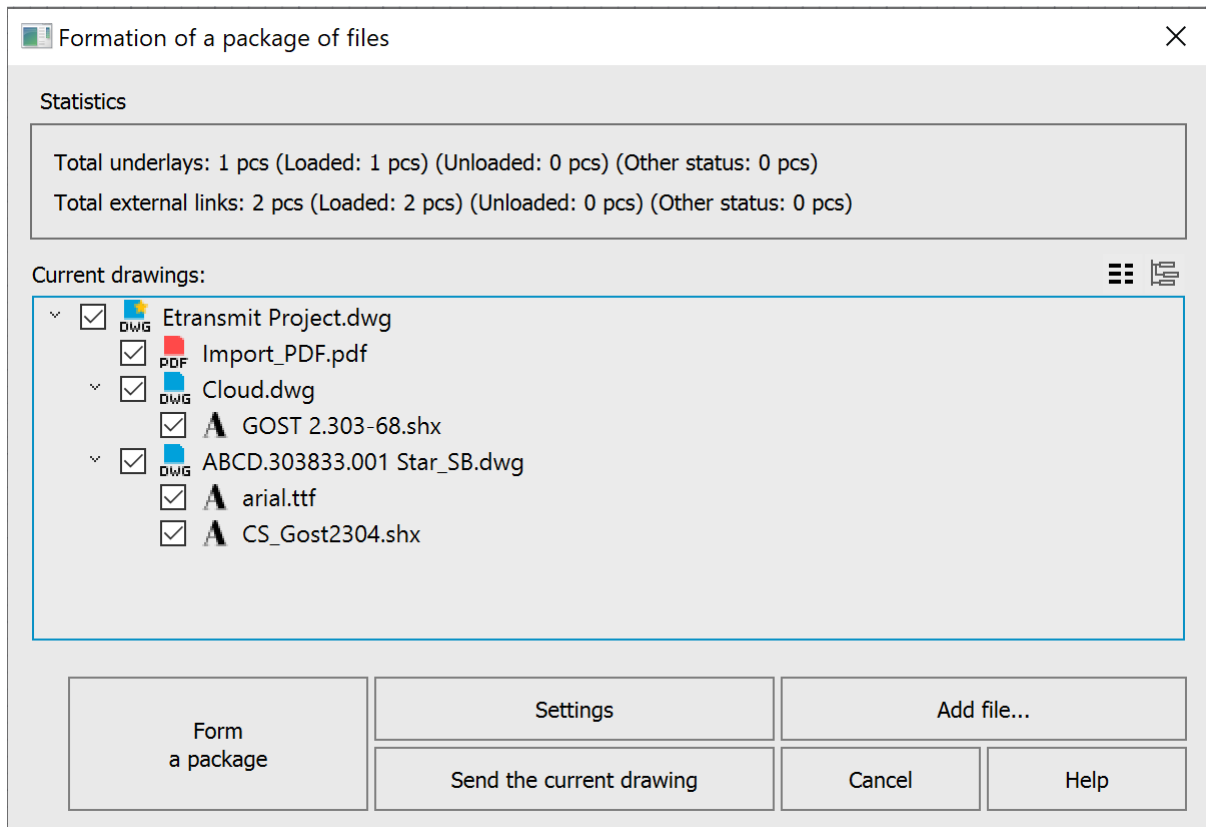

Files marked with ✓ and  are included in transmittal package.

At the top of the window, statistics on loaded and unloaded external links and underlays are displayed.

*Buttons:*

**Form a package**

Starts the formation of a package of files (\*.zip), creates a file of \*.eml format and automatically opens it with the mail client installed on the computer. The generated package (zip archive) is attached.

**Send the current drawing**

Starts the formation of an \*.eml file and automatically opens it with the mail client installed on the computer. The current drawing is attached.

**Settings**

Opens the **Settings for generating a package of files** dialog:

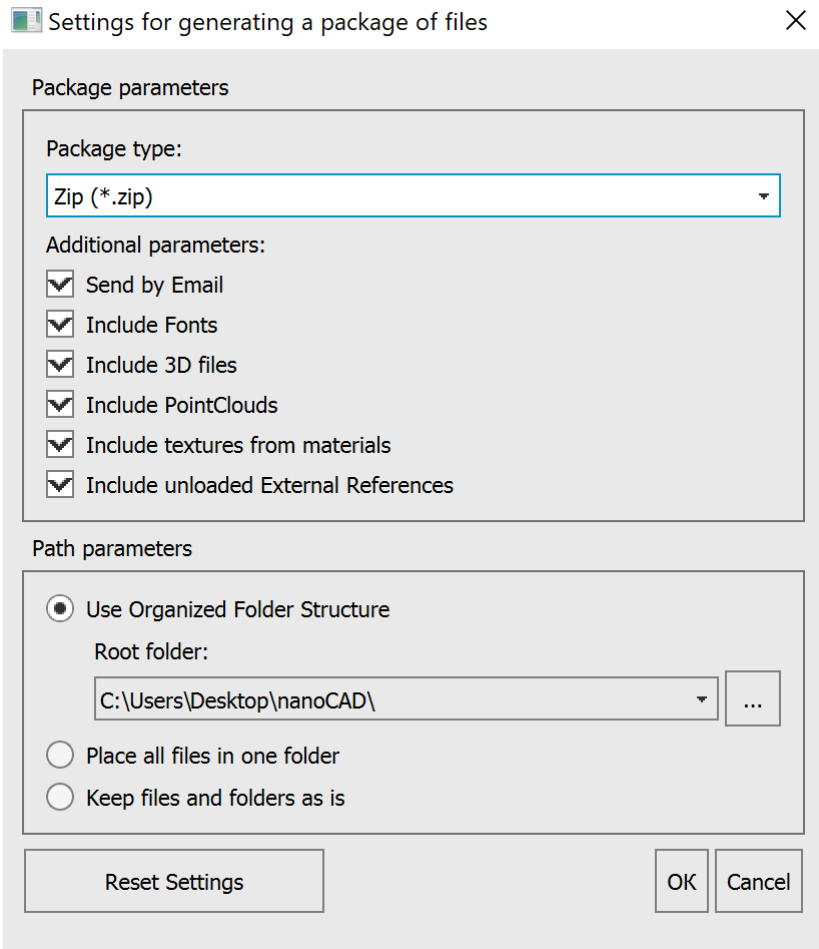

### **Package parameters**

#### *Package type:*

- Zip (\*.zip)** – creates a package of files in the form of a zip archive;
- Folder with files (not sent by email)** – creates a package of files in the form of a folder with files.

#### *Additional parameters:*

- Send by Email** – enables the mode of generating a \*.eml file;
- Include fonts** – includes font files in the package (the Fonts folder is created);
- Include 3D-files** – includes 3D-files in the package;
- Include point clouds** – includes point clouds in the package;
- Include textures from materials** – includes texture files created and/or used in the drawing into the package (the Textures folder is created);
- Include unloaded External References** – includes unloaded external references in the file package.

#### *Path parameters*

- Use Organized Folder Structure** – duplicates the folder structure for files of the generated package, changing absolute paths to relative ones. The root folder is the top-level folder in a hierarchical folder tree.
- Place all files in one folder** – all files will be placed in one folder.
- Keep files and folders as is** – the folder structure that existed at the time the package was created is completely preserved.

**Add file**

Opens a standard file open dialog for manual adding a file to a package.

**Cancel**

Closes the dialog box without saving changes.

### To create transmittal package:

1. Run **Etransmit** command.
2. To include additional files, click the **Add file...** button in the **Create Transmittal** dialog box, then select files in standard dialog **Open**.
3. Clear check boxes for unnecessary files to exclude them from package.
4. Click **OK**. Specify a file name and locate the folder where you want to create the transmittal package in **Save as** dialog box. Transmittal package saves in a self-extracting **ZIP-file**.

The generated package of files also includes an information file with the \*.txt extension, containing a list of all included and excluded files (including folders), instructions and notes for users.

You can set up Etransmit settings in the **Etransmit** section of the **Options** dialog (menu **Tools – Options**).

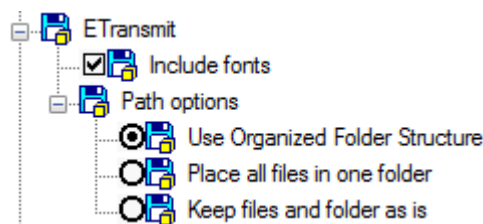

## CAD Standards

The application of standards is relevant in case of collaborative work on one project. In this case it may be necessary to create corporate standards to ensure the uniformity of drawing files design, which would simplify the understanding of drawings by other team members, shorten the time of the project work and reduce the number of possible errors.

The use of standards determines the sets of common properties of a drawing's named objects, such as layers, text styles, dimension styles, linetypes. A user or administrator can create, use and check standards preset in drawings. The check for standards violations can be carried out both manually and automatically, for example, when saving, plotting, replicating a document.

### Creating a Standards File

After the standard is defined, it should be saved in a standards file – a file with DWS extension. One standards file can be associated with several drawing files. A drawing associated with a standards file can be checked for these standards violations automatically and manually.



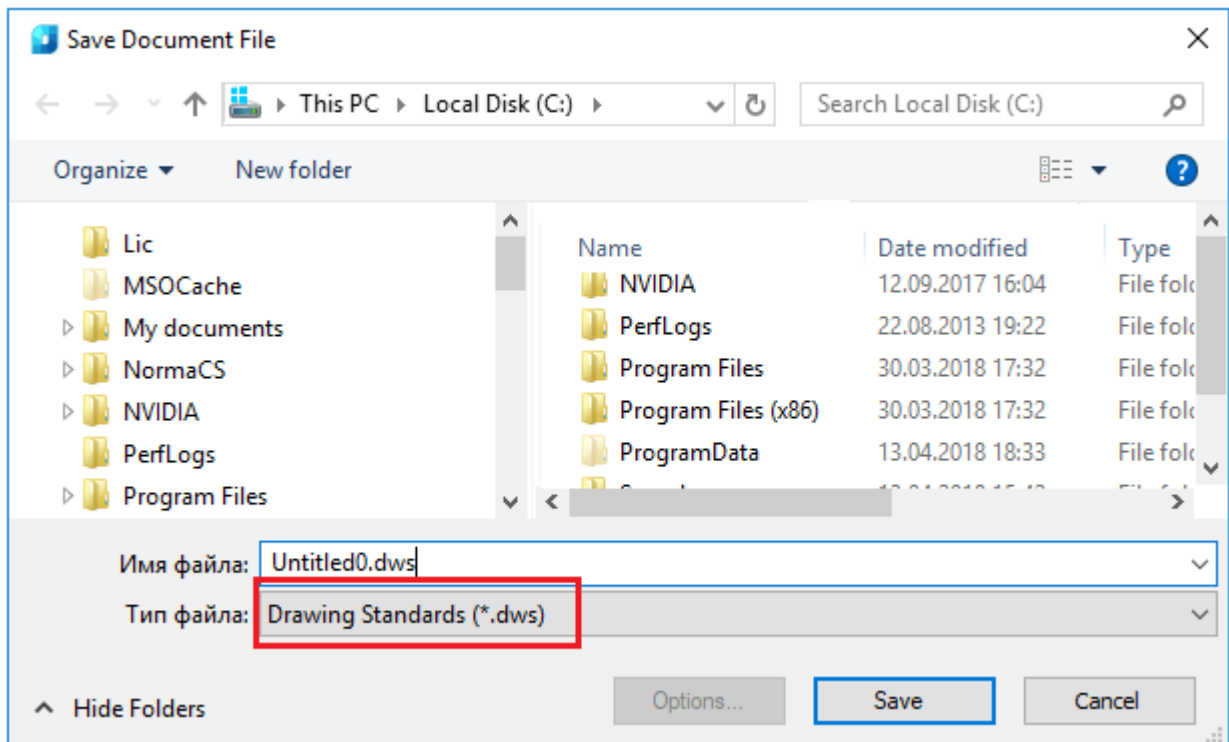



To create a standards file, open a new document, in which configure layers, dimension styles, linetypes and text styles in accordance with the established norms. Then save the document in DWS format using **Save as** command.



DWS-files should be saved in the current program version format. To save a DWS-file in a previous version format, first save the file in the desired version DWG format, and then rename it by changing extension to .dws.

One standard file can be associated with several drawing files. A drawing associated with a standard file can be checked for these standards violation in automatic and manual mode.

## Association of Standards with a Document

-  Ribbon: **Manage – CAD Standards >**  **Configure Standards**
-  Menu: **Tools – CAD Standards >**  **Configure...**
-  Status bar: context menu of the button  **Check standards > Configure standards...**
-  Command line: **STANDARDS**

**NOTE:** The  **Standards audit** button is displayed in the status bar only if at least one standard file was associated with a drawing.

To be able to check the document for the relevant standards, associate the standards file with the document.

When trying to check standards of a document not associated with a single standards file, an alert will appear:

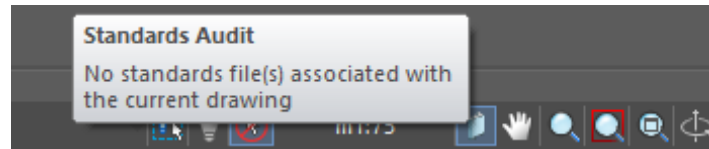
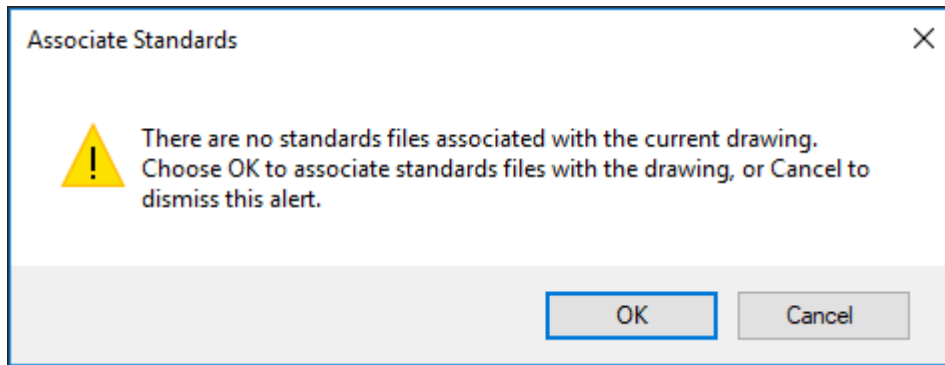

Standards are associated with a document in the **Configure standards** dialog box. You can open it from the ribbon, from the menu or directly by reference in pop-up message.

### Standards tab

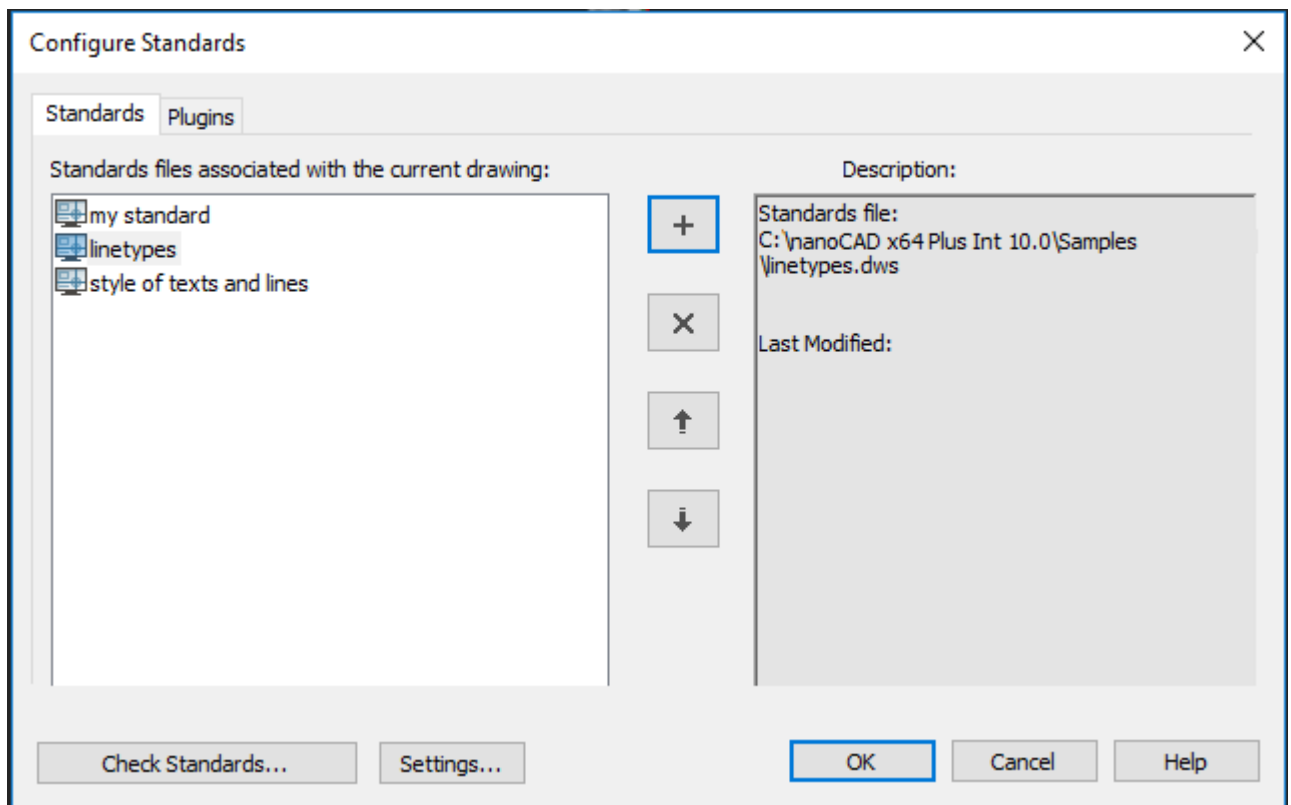

On this tab you can associate standards files with a document and set the sequence of checking files.

The left part of the box displays the associated standards files, the right one gives a brief description.



Associate a new standards file.

One standards file can be associated with several drawing files.



Disable the selected standards file.



When checking a drawing, there may be conflicts between norms in different standards files, if different values are set in several standards files for one and the same parameter, for example, color of the particular layer. In such cases the higher priority is for the standards file, which is located higher in the list. If necessary, the standards file order can be changed by buttons to change the parameters' priority.

### Configure tab

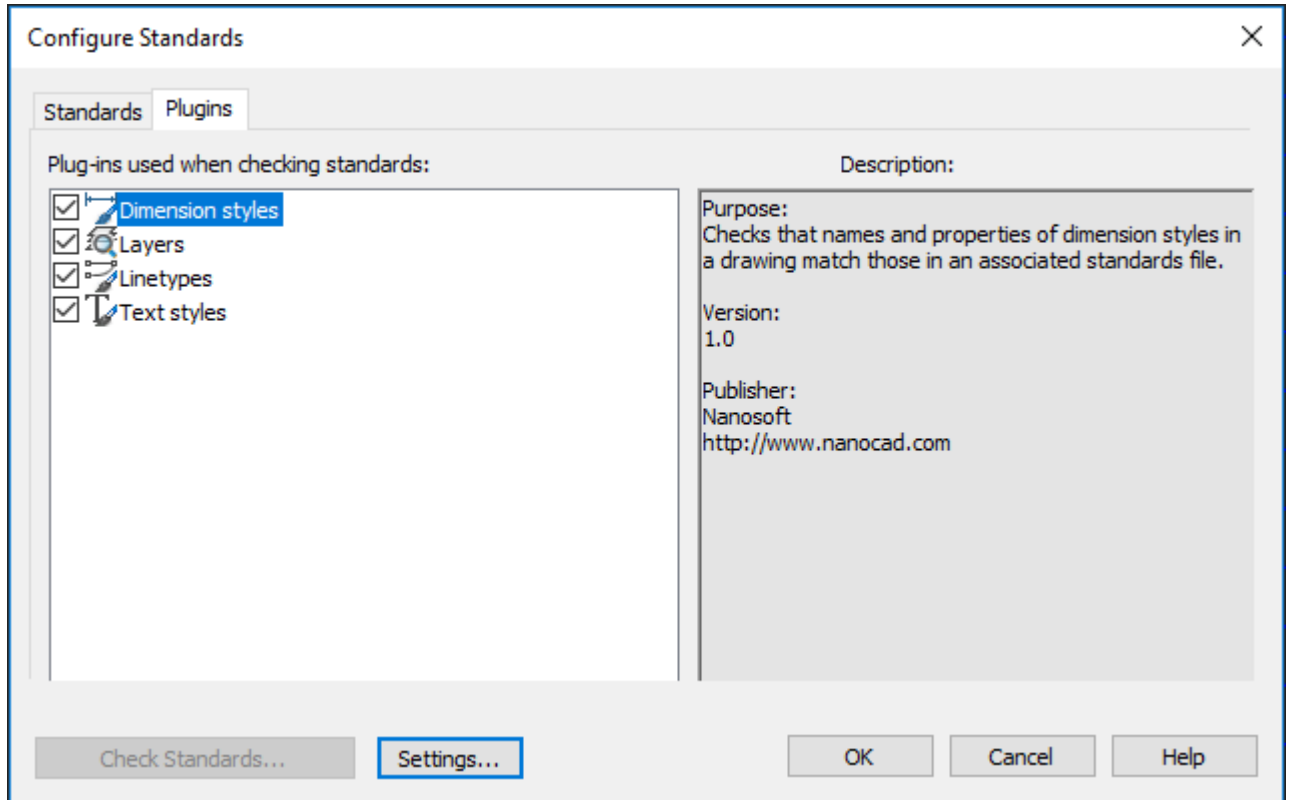

On this tab you can disable the existing checkers that are not required at the moment. For example, if you know that changes you make to a drawing concern only the text, to save time you can limit it to checking a drawing with the layer plug-ins and text styles plug-in, and disable the rest. By default, all plug-ins are used to check drawings for standards violations.

### Options

- Check...** Checks a document for standards violations.
- Settings...** Opens the **Check settings** dialog box.
- OK** Saves changes and closes the dialog box.
- Cancel** Closes the dialog box without saving changes.

## Checking Standards





Ribbon: **Manage – CAD Standards** >  **Check**



Menu: **Tools – CAD Standards** >  **Check...**

 Status bar:  **Check standards**

 Status bar: context menu of the button  **Check standards > Check...**

 Dialog **Standards Settings**: button **Check...**

 Command line: **CHECKSTANDARDS**

**NOTE:** The  **Standards audit** button is displayed in the status bar only if at least one standard file was associated with a drawing.

When checking a drawing for standards violations, the parameters of each named object of a specific type are checked against the corresponding parameters in the corresponding standards files. For example, parameters of each layer in the drawing are checked against the layers parameters specified in the standards file.

The check can be performed both manually and automatically (setting standard checking parameters).

After a warning message appears, you can make a choice: correct the violation or leave it unchanged:

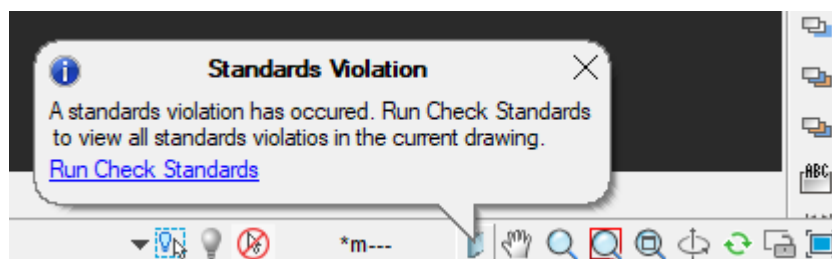
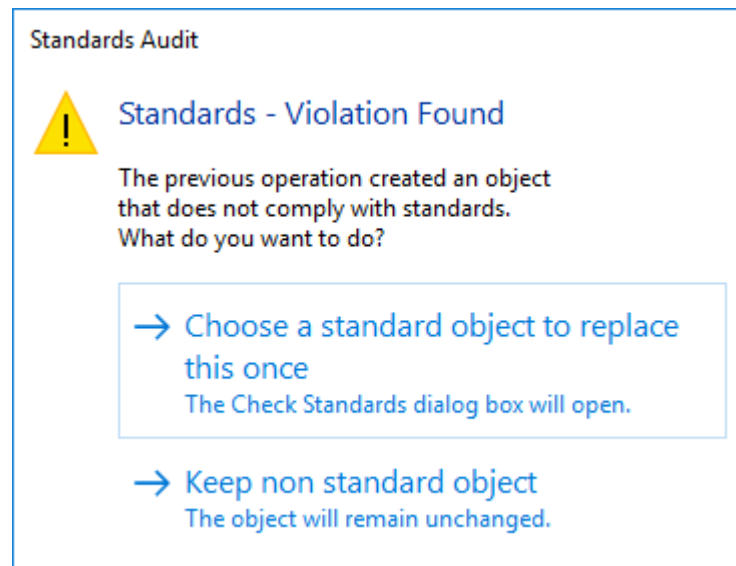

After the warning appears, you can choose to correct the violation or ignore it.

If you choose to fix the violation, the **Check** dialog box opens. If it is not required to fix the violation, select **Save non-standard object**, when the alert appears.

Each detected violation can be fixed or ignored. Information on each detected but not fixed standards violation is saved in the drawing. You can turn off the display of information on such ignored objects the next time you check the drawing.



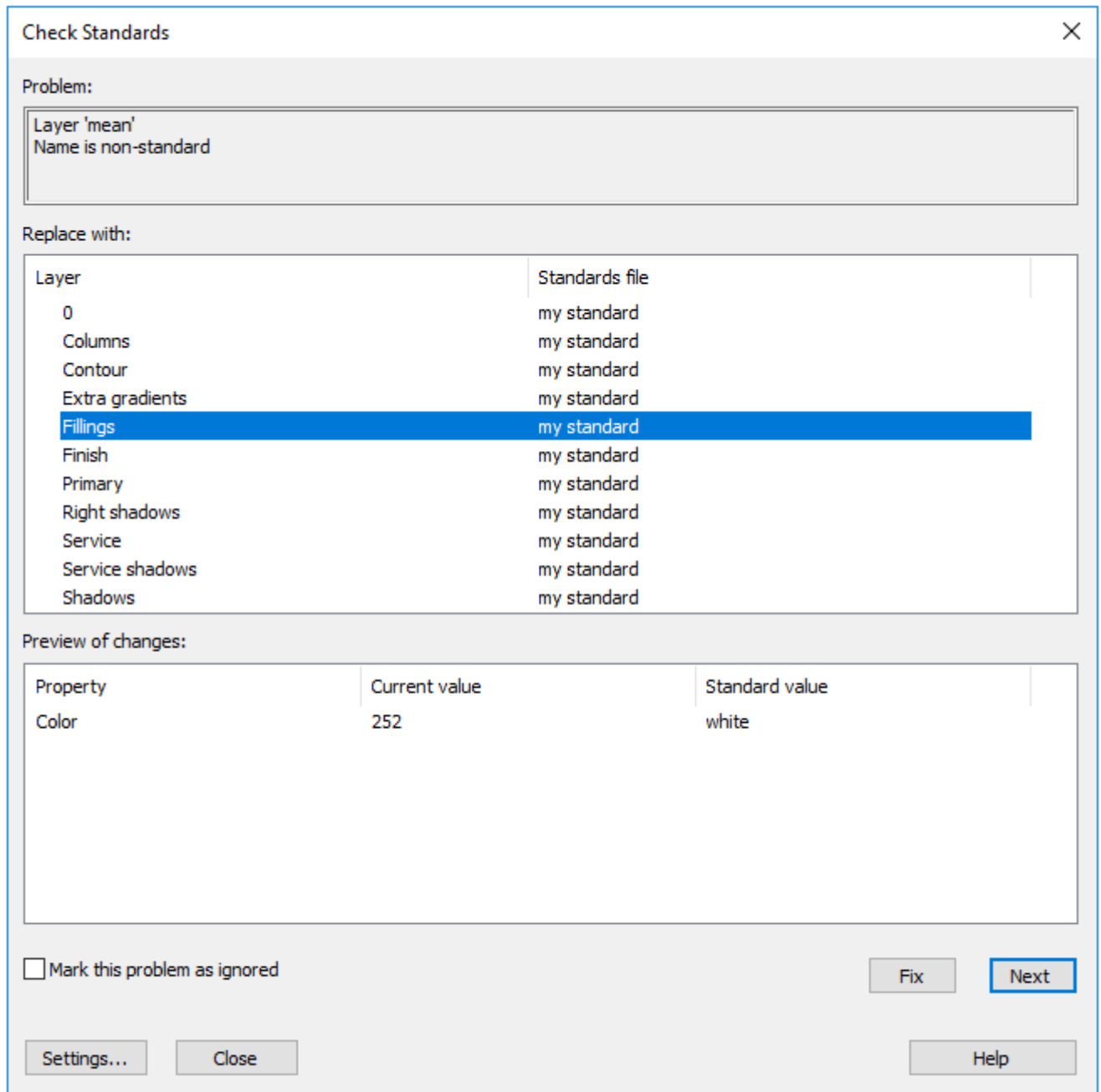

If there is no preferred fix option for the current standards violation, there will be no options highlighted in the **Replace with** list, and the **Fix** button is not available.

A check can uncover two types of errors:

- An object with a nonstandard name in the drawing being checked.  
For example, a layer named **Wall** is present in the drawing, but not found in any associated standards file.
- A named object with a standard name has nonstandard properties.  
For example, in the drawing the **Wall** layer has one color, while another color is specified in the standards file for the **Wall** layer.







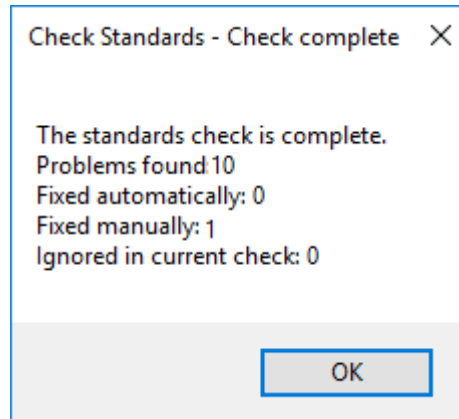

Detected elements with nonstandard names are purged from the drawing. All objects associated with the nonstandard element are associated with other element, which replaces that being purged. For example, when detecting a nonstandard layer **Wall**, it can be replaced with the standard layer **Arch-wall**. In this case, in the **Fix** mode of the **Check** dialog box all objects from the **Wall** layer are transferred to the **Arch-wall** layer, then the **Wall** layer is purged from the drawing.

If in the **Check** dialog box the **Mark this problem as ignored** is flagged for the detected violation, then notifications on detected violations related to this named object will not be displayed in future.

Once the entire drawing has been audited, the **Check complete** message is displayed; it reports all standards violations found in the drawing, as well as the details for violations: fixed automatically, fixed manually, ignored.



## Standards Check Options

-  Ribbon: **Manage – CAD Standards** >  **Standards Settings...**
-  Menu: **Tools – CAD Standards** >  **Check...**
-  Status bar: context menu of the button  **Check standards** > **Settings...**
-  Dialog box **Configure Standards**: button **Settings...**
-  Command line: **STANDARDSSETTINGS**

**NOTE:** The  **Standards audit** button is displayed in the status bar only if at least one standard file was associated with a drawing.

Dialog box for setting standards check.

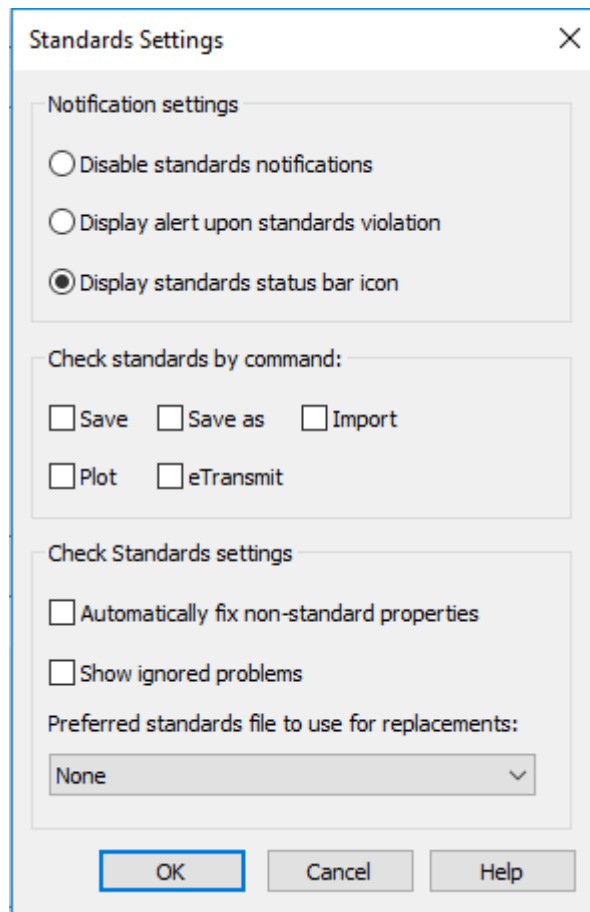

**Options:**

*Notification settings*

(system variable STANDARDSVIOLATION)

**Disable standards notifications**

Turns off notifications on standards violations and absence of standards files.

**Display alert upon standards violation**

Turns on notifications in finding standards violations while working on the drawing in form of pop-up box that proposes options.

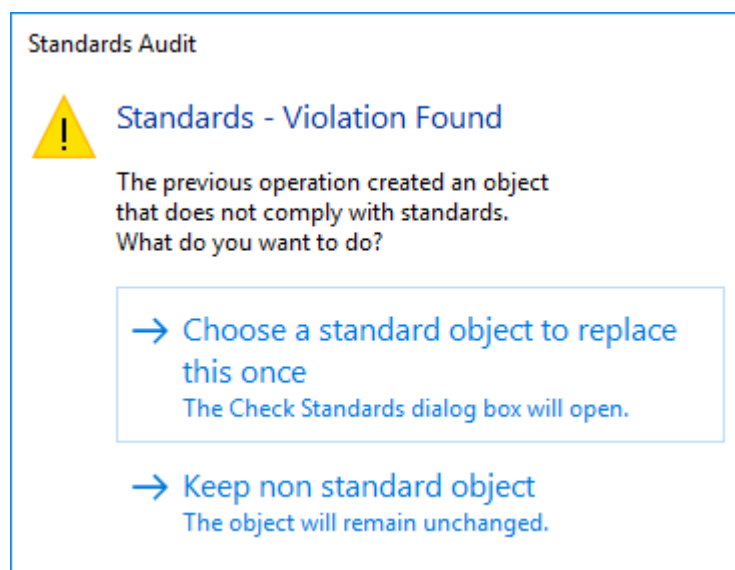

**Display standards status bar icon**

Turns on notifications in finding standards violations while working on the drawing through an icon in the status bar.

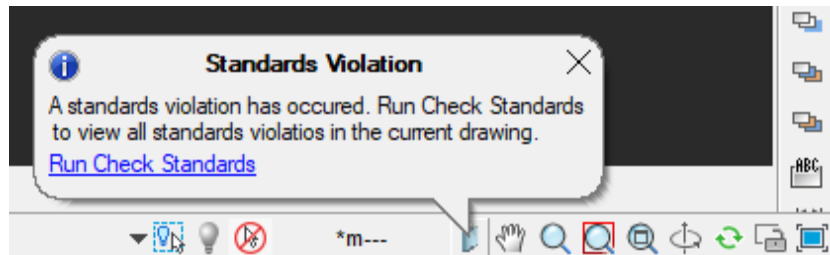

*Check standards by the command*

**Save, Save as, Import, Plot, eTransmit**

Selects the commands in performing which the standards should be checked for violations.

*Check options*

**Automatically fix nonstandard properties**

Manages the mode of automatic fix of nonstandard objects, if a more preferable replacement is available. Automatic replacement occurs only in cases when a nonstandard object has a name that matches the name of a standard object having different properties.

In this case, the properties of the standard object are assigned to the nonstandard object. After the check is completed the number of automatically fixed violations is displayed in the alert box.

**Show ignored problems**

If in the **Check** dialog box the **Mark this problem as ignored** is flagged for the detected violation, then notifications on this problem will still be displayed in future.

**Preferred to use for replacement**

The list of standards files which is the basis for default selection of a recommended fix in the **Replace with** list in the **Check** dialog box.

- If there is a recommended replacement (flagged in the **Replace with** list), then this recommended replacement is selected by default regardless of a file selected in this field.
- If no recommended replacement is found, and a standards file (DWS) is selected, the first replacement of the selected standards file is chosen.
- If **None** is selected for this option and a recommended replacement is absent, nothing is selected for replacement.

## Layer Translator

 Ribbon: **Manage – CAD Standards** >  **Layer Translator**

 Menu: **Tools – CAD Standards** >  **Layer Translator...**

 Toolbar: **CAD Standards** – 

 Command line: **LAYTRANS**

**Layer Translator** is intended for converting layers of the current drawing in accordance with the standards specified for layers.

You can also use the **Layer Translator** to visually control the contents of layers and to remove unused layers in a drawing.

The command opens the **Layer Translator** dialog box:

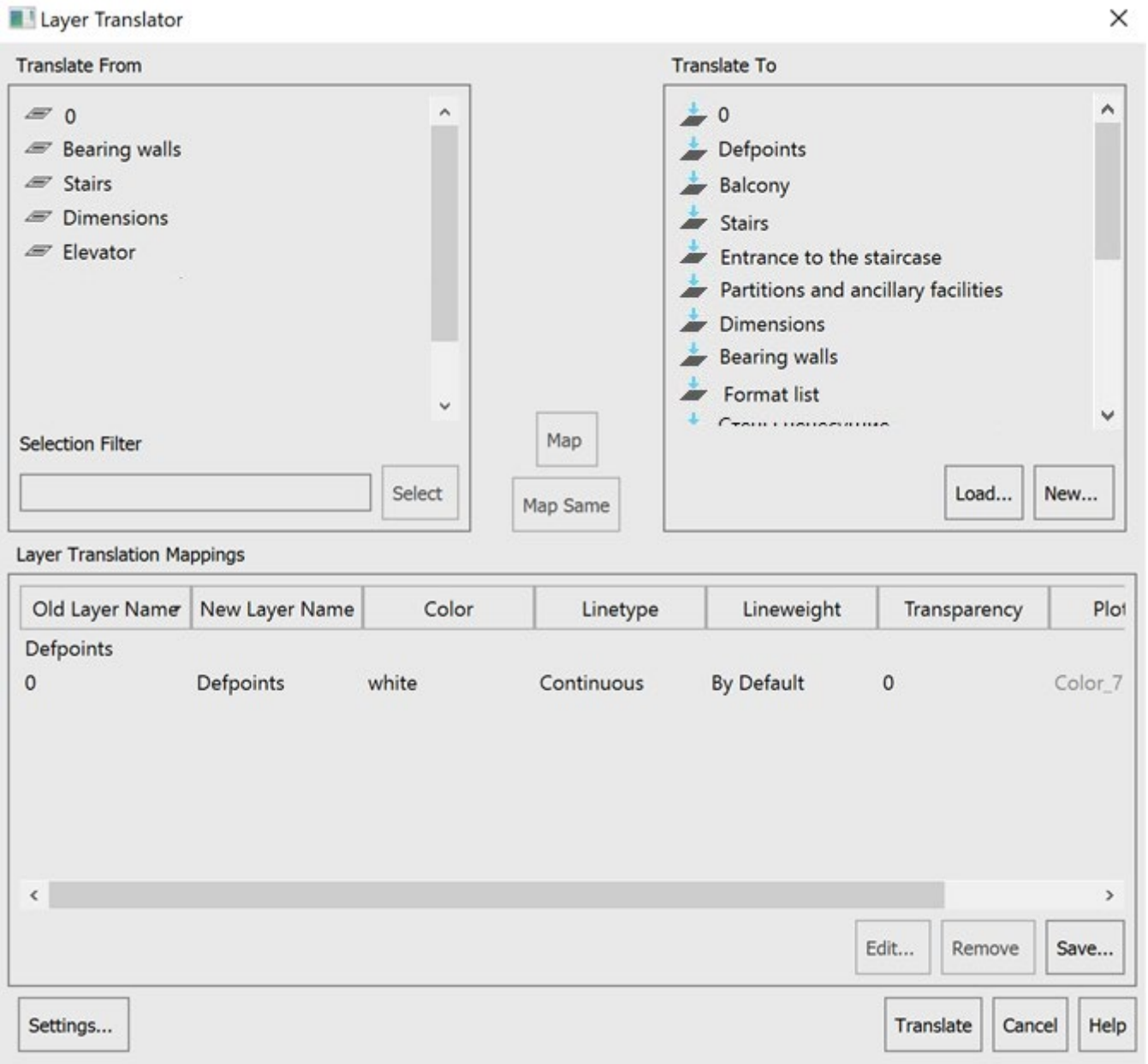

## Options

### Translate from

Selecting a layer to convert from the list of all layers in the current drawing.

To select several layers, press and hold the **SHIFT** key; to add any layer to the selection, select while holding down the **CTRL** key.

You can also add layers to your selection using the Selection Filter.

All layers in the list are selected using the **Select All** context menu command. The **Deselect All** command deselects all selected layers in the list.

To the left of the layer name there is an indicator of the content of objects on the layer:

 – used layer (or current layer);

 – the layer does not contain objects.

You can delete unused layers in the current drawing using the context menu **Delete unused** command.

### Selection Filter

Using a filter to select layers from the Translate from list. You can use special characters in the filter.

### Select

Adds filtered layers to the selected layers in the **Translate from** list.

### Translate to

Selects the layer whose standards will be used for conversion.

### Load...

Loading layers into the **Translate to** list from a drawing (\*.dwg), template (\*.dwt) or standards file (\*.dws).

If the downloaded file already contains a **Layer Translation Mappings** table (files created using the **Save...** button), then this information will be displayed in the **Layer Translator** window.

You can load layers from multiple files into one drawing.

When loading files with same name layers, the layer loaded first is included in the **Translate to** list. Likewise, the loading of a mapping table element is canceled if it matches one in the drawing.

### New...

Creates a new layer in the **Translate to** list.

If you select a layer in the **Translate to** list before clicking the button, the properties of that layer will be used by default for the new layer.

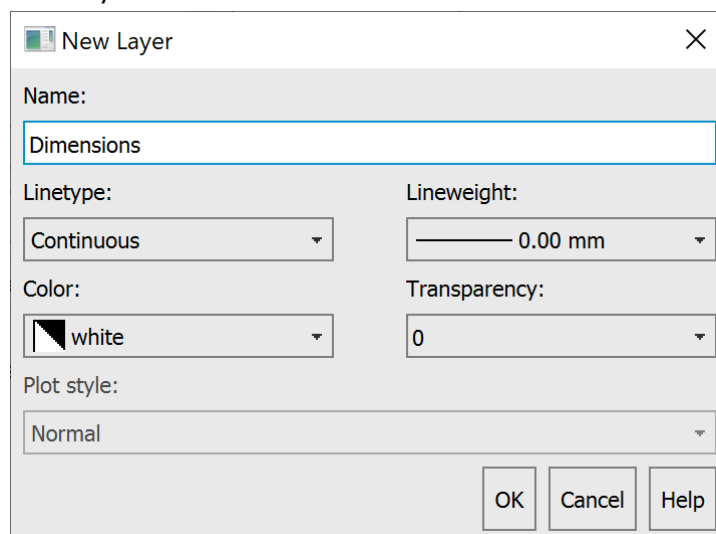

The name of the new layer should not coincide with existing ones in the **Translate to** list. The following symbols are not allowed in the name: <>/ \'"':;?\*|,= `.

*Map*

Matches layers from the **Translate from** and **Translate to** list and adds them to the **Layer Translation Mappings** table. Adding is also done by double-clicking on a layer (from or to).

*Map same*

Matching layers that have the same names.

*Layer Translation Mappings*

A tabular preview of the list of layers to be converted and the list of properties they will receive: **New Layer Name, Color, Linetype, Lineweight, Transparency, and Plot Style.**

Double-clicking the left mouse button on the column title separator automatically changes the width of the columns.

You can edit the properties of the destination layer in the **Edit Layer** dialog box.

**Edit...**

Opens the **Edit Layer** dialog box, where you can change the properties of the destination layer: **Color, Linetype, Lineweight, Transparency, Plot style.**

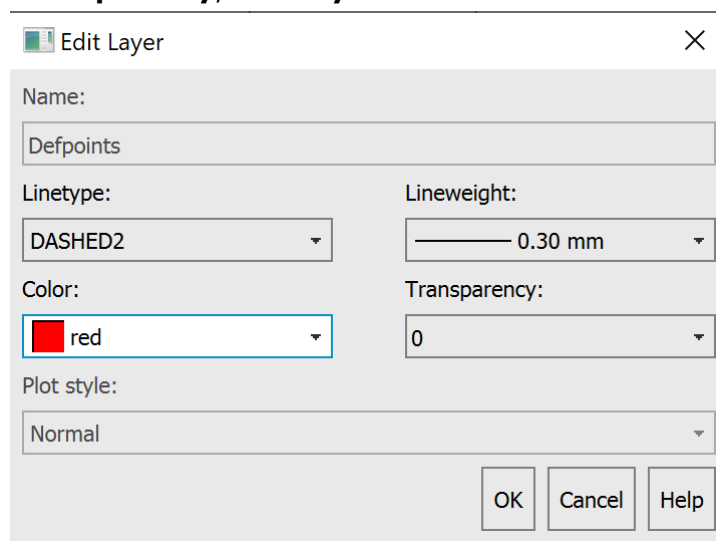

You can also open the **Edit Layer** dialog box in the **Layer Translation Mappings** table by double-clicking on the mapping or by using the **Edit** context menu command.

**Remove**

Removes the selected mapping from the **Layer Translation Mappings** table.

You can delete all mappings at once using the **Delete All** context menu command.

**Save...**

Saves the current layer mapping table in a separate file for later use. Layer mappings are saved in a \*.dwg or \*.dws file format. The layer translator creates layers in a file and writes mapping information to each of them.

*Settings...*

Opens the **Settings** dialog box, where you can configure layers translation.

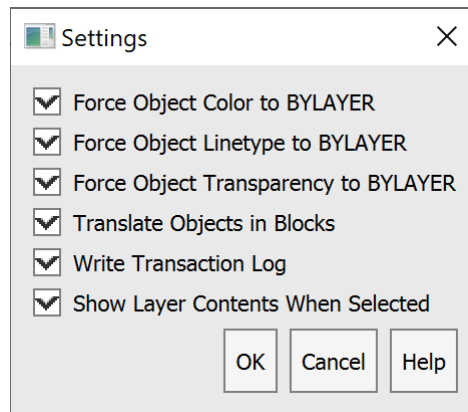

**Force Object Color to BYLAYER**

Configures the color of objects when translating layers. Applicable for objects that have **Color** set other than **By Layer**. When the box is checked, the color of such objects will change to **By layer**; when the box is unchecked, the color of the objects will remain unchanged.

**Force Object Linetype to BYLAYER**

Configures the linetype of objects when translating layers. Applicable for objects that have a **Linetype** set other than **By Layer**. When the box is checked, the linetype of such objects will change to **By Layer**; when the box is unchecked, the linetype of the objects will remain unchanged.

**Force Object Transparency to BYLAYER**

Configures the transparency of objects when converting layers. Applicable for objects that have **Transparency** set other than **By Layer**. When the box is checked, the transparency of such objects will change to **By Layer**; when the box is unchecked, the transparency of the objects will remain unchanged.

**Translate Objects in Blocks**

Enables/disables the mode of translating objects in blocks. When the box is checked, objects in blocks participate in the transformation of layers; when the box is unchecked, objects in blocks remain unchanged on the original layers.

**Write Transaction Log**

Enables/disables the mode of recording translation results in the transaction log. A file with the drawing name and \*.log extension is created in the folder where the source drawing is located.

**Show Layer Contents When Selected**

Enables/disables view mode for selected layers in the graphics area of the drawing. You can select a layer from the Source Layers list and from the Layer Mapping Table. When unchecked, all layers in the drawing are displayed. You can select a layer from the **Translate from** list and from the Layer Translation Mappings table. When unchecked, all layers in the drawing are displayed.



## Translate

Starts the layer translation process based on the specified mappings. If the current layer mapping table has not been saved (**Save...** button), a warning message will appear:

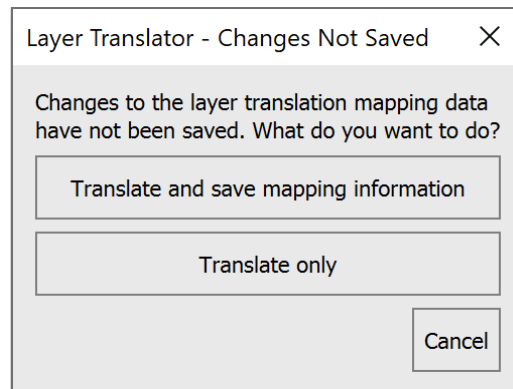

The translation is performed on all specified layers, including invisible, frozen, and locked layers. When translating layers, the service layers 0 and Defpoints and the layer assigned to the current layer are not deleted.

### *To translate drawing layers according to specified standards:*

1. Run the command.
2. In the **Translate from** list, select the layers to translate. If necessary, use the **Selection Filter**.
3. Click the **Load...** button to load destination layers from a drawing, template, or standards file. Or click the **New...** button to create a new destination layer. In the **Translate to** list, select the layer whose standards will be used for translation.
4. Click the **Map** button and check the data in the **Layer Translation Mappings** table. If necessary, repeat the layer selection to set other mappings.  
 To map layers with the same names, use the **Map Same** button.  
 To edit destination layers, click the **Edit...** button or select the **Edit** context menu command.  
 To remove mappings from the table, click the **Remove** button or use the **Delete, Delete all** context menu commands.
5. If necessary, click the **Save...** button to save the mappings.
6. Click the **Settings...** button and select layer translation settings.
7. Click the **Translate** button to start the process of translating drawing layers in accordance with the specified standards.

### *To delete unused layers in the current drawing:*

1. Run the command.
2. Call the context menu with the right mouse button on the **Translate from** list.
3. Select the **Delete unused** command.

### *To visually control the contents of layers in the graphics area of a drawing:*

1. Run the command.
2. Click the **Settings...** button.

3. Check the **Show Layer Contents When Selected** box. Click **OK**.
4. Select a layer to view in the drawing graphics area from the **Translate from** list or from the **Layer Translation Mappings** table.

## Utilities

Errors and damage can occur in document files due to disruptions in power supply, malfunctions of computer hardware, program crashes, transfer of documents on electronic media and transferring over the network etc.

Utilities find and correct errors and damage in problem files as far as possible. Full recovery of data is not guaranteed.

Purging of a document allows deletion of unused elements from the finished document to reduce document size.

### Document Audit



**nanoCAD button – Utilities >  Audit**



**Menu: File – Drawing Utilities >  Audit**



**Document tab context menu: Drawing Utilities >  Audit**



**Command line: **AUDIT****

The command allows auditing of an opened document in nanoCAD for errors and correcting some of them. If a document cannot be opened due to damage, use the **Recover** command.

Correction of all errors is not guaranteed.

After starting the command, in the inquiry *Do you want to fix errors? Or [Yes/No]:* select **Yes**.

Audit report is shown in the command line and looks like:







```
AcDbLine(117689). Error:: Inactive Xdata handle (1157FE) was found.  
Audit: Invalid.  
Fixed:: Replaced: Set to Null.
```

```
AcDbArc(11768A). Error:: Inactive Xdata handle (1157FE) was found.  
Audit: Invalid.  
Fixed:: Replaced: Set to Null.
```

```
AcDbCircle(119E1F). Error:: Inactive Z coordinate – 1e+100 was found.  
Audit: Invalid.  
Fixed:: Replaced: Set to 0.
```

For more convenient viewing of the protocol at the end of the check, you can call up a text window by pressing the **F2** key .

## Auditing Geometry

-  nanoCAD button – Utilities >  **Audit Geometry**
-  Menu: **File – Drawing Utilities** >  **Audit Geometry**
-  Context menu of document tab: **Drawing Utilities** >  **Audit Geometry**
-  Command line: **AUDITGEOMETRY**

The command is intended to identify and fix problematic drawing objects located outside the range **1e+20** along **Z** axis.

The command ensures correction of Z-coordinates for objects located on frozen, locked and disabled layers.

The first opening of a file is accompanied by an automatic check of objects geometry. When geometry errors are found, a dialog is displayed with a message and a choice of action

- Fix** - immediately run the **Audit Geometry** command to fix errors.
- Cancel** - open the file without correcting errors.

If errors are not fixed, when files are opened again (after re-saving), the geometry audit is started by the command manually.

**NOTE:** Hatch audit is not performed in an automatic mode. To find and fix problematic hatches, it is necessary to run the audit manually.

### Audit modes:

<u>Audit Z coordinates</u>	Auditing Z-coordinates of all objects in a drawing.
<u>Audit Hatches</u>	Auditing the correct display of hatches within the boundaries of contours.

### Audit Z coordinates

#### Audit options:

Yes(fix_errors)	Fixes the errors found.
Yes(fix_and_log_errors)	Fixes errors and generate report on found and fixed errors.
No	Does not fix errors.
No(only_log_errors)	Creates a report on detected errors without fixing them.

Detected and fixed errors are reported in the **Geometry audit log** dialog

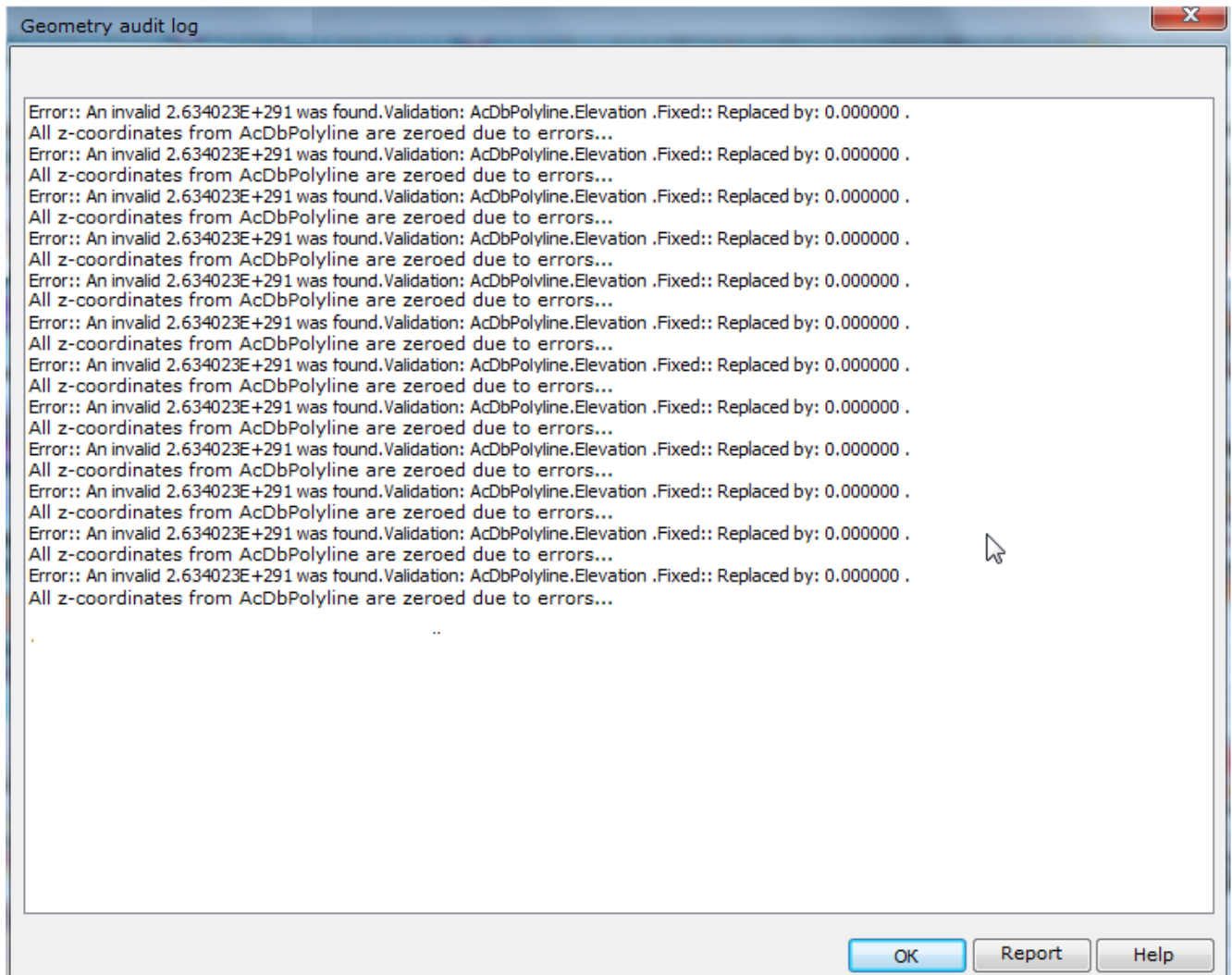

By clicking the **Log** dialog button, you can save the log information to a separate file. By default, the Log file is saved in a drawing folder and assigned with the drawing file name with \*.log extension.

When saving reports of consecutive audits of Z coordinates and hatches for one drawing, 2 log files will be created:

- first - *File name.log*;
- second with adding the index - *File name\_1.log*.

### Command prompts:

```
Select audit type
[audit_Z_coordinates/Audit_hatches]
```

```
Do you want to fix errors?
[Yes(fix_errors)/Yes(fix_and_log_errros)/No/No(only_log_errros)]
```

Select Audit Z coordinates mode.

Select the required audit option.

### Audit Hatches

```
Select audit type
[audit_Z_coordinates/audit_Hatches/]
```

Select Audit hatches mode.

Audit logs are displayed in the command line.

## Recovery of Document

 nanoCAD button – Utilities >  **Recover**

 Menu: **File – Drawing Utilities** >  **Recover**

 Command line: **RECOVER**

The command allows recover a document that cannot be opened.

Full recovery and correction of all errors are not guaranteed.

After command launch, a standard dialog box to open a file appears, you have to select the folder and the name of the damaged file and after that click the **Open** button.

The report is shown in the command line and is similar to the report of the **Audit** command:

```
AcDbLine(117689). Error:: Inactive XData handle (1157FE) was found.  
Audit: Invalid.  
Fixed:: Replaced: Set to Null.
```

```
AcDbArc(11768A). Error:: Inactive XData handle (1157FE) was found.  
Audit: Invalid.  
Fixed:: Replaced: Set to Null.
```



```
AcDbCircle(119E1F). Error:: Inactive Z coordinate - 1e+100 was found.  
Audit: Invalid.  
Fixed:: Replaced: Set to 0.
```

For more convenient viewing of the protocol at the end of the check, you can call up a text window by pressing the **F2** key .

## Purging of Document

 nanoCAD button – Utilities >  **Purge**

 Menu: **File – Drawing Utilities** >  **Purge ...**

 Document tab context menu: **Utilities** >  **Purge...**

 Command line: **PURGE, PU**

This command is used to purge unused named elements from a document: block descriptions, dimension styles, layers, text styles and line types.

Using this procedure, you can reduce file size after finishing your project.

**ATTENTION!** Deleted elements cannot be recovered.

The **Purge** dialog box appears after the command is launched. There is a list of elements which available for deletion, and a list of elements which are not available for deletion. The list is organized as a tree: to open a list of elements of one type, click twice on the elements name or select the **+** sign to the left of the name. If there is no **+** sign, it means that there are no elements of this type to delete (or which cannot be deleted).

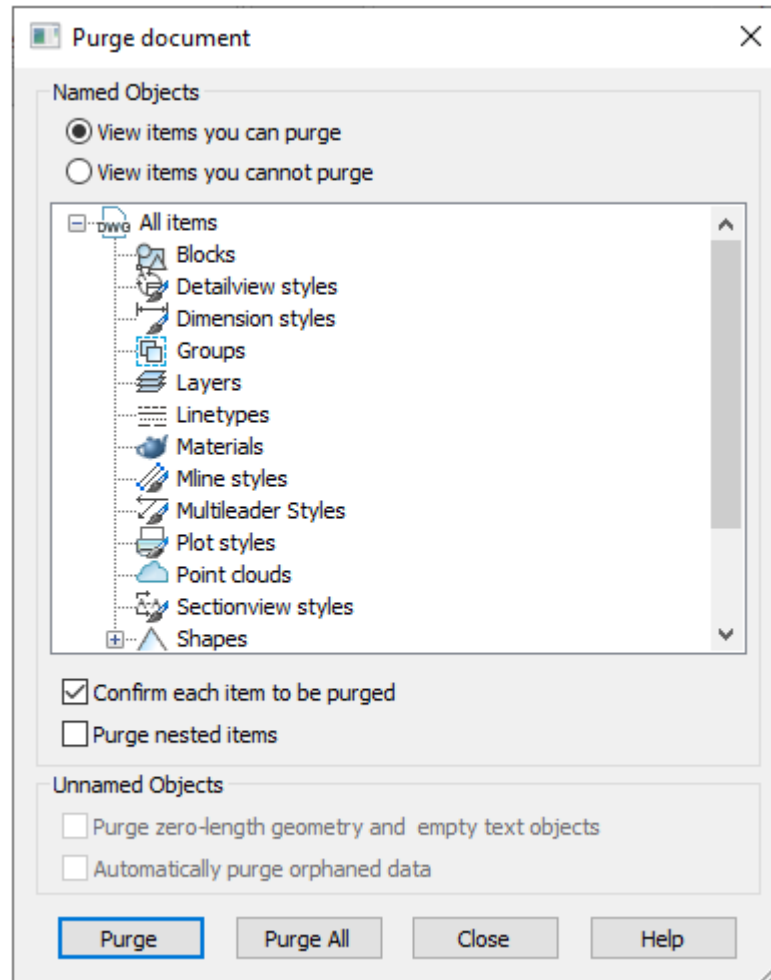

**Parameters:**

**View elements you can purge**

Switches on the mode for viewing elements which can be deleted from a document.

**View elements you cannot purge**

Switches on the mode for viewing elements which cannot be deleted from a document. Elements, used in a document or standard items which cannot be deleted.

**Confirm each item to be purged**

Switches on the mode for displaying a query to confirm for each purged element. For further purge in an automatic mode, at any moment you can click **Yes to all** in a query box.

**Purge nested items**

Switches on the mode for purging all unused named objects contained inside other unused named objects. The purge is confirmed in a separate dialog box.

**Purge zero-length geometry and empty text objects**

Switches on the mode for purging graphical waste. The checkbox is not available in case such geometry is absent in a document.

## Automatically purge orphaned data

Purges outdated vector data styles of DGN format.

### Buttons:

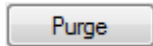

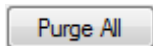

Purges the selected elements.

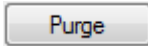

Purges all elements from the list.

### To delete elements with confirmation:

1. Switch on the Confirm each item to be purged mode.
2. Select the  or  button.
3. In the opened dialog box confirm purging of the elements:

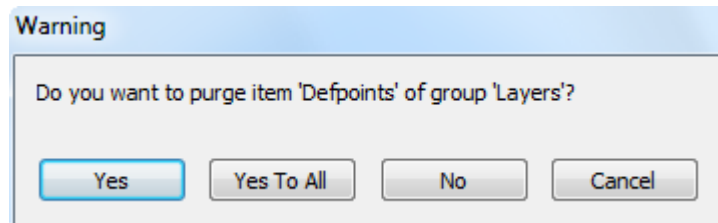

### Buttons:

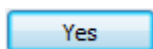

Confirmation for every selected element.

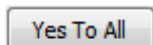

Confirmation for all elements.

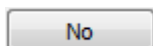

Refusal to delete the selected element.

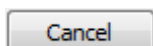

Cancels the purge command.

## Purging a Document Using the Command Line



Command line: **-PURGE, -PU**

The version of the PURGE command to work from the command line. Contains expanded purging abilities.

### Command options:

<u>B</u> locks	<a href="#">Block definitions.</a>
<u>D</u> etailviewsty <u>l</u> es	Detail view styles.
<u>D</u> imstyles	<a href="#">Dimension styles.</a>
<u>G</u> roups	<a href="#">Groups.</a>
<u>L</u> Ayers	<a href="#">Layers.</a>
<u>L</u> Types	<a href="#">Line types.</a>
<u>M</u> aterials	<a href="#">Materials.</a>

<u>MULTileaderst yles</u>	<a href="#">Multileader styles.</a>
<u>Plotstyles</u>	<a href="#">Plot styles.</a>
<u>SShapes</u>	<a href="#">Shapes.</a>
<u>textSTyles</u>	<a href="#">Text styles.</a>
<u>Mlinestyles</u>	<a href="#">Multiline styles.</a>
<u>SEctionviewst yles</u>	Section view styles.
<u>Tablestyles</u>	<a href="#">Table styles.</a>
<u>visualstyles</u>	visual styles.
<u>Regapps</u>	<a href="#">Registered applications.</a>
<u>Zero- length geomet ry</u>	Zero-length geometry.
<u>Empty text ob jects</u>	Empty text objects.
<u>Orphaned data</u>	Unused line style data from *.dgn format.
<u>ANnotscales</u>	<a href="#">A nnotative scales.</a>
<u>Point clouds</u>	<a href="#">Point clouds.</a>
<u>sortTTable</u>	Purging the sorting table, which contains lists of objects ordering (DRAWORDER). Sometimes, there are so many such records that the program starts working with the document much slower. Purging of this list removes empty entries, greatly speeding up your work.
<u>Full</u>	Automatic full purge of a document. Including the purge of objects having zero-length geometry, empty text objects, annotative scales and registered applications.
<u>All</u>	Purging unused objects of the same nesting level. Objects having zero-length geometry and empty text objects are not purged.

*Command prompts:*

Enter type of unused objects to purge  
[Blocks/Detailviewstyles/Dimstyles/Groups/Layers/LTypes/Materials/MULTileaderstyles/Plotstyles/SHapes/textSTyles/Mlinestyles/SEctionviewstyles/Tablestyles/Visualstyles/Regapps/Zero-length\_geometry/Empy\_text\_objects/Orphaned\_data/ANnotscales/Point\_clouds/Full/All]:

Enter name(s) to purge <\*>:

Verify each name to be purged? [Yes/No] <Yes>:

Select the type of objects to purge, press **ENTER**.

Enter names to purge or press **ENTER** to search for all elements of selected type.

To confirm purging of each element, select Yes.

When opening documents, a check is made to see the need to purge a number of elements. Depending on the result of the check, various warning messages may be displayed in the command line, for example:





The utility helps fix the problems when texts and object names are replaced by garbled symbols, characters or hieroglyphs associated with incorrect recognition of the text code page.

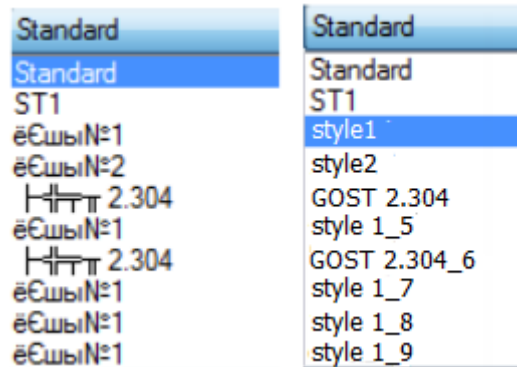

The command opens the **Text Decoder** dialog box.

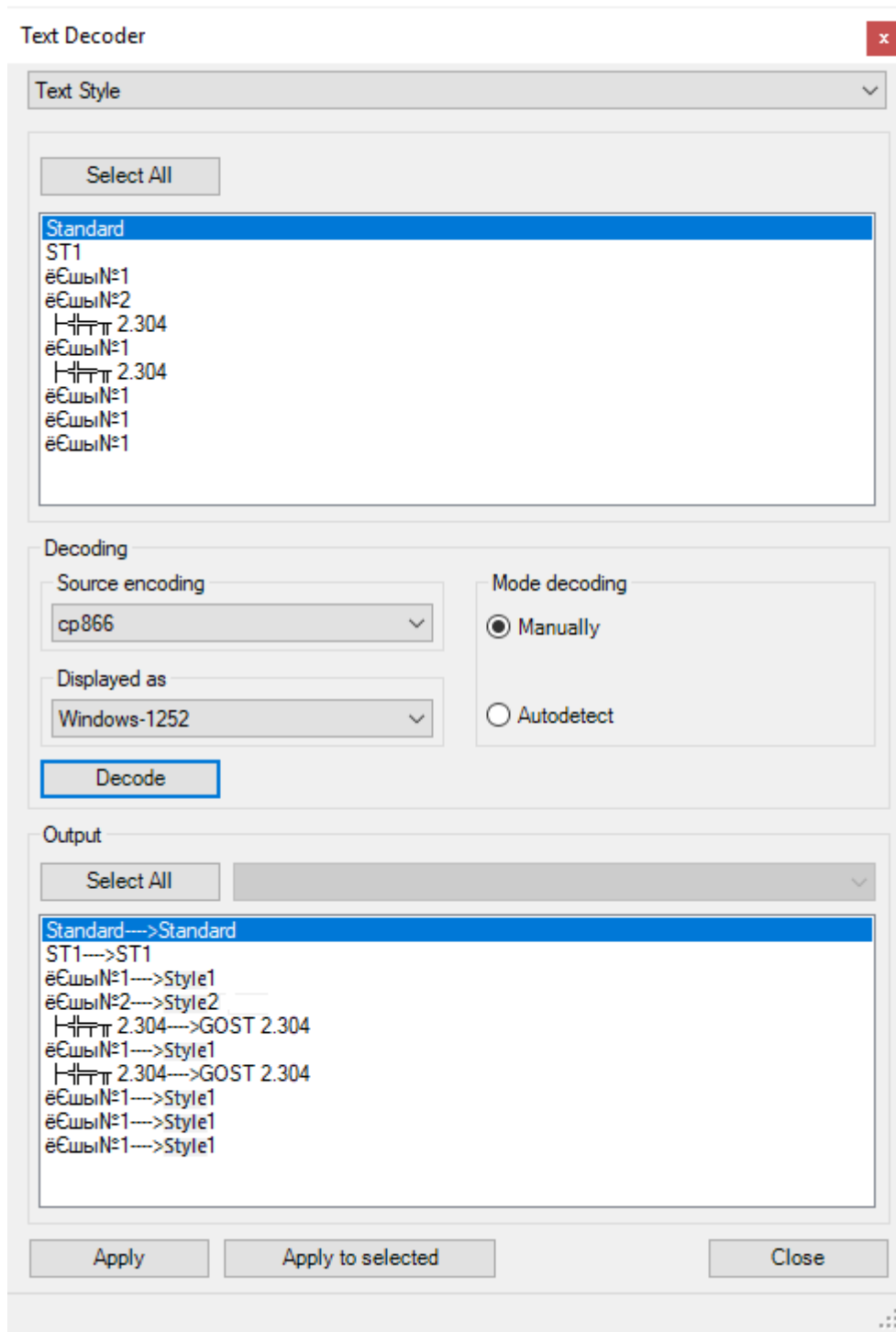

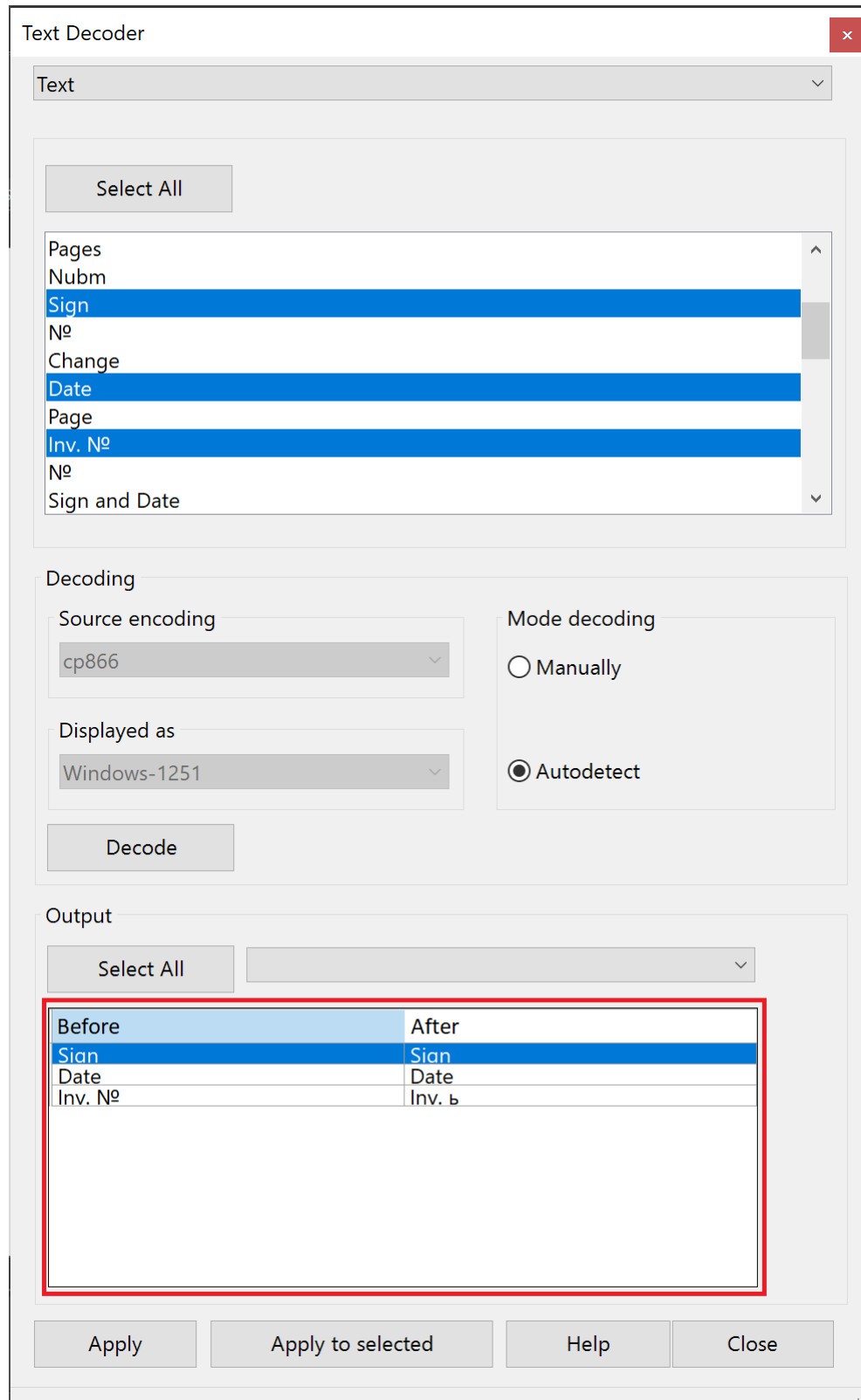

### Options

#### Select

Selects from the list of drawing elements that contain named objects and texts. Named objects of the selected element are displayed in the section window.

#### Select all

Selects all named objects displayed in the section window. A random selection of objects for conversion can be made by using **CTRL** and **SHIFT** keys.

### Decoding

<b>Source encoding</b>	Selection of supposed type of source encoding from the list.
<b>Displayed as</b>	Selection of supposed type of target encoding from the list.

### Decoding modes

<b>Manually</b>	The mode of manual encoding selection.
<b>Autodetect</b>	Automatic encoding selection.
<b>Decode</b>	Starts the decoding procedure.

### Decoding output

<b>Select all</b>	Selects all decoding results displayed in the section window. A random selection of objects for encoding conversion can be made by using <b>CTRL</b> and <b>SHIFT</b> keys. On the right there is a list of possible decoding options.
<b>Before-After Table</b>	View decoding results as a table, with the possibility to sort columns alphabetically.
<b>Apply</b>	Applies all decoding results.
<b>Apply to selected</b>	Applies the conversion results to selected elements.

### Encoding conversion procedure

1. Open the **Selection** list, select the named object or text that requires conversion.
2. Select the necessary from the elements displayed in the section window or click **Select all** button to select all elements.
3. Set the decoding mode:

#### Manually:

- Select the encoding type from the **Source encoding** list.
- Select the encoding type from the **Displayed as** list.

**Autodetect** – the source and target encodings are selected automatically. The corresponding lists will be disabled.

4. Click **Decode**.

### Applying the decoding results

The decoding results are displayed in the section window after the separating characters →>.

If conversion is made in the **Autodetect** mode, the list of decoding options becomes available for the element selected in the box.

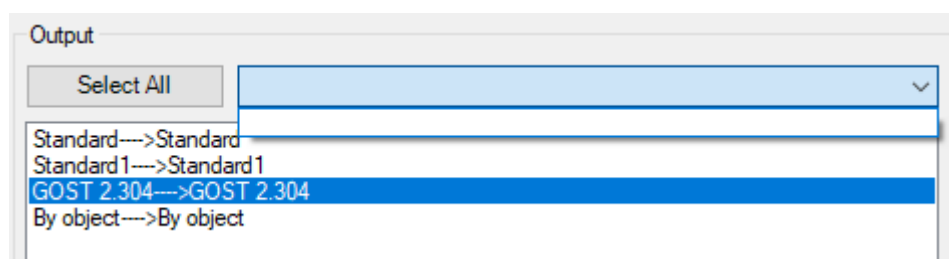

When using **Manually** mode, the desired result can be achieved by changing types of source and target encodings.

1. Select the elements with the correct decoding result in the section window.
2. Click **Apply to selected button**.

- If all encoding conversion results are acceptable, click **Select all** button and **Apply** button.

## Batch File Processing

 nanoCAD button – Utilities >  **Batch File Processing**

 Menu: **File – Drawing Utilities** >  **Batch File Processing...**





 Command line: **BATCHPROCESS**

The command is intended for applying the purge and audit commands to a batch of files.

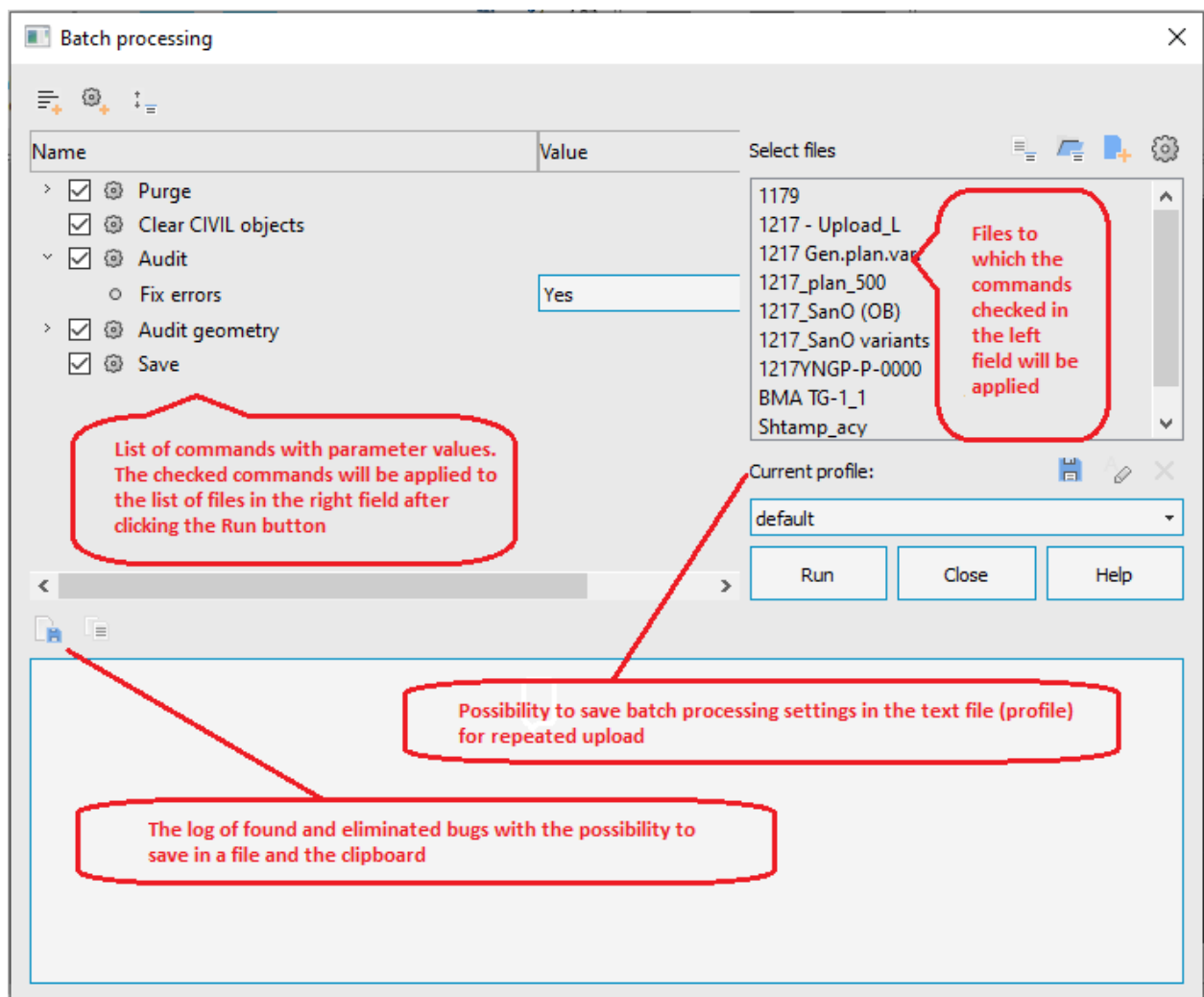
It is available to apply commands for purging files (PURGE), auditing files (AUDIT), auditing geometry (AUDITGEOMETRY) and clearing Civil3D objects.

Upon running the command, the **Batch processing** dialog box opens.



The right field displays a list of files selected for processing. You can add files one by one using the  **Browse file**, or as a whole folder using the  **Browse folder** button. The  **Use current drawing** button adds the current document to the list. In the **Settings** , you can specify the search in subfolders.

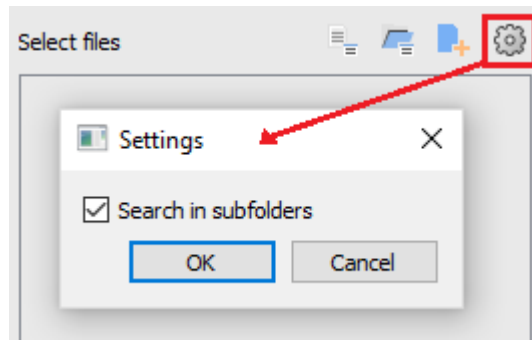

The left part of the **Batch processing** window contains a list of commands available for applying with a list of parameters. The flags mark the actions to be performed for each file from the list in the right part of the window. To add a new command manually, you can use the  **Add command** button.

To change the order of commands, click the  button and in the window that opens change the commands order by drag and drop.

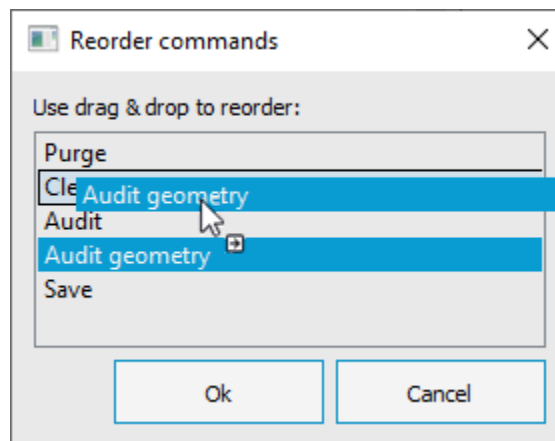

Purge is also performed on disabled, frozen and blocked layers.

It is possible to purge all categories presented in the non-dialog version of the **Purge** command (-PURGE), including: empty entries in the sort table, annotative scales, registered applications.

In addition to the standard features of the -PURGE command, batch processing implements the possibility to purge external reference files (the **Purge xrefs** checkbox).

For example, if there are problematic files with annotative scales, you need to purge all external references at once to get rid of these scales.

The Batch purge automatically opens xref files and cleans them up. And then updates all external references.

Batch processing settings can be saved  to a new settings profile for later use.

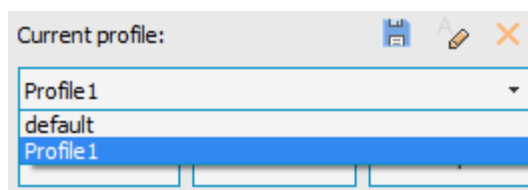

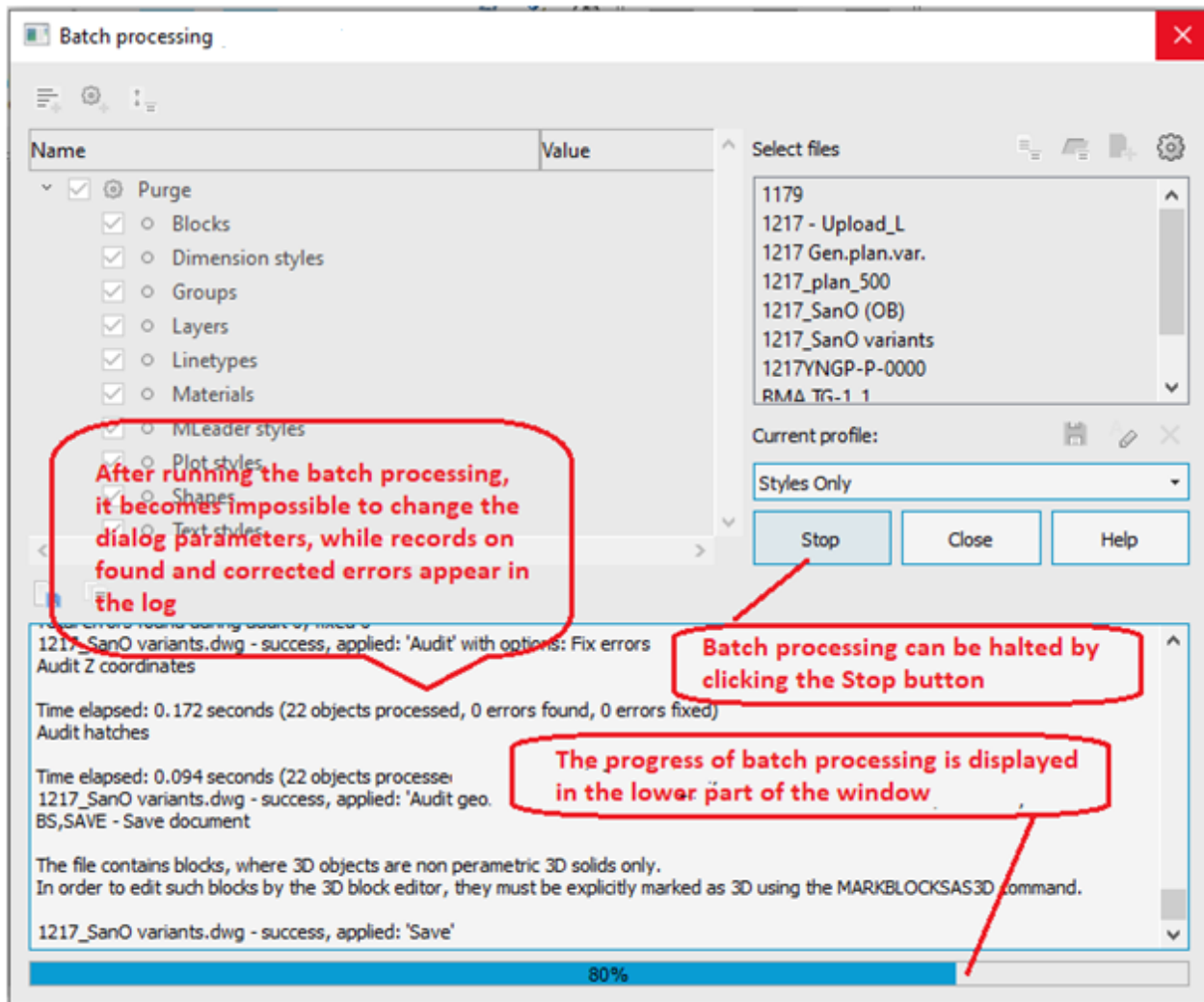

You can create a new profile with a clean list of commands using the  **New script** button.

The batch processing is started with the **Start** button.



Messages about found and fixed problems are displayed in the central field.

Batch processing can be halted by the **Stop** button.

After the audit is completed, the final report can be copied to the clipboard  or saved to a separate  file.

## File Explorer

 Ribbon: **Manage – Palettes** >  **File explorer**

 Menu: **Tools** –  **File Explorer**

 Menu: **View – Toolbars – Functional** –  **FileExplorer**

 Toolbar: **Main** – 

 Command line: **FILEEXPLORER, ADCENTER**

**File Explorer** is association of Windows explorer and drawing definition table. Drawing definition table is tables of layers, layouts, external references, block definitions, linetypes, text styles, and dimension styles.

File explorer displays only the following files:



- drawing files – dwg, dxf, dwt;
- underlay files – dwf, dwfx, pdf;
- raster image files – jpg, jpeg, png, bmp, pcx, tiff.





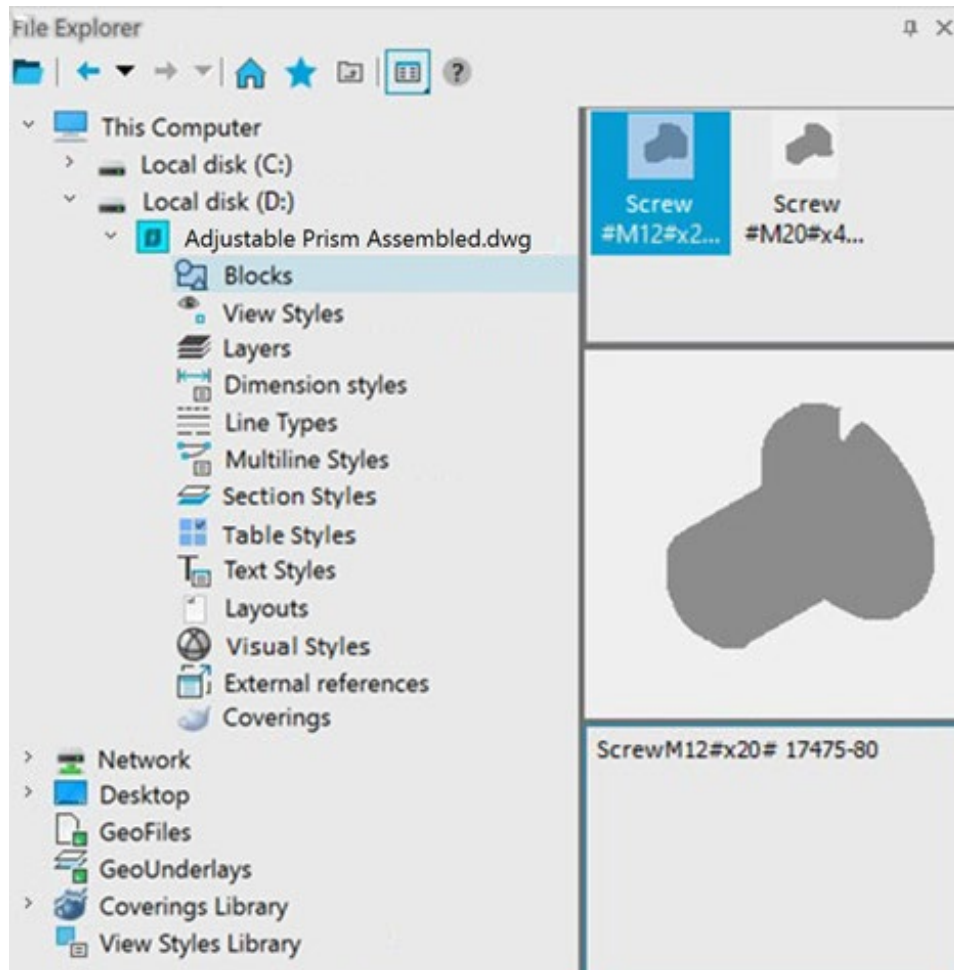

File explorer not display files with other types.

**NOTE:** File explorer need more horizontal area than other functional toolbars.



The File Explorer window has a built-in toolbar located below the window title.

**Toolbar button:**

-  Selects a file in the tree, but using the **Open** dialog box.
-  Moves to the previous state of the window.
-  Moves to the next state of the window (according to the list of previously made transitions).
-  Moves to the folder marked as primary (home).
-  Moves to the **Favorites** folder.
-  Moves up one level in the tree.
-  Menu to set up the list display in the right area of the window (**Large icons, Small icons, List, Details**).

The central part of the window is a moving vertical line (splitter) divided into two parts. Left part (**Folders**) displays folders tree of current user. Right part displays content of selected tree node. Right part divided into three parts: full list of elements, description of selected element and image of selected element. Every element type has own icon.

Right part of dialog box shows the following elements: Folder, Drawing file, Underlay file, Raster image file, definitions table (Layers, Blocks, Text styles, Linetypes, Dimstyles, Layouts, XRefs), named object (Layer, Block definition, Text style, Linetype, Dimstyle, Layout, XRef).

## Actions

Actions on elements from the right part of File Explorer: Drag&drop, double click, right click. Sometimes multiple preselection is available (with **SHIFT** and **CTRL**).











This makes it easy to copy definition table elements from one drawing to another

*Drag and drop is used for the following elements:*



Type of element	Effect
Blocks (📁)	Copy block definition to the current drawing. Multiple selection is available. Does not copy if block with the same name exists in current drawing.
Visual Style (🎨)	The visual style is copied to the current drawing. If a style with the same name already exists in the current drawing, it is not copied.
Dimstyles (📏)	Copy dimension style to the current drawing. Multiple selection is available. Does not copy if dimstyle with the same name exists in current drawing.
Layers (📁)	Copy layer to the current drawing. Multiple selection is available. Does not copy if layer with the same name exists in current drawing.
Multileader style (📏)	The multileader style is copied to the current drawing. If a style with the same name already exists in the current drawing, it is not copied.
Table Style (📄)	The table style is copied to the current drawing. If a style with the same name already exists in the current drawing, it is not copied.
Textstyles (T)	Copy text style to the current drawing. Multiple selection of styles is available. Does not copy if text style with the same name exists in current drawing.
Linetypes (📏)	Copy line type to the current drawing. Multiple selection is available. Does not copy if line type with the same name exists in current drawing.
Material (🌐)	The Material is copied to the current drawing. Multiple choice of materials is possible. The new Materials appear in the <b>Materials Browser</b> . If a Material with the same name already exists in the current drawing, it is not copied.











*Double click is used for the following elements:*

Type of element	Effect
Folder (📁)	Transition into the folder.
Drawing file (📄)	Open list of named objects definitions.
Underlay file (📄)	Open the <b>Insert underlay</b> dialog.

Raster (  )	Open <b>Insert Raster image</b> dialog box.
Named objects definition (  )	Open content of named objects definition.
Layers (  )	Copy layer to the current drawing. Does not copy if layer with the same name exists in current drawing.
Block (  )	Copy block definition to the current drawing. Does not copy if block with the same name exists in current drawing.
Textstyles (  )	Copy text style to the current drawing. Does not copy if text style with the same name exists in current drawing.
Linetypes (  )	Copy line type to the current drawing. Does not copy if line type with the same name exists in current drawing.
Dimstyles (  )	Copy dimension style to the current drawing. Does not copy if dimstyle with the same name exists in current drawing.
Layout (  )	Copy layout to the current drawing. Correct the layout if list with the same name exists in current drawing.
XRefs (  )	Open <b>Insert External reference</b> dialog box.
Material (  )	The Material is copied to the current drawing. Multiple choice of materials is possible. The new Materials appear in the <b>Materials Browser</b> . If a Material with the same name already exists in the current drawing, it is not copied.

**Following elements contain context menu:**





Element type	Context menu commands
Folder (  )	<p><b>Explore</b> – transition into the folder;</p> <p><b>Set as Home</b> – selected folder becomes a Home (main) folder.</p> <p><b>Add to Favorites</b> – adding a link to the selected folder to the <b>Favorites</b> folder.</p> <p><b>Organize Favorites</b> – opens the <b>Favorites</b> folder in Windows explorer, which allows for a wide range of actions with files.</p>
Drawing file (  )	<p><b>Explore</b> – transition into list of named objects definitions;</p> <p><b>Attach as XRef...</b> – open <b>Insert External reference</b> dialog box;</p> <p><b>Open...</b> – open selected file;</p> <p><b>Insert as Block...</b> – open <b>Insert Block</b> dialog box;</p> <p><b>Create tool set</b> – a tool set is created from all blocks of this file;</p> <p><b>Set as Home</b> – selected file becomes a home (main) folder.</p> <p><b>Add to Favorites</b> – adding a link to the selected file to the <b>Favorites</b> folder.</p>



	<p><b>Organize Favorites</b> – opens the <b>Favorites</b> folder in Windows explorer, which allows for a wide range of actions with files.</p>
<p>Underlay ()</p>	<p><b>Insert underlay...</b>– open <b>Insert Underlay</b> dialog box.</p> <p><b>Add to Favorites</b> – adding a link to the selected file to the <b>Favorites</b> folder.</p> <p><b>Organize Favorites</b> – opens the <b>Favorites</b> folder in Windows explorer, which allows for a wide range of actions with files.</p>
<p>Raster Image ()</p>	<p><b>Attach raster ...</b> – open <b>Insert Raster Image</b> dialog box.</p> <p><b>Add to Favorites</b> – adding a link to the selected file to the <b>Favorites</b> folder.</p> <p><b>Organize Favorites</b> – opens the <b>Favorites</b> folder in Windows explorer, which allows for a wide range of actions with files.</p>
<p>Named objects definition ()</p>	<p><b>Explore</b> – open content of named objects definition.</p> <p><b>Create tool set</b> – a tool set is created from all blocks of this file (only for table of blocks).</p>
<p>Layers ()</p>	<p><b>Add layer(s)</b> – copy layer to the current drawing. Does not copy if layer with the same name exists in current drawing.</p>
<p>Blocks ()</p>	<p><b>Insert Block(s)</b> – open Insert Block dialog box.</p>
<p>Textstyles ()</p>	<p><b>Add Textstyle(s)</b> – copy text style to the current drawing. Does not copy if text style with the same name exists in current drawing.</p>
<p>Linetypes ()</p>	<p><b>Add Linetype(s)</b> – copy line type to the current drawing. Does not copy if line type with the same name exists in current drawing.</p>
<p>Dimstyles ()</p>	<p><b>Add Dimstyle(s)</b> – copy dimension style to the current drawing. Does not copy if dimstyle with the same name exists in current drawing.</p>
<p>Layouts ()</p>	<p><b>Add Layout(s)</b> – copy layout to the current drawing. Correct the layout if list with the same name exists in current drawing.</p>
<p>XRefs ()</p>	<p><b>Attach ...</b> – open <b>Insert External reference</b> dialog box</p>
<p>Material ()</p>	<p><b>Add</b> – the selected materials are copied into the current drawing, the names of which do not repeat the names of already existing materials in the current drawing. The new materials appear in the <b>Materials Browser</b>.</p>

## File Explorer Toolbar



File Explorer dialog box contains toolbar placed under window title.

### Toolbar buttons:





Button	Command
	Select file in a tree with <b>Open</b> dialog box.
	Returns to the most recent location.
	Returns to the next later location.
	Returns to your home (main) folder.
	Transfer to the <b>Favorites</b> folder.

	Returns to one level above the current folder.
	Select display formats for the content that is loaded in the right area ( <b>Large icons, Small icons, List, Details</b> ).

Toolbar contains context menu that is identical to **View > Toolbars**:

Item	Context menu command
 <b>Customize...</b>	Open <b>Customize</b> dialog box.
 <b>nanoCAD Toolbars</b>	Show/hide nanoCAD toolbars.
 <b>Set configuration file...</b>	Calls the <b>Configuration files</b> dialog box.
<b>Toolbars</b>	Submenu of loading and uploading of tool palettes.
<b>Functional</b>	Show/hide functional toolbars.

## Drawing Comparison

-  Ribbon: **Options – Functional Bars >  Compare Files**
-  Menu: **Tools –  Compare Files...**
-  Menu: **View – Toolbars – Functional –  Compare Files...**
-  Toolbar: **Standard – **
-  Command line: **DWGCOMPARE**

File comparison feature allows you to find the differences between the contents of the model space in two drawings: detect objects that have been modified, added, or removed in the compared drawings.

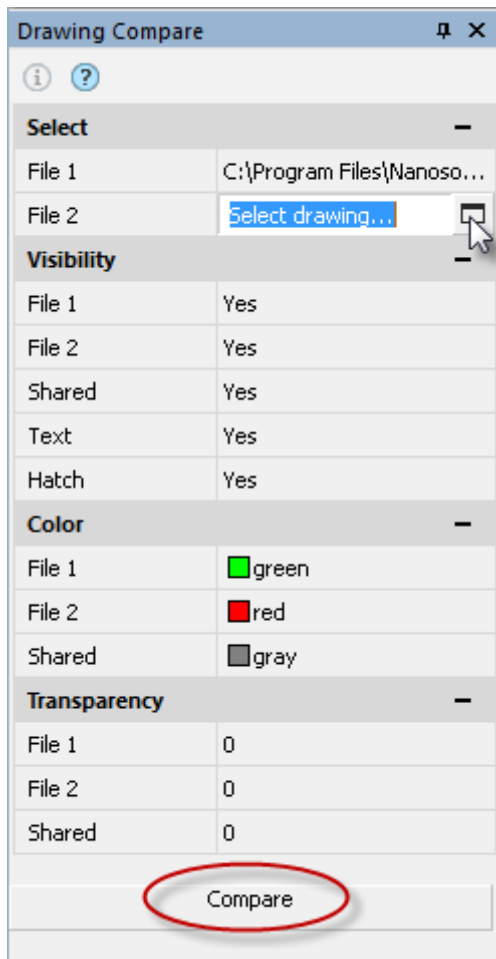

The **Drawing Compare.dwg** toolbar is designed to detect changes in different versions of drawings.

The comparison process determines objects that were changed, added or removed.

There is a number of limitations to using the **Drawing Compare .dwg** function:

- The function works only in the model space.
- Only **.dwg** files are supported.
- The following types of objects are not supported: OLE objects, cameras, geographic data, GIS objects from Map 3D, underlays (not dwg), images, coordination models, and point clouds.
- Changes of properties By Block and By Layer are not detected in nested blocks.

### To compare files:

1. Start the **Compare Files** command to open **Drawing Compare** panel.
2. Click the  button in the **File1** field in the **Select** section. In the dialog that opens, select the first drawing file for comparison.
3. Do the same for the **File2** field.
4. Set the **Visibility**, **Color** and **Transparency** settings for the compared files.
5. Click the **Compare** button.

A new document tab will open with the name **Result of comparing** and the names of the files being compared. Visual differences between drawings will be displayed with the options set in the **Drawing Compare** toolbar.

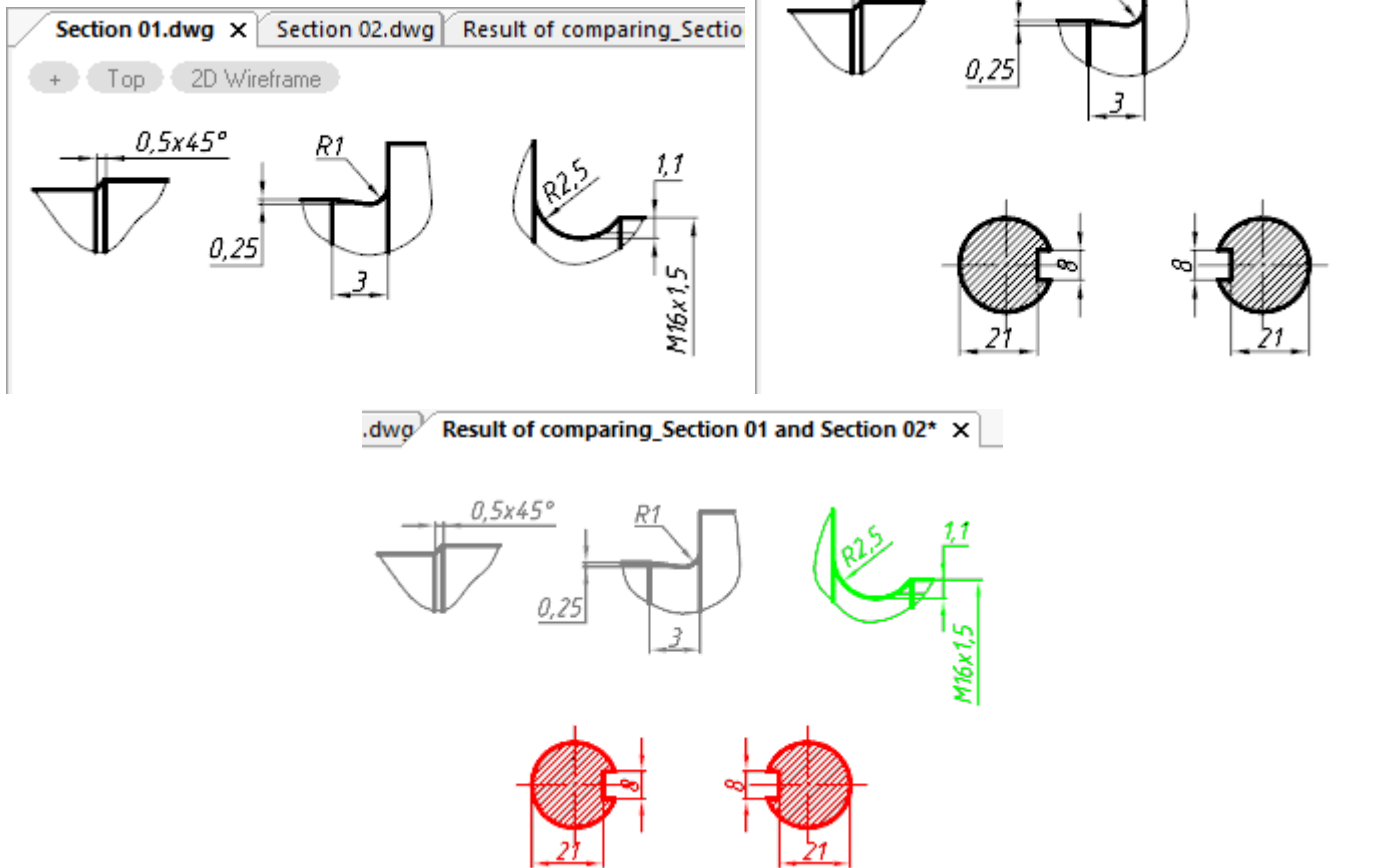

You can control the display parameters of the comparison result both before the procedure and after displaying it on the screen.

### Options:

#### Visibility

- File 1** Controlling the visibility of objects belonging only to file 1.
- File 2** Controlling the visibility of objects belonging only to file 2.
- Shared** Controlling the visibility of objects belonging to both files.
- Text** Showing/hiding the results of comparing text objects.
- Hatch** Showing/hiding hatch comparison results.

#### Color

- File 1** Color for objects belonging only to file 1.
- File 2** Color for objects belonging only to file 2.
- Shared** Color for objects belonging to both files.

#### Transparency

- File 1** Transparency of displaying objects belonging only to file 1.
- File 2** Transparency of displaying objects belonging only to file 2.
- Shared** Transparency of displaying objects belonging to both files.

Click the  icon to open a dialog with information about the compared files:

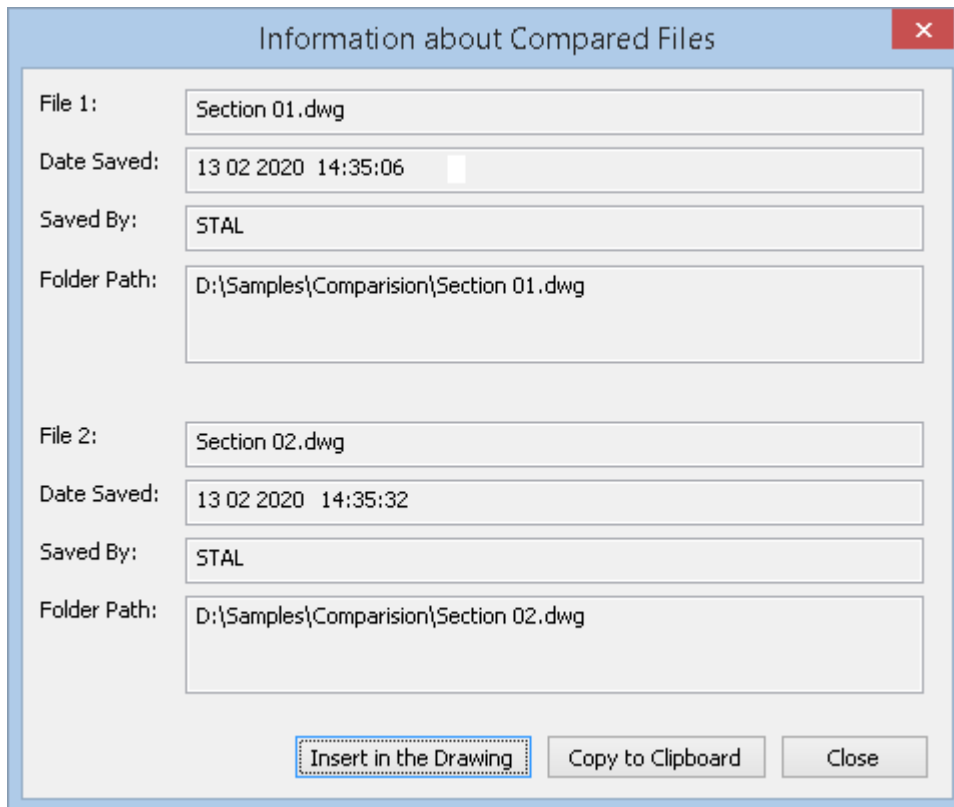

The dialog box, titled "Information about Compared Files", displays details for two files. The first file, "Section 01.dwg", was saved on 13 02 2020 at 14:35:06 by user STAL at the path D:\Samples\Comparision\Section 01.dwg. The second file, "Section 02.dwg", was saved on 13 02 2020 at 14:35:32 by user STAL at the path D:\Samples\Comparision\Section 02.dwg. At the bottom, there are three buttons: "Insert in the Drawing" (highlighted with a dashed border), "Copy to Clipboard", and "Close".

File	Date Saved	Saved By	Folder Path
Section 01.dwg	13 02 2020 14:35:06	STAL	D:\Samples\Comparision\Section 01.dwg
Section 02.dwg	13 02 2020 14:35:32	STAL	D:\Samples\Comparision\Section 02.dwg

When closing a document, the program offers to save the comparison result and opens the standard **Save Document File** dialog.



## TUNING NANOCAD

---

User can change different parameters of nanoCAD.

### *Migration of Settings from Previous Versions*

Settings from installed previous versions of nanoCAD can be copied to new version.

On the first start nanoCAD will display **Migration of settings** dialog with list of all previously installed nanoCAD versions:

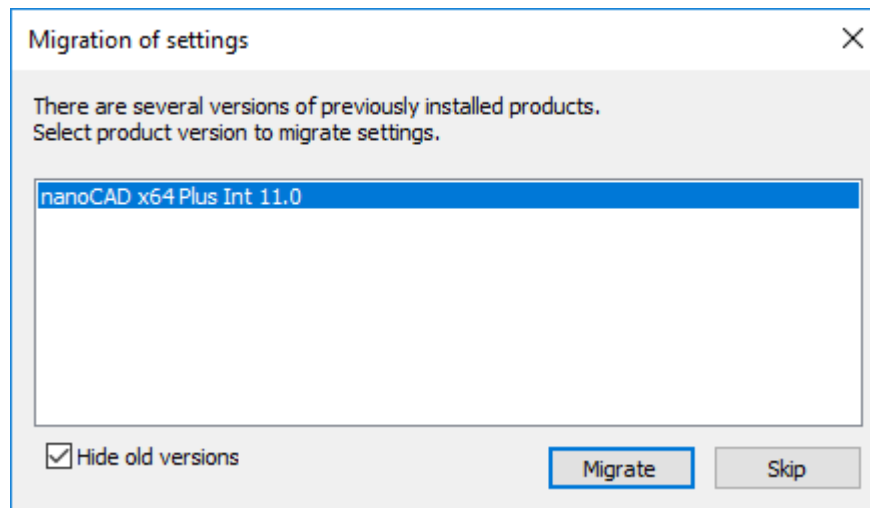

Clear the **Hide old versions** checkbox to show settings from earlier versions of nanoCAD (enabled by default). Select desired version or click **Skip** button to skip migration.

**NOTE:** Only nanoCAD settings from the **Options** dialog will be copied. The interface configurations (location of interface elements and their content) are transferred and copied by [UIIMPORT](#) and [UIEXPORT](#) commands.

To restore default program settings use **Reset All** button in the [Profiles](#) dialog

The user can change various parameters of the nanoCAD working environment.

### *Migrating Settings at Minor Update*

If a minor update of the program was installed over the already installed one, then the first time you start nanoCAD, a window will open asking if you want to save the previous user settings of the program.

nanoCAD x64 Int 22.2

 **Keep custom settings after upgrade**

You can keep custom options, design settings, interface in the renewed version or reset them to the default state.

→ **Keep custom settings:**

- program settings from the Options dialog;
- design settings from the Desing Settings dialog;
- customization settings (ribbon, menus, toolbars, etc.) from the Interface dialog;
- custom profiles including program settings and design settings;
- aliases from nCad.pgp file;
- tools and their location on Tool Palettes bar.

→ **Reset custom settings to the default state:**

- backup copy of all custom settings will be saved in C:\Users\Inz20\AppData\Roaming\Nanosoft\nanoCAD x64 Int 22.2\Config folder in the file with .BAK extension;
- backup copy of Tool Palettes will be saved in C:\Users\Inz20\AppData\Roaming\Nanosoft\nanoCAD x64 Int 22.2\ToolPalette folder.

Selection of **Keep custom settings** saves the created and installed profiles. The profile installed when exiting the program before the upgrade will open in the upgraded version.

Selection of **Reset custom settings to the default state** saves the profiles. The profile set when exiting the program before the update will not open in the updated version, the **Default** profile will be installed instead. The remaining profiles will remain in the [Profiles](#) dialog with all settings.

If you change the **Default** profile, its settings are transferred to the updated version.

Resetting user settings only resets the interface settings of the [Customize inetrface](#) dialog (INTERFACE command). The program settings in the [Options](#) dialog (OPTIONS command) and [Design settings](#) (PARAMS command) remain the same.

Regardless of resetting or saving user settings, the new version updates the functionality and adds new items to all settings dialogs.

## Transferring User Interface Settings

To transfer user interface settings between the program versions or from one computer to another, the following commands are used: UIIMPORT and UIEXPORT.

### Exporting User Interface Settings



Ribbon: **Manage – Customization – Interface** >  **Export UI**



Menu: **Tools – Customize** >  **Exporting the Interface**



Command line: **UIEXPORT**

The **Export UI** command allows you to save interface settings into a special package (ZIP file), which can be used to save and transfer settings.

The following is saved:

- Composition of interface elements (composition of the ribbon, toolbars, etc.) configured in the [Customize user interface](#) dialog;
- Interface settings performed manually:
  - State of displaying elements (displayed or not); Location of interface elements (position of toolbars, functional panels, command line);
  - Visual style of the interface;
  - The way the ribbon is displayed;
  - Size and position of the program window.

After configuring the interface, run the command and in the dialog box specify a place to save the package.

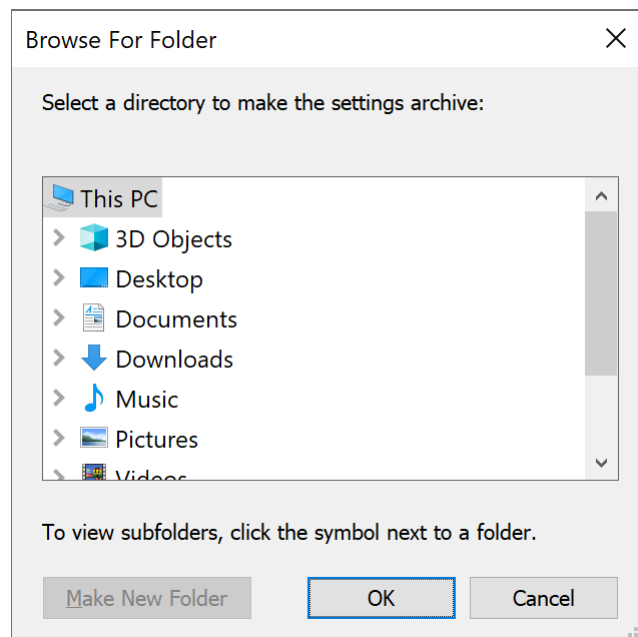

One of the files in the file package is the file `saveduistate.cfg`, containing interface settings performed manually. This file can also be created using the `SAVEUISTATE` command. If necessary, you can replace this file in the package.

## ***Editing the file package composition***

If necessary, you can edit the LSP file describing `UIIMPORT` and `UIEXPORT` commands, and change (delete or add) formats and particular files included in the exported package of settings.

The `UITransfer.lsp` is located in the folder `C:\Program Files\Nanosoft AS\nanoCAD xx.x\Lsp`.

**NOTE:** Before making any changes to `UITransfer.lsp`, make its backup copy to prevent loss of a correctly functioning file.

In order to edit the file, open it in any script editor, for example, in nanoCAD [Script editor](#).

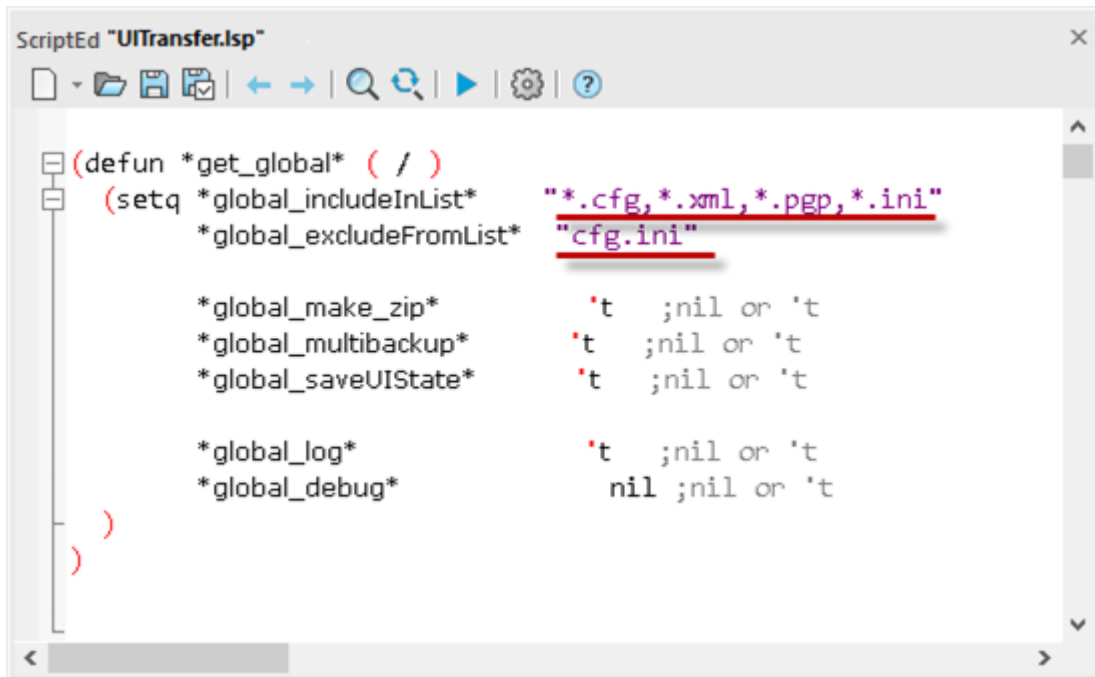

```

(defun *get_global* ( / )
  (setq *global_includeInList* ""*.cfg,*.xml,*.pgp,*.ini"
        *global_excludeFromList* "cfg.ini"

        *global_make_zip*      't ;nil or 't
        *global_multibackup*   't ;nil or 't
        *global_saveUIState*   't ;nil or 't

        *global_log*          't ;nil or 't
        *global_debug*        nil ;nil or 't
  )
)
  
```

The *global\_IncludeInList* line specifies the file formats and files that will be included in the set. By default, these are CFG, XML, PGP, INI formats.

The *global\_excludeFromList* line specifies the file formats and files to be excluded. By default, this is the *Cfg.ini* file. By adding or removing formats and files, you can change the resulting settings package.

Save the modified file.

## Importing User Interface Settings



Ribbon: **Manage – Customization – Interface** >  **Import UI**



Menu: **Tools – Customize** >  **Importing the Inetrface**



Command line: **UIIMPORT**

The **Import UI** command allows you to download a package with user interface settings.

**NOTE:** The ZIP-file should be previously created by the **Export UI** command.

In order to apply the saved user settings to the current program version, it is necessary after starting the command to select the package of settings in the emerging dialog box.

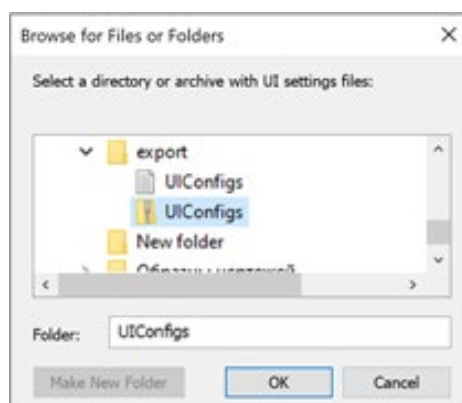

After the import is completed, to apply the settings, the interface will be reset by the [Restore Interface Elements](#) (RESTOREUISTATE) command.

To complete the transfer of settings, restart the program.

## Tuning Program Parameters

 nanoCAD Button:  **Options...**

 Ribbon: **Manage – Customization** –  **Options...**

 Menu: **Tools** –  **Options...**

 Hotkeys: **CTRL+9**

 Command line: **OPTIONS, PREF**

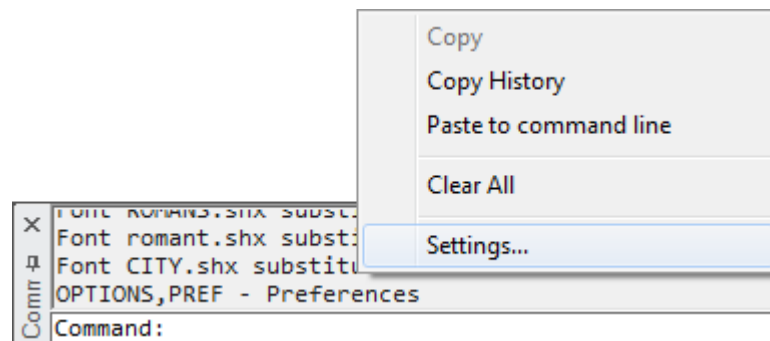

You can launch the command from the context (right-button) menu of the command line:



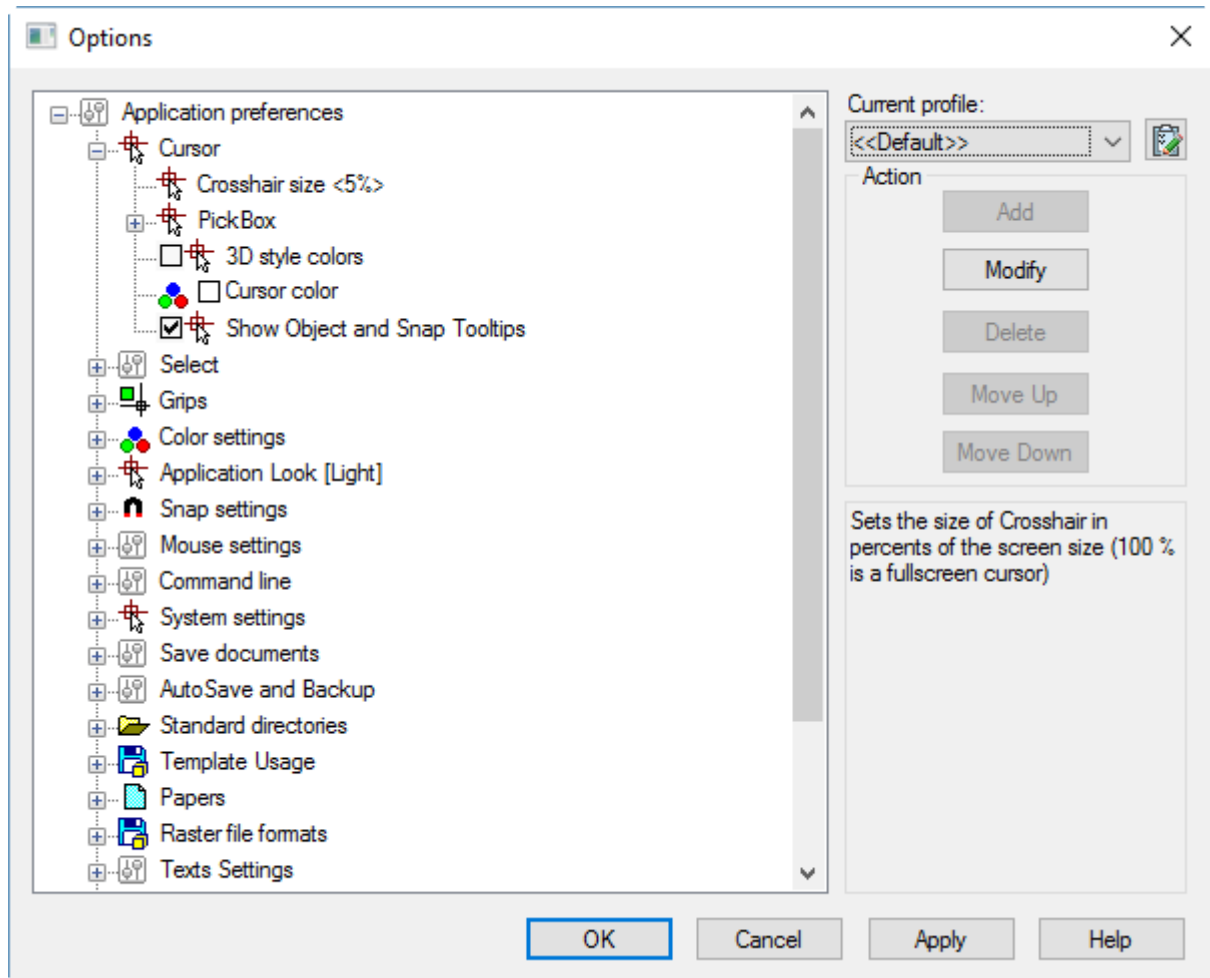

Tuning program parameters is performed in the **Options** dialog box:



There is a tree of options, grouped by sections, in the left part of the dialog box.

To see the parameters of the group, click twice on the name of the section or select the  icon to the left of the section name. If you click the  icon, the section (subsection) will be closed.

The **Add**, **Modify** and **Delete** buttons of the **Action** section become available; this means that the selected parameter from the tree can be edited.

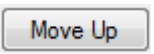
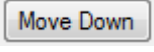
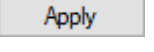
	Adds new option to the selected subfolder.
	Modifies the selected option.
	Deletes the selected option.
	Moves the selected option up.
	Moves the selected option down.
	Applies changes without closing dialog.

The lower right field of the dialog displays brief information about the selected section, subsection or parameter.









**To change a value of a parameter:**

- Select/deselect the checkbox to the left of the parameter
- or
- Click twice on the parameter
- or
- Select the parameter and select the **Modify** button.

## Parameters





### Cursor









 The section of graphic cursor setting.

	<b>Crosshair size&lt;5%&gt;</b>	Sets the size of the crosshair as a percentage of the display size.
	<i>Pickbox</i>	The pickbox size.
	<b>PickBox size &lt;4&gt;</b>	pickbox size in pixels.
<input type="checkbox"/> 	<b>3D style colors</b>	3D color style for the crosshair and pickbox.
	<b>Cursor color</b>	<p>Cursor color. The default is white. When assigning a cursor color in <i>grayscale</i>, the cursor display in the graphic area of the drawing is inversely adjusted to the background color (on light it becomes dark, on dark it becomes light). A Grayscale color has the same RGB components, for example  Red = 127, Green = 127, Blue = 127. White (RGB 255, 255, 255) and black (RGB 0, 0, 0) colors are included in this color mode. For any other combinations of RGB components, the cursor color will be displayed according to the user-specified parameters.</p> <p>If the <b>Use default color</b> option is selected in the <b>Category Name and Color</b> window, the specified cursor color will be ignored () , the cursor color will inversely adjust to the background color, including colored</p>
<input checked="" type="checkbox"/> 	<b>Show Object and Snap Tooltips</b>	Switches object tooltips on/off.

### Select









 Parameters of frames to select objects.

	<b>Color frame</b>	Color frame.
	<b>Color fence</b>	Color fence.
	<b>Transparency &lt;70&gt;</b>	Transparency of frame and fence.
	<b>Object limits for Inspector palette &lt;25000&gt;</b>	Limits the number of objects that can be changed at one time in the <b>Properties</b> functional bar. Value can be changed from 0 to 32767. 0 – switch of the limit edited

		objects, but this can decrease performance in large drawings. The limit doesn't affect to <b>General</b> section in <b>Properties</b> functional bar).
	<i>Window selection method</i>	Defines the method of objects selection in a drawing.
	<b>Click and Click</b>	Specifies two points of selection fence or frame by two clicks.
	<b>Press and drag</b>	Press left mouse button and drag the cursor to stretch selection frame. Then release the mouse button.
	<b>Both – Automatic detection</b>	The method is chosen automatically by the program.
	<b>Lasso selection</b>	Enables/Disables the lasso selection method.
	<b>Keep pre-selection after modification</b>	On/Off keep pre-selection after modify commands: Move, Rotate and Scale. When this mode is enabled, the selection set includes: objects modified or created as a result of the Move, Rotate, Scale, Mirror, or Copy command, as well as selected source objects and objects created as a result of the Array command. Cancel the selection of objects by pressing the <b>ESC</b> key.
	<i>Selection preview</i>	Selections preview settings.
	<b>Selection preview max objects count &lt;100&gt;</b>	Max count of selected objects in preview. The zero value disables preview.

## Object Highlighting

 Objects highlight style.



	<i>Selected objects</i>	How to highlight objects in selection set.
	<i>Line highlight style</i>	How to highlight edges and linear parts of objects.
	<b>Object highlighting the dotted lines</b>	Use dotted lines to highlight lines.
	<b>Color and transparency</b>	Highlight lines using color and transparency.
	<i>Face highlight style</i>	How to highlight faces.
	<b>Object highlighting by pattern</b>	Highlight faces using object texture.
	<b>Color and transparency</b>	Highlight faces using color and transparency.
	<i>Selection preview</i>	How to highlight objects in selection preview.



	<i>Line highlight style</i>	How to highlight edges and linear parts of objects.
	<b>Object highlighting</b>	Highlight lines using object highlighting.
	<b>Color and transparency</b>	Highlight lines using color and transparency.
	<i>Face highlight style</i>	How to highlight faces.
	<b>Object highlighting by pattern</b>	Highlight faces using object texture.
	<b>Color and transparency</b>	Highlight faces using color and transparency.









## Fade Control

 Objects fading level.

	<b>Xref display</b>	Controls the dimming for all Xref-objects in a drawing. (XDWGFADE system variable).
	<b>In-place edit and annotative representations</b>	Specifies the fading intensity value for drawing objects during in-place reference or block editing (XFADECTL system variable).
	<b>Locked layers</b>	Controls the amount of fading for objects on locked layers. (LAYLOCKFADECTL system variable).

## Grips





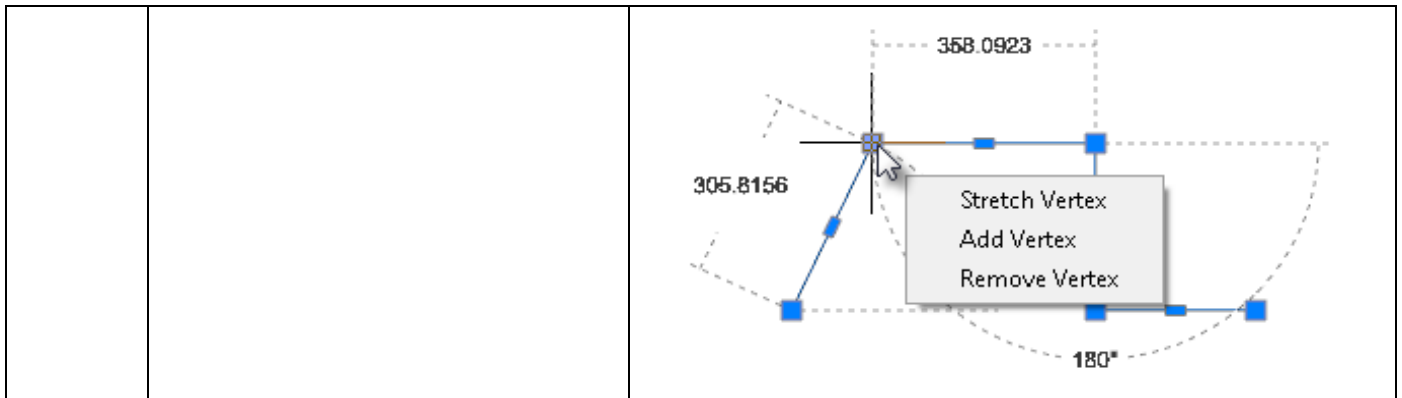







 Parameters of the grips of the selected objects.

	<b>Grip size &lt;5&gt;</b>	Grip size in pixels.
	<b>Grip max objects count &lt;100&gt;</b>	The maximum number of selected objects that can still display grips. Grips will not be displayed if the number of selected objects is greater than the specified value.
	<b>Grips color</b>	Grips color.
	<b>Hovered grips color</b>	Grips color under cursor.
	<b>Selected grips color</b>	Selected grips color.
	<b>Dynamic block grips color</b>	Color of grips of dynamic blocks.
	<i>Multifunctional grips</i>	Controls the way to access object editing commands using multifunction grips (GRIPMULTIFUNCTIONAL variable).
<input checked="" type="checkbox"/> 	<b>By pressing Ctrl</b>	The parameters of multifunction grips become available when the <b>CTRL</b> key is pressed repeatedly.
<input checked="" type="checkbox"/> 	<b>By menu</b>	A pop-up menu with options for multifunction grips appears, when cursor is placed at an object grip.



## Color Settings

 Colors of the program components.

 ■	<b>Model space Color</b>	The color of background in model space.
 □	<b>Paper space Color</b>	The color of layout in paper space.
 ■	<b>Layout Background Color</b>	The color of background in paper space.
 ■	<b>Grid Color</b>	The color of Grid points.
 ■	<b>Print Area Color</b>	The frame color that indicates a print area.
 ■	<b>Print Margins Color</b>	The frame color that indicates the paper format edges.
 □	<b>Block Editor Background</b>	Block Editor background color.
 ■	<b>Orbit Center</b>	The color of Center mark for <b>Virtual Trackball</b> command.
 ■	<b>Pan Center</b>	The color of Center mark for <b>Pan</b> command in PERSPECTIVE=1 mode.
 ■	<i>Dimensional constraints</i>	The color of dimensional constraints.
 ■	<b>Dimension lines</b>	Set color for dimension lines (DYNCONSTRAINTSCOLOR system variable)
 ■	<b>Dimension texts</b>	Set color for dimension texts (DYNCONSTRAINTSTXTCOLOR system variable)

## Application Look

 Select one of predefined visual styles:











- **Windows default**
- **Aqua**
- **Blue Laguna**
- **Deep Ice**
- **Graphite**

- Iceberg
- Light
- Obsidian Black
- Platinum
- Silver
- Steel

**NOTE:** You can use **Apply** button for fast preview of the selected visual.

## Snap Settings





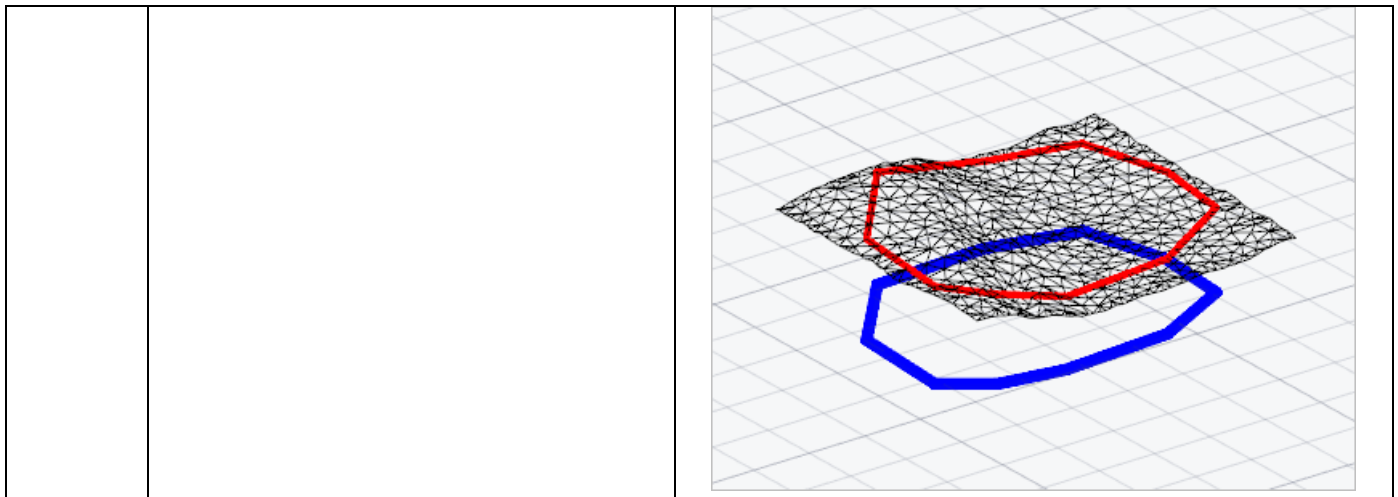







 Defines the Snap settings.

	<b>Hold Aperture Size &lt;10&gt;</b>	The size of a cursor frame in snap mode.
<input type="checkbox"/> 	<b>Show Aperture Box</b>	Switches the aperture box on/off in the snap mode.
	<b>Snap Marker size &lt;5&gt;</b>	Snap marker size.
<input checked="" type="checkbox"/> 	<b>Show Tooltips</b>	Turns on the display of a snap name.
	<b>Vector Marker Color</b>	The color of the snap marker when snapping to a vector object.
	<b>Otrack marker color</b>	Sets color of object snap tracking marker in snap to vector object.
	<b>Rays color</b>	Sets color of rays in snap to vector object.
	<i>Snap for Objects</i>	Sets snap for different objects.
<input checked="" type="checkbox"/> 	<b>Snap for Dimensions</b>	Indicates whether the dimensions considered in the calculation of the intersection points.
<input checked="" type="checkbox"/> 	<b>Snap for Layouts</b>	Indicates whether the layout borders considered in the calculation of the intersection points.
<input type="checkbox"/> 	<b>Replace Z value with Current Elevation</b>	<p>Controls the value of Z coordinate in an object snap.</p> <p>When the option is disabled, the value of Z coordinate of the specified point is used.</p> <p>When the option is enabled, the value of Z coordinate is replaced by the value of its projection to XY plane of the current UCS or, if non-zero value is set for the ELEVATION variable, on the plane parallel to XY plane on the preset level. The option is synchronized with the OSNAPZ variable.</p> <p>Below there are two 3D polylines created with a snap to mesh vertices. Red – in a common snap mode, blue – when the option of Z-coordinate replacement is enabled:</p>













## Dynamic input

 Manages mouse input, dimension input, dynamic tooltips, and tooltip appearance.

<input checked="" type="checkbox"/> 	<b>Pointer input on</b>	Enables mouse input.
<input checked="" type="checkbox"/> 	<b>Dimensional input on</b>	Enables dimensions input.
	<i>Pointer input options</i>	Set tooltips parameters for mouse input.
	<i>Polar or Cartesian input format</i>	Manages the display of tooltips in polar or Cartesian coordinate formats.
<input checked="" type="radio"/> 	<b>Use polar format</b>	Displays tooltips in polar coordinate format.
<input type="radio"/> 	<b>Use cartesian format</b>	Displays tooltips in Cartesian format.
	<i>Relative or Absolute input format</i>	Manages the display of tooltips in relative or absolute coordinate formats.
<input checked="" type="radio"/> 	<b>Use relative format</b>	Displays tooltips in relative coordinate format.
<input type="radio"/> 	<b>Use absolute format</b>	Displays tooltips in absolute coordinate format.
<input checked="" type="checkbox"/> 	<b>Show prompt</b>	Enables/Disables the display of dynamic input prompts.
 <input type="checkbox"/>	<b>Tooltip color</b>	Sets the tooltip color.
	<b>Tooltip transparency</b> <0%>	Sets the tooltips transparency.



## Mouse Settings







### 3D Orbit and Free Orbit Settings

<input checked="" type="checkbox"/> 	<b>Horizon lock</b>	If the setting is enabled, then when the model is rotated, the projection of the Z axis remains vertical in the screen plane. When disabled, model rotation is not limited. Controlled by the VIEWHORIZON system variable.
	<b>3D Orbit mouse sensitivity</b> <300>%	Rotation speed adjustment. The minimum rotation speed is 25%, the maximum is 400% of the nominal value. The default is 300%.
<input checked="" type="checkbox"/> 	<b>Rotate the model with the mouse wheel</b>	If the setting is enabled, then pressing the mouse wheel (or the combination of SHIFT + mouse wheel) will be used to launch the 3D Orbit command in transparent mode.  If the setting is disabled, then pressing the mouse wheel (including in combination with SHIFT) will not launch the 3D Orbit command. Only panning will be performed.
	<i>Rotate model:</i>	Section for specifying the model rotation method.
<input checked="" type="checkbox"/> 	<b>SHIFT+mouse wheel</b>	Mouse wheel click to pan. Enables/disables rotation of 3D orbit when using <b>SHIFT</b> +mouse wheel (starts the <b>3D Orbit</b> command in transparent mode).
<input type="radio"/> 	<b>Mouse wheel</b>	By pressing the mouse wheel, the model is rotated (the <b>3D Orbit</b> command is launched in transparent mode). While the combination of <b>SHIFT</b> + mouse wheel performs panning.
	<i>Orbit center</i>	Locates rotation center of 3D Orbit and Free Orbit.
<input checked="" type="radio"/> 	<b>Visible objects</b>	Places rotation center to the center of objects you're viewing.
<input type="radio"/> 	<b>Visible parts of objects</b>	Places rotation center to the center of objects parts you're viewing.
	<b>Mouse Wheel scale factor</b> <1.5>	Scale factor used to scale with the Mouse Wheel. If scale factor is more than 1 - forward scrolling increase the scale, if less than 1 - decrease. If 1 - scaling using mouse wheel is disabled.

### Right Button Usage

 The section redefines functions of the right button.

	<i>Default Mode:</i>	This section defines the behavior of the right mouse button in normal mode, when there are no objects selected and no running commands.
<input type="radio"/> 	<b>Repeat last command</b>	Disables the standard right-click context

		menu. Simulates pressing the <b>ENTER</b> key, which causes the last command to run again.
	<b>Shows Popup Menu</b>	Displays the standard context menu.
	<i>Edit Mode:</i>	This section defines the behavior of the right mouse button in edit mode when objects are selected but there are no running commands.
<input type="radio"/>	<b>Repeat last command</b>	Disables the right-click context menu. Simulates pressing the <b>ENTER</b> key, which causes the last command to run again.
	<b>Shows Popup menu</b>	Displays the context menu for editing selected objects.
	<i>Command mode:</i>	This section defines the behavior of the right mouse button when it is pressed during a running command.
<input type="radio"/>	<b>Sends "ENTER"</b>	Disables the right-click context menu. Simulates pressing the <b>ENTER</b> key.
<input type="radio"/>	<b>Shows Popup menu</b>	Displays the context menu of the running command.
	<b>Shows Popup menu when command options present</b>	Calls the context menu of a command only if there are available options in the command line. If there are no options in the command line, pressing the right mouse button corresponds to pressing <b>ENTER</b> .
<input checked="" type="checkbox"/>	<i>Shows Popup menu after delay</i>	Enables the mode which considers the duration of right button holding: short click – repetition of command or simulating pressing the <b>ENTER</b> key, according to the mode, long hold – opens the context menu.
	<b>Delay &lt;250&gt; ms</b>	Specifies in milliseconds, the duration of right button holding to open the context menu. By default, the value is 250 ms.
<input checked="" type="checkbox"/>	<b>Always show Popup menu when objects selected</b>	If enabled, then if there is one or more objects in the selection, pressing the right mouse button always brings up the context menu, regardless of the duration of the press.

	<b>Scroll screen pages &lt;3&gt;</b>	A document Scrollbar movement range.
---	--------------------------------------	--------------------------------------

## Floating windows















 Section to configure interface of the [floating document window](#).



<input checked="" type="checkbox"/>	<b>Ribbon and menu bar</b>	Whether a document floating window should contain the ribbon and menu bar.
-------------------------------------	----------------------------	--

<input checked="" type="checkbox"/> 	<b>Status bar</b>	Whether a document floating window should contain the status bar.
---	-------------------	---

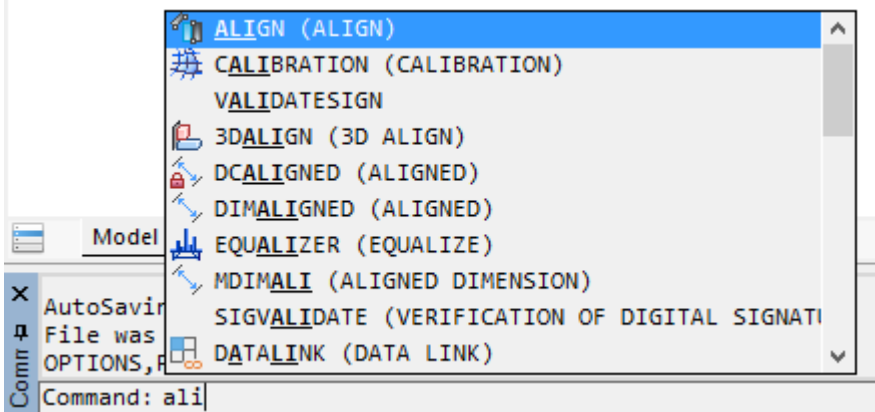
## Command Line









 The section sets the parameters of the command line.

<input checked="" type="checkbox"/> 	<b>Use Autocomplete</b>	Switches on/off the auto complete mode, when after entering one or several first letters of the command, the command is auto completed in the command line.
	<i>Autoselect mode</i>	Advanced options of autocomplete.
<input type="radio"/> 	<b>Don't select</b>	Manual selection.
<input checked="" type="radio"/> 	<b>Select on prefix</b>	When fuzzy complete disable: first item will be selected only if it has common prefix with command line. When fuzzy complete enable: item will be selected if it has common characters with command line. For example, <b>zll</b> selects <b>ZoomAll</b> command.
<input type="radio"/> 	<b>Always select</b>	First item will be selected always.
	<i>Completion content</i>	Autocompletion list content.
<input checked="" type="checkbox"/> 	<b>Complete system variables</b>	Shows system variables in autocompletion list.
<input checked="" type="checkbox"/> 	<b>Complete blocks</b>	Shows block names in autocompletion list.
<input checked="" type="checkbox"/> 	<b>Complete tools</b>	Shows commands from Tool Palette in autocompletion list.
	<i>Additional options</i>	Additional options of autocomplete.
<input checked="" type="checkbox"/> 	<b>Autocomplete during delay</b>	Selection of the most probable command before autocomplete list is.
	<b>Completion list delay: &lt;0.3&gt; s</b>	Amount of time that elapses before completion list is shown. 
<input checked="" type="checkbox"/> 	<b>Fuzzy complete</b>	Automatic correction of errors while typing.
 <input type="checkbox"/>	<b>Command line</b>	Sets the background color of the command line.











	<b>background color</b>	
	<b>Command line text color</b>	Sets the text color of the command line.
	<b>Use alternate font</b>	Switches on/off the using of alternative font in the command line.
	<b>Font Height &lt;12&gt;</b>	Specifies font height in the command line.

## System Settings

 [Video subsystem and graphic displaying settings.](#)















	<b>Vectorizer Type</b>	Specifies graphic hardware acceleration library to use by program. This setting will be applied after restart of the nanoCAD.
<input checked="" type="radio"/> 	<b>OpenGL</b>	Use OpenGL
<input type="radio"/> 	<b>DirectX</b>	Use DirectX By default, when you select DirectX, DirectX 11 is activated. If it is not supported (for example, when working via RDP), then DirectX 9 is activated. You can manually change the DirectX version using the <b>DirectX enhanced compatibility mode</b> option or the NCGS_TOGGLE_DIRECTX command.
<input type="checkbox"/> 	<b>Use anti-aliasing</b>	Enables/Disables the jagged smoothing effect when displaying drawing graphics (antialiasing). Smoother line displaying. Setting will be applied for new opened or created document. This effect does not work when <i>enhanced compatibility mode</i> is enabled.
	<b>Rendering optimization</b>	Rendering optimization settings.
<input type="checkbox"/> 	<b>Optimize rendering objects with linewidth</b>	Disables linewidth in navigation mode – Zoom, Pan, etc.
<input type="checkbox"/> 	<b>Optimize small details rendering</b>	Disables points and other graphic with the same size in navigation mode – Zoom, Pan, etc.
	<b>Simplify text less than &lt;2&gt; pixels</b>	All text smaller than specified value will be shown in a drawing as empty bounding boxes. Regeneration is required.
	<b>Min mipmap level size &lt;512&gt; pixels</b>	Specifies a minimum level of detail to speed up work with large raster images. Affects on raster mipmap pyramid generation. Defines smallest raster mipmap level in pixels.











	<b>OpenGL settings</b>	OpenGL settings.
	<i>Screen caching</i>	Settings for the <a href="#">automatic</a> and <a href="#">manual</a> setup of OpenGL graphics hardware accelerator. It is recommended to close all opened documents before switching these settings. All changes will be applied only to a newly created and opened documents.
<input type="radio"/> 	<b>Generic</b>	Software screen caching.
<input checked="" type="radio"/> 	<b>Accelerated</b>	Hardware accelerated screen caching.
<input type="checkbox"/> 	<b>Improved compatibility mode</b>	Uses the <a href="#">improved compatibility mode</a> for graphics displaying (can slow down the process of screen redrawing). This mode is a software emulation of OpenGL by basic Windows tools and allows you to refuse to interact with the hardware of the PC graphics system (it can significantly slow down the process of redrawing the image on the screen). In this mode, a number of graphic display functions do not work, incl. smoothing lines on the screen (antialiasing).
	<b>DirectX settings</b>	DirectX settings.
	<b>Sets threshold texture size for texture cache &lt;0.5&gt;</b>	Uses video-memory to speed up displaying of raster images. Images with any bitmap dimension (horizontal or vertical) multiplied with this threshold should be less then <i>maximum gradient size</i> – special value, calculated for current PC video-memory. Threshold should be from 0.1 to 0.5.
<input type="checkbox"/> 	<b>DirectX version used for render</b>	DirectX version used for render. If the box is checked, then DirectX 9 is used. When the box is not checked, the default version of DirectX is used. In most cases, it is DirectX 11, but if it is not supported by the system, then it is DirectX 9. You can also switch DirectX version by the NCGS_TOGGLE_DIRECTX command.
	<b>Print preview mode settings</b>	Section is used to control platform components, used for creation of preview if printing is in metafile format (WMF) or raster image (BMP).
<input checked="" type="radio"/> 	<b>Metafile (WMF)</b>	Used to generate a picture in the image preview window in metafile format (WMF).
<input type="radio"/> 	<b>Bitmap (BMP)</b>	Used to generate a picture in the preview window of a raster image in BMP format.

## Save Documents





 The section sets auto saving and backup parameters.

	<b>Save in a format</b>	List of acceptable formats used to save a file using the <b>Save, Save as</b> commands. the format selected in this list becomes the default format for saving documents specified in the <b>Apply selected format</b> subsection.
	<b>Apply selected format</b>	The subsection to set a type of documents to which the file format selected in the <b>Save in a format</b> section is applied.
<input checked="" type="radio"/> 	<b>None</b>	Saving <i>new</i> documents with <b>Save, Save as</b> commands in the latest format selected in the <b>Save document</b> dialog. Saving <i>open</i> documents with the <b>Save</b> command in their current format, with the <b>Save as</b> command in the latest file format selected in the <b>Save document</b> dialog.
<input type="radio"/> 	<b>For new documents</b>	Saving <i>New</i> documents with the <b>Save</b> command in the file format selected in the <b>Save in a format</b> section. Saving <i>open</i> documents with the <b>Save</b> and <b>Save as</b> commands in their current format.
<input type="radio"/> 	<b>For all documents</b>	Saving both <i>new</i> and <i>open</i> documents with the <b>Save, Save as</b> commands in the format file selected in the <b>Save in a format</b> section.
	<b>Incremental saving mode</b>	Settings of incremental saving – saving, when not a whole file is copied, but only its changed parts.
<input type="radio"/> 	<b>Off</b>	A mode in which incremental saving will not be applied. A full save and full autosave will be performed.
<input checked="" type="radio"/> 	<b>Autosave</b>	A mode in which a full save and incremental autosave will be performed.
<input type="radio"/> 	<b>Save and autosave</b>	A mode in which an incremental save and incremental autosave will be performed
	<b>AutoSave and Backup</b>	Setting autosave and backup parameters.
	<b>Autosaving every &lt;5&gt; min</b>	Saving interval for the current document. Zero value switches off auto saving.
	<b>Autosave folder &lt; &gt;</b>	Folder for auto saved files. Default folder is <i>TEMP</i> .
<input checked="" type="checkbox"/> 	<b>Create backup copy</b>	Switches backup copy mode on/off.
<input checked="" type="checkbox"/> 	<b>Backup original</b>	Switches original backup copy mode on/off.
	<b>Backup folder &lt; &gt;</b>	Folder to save backup files. By default, backup files are saved in the same folder as the original file.

	<b>File history</b>	Settings for saving file history. A mode of saving history is based on the file autosave mechanism. It can be needed if it is necessary to return to previous states of a document file, for example, if it was not save by mistake.
<input checked="" type="checkbox"/> 	<b>Save file history</b>	Whether maintain the autosave history or not.
	<b>Number of stored file versions &lt;5&gt;</b>	Maximum number of autosaved file versions.
	<b>File versions are stored for &lt;15&gt; days</b>	Period of storing autosaved file versions in the storage (in days).
	<b>File history folder &lt; &gt;</b>	Folder for storing autosaved copies.
	<b>Control of simultaneous opening of files</b>	Control mode for simultaneous opening of files.
<input checked="" type="checkbox"/> 	<b>Control when opening a file</b>	Enables/Disables control mode when opening a file.
	<b>User name &lt; &gt;</b>	Visible username.

## Undo Command Settings



 The section sets auto saving and backup parameters.

<input checked="" type="checkbox"/> 	<b>Generate preview</b>	Displays a preview of the result for each step of the <b>Undo</b> command.
<input checked="" type="checkbox"/> 	<b>Clear after save</b>	Clears the list of all <b>Undo</b> actions after saving a document.
<input checked="" type="checkbox"/> 	<b>Track 2D navigation</b>	Filling the <b>Undo</b> command list with 2D navigation commands: Pan, Zoom, etc.
<input checked="" type="checkbox"/> 	<b>Track 3D navigation</b>	Filling the <b>Undo</b> command list with 3D navigation commands: Orbit commands (including <b>SHIFT</b> + mouse middle button), <b>3D Walk</b> , <b>3D Fly</b> , Locator using.
<input checked="" type="checkbox"/> 	<b>Group 2D and 3D navigation</b>	Groups undo for 2D and 3D navigation commands in single step.

## Import/Export and Print Settings

 The section sets settings for import, export and print commands.

<input type="checkbox"/> 	<b>Plot temporary hidden objects</b>	<p>Manages the printing of objects temporarily hidden using the <b>HIDEOBJECTS</b> or <b>ISOLATEOBJECTS</b> commands.</p> <p>When the option is enabled, hidden objects in temporary isolation mode (system variable <b>OBJECTISOLATIONMODE</b> = 0) are printed; when disabled, they are not</p>
--	--------------------------------------	---

		<p>printed.</p> <p>By default, the option is disabled; temporarily hidden objects are not printed.</p>
	<b>Print transformed TTF texts: [as text]</b>	<p>Controls the way of processing “transformed” TTF texts output to different print devices, including creating PDF and similar output formats. The “Transformed” text – text that created with any of the following options applied: oblique angle, compression, stretch, rotation on any angle (excluding 0, 90, 180 and 270 degrees).</p>
	<b>as text</b>	<p>Text will be printed as text object with the same or similar font and attributes. This will keep the text string and makes it searchable, but may cause some visual differences from original representation.</p>
	<b>as graphics</b>	<p>Text will be converted to graphic primitives. The content of text string won't be preserved. In some cases this could be helpful to avoid visual inconsistencies towards the original text representation.</p>

## Standard Directories

 Section for specifying paths to both default folders for storing system files and user folders.

The section sets folders where miscellaneous system files are stored – fonts, line types, hatch patterns, multiline styles, plot styles and configuration files, templates, etc.

nanoCAD searches files in Common files location folders, then in subfolder downwards. First found file will be used and search will be stopped.

In the **Common files location** subsection, the path to the **Samples** folder is indicated, in which sample files are posted that demonstrate individual nanoCAD capabilities.

**NOTE** Path to the **Samples** folder is not displayed in the **Common files location** subsection.

When the program searches for files, folders are viewed in the order they are listed in the subsections of the **Standard directories** section. The contents of the **Common files location** subsection are viewed first, then the contents of the next subsections in the order they are listed (from top to bottom). Folders in subsections are also viewed starting from the top one in the list and ending with the bottom one. At that, if the same file is located in different folders, the search stops as soon as the first copy of the file is found.

You can change search order using **Up** and **Down** buttons. **Add**, **Modify**, **Delete** buttons permits to add, modify or delete folders including default ones. Note that **PlotConfigs** and **PlotSyles** sections can only be modified, not deleted or added new paths.



To restore default folder search paths, you can use the **UnSelect All** button in the **Profiles** dialog (**Manage** menu - **Options...** >  **Profiles** button).





**ATTENTION!** All user settings will be lost when using the **UnSelect All** button!

Dialogs for opening/saving files in nanoCAD are dynamically adjusted to display standard (default) and custom folders. Depending on where in the program the open/save file dialogs are

opened (in other words, what types of file formats the dialogs work with), the corresponding folders are displayed in the **nanoCAD** list of the transition area, the paths to which are specified in the **Standard directories** section.





For example, with the same file search path settings, the lists of nanoCAD folders in the transition area of dialogs when opening drawing files (\*.dwg) or loading linetype files (\*.lin) will be different.





	<b>Common files location</b>	All files placed in this folder will be used primarily for all types files in Standard folders. Search in this subsection is carried out first.
	<b>SHX files location</b>	Path to folders with text fonts, linetypes, hatches, multiline styles. Default value: <C:\ProgramData\Nanosoft AS\nanoCAD Int 24.0\shx>
	<b>Templates files location</b>	Path to folders with nanoCAD template files. Default value: <C:\Users\%User name%\AppData\Roaming\Nanosoft AS\nanoCAD Int 24.0\Templates>
	<b>PlotConfigs files location</b>	Path to folders with Plot Configuration files. Default value: <C:\Users\%User name%\AppData\Roaming\Nanosoft AS\nanoCAD Int 24.0\PlotConfigs>
	<b>PlotStyles files location</b>	Path to folders with Plot Styles files. Default value: <C:\Users\%User name%\AppData\Roaming\Nanosoft AS\nanoCAD Int 24.0\PlotStyles>
	<b>Pat files location</b>	Path to folders with PAT files. Default value: <C:\ProgramData\Nanosoft AS\nanoCAD Int 24.0\shx>
	<b>Tool Palette files location</b>	Path to folders to search for Tool Palette files. Default value: <C:\Users\User_name\AppData\Roaming\Nanosoft AS\nanoCAD 10.3\ ToolPalette>
	<b>PDF import images location</b>	Path to folders to extract and save used image files while importing PDF files: Default value: <C:\Users\User name\AppData\Roaming\Nanosoft AS\nanoCAD 10.3\PDF Import Images>
	<b>OCR template files location</b>	Path to folders to extract and save used OCR template files. Default value: <C:\Users\User_name\AppData\Roaming\Nanosoft\nanoCAD 24.00\OCR>
	<b>Script files location</b>	Paths to folders in which the program should search for script files. Default value: <C:\Users\User_name\AppData\Roaming\Nanosoft\nanoCAD 24.00\Scripts>

	<b>Color books files location</b>	Paths to folders in which the program should search for color books files.
	<b>GeoFiles location</b>	Source files for import. Default value: <C:\Users\ User_name\AppData\Roaming\Nanosoft\nanoCAD 24.00\GeoFiles>
	<b>GeoUnderlays location</b>	Ready-made underlays for insertion into drawings. Default value: <C:\Users\ User_name\AppData\Roaming\Nanosoft\nanoCAD 24.00GeoUnderlays>
	<b>Predefined materials location</b>	Ready-made coverings for insertion into drawings. Default value: <C:\Users\User_name\AppData\Roaming\Nanosoft\nanoCAD 24.00\CoveringsLibrary>
	<b>Classifier location</b>	Path to folders in which the program should search for classifier files. Default value: <C:\Users\User_name\AppData\Roaming\Nanosoft AS\nanoCAD 10.3\classifier>

## Template Usage

 Section to specify templates for new documents and for import and export of documents.

	<b><i>For new documents</i></b>	Actions on the <b>File &gt; New</b> command.
<input type="radio"/>	<b>None</b>	No action taken.
<input checked="" type="radio"/>	<b>Use default</b>	Opens the file specified in the <b>Default Template File Name</b> .
<input type="radio"/>	<b>Ask for file</b>	Opens the <b>File &gt; Open</b> dialog box.
<input type="radio"/>	<b>Choose from list</b>	Opens the <b>Choose Template</b> dialog box.
	<b>Default Template File Name &lt;Default.dwt&gt;</b>	Shows and allows changing of the <b>Default Template File Name</b> .
	<b>Templates Names List</b>	List for <b>Choose Templates</b> .
	<b><i>For imported documents</i></b>	Actions for imported documents.
<input type="radio"/>	<b>None</b>	No action taken.
<input checked="" type="radio"/>	<b>Use default</b>	Opens the file specified in the <b>Default Template File Name</b> .
<input type="radio"/>	<b>Ask for file</b>	Opens the File > Open dialog box.
<input type="radio"/>	<b>Choose from list</b>	Opens the <b>Choose Template</b> dialog box.
	<b>Default Template File Name &lt;Default.dwt&gt;</b>	Shows and allows changing of the Default Template File Name.

	<b>Templates Names List</b>	List for Choose Templates.
	<i>For Export to File</i>	Actions for exported documents.
<input type="radio"/> X	<b>None</b>	No action taken.
<input checked="" type="radio"/>	<b>Use default</b>	Opens the file specified in the <b>Default Template File Name</b> .
<input type="radio"/> ?	<b>Ask for file</b>	<b>Opens the File</b> > Open dialog box.
<input type="radio"/> ?	<b>Choose from list</b>	<b>Opens the Choose Template</b> dialog box.
	<b>Default Template File Name</b> <Default.dwt>	Shows and allows changing of the <b>Default Template File Name</b> .
	<b>Templates Names List</b>	List for the Choose Templates.

## Standards Audit Usage

 Section for managing the settings for using the standard.

<input type="radio"/> X	<b>No</b>	The ban on connecting the standard file to the opened drawings. The option is selected by default.
<input checked="" type="radio"/>	<b>Use for all documents</b>	Permission to use the standard file for all opened documents.
	<b>Standards Audit File Name</b> <>	Specifies a DWS standard file (*.dws). In the <b>Configure Standards</b> dialog box ( <b>STANDARDS</b> command), the assigned file will appear first in the list.

## Papers

 Contains standard paper formats. Allows the modification of an existing format or addition of a new one.

## Raster File Formats



 Raster file formats which can be inserted with **Image from File** command (**Insert** menu).

Available formats:

- **TIF,**
- **TIFF,**
- **BMP (Windows Bitmap),**
- **JPG,**
- **JPEG,**
- **PNG (Portable Network Graphics),**
- **PCX (ZSoft)**
- **GIF**











## Text Settings

 Section to specify a file with font for replacing.

	<b>Alternative font name</b> <txt.shx>	Name of font file to replace a missing font in an opened document.
<input checked="" type="checkbox"/> 	<b>Rotate text in edit mode</b>	Specifies rotation mode for text object editing. If checkbox is ON, then only text object is rotated. Otherwise, the entire drawing rotates.





## API

 Options for [nanoCAD applications developers](#).

<input checked="" type="checkbox"/> 	<b>Reset Ignored exceptions</b>	Reset ignored exceptions. The list of exceptions will be reset after restarting the program.
<input checked="" type="checkbox"/> 	<b>Write API Log</b>	Enables/Disables writing API protocols.
	<b>API Log File Name</b> < >	Specifying the folder and file name of the API protocol.
	<i>When not implemented API is called:</i>	Specifying an action when calling not implemented API.
<input type="radio"/> 	<b>Do nothing</b>	
<input checked="" type="radio"/> 	<b>Show message box</b>	
<input type="radio"/> 	<b>Throw exception</b>	
<input type="radio"/> 	<b>OutputDebugString</b>	
	<b>Developer support email</b> < >	Specifying the developers' email address.
	<b>Temporary files folder</b> < >	Folder for storing temporary files. The default folder is c:\Users\User_name\AppData\Local\Temp

## Feedback







 Section for setting up feedback with developers and support service.

	<i>Sending depersonalized statistics</i>	Setting the mode for sending a log of statistical data on the use of nanoCAD.
<input type="radio"/> 	<b>Not to send</b>	Prohibition to send the log of statistical data.
<input checked="" type="radio"/> 	<b>Resolve sending</b>	Permission to send statistics log.
<input type="radio"/> 	<b>Resolve and report</b>	Permission to send statistical data log and advance information before sending.





## ETransmit

 Create package with all necessary files – external links, raster images, fonts.

	<b>Include unloaded External references</b>	Includes unloaded external references in the file package (XRefs).
	<b>Include fonts</b>	Includes TTF and SHX fonts to the packet used in a document.
	<i>Path options</i>	Settings for packet structure.
	<b>Use Organized Structure</b>	<p>Duplicates the folder structure for files of the generated package, changing the absolute paths to relative ones. The root folder is the top-level folder in the folder tree.</p> <p>At that:</p> <ul style="list-style-type: none"> <li>• Relative paths do not change. Relative paths specified outside the original root folder are saved up to first-level folder above them and are located in the root folder;</li> <li>• Absolute paths outside the root folder tree are converted to relative ones. Absolute paths not included in the original root folder are saved up to the path to the first-level folder above them and are located in the root folder;</li> <li>• Absolute paths outside the root folder tree are converted to “No path specified” and transferred to the root folder or a folder inside the root folder tree; If necessary, missing folders can be created.</li> </ul>
	<b>Place all files in one folder</b>	Places all files, including drawings, images and fonts to the same folder.
	<b>Keep files and folders as is</b>	Creates folders structure as in the original document

## Default Raster Properties

 The section for setting the default raster image properties. These options are used to display a raster when they are not explicitly set. For example, when opening a raster image that does not have a resolution value.

	<b>DPI &lt;300&gt;</b>	Default resolution for images doesn't contains resolution.
	<b>Transparency</b>	Enables/disables transparency mode for monochrome images.



## Georeferencing

 Section for setting georeferences of raster images.

<input checked="" type="checkbox"/> 	<b>Use World or TAF file</b>	<p>Using World or TAF file when inserting raster images.</p> <p>Inserting georeferenced raster images in World or TAF georeferencing files, if any. When inserting such rasters, the coordinates of the insertion point, the scale and the rotation angle are substituted automatically.</p> <p>It also creates a World file with geo-coordinates for each Raster image saved from the <a href="#">External References Manager</a> using the <b>Save as</b> command from the context menu</p>
---	------------------------------	---











## PDF Units



 PDF measurement units to be used when inserting PDF as underlays and importing PDF, where measurement units are not specified.

<input checked="" type="radio"/> 	<b>Inches</b>	Using inches.
<input type="radio"/> 	<b>Millimeters</b>	Using millimeters.

## Licensing



 Section for setting licensing parameters of the program and its modules.

<input type="checkbox"/> 	<b>Modules</b>	Section for managing the availability of the program modules.
<input type="checkbox"/> 	<i>3D geometric modeler and constraints</i>	Section for switching the used geometric 3D kernel and constraints.
<input checked="" type="radio"/> 	<b>C3D</b>	Using 3D geometric kernel.
<input checked="" type="checkbox"/> 	<b>3D modeler, 2D and 3D Constraints (C3D)</b>	Enables/Disables loading 3D modeling modules, 2D and 3D constraints on C3D kernel.
<input type="checkbox"/> 	<i>Platform mode</i>	
<input checked="" type="radio"/> 	<b>Common</b>	nanoCAD Plus
<input type="radio"/> 	<b>Construction</b>	nanoCAD Plus with SPDS module
<input type="radio"/> 	<b>Mechanica</b>	nanoCAD Plus with Mechanica module
<input checked="" type="checkbox"/> 	<b>Raster tools</b>	Enables/Disables loading of <b>Raster</b> module, which includes full functionality for work with raster images and some commands for work with point clouds. When the module loading is disabled in the <b>Point clouds</b> and <b>Raster</b> main menu items (as well as in the corresponding ribbon tabs) only the basic functionality will be available: rotations, skew elimination, correction, pencil and eraser functions.
<input checked="" type="checkbox"/> 	<b>Topoplan</b>	Enables/Disables loading of the <b>Topoplan</b> module, which includes functionality for editing topographic plans.

	<b>Request the product license before corporate</b>	Determines the order of requesting the license: first product, then corporate ones, or first corporate and then product ones.
	<b>Request "Engineering BIM" license first</b>	Determines the order of requesting the license: first "Engineering BIM" and then product and corporate ones.

## Profiles

 Ribbon: **Manage – Customization** –  drop-down list >  **Profiles**

 Button  in the [Options](#) dialog.

 Command Line: **PROFILES**

A Profile is a set of custom settings with a unique name for working environment parameters. By default, nanoCAD saves all current settings in <<Default>> profile.

If several users, using one account to enter the system, work with the program, each of them can create a profile and load it for working. Another example of profile usage is for quickly switching between settings when working with different documents in the current session.

Only one profile can be current. When changing interface settings, the current profile is changed automatically.

To use the custom settings of the working environment on other computers, a profile can be saved in a file with a \*.wip extension. A *WIP-file* loaded on the other computer changes only the setting of the current profile, which were saved in this file. Other settings remain unchanged.

A section of the [Options](#) dialog contains:

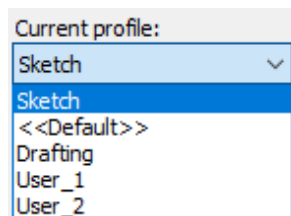

List with names of profiles available in the current document.  
The profile selected in the list becomes the current one.



The button opens the Profile dialog box to create and manage profiles.

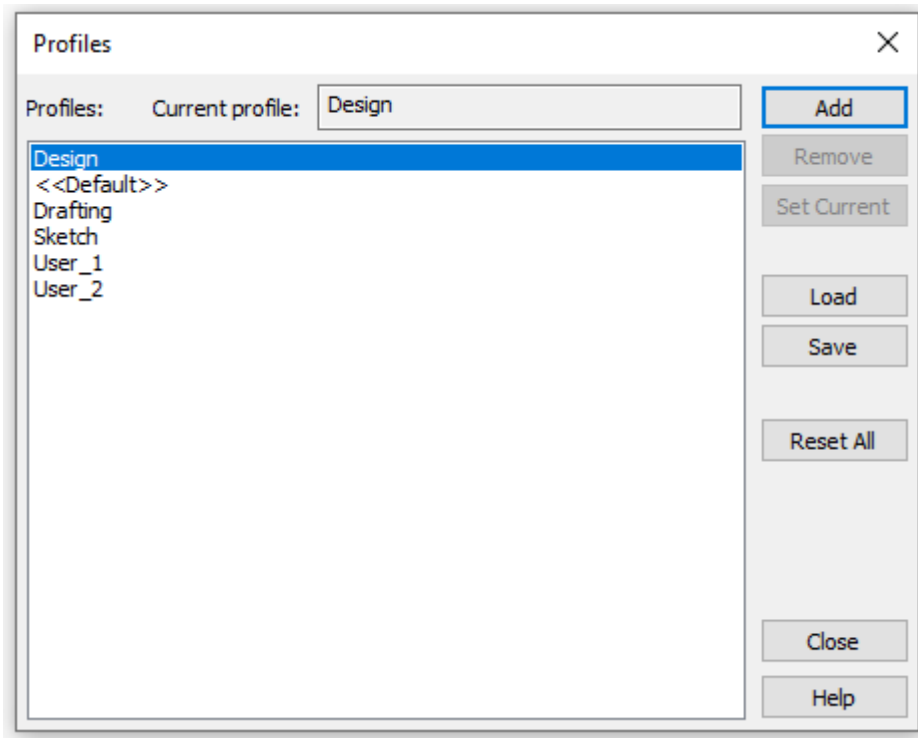

The list of all profiles is shown in the **Profiles** section.

The name of the current profile is shown in the **Current profile** field.

A new profile inherits the properties of the current profile.

To set a selected profile as the current one, select the **Set Current** button.

To delete a selected profile from the list, select the **Remove** button.

The **Reset All** button deletes all profiles and recovers the standard nanoCAD profile. Changes take effect after restarting the program.

**ATTENTION!** Before applying the **Reset All** button, save user profiles or they will be deleted.

#### *To create a new profile:*

1. In the  **Options** dialog box, click the button.
2. In the **Profiles** dialog select the **Add** button.
3. In the **Add Profile** dialog box specify a name for the new profile and select the required check boxes:

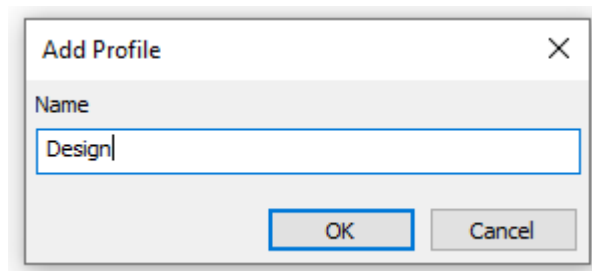

4. Select **OK**. The name of the created profile will be shown in the list of profiles.
5. Select the **Close** button to close the dialog box.

#### *To save a profile:*

1. Select the profile to save.

2. Select the **Save** button.
3. In the **Add Profile** dialog box specify a name for the new profile and select the required check boxes.
4. Select **OK**.
5. In the **Save As** dialog box specify the name and the folder location to save the profile, after that select the **Save** button.
6. Select the **Close** button to close the dialog box.

**To load a profile from other computer:**

1. Select the **Load** button.
2. In the **Open** dialog box select the nanoCAD profile.
3. Select the **Open** button. The file will be added to the profiles list and set as the current one.
4. Select the **Close** button to close the dialog box.

**ATTENTION!** You can replace the profile only among one nanoCAD version. When you replace the profile from one program version into another version troubles with interface might occur.

## Profile Quick Setting



Command line: **QUICKPROFILE**

The command opens the dialog for quick access to profile settings. Using this command you can set a current profile or create a new profile.

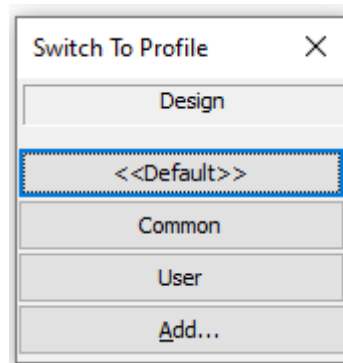

The **Switch to Profile** dialog contains a list of profiles, created or loaded in the current program session.

To set a profile current select a button with its name.

The **Add** button opens the **Add Profile** dialog to create a new profile.

## Graphic Subsystem Settings

nanoCAD provides a wide variety of settings to adjust graphic subsystem, from selecting the video adapter graphics library, to configure different cases of graphic displaying in the drawing.

You can set up graphics settings in the **Graphics settings** section of the **Options** dialog.

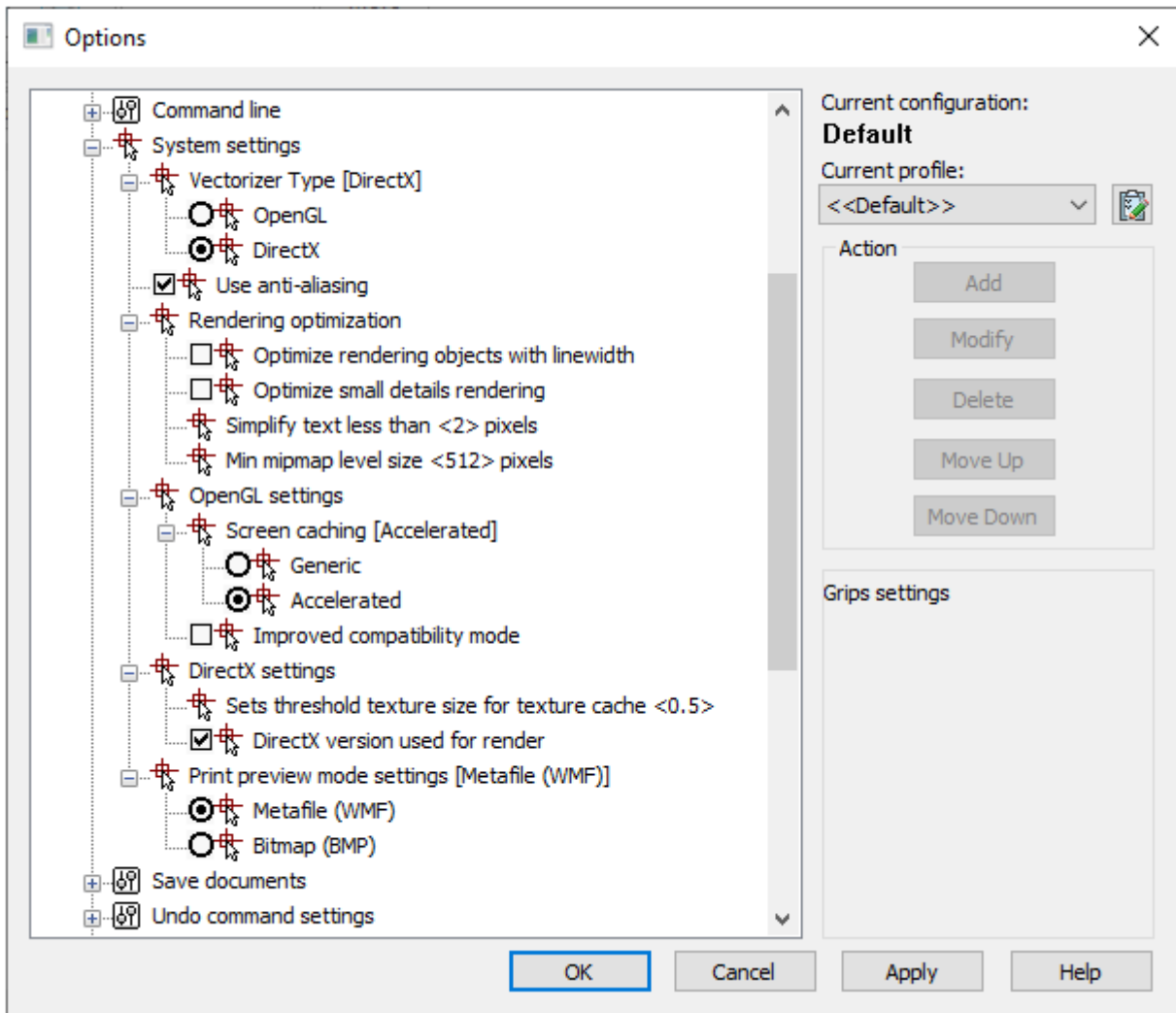

## Graphics Hardware Acceleration Settings

For correct and fast graphics displaying in a workspace, you can specify the way of nanoCAD interaction with PC's graphics hardware accelerator and settings of the selected method.

The main ways the program interacts with the PC video subsystem are:

- use of OpenGL;
- use of DirectX;

software emulation in OpenGL mode (High Compatibility Mode).

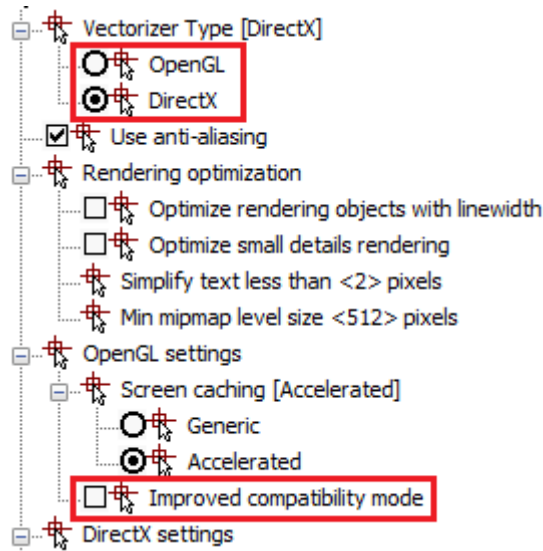

There are special settings for every mode of interaction. OpenGL graphics library is set by default. This mode provides 3 OpenGL settings sets, which should be switched depending on the PC's video adapter performance.

For the first time you should use autocheck of system performance of graphic system.

## *Automatic Adjustment of Graphic Hardware Acceleration*

The program graphic subsystem might work slowly or become unstable with some video adapters and driver versions. For example, the cursor in the empty drawing moves unevenly or isn't shown. In this case it is worth to estimate performance of PC video subsystem with automatic determination of the optimal set of graphics settings.



-Menu: **Help** –  **Video Subsystem performance check**



Command line: **VPERFTEST**

**NOTE:** It is better to close all running programs to get correct test results.

After running the command, a window opens containing recommendations that must be followed to properly test the graphics subsystem.

The **Test** button starts the process of assessing the performance of the computer's graphics subsystem.

When the test is finished, the dialog with the results is shown:

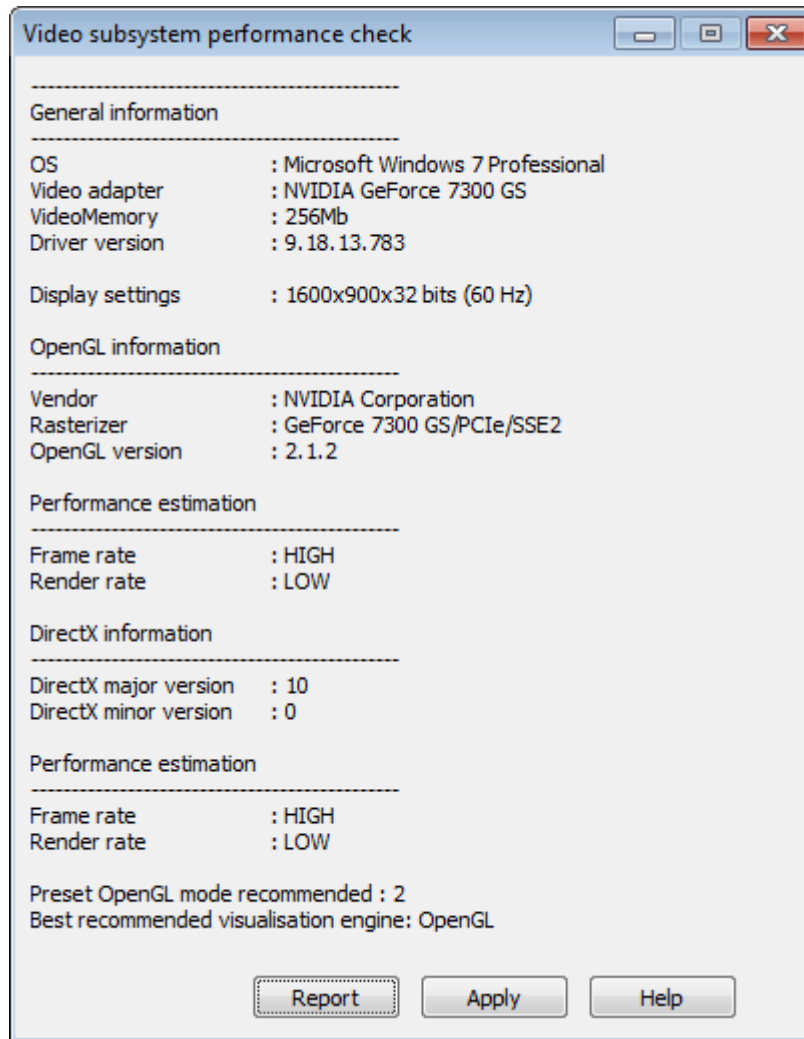

The **Report** button is used to save the results of testing in a separate file.

To save the report in a separate file, click **OK** in the report window and specify the storage path.

**Apply** button enacts Graphics hardware acceleration settings that were recommended after automatic testing, and shows following message:

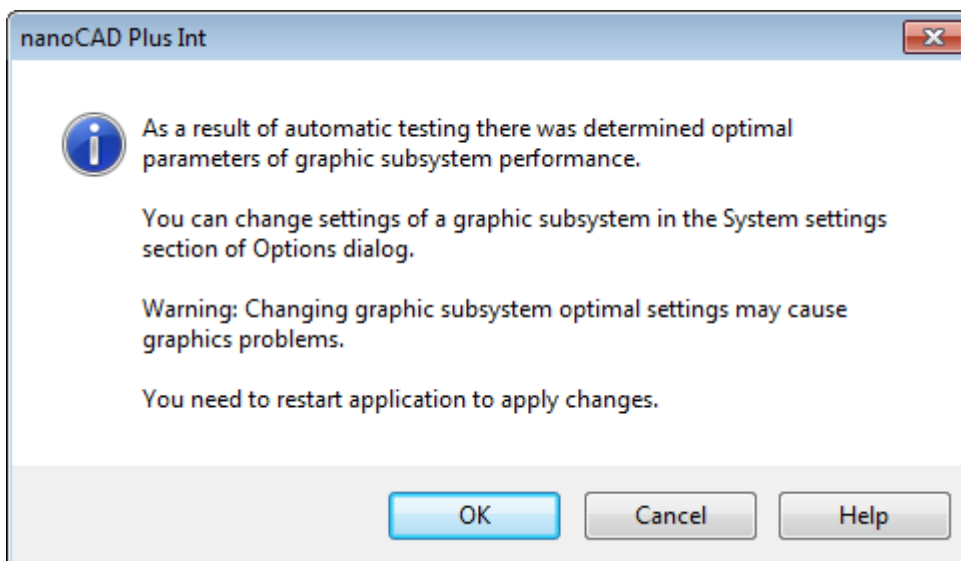

Click **OK** and restart nanoCAD to apply settings.

**NOTE:** In case you click **Cancel** button, the settings recommended based on the results of automatic testing will not be applied.



The command can change only the following Graphics hardware acceleration settings:

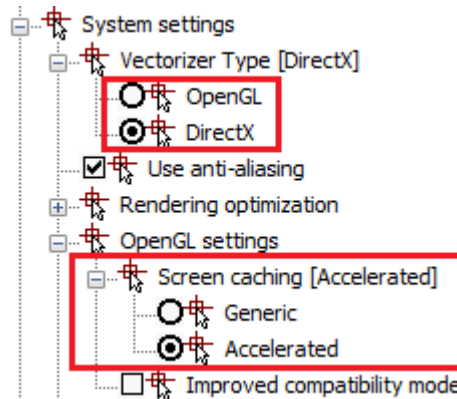

Other options will not be changed. You should change them in **Option** dialog manually.

## OpenGL Manual Adjustment

These settings can be changed manually in the **Graphic settings** section – **OpenGL settings - Graphics hardware acceleration settings** of the **Options** dialog:

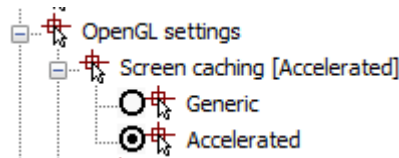

*For manual OpenGL adjustment, do the following:*

1. Save all changes, close all drawings that you are editing.
2. Open the **Options** dialog box (menu **Tools – Options**).
3. Open the **System settings** section – **Vectorizer Type [OpenGL]** and make sure that **OpenGL** is selected.

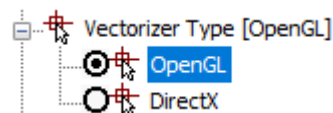

4. Open the **OpenGL settings** section – **Screen caching [Accelerated]**:

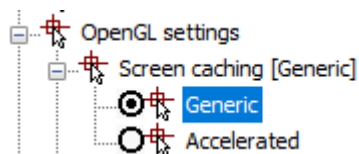

5. Select the setting variant different from the current one: **Generic** item or **Accelerated** item.
6. Click **OK**.
7. Open a new document and assess the speed of cursor movement.

## DirectX Manual Adjustment

You can use DirectX instead of OpenGL graphics library.

Switch to **DirectX** in the **Graphic settings - OpenGL/DirectX** section of the **Options** dialog.

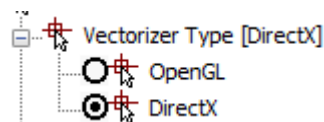

By default, when DirectX is selected, DirectX 11 is activated. If it is not supported by the system, then DirectX 9 is activated. You can change DirectX version manually by **DirectX Version** option in DirectX settings or NCGS\_TOGGLE\_DIRECTX command.

### Sets threshold texture size for texture cache <...>

You can specify additional mode options in the **DirectX settings** section.

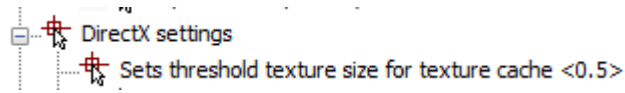

Displaying of small raster images is quicker when the image is saved in computer graphic memory. This coefficient limits the size of raster images that will be saved in graphic memory. The image is suitable if its largest size (vertically and horizontally) is less than the following value: the size of graphic memory multiplied by this coefficient. The coefficient is fractional number between 0.1 and 0.5.

### DirectX Version

You can switch the used DirectX version in the **DirectX settings** section.

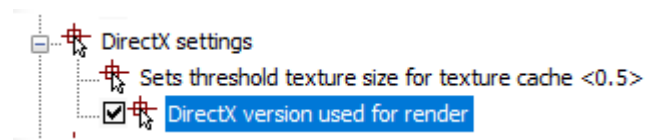

If the box is checked, then DirectX 9 is used.

When the box is not checked, the default DirectX version is used. In most cases, it is DirectX 11, but if it is not supported by the system (for example, RDP connections), then it is DirectX 9.

You can also switch DirectX version by NCGS\_TOGGLE\_DIRECTX command.

## Graphic Subsystem Common Settings

After you have configured hardware interaction settings, you can configure other parameters of graphic subsystem. Discussed in this section, graphic subsystem settings are relevant for any type of hardware interaction – OpenGL / DirectX / OpenGL software emulation mode.

### Antialiasing

Enable **Use anti-aliasing** check-box to smooth lines on the drawing:

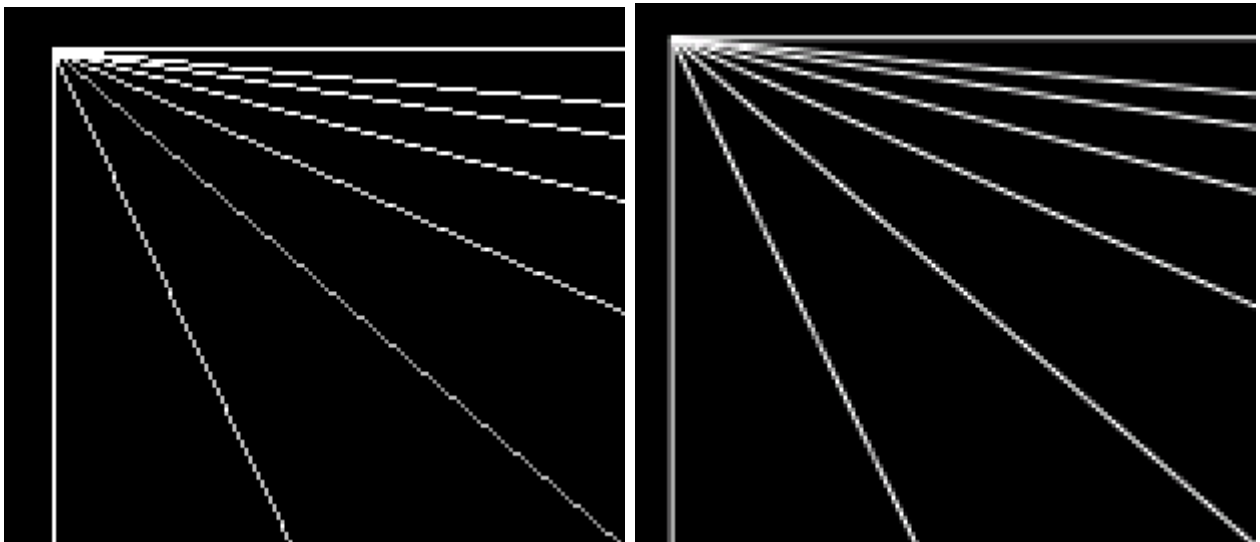

Anti-aliasing does not work when *Improved compatibility mode* is enabled.

## Rendering optimization

### Optimize meshes rendering

Turn off displaying of solid text and hatch during document navigation (zoom, pan etc.).

### Optimize rendering objects with linewidth

Turn off displaying of linewidth during document navigation (zoom, pan etc.).

### Optimize text rendering

Turn off displaying of weight of bounding rectangles for the text during document navigation (zoom, pan etc.). Bounding rectangles are shown when Quick text (QTEXT) mode or **Simplify text less than <...> pixels** option is turned on.

### Optimize small details rendering

Disable points and other graphic with the same size in navigation mode – Zoom, Pan, etc.

### Simplify text less than <...> pixels

You can set the height of the text displaying in pixels. If the height of text object is less than this value, then it displays as the bounding rectangle of the text object.

 Simplify text less than <2> pixels

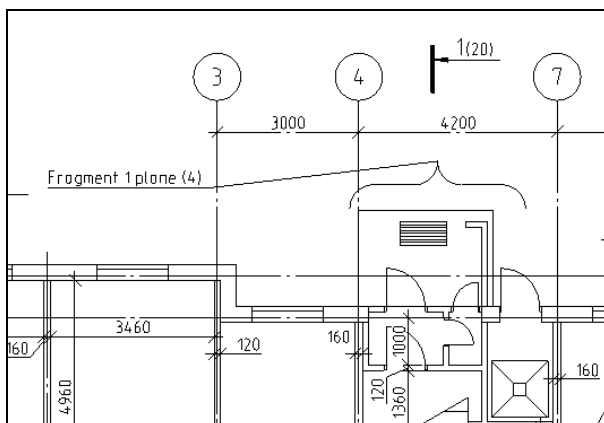

**Simplify text mode is disabled**

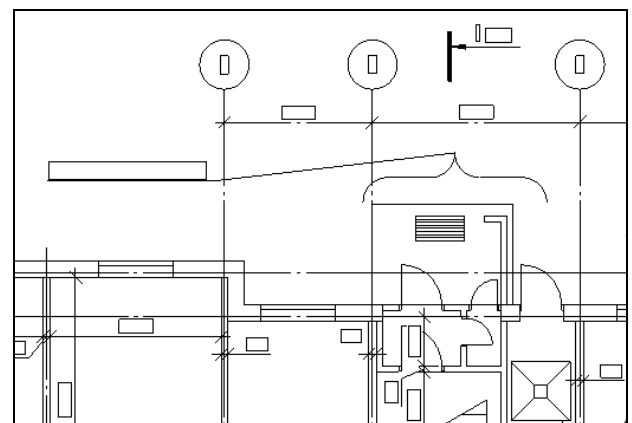



**Simplify text mode is enabled**

Renew the drawing to changes take effect.

### Graphics displaying for very large drawings

If a drawing has a large size (the values of the cursor's coordinates are 3000000 or higher), perhaps you need to switch on the following parameters to correct the graphics displaying:

-  Separate display cache for ModelSpace views
-  Separate display cache for PaperSpace views

## Improved Compatibility Mode

If none of OpenGL and DirectX settings does not give an acceptable displaying quality, you can try to enable the *improved compatibility mode*.

The **Improved compatibility mode** emulates OpenGL with built-in Windows software tools and allows not taking into account PC's hardware video accelerator.

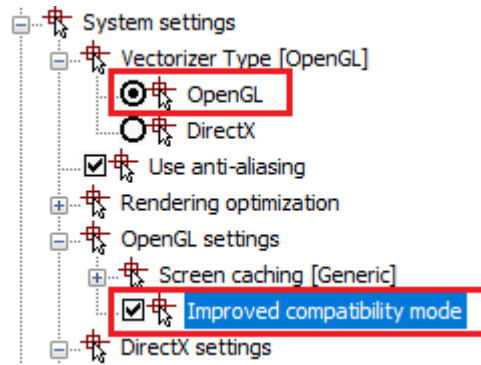

To enable this mode set **OpenGL** mode and enable **Improved compatibility mode** checkbox.

Usage of improved compatibility mode can significantly slow the process of image redrawing on the screen, therefore it is expedient to turn it on in cases, when it is acceptable to sacrifice display speed in favor of quality.

A number of graphical display do not work in this mode, including **Anti-aliasing**.

## Customize User Interface



Ribbon: **Manage – Customization – Interface** >  **Customize interface**



Menu: **Tools – Customize** >  **Interface...**









Command line: **INTERFACE**

**Customize User Interface** dialog box is intended to:

- create and edit new menus, toolbars, context menus;
- fill menus and toolbars by commands;
- create new commands;
- add and change actions on objects, accelerators, aliases, tooltips;
- save all changes in a separate .cfg file and manage configuration files.

### Dialog options

<b>File name</b>	The field displays the path and name of the CFG file being edited. By default, the current configuration file is opened.
<b>File</b>	Drop-down menu with configuration file management commands.
 <b>Open</b>	Opens a dialog to search for and open a <b>configuration file</b> with *.cfg <b>extension</b> .
 <b>Add new partial file</b>	Creates a custom partial configuration file.
 <b>Load partial file</b>	Connecting a partial configuration file to the main configuration file (master file).
 <b>Unload current partial file</b>	Disconnects the current partial configuration file.
<b>Import keyboard shortcuts</b>	Loading keyboard shortcuts (combinations of “hot” keys for quickly calling nanoCAD commands).
 <b>Save</b>	Saves the current configuration file.
 <b>Save as...</b>	Saves the current configuration file under a different name.



**Exit**

Exit the dialogue.

**Customize User Interface** dialog contains 9 tabs:

- **Ribbon**
- **Main menus**
- **Toolbars**
- **Status bar**
- **Popup menus**
- **Accelerators**
- **Object actions**
- **Rollover tooltips**
- **Aliases**

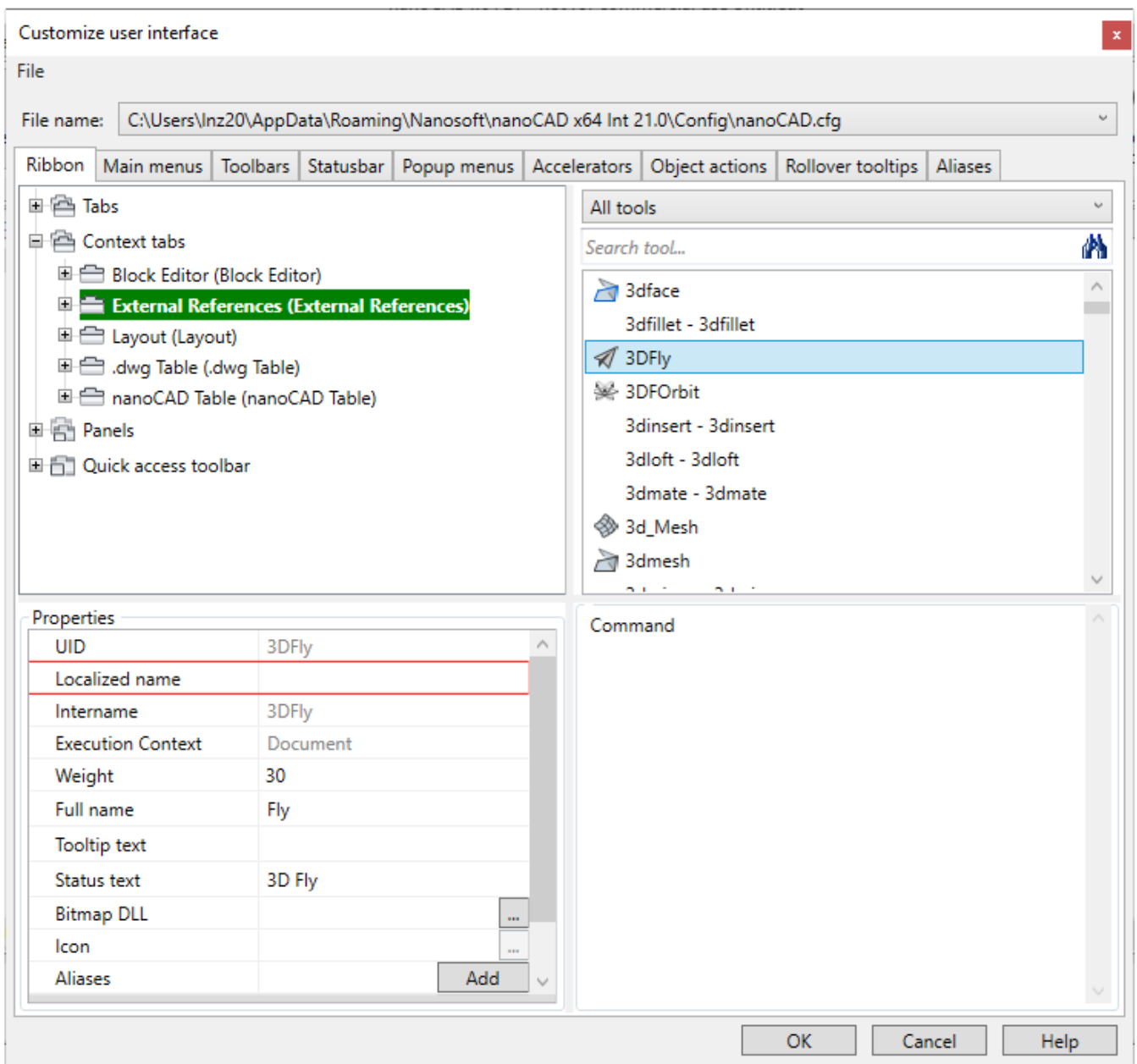

### Parameters

**File name**

Field displays the path and name of edited CFG-file.

**File**

Commands to manage config files:

- **Open**
- **Load partial file**
- **Upload current partial file**
- **Save**
- **Save as...**
- **Clear**
- **Exit**

Upper left part of dialog displays all elements of opened tab. Move selected element with drag&drop.

Upper right part of dialog contains all nanoCAD tools: commands and controls. Use them to create and edit interface objects: menus, toolbars, status bar.

There is a filter for tools:

- Select a section to display elements of selected category.
- Or type the template to find appropriated tools

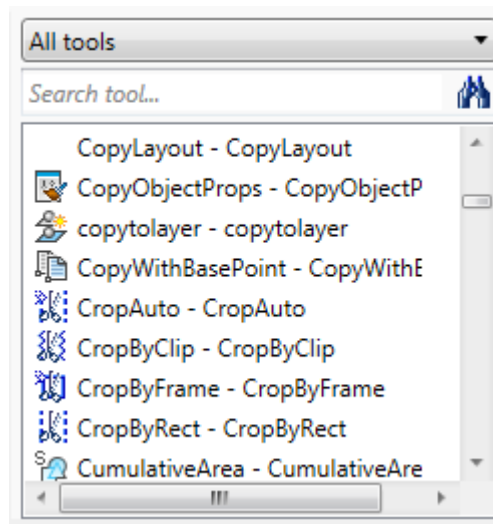

Information about the selected element and action to be done with it is displayed in the right bottom corner of the dialog box.

**Properties** in the lower left part of dialog displays properties of selected elements; they can be edited.

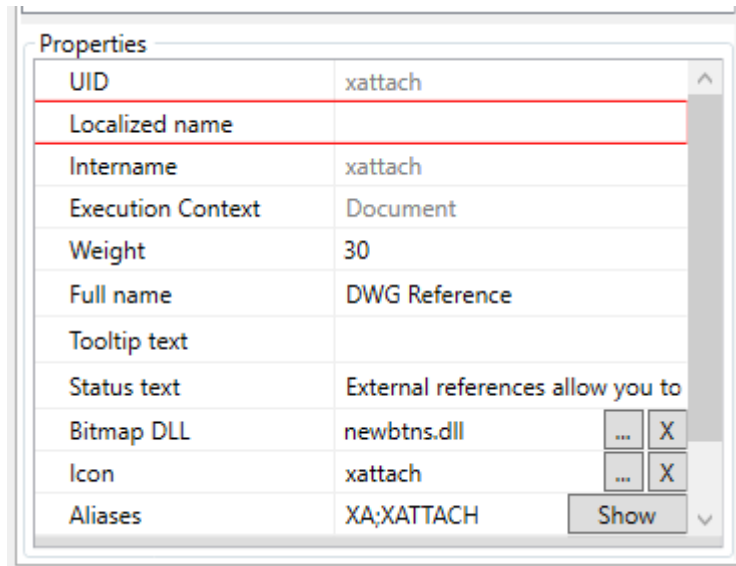

It is possible to edit and create interface elements in a context menu.

**ATTENTION!** You should restart nanoCAD to apply changes made in the current configuration file. Use **SETCONFIG** command to load another configuration file.

**NOTE:** The interface settings can be transferred and copied with the **UIIMPORT** and **UIEXPORT** commands.

The process of creating a custom menu, toolbar and ribbon with examples is described in the article "Creating a custom menu, toolbar and ribbon in nanoCAD", located on the official Nanosoft development website.

## Ribbon Tab

The tab is intended to edit the ribbon.

In the left upper part, there is a tree of ribbon elements, which presents all its tabs, context tabs, panels and commands.

A ribbon element is created and edited through its context menu. The composition of context menu commands depends on the selected tree element. The element is moved by dragging it in the ribbon tree. You can add a new command in the ribbon by dragging it from the command list in the right part of the dialog.

**ATTENTION!** To apply changes in the ribbon elements, use **RELOADRIBBON** command or hot keys **ALT+R**. It is not required to reboot the program.

## Tabs

The ribbon contains a set of tabs on which controls and tools for creating and editing a drawing are compactly grouped.

### Create a new tab

1. A new tab is added by selecting **Add tab** command from the context menu of **Tabs** section in the ribbon elements tree.

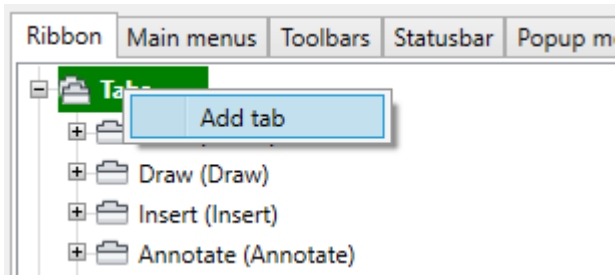

Upon the completion of all data entry, the tab will appear in the end of all tabs list. To add a new tab immediately before the existing one, select the desired tab in the ribbon tree and select **Insert tab** in the context menu.

2. In the emerged **Create ribbon tab** dialog, fill the boxes

<b>UID</b>	Element identifier in the program.
<b>Name</b>	Internal name of the tab.
<b>Text</b>	Name of the tab to be displayed on the screen.

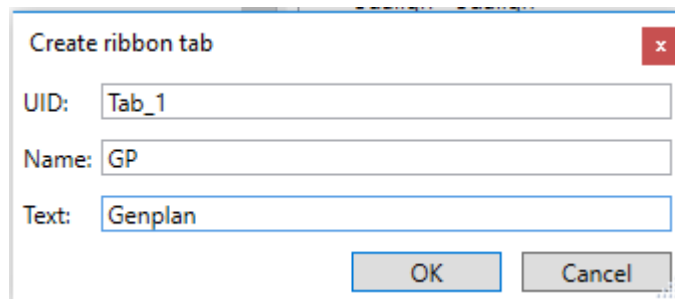

3. Click **OK**.

You can move any tab in the tree by a simple drag-and-drop.

### *Create tab elements*

There may be panels inside a tab. Each tab should obligatory contain at least one panel.

1. Select a tab in the tree list.
2. In the context menu, select a command to create the desired element:
  - **Add new panel**
  - **Add existing panel**

#### *Add new panel*

1. Select the command in the context menu.
2. Fill parameters in the **Create ribbon panel** dialog box, click **OK**.

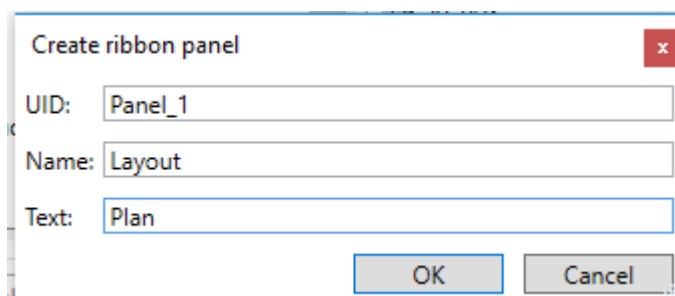

#### *Add existing panel*

1. Select the command in the context menu.



2. Select the element in the **Select panel** dialog box, click **OK**.

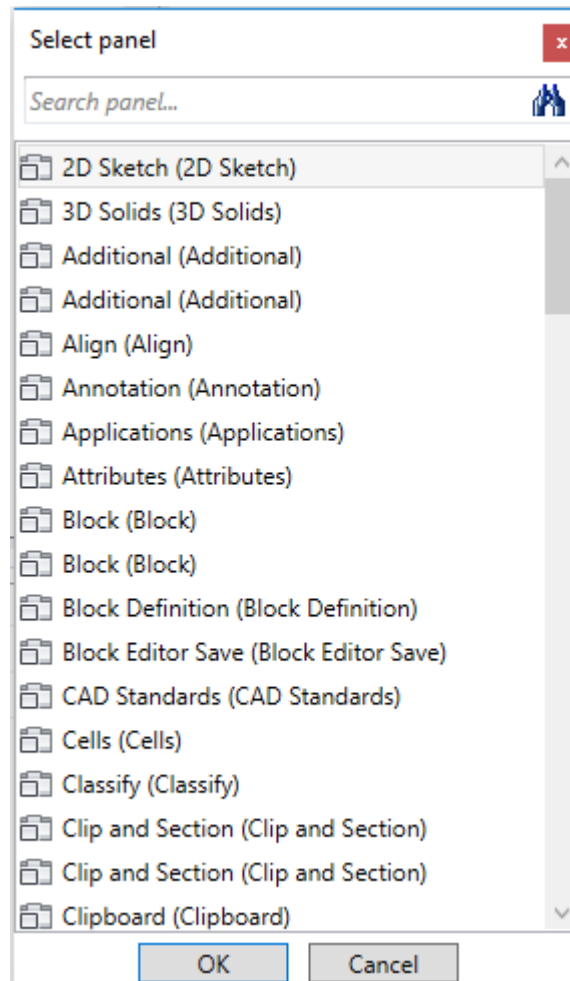

### **Context tabs**

Context tabs become visible under certain conditions. For example, **Layout** appears only upon transfer to the paper space, **Block Editor** – when you enter block editing mode. It is impossible to add/remove context tabs. Context tab elements are created similarly to tab elements.

## **Panels**

In each ribbon tab elements are grouped in panels – sets of commands similar in function.

### **Create new panel**

Each tab should contain at least one panel. A panel can be added only to a tab or a context tab.

1. A new panel is added by selecting the **Add new panel** command from the context menu of the **Panels** section in the ribbon elements tree.
2. Fill the boxes in the **Create ribbon panel** dialog

<b>UID</b>	Element identifier in the program.
<b>Name</b>	Internal name of the panel.
<b>Text</b>	Name of the panel to be displayed on the screen.

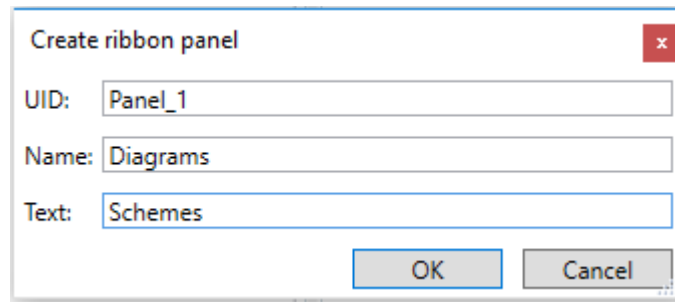

3. Click **OK**.

### *Create panel elements*

A panel can contain:

- Rows inside of which there are command buttons, lists and other interface elements;
- One panel's dialog box that opens by  button;
- Hidden rows separator.

To fill a panel with elements, it is necessary to create at least one row.

1. Select the panel in the tree list.
2. In the context menu, select the command to create a desired element:
  - **Add row**
  - **Add dialog box launcher**
  - **Add hidden rows separator**

### *Add dialog box launcher*

A dialog box launcher is a button with an arrow  located in the right lower corner of some panels and intended

1. To select the **Add dialog box launcher** command in the panels' context menu.
2. In the **Create dialog box launcher** dialog box, to assign the command for **Dialog box** button, click  button.

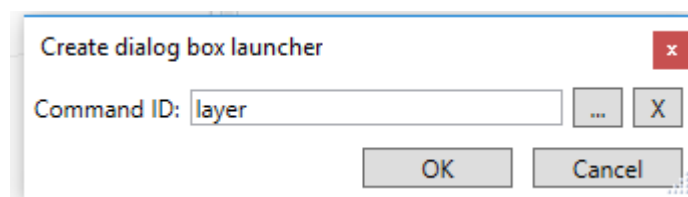

3. Select the required command in the **Command ID** dialog box. Click **OK**.

### *Add hidden rows separator*

A separator is an arrow  in a panel name, it unfolds the display of additional panel elements. You can create a separator through the context menu by selecting the **Add separator**.

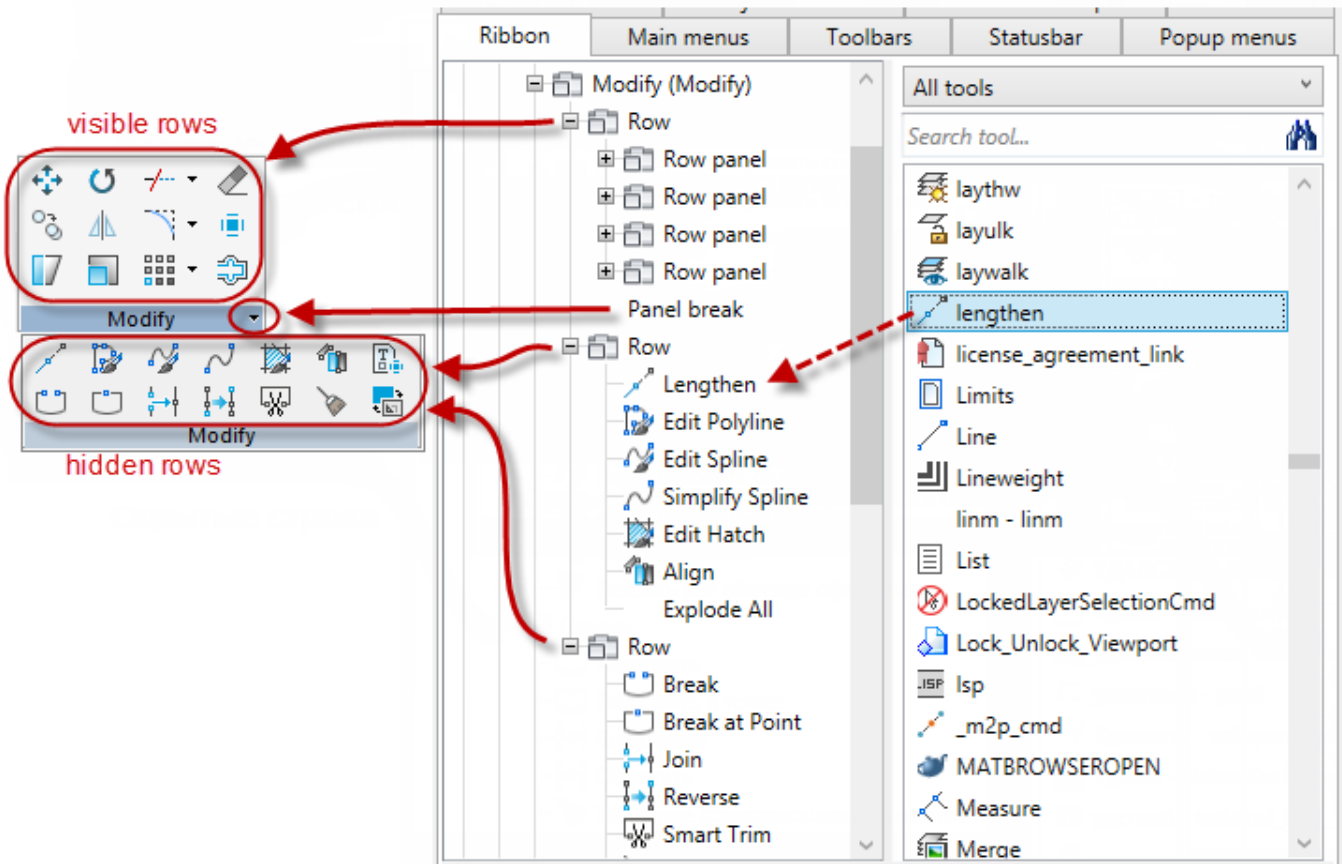

## Rows

A tool row is a set of commands situated in a panel in one row.

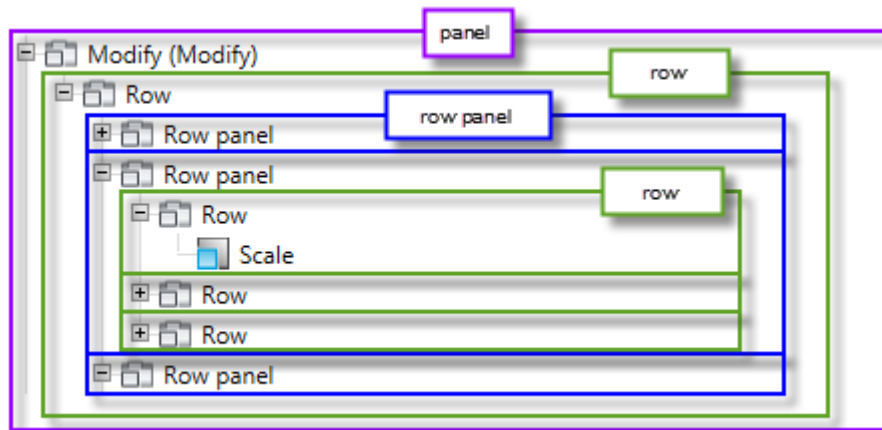

### Create row elements

Row may include row panels, buttons, split buttons and separators.

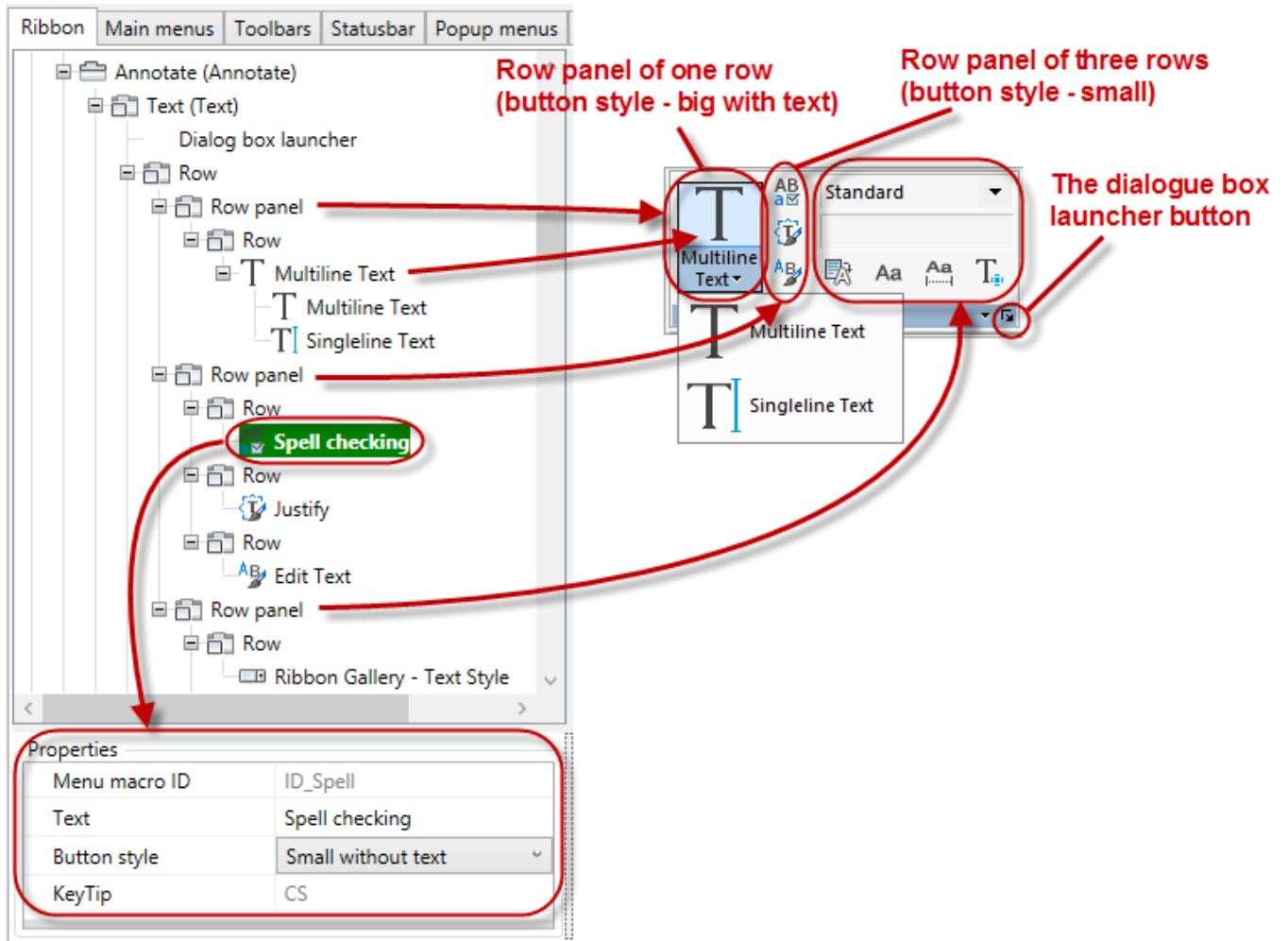

1. Select a row in a tree list.
2. In the context menu select the command to create a desired element:
  - **Add button**
  - **Add split button**
  - **Add row panel**

### Add row panel

A row panel is added when it is necessary to divide a group into several vertical parts with different number of rows. A row panel can be added only inside a row.

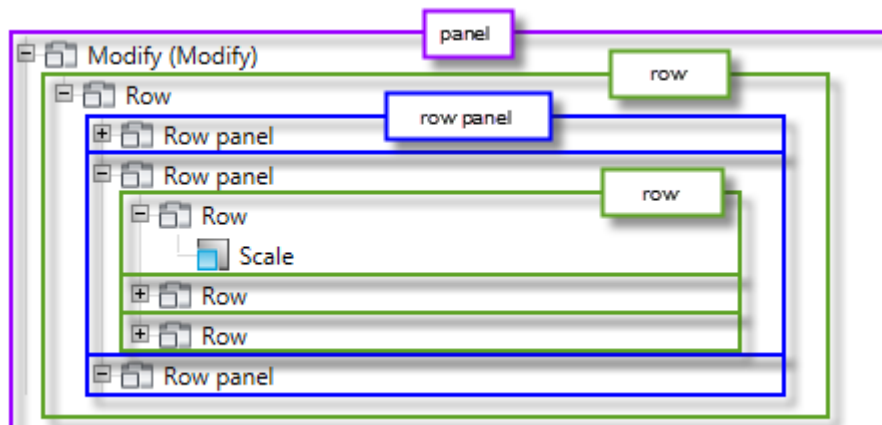

### Add button

A button can be added in a row by dragging a command from the command list on the right, as well as through the context menu.

1. Select the **Add button** command in the row's content menu.
2. Set parameters in the **Create ribbon button** dialog box.

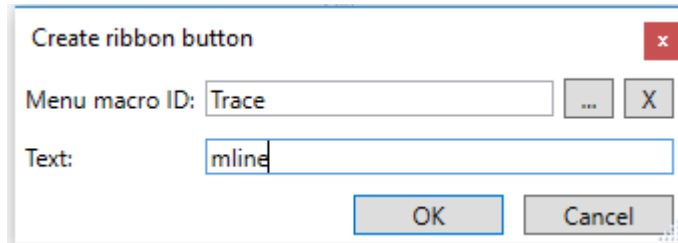

3. To assign command to the button, click  button next to **Menu macro ID** field.
4. Select the required command in the **Select command** dialog box. Click **OK**.

### Add split button

1. Select the **Add split button** command in the row's context menu.
2. Set parameters in the **Create ribbon dropdown** dialog box.

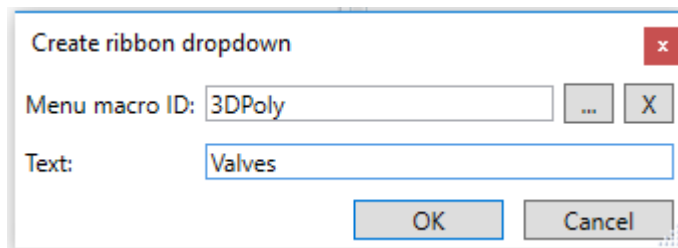

3. To assign command to the button, click  button next to **Menu macro ID** field.
4. Select the required command in the **Select command** dialog box. Click **OK**.

You can add buttons in the dropdown list by dragging commands from the command list on the right or through the **Add button** command of the context menu. Parameters of the drop-down list can be changed in the **Properties** field.

### Filling rows with commands

1. Select the command in the right window of the tools list.
2. Drag it to the required row in the ribbon elements tree.

### Add separator

A separator is a line or a spacing that are added in a panel, row panel, hidden rows, dropdown list for visual separation of commands.

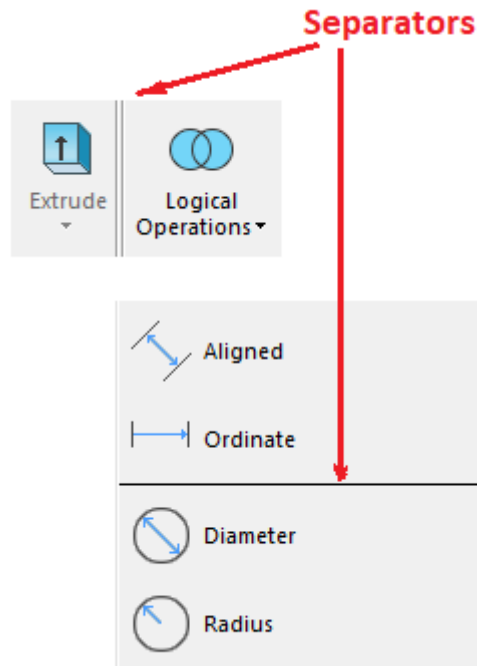

1. Select the list row to place the separator before.
2. Select **Add separator** in the context menu.

## Quick Access Toolbar

The Quick Access Toolbar is located at the top or bottom of the Ribbon and contains buttons for the most frequently used commands.

A button can be added to the Quick Access Toolbar by dragging a command from the list of commands on the right, or through the **Add Button** command in the context menu:

1. In the **Create Ribbon Button** dialog, click the  button next to the **Menu macro ID** field.
2. Select the desired command in the **Select a command** dialog. Click **OK**.
3. If necessary, correct the **Text** field. Click **OK**.

If you select a specific button and use the **Insert Button** context menu command, the new button will be located immediately before the selected one.

## Deleting Elements

1. Select the required element in the tree.
2. Use the **Delete** command of the context menu.

## Main Menu

Create custom and edit existing menus using context menu of element.

All menus used in the program are presented in the tree list.

The commands to create and edit menus are called from the context menu. Composition of the context menu commands depends on the selected tree object.

## Create Custom Menu

1. To open the **Create menu** context menu, select the top line of the **Main menu** tree (or right click in the list window). If you select a certain menu and use the **Insert menu** context menu command, a new menu will be located directly before the selected one.
2. Fill fields in a **Create menu** dialog:

**UID** Element identifier in the program.  
**Display name** Displayed name on the screen.

3. Press **OK**.

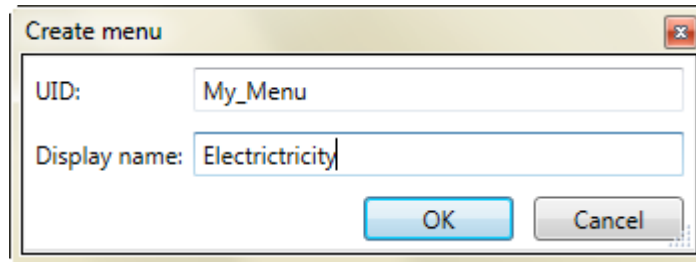

New menu appears in the end of the list of elements. Move them using drag and drop.

### Create elements of menu

1. Select the desired menu in the list of menus.
2. Select one of the items:
  - **Add menu item**
  - **Add submenu**
  - **Add separator**

### Add submenu

1. Select **Add submenu**.
2. Fill fields in the **Create menu** dialog, press **OK**.

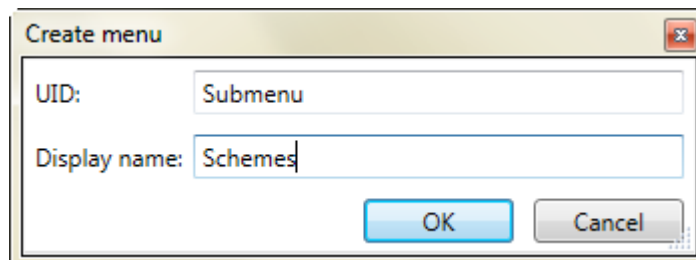

### Add menu item

Menu item is a command in the menu list.

1. Select **Add menu item**.
2. Fill fields in a **Create menu item** dialog.

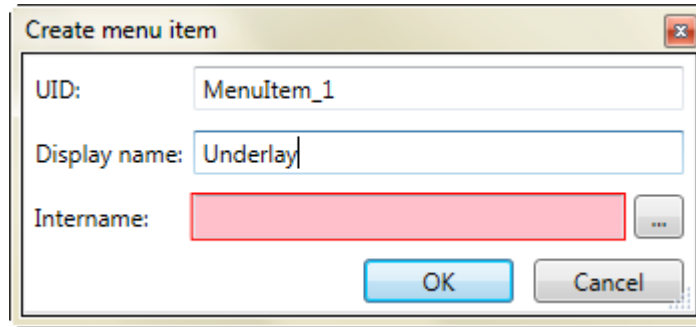

3. Click the  button to add the command.
4. Select the desired command in a **Select command** dialog box. Press **OK**

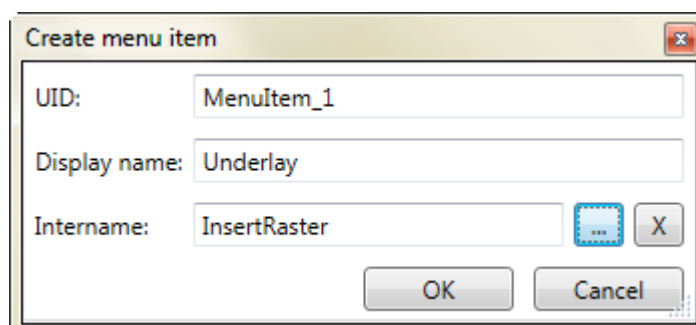
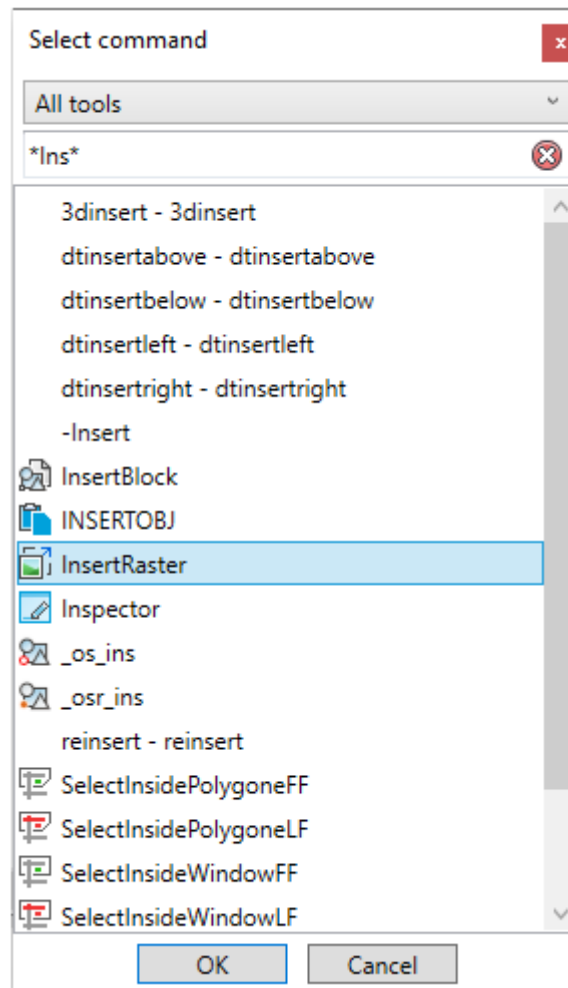

 button clears the field.



### Add separator

Separator looks like a line in menu, submenu, toolbar, statusbar. Used to split commands by groups.

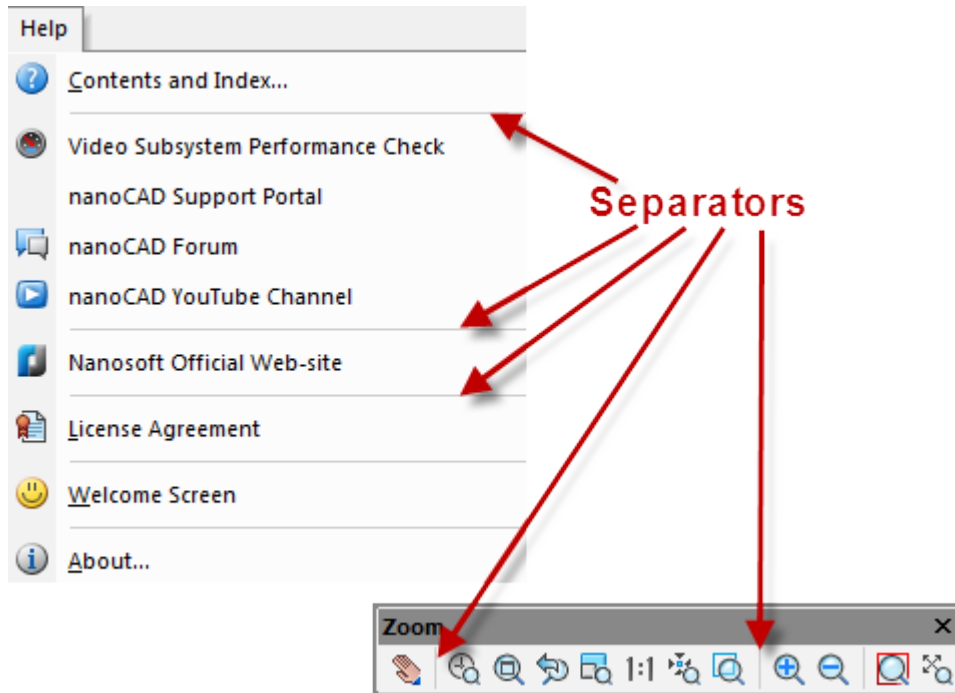

1. Select the menu bar to insert separator above.
2. Select **Add separator** in the context menu

### Add commands into menu and submenu

1. Select the command from the right list.
2. Drag it and drop to menu at the left part of dialog.

### Remove elements and menus

1. Select the desired element or menu.
2. Use **Delete** command in the context menu.

## Toolbars Tab

Create custom toolbars and edit existing. It is possible to add commands, drop-down lists, controls and separators. Properties of selected toolbar are displayed in the Properties:

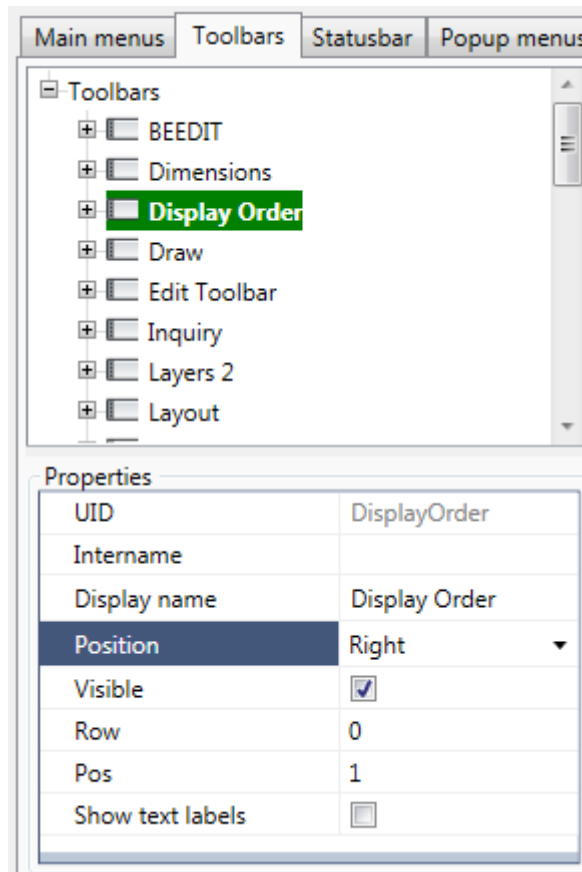

## Create New Toolbar

1. To open the **Create toolbar** context menu, select the upper line of the **Toolbars** tree list ( or click the right mouse button in the list window). If you select a certain toolbar and use the **Add toolbar** context menu command, a new toolbar will be located directly before the selected one
2. Fill fields in a **Create toolbar** dialog box.
3. Click **OK**.

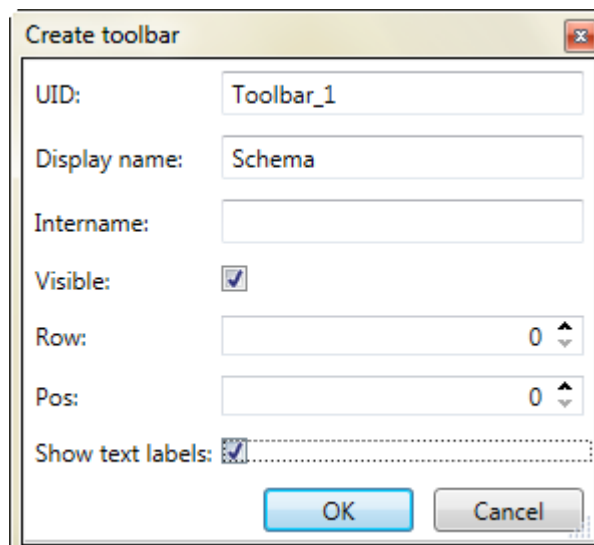

### Parameters

- UID** Element identifier.
- Display name** Displayed name of toolbar.

<b>Position</b>	Position on the screen.
<b>Visible</b>	Turns on/off visibility of toolbar.
<b>Row</b>	Row for fixed toolbar.
<b>Pos</b>	Position in the row of fixed toolbar.
<b>Show text labels</b>	Turns on/off the display of text labels on buttons of the selected toolbar.

Depending on the selected **Show text labels** mode, *floating* (located in graphic area) toolbars have different appearance:

The **Show text labels** box is clear



The **Show text labels** box is checked

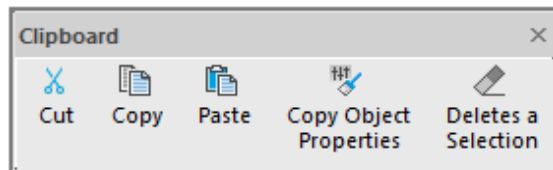

### Add an element into toolbar

1. Select toolbar in the list.
2. Call context menu and select one of items:

- **Insert button**
- **Insert control**
- **Insert flyout**
- **Insert separator**

3. Fill fields in dialog box.

### Add button

1. Select **Insert button** command.
2. Set **Display name** in the **Create toolbar button** dialog box.
3. Click  button near Intername.
4. Select the desired command. Click **OK**.

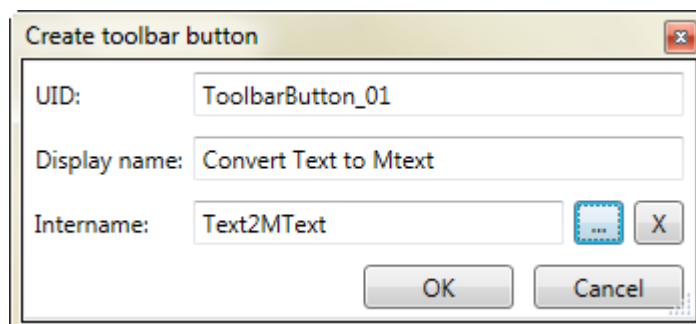

It is possible to drag and drop command to add button into toolbar.

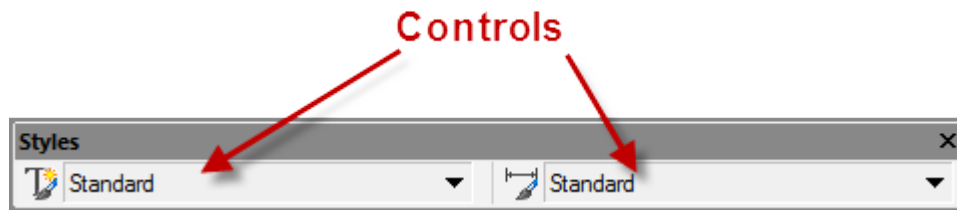

### Add control



Drag and drop control from the list to add it into toolbar.

1. Select **Insert control** command.
2. Set **Display name** in the **Create toolbar control** dialog box.
3. Click the  button near **Control** field.
4. Select the desired control in a **Select control** dialog box. Click **OK**.

### Add drop-down toolbar

1. Select the **Add toolbar** command.
2. In the **Create toolbar flyout** dialog click the  button next to the **Main command** field.
3. Select the command in the **Select command** dialog. Click **OK**.
4. Click the  button next to the **Additional command** field.
5. Select the command in the **Select command** dialog. Click **OK**.

The  button clears the field.

## Toolbars Display Settings



Ribbon: **Manage – Customization – Interface** >  **Toolbars**



Menu: View > **Toolbars – Toolbars Settings...**



Menu: Format > **Interface – Toolbars Settings...**



Command line: **TOOLBARS**

Sets the display of toolbars on the screen.

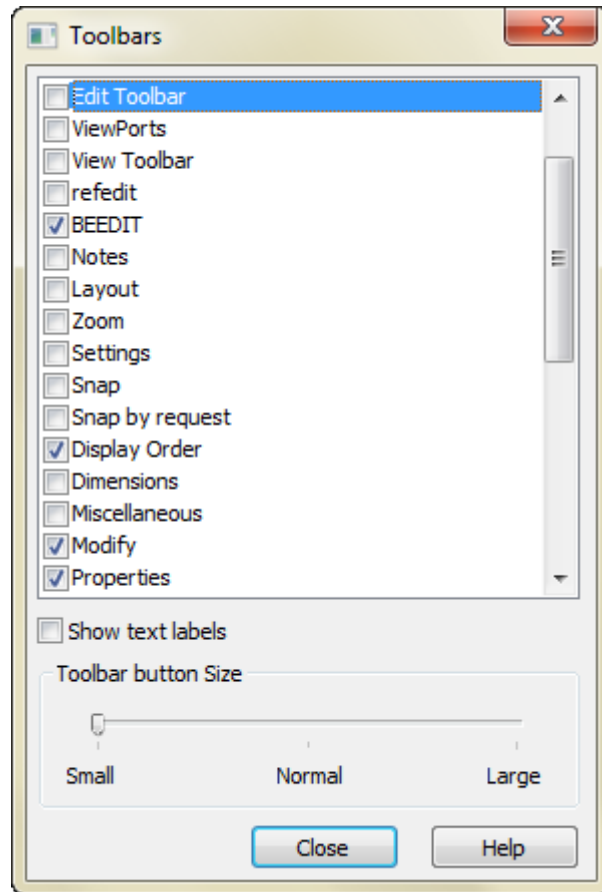

**Options:**

**Show text labels**

Turns on/off text prompt on buttons.

**Toolbar button Size**

Sets the size of all toolbars:

**Small**

**Normal**

**Large**

## Accelerators Tab

**Accelerators** tab allows you to add *keyboard shortcuts (hot keys)* combinations for often used commands

*Keyboard shortcut* – is a combination of symbol key and control keys **CTRL**, **SHIFT**, **ALT**, For example, press **CTRL+O** to open a file, ; **CTRL+S** – to save the document, etc.

Combinations of hotkeys used in nanoCAD are displayed on the right side of context and drop-down menus, as well as in toolbar button tooltips.

It is possible to set several keyboard shortcuts for one command.

**Accelerators** tab contains existing shortcuts.

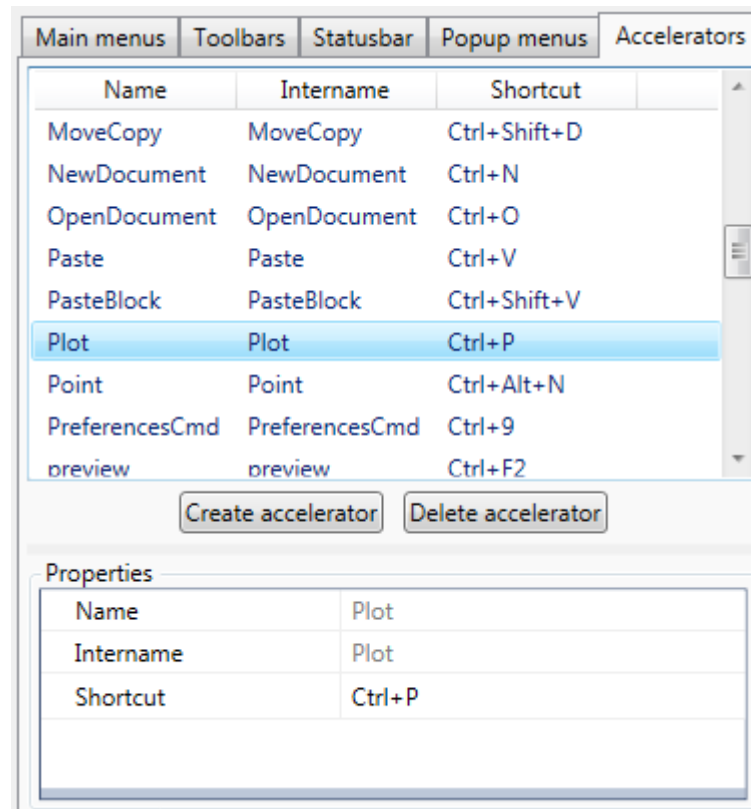

### To create a shortcut

1. Click **Create accelerator** button.
2. Press the desired combination on a keyboard.

If combination is already used, the field is highlighted.

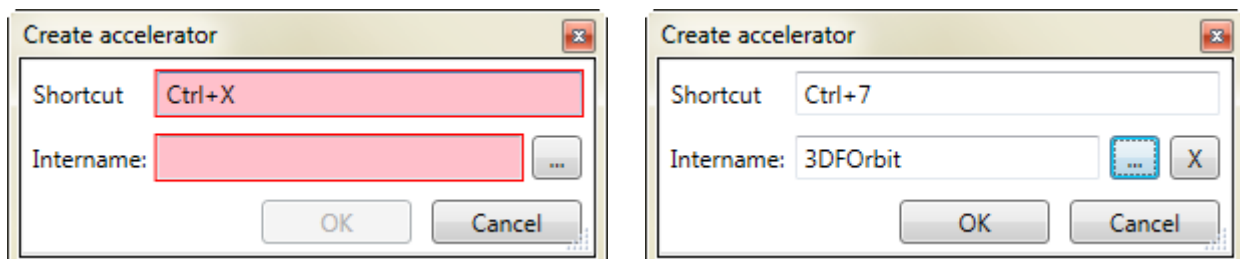

3. Press the button  near **Intername** field.
4. Select the desired command in a **Select command** dialog box. Click **OK**.
5. In the **Create accelerator** dialog, place the cursor in the **Shortcut** field and press the desired combination on the keyboard.

You can also assign a shortcut to a command by selecting it in the list of tools in the right window and dragging it to the list of commands on the left. The **Create accelerator** dialog will immediately display the **Intername** of the selected command. You just need to assign a combination in the **Shortcut** field.

If the assigned keyboard shortcut matches an existing one, a warning is displayed in which you can reassign the existing shortcut to another command.

### Import shortcuts

1. Select the **Import shortcuts** command in the menu of the **File** button of the **Customize user interface** button.
2. In the **Open** dialog, select configuration files with \*.cfg or \*.cuix extension.
3. In the **Import shortcuts** dialog, check the combinations to import, click **OK**.

**NOTE** If the current file is the master file, then the combinations are added to ncadbase.cfg.

If the included file is the current one, the combinations are written to it. If there is a conflict between identical combinations (when a combination that already exists in ncadbase.cfg is written into the included one), the command that is higher in the list is executed.

If you attach a file with combinations using the **Load partial file** command, the combinations are processed. If there is a conflict between identical combinations, the command specified in ncadbase.cfg is executed.

However, it is recommended that you use the **Import Shortcuts** command to load shortcuts.

### Additional accelerator for command

1. Select the command in the list of shortcuts.
2. Call the **Find tool** context menu.
3. Select command in the list and call **Create accelerator** context menu.
4. Press the desired combination on a keyboard, then click **OK**

### Change accelerator

1. Select command in the list of shortcuts.
2. Set new combination in **Properties**.

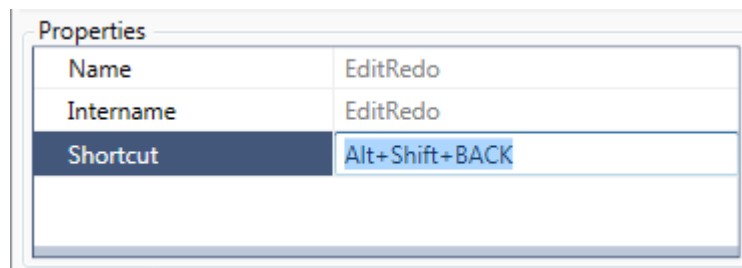

### Remove keyboard shortcut

1. Select command in the shortcut list.
2. Click **Delete accelerator** button.

You can also delete the selected combination using the **DEL** key.

## Object Actions Tab

The **Object Actions** tab of the [Customize user interface](#) dialog assign the commands and actions to be performed when using mouse buttons for the object selected on the screen:

- **Double-click on single object**
- **Double-click on multiple objects**
- **Context menu on single object**
- **Context menu on multiple objects**

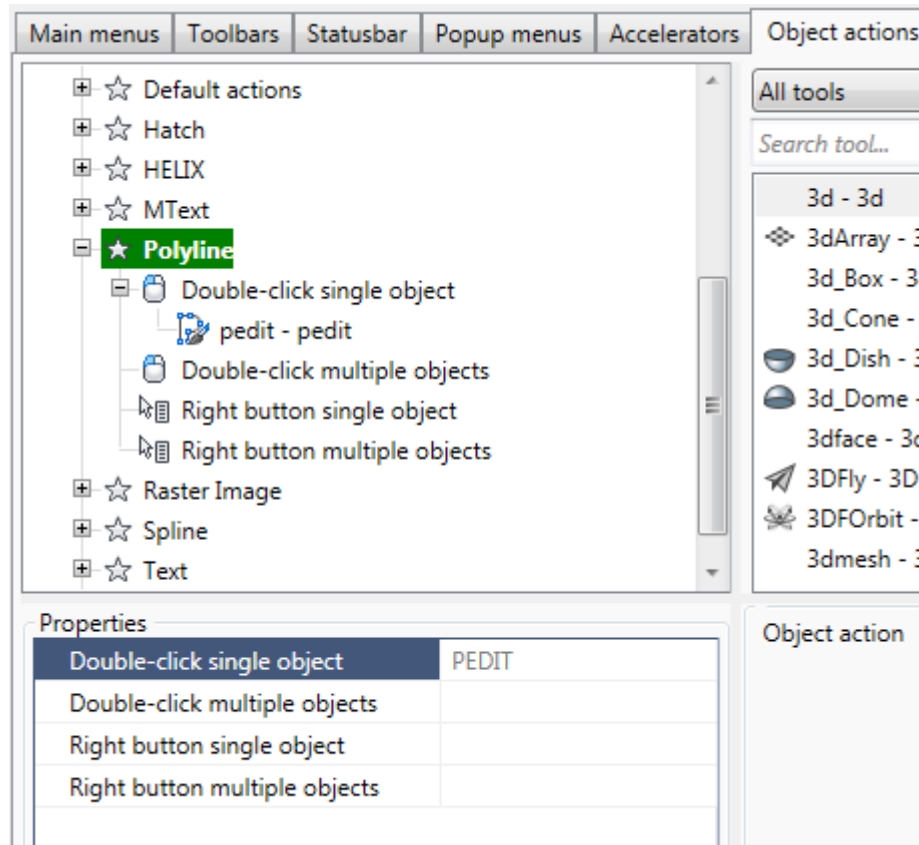

To add a command for double-clicking with the left mouse button on one or more objects, drag the command from the list of tools on the right to the desired action.

To add a context menu for single or multiple selection, select **Add new menu** or **Add existing menu** from the context menu of the desired action:

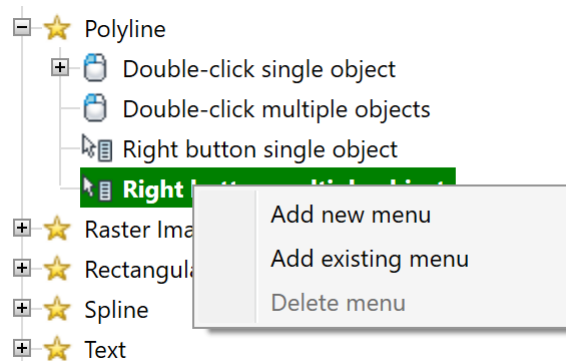

## Status Bar Tab

**Status bar** tab manages elements in the status bar of nanoCAD.

It is possible to add button, control, property, separator to the status bar. Add element by drag and drop from the list of tools. Set the element parameters in **Properties**.

### Add control

1. Select **Insert control** in the context menu.
2. Set parameters in **Create status bar control** dialog box.



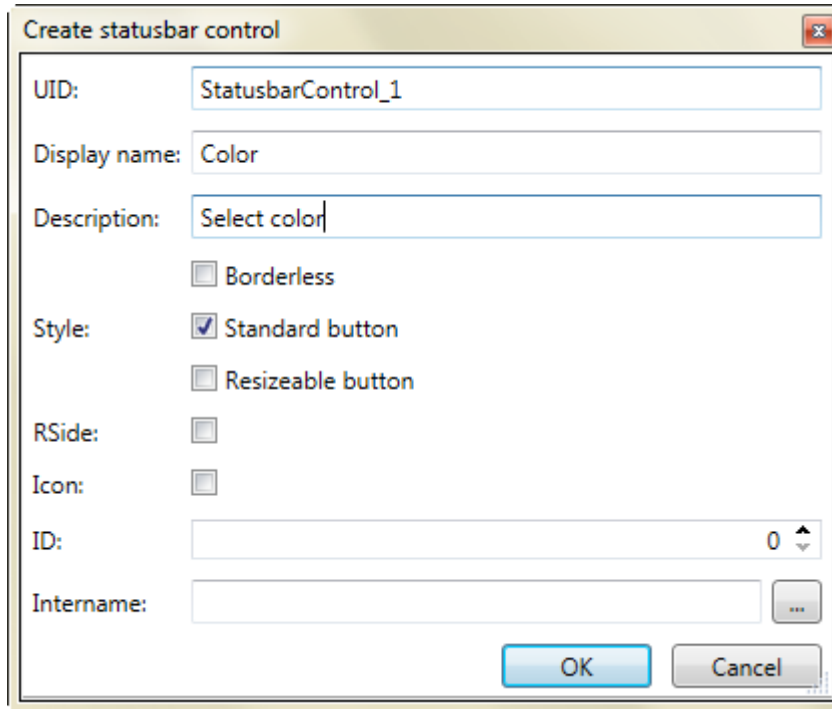

### Add button

1. Select **Insert item** in the context menu.

Set parameters in **Create status bar item** dialog box. Item parameters are identical to **Create status bar control** dialog box.

### Add property

1. Select **Insert property** in the context menu.
2. Set parameters in **Create status bar property** dialog box.

The following parameters are added to the previous ones: **Width, Fixed width.**

### Remove status bar elements

1. Select the desired element.
2. Use **Delete** command in context menu.

## Rollover Tooltips Tab

Set properties to be displayed when cursor pointing to the object.

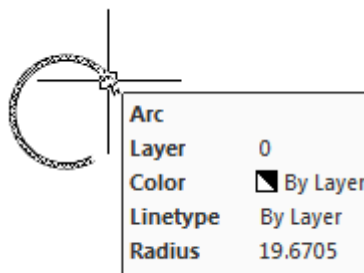

Object list is at the left part of tab.

Right part of tab displays properties to select.

The properties are enabled by clicking the checkbox. The **Select All** option includes all object properties in the tooltip.

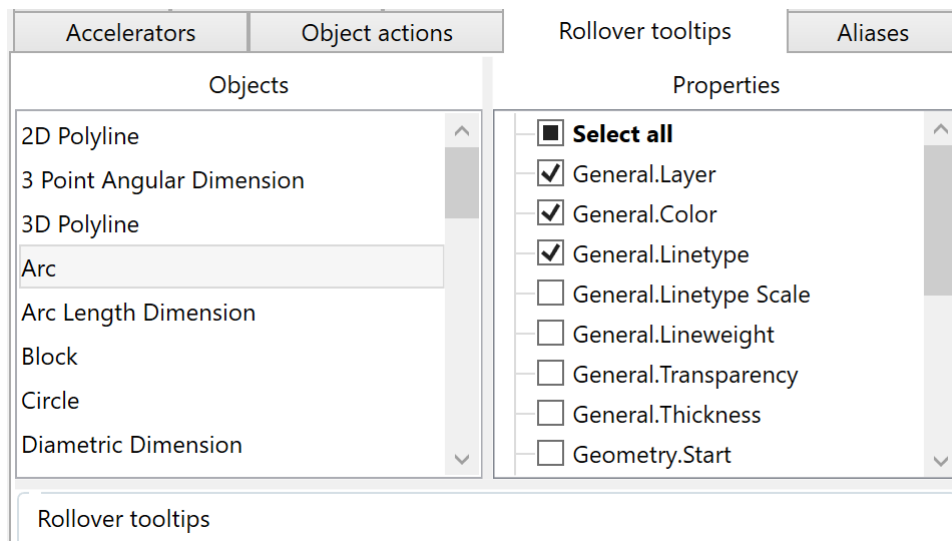

## *Aliases Tab*

Aliases tab sets alternate names (aliases and abbreviations) for commands to call them from command line.

One command can have several aliases. Each alias belongs to only one command.

The left part contains a list of commands with assigned aliases.

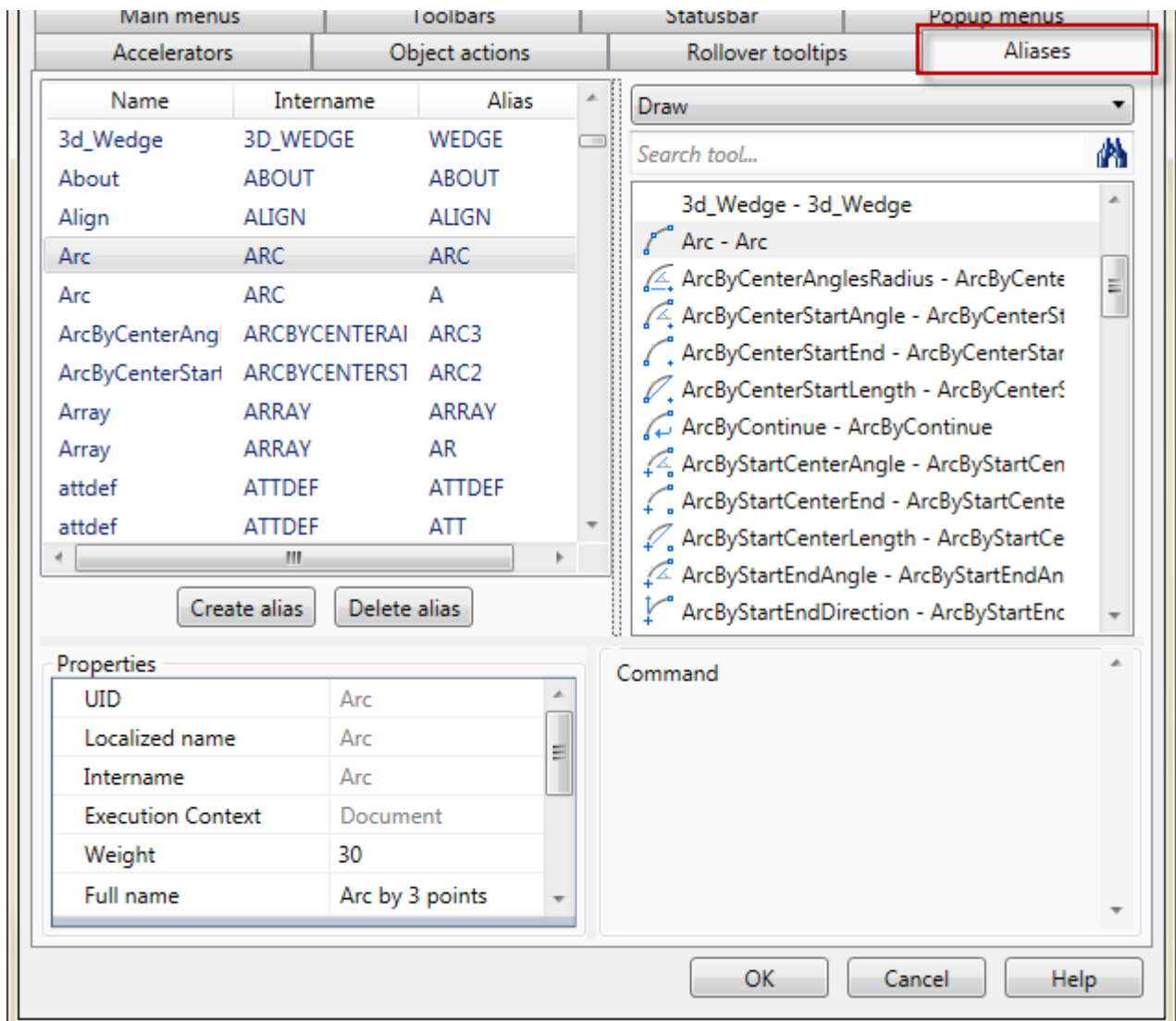

### Create an alias

1. Click the **Create alias** button.
2. Click the  button in Create alias dialog box, select the command from the list.
3. Type symbols into **Alias** field.

Or

1. Select command at the list.
2. Call **Create alias** in context menu.
3. Type symbols into **Alias** field.

Manage aliases in the **Properties** section:

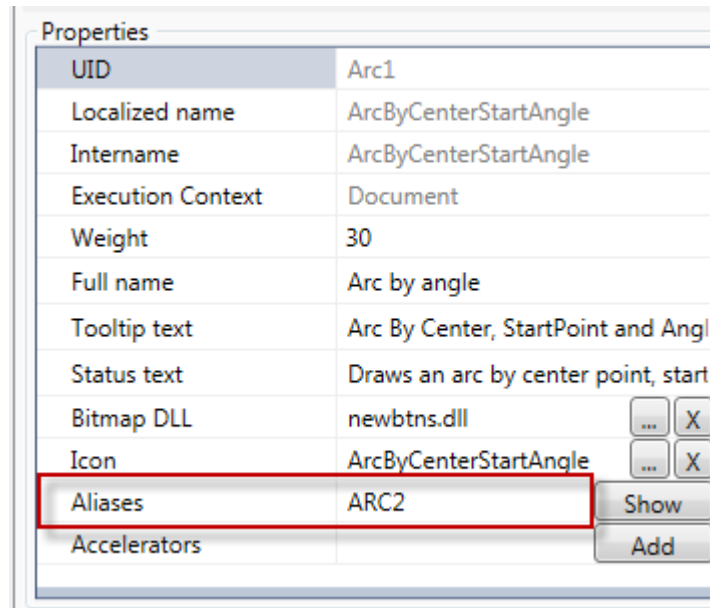

The **Show** button highlights a command in the list of commands in the left window with aliases.

### Change alias

1. Select command with alias from the left list in the tab.
2. Type new **Alias** into **Properties:**

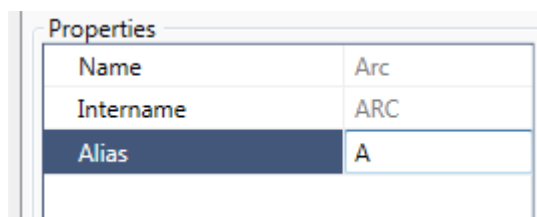

### Remove alias

1. Select command with alias from the left list in the tab.
2. Click **Delete alias** button.

You can also delete the selected combination using the **DEL** key.

## Create New Command

Add custom command to the nanoCAD interface.

Custom command should be loaded with **Tools – Application > Load application...** and should be automatically loaded for each new nanoCAD session

1. Call **Create command** context menu in the command list.
2. Set command parameters in a **Create command** dialog box.

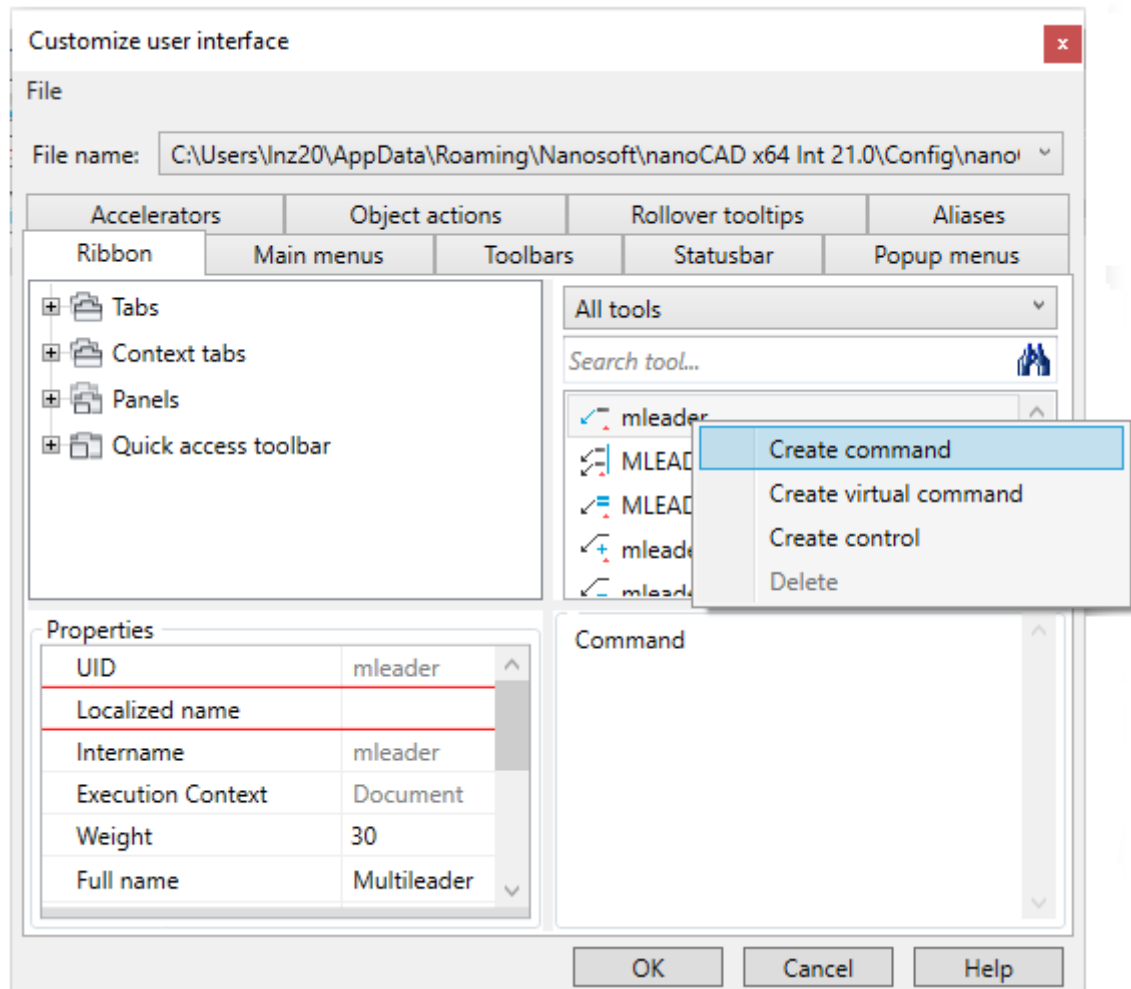

3. Set new command parameters in the **Create command** dialog box. The highlighted fields are mandator for filling.

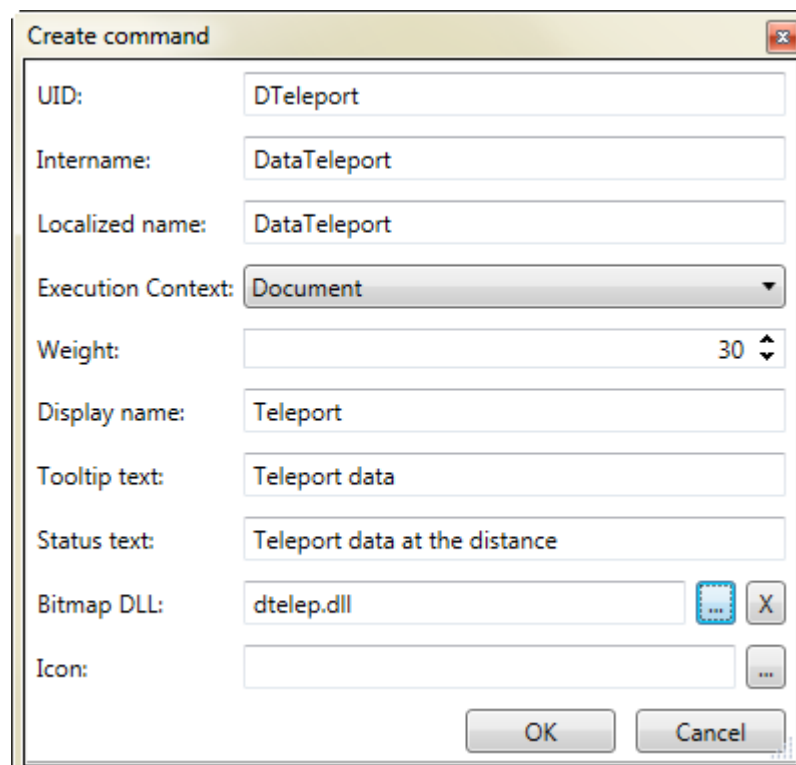

### Command parameters:

<b>UID</b>	Element identifier.
<b>Intername</b>	The name of loaded command. It can contain the following symbols: <b>A-Z, 0-9, ), (, _, #, \$</b> . No spaces. Intername often fits with <b>UID</b> .
<b>Localized name</b>	Localized name of command. It can contain national characters and the following symbols: <b>A-Z, 0-9, ), (, _, #, \$</b> . No spaces.
<b>Execution context</b>	Select Document if the command should work on opened document. Select Application to use command when no opened document.
<b>Weight</b>	Priority of command when several commands run at once. Lowest weight has the highest priority
<b>Full name</b>	Full name of the command. Often coincides with the Display name.
<b>Display name</b>	The name of command, displayed in menu.
<b>Tooltip text</b>	Displayed when cursor pointing to the object.
<b>Status text</b>	Text in the command line.
<b>Bitmap DLL</b>	DLL-file containing the command.
<b>Icon</b>	Icon of command, displayed on toolbars and menus.

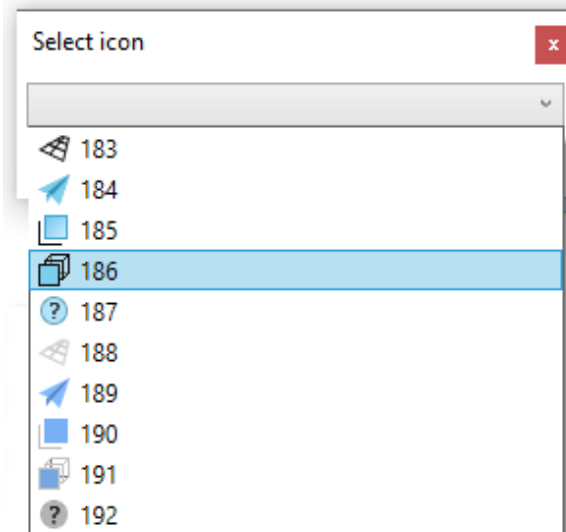

The command appears in the list of tools in the right part of the **Customize user interface** dialog. It can be placed in the menu, toolbar or command line.

## Create Virtual Command

*Virtual command* is real command with selected values and keywords. Used to create similar objects.

A virtual team is created based on an existing one. It is designed to call a regular command and pass it values stored as a virtual command parameter.

See an example: how to create circle with specified insertion point and diameter.

1. Select **Create virtual command** in the context menu on the command list.

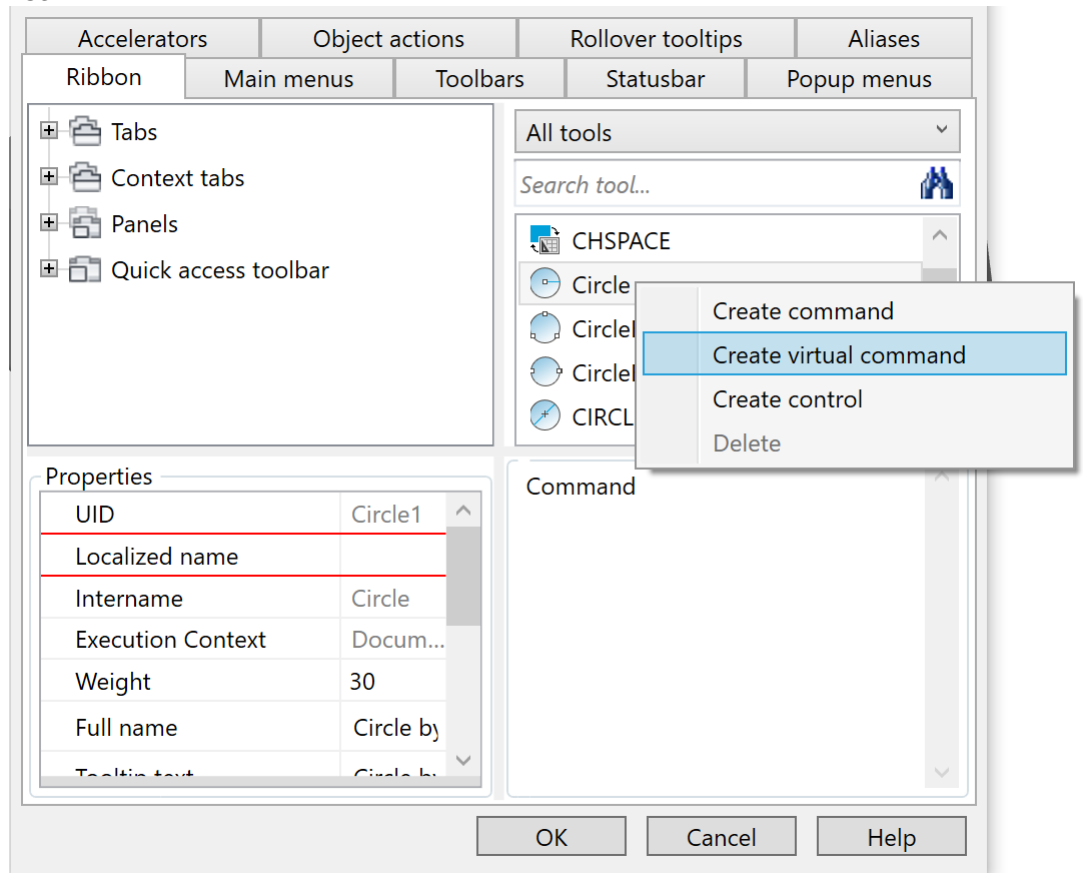

2. Set parameters of new command in **Create virtual command** dialog box.

Create virtual command

File: nCadBase.cfg

Intername:

Localized name:

Execution Context: Application

Weight: 0

Display name:

Tooltip text:

Status text:

Bitmap DLL:  ...

Icon:  ...

Real command name:  Command line parameters  
 Command parameters

Circle  ... X

Keyword:

OK Cancel

### Command parameters

- File** nanoCAD configuration file in which this command is written (registered).
- Intername** The name of loaded command.  
 It can contain the following symbols: **A-Z, 0-9, ), (, \_, #, \$**. No spaces.  
 For example: `circle300`
- Localized name** Localized name of command.  
 It can contain national characters and the following symbols: **A-Z, 0-9, ), (, \_, #, \$**. No spaces.  
 For example: `circle300`
- Display name** The name of command, displayed in menu.  
 For example: `circle300`



## Real command

Base command for virtual command.

There are two types of command call:

- **Command parameters.** Specify the command in **Real command name** field and then type its keywords in **Keyword** field
- **Command line parameters.** Inserts all the text from **Keyword** field to the command line.

Command line parameters  
 Command parameters

Real command name:  ...

Keyword:

For example, select **Command parameters** and then find **Circle** command in the list.

## Keyword

Value of command parameters. Type values in order of command line request through the space.

For example, type the following parameters: *insertion point space radius*.

10,10 300

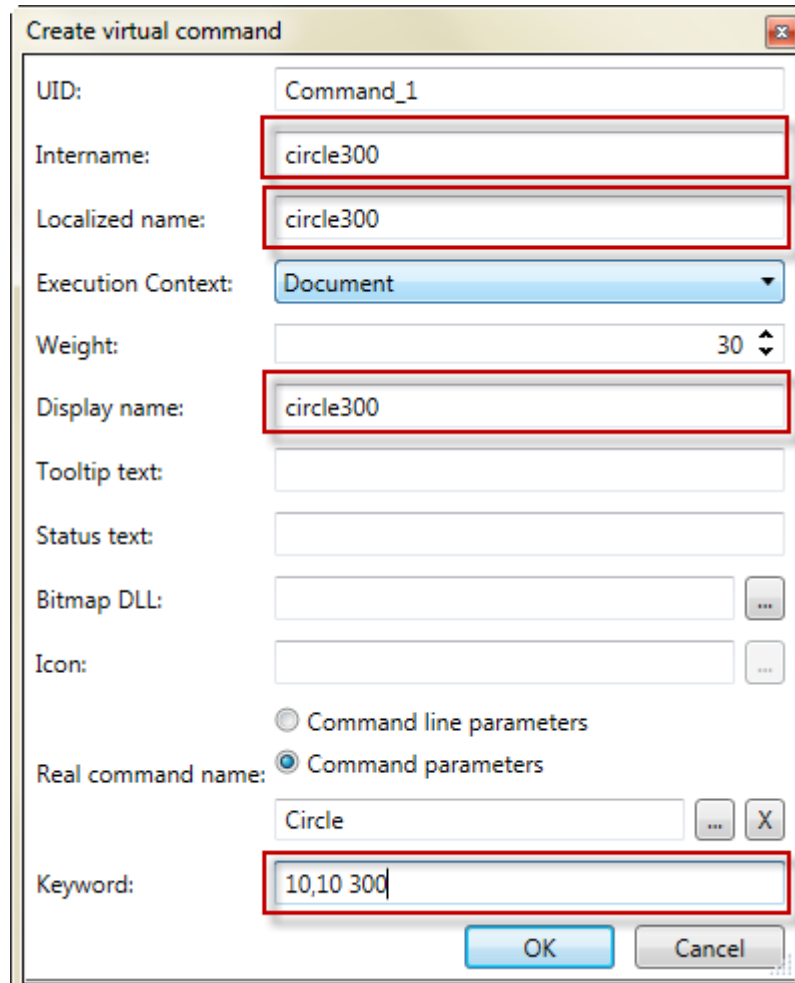

Create virtual command

UID:

Intername:

Localized name:

Execution Context:

Weight:

Display name:

Tooltip text:

Status text:

Bitmap DLL:  ...

Icon:  ...

Command line parameters  
 Command parameters



Real command name:  ... X

Keyword:

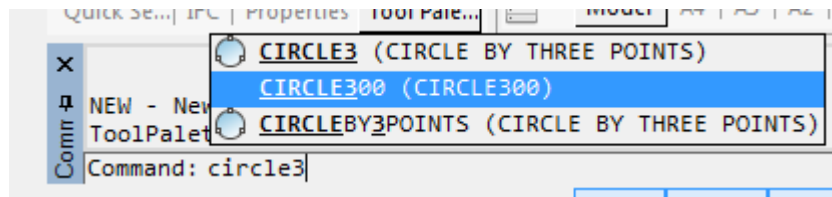
When you call circle300 command, new circle will be created in specified point with specified diameter.



## Design Settings

-  Ribbon: **Manage – Customization > Design Settings**
-  Menu: **Tools – Settings Parameters...**
-  Command line: **PARAMS**

Interface and parameters of annotations are set in the **Settings** dialog box in nanoCAD:

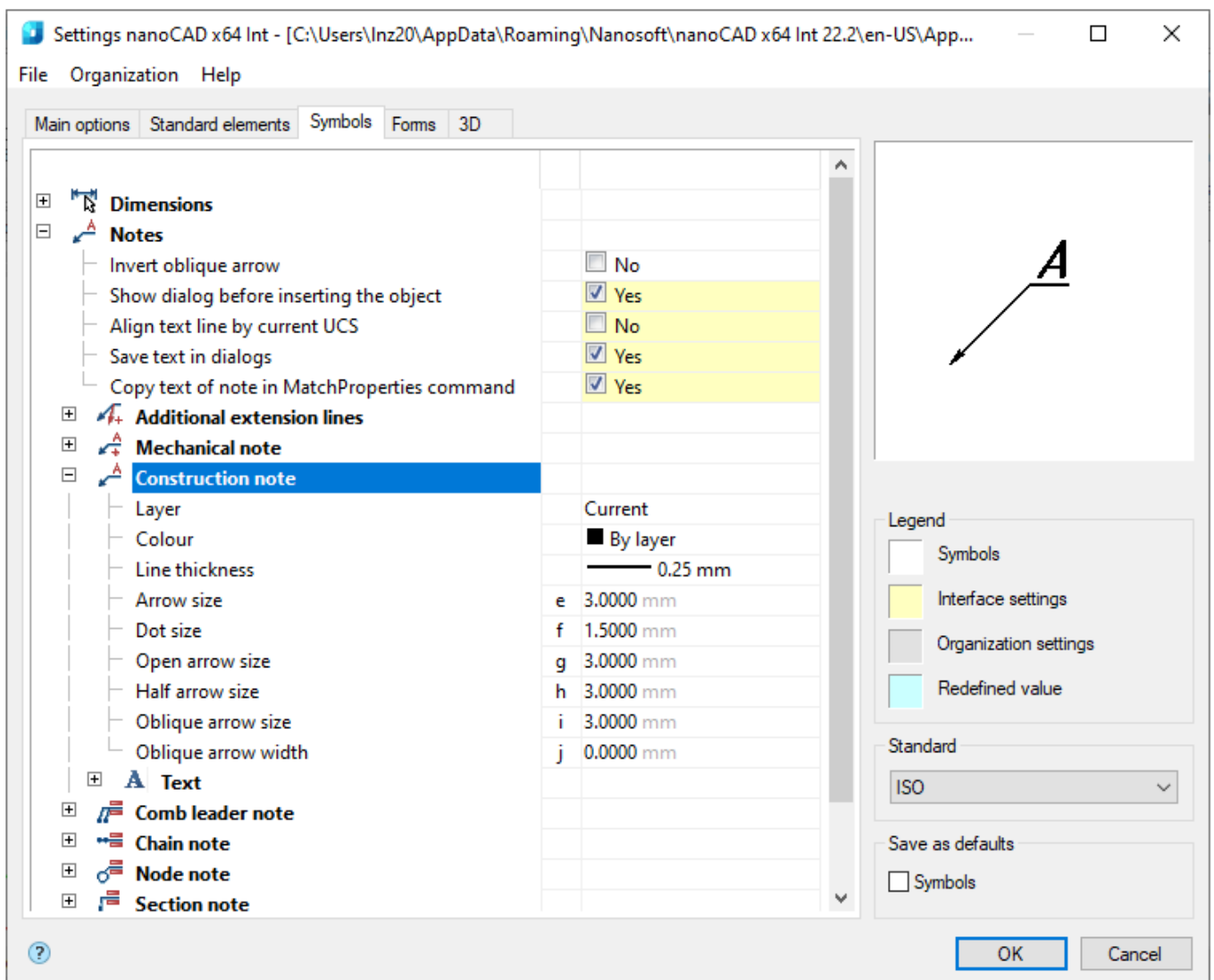

The path to the settings file is shown in the top part of the dialog box.

The **Open** button opens a standard dialog box for the selection and loading of a new settings file.

The main window of the dialog contains the following tabs: **Main, Standard elements, Symbols, Forms.**

The parameters of the settings are shown in a tree form.

There is a graphic illustration of the adjusted parameters in the right part of the dialog box:

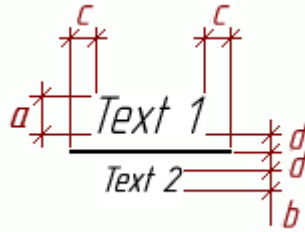

Select a parameter from the drop-down list:

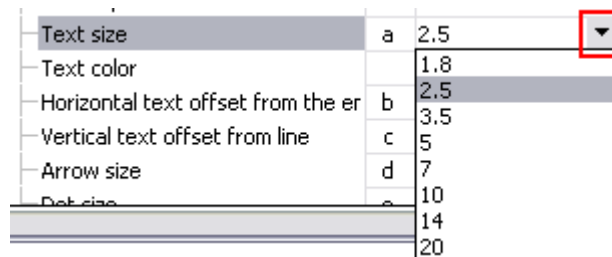

or in the dialog box by pressing the  button:



The values of some parameters are entered from the keyboard:



The drop-down list in the **Standard** section is used to change the standard:

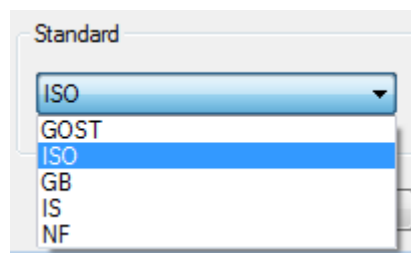

It is strongly recommended to match a \*.dwt working template with nanoCAD settings.

What can be unified:

- Dimension and text styles. It is recommended to adjust nanoCAD according to \*.dwt template settings.
- The global scale of linetypes.
- Layers names and properties. By default, many nanoCAD objects use a "current" layer for insertion. It is recommended to set layers' names from a \*.dwt template.
- Layouts names and their settings.
- Plot styles of objects, if a \*.dwt template with named plot styles is used.

The **Legend** area illustrates the use of background colors in parameters.

The **Save as defaults** contains the **Symbols** checkbox; when it is checked the design settings will be saved by default.

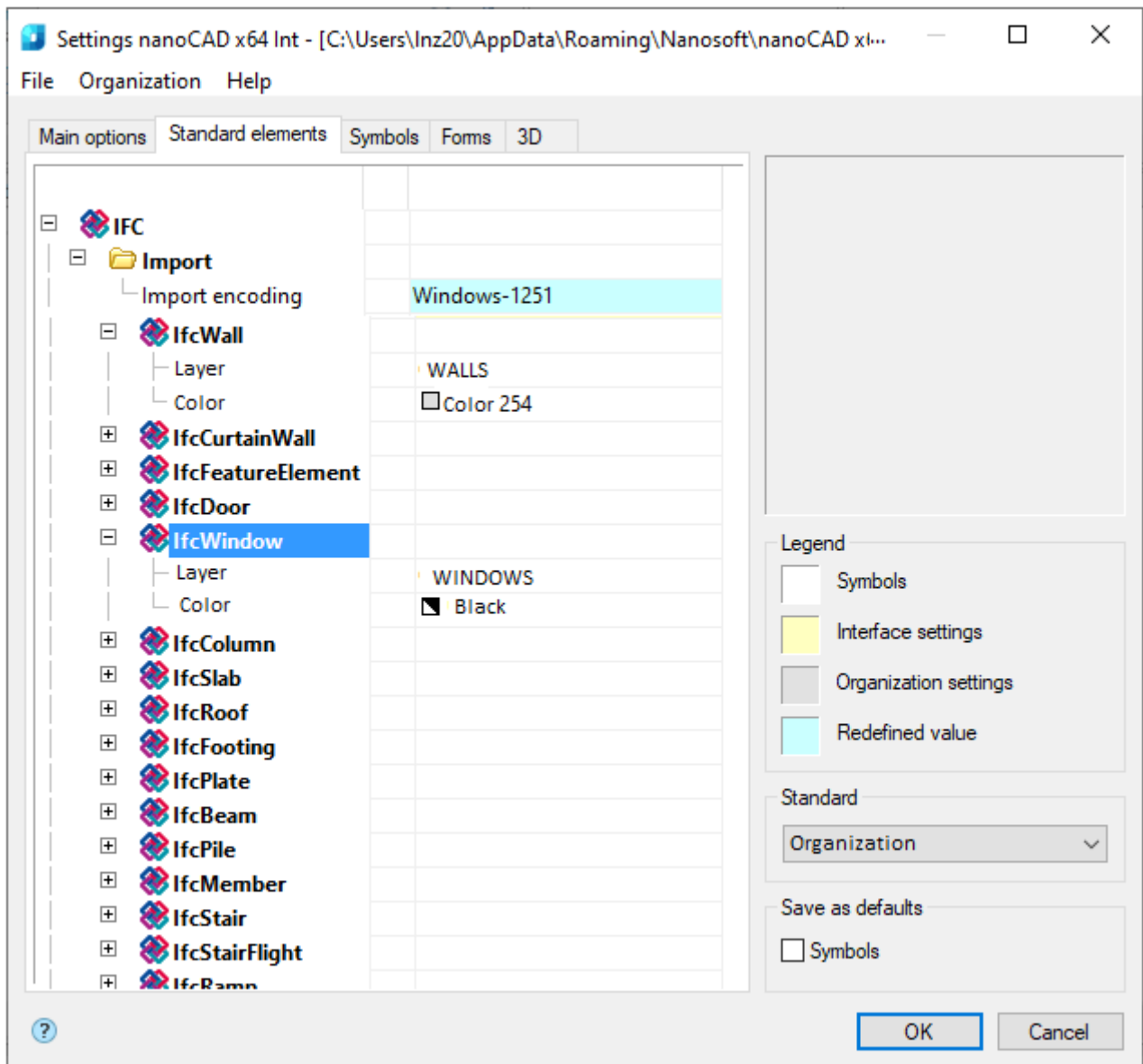

## Main Menus

### File menu

#### Save settings

Saves changes to the current settings file.

#### Save settings as ...

Saves changes to a new settings file.

#### Load settings

Loads settings from another file. Acceptable file types:

- Configuration files (\*.xml)
- Settings for design elements (\*.cfg)
- Interface settings (\*.icf)

The settings files \*.cfg and \*.icf were used in previous versions of nanoCAD and contain settings that in this version are stored in AppOptions.xml.

#### Restore start settings

Loads the settings preset in nanoCAD.

**ATTENTION!** If the name of the file being saved coincides with the name of an existing file, the function of saving settings **does not overwrite** the old file, but **supplements** it. Therefore, when the standard is changed, for example, from ESKD to ISO, both standards will be available in the settings file.

### Organization menu

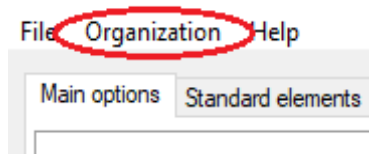

The **Organization** menu controls the settings of organization standards.

*Organization standard* is a single file of settings (parameters, layers, profiles) for the enterprise. All settings are stored in one file.

In the settings dialog, in the table of profiles and layers, the Organization settings are highlighted in light gray.

The **Organization** menu includes the following items:

### Create network settings

Creates a file of corporate settings to transfer to other machines or place on the common server. Steps to create a settings file:

1. After running the command, a selection field will appear next to each parameter and section.

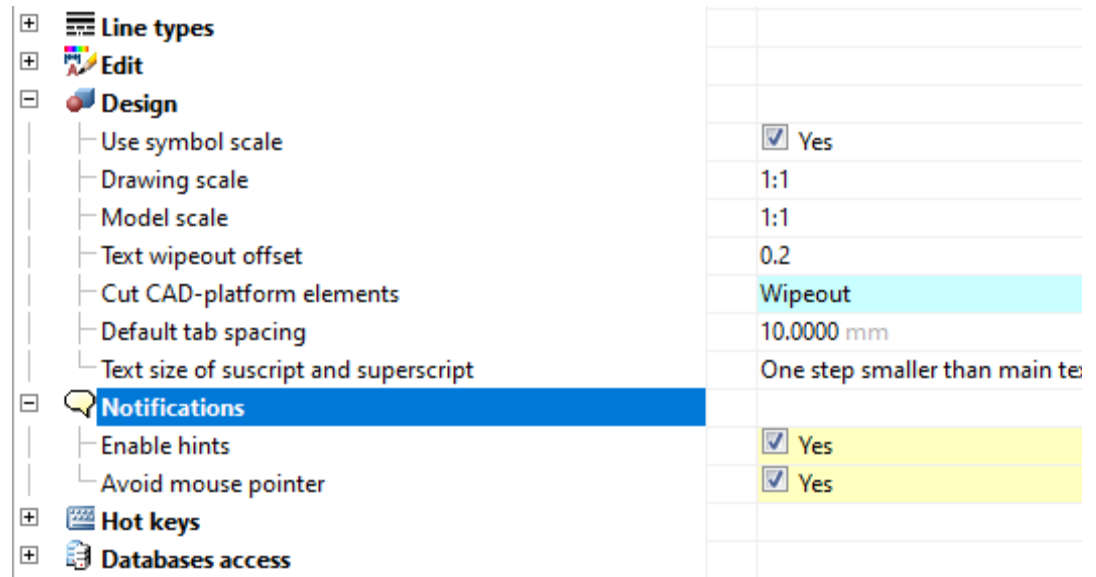

2. Check the box to the left of those settings that will fall into the Organization. Click the **OK** button.

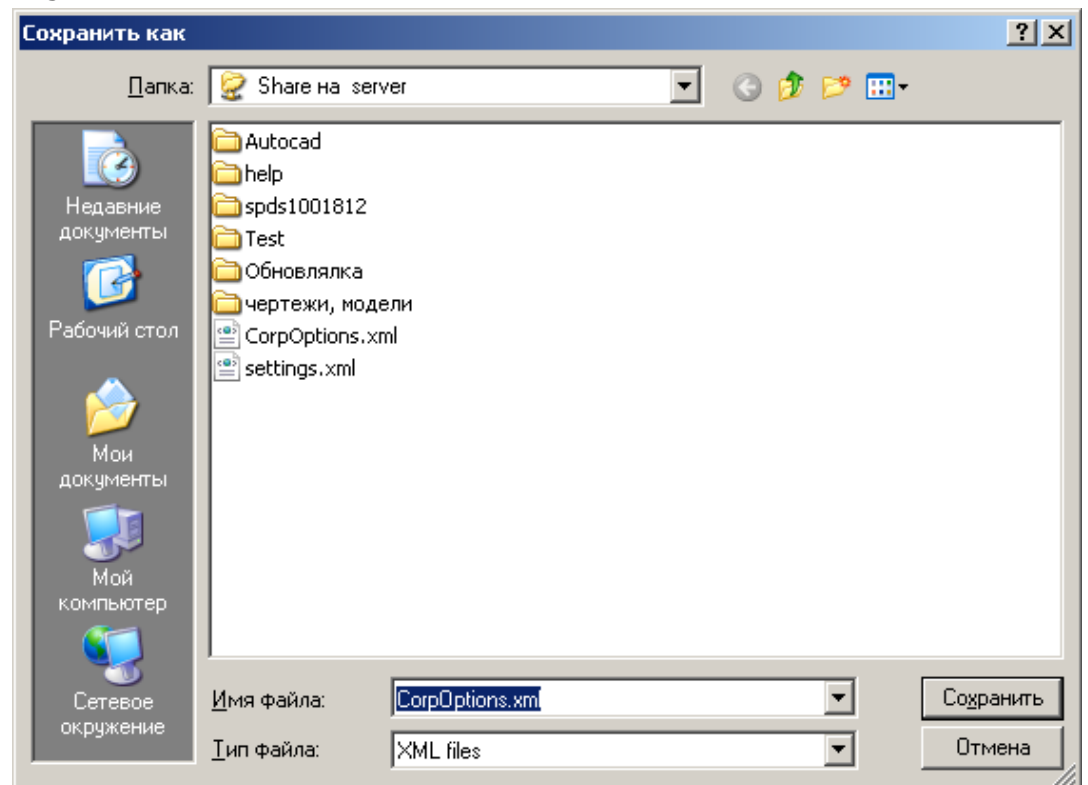

3. Provide a location and file name to save organization settings. The organization settings file will be created.

### Set settings file ...

Assigns a settings file, which will get preference over the current AppOptions.xml custom settings file. New documents will be created according to the values from the assigned file.

### Flush

Refusal to use the organization settings. In this case, the custom settings file AppOptions.xml becomes the control file.

### Apply organization settings to document

Applying organization settings to documents created without using these settings.

**ATTENTION!** The user cannot delete the Organization layers and profiles from the corresponding tables in the settings dialog.

When saving settings with new values, they will be applied only to the current document.

The configuration of settings in the Organization file and standards within the configuration should strictly correspond to the loaded settings in the application. If there is a mismatch, the settings override will not work!

## Main Options Tab

The tab is intended to set the nanoCAD main parameters.

### Common settings

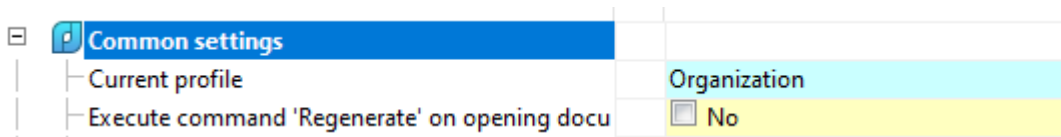

### Current profile

Layer profiles are designed to organize the work of various departments of the enterprise on one drawing file. At the same time, each user works with his own group of layers, controlling their visibility by means of nanoCAD.

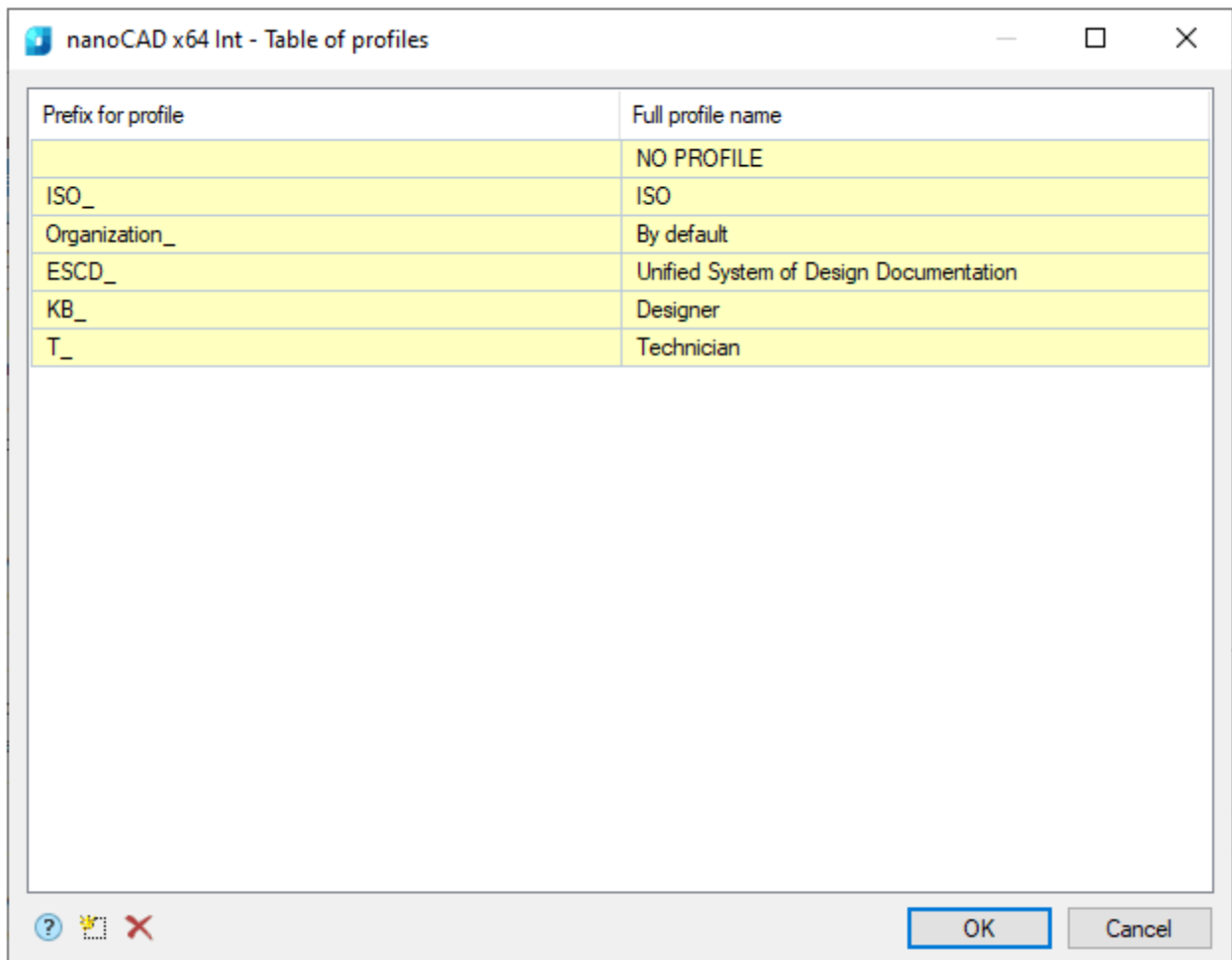

Since the drawing design depends on the settings for the placement of design elements by layers and the current profile of the drawing, then for each type of object you need to set the option of placement on the corresponding layer in the settings (for example, for leaders, the *Leaders* layer is set).

Depending on the current profile, a prefix will be added to the layer name.

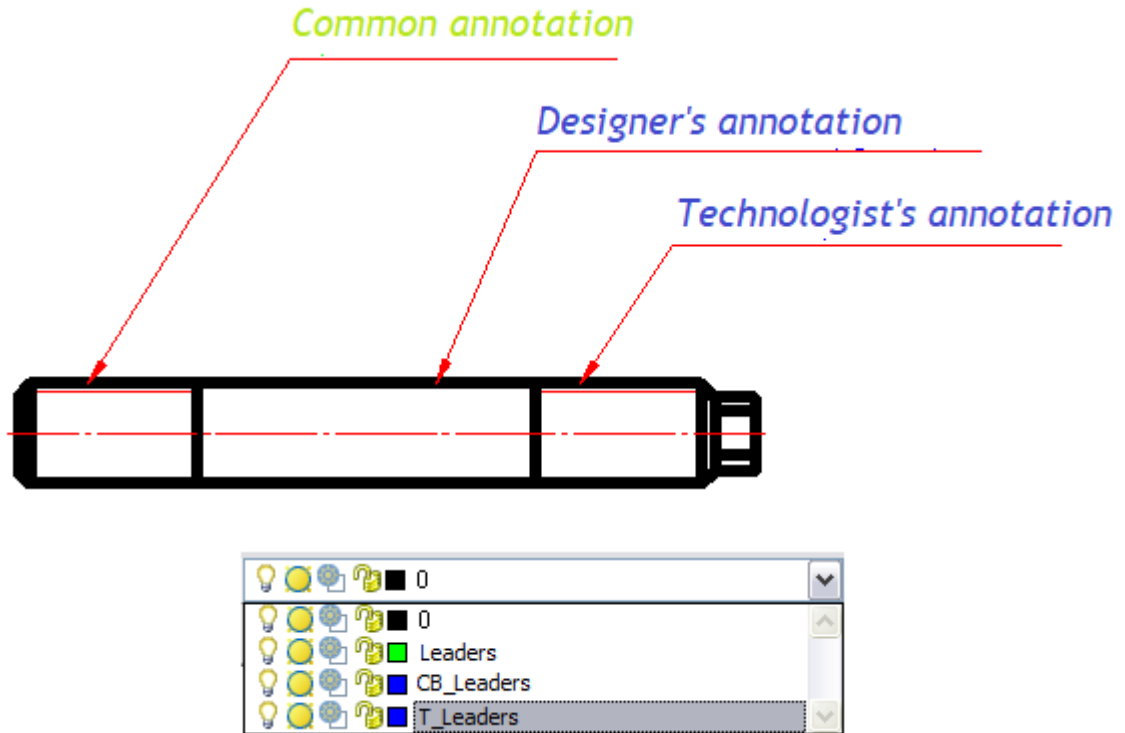

Thus, you can group layers created by users with the same profiles (for example, layers of objects built by designers - by the "KB" prefix, and by technologists - by the "T" prefix).

*Perform the Refresh command when opening a document*

The Refresh command is performed at each opening of a document (see Refresh command).

*Save proxy-objects with graphics*

Enables or disables saving proxy objects with graphics.

**Line types**

Standard nanoCAD objects are displayed with line types provided by GOST 2.302. Line thickness and color parameters are included in the general settings section of the Linetypes group.



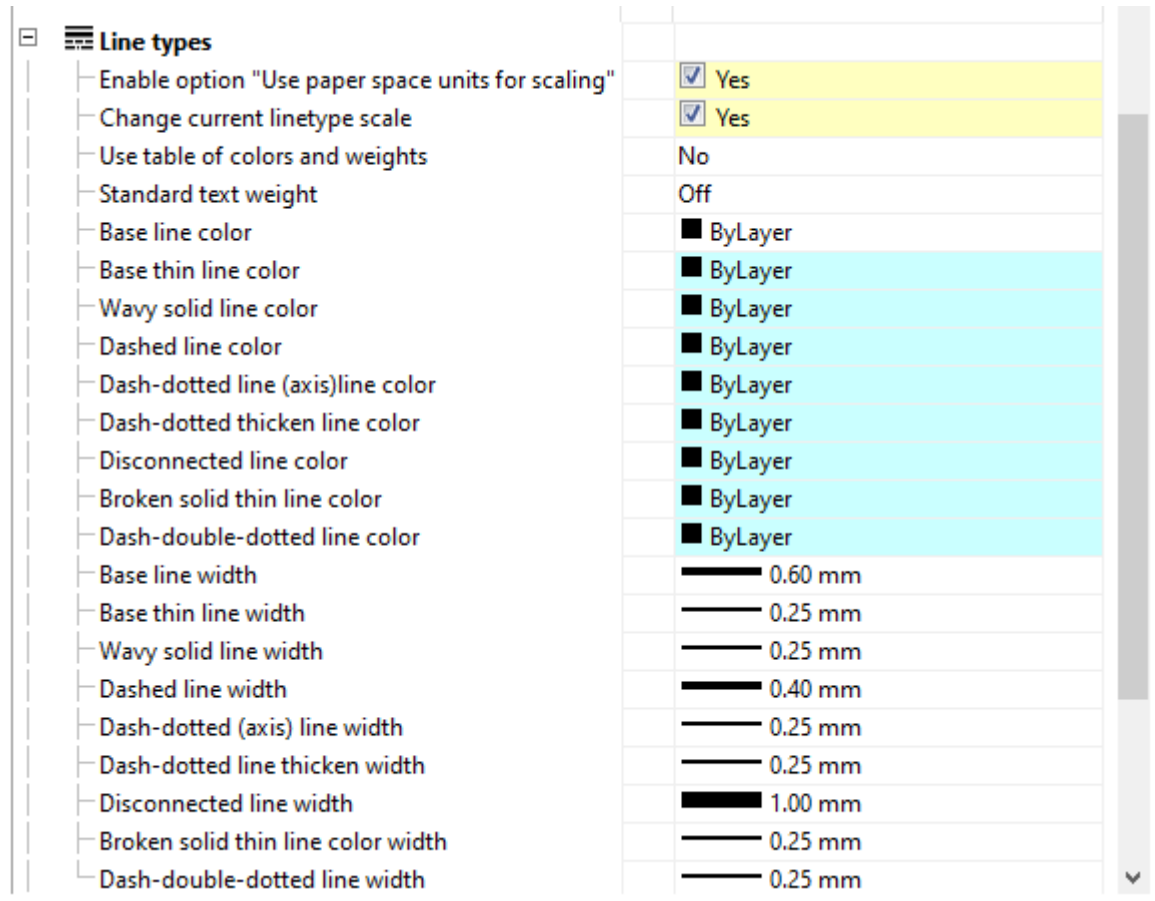

*Automatically disable the "Use paper space units for scaling" option*

Automatically changes the nanoCAD setting "Use paper space units for scaling" for linetypes.

*Change current linetype scale*

Enables or disables the scaling of linetypes in standard objects when their scale is changed. When the setting is enabled, inserted design elements and database objects are automatically scaled in accordance with the scale of the **Scale** toolbar.

*Use table of colors and weights*

Enables or disables the use of color and weights table. If the setting is enabled, you can use standard colors from the table. The **Compatibility mode** value is used when working with documents created in earlier versions of nanoCAD.



*Standard text weight*

Standardizes the amount of text weight for all texts in a document.

*Line color and width*

This group of settings assigns the design option for certain types of lines.

## Edit

 Edit	
Decimal delimiter correction	Use dot '.' as decimal delimeter
Create and activate standard text and dimension	<input checked="" type="checkbox"/> Yes
Explode Block References under drawing desing e	<input type="checkbox"/> No
Enable enhanced grips	<input checked="" type="checkbox"/> Yes
Set associativity during insertion of objects	<input checked="" type="checkbox"/> Yes
Use localized abbreviations of command keyword	<input checked="" type="checkbox"/> Yes
Highlight color	<input checked="" type="checkbox"/> Green
Automatically switch keyboard layout to local lan	<input type="checkbox"/> No
Show rectangle around objects	<input type="checkbox"/> No
Automatically turn on snaps: Nearest, Endpoint, C	<input checked="" type="checkbox"/> Yes
To show the toolbar "Direction" automatically	<input type="checkbox"/> No
Scale dimensions	<input checked="" type="checkbox"/> Yes
Scale texts	<input checked="" type="checkbox"/> Yes
Scale hatches	<input checked="" type="checkbox"/> Yes
Scale .dwg tables	<input type="checkbox"/> No
Ignored layers	
Unplotted layer	UNPLOTED
Mini-toolbar for viewports	<input checked="" type="checkbox"/> Yes
 By double-click	
 Design	

### Decimal delimiter correction

Controls the way to automatically replace the decimal delimiter character:

- **Do not correct decimal delimiter.**
- **Use dot "." As decimal delimiter** – an option for programs that accept only a dot.
- **Use system locate decimal delimiter** – decimal delimiter from OS localization settings is used.

### Create and activate standard text and dimension styles in new documents and when changing standards

Controls the creation of standard styles. The default is **Yes**. Setting this parameter to **No** allows you to create new documents without predefined standard styles.

### Explode Block References under drawing design elements

- **Yes** – to overlap nanoCAD by objects, nanoCAD blocks are split.
- **No** – to overlap nanoCAD by objects, nanoCAD blocks are masked (**wipeout**).

### Enable enhanced grips

When this function is enabled, additional nanoCAD grips are displayed on the objects, for example: "Flip", "Insert leader line", etc.

### Set associativity during insertion of objects

The setting is enabled by default. When it is disabled, the snap of inserted objects to primitives is not active.

### Use localized abbreviations of command keywords

Allows or denies the use of abbreviations for the command keywords described in the file with the .pgp extension and located in the nanoCAD installation folder.

### Highlight color

The highlight color for primitives when it is required to specify them. For example, line highlighting when specifying for dimensioning.

### *Automatically switch keyboard layout to local language*

When you call dialogs with fields in nanoCAD, the local layout is automatically turned on.

### *Show rectangle around objects*

Controls the display of the bounding box around objects and nanoCAD blocks. When this option is enabled, scaling is disabled by **SHIFT**+**RMB**.

### *Automatically turn on snaps: Nearest, Endpoint, Quadrant, Center, Intersection*

Temporary turns on the listed snaps when some nanoCAD command work.

- If the option is disabled, some dimensioning modes will not work.
- If the option is disabled, the **Direction** toolbar will not work correctly.
- If the option is disabled, placement along the leader line, slope symbols, symbols of base and, possibly, other objects will not work.

### *To show the toolbar "Direction" automatically*

Controls display of the **Direction** toolbar, which appears when inserting database objects and in a number of other commands.

### *Scale dimensions*

Yes value. The global scale set in the Dimension Styles on the Fit tab is replaced by the design scale.

No value. The global scale is not changed.

**NOTE:** If the design scale differs from the global scale value, then a dimension style override will be created.

### *Scale texts*

Applicable for the inserted text.

Yes value. When you change the design scale using the Scale toolbar, the Height parameter changes proportionally in the Text Format dialog for multiline text and in the command line for single line text.

No value. When you change the design scale using the Scale toolbar, the Height parameter does not change.

The platform saves the value of the last entered text height. When this option is enabled, changing the design scale proportionally changes the saved height value. The new text will have the modified height.

*Example: Initial data – text height 10, scale 1:1. Change the scale to 1:15. The height of the new text will be 150.*

### *Scale hatches*

Applicable for the new hatches.

**Yes** value. When you change the design scale using the **Scale** toolbar, the **Scale** parameter in the **Hatch** changes proportionally.

**No** value. When you change the design scale using the **Scale** toolbar, the **Scale** parameter in the **Hatch** dialog does not change.

The platform saves the value of the last entered hatch height. When this option is enabled, changing the design scale proportionally changes the saved height value. The new hatch will have the modified height.

*Example: Initial data – hatch height 10, scale 1:1. Change the scale to 1:15. The height of the new hatch will be 150.*

### Scale .dwg tables

The setting is used when creating a dwg table. If the setting is disabled, the table is inserted with the dimensions specified in the table creation dialog. If the setting is enabled, the size of the inserted table changes in proportion to the design scale.

### Ignored layers

Specifies nanoCAD layers for which primitives located on them will not be overlapped by nanoCAD objects.

### Unplotted layer

Specifies the layer on which nanoCAD objects excluded from plot (group markers, non-printable markers, mark anchors, shown dependencies) are placed.

### Mini-toolbar for viewports

Controls the display of special nanoCAD mini-toolbar  by the right click inside the viewport in a layout.

If the option is disabled, then the right click inside a viewport will call the standard nanoCAD context menu.

### By double-click

Establishes the rule according to which double-clicking on an nanoCAD object will call the edit dialog for this object or the properties bar. The setting has four parameters:

**Program objects** – when the option is enabled, edit command will be opened by double click, when disabled – object properties window. Applies to objects of all types, except for dimensions, texts and multiline texts;

**Dimensions, Texts, Multiline texts** – the option is similar to a previous one, but with help of three checkboxes it controls the result of double click on dimension, text and multiline text.

### Design

ESCD Standard:

 <b>Design</b>	
Use symbol scale	<input type="checkbox"/> No
Drawing scale	1:0
Model scale	1:0
Text wipeout offset	0.2
Cut CAD-platform elements	Wipeout

SPDS Standard:

 <b>Design</b>	
Use symbol scale	<input checked="" type="checkbox"/> Yes
Drawing scale	100.0
Model scale	1.0
Text wipeout offset	0.2
Cut CAD-platform elements	Wipeout

### Use symbol scale

The option is disabled:

- Design elements are inserted as 1:1 scale.
- Database objects are inserted with the current scale (line type scale is equal to 1).
- Measurements of dimensions (if they are not inside formats and not associated with nanoCAD Organization objects) take a scale factor that is reverse to the current scale.
- The mode is signaled by a small letter **m** on the **Scale** toolbar.

The option is enabled:

- Design elements are inserted with a current scale.
- Database objects are inserted with the scale specified in the insertion dialog box (by default 1:1). Line type scale is taken from the current scale.
- Measurements of dimensions (if they are not inside formats and not associated with nanoCAD Organization objects) use the scale factor 1.
- The mode is signaled by a capital letter **M** on the **Scale** toolbar.

By default, for the Organization standard the option is enabled, for ESKD format it is disabled.

#### *Text wipeout offset*

Sets the default offset of the geometry mark from the text.

#### *Cut CAD-platform elements*

Controls the overlap of nanoCAD primitives by design elements. Is reverse-acting. Acceptable values: **No, Cut, Wipeout**.

**Wipeout** – closes a primitive.

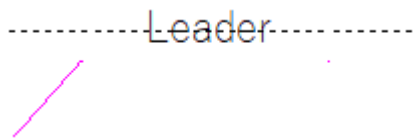

**Cut** – cuts a primitive section. When deleting or moving, the cut primitive returns its state.

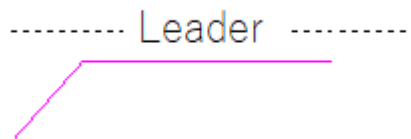

**No** – does not overlap a primitive.

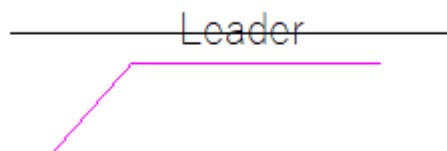

#### *Default Tab*

Allows you to set the default tab value in millimeters.

#### *Font size for fractions*

Sets the font size for fractions. Acceptable values: **One step less, Equal to the main**.

#### *List of drawing scales*

Sets the list of scales. Valid values: **Standard only, Document only, All**.

#### *Default text style*

Sets the default text style. Acceptable values: **GOST 2.304, Standard**.

#### **Notifications**



#### *Enable hints*

Enables or disables the display of hints in the notifier. The option does not apply to a notification with the **Error** status.

### Avoid mouse pointer

Enables or disables the mode of automatic displacement of hints not to interfere with the selection of objects.

### Hot keys



Hot keys are assigned to open **Quick Options** and **Notifications (notifier)** dialog boxes.

### Databases access



The database includes, in addition to standard elements, table and format templates, bolted assembly templates, groups and markers, as well as examples and other custom elements. The choice of a specific database is determined by configuration of the path to the data source.

**Data Source** – a path to the file of the standard objects database.

**ATTENTION!** When placing the nanoCAD database in a network resource, it is necessary to allow all users to write to the folder where the base is located. In this case, the file with the database itself can be read-only (then users will not be able to change the contents of the network database).

nanoCAD provides for work with both databases of standard MS Access products and MS SQL. When you click the  button, a dialog for specifying a data source appears in the **Data Source** field.

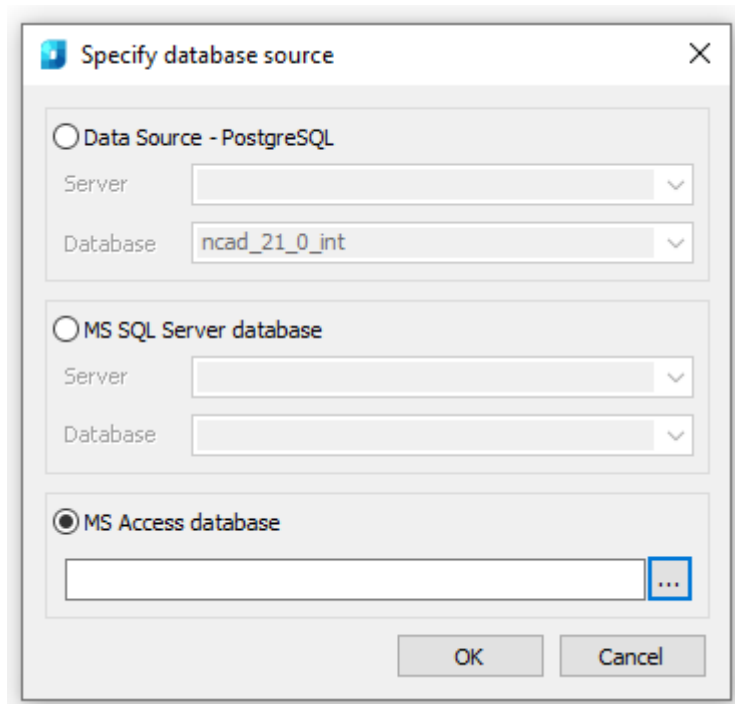

When using the MS SQL database, it is necessary to specify the server name in the **Server** field (along with the name of the SQL database server). For example: SERVER or SERVER\SQLEXPRESS.

In the **Database** field, it is necessary to specify the name of database to which connection is made.

If the MS Access database is used, it is necessary to select the **Database source - PostgreSQL** switch, and then specify a path to \*.mdf, \*.mcs files of the database. (A path can be a network one.)

**NOTE:** Database access settings are interface settings. Problems can occur when using disk compression with connection to local databases (for 64-bit versions).

**Standards filter** – filter for limiting the standards used. Possible standards: GOST, ISO, DIN, JUS, PN, CSN, GB, NF, IS.

## Standard Elements Tab

The **Standard elements** menu tab allows you to set parameters of imported IFC-objects.

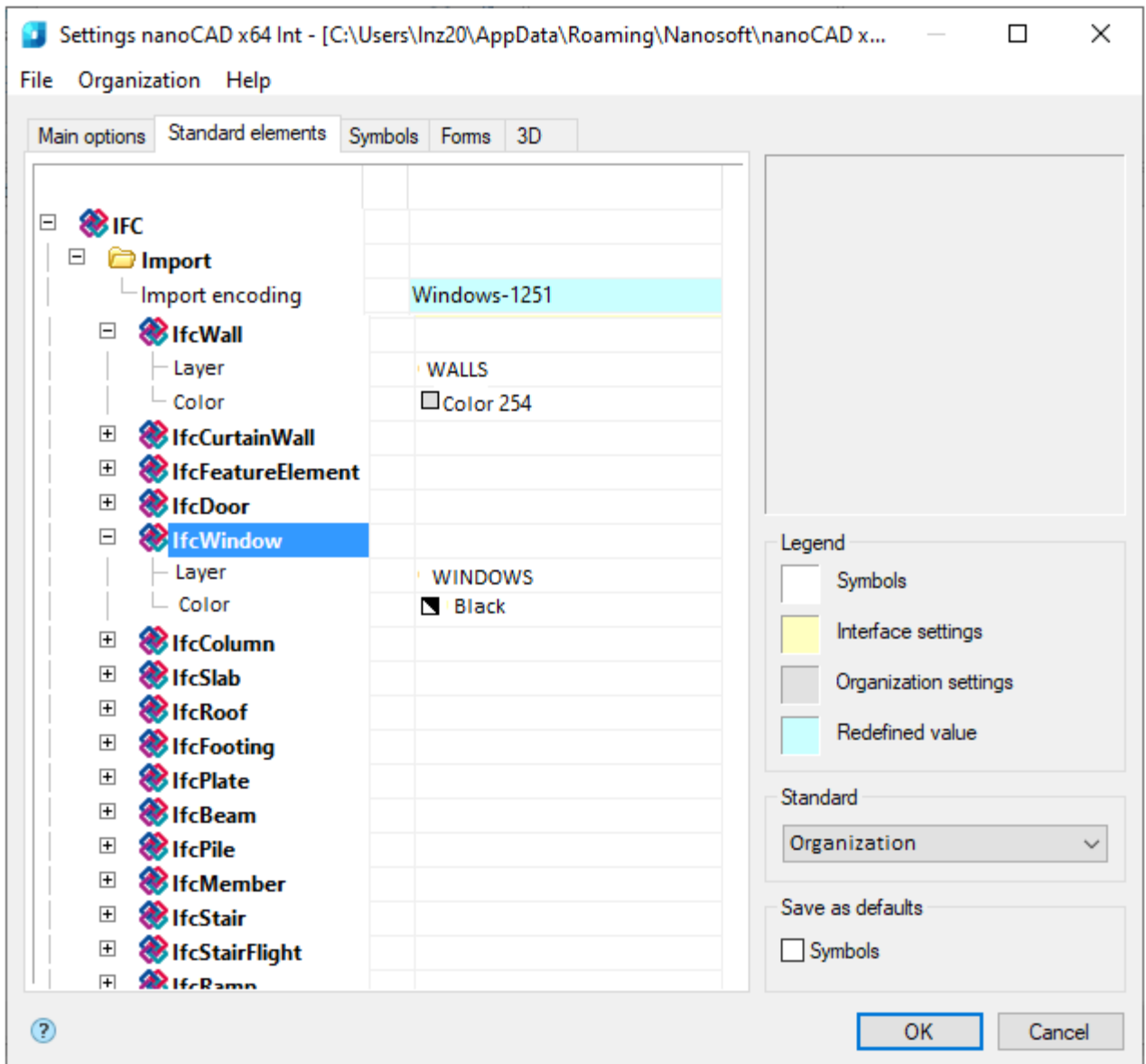

### Import encoding

ifc files can have different encodings. This parameter determines what encoding the files will be read in. This affects the display of object names.

## Symbols Tab

The **Symbols** menu tab is designed to display nanoCAD symbols.

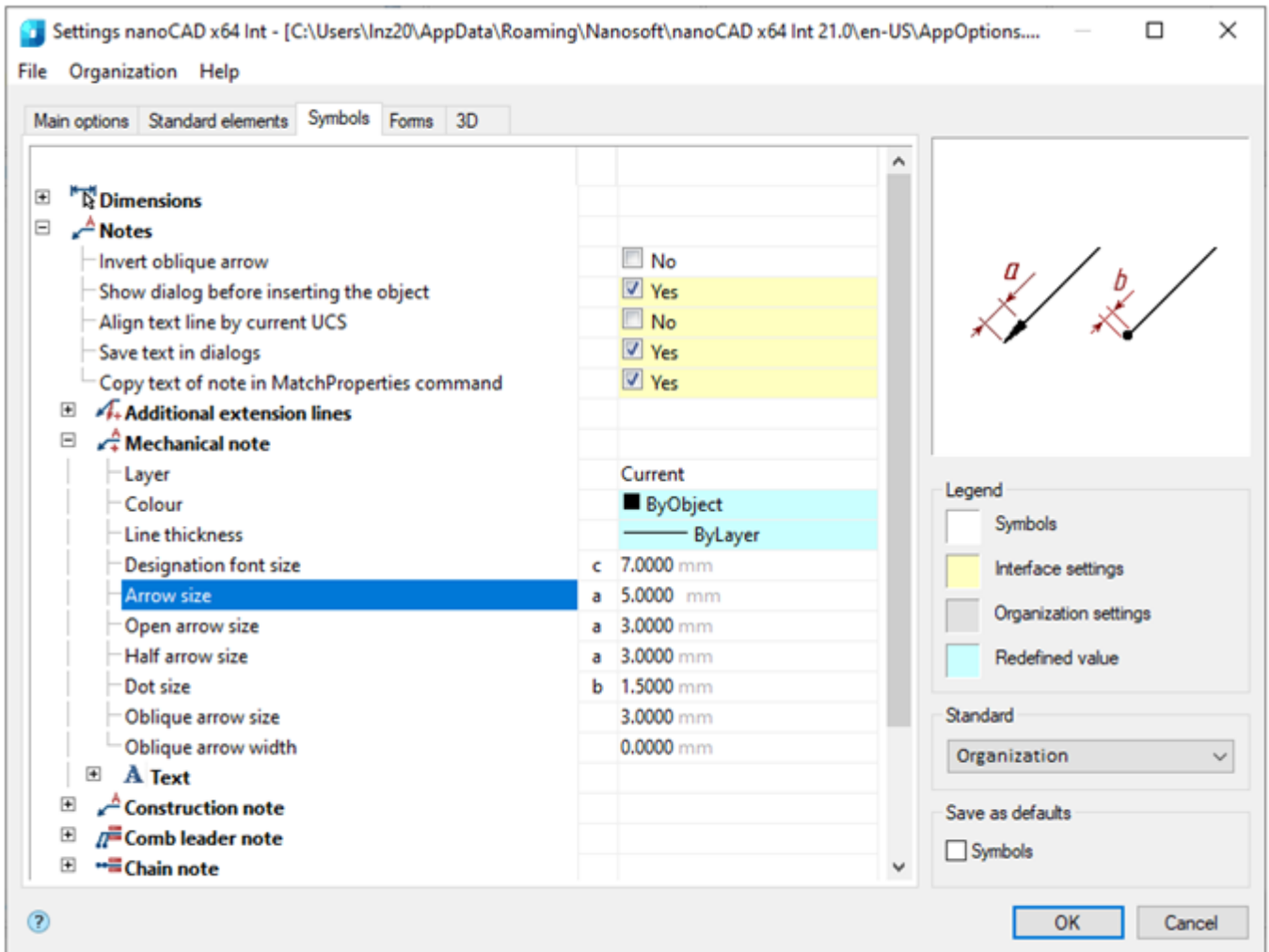

## Dimensions

Setting dimensions display parameters of nanoCAD. Allows you to change the layer into which new and copied dimensions, dialog settings, etc. are automatically inserted.

### Layer

Allows you to select the layer on which the new and copied dimensions will be placed by default.

### Apply layer for all new dimensions

When the option is enabled, the copied dimensions will be placed on a drawing layer selected for dimensions. When the option is disabled, dimensions are placed on the current layer.

### Ordinate dimensions

Controls built-in ordinate dimensions, can take **ISO** and **GOST** values. When the **ISO** option is enabled, the ordinate dimensions of the ISO standard built into the nanoCAD are used. When the **GOST** option is enabled, the ordinate dimensions of nanoCAD are used.



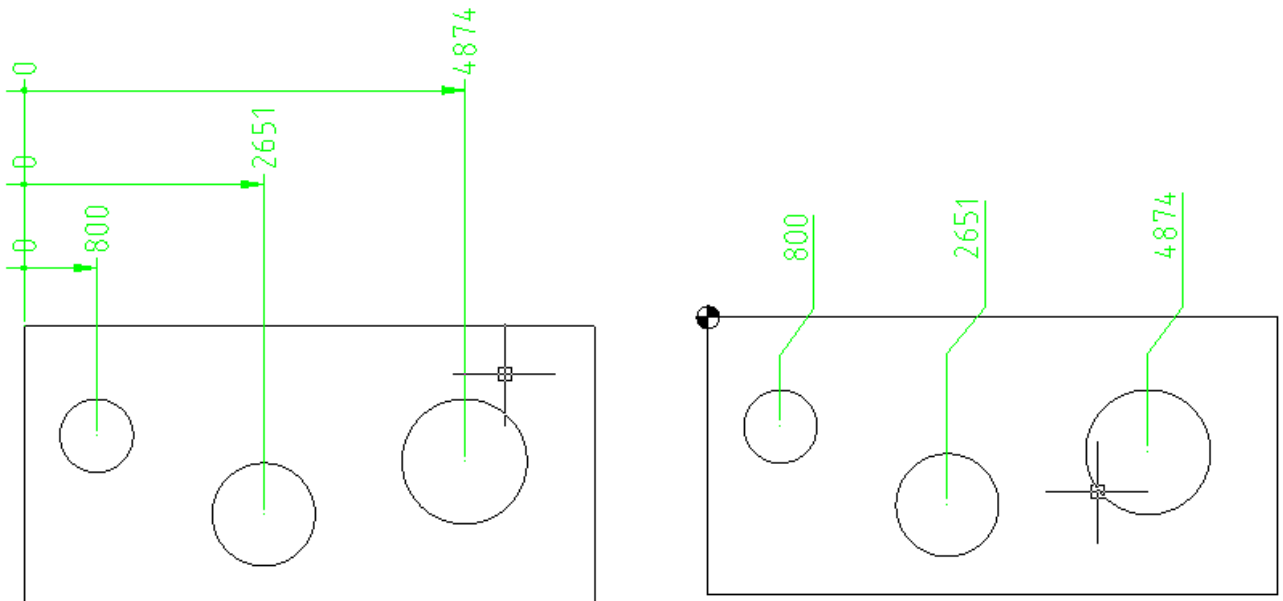

Left according to the GOST, right – to ISO

[Show dialog for new dimensions](#)

Controls automatic opening the dimensions dialog.

[Arrows in chains](#)

Replaces the arrows used in nanoCAD in dimensional chains. It is possible to replace with serifs, dots, or not replace at all.

[Auto-dimension mode indicator](#)

Controls the display of an additional indicator when using auto-dimension.

### Notes

Notes display options. Allow you to change the size of text, arrows, type of pointers, etc.

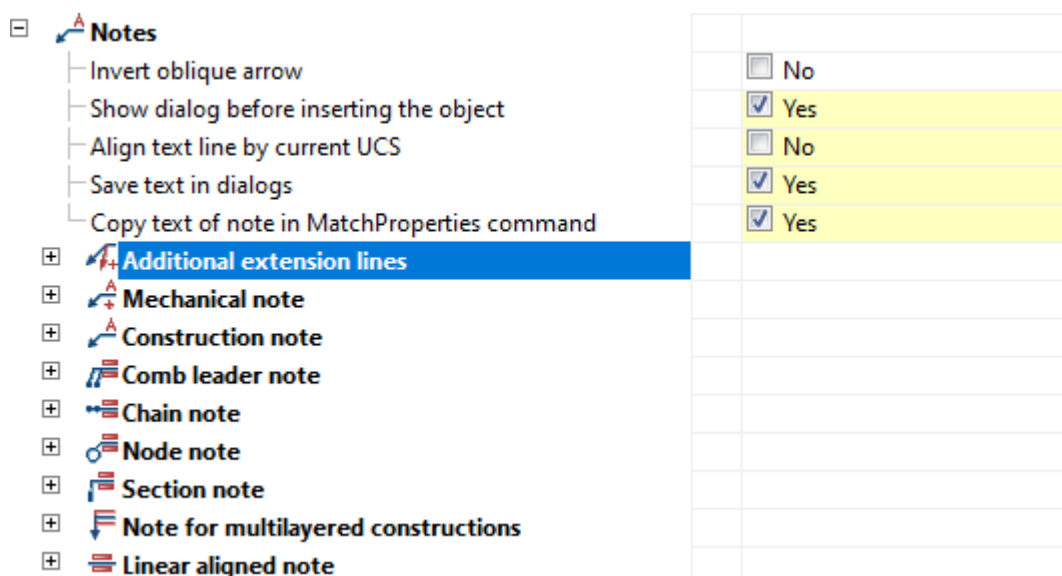

[Invert oblique arrow](#)

Allows you to select the direction of oblique arrow.

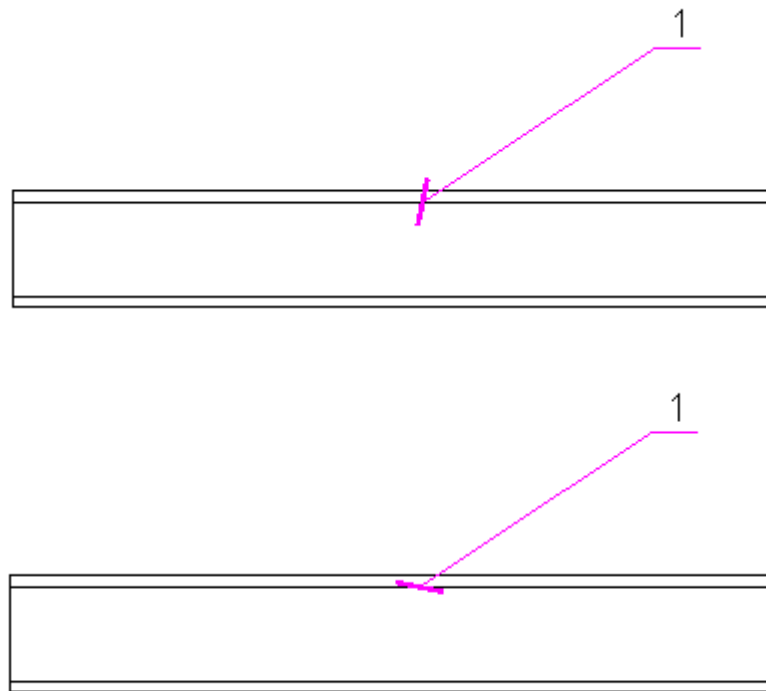

*Show dialog before inserting the object*

When the option is enabled, it shows insertion box before inserting a leader.

*Align text line by current UCS*

When the option is enabled, the text line is rotated in the direction of the right coordinate system.

*Save text in dialogs*

When the option is enabled, earlier inserted text remains in the insertion field when inserting the next leader.

*Copy text of note in MatchProperties command*

This option controls the ability to copy text when using the **Copy Properties** command.

The rest of options allow for changing dimension of text, pointers, line thickness, location layer, color, etc.

## **Forms Tab**

The **Forms** tab is designed to set parameters of text parts of tools to create standard drawing elements.

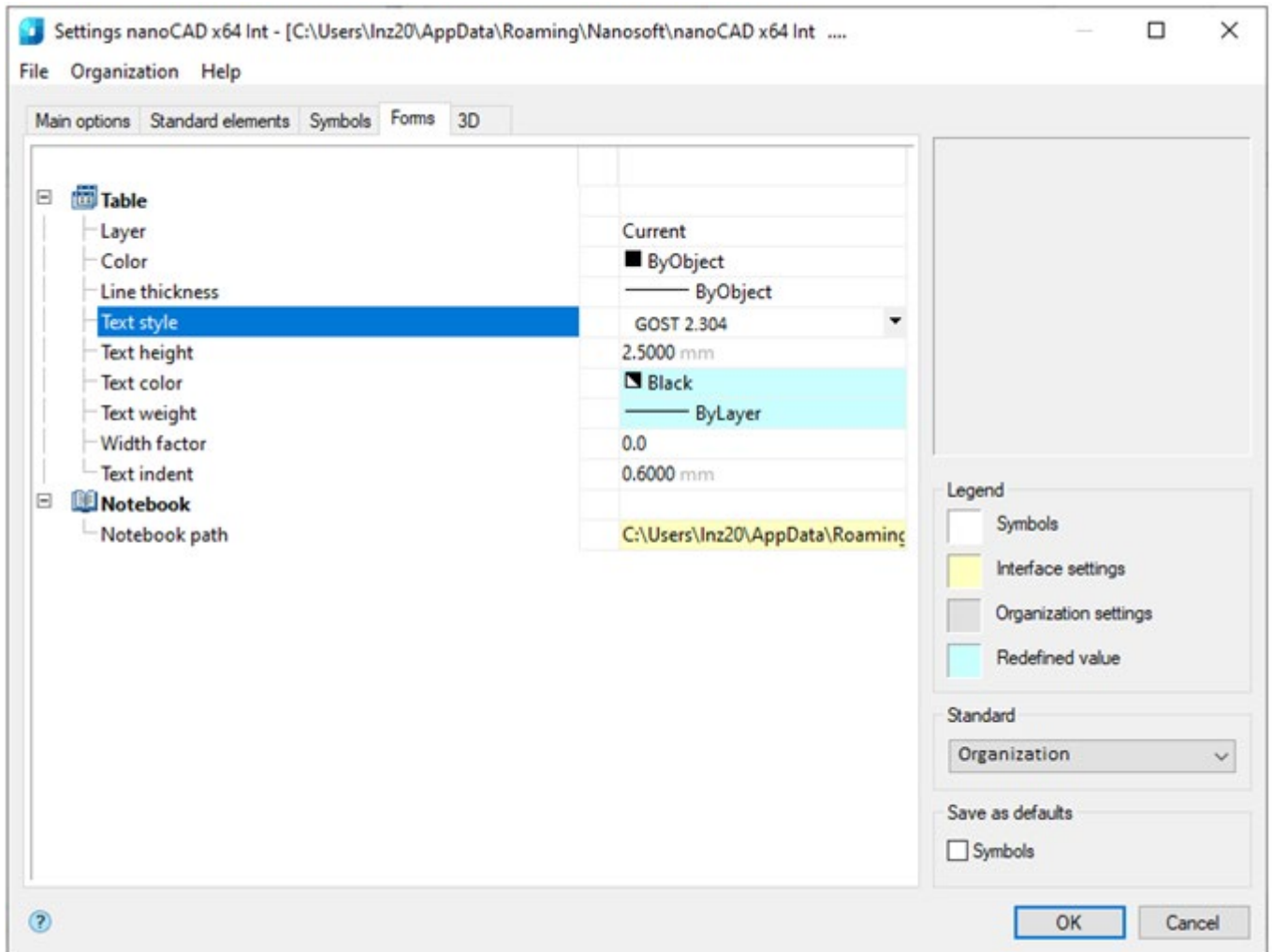

### Table

Setting display parameters of nanoCAD tables.

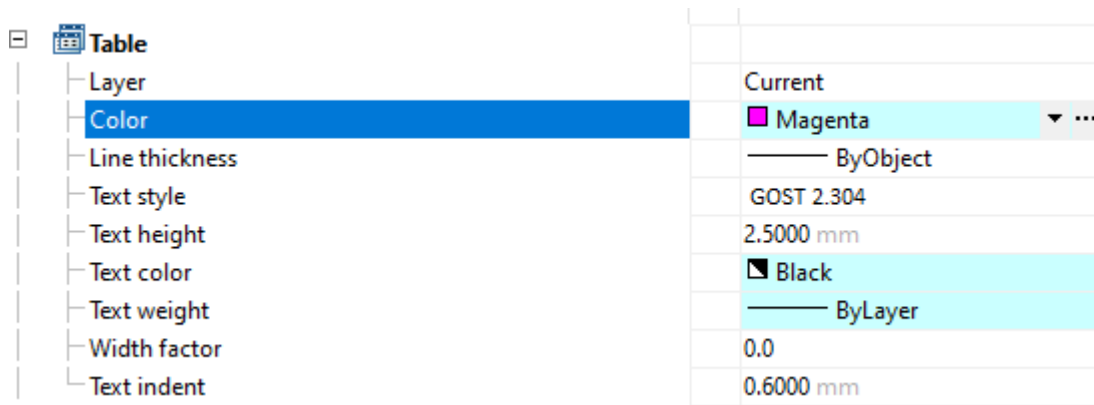

### Layer

Specifies the layer on which the inserted (created) table will be located by default.

### Color

Sets the color for table elements.

### Line thickness

Assigns thickness to border lines of table cells.

The **By layer** value corresponds to the standard thickness for the layer on which the tables are located by default. The **By block** value corresponds to the standard thickness for the block that

contains the table. Selecting **By Object** value sets the thickness specified manually for table objects. The **Default** value corresponds to the default line thickness for this drawing.

*Text style*

Sets the standard text style inside the table.

*Text height*

Allows you to set a standard value for the text height. You can select the height from a set of standard values according to GOST 2.304 or enter your own height value manually.

*Text color*

Controls the choice of text color in tables. You can choose a color from a standard set of values or set your own color from the built-in palette.

*Text weight*

Allows you to select the line thickness of text characters in the table. The **By layer** value corresponds to the standard thickness for the layer on which the tables are located by default. The **By block** value corresponds to the standard thickness for the block that contains the table. Selecting the **By object** value sets the thickness specified for table objects manually.

The **Default** value corresponds to the default line thickness for this drawing.

*Text indent*

Allows you to select the value of the text indentation from the cell borders.

**Notebook**

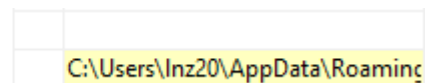
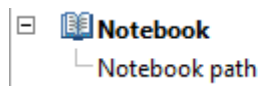

*Notebook path*

The path to the notebook file.

## 3D Tab

The tab is designed to configure the construction and display of 3D objects (solids).

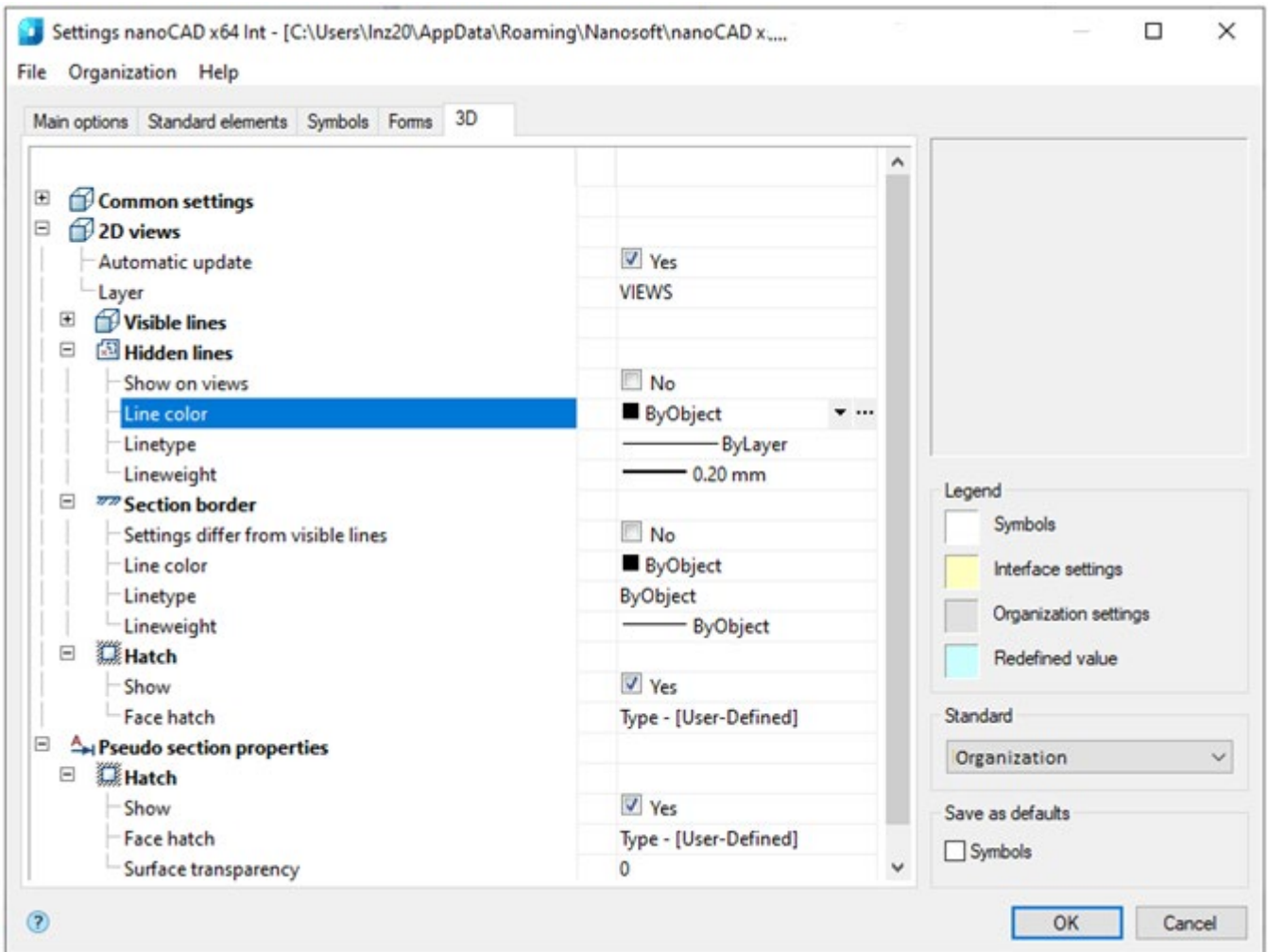

### Common settings

<input checked="" type="checkbox"/>	Common settings	
<input type="checkbox"/>	Automatically project edges on sketch	<input checked="" type="checkbox"/> Yes
<input type="checkbox"/>	Layer for sketches	SKETCHES
<input type="checkbox"/>	Layer for working objects	WORKING_ELEMENTS
<input type="checkbox"/>	Layer for sections	SECTIONS

#### Automatically project edges on sketch

If the option is enabled, then when you switch to sketch mode on a flat face of a solid, the edges of the face are automatically projected onto the flat sketch.

#### Automatically project the origin point on new sketch

Controls the creation of the origin point projection when creating a new sketch.

#### Automatically correct UCS while editing block reference with 2D constraints

Automatic correction of UCS while editing a block reference with 2D constraints.

#### Restore viewport's camera while exiting 2D sketch editing mode

If enabled, the viewport camera will be in position before the sketch is edited.

#### Edit parametric constraint value upon creation

Controls the opening of the constraint editing dialog immediately after installation.

#### Associativity for new bodies

The enabled parameter allows you to build fixed bodies without the possibility of defixation. At that, the sketch should be attached to some plane.

*Layer for sketches*

Name of layer for locating sketches.

*Layer for working objects*

Name of layer for working objects.

*Layer for sections*

Name of layer for sections.

*Layer for parametric 3D solids*

Allows you to customize the name of the layer on which parametric 3D bodies will be located.

*Show thread helix*

Controls the display of the thread helix.

*Thread helix color*

Thread helix color.

*Thread face color*

Thread face color.

*Mass display precision*

Mass display precision for inspector properties and part and assembly properties.

**2D Views**

[-] 2D views	<input checked="" type="checkbox"/> Yes
Automatic update	VIEWS
Layer	
[-] Visible lines	<input checked="" type="checkbox"/> Yes
Show on sections	■ ByObject
Line color	ByObject
Linetype	——— ByObject
Lineweight	
[-] Hidden lines	<input type="checkbox"/> No
Show on views	■ ByObject
Line color	——— ByLayer
Linetype	——— 0.20 mm
Lineweight	
[-] Section border	<input type="checkbox"/> No
Settings differ from visible lines	■ ByObject
Line color	ByObject
Linetype	——— ByObject
Lineweight	
[-] Hatch	<input checked="" type="checkbox"/> Yes
Show	Type - [User-Defined]
Face hatch	

*Automatic update*

Controls the automatic update of views from a model after a solid is changed.

*Show thread*

Controls the thread display.

*Layer*

Name of layer for 2D views.

### Visible lines

**Show on sections** - controls the display of visible lines in sections.

**Line color** - determines the color of visible lines.

**Linetype** - determines the type of visible lines.

**Lineweight** - determines the weight (thickness) of visible lines.

### Hidden lines

**Show in views** - controls the display of hidden lines in views

**Line color** - determines the color of hidden lines.

**Linetype** - determines the type of hidden lines.

**Lineweight** - determines the weight of hidden lines.

### Section border

**Settings differ from visible lines** - controls the settings of the lines of section borders, which (settings) can be the same or different from the settings of visible lines. If **No**, then the next three parameters are not used.

**Line color** - determines the color of section border.

**Linetype** - determines the type of section border.

**Lineweight** - determines the weight of section border.

### Hatch

**Show** - controls the display of hatch.

**Face hatch** - assigns the type of face hatch.

### Pseudo section properties

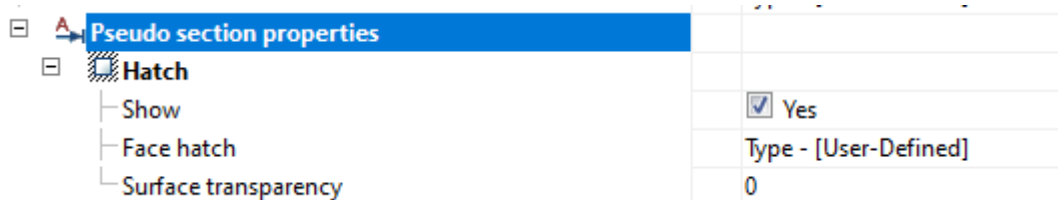

### Hatch

**Show** - controls the display of hatch on pseudo section.

**Face hatch** - assigns the types of face hatch.

**Surface transparency** - sets the transparency factor for the surface (0 - full transparency).

## Quick Options

Hot keys for opening the quick options window are set on the **Main options** tab:



Quick options dialog box contains the most common options for design elements:

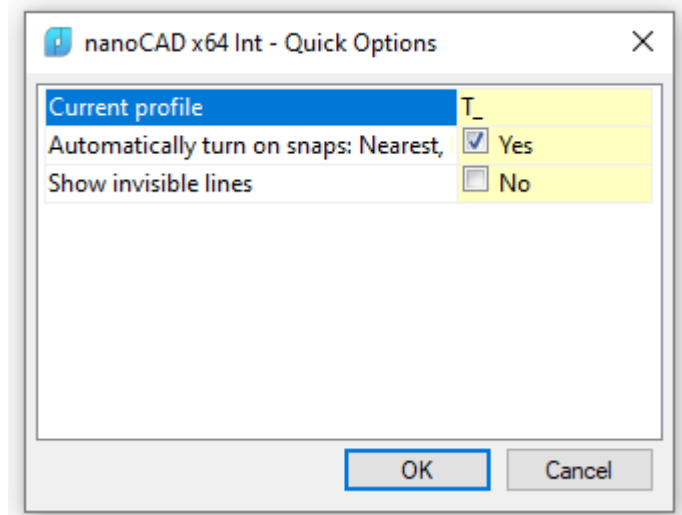

Current profile - allows you to select a settings profile;

Automatically turn on snaps - controls the automatic activation of snaps Nearest, Endpoint, Quadrant, Center, Intersection when inserting objects from the database;

**Show invisible lines** – controls the display of invisible lines.

## *Settings of Layers Profiles*

Layers profiles are used to organize different divisions of the design work within one drawing file. Every user works with their own group of layers.

For example, you have to annotate a drawing with leaders set separately by the compliance supervisor and the technologist.

### *Do:*

1. Switch to the **Symbols** tab in the **Settings** dialog, select the **Leader note** in the **Notes** section, in the **Layer** field select the **<Table of layers>**:



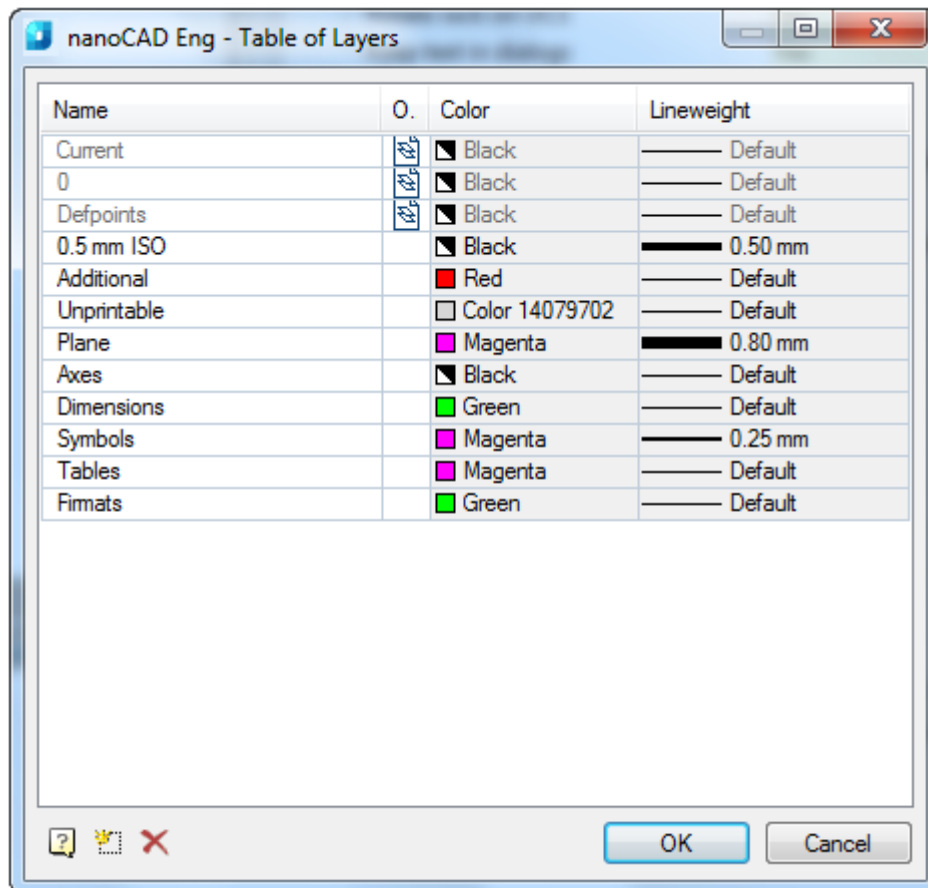

**NOTE:** The  button opens the **Table of layers** dialog too.

2. Select the  **New layer** button to create a new layer. By default, a new layer will have a *LayerN* name, where *N* – layer's number.
3. Click on the created layer's name to rename it. Type a new name – *Notes*:

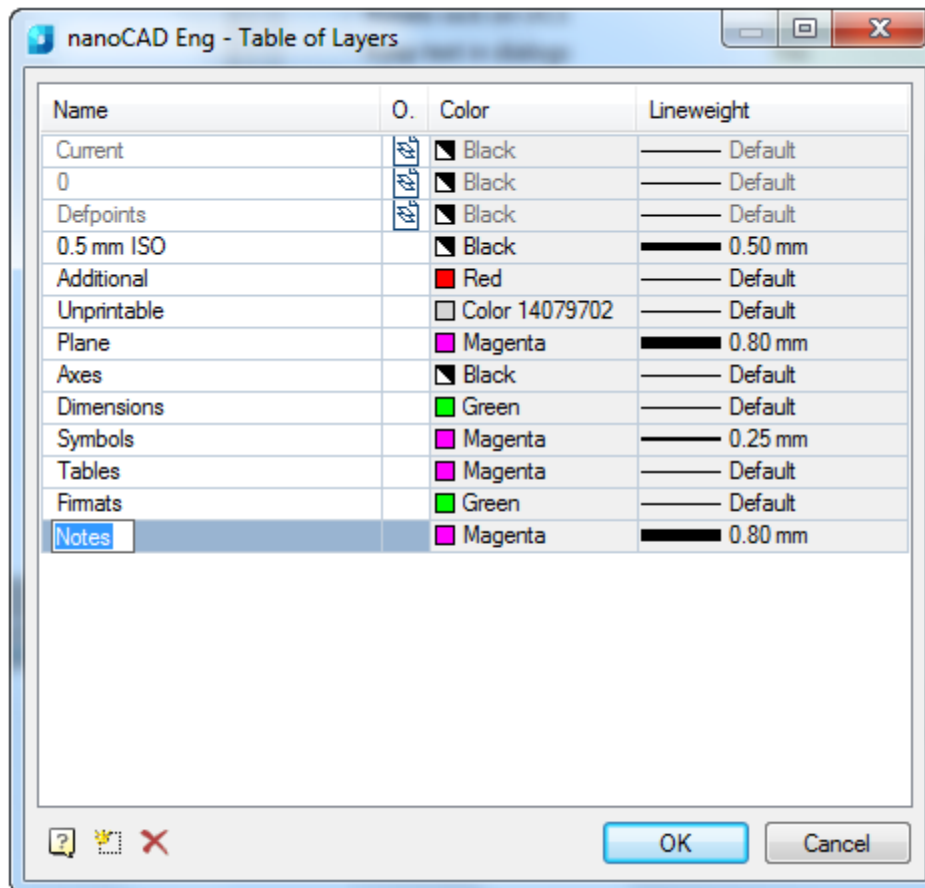

4. Select **OK**.
5. Select **OK** to close the **Settings** dialog box.
6. In the **Save changes?** dialog box select the **Save to config file and current document** parameter and select **OK**:

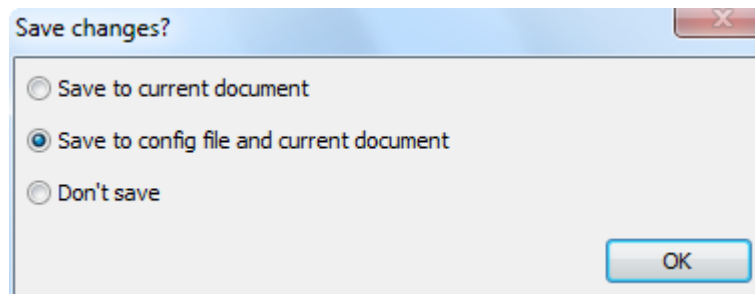

**NOTE:** When saving settings in a configuration file (not in a current document), all notes will be created on the *Notes* layer by default. It does not matter whether this layer is in the document. If a layer does not exist, it will be created with the parameters specified in the **Table of layers** dialog box.

To separate the work of the compliance supervisor and the technologist, create layers profiles.

7. In the **Settings** dialog switch to the **Main options** tab and in the **Common settings** section in the **Current profile** select the  to open the **Table of profiles** dialog:



As a result of the settings, according to which profile is set as current, you can create:

- Technologist's annotation on the *T\_Notes*;
- Compliance supervisor's annotation on the *CS\_Notes*;
- Leader note on the *Notes* layer.

**To create technologist's annotation:**

1. Select **CTRL** + **SHIFT** + **Q** hotkeys to open the **Quick Options** dialog box:

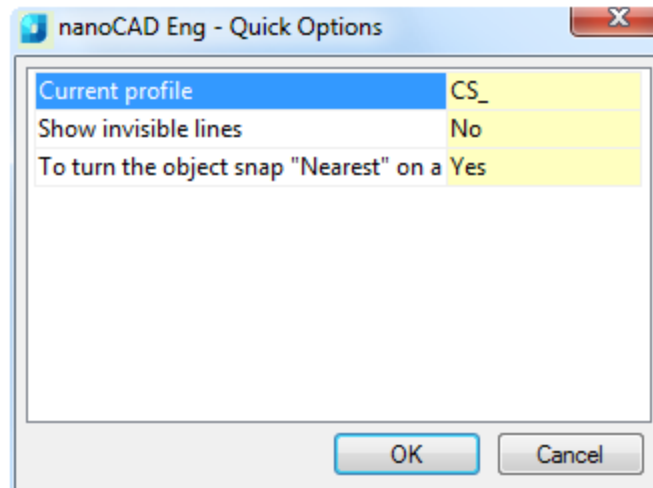

2. Select the *T\_* profile from the drop-down list:

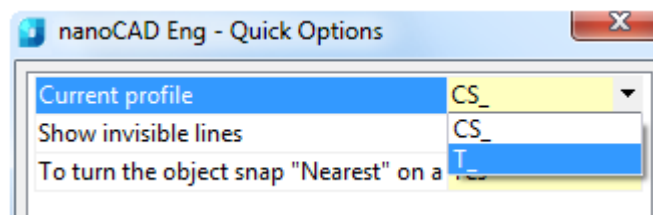

3. Select **OK**.
4. Create an annotation using the **Notes>Universal notes** command from the **Draw** menu. When the first annotation is being created, a new *T\_Notes* layer is created on the *Notes* layer base:

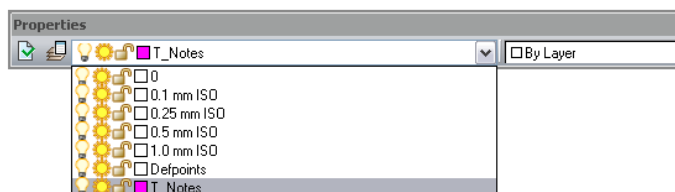

Technologist's annotation

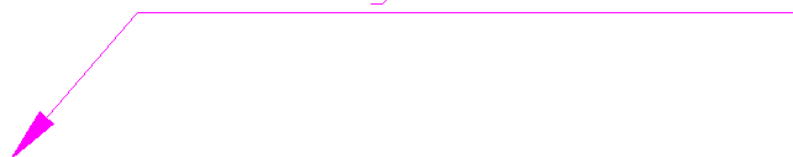

**To create the compliance supervisor's annotation:**

1. Select **CTRL** + **SHIFT** + **Q** hotkeys to open the **Quick Options** dialog box.

2. Select the **CS\_** profile from the drop-down list.
3. Select **OK**.
4. Create an annotation using the **Notes>Universal notes** command from the **Draw** menu. When the first annotation is being created, a new **CS\_Notes** layer is created on the **Notes** layer base:

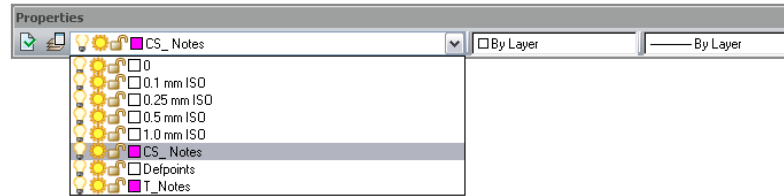

Compliance supervisor's annotation



#### To create a universal note:

1. Open the **Settings** dialog box.
2. Open the **Table of profiles** dialog box.
3. Select **NO PROFILE**.
4. Twice select **OK** to close the dialog boxes.
5. Create a universal note. When the first annotation is being created, a new **Notes** layer is created:

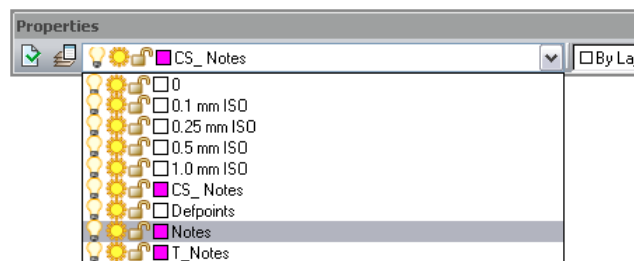

Universal note



To enhance visualization, you can set different colors for the *Notes*, *CS\_Notes* and *T\_Notes* layers.

Do:

1. Switch to the **Symbols** tab in the **Settings** dialog box and in the **Notes – Universal note** section select **By layer** in the **Color** and **Text color** fields.
2. Select **OK** in the **Settings** dialog box.

3. In the **Save changes?** dialog box select the **Save to config file and current document** parameter and select OK.
4. In the **Layers** dialog specify the colors for the layers.

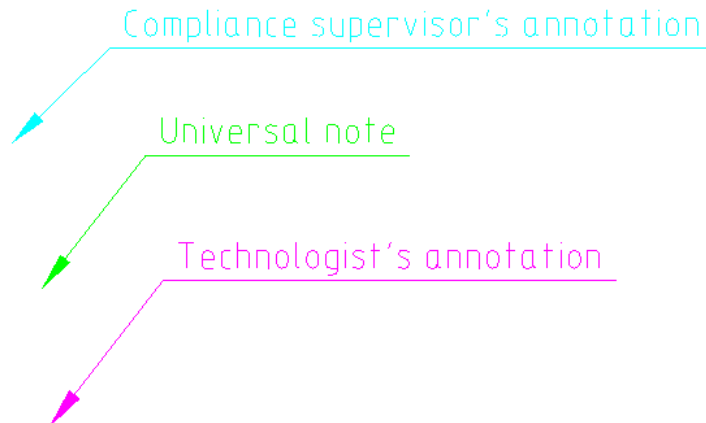
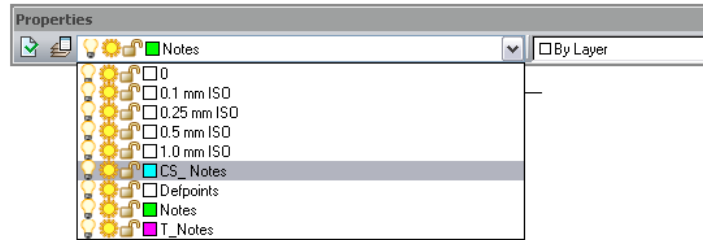

**NOTE:** Hotkeys for the **Quick options** dialog box are specified in the **Hotkeys** section in the **Main options** tab of the **Settings** dialog box:

Hot keys	
Call dialog <Quick Options>	CTRL + SHIFT + Q
Call Notify Window	CTRL + SHIFT + W

## Saving and Transferring Settings to Another Computer

There are three types of settings in nanoCAD – symbols, *interface settings* (highlighted yellow) and *organization settings*:

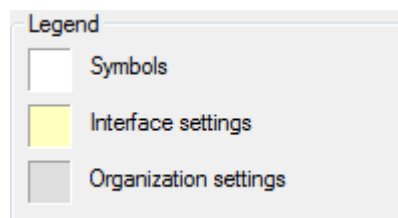

The settings are automatically saved in a separate file and read when creating a new document:

- Interface settings affect the operation of the application.
- Settings for design elements determine how a drawing designed using nanoCAD will look.

To use the settings made for design elements by default, check the **Design Settings** box in the **Save as default** section. The established parameters of the design elements settings items will be applied by default for all new documents, as well as for newly created design elements in the current document.

Otherwise, all settings changes will be valid only in the current program session.

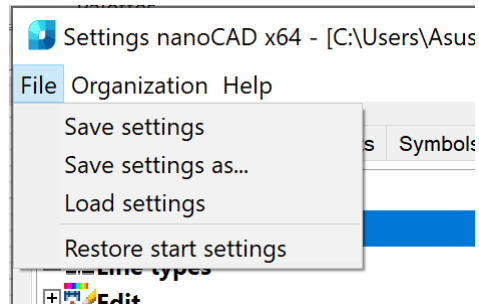

Saving, loading and restoring settings for design elements is managed in the **File** menu of this dialog:



### Parameters:

- Save settings**      Saves the design element settings in the current document.  
 When a new document is created, the settings will be the same as the settings set in a configuration file; the setting will only be applied to the current document.
- Save settings as...**      Saves settings in a separate file for later use.
- Load settings**      Loads saved settings from a file .
- Restore start settings**      Restores the settings supplied with the program

## Drawing Units

-  Ribbon: **Home – Properties > Units**
-  Menu: **Format – Units...**
-  Command line: **UNITS, UN**

The command opens the **Drawing Units** dialog box, where you can define the format and accuracy of the linear and angle units.

By default, the base direction to measure angles is to the right of the initial point (East). Angles should be measured in a counter clockwise direction to give positive numbers.

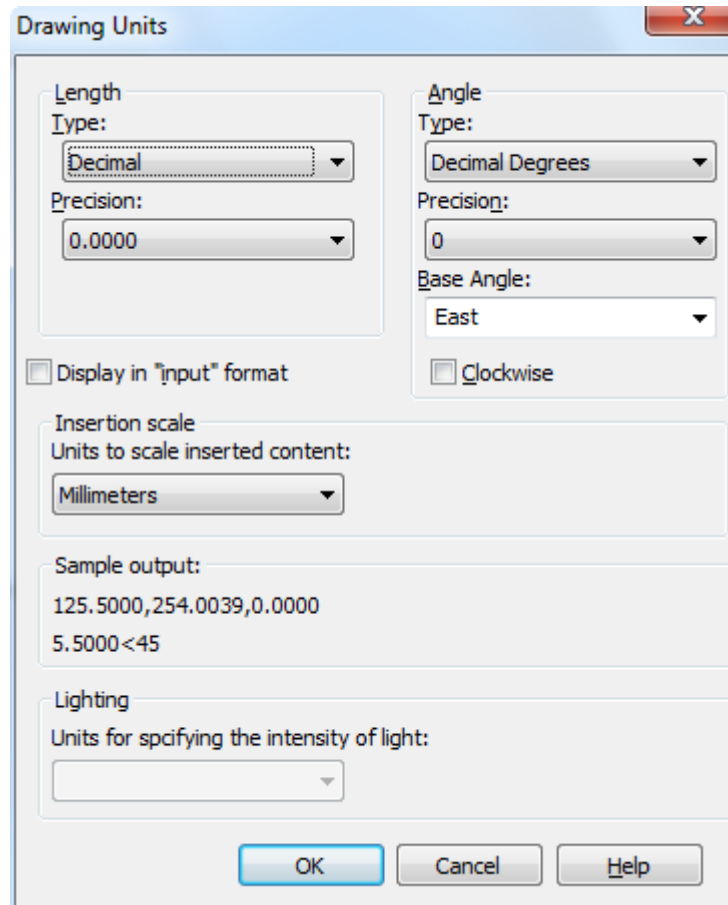

### **Parameters:**

#### *Linear*

**Type:** Current format of linear units.  
Available formats in the drop-down list:

- **Architectural**
- **Decimal**
- **Engineering**
- **Fractional**
- **Scientific**

**Precision:** Accuracy of current linear units.

#### *Angle*

**Type:** Current format of angle units.  
Available formats in the drop-down list:

- **Deg/Min/SEC**
- **Grads**
- **Decimal degrees**
- **Radians**
- **Surveyor's units**

**Precision:** Accuracy of current angle units.



**Base Angle:** Direction of base angle.  
Available formats in the drop-down list:

- **East**
- **North**
- **West**
- **South**
- **Pick angle** – by specifying two points in the graphic area.

**Clockwise** To change positive direction to measure angles to clockwise.

Display in "input" format Enables/disables display of drawing units without spaces.

#### *Insertion scale*

**Units to scale inserted content:** Units to measure blocks and external references, inserted in a document. If a block or inserted document was created with units which do not coincide with the units set in this section, the block or inserted document will be scaled to the specified units. Scale is defined by the ratio of units in an inserted document and a current document.  
If the **Undefined** option is selected, the insertion is performed without scaling.

#### *Sample output*

Preview of current linear and angle units set in the dialog box.

#### *Lighting*

**Units for specifying the intensity of light:**

Selecting light intensity units and lighting type. The following options are available in the drop-down list:

- **Generic** – standard lighting is included without lighting fixtures, lighting intensity units are not used (system variable LIGHTINGUNITS = 0);
- **American** – photometric lighting is included, American units of lighting intensity are used - *Foot-candle* (LIGHTINGUNITS = 1);
- **International** – photometric lighting is included, the lighting intensity units of the International System of Units (SI) are used - *Lux* (LIGHTINGUNITS = 2, default value).

## **Scale List**

In most cases, drawings are printed at an accurate scale.

When printing a model space, the plot scale is set in the **Plot** dialog box. This scale determines the ratio of the unit of length in the printed drawing to the real unit used in creation of the drawing.

When printing one of layout tabs, the scale is applied to the model itself displayed in the layout viewports. It defines, for each viewport, the ratio of the paper format dimensions to the model dimensions in the viewport.

Standard scales are available from the list of scales in the corresponding nanoCAD tools:

In the **Plot** dialog box:

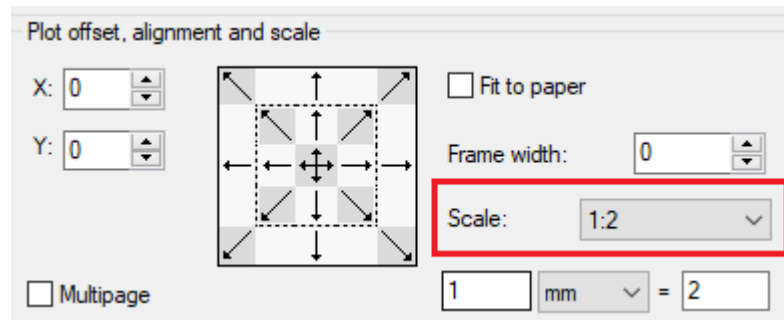

For a selected or active viewport:

- in the status bar

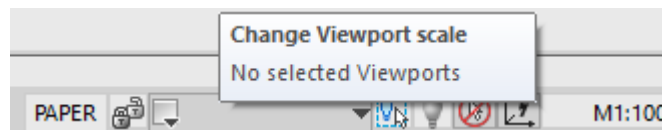



- in the **Properties** toolbar.

The list of scales is managed in the **Edit drawing scales** dialog box

 Ribbon: **Annotate – Annotation scaling > Scale List**

 Menu: **Format – Scale List Edit...**

 Command line: **SCALELISTEDIT**

 Non-dialog mode: **-SCALELISTEDIT**

In the dialog, you can add new scales, edit the existing ones, rebuild the scale list and delete unnecessary ones.

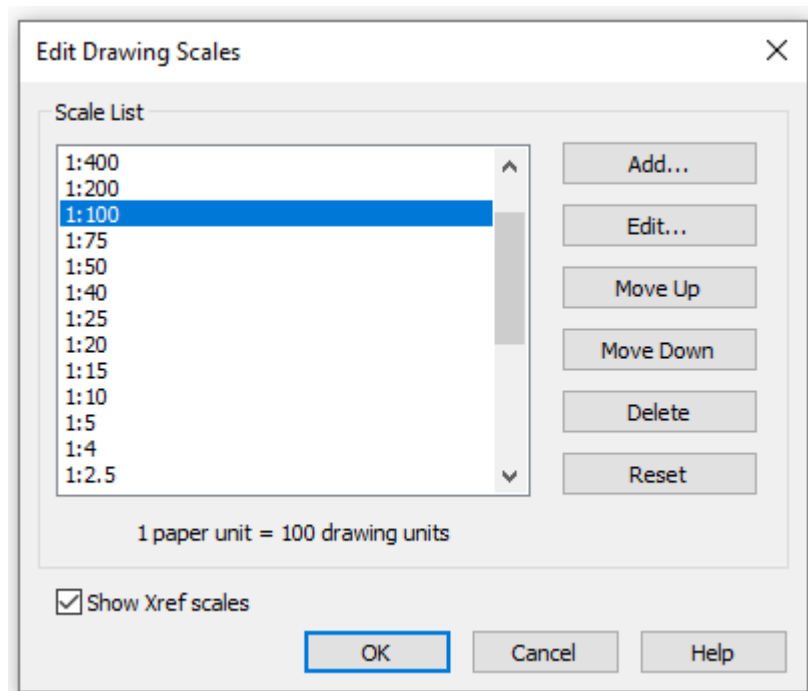

### Options:

**Scale list** Displays the content of the current scale list.

Add...

Opens the **Add Scale** dialog box to create a new scale. The dialog box sets the following parameters:

**Scale name** to be displayed in the Scale list.

**Scale properties** – ratio of paper units to drawing units.

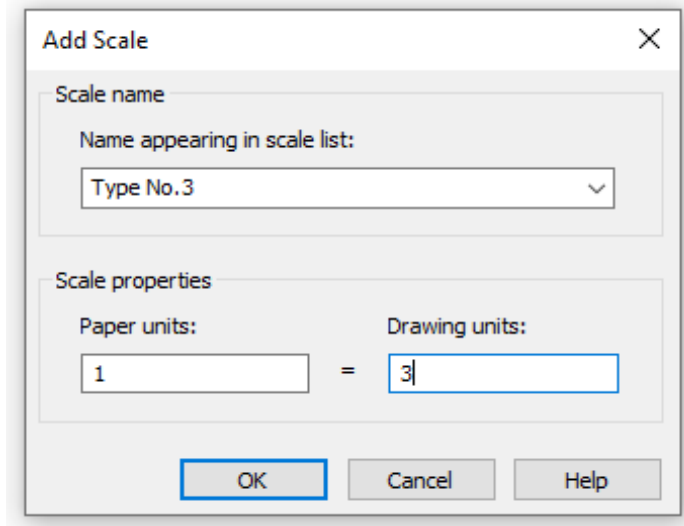

Edit...

Opens the **Edit scale** dialog box to edit parameters of the selected scale.

Move Up

Moves the selected scale one position up or down in the list.

Move Down

Delete

Deletes the scale selected in the list.

Reset

Deletes all custom and unused scales and restores the standard scale list. In the **Reset** dialog box, select the scale list to be restored.

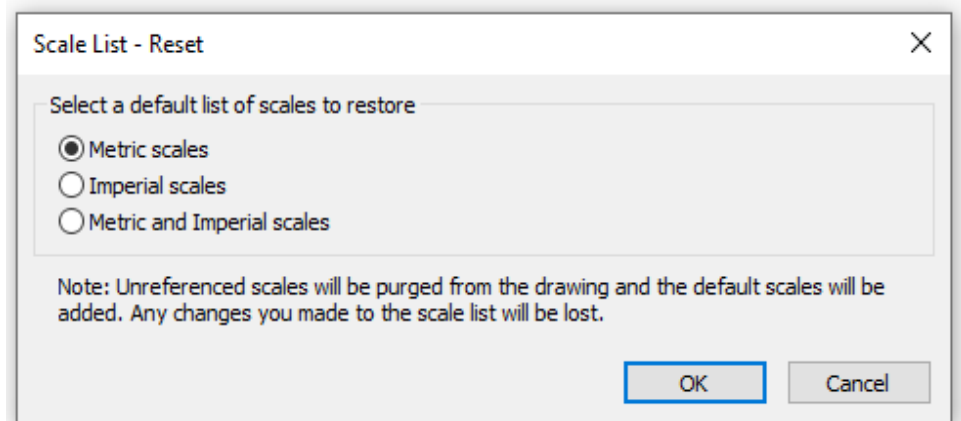

**Show xref scales**

Enables the display of scales contained in external references and different from the document scales in the scale list.

The xref scales are also available for editing.

To display the standard scales in certain units of measurement in the list, press **Reset** button, in the **Scale List** dialog box select to restore the list of scales in required units.

## Symbol Scale and Measurement Scale

There are two types of scale: symbol scale and measurement scale. The values for any of these scales can be set for any object, group of objects or document. New objects inherit the scale values from the document.

**NOTE** The list of values of established scales corresponds to ESKD GOST 2.302-68 “Scales”.

### Specifying Scale

To set scale, use the scale button on the status bar.

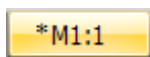

This button displays the scale of the selected objects. If objects are selected, an asterisk symbol is displayed before the scale value (scale 1:1 means that 1mm of object equals 1 unit of drawing).

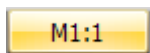

If there are no objects selected, the button displays the document scale but the asterisk is absent.

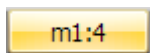

If the symbol scale value is displayed, the **m** character is in lower case. If the measurement scale value is displayed, the **M** character is in upper case.

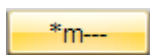
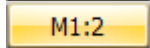

If the selected object does not support the selected scale, or selected objects have different scales, the scale value is not displayed.

#### To specify scale:

1. Select objects. To change the scale of all objects in the drawing, select all objects. If no objects are selected, a new scale will be set only for new objects that are created.
2. Select the scale button in the status bar.
3. Select the scale type in the menu (**Symbol scale** or **Measurement scale**) and specify the scale value from the list.

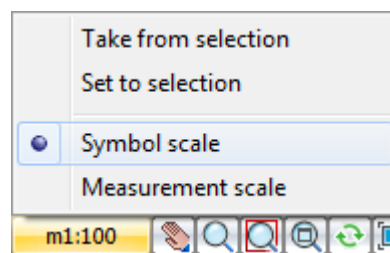

You can set the scale for the selected objects or take the scale value from the selected object.

#### To apply the scale to the selected objects or to take the scale from the selected object:

1. Select the scale button.
2. In the menu that opens, select the scale type (**Symbol scale** or **Measurement scale**).
3. Select **Set to selection**.

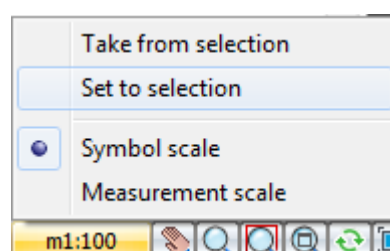

4. Select the objects on the drawing whose scale you want to change.

**To copy the scale from a selected object:**

1. Select scale button.
2. In the menu that opens, select the scale type (**Symbol scale** or **Measurement scale**).
3. Select Take from selection.
4. Select the object in the drawing whose scale you want to copy.

## Symbol Scale

**Symbol scale** is a settings parameter which decreases or increases the annotation objects in the drawing. This scale type is used for adjusting the display of annotation if it is too small or too big; for example, to change the size of an object's arrows and text. This scale has no influence on the size of other objects.

**Symbol scale** affects:

- Annotation objects.
- Linetypes with gaps and text.
- Dimensions and special text.

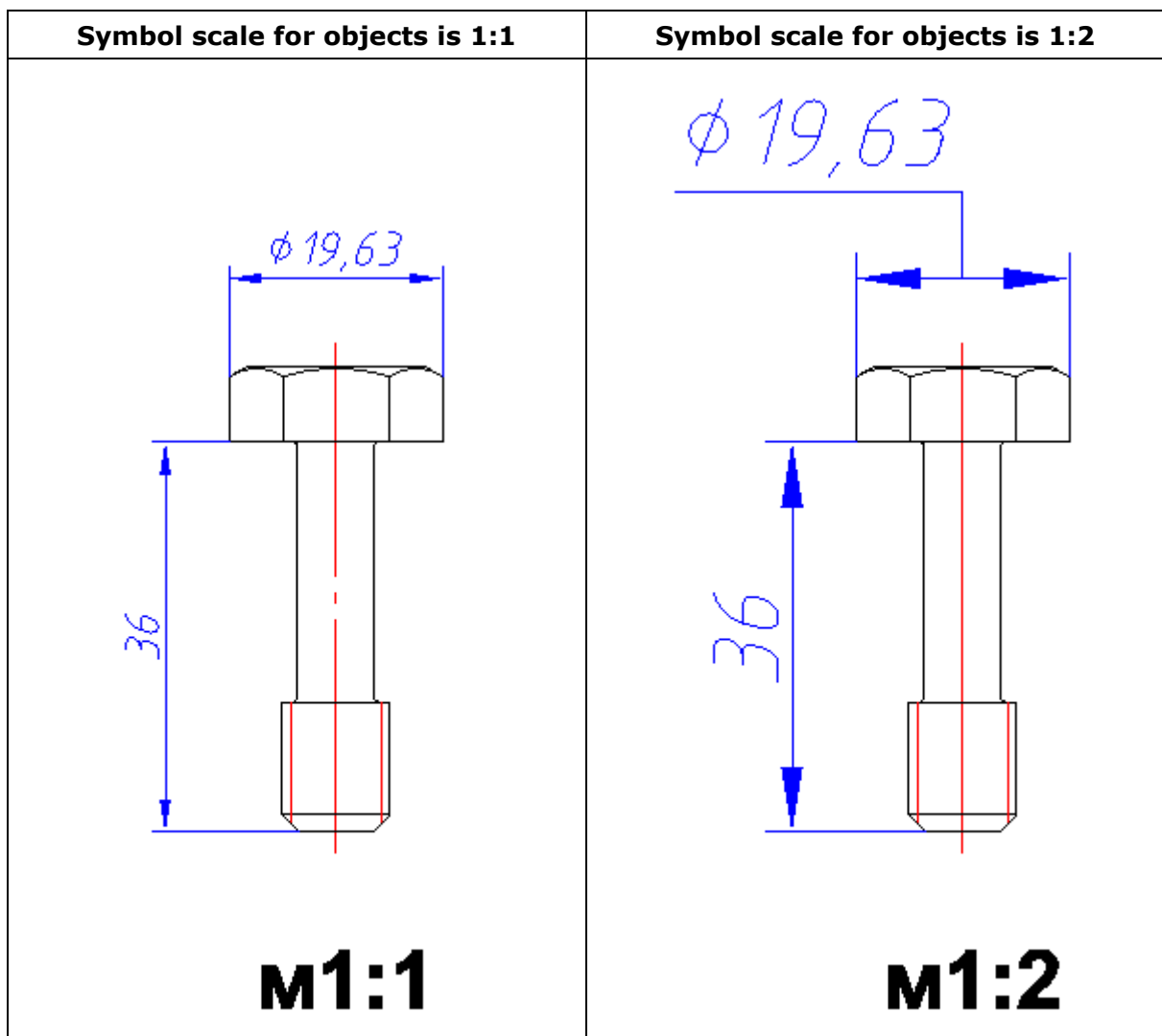

### To set symbol scale:

To set and change scales, use the scale button in the status bar. If the value is set to symbol scale, the **m** character is in lower case: m1:4

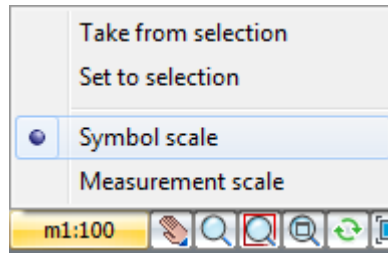

### Example of changing the symbol scale of a dimension object:

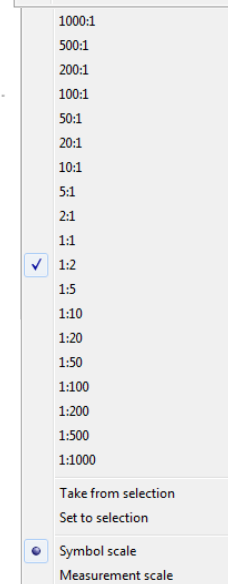
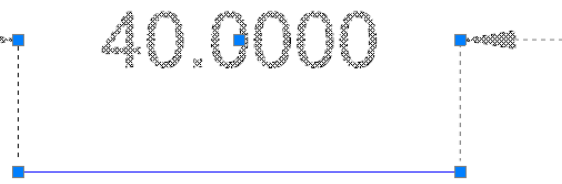
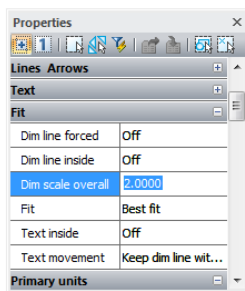
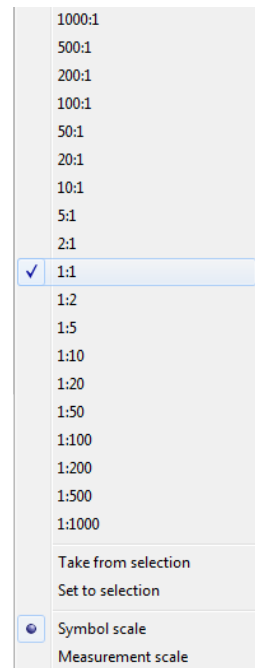
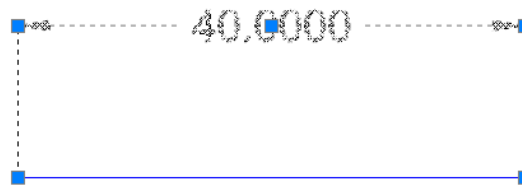
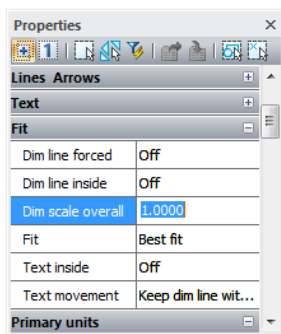

## Measurement Scale

This scale influences objects, but the size of the annotation of the objects stays unchanged. Linear dimensions are also scaled.

**Measurement scale** can be set for the following objects:

- **Dimension objects; measurement scale** influences the dimension text.
- **Special object from vertical applications** can have influences on the **measurement scale** of an object size in the drawing.

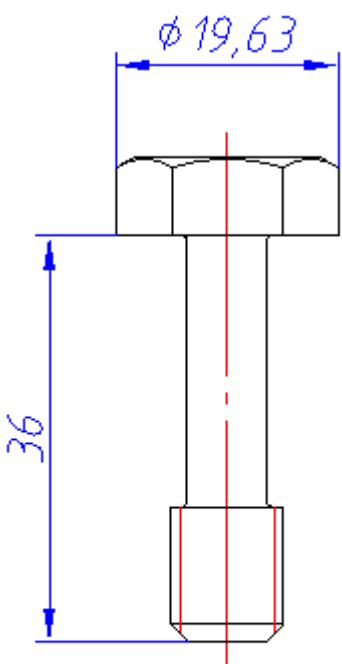
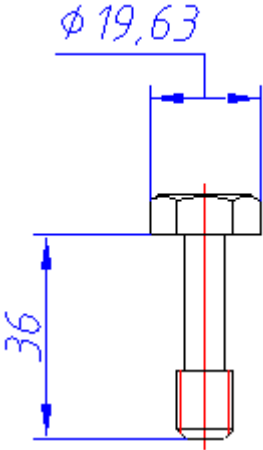
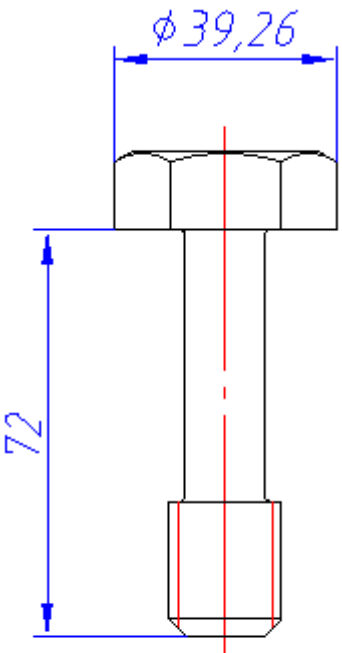
Measurement scale for all objects is 1:1	Measurement scale for all objects is 1:2	Measurement scale for dimension objects is 1:2 and for object is 1:1
 <p style="text-align: center;"><b>M1:1</b></p>	 <p style="text-align: center;"><b>M1:2</b></p>	 <p style="text-align: center;"><b>M1:2</b></p>

Use this scale if the drawing has a scale that differs from 1:1 scale.

**To set measurement scale:**

To set and change scales, use the scale button in the status bar. If the measurement scale value is set, the **M** character is in upper case: M1:1

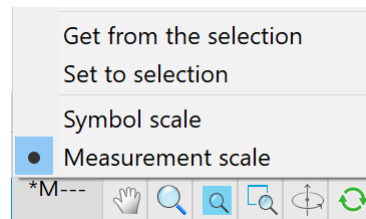

### Example of changing the measurement scale:

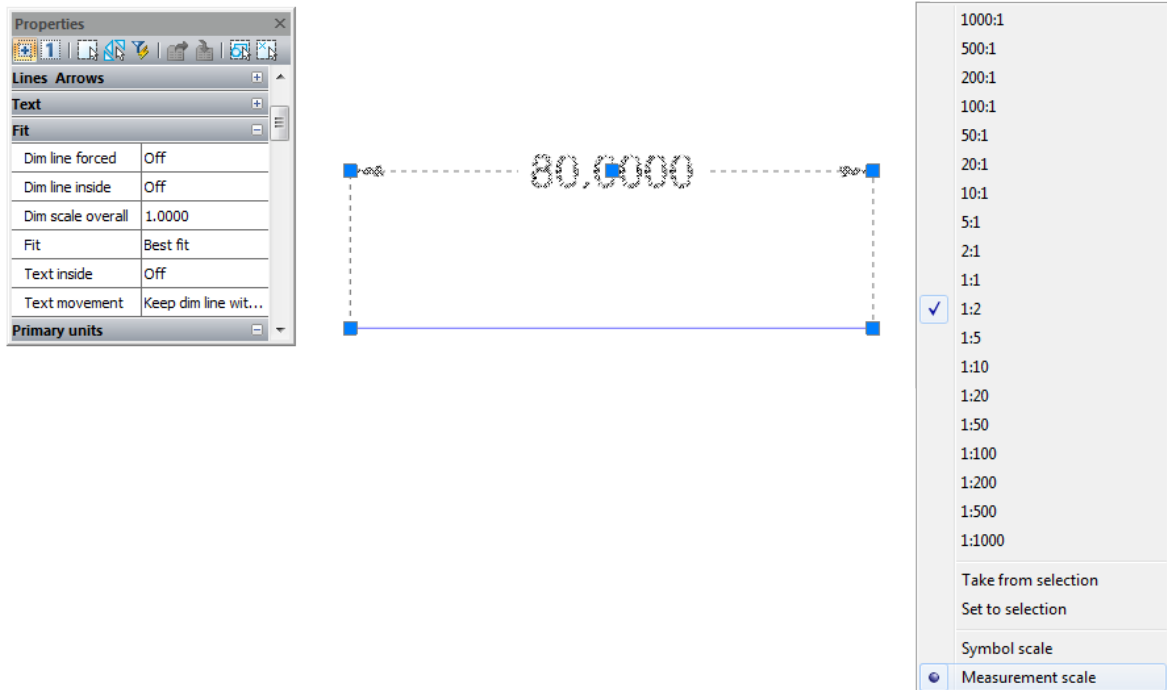

## «Scale» Toolbar



Ribbon: **Manage – Customization – Interface** >  **Toolbars** > **Scale**



Menu: **View - Toolbars – nanoCAD toolbars - Scale**



Current scale can be changed to scale from Scale list in **Scale** toolbar.

### Scale buttons:



**Get Scale** from selected objects. It is necessary to specify the object from which the value for the current scale will be taken.



**Set Scale** to selected objects. It is necessary to specify the object to which the current scale will be applied.

## System Variable Monitor



Ribbon: **Manage – Palettes** >  **System variable**



Menu: **Tools** >  **System variable**



Menu: **View – Toolbars – Functional** >  **System variable**









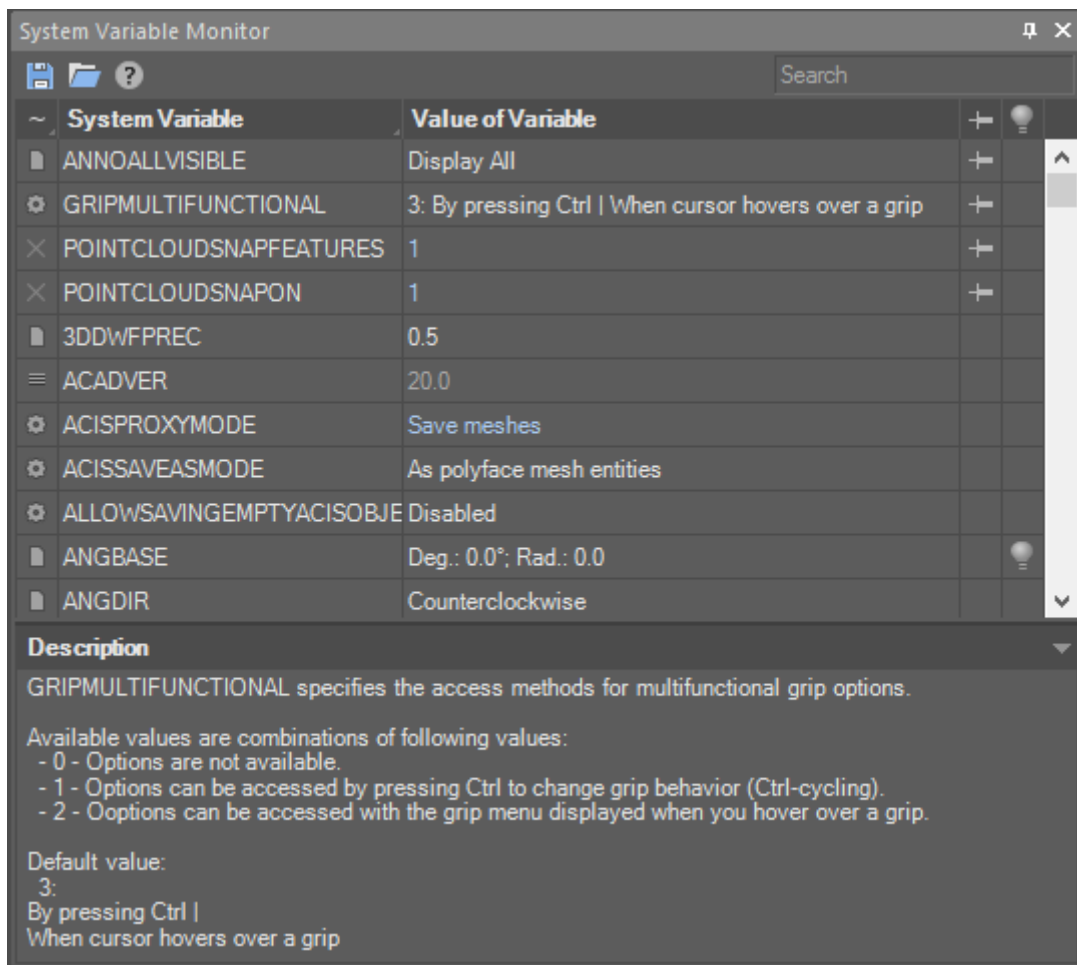





Command line: **SYSVARMONITOR**

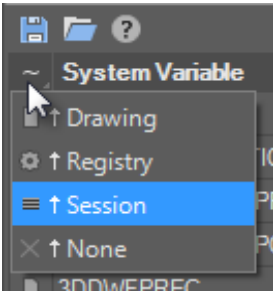
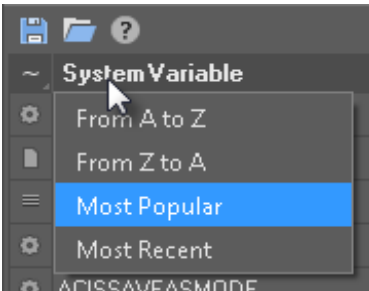

The System variable monitor displays system variables, their brief description and values, allowing you to edit, sort, search them and track changes in real time.



	Saves variables to a file and load from the file. It is possible to save both all and only pinned  variables.
Search	Searches for variables by name.

	<p>Storage location:</p> <ul style="list-style-type: none"> <li> - the variable is stored in the registry. Always retains its value.</li> <li> - the variable is stored in the document. Its value changes only for a specific document.</li> <li> - the value of the variable is saved only for the current session. After closing the program, the value is reset.</li> <li> - no storage place. The value is stored until the document is closed.</li> </ul> <p>Sorting is performed by clicking on the column heading or by selecting an item in the menu, which opens by a long click on the heading.</p> 
<p><b>System Variable</b></p>	<p>The name of the system variable.</p> <p>Sorting is performed by clicking on the column heading or by selecting an item in the menu, which opens by a long click on the heading.</p>  <p>In addition to the direct and reverse alphabetical order, the variables can be sorted by frequency of use (<b>More popular</b>) and time of change (<b>Most recently</b>) during an active session of the program.</p>
<p><b>Value of Variable</b></p>	<p>The value of the system variable, which can be entered or selected from a list of fixed variants. Gray (muted) typeface indicates variables with constant values. If the value of a variable differs from its initial value, it is displayed in blue font. In most cases, the initial value is given in the variable description at the bottom section of the panel.</p>
	<p>Click in this column opposite the variable to fix the variable at the top of the list, regardless of the sorting method. The variable moves to the top of the list, the  icon appears in front of it.</p>
	<p>Click in this column opposite the variable to start tracking the change of the variable. Turned off lightbulb  will appear, meaning that the variable has not yet been changed since the start of its tracking. If the value of the variable is changed (by a command or by a user), the bulb will "light up": .</p>

# COORDINATE SYSTEMS

The position of every drawing point is defined by its coordinates. In the command prompt for a point position you can specify it on the screen or type the coordinates in the command line.

## Specifying Coordinates

Coordinates can be specified in the *Cartesian coordinate system* and *Polar coordinate system*.

*Cartesian and Polar coordinates* can be relative and absolute.

### Cartesian Coordinates

*Cartesian coordinate system* is defined by three perpendicular axes: X, Y and Z.

The origin of the coordinate system is the point of intersection of the three axes and has the coordinates: (0,0,0).

If you work in the plane, the Z coordinate is always 0, you have to specify X and Y. The X value is specified horizontally and Y value vertically. Positive coordinates are set to the right and above the origin, and negative to the left and below.

When working in three dimensions, you have to set the Z coordinates. By default, the Z axis is set perpendicular to the XY plane from the viewpoint of the observer. The positive coordinates are set above the plane and negative below.

For example, the coordinates (30,20) specify the point set 30 units in on the X axis and 20 units in on the Y axis.

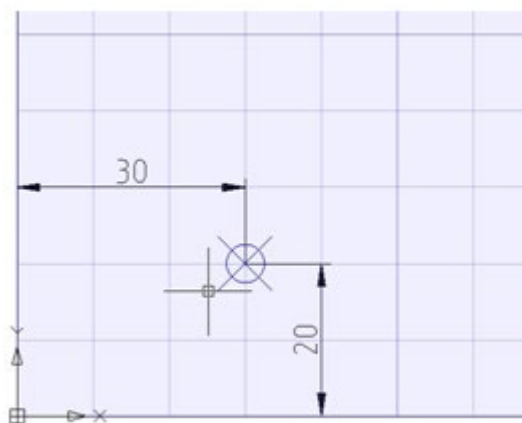

*Absolute coordinates* are specified from the origin of the coordinate system. Absolute are used if the precise X and Y coordinates are known values.

#### Example:

The point with coordinates X=10 and Y=20 is the start and the point with coordinates X=30, Y=40 is the end of the line. To create the line, enter in the command line:

```
Command:      Line
Specify      10,20
first
point:
Specify      30,40
next
point:
```

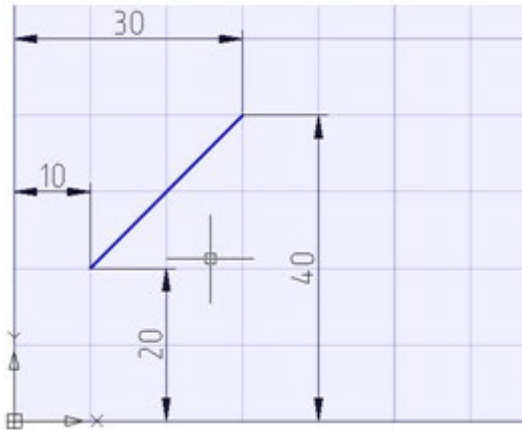

*Relative coordinates* are used when the distance from the previous point is a known value.

To specify relative coordinates, enter the @ symbol before their values. Values specified after the @ symbol are distances along the X and Y axes from the previous point.

To create a line from the previous example using the relative coordinates enter in the command line:

```
Command:      LINE
Specify first point:      10,20
Specify next point:      @20,20
```

## Polar Coordinates

In the Polar coordinate system, the absolute coordinates of a point are set by the distance from the origin and an angle between the polar axis and a line lying through the point and origin. The angle is set in degrees counter clockwise.

For example, the coordinates 40<30 specify a point on the plane, setting the distance as 40 units from the origin and with a 30 degrees angle from the X axis.

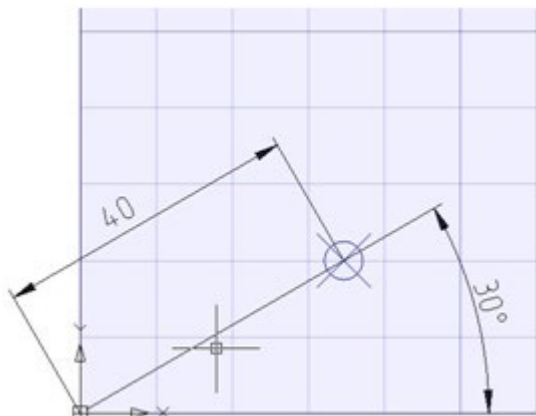

Example: The start point of the line is set as 20 units from the origin and at a 45 degree angle from the X axis; the end point is set as 50 units from the origin and 30 degrees from the X axis. Enter in the command line:

```
Command:      LINE
Specify first point:      20<45
```

```

point:
Specify      50<30
next
point:

```

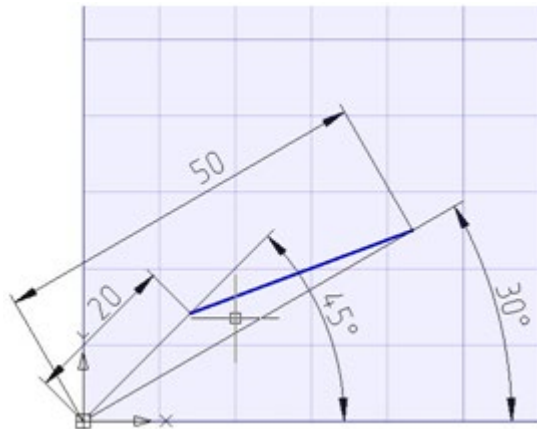

In the **relative polar coordinates** the distance to the point is set not from the origin, but from the previous point. The angle is specified from the polar axis to the line connecting the previous point and the defining point.

The @ symbol is used to specify **relative coordinates**.

### Example:

The start point of a line is set as 20 units from the origin and at a 45 degree angle from the X axis; the end point is set as 40 units from the previous point and 30 degrees from the polar axis. Enter in the command line:

```

Command:      Line
Specify      20<45
first
point:
Specify      @40<30
next
point:

```

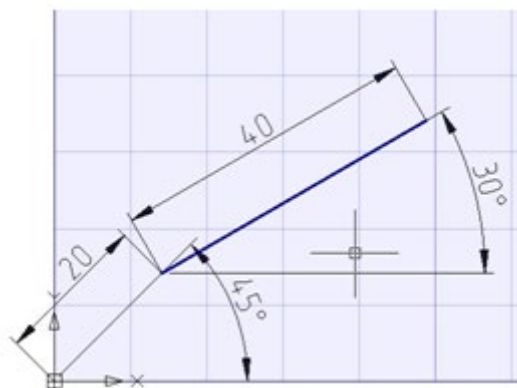

## Specifying Points With “Direction – Distance”

The direct distance is set instead of entering coordinates; it is very useful for quickly entering the lengths of lines.

Using direct distance specifying, move the cursor in the desired direction and enter the length value in the command line at the command prompt: **Specify next point:**. If ortho mode is switched on, it is very useful for drawing perpendicular lines.

This method can be used in all commands, except commands where just a value is needed, for example **Array**, **Divide** etc.

## Coordinate Filters

Coordinate filters are entered in response to a point request and define the axes along which coordinates will be set. You can enter the following filters: **.x**, **.y**, **.z**, **.xy**, **.xz** or **.yz**.

Coordinate filters allow you to input the coordinates of a point for each axis separately, specifying coordinates first along one axis, then along another.

Coordinate filters are useful when the value along one axis is determined by one characteristic point of the object, and along the other axis by another point. When using coordinate filters, it is possible to extract one coordinate value at a time from selected characteristic point of an object by using a snap.

For example, you need to enter the coordinates of a point, located in the center of a drawn rectangular window.

In response to a point request:

Specify point:

1. Enter filter: **.x**

The request will change its appearance. Now not all coordinates are requested, but only the value along the X axis:

Specify point: >> X

2. With the **Midpoint** snap activated, specify the horizontal edge of the window. This will define the coordinate of the point along the X axis.

Now the coordinates for the remaining Y and Z axes are requested:

Specify point: >> YZ

3. We are satisfied with the mode of cleaving coordinates from a point simultaneously along two specified axes. Therefore, it is not necessary to enter any other coordinate filters. With the **Midpoint** snap activated, select the vertical edge of the window. This will define the coordinates of the point along the Z and Y axes.

## User Coordinate System

nanoCAD uses two kind of coordinate systems: *world coordinate system* and *user coordinate system*.

Only one coordinate system is active at any time; it is called *current*.

*World coordinate system* is a base coordinate system and cannot be redefined (X axis is set horizontally, Y axis vertically and Z is perpendicular to XY plane). The main difference of the world coordinate system from the user coordinate system is its rigidity and that it can be the only one (for every model space and layout).

The usage of the *user coordinate system* has almost no restrictions; it can be placed at any point of the space and with any angle to the world coordinate system. UCS can be moved and rotated to specify points on the three dimensional and rotated views. Node points and base directions, defined by the **SNAP**, **GRID** and **ORTHO** modes are rotated with UCS.

## Changing UCS Position

Commands for changing the UCS position set a new coordinate system, the so-called *current coordinate system*.

The *current coordinate system* inherits the parameters of the previous coordinate system, only the required values are changed.

### World Coordinate System



Ribbon: **View – Coordinates** >  **World UCS**



Menu: **Tools – Coordinate system** >  **World UCS**



Toolbar: **UCS** – 

The command sets the parameters of the world coordinate system for the current user coordinate system.

#### To set a World coordinate system quickly:

1. Click in the **UCS name** field on the **Properties** panel.
2. Open the drop-down list and select **World**:

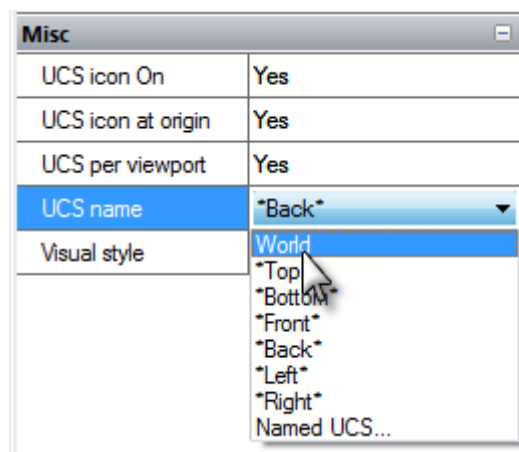

### Changing the UCS Position from the Command Line



Command line: **UCS**

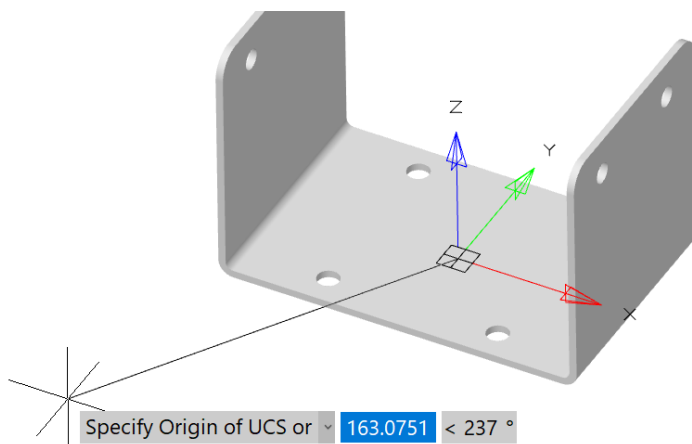

#### Command options:

## Face

Sets the UCS in the plane of the face of a 3D object (**submesh, polyface mesh, polygonal mesh, 3D-solid, parametric solid**).

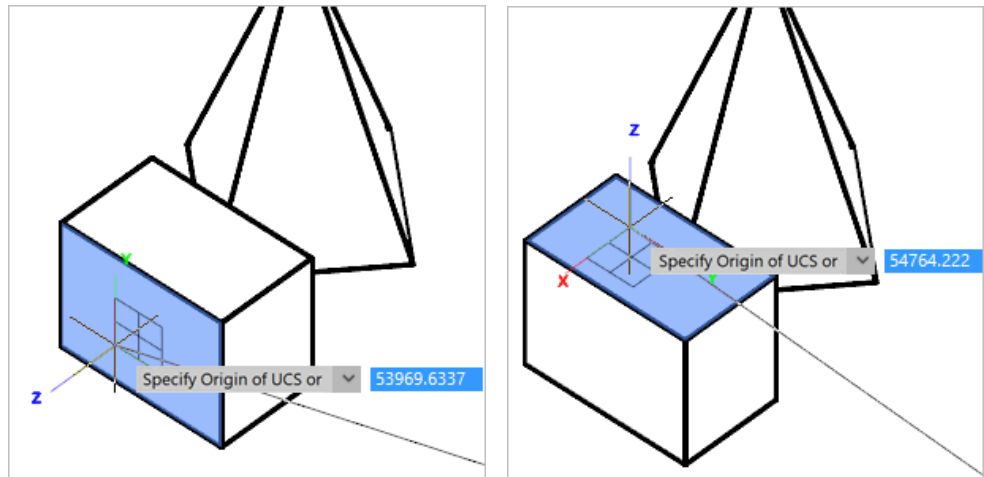

Hover over the desired face to see how the UCS will be aligned. The **Dynamic UCS** (F6) mode must be active. The face is highlighted, and an icon is displayed near the cursor, previewing the direction of the UCS axes.

The origin point will be placed at the center of the cursor in the plane of the selected face.

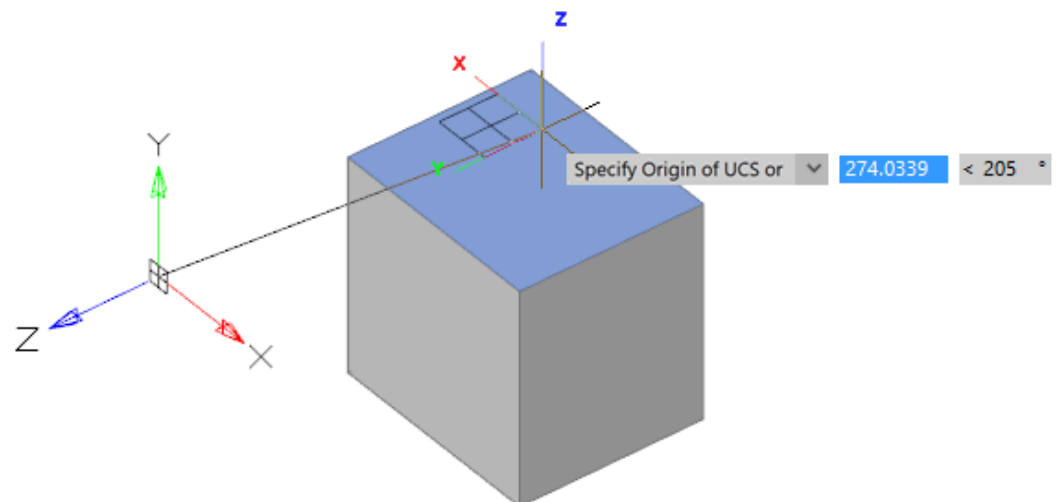

The direction of axes of the new UCS depends on the edge that the cursor crossed when hovering over the face. So the X axis is set parallel to the intersected edge in the direction from the initial vertex of the intersected edge. The Y axis is perpendicular to the X axis and directed towards the inside of the face. The Z axis is so that a right-handed coordinate system is obtained. When you hover the cursor over the same face from the side of another edge, the orientation of the UCS axes also changes.

## Named

Saves and restores frequently used UCS orientations by name.

The option starts the following prompt in the command line:

Enter an option [Restore/Save/Delete/?]

Options: Restore - Replaces the current UCS with a new from the list of named UCS. Save - Saves the current UCS with the specified name.

Delete - Deletes UCS from the list of named UCS. ? - Shows a list of named UCS.



<u>Restore</u>	Replaces the current UCS with one from the list of named UCSs.
<u>Save</u>	Saves the current UCS with a specified name.
<u>Delete</u>	Deletes the UCS from the list of named UCS. When deleting and restoring, named UCS can be selected in the command line: Enter UCS name to delete <none>: or [ <u>?/UCS1/UCS2/UCS</u> ]:
<u>?</u>	Shows the list of named UCS.
<u>Object</u>	Sets the origin and the direction of the UCS axes according to the geometry of the existing object.
<u>View</u>	Specifies a new coordinate system within the XY plane, set perpendicular to the direction of sight and parallel to the viewport's plane. The position of the origin is not changed. The X axis is set horizontally and the Y axis is set vertically.
<u>World</u>	Matches the current UCS to the World coordinate system (restores the World coordinate system).
<u>X/Y/Z</u>	Rotates the current UCS around the selected axis.
<u>ZAxis</u>	Specifies the UCS using the positive direction of the Z axis: the origin is placed at the first specified point; the positive direction of the Z axis is set through the second specified point.

### Command prompts:

Specify origin of UCS or  
[Named/Object/View/World/X/Y/Z/ZAxis]  
<World>:

Select start point of UCS.

Specify point on X-axis or <Accept>:

Specify a point on the positive ray of the X axis.

Specify point on XY plane or  
<Accept>:

Specify a point on the positive ray of the Y axis in the XY plane.

## Aligning UCS to an Object



Ribbon: **View – Coordinates** >  **Object**



Menu: **Tools – Coordinate system** >  **Object**



Toolbar: **UCS** – 



Command line: **SETUCSBYOBJECT**

The command specifies the new position of the coordinate system origin for the current UCS; the direction of the axes is specified according to the geometry of the current object. The extrusion direction of the selected object specifies the positive direction of the Z axis for the new UCS.

Rules to create UCS, aligned to an object:

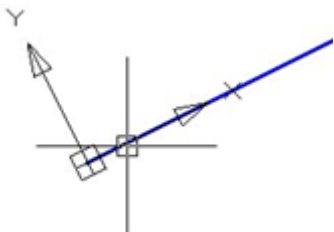
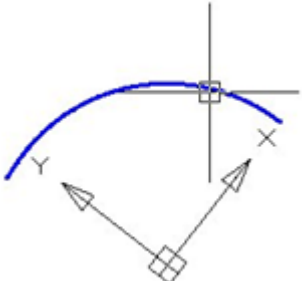
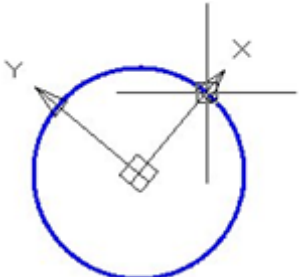
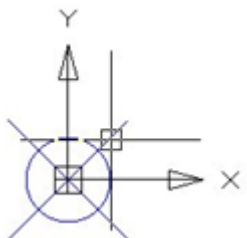
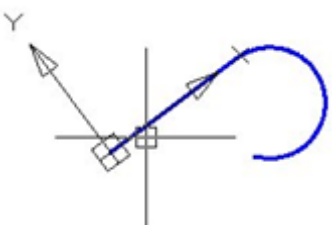
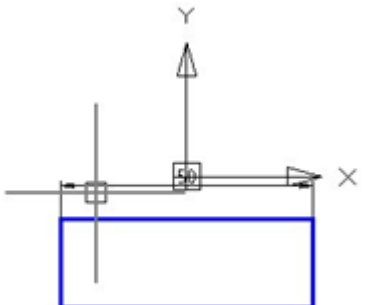

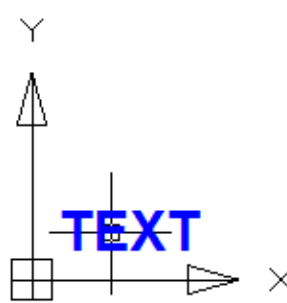



Line		<p>The origin of the new UCS is set at the line end which is closest to the selection point. The X axis is used to place the line in the XZ plane. The Y coordinate of the second end of the line is zero in the new UCS.</p>
Arc		<p>The origin of the new UCS is the center of the arc. The X axis is set at the end of the arc which is closest to the selection point.</p>
Circle		<p>The origin of the new UCS is the center of the circle. The X axis is set at the selection point.</p>
Point		<p>The origin of the new UCS is the selection point.</p>
Polyline		<p>The origin of the new UCS is the start point of the polyline. The X axis is set at the start point and the nearest polyline vertex.</p>
Dimension		<p>The origin of the new UCS is in the middle of the dimension text. The new X axis is set parallel to the X axis of the UCS used to specify the dimension.</p>

Text block insertion, attribute definition		The origin of the new UCS is the insertion point of the object and the direction of the X axis is set by the angle of object rotation around the direction of extrusion. The object used to set the new UCS has a zero-rotation angle in this UCS.
--	---	--

**Command prompt:**







Select object to align                      Select an object.  
UCS:

### Setting UCS by View

-  Ribbon: **View – Coordinates** >  **View**
-  Menu: **Tools – Coordinate system** >  **UCS View**
-  Toolbar: **UCS** – 
-  Command line: **UCSVIEW**

The command sets up a new UCS with XY plane parallel to the screen (view), while maintaining the coordinate origin.

### New Origin for UCS







-  Ribbon: **View – Coordinates** >  **Set UCS by Point**
-  Menu: **Tools – Coordinate system** >  **Point**
-  Toolbar: **UCS** – 
-  Command line: **SETUCSBYPOINT**

The command sets a new origin for the current UCS at the specified point.

**Command prompt:**

Specify Origin of UCS                      Enter the coordinates of UCS origin or specify its position  
<World>:    on the screen.

### New Origin and Rotation Angle for UCS







-  Ribbon: **View – Coordinates** >  **Set UCS by point and angle**
-  Menu: **Tools – Coordinate system** >  **Point and angle**
-  Toolbar: **UCS** – 
-  Command line: **SETUCSBYPOINTANGLE**

The command sets a new origin for the current UCS and the rotation angle of its axes.

**Command prompt:**

Specify origin of UCS [] <World>:	Enter the coordinates for the UCS origin or specify its position on the screen.
Specify point on X axis or <Accept>:	Set the rotation angle on the screen by specifying a point, the positive direction of X axis will pass through, or enter its value in the command line. For example, as follows: 100<30.

## Changing Direction of Z-Axis in UCS







-  Ribbon: **View – Coordinates** >  **UCS by Zaxis**
-  Menu: **Tools – Coordinate System** >  **UCS by Zaxis**
-  Toolbar: **UCS** – 
-  Command line: **UCSZAXIS**

Setting UCS by the positive direction of Z axis: the coordinate origin of UCS moves to the first specified point, the positive direction of Z axis passes through the second specified point

**Command prompts:**

Specify new origin point or [Object] <0,0,0>	Enter the coordinates of UCS origin or indicate its position by cursor.
Specify point positive of Z-axis <Accept>:	Specify point positive of Z-axis.

## Defining a New UCS by 3 Points

-  Ribbon: **View – Coordinates** >  **UCS by 3 Point**
-  Menu: **Tools – Coordinate System** >  **UCS by 3Points**
-  Toolbar: **UCS** – 
-  Command line: **UCS3POINTS**

Determining the orientation of a new user coordinate system by three points.

**Command prompts:**

Specify new origin point <0,0,0>:	Enter the coordinates of UCS origin or indicate its position by cursor.
Specify point on X-axis or <Accept>:	Specify point on positive X-axis.
Specify point on XY plane or <Accept>:	Specify point on positive XY plane.

## Rotating UCS Around X, Y or Z Axes





Ribbon: **View – Coordinates** >   



Menu: **Tools – Coordinate System** >  **UCS by X**,  **UCS by Y**,  **UCS by Z**



Toolbar: **UCS** –   



Command line: **UCSX, UCSY, UCSZ**

Rotating the current user coordinate system around the specified axis.



Rotate UCS around X axis



Rotate UCS around Y axis



Rotate UCS around Z axis

### *To rotate the current UCS around the specified axis:*

1. Select the command to rotate around the desired axis.
2. Specify the rotation angle in the command line or on the screen.

## Dynamic UCS



Status bar:  **Dynamic UCS**



Hotkeys: **F6**



Command line: **UCSDETECTCMD**

When you create an object and move the cursor over a flat segment, the UCS temporarily aligns with it. This makes it possible to immediately draw in the plane of the highlighted face without additional execution of change-UCS commands. This feature is available in the **Dynamic UCS** mode.

In the dynamic UCS mode, UCS changes its orientation when you move cursor over a face of a 3D solid or a flat segment of a point cloud.

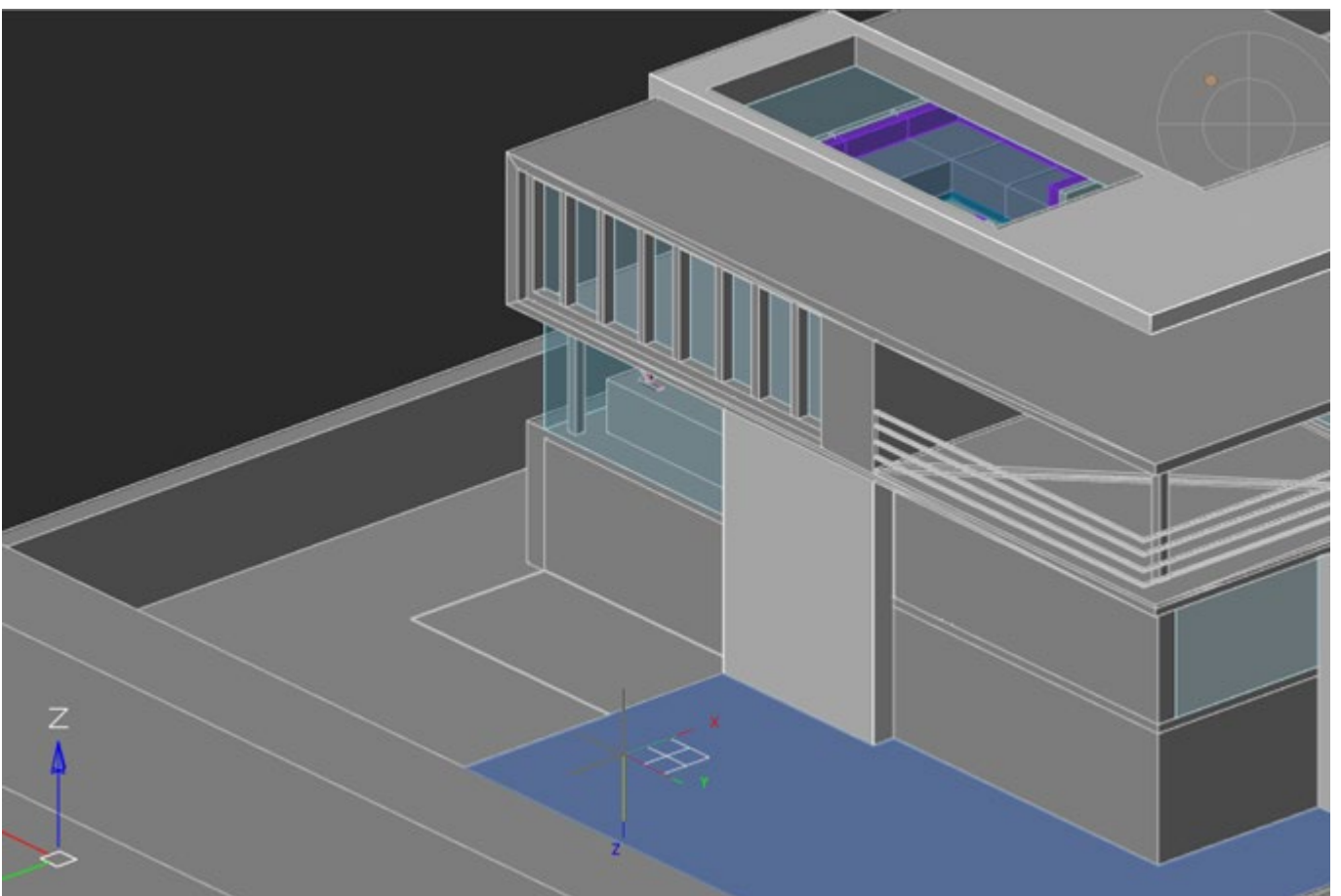
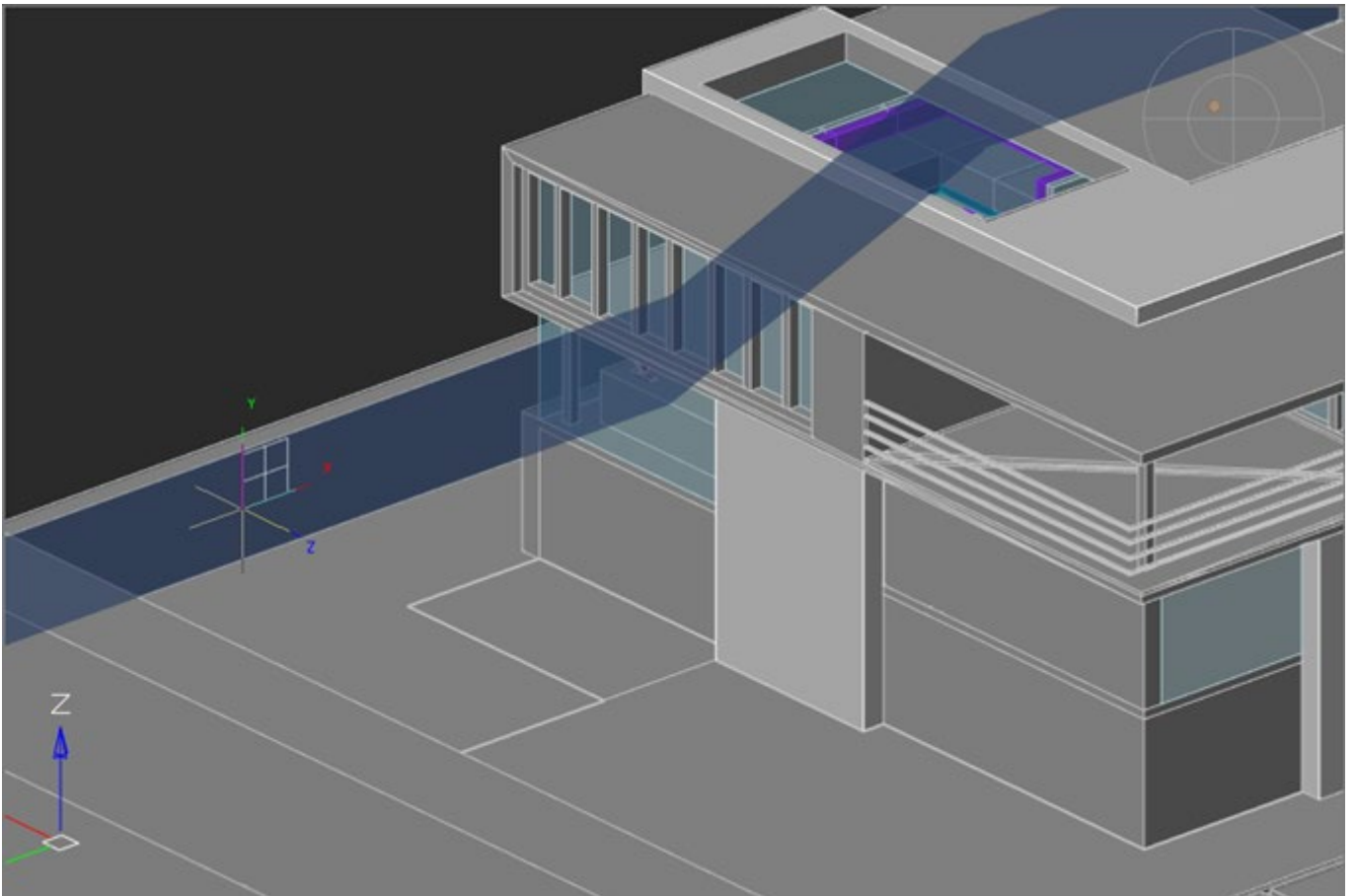

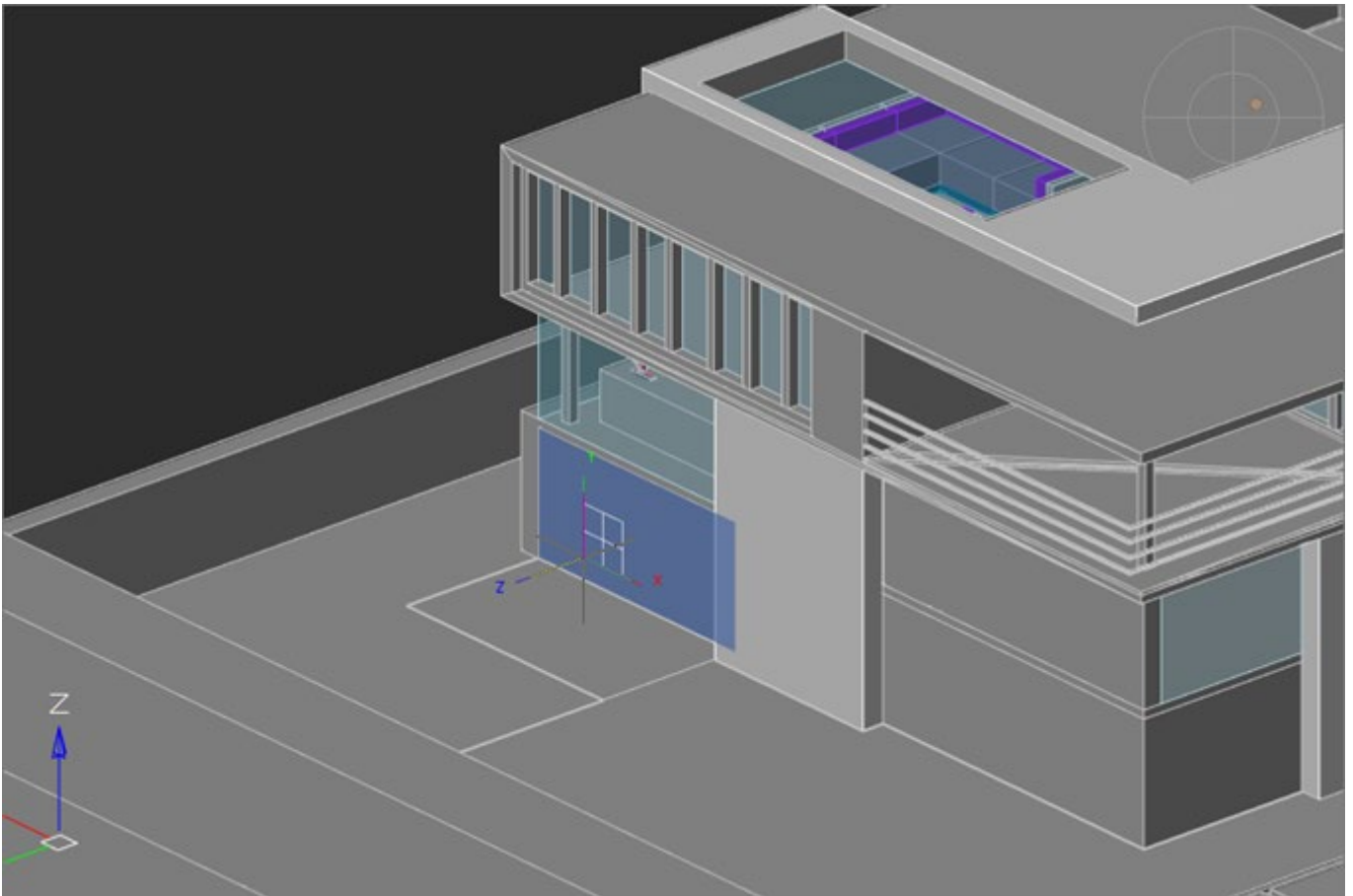

The dynamic UCS works on point clouds with surfaces, previously recognized by the



**Search Planes in Point Clouds** command.

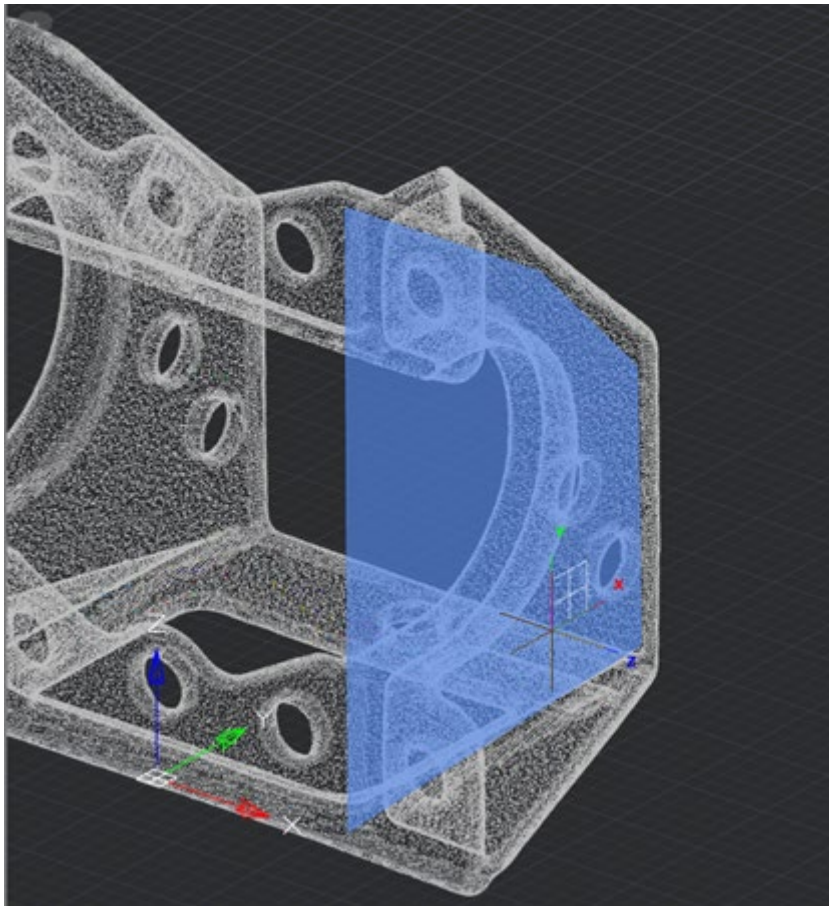

The direction of the UCS axes depends on the edge that the cursor crossed when moving to the face.

So, the X axis is set parallel to the crossed edge in the direction from the initial vertex of the crossed edge. The Y axis perpendicular to the X axis and is directed toward the inner part of the face. Z axis is set so that the right coordinate system is obtained.

When you move cursor toward the same face through another edge, the orientation of the UCS axes also changes.

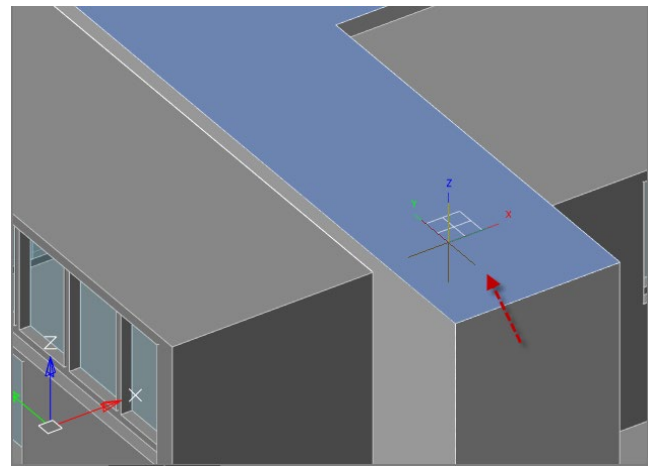
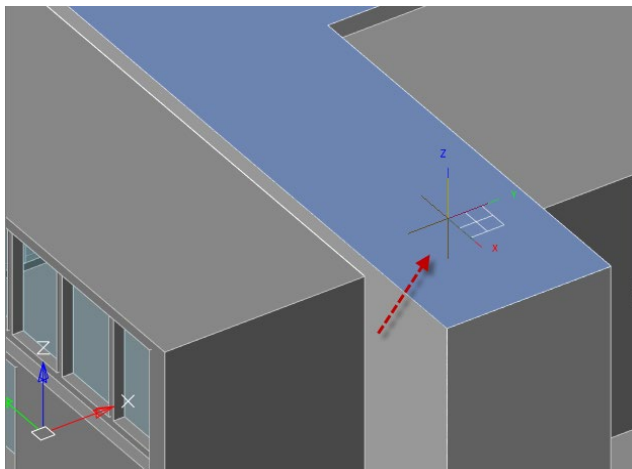
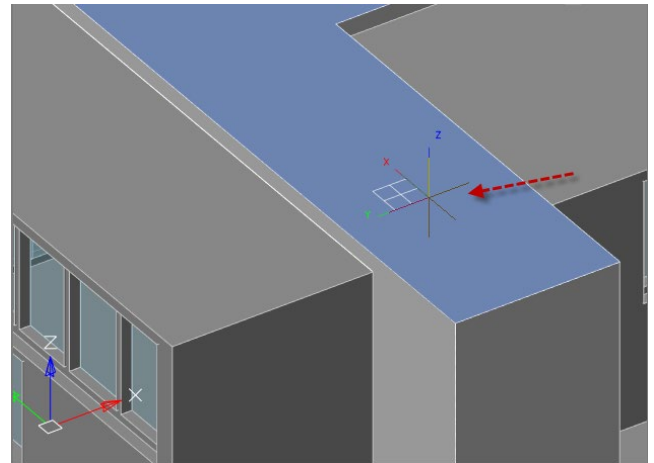

At the first mouse click, the UCS is fixed and the first vertex of the created object is set. Then you can continue to draw in the selected plane. Upon exiting the object creation command, the UCS is reset to its original orientation.

To change the UCS again when specifying another vertex while the construction command is running, you need to hold down the **CTRL**+**↻** key combination.

You can change the UCS when specifying each vertex without using keyboard shortcuts. To do this, assign the value 1 to the UCSDETECTMODE variable (default = 0).



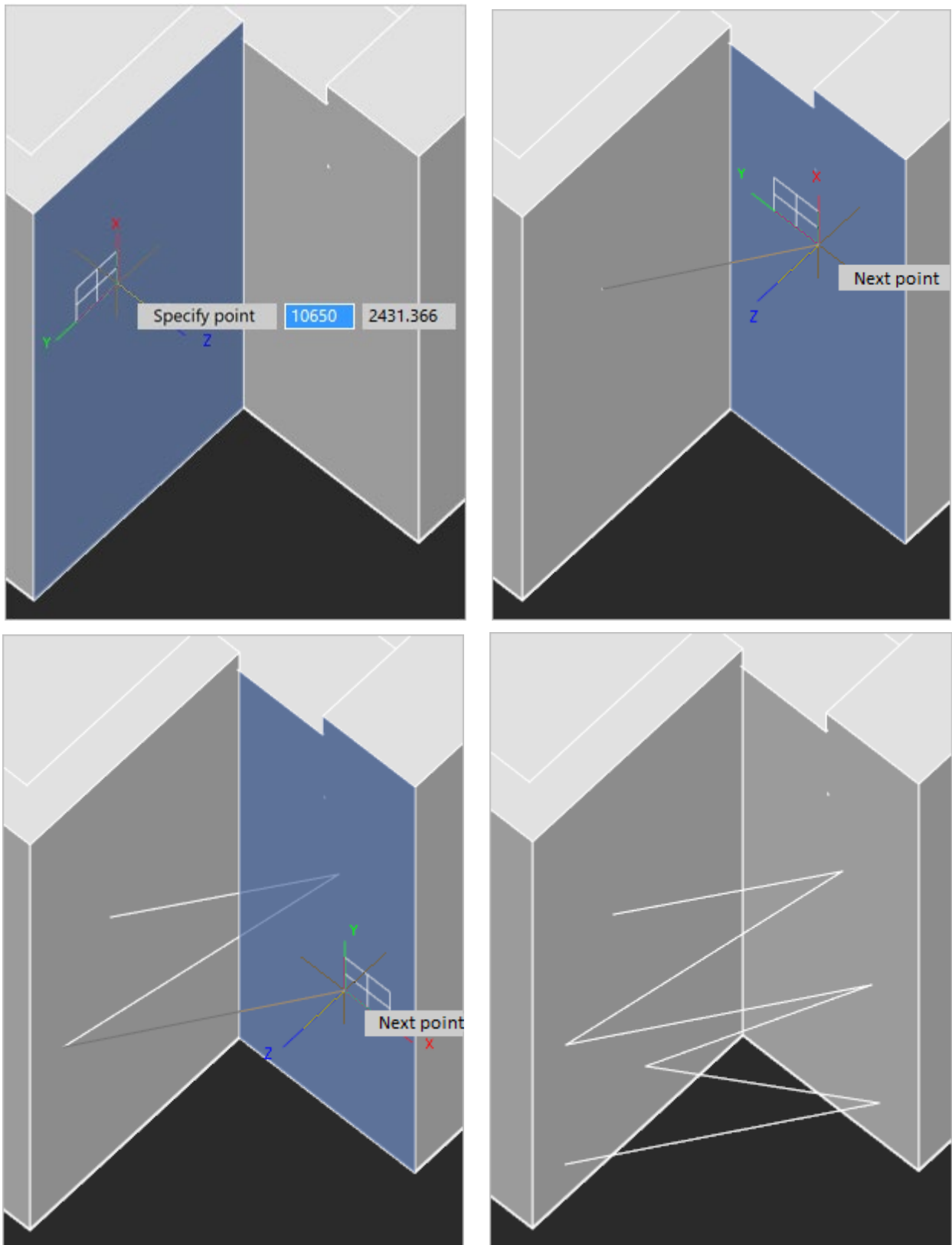

Upon exiting the command to create a vector object, the UCS is reset to its original position.

## UCS Icon

-  Ribbon: **View – Viewport Tools >**  **UCS icon**
-  Menu: **View – Display > UCS icon**



Command line: **UCSICON**

Manages the visibility and position of the UCS icon.

There are **On**, **Off** and **Origin** commands available in the **View – Display > UCS icon**.

To manage the visibility of the UCS icon use the **Properties** panel:

Misc	
UCS icon On	Yes
UCS icon at origin	No
UCS per viewport	Yes
UCS name	Unnamed
Visual style	Shaded

The full list of options available to manage the UCS icon is available in the command line.

### Command options:

ON Shows the UCS icon.

OFF Hides the UCS icon.

All Parameters of visibility for all viewports. If this option is not used, the parameters of the UCS icon are specified only for the current viewport.

The option starts the following prompt in the command line:

Entry an option or [ON/OFF/Noorigin/Origin/] <ON>:

If the option is not used, parameters of UCS icon are set only for the current viewport.

Noorigin Shows the UCS icon in the left corner of the screen regardless of UCS origin.

Origin Shows the UCS icon at the origin (0,0,0) of the current UCS. If the origin of the UCS is outside the visible part of a drawing, the icon is shown in the left corner of the screen.

### Command prompt:

Entry an option or [On/Off/All/Noorigin/Origin]  
<"On">:

Select the required option.

## Named UCS



Ribbon: **View – Coordinates >**  **Named UCS...**



Menu: **Tools –**  **Named UCS...**



Toolbar: **UCS –** 



Command line: **UCSMAN, UC**

The command opens the **UCS** dialog box, where you can select from the specified UCS, the parameters and UCS icon modes for viewports.

The **UCS** dialog box can be opened from the **Properties** panel:

## Named UCS Tab

This tab contains the list of coordinate systems specified in the current drawing.

If the UCS is not saved or named, it is shown as *Unnamed* in the list.

The current UCS is marked with → sign.

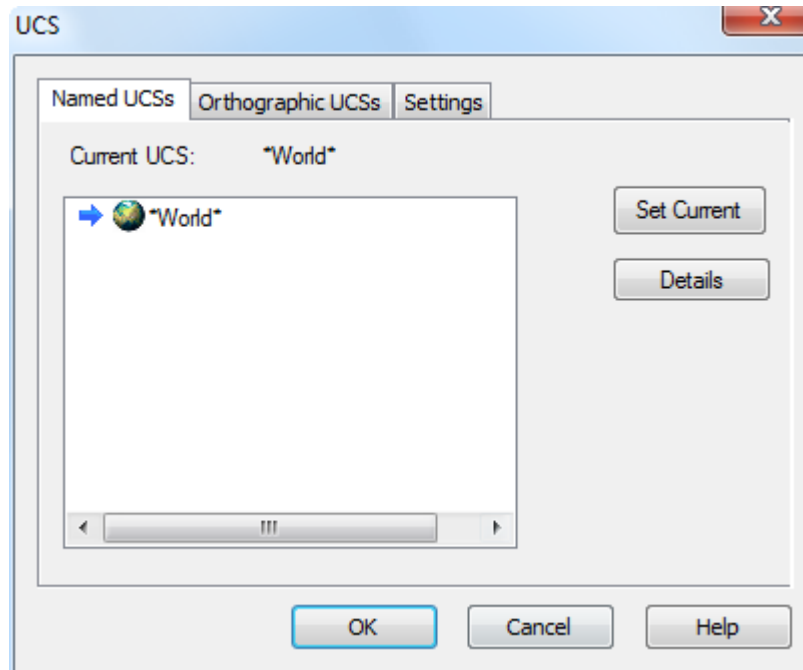

### To set a UCS as current:

1. Select the UCS from the list.
2. Select the **Set Current** button.

You can set the UCS as current by double clicking on the UCS name or select **Set Current** from the context menu:

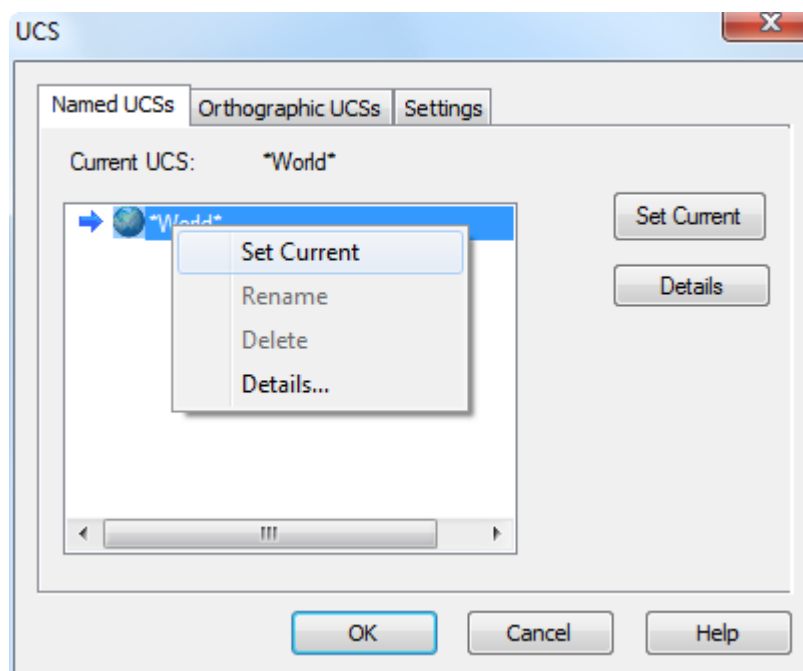

The sign of the set coordinate system is displayed in the graphic area of the drawing, which allows you to control the choice with a variety of named UCSs.

The **Details** button (or command from the context menu) opens the **UCS Details** dialog box with information about the coordinates of the selected UCS:

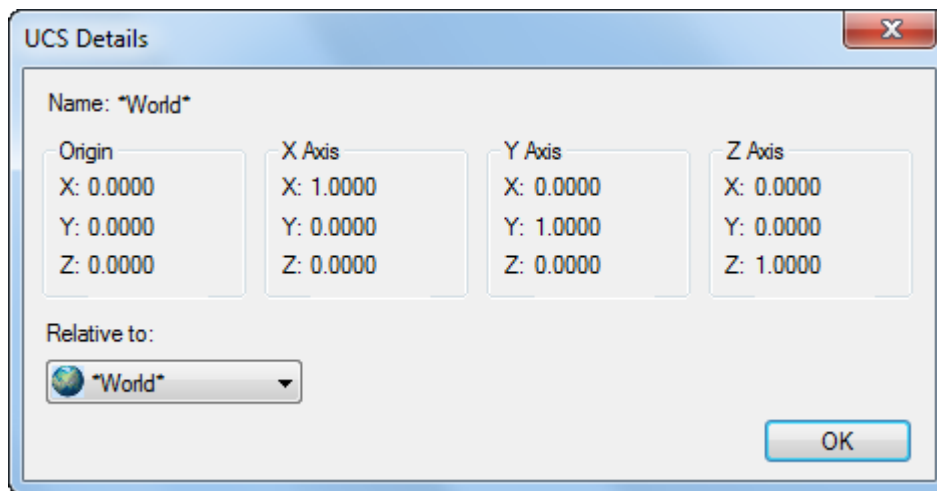

#### *To delete a UCS:*

1. Select the UCS from the list,
2. Open the context menu,
3. Select **Delete**.

#### *To rename a UCS:*

1. Select the UCS from the list,
2. Open the context menu,
3. Select **Rename**,
4. Enter the new name.

#### *To implement changes*

1. Click the **OK** button in the **UCS** dialog.

## **Orthographic UCS Tab**

This tab contains six orthogonal coordinate systems which can be set for a UCS selected in the **Relative to** drop-down list. All named UCS existing in the current drawing are shown in the **Relative to** drop-down list.

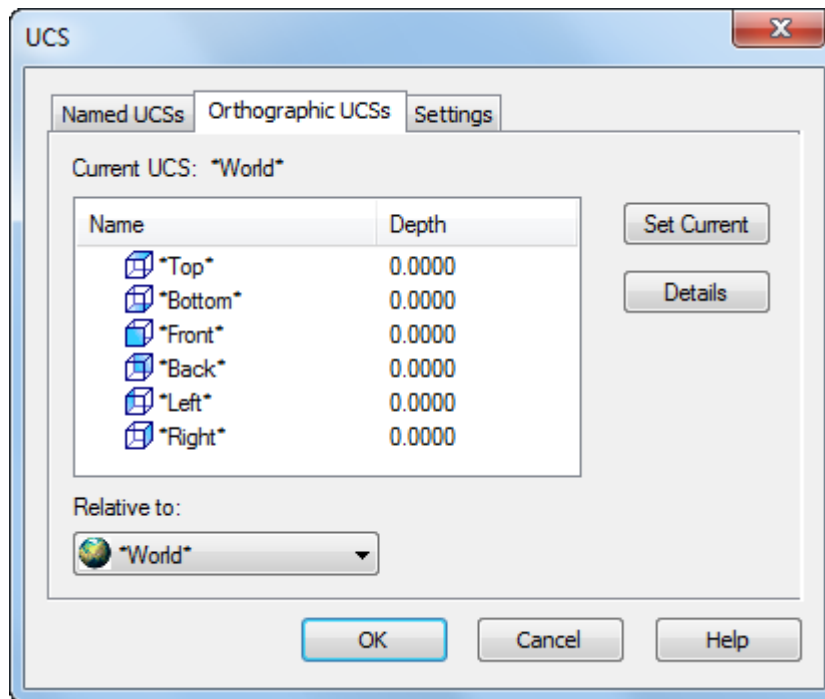

**To set an orthogonal UCS:**

1. Select the UCS from the list,
2. Select the **Set Current** button.

You can set an orthogonal UCS by double clicking on the UCS name or select **Set Current** from the context menu:

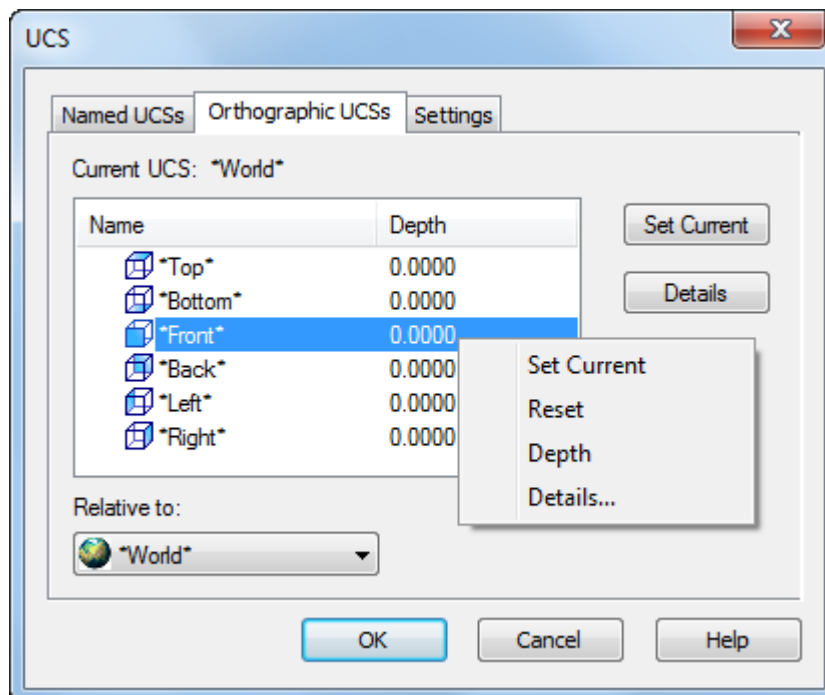

**Options of the context menu:**

- Set Current** Sets the orthogonal UCS as current one.
- Reset** Restores the origin of the selected orthogonal coordinate system (the origin has (0,0,0) coordinates of the base coordinate system).
- Depth** Sets the direction between the XY plane of the orthogonal UCS and the parallel

plane, set through the origin of the base coordinate system.

The parallel plane can coincide with XY, YZ or XZ planes of the base coordinate system.

**Details** Opens the **UCS Details** dialog box with information about the coordinates of the selected orthogonal UCS.

**To set an orthogonal UCS:**

1. Click in the **UCS name** field on the **Properties** panel.
2. Open the drop-down list and select appropriate orthogonal UCS:

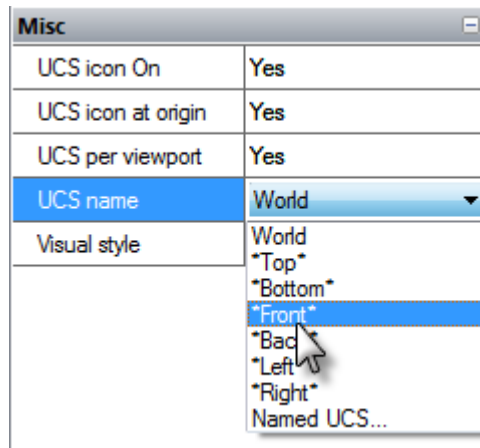

## Settings Tab

The tab is used to show and change the UCS icon modes and the UCS modes saved with the viewport:

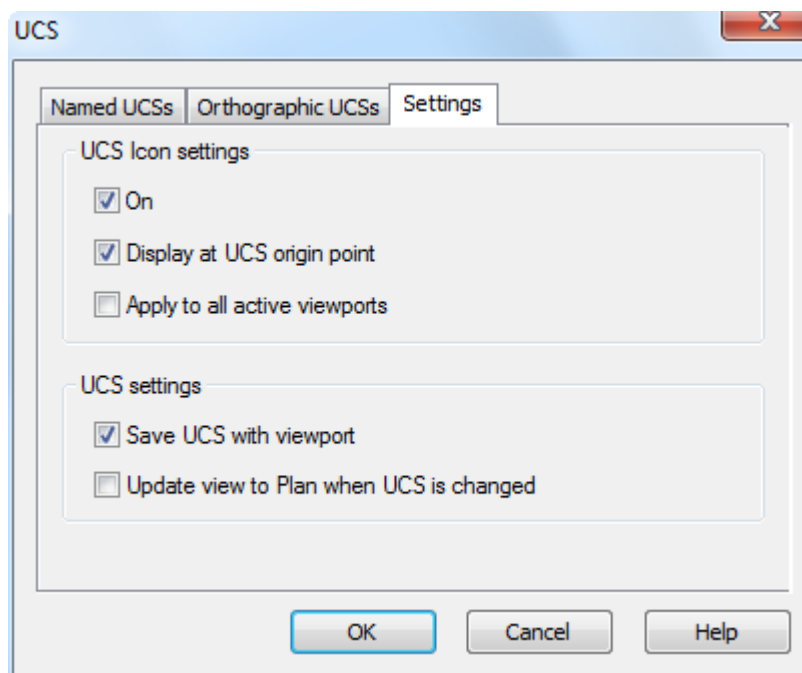

**Parameters:**

*UCS icon setting*

**On** Displays the UCS icon in the current viewport.

**Display** Displays the UCS icon in the current viewport at the origin. If the UCS

**at UCS origin point** origin is outside the viewport and the parameter is switched off, the UCS icon is specified in the left corner of the viewport.

**Apply for all active viewports** Applies the UCS icon modes to all the active viewports of the current drawing.

*UCS settings*

**Save UCS with viewport** Saves the UCS mode with the viewport. If the parameter is switched off, the UCS of the current viewport is used for the specified viewport.

**Update view to Plan when UCS is changed** Restores the view in plan when the coordinate system is changed in the current viewport.

## UCS for Viewports

Different model views can be shown for different viewports. For example, a configuration of three viewports can have the top view in one viewport, the front view in another and the right side view in the third viewport. You can set and save the UCS for every viewport.

If the **Yes** parameter is set in the **UCS per viewport** field on the **Properties** panel, the UCS of the viewport is saved before switching to another viewport. When you switch back to the viewport, the saved UCS restores.

If the **No** parameter is set, the UCS of the viewport always coincides with the UCS of the current active viewport.

Manage saving of the UCS for every viewport on the **Properties** panel:

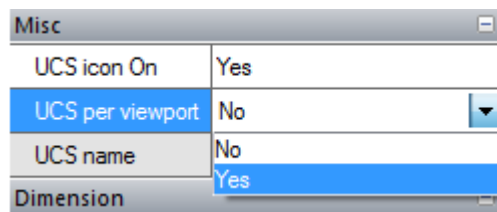

## PRECISION TOOLS

nanoCAD, as with other CAD systems, allows precise geometric creations (up to 14 decimals).

Using precision tools allows:

- quick implementations during the project,
- elimination of errors and inaccuracies in the dimensioning,
- elimination of errors in the measurements of angles, length and distances, which were not dimensioned in the drawing,
- avoiding problems occurring with hatch, due to open contour,
- reducing time spent on the control programs for NC machines (because it is not necessary to edit inaccurate geometry of the parts) etc.

nanoCAD provides precise geometric creations in two ways:

- precise coordinates of object points and
- using precision modes.

Precision modes allow:

- place points on the rectangular grid ([SNAP, GRID modes](#));
- use object snaps to snap to characteristic points on the vector and raster objects, for example to the endpoints of a line or to circle center ([OSNAP mode](#));
- the use of tracking lines to place a created object in relation to other objects ([OTRACK mode](#));
- snap to specified angles and define distances using polar tracking ([POLAR mode](#));
- create and replace objects parallel or perpendicular to coordinate axes ([ORTHO mode](#)).

### Precision Modes

Precise tools are controlled in the context menu by the buttons and in the **Drafting Settings** dialog box (**Tools> Drafting settings**).

Buttons to switch between precise modes are in the status bar.

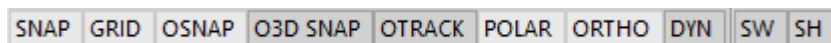

The orange color of a button shows that the mode is switched on.

All or several modes can be switched on at once.

Three ways to switch on/off the modes:

- Click on the button.
- From the context menu of the button select **On** or **Off**.
- In the **Drafting Settings** dialog box (**Tools> Drafting settings**) select or deselect the check boxes: **Snap on** (**F9**), **Grid on** (**F7**), **Polar Tracking on** (**F10**), **Object Snap on** (**F3**), **Object Snap Tracking on** (**F11**), **Object Snap 3D On** (**F4**).

*To open the context menu with the commands to control modes:*

1. Place the cursor in the status bar,
2. Press the right button,
3. Select/deselect the required mode.



**NOTE:** To cancel the context menu of the **OSNAP** select the **Exit Menu** command (other context menus are closed after the parameter is selected).

The **Drafting Settings** dialog box consists of three tabs:

- [Snap and Grid](#),
- [Polar Tracking](#),
- [Object Snap](#)
- [Object snap 3D](#)

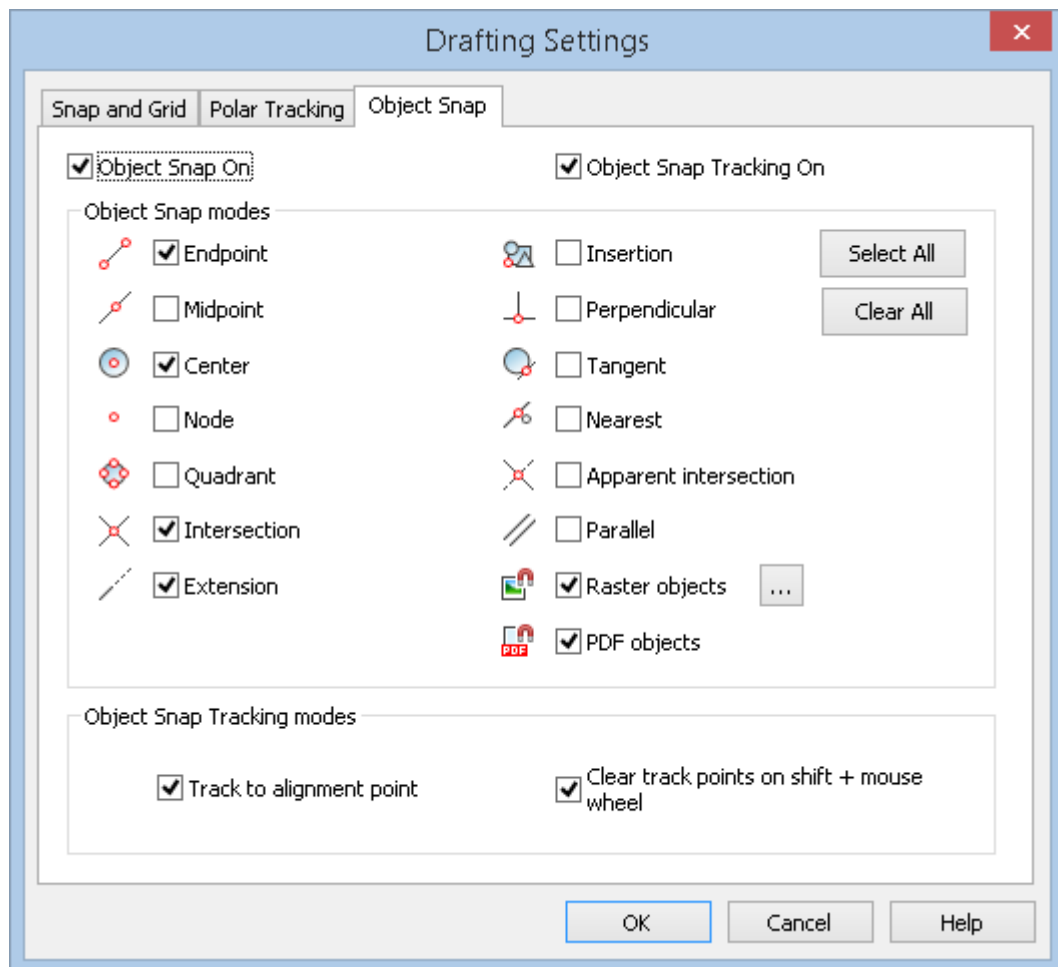

## Snap and Grid Mode



Menu: **Tools** –  **Drafting settings...** > **Snap and Grid** tab



Status bar: **SNAP** and **GRID**



Hotkeys: **F9** and **F7**



Command line: **DDRMODES**, **DSETTINGS**, **SE**

*Grid* is an ordered sequence of points, which with **SNAP** mode allows specifying restrictions of the cursor movement to define accurate coordinates. You can switch the grid on/off at any time when you are working with a drawing. Changing grid spacing does not affect any drawing objects.

When the grid is on, the positive directions of the abscissa and ordinate axes are displayed in color, which additionally helps navigate the editing plane. The colored rays are directed from the origin of coordinates. Red is assigned to the X-axis, green is assigned to the Y-axis.

Grid is not printable.

If **SNAP** mode is switched on, the cursor jumps from node to node with the specified snap spacing. Snap spacing and grid spacing can be different but very often their values are the same. Grid can have high spacing and snap spacing can be small to give a user the capability to specify points of high precision. For example, you can set grid spacing to 10 units, and snap spacing to 1 unit. Grid and snap spacing can be different along the X and Y axes.

*Major line* – additional lines are also highlighted:

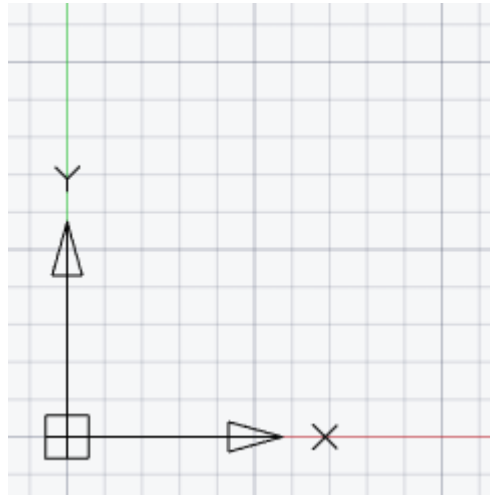

*Adaptive grid* – grid display depends on the drawing scale. When zooming in, additional grid lines appear; when zooming out, they disappear. The frequency of these lines is determined by the frequency of the main grid lines.

A grid showing drawing *limits*, allows visualization of the drawing dimensions to place base elements on the initial stages.

The parameters of the **SNAP** and **GRID** modes are specified in the **Snap and Grid** tab of the **Drafting settings** dialog box or in the context menus.

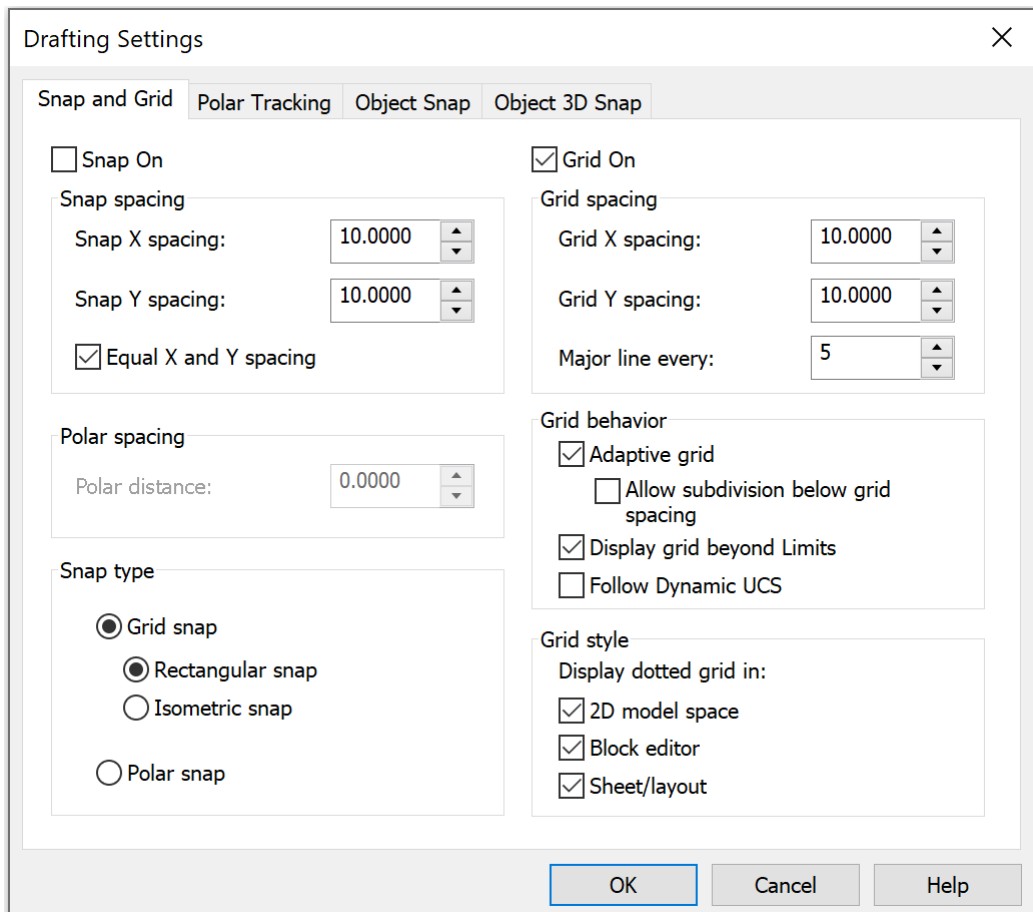

### Tab parameters:

**Snap On (F9)** Switches snap mode on/off.  
Grid snap mode can also be turned on/off by the **SNAP** button in the status bar, **F9** key or SNAPMODE system variable..

### Snap spacing

**Snap X spacing:** Specifies the X spacing.  
The value should be a positive real number. (SNAPUNIT system variable).

**Snap Y spacing:** Specifies the Y spacing.  
The value should be a positive real number. (SNAPUNIT system variable).

**Equal X and Y spacing** Sets equal spacing between X and Y.  
Snap spacing may differ from grid spacing.

### Polar snap

**spacing:** Specifies a snap when setting the polar snap mode (POLARDIST system variable). When set to zero, a polar snap spacing is equal to snap spacing by X.  
A polar snap only works when polar and/or object tracking is enabled..

### Snap type

#### Grid snap

Specifies a grid snap for the cursor movement to horizontal and vertical grid points (SNAPTYPE system variable).

#### Rectangular

Specifies the standard mode for rectangular snap. In case of grid and rectangular snap type, the cursor moves along the rectangular structure nodes. (SNAPSTYL system variable).

#### Isometric

Specifies the mode of isometric snap and activates the [isometric drafting mode](#). In case of grid and isometric snap type, the cursor moves along the isometric grid nodes. (SNAPSTYL system variable).

#### Polar

Specifies the polar snap. With polar snap and enabled polar tracking, the cursor can move along imaginary lines drawn from the tracking base point at the angles specified on the **Tracking** tab. (SNAPTYPE system variable).

To use the polar snap in the isometric drafting mode, you should first set the isometric snap, and then switch to polar snap:

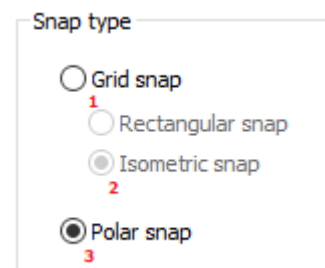

### Grid:

#### Grid on (F7)

Enables/Disables the display of grid on the screen.

The grid mode can also be turned on/off using  button in the status bar, **F7** key or GRIDMODE system variable.

### Grid spacing

#### Snap X spacing:

Specifies the distance between grip nodes by X axis. When set to zero, a grip spacing is equal to a grip snap (GRIDUNIT system variable).

#### Snap Y spacing:

Specifies the distance between grip nodes by Y axis. When set to zero, a grip spacing is equal to a grip snap (GRIDUNIT system variable).

#### Major line every:

Specifies the number of grip nodes through which the main (thickened) grip lines are displayed (GRIDMAJOR system variable).

### Grid behavior

**Adaptive** Switches adaptive grid mode on/off.

## grid

### Allow subdivision below grid spacing

Switches division of the grid spacing on/off.

### Display grid beyond limits

Switches display of the grid beyond specified limits on/off.

### Follow Dynamic UCS

Sets the grid plane in accordance with XY plane of dynamic UCS (GRIDDISPLAY system variable).

#### *Grid style. Dotted grid display area:*

#### **2D model space**

Enables/disables display of the grid as dots in 2D model space (system variable GRIDSTYLE = 1).

#### **Block editor**

Enables/disables display of the grid as dots in the block editor (system variable GRIDSTYLE = 2).

#### **Sheet/layout**

Enables/disables display of the grid as dots in layouts and paper space layouts (system variable GRIDSTYLE = 4).

Default system variable GRIDSTYLE = 0 - Grid is displayed as lines in model space, block editor, layouts and paper space sheet sets.

The context menu of the **SNAP** button:

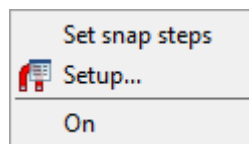

#### *Parameters:*

### Set snap steps

Specifies the X and Y spacings in the command line (SNAPUNIT variable).

### Setup...

Opens the **Drafting settings** dialog box.

### On

Switches snap mode on/off.

The context menu of the **GRID** button:

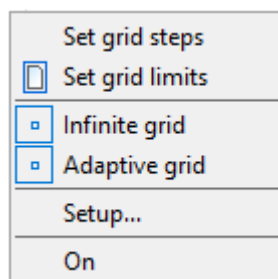

#### *Parameters:*

### Set grid steps

Specifies the X and Y spacing in the command line.

<b>Set grid limits</b>	Specifies the limits of the grid display.
<b>Infinite grid</b>	Switches off restrictions for the grid display.
<b>Adaptive grid</b>	Switches adaptive grid mode on/off.
<b>Setup...</b>	Opens the <b>Drafting settings</b> dialog box.
<b>On</b>	Switches display of the grid on/off.

## Controlling Grid Options from the Command Line



Command line: **TGRID**

The command specifies the grid options.

### Command prompts:

Specify grid spacing(X) or  
 [ON/OFF/Snap/Major/  
 aDaptive/Limits/Follow/Aspect]  
 <10.0000>

Specifies the grid spacing.

When the spacing value is given with adding **x** symbol (Latin), the grid spacing will have the value equal to grid interval multiplied by the entered grid spacing.

### Command options:

<u>ON</u>	Turns on display of the grid with preset spacing value.
<u>OFF</u>	Turns of the grid display.
<u>Snap</u>	Turns on the cursor snap to the grid.
<u>Major</u>	Sets the number of cells in the grid.
<u>aDaptive</u>	Turns on/off the gird adaptive mode. Impacts on the grid density when an image of the screen is zoomed in/out.
<u>Limits</u>	When the option is disabled, the grid is displayed throughout the entire drawing space. If the option is enabled, the grid is displayed on the drawing area limited by the <a href="#">Drawing limits</a> command (LIMITS).
<u>Follow</u>	Turns on/off the dynamic UCS.
<u>Aspect</u>	Sets the grid spacing for X and Y axes. In the <b>Isometric</b> mode this option is disabled.

## Drawing Limits



Menu: **Format – Drawing limits**



Status bar: Context menu of **GRID** – **Set grid limits**



Command line: **LIMITS**

The command sets the limits for the current drawing in Model Space and in Paper Space.

Drawing limits are specified by the coordinates of two opposite corners of the rectangular area – bottom left corner and top right corner.

**Command prompts:**

Specify lower left corner  
<0.0000,0.0000>:

Specify coordinates of lower left corner or pick a point on the screen.

Specify upper right corner  
<841.0000,594.0000>:

Specify coordinates of upper right corner or pick a point on the screen.

## Polar Tracking Mode



Menu: **Tools** –  **Drafting settings...** > **Polar tracking tab**



Status bar: the **POLAR** button



Context menu of the **POLAR** button: **On/Off**



Hotkeys: **F10**



Command line: **DDRMODES, DSETTINGS, SE**

Polar tracking mode helps to specify a point, set at a specified distance and angle from the last selected point. The dotted tracking line with a tooltip shows the distance from the last specified point and current angle value.

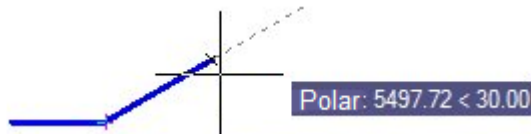

Using polar tracking mode, you can create geometric creations with any specified interval. For example, if an angle of 30 was selected, tracking lines will be displayed when the direction from this point to the cursor's pick box is a multiple 30° (e.g. 60°, 90°, 120° and so on).

Specify the increment of the polar angle in the **Polar tracking** tab of the **Drafting Setting** dialog box or from the context menu of the **POLAR** button.

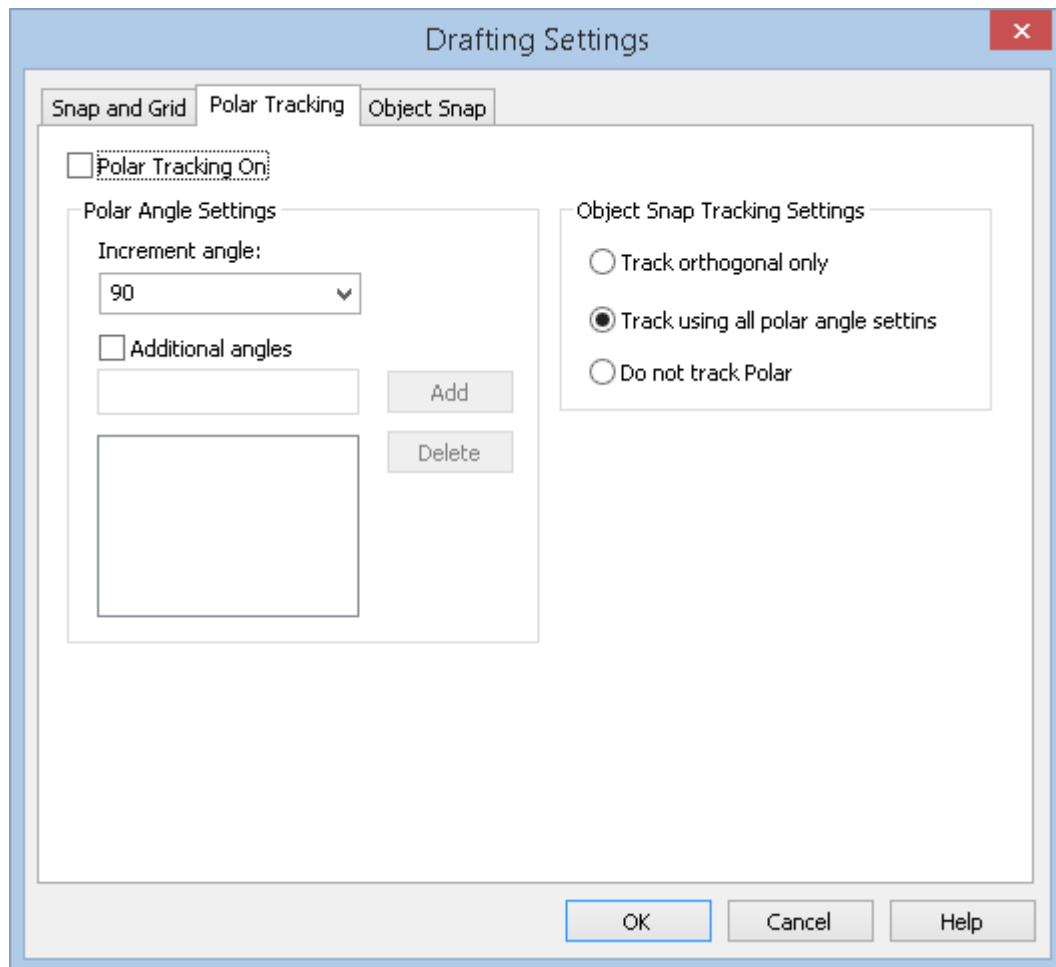

### Parameters:

**Polar tracking on (F10)** Switches polar tracking mode on/off.

### Polar Angle Settings

**Increment angle:** Sets the angle step (increment) used to generate polar tracking lines (POLARANG system variable). For example, if an angle step of 30° is selected, then tracking lines will be displayed at 30°, 60°, 90°, 120°, and so on.

The drop-down list shows commonly used angles: 90°, 45°, 30°, 22.5°, 18°, 15°, 10°, 5°.

The step can also be set by anyone using the keyboard. The entered custom angle step when closing the dialog is automatically set to current. When you set the current step from the list, the custom angle is automatically deleted.

**Additional angles** Enables/Disables the use of additional angles that do not obey pitch rules (system variable POLARMODE = 4).

Additional angles are specified as an absolute value, not as an increment (system variable POLARADDANG).

Using the **Add** and **Delete** buttons you can edit the number of additional corners (maximum 10)

### Object Snap Tracking Settings

**Track orthogonal only** In **OSNAP** mode tracking lines are only drawn horizontally and vertically.



**Track using all polar angle settings**

Switches on the mode for applying the parameters of polar tracking to object tracking. In this mode the cursor is moved from the point of object snap using aligning angles.

**Do not track Polar**

Switches off the polar angles tracking mode.

*Object snap modes*

**Track to alignment point**

Enables/Disables the mode of displaying tracking lines to feature points of the object.

**Clear track points on Shift+mouse wheel**

Enables/Disables the mode of erasing the snap point marker on the tracking line using the **SHIFT** key and the mouse wheel. When the mode is enabled, markers can only be erased using the "shift + mouse wheel" combination. When the mode is disabled, the markers are also erased when zooming/panning.

Object tracking control is discussed in the **Object tracking mode** section.

Format, accuracy, base angle and reference direction for angles are set in the **Drawing Units** dialog box:

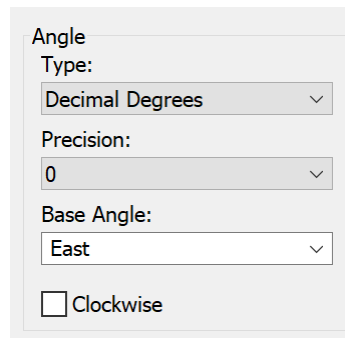

*To set the angles of polar snap lines:*

On the **Snap** tab of the **Drafting Settings** dialog, enable the polar snap mode by checking the **Polar Snap On** box (**F10**).

In the **Increment Angle** field: select a standard value from the drop-down list or enter a custom increment value from the keyboard. When entering multiple angles, the last one entered is saved.

If you need to specify additional angles of the polar snap lines, check the **Additional angles** box. Enter the angle value in the field. Click the **Add** button. Enter up to 10 values. To delete an additional corner, select the corner in the section window and click the **Delete** button.

Click **OK**.

You can also set the angles of polar snap lines and view the current increment angles in the context menu of the **POLAR** button:

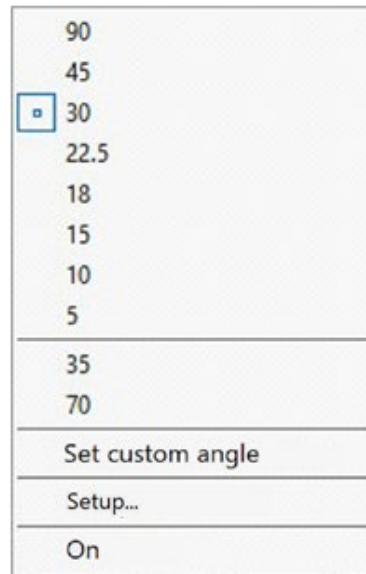

**Options of the POLAR button context menu:**

**90, 45, 30, 22.5, 18, 15, 10, 5**

List of standard, commonly used polar snap angles.

The current increment of the polar snap mode has the  icon.

**35, 70** (Sample values)

List of values of additional angles (if available).

**Set custom angle**

Sets a new angle increment using the command line.

*Command prompt:*

Enter angle: – enter the angle step (POLARANG system variable).

**Setup...**

Opens the **Drafting Settings** dialog on the **Snap** tab.

**On/Off**

Enables/Disables polar snap mode (AUTOSNAP system variable).

**To create a point at a specified distance and at a specified angle:**

On the **Snap and Grid** tab of the **Drafting Settings** dialog, enable the Snap mode by checking the **Snap On** box (**F9**). Set snap type – **Polar snap**. Enter the polar spacing.

On the **Polar Tracking** tab of the **Drafting Settings** dialog, enable the polar tracking mode by checking the **Polar Tracking On** box (**F10**). Set **Angle Increment:** and **Additional Angles**. Click **OK**.

Set the first construction point. Specify a point located at a soecified distance and at a specified angle.

## Object Snap Mode



Menu: **Tools** –  **Drafting settings...** **Object snap** tab



Status bar: the **OSNAP** button



Hotkeys: **F3**



Command line: **DDRMODES, DSETTINGS, SE**

Object snap is the main and the quickest way to specify an object's *characteristic points* without knowing their coordinates.

*Characteristic points* include:

- End points and the middle of a line,
- Center of a circle and its intersection points with center lines (quadrant),
- Endpoints, center and middle of an arc,
- Insertion point of block or text
- and others.
- 

The mechanism of object snap allows one of the characteristic points of the existing object to be specified as the coordinates for the point of a new object.

Object snap can be used when you need to set a point in the command line.

**To use object snap:**

1. Switch on *permanent object snap* in the **Drafting Settings** dialog box, select the **Object Snap On** check box and select the required mode:

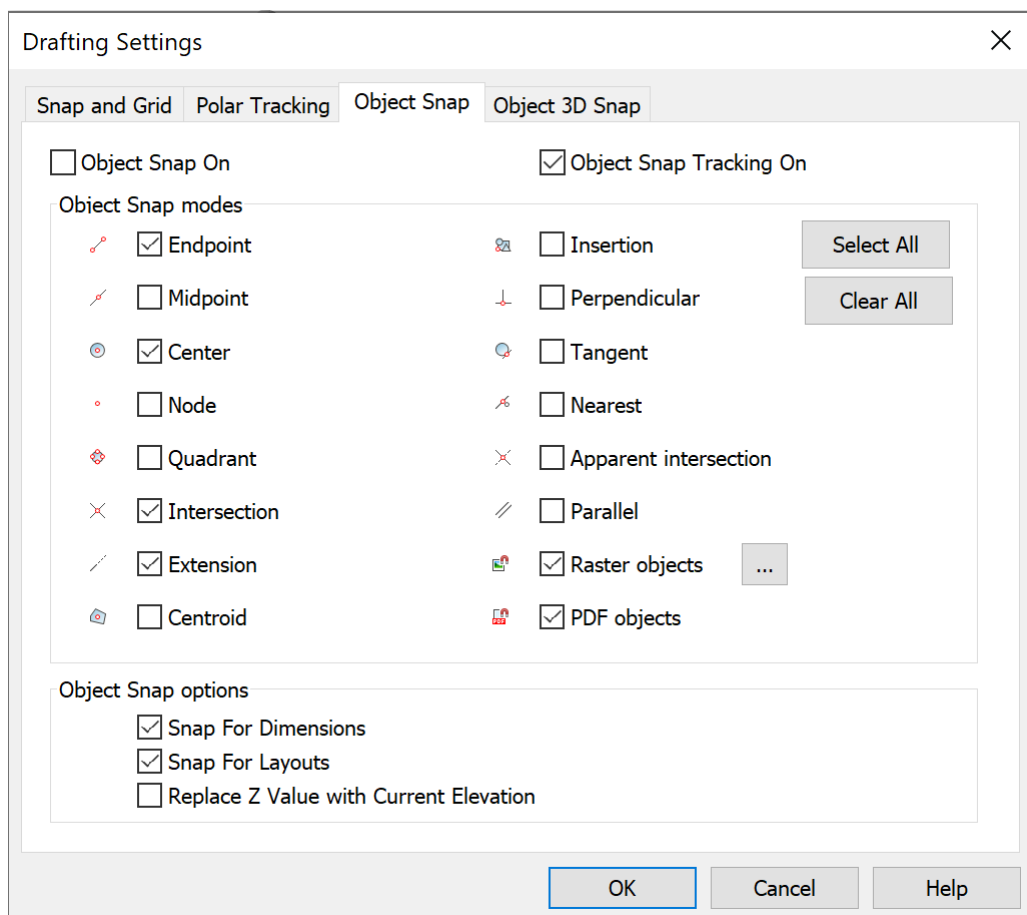

2. Switch on *permanent object snap*, open the context menu of the **OSNAP** button in the status bar and select the required mode:

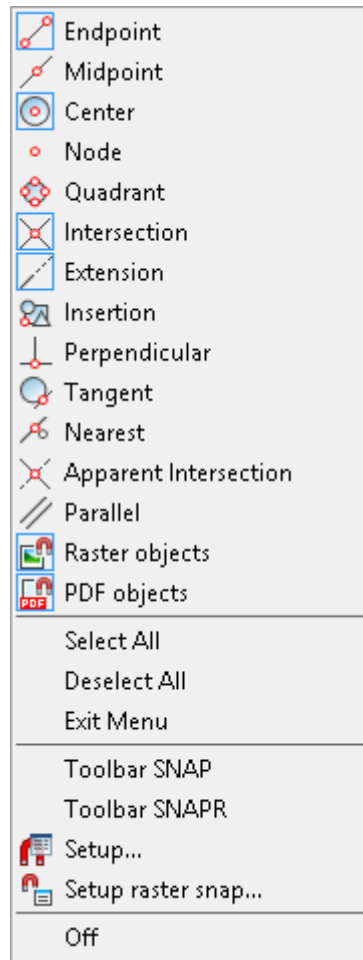

You can also enable or disable object snap modes in the **Object** toolbar:



It is possible to simultaneously turn on all or several object snap modes at once (except for the context menu of a single object snap – you can select only one mode in it).

The **Select All** and **Deselect All** options are applied to all snap modes at once.

3. Switch on *one-time object snap* during one of the creation or modifying commands, open the context menu of *one-time object snap* with **CTRL** (or **SHIFT**) button pressed and select the required mode:

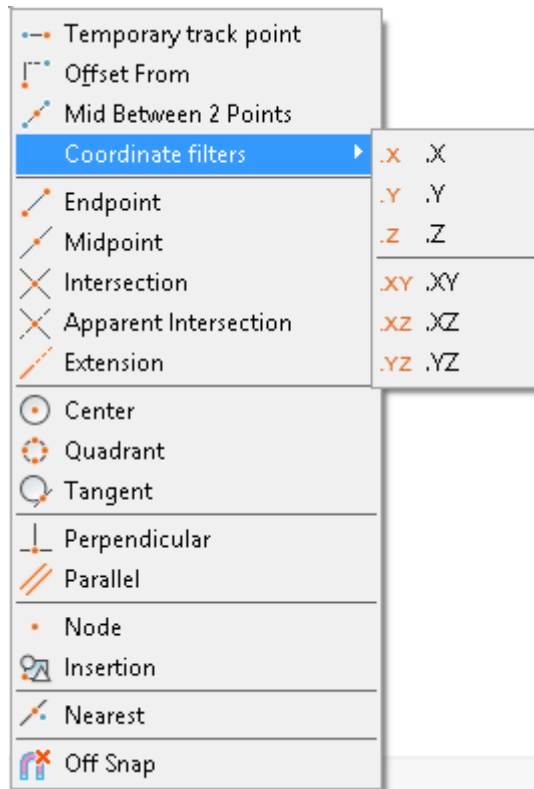

You can switch on one or several modes of object snap (except the context menu of *one-time object snap*, only one mode can be selected there).

The **Select All** and **Deselect All** are applied to all parameters of the snap.

*One-time object snap* is used to replace *permanent object snap* and stays active until the current snapping is finished. When a snap point is selected, *one-time object snap* switches off. For example, when creating geometric objects consisting of lines, as a temporary snap you can specify **Endpoint**, **Midpoint**, **Perpendicular** and **Intersection**. If you want to snap one of the lines to a circle, specify **one-time object snap**, **Center**, **Quadrant** or **Tangent**.

It is convenient to enable one-time object snap modes from the **Snap by request** toolbar:



You can also use keywords to invoke a one-time object snap. To do this, when requesting a point, enter the keyword of the corresponding snap and press **ENTER**.

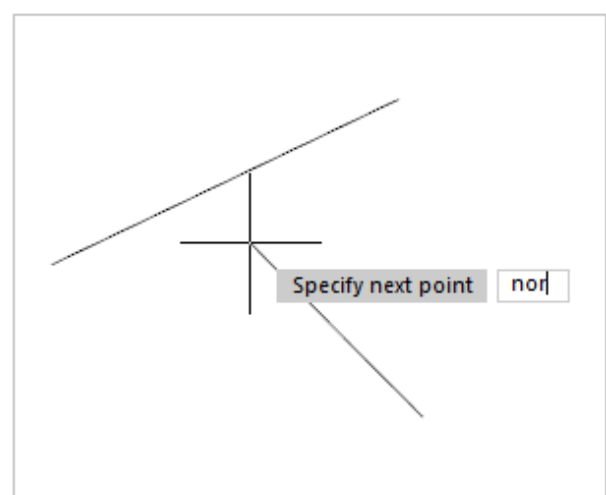
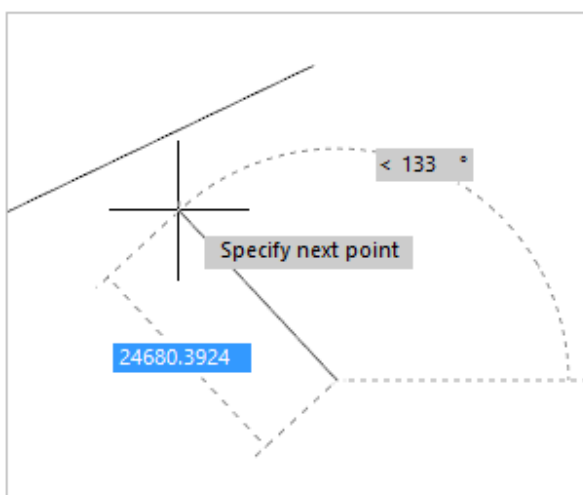

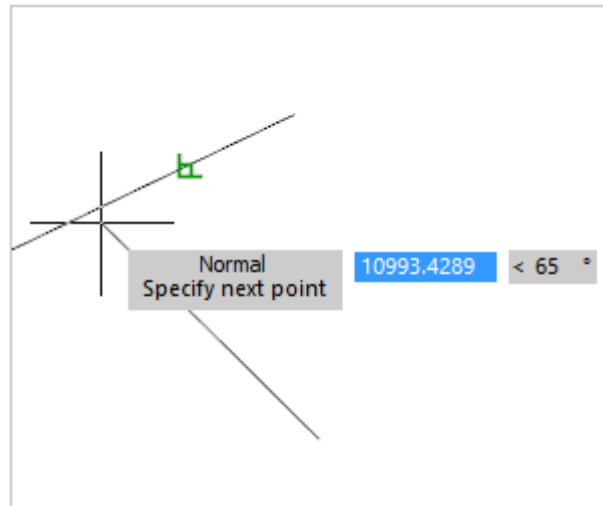

The list of keywords to activate a one-time object snap is given in the table below.

Keyword	Snap type
TT	Tracking point
FROM	From
M2P	Mid between two points
END	Endpoint
MID	Middle
INT	Intersect
APP	Apparent intersection
EXT	Line extension
CEN	Center
QUAD	Quadrant
TAN	Tangent
PERP	Perpendicular
PAR	Parallel
INS	Insertion point
NODE	Node
NEAR	Nearest
NONE	Disabling object snap

You can cancel the snap by request by pressing the button again, and you will return to the current (working) set of object snaps.

The context menu of *one-time object snap* has an additional option –  **None**, which switches off all modes of object snap before finishing the point selection operation. **None** is used for one-time application (during one operation), that is why it is absent in the **Object Snap** tab in the **Drafting Setting** and in the context menu of **OSNAP** button.

**None** is used when you cannot select a point in the drawing due to temporary snap modes being used. After the point is specified, the temporary snap mode starts again.

You can switch the object snap mode on/off in the **Snap** toolbar:



To open the **Snap** toolbar select the **Snap** option in the context menu of the **OSNAP** button:

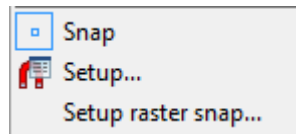









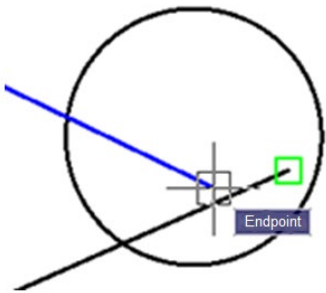

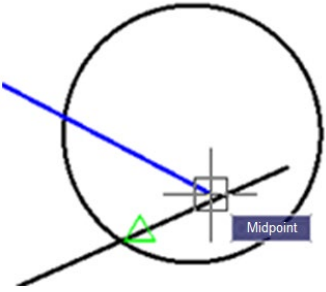

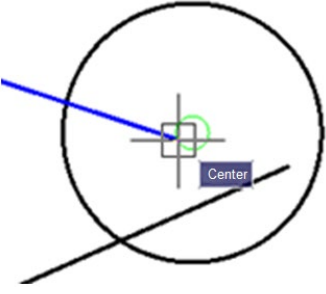
If an object snap mode is switched on, the marker and a tooltip about the available object snap types for the object are shown when moving the cursor over the object.

If several or all types of object snap are switched on as a permanent snap, and if a snap to some characteristic point is available in the cursor's current position (for example, if some objects are placed close to each other), the highest priority snap is used.

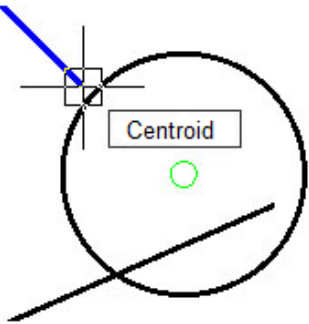

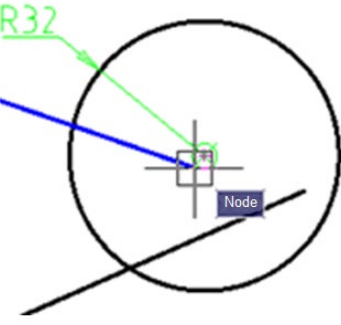

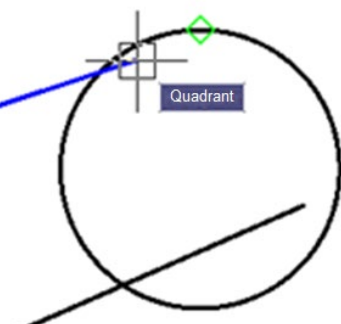

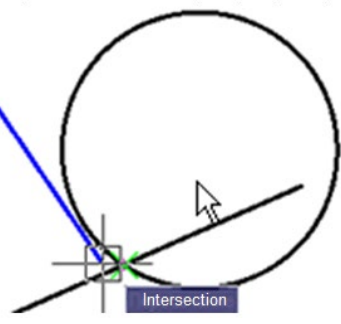

The priority of snaps is specified in the **Object Snap** tab in the **Drafting Setting**, the highest priority has **Endpoint**, the lowest – **Parallel**. Any one-time snap has a higher priority than any permanent **snap** has.

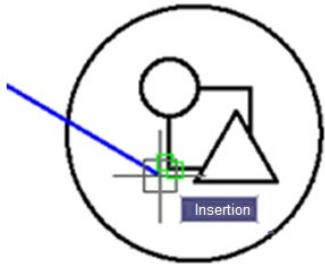
**Object Snap types:**

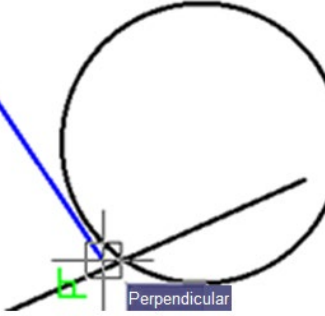
	<p><b>Endpoint</b></p>	<p>Snap to the object's endpoints (lines, arcs etc.).</p> 
	<p><b>Midpoint</b></p>	<p>Snap to the middle of objects (lines, arcs etc.).</p> 
	<p><b>Center</b></p>	<p>Snap to the center of an circle, arc or ellipse.</p>  <p><b>To perform snap:</b></p> <ul style="list-style-type: none"> <li>Place the cursor over the object. The "+" marker appears in the center of the object.</li> </ul>

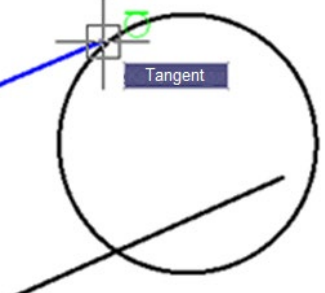
		<ul style="list-style-type: none"> <li>Place the cursor in the center of the object.</li> <li>When the marker is snapped, click.</li> </ul>
	<b>Centroid</b>	<p>Snap to the center of mass of closed objects (circle, ellipse, polyline, spline, region, block).</p> 
	<b>Node</b>	<p>Snap to a <b>Point</b> of the object, specifying point of dimension or start point of dimension text.</p> 
	<b>Quadrant</b>	<p>Snap to the nearest quadrant (the point located at an angle of 0, 90, 180 or 270 degrees from center) of arc, circle or ellipse.</p> 
	<b>Intersection</b>	<p>Snap to the intersections of objects (lines, circles, arcs etc).</p> 

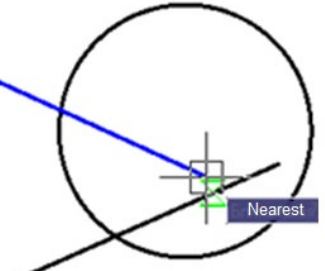

	<p><b>Insertion</b></p>	<p>Snap to an insertion point of text, block, shape or attribute.</p> 
	<p><b>Perpendicular</b></p>	<p>Snap to the point of the object lying perpendicular to another object or to its imaginary extension.</p> 
	<p><b>Tangent</b></p>	<p>Snap to the point on an arc or circle belonging to the tangent of another object.</p> 
	<p><b>Nearest</b></p>	<p>Snap to the point of the object located closest to the cursor position.</p> 
	<p><b>Parallel</b></p>	<p>Snap to an existing linear segment for the creation of a parallel linear segment of another object.</p> <p>After specifying the first point of a linear segment, you need to place the cursor's over a linear segment of the existing object and slowly move the cursor to the expected position of a parallel segment of a new object. The symbol of a parallel snap on the existing object and parallel rubber line to this object means that you can specify the second point of the linear segment at any required place in the rubber line.</p>

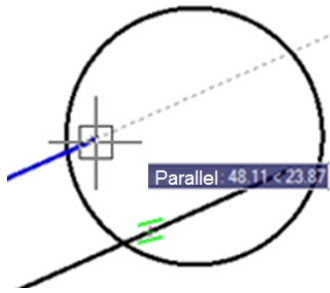
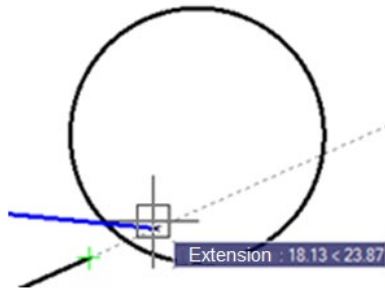
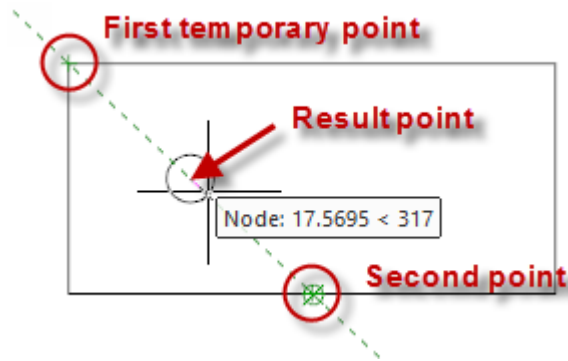
		
	<b>Extension</b>	<p>Creates a temporary auxiliary line which is an extension of an object and the cursor goes over its end point.</p> 
	<b>Offset from</b>	<p>Snap to point which offset by a specified distance from temporary control point.</p> <ol style="list-style-type: none"> <li>1. Specify temporary control point.</li> <li>2. Specify the offset by relative point or by direct-distance method.</li> </ol>
	<b>Middle between 2 Points</b>	<p>Snap to middle point between two specified points.</p> 
	<b>Coordinate filters</b>	<p><a href="#">Coordinate filters</a> allow you to input the coordinates of a point for each axis separately, specifying coordinates first along one axis, then along another. You can enter the following filters: <b>.x</b>, <b>.y</b>, <b>.z</b>, <b>.xy</b>, <b>.xz</b> or <b>.yz</b>.</p>

 **Raster objects** mode ensures object snap to characteristic points of inserted raster image objects.

 **PDF object** mode allows the object snap to PDF underlay objects as to vector objects.

### ***Object Snap Settings***

#### *Snap to Dimensions*

Enables/Disables snapping to intersections of dimension and extension lines.

#### *Snap for Layouts*

Enables/Disables snapping to the borders and center of the layout.

### *Replace the Z value with the current level value*

Manages the Z coordinate value for object snap.

When the option is disabled, the Z coordinate value of the specified point is used.

When the option is enabled, the value of the Z coordinate is replaced by the value of its projection onto the XY plane of the current UCS or, if the **ELEVATION** variable is set to a non-zero value, to a plane parallel to the XY plane at the specified level. The option is synchronized with the **OSNAPZ** variable.

Below there are two 3D polylines constructed with snap to the vertices of the mesh. Red – in normal snapping mode, blue – when the Z-coordinate replacement option is enabled:

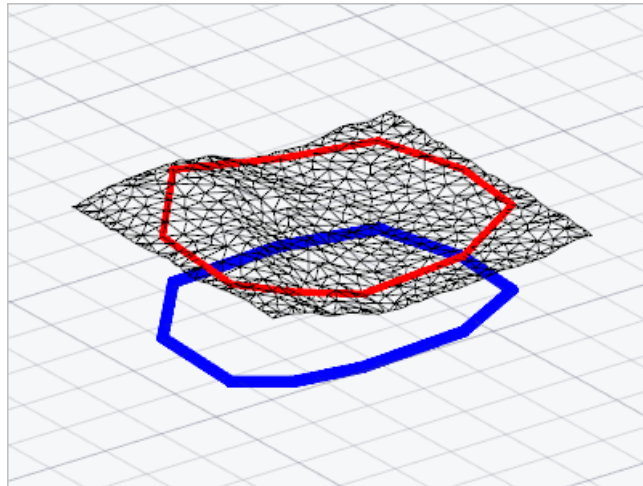

## **Snap to Raster Objects**

There is a snap to characteristic points of object of monochrome raster image.

### *To perform a snap:*

- Insert raster image into a document.
- Specify [settings of a raster snap](#).
- Switch on the **Raster** object snap in the **Object Snap** tab of the **Drafting Settings** dialog or from the context menu of the **OSNAP** button in the status bar.
- Select required types of object snap in the **Object Snap** tab of the **Drafting Settings** dialog.

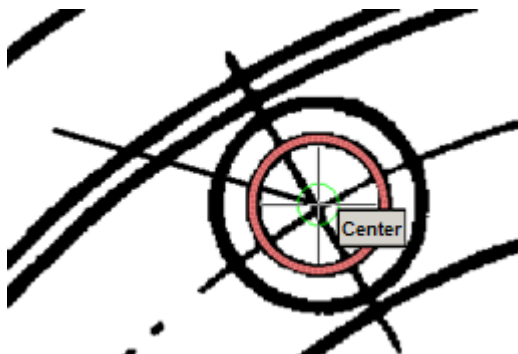

The program recognizes a type of raster object, highlights it and snaps to its characteristic points according to selected modes of object snap:



## **Settings of Raster Snap**



Menu: **Tools – Drafting Settings > Object snap** tab >  button

 Status bar: context menu of **OSNAP** >  **Setup raster snap**

 Command line: **R2VSNAPSETUP**

Raster snap have to be setup to help program to recognize types of raster objects (lines, arcs, circles) correctly.

Snap operations are based on recognizing algorithms for raster objects. The program calculates a vector object, ideally approximating raster lines, which are close to mouse pickbox and offers to snap to characteristic points of the object. The efficiency of raster snap highly depends on parameters, specified in the **Raster Snap Settings**.

**To specify settings for a raster snap:**

1. Open **Raster Snap dialog** from context menu or by  button near **Raster** on **Object Snap** tab from **Drafting Settings** dialog.
2. Set raster snap settings in accordance with your raster image characteristics:

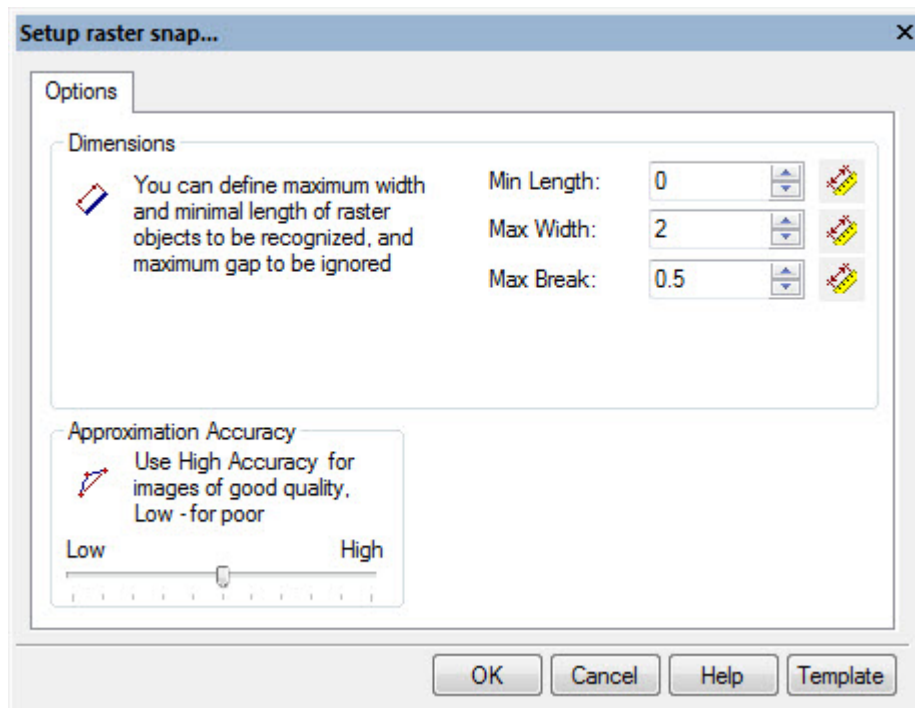

**Settings:**

**Min Length:** This parameter defines the minimum size of a raster object that can be recognized.

**To set Min Length:**

- Click  button and specify distance (2 points on raster line) that should be recognized as line.
- or
- Enter value to the field.

**Max Width:** This parameter defines the maximum width of raster lines that can be approximated by lines, arcs, circles, and polylines. If the width of a raster line exceeds **Max Width** value, then the only possible recognition mode is Auto tracing and approximating with an outline object.

**To set Max Width:**

- Click  button and specify by 2 points maximum width of raster.
- or
- Enter value to the field.

It's better to set this value a little more than maximum width of the thickest line in the image.

**Max Break:** Sets the length of the maximum ignored breaking raster lines. If a raster line is broken into parts it should be traced as an entire object, then the value of **Max Break** should be set to the largest gap between the raster line parts. The program will ignore the breaks and create single vector object, approximating the whole raster line. By setting a comparatively large value of the parameter, users can, for example, trace dash-dotted raster lines, and arcs as single entities.

**To set Max Break:**

- Click  button and specify by 2 points the largest gap between the raster line parts.
- or
- Enter value to the field.

**Accuracy** This parameter determines the accuracy of approximation of the original raster object with a vector one. If the original image is distorted (for example, circles have the form of ellipses), then reduce the value of the **Approximation Accuracy** parameter. However, this leads to inaccuracies in recognition, for example the program might take a short arc for a line. When the quality of a raster image is high, increase the value of the **Approximation Accuracy** parameter. Sometimes before tracing the quality of the raster image can be improved by application of a smoothing filter.

**To set Approximation Accuracy:**

- Move slider.

If the original raster entities are distorted (for example, raster circles have an elliptical shape), recognition accuracy will increase when moving the slider to the left, to the **Min** value. If the original raster image is of good quality, the slider should be moved to the right, to the **Max** value.

3. When ready – click **OK** button.

## Object 3D Snap



Menu: **Tools** –  **Drafting settings** > Tab **Object 3D snap**

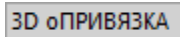

Status bar:  **3D ОПРИВЯЗКА**

 Hotkey: **F4**

 Command line: **DDRMODES, DSETTINGS, SE**

Allows you to make a snap to location points of 3D Solids and shapes recognized in the point cloud by shape recognition commands.

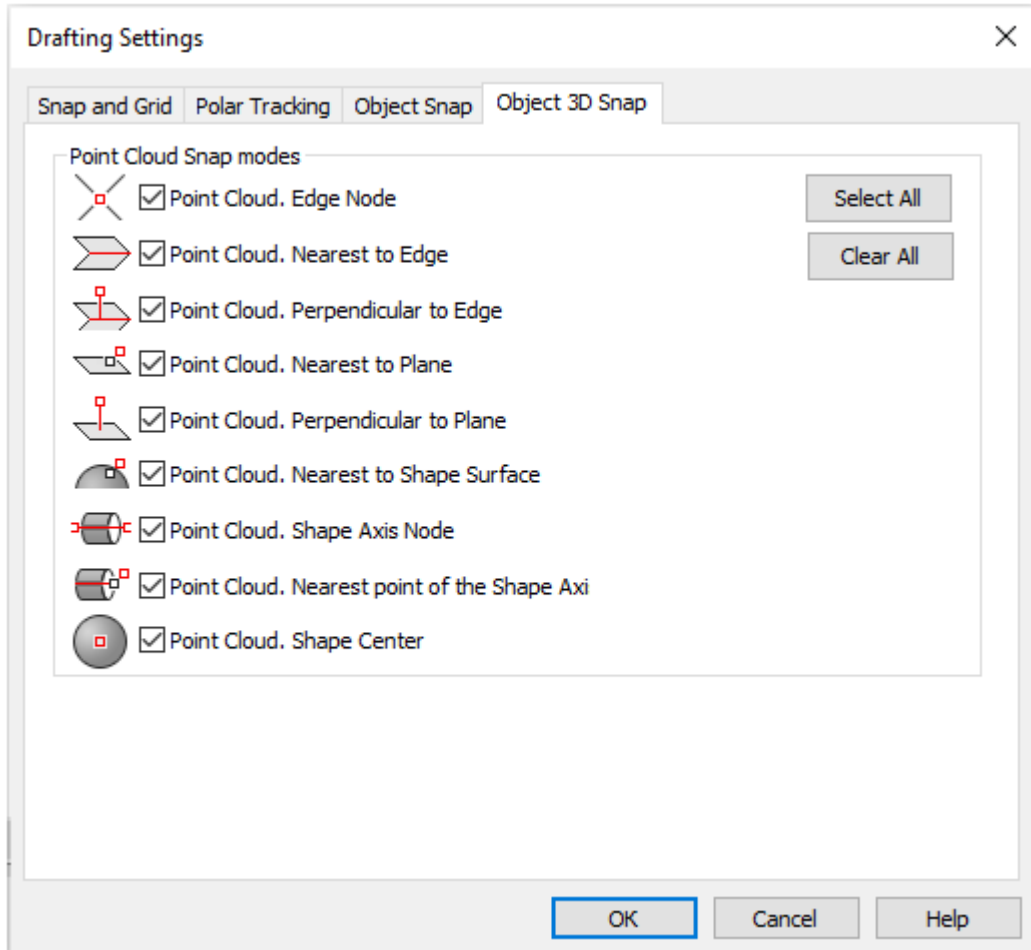

**Modes of object 3D snap:**

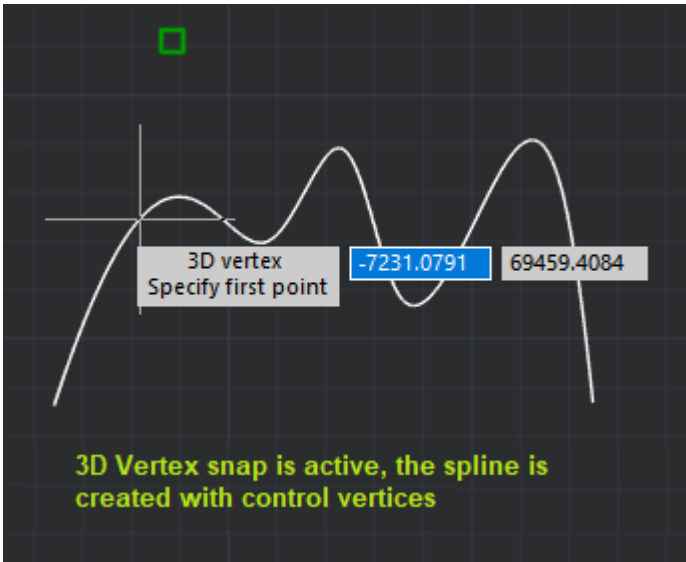
<p><b>Edge Node</b></p>	<p>Snap to the nearest vertex of a 3D object or to a control vertex on a spline created with control vertices.</p>  <p><b>3D Vertex snap is active, the spline is created with control vertices</b></p>
<p><b>Midpoint</b></p>	<p>Snap to the midpoint of a face edge.</p>

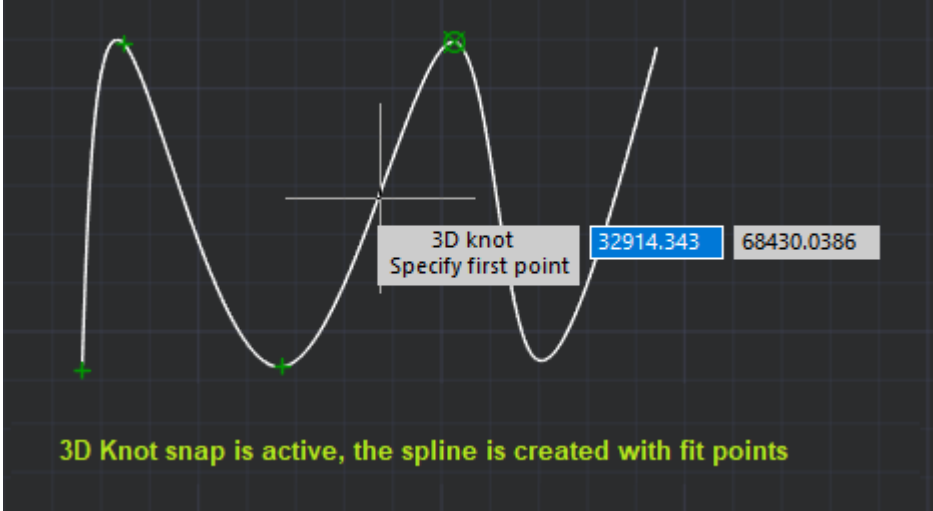
<b>Shape Center</b>	Snap to a face center.
<b>Node</b>	Snap to a node on a spline created with fit points. 
<b>Normal</b>	Snap to a point normal to a face.
<b>Nearest to Plane</b>	Snap to the point closest to the face of the 3D object.

3D Object Snap modes can be cycled through using the **TAB** key when **Dynamic Input F12** is disabled.

### Snap to point clouds

For the possibility to snap to location points of geometric shapes recognized in a cloud, the **snap to features** mode should be enabled:

 Ribbon: **Point Clouds > Settings >**  **Snap to edges and nodes**

 Menu: **Point Clouds – Settings >**  **Snap to Edges and Nodes**

 Command line: **SWITCHPCSNAPFEATURES**

## Object Snap Tracking Mode

 Menu: **Tools – Drafting settings... Object snap** tab

 Status bar: the **OTRACK** button

 Hotkeys: **F11**

 Command line: **DDRMODES, DSETTINGS, SE**

The object snap tracking mode allows the placing of created objects in specific relation to other created objects. When object snap tracking mode is switched on, nanoCAD temporarily displays dotted trajectories of different types (tracking lines) for accurate positioning of objects.

Object tracking modes are used together with object snap and works when the cursor's pickbox is near a probable point of object snap (the pickbox size determines the zone of tracking lines activation). Object tracking expands and adds to the capabilities of object snap.

The parameters of object tracking are specified in the **Tracking and Object Snap** tabs in the **Drafting Setting** dialog box and in the context menu of the **OTRACK** button.

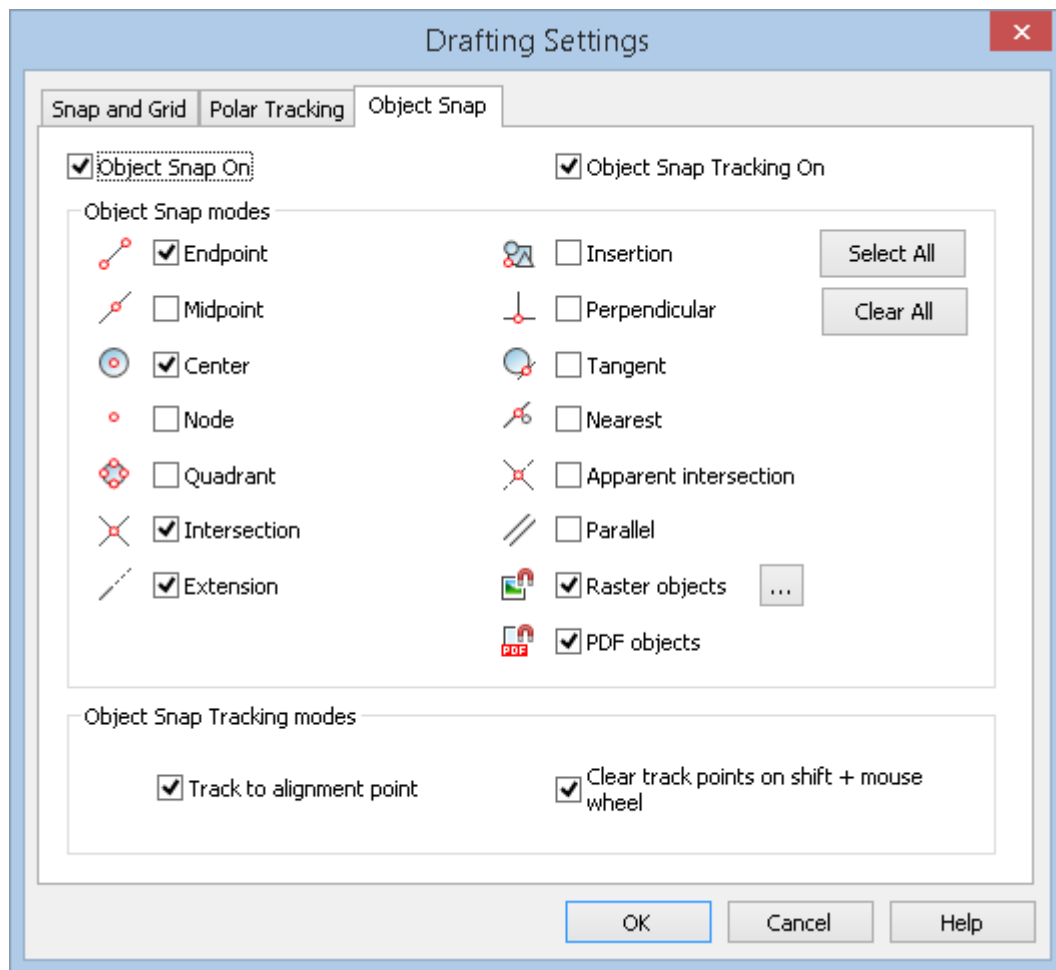

**Parameters:**

**Object Snap Tracking On (F11)**

Switches object snap tracking mode on/off.

The context menu of the **OTRACK** button:

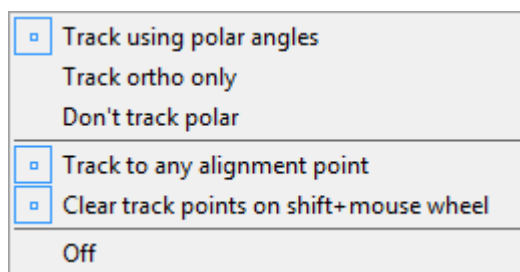



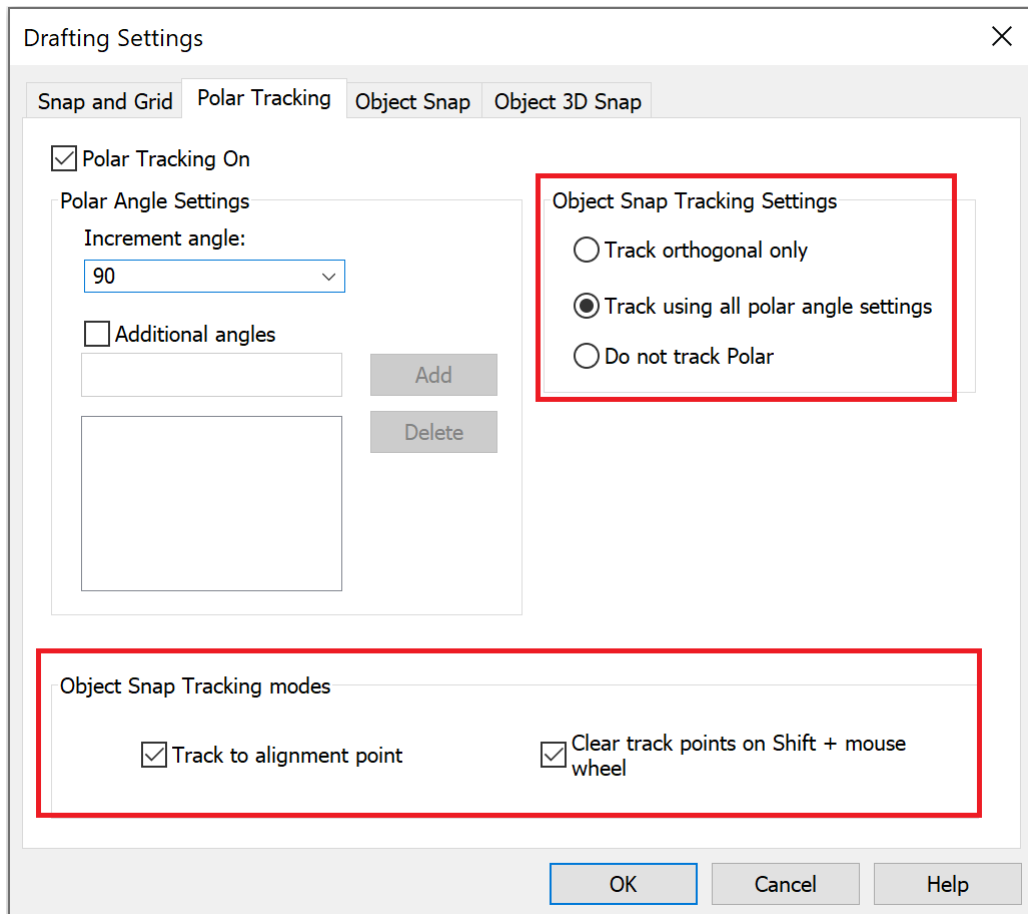

### Object Snap Tracking modes

#### Track to alignment point

Switches on/off the display of tracking lines to an object's characteristic points.

#### Clear track points on "shift + mouse wheel"

Switches on/off the erasing mode of the snap point marker on a tracking line using **SHIFT** and the mouse wheel. When the mode is enabled, markers can only be erased using the "shift + mouse wheel" combination. When the mode is disabled, the markers are also erased when zooming/panning.

### Object snap

#### Track using polar angles

Switches using object tracking together with polar tracking mode on/off. In this case, the tracking lines for all angles specified in the **Polar Tracking** tab in the **Drafting Settings** dialog box are displayed.

#### Track ortho only

Switches the display of tracking lines only in ortho directions on/off.

#### Don't track polar

Switches off polar tracking mode.

### To use object tracking mode:

1. Switch on the **OTRACK** and **OSNAP** modes in the status bar.

2. Use the cursor to capture the required characteristic objects' points to set tracking lines. Place the cursor near a point to capture it. A captured point is marked with + symbol. To deactivate a point already captured, move the cursor over it again.
3. Dotted tracking lines, going through one or several captured points and the cursor's pick box, will appear when you move the cursor within the drawing. You can snap to points on those lines or to the intersection points. The more types of object snap that are switched on, the more points will be available for capture.

To zoom and pan, the + marker is removed from captured points.

**Example: Circle in the center of a rectangle.**

1. Defining the center of rectangle:

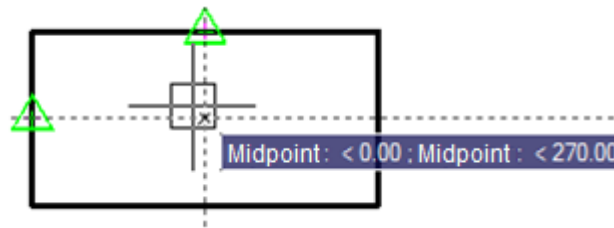

2. Specifying the circle center:

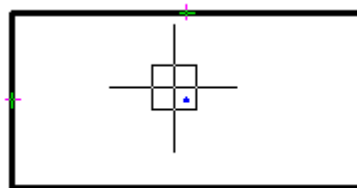

3. Specifying the circle radius:



## Display of Snap Elements



Menu: **Tools** –  **Options...**

The cursor's pick box is enlarged automatically in nanoCAD snap modes, when you need to snap to characteristic points of objects (creation and editing of primitives, dimensioning etc):

Common cursor's pickbox size

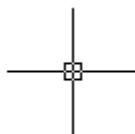

Enlarged cursor's pickbox size

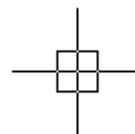

The common cursor's pick box size is specified in the **Cursor – PickBox – PickBox size** section of the **Options** dialog box (**Tools** menu – **Options**):

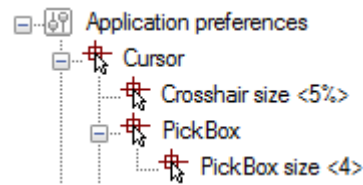

**Parameters:**

- Crosshair size** Sets the size of the crosshair as a percentage of the display size.
- PickBox size** Pick box size in pixels.

The enlarged cursor’s pick box is specified in the **Options** dialog in the **Snap settings – Hold Aperture Size:**

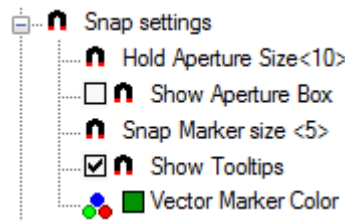

**Parameters:**

- Hold Aperture Size <10>** The size of the cursor frame in snap mode.
- Show Aperture Box** Switches the aperture box on/off in the snap mode.
- Snap Marker size <5>** Snap marker size.
- Show Tooltips** Turns on the display of the snap name.
- Vector Marker Color** The color of the snap marker when snapping to a vector object.
- Otrack Marker Color** Sets the color of the object tracking marker when snapping to a vector object.
- Rays Color** Specifies the color of rays when snapping to a vector object.

## ORTHO Mode

 Status bar: the **ORTHO** button

 Hot key: **F8**

 Command line: **ORTO**

With orthogonalisation mode set on, vector lines and rubber lines for editing can only be drawn in directions parallel to the coordinate axis.

If an angle of a coordinate system is changed, the corresponding ortho mode angle is also changed.

The **ORTHO** mode has higher priority than the polar tracking mode.

**NOTE:** You can temporarily switch off the **ORTHO** mode by pressing and holding the **SHIFT** button when the command of creation or object editing is running.

## Dynamic Input

 Status bar: Button **DYN**

 Hot key: **F12**

Dynamic input displays the command interface near the cursor in the drawing area. At the right time, current prompts, command requests, input fields, lists of selectable keywords, dimensions of edited geometry are displayed next to the cursor.

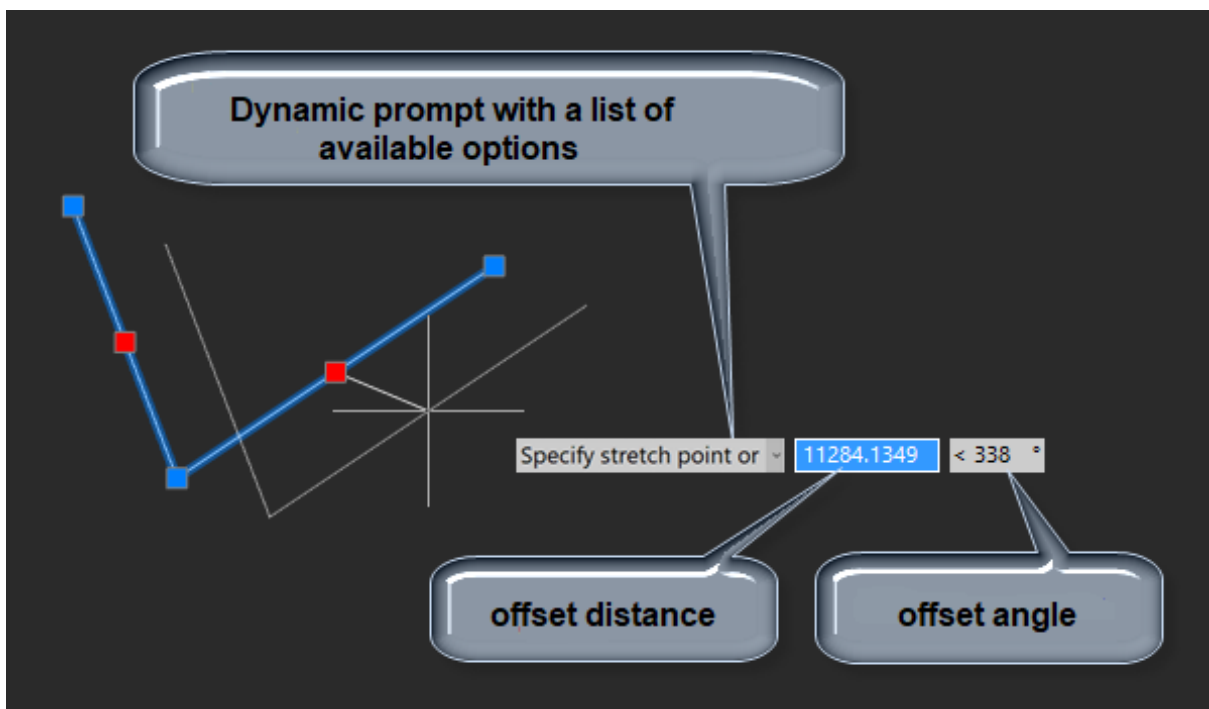

Dynamic input consists of three functional parts:

- Pointer Input;
- Dimension Input;
- Dynamic Prompts.

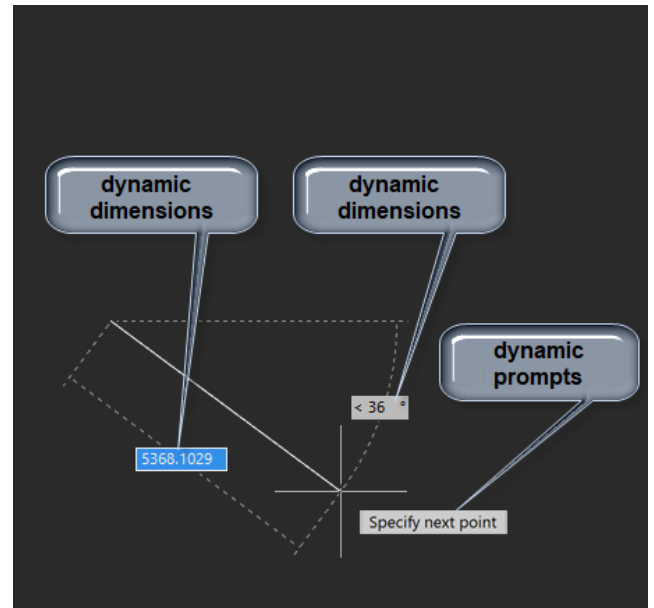
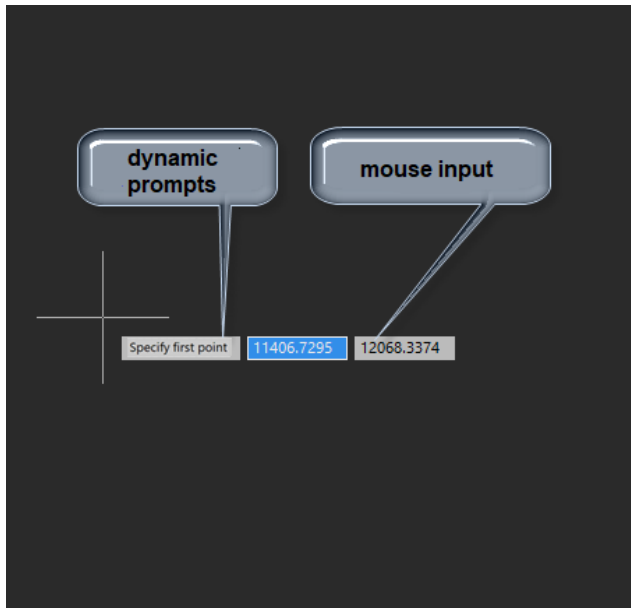

You can adjust them or switch them off in the **Dynamic Input** section of the **Options** dialog.

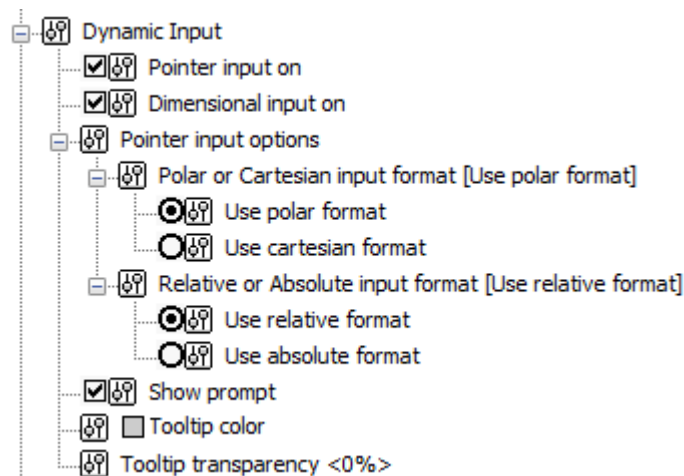

## Dimension Input

Dynamic dimensions are displayed when creating and editing lines, arcs and circles. The values of dynamically displayed dimensions can be edited, which makes it more convenient to draw and edit, when the exact distances, dimensions and angles of segments are known.

When constructing a linear segment, an arc segment or a circle, their linear and angular dimensions are displayed on the screen relative to the previous point. Dimensions are displayed with a thin dashed line. With the moving of cursor in the drawing, the values of dynamically displayed dimensions continuously change reflecting the current dimensions. By pressing **TAB** key it is possible to pass to the desired dimension value to edit it from the keyboard. Upon the input completion, press **ENTER**.

When moving the cursor to the grip of preselected objects, the dimension values associated with it are dynamically displayed on the screen. When moving the cursor to the grip belonging to several selected objects, the dimensions of each object associated with this grip will be displayed.

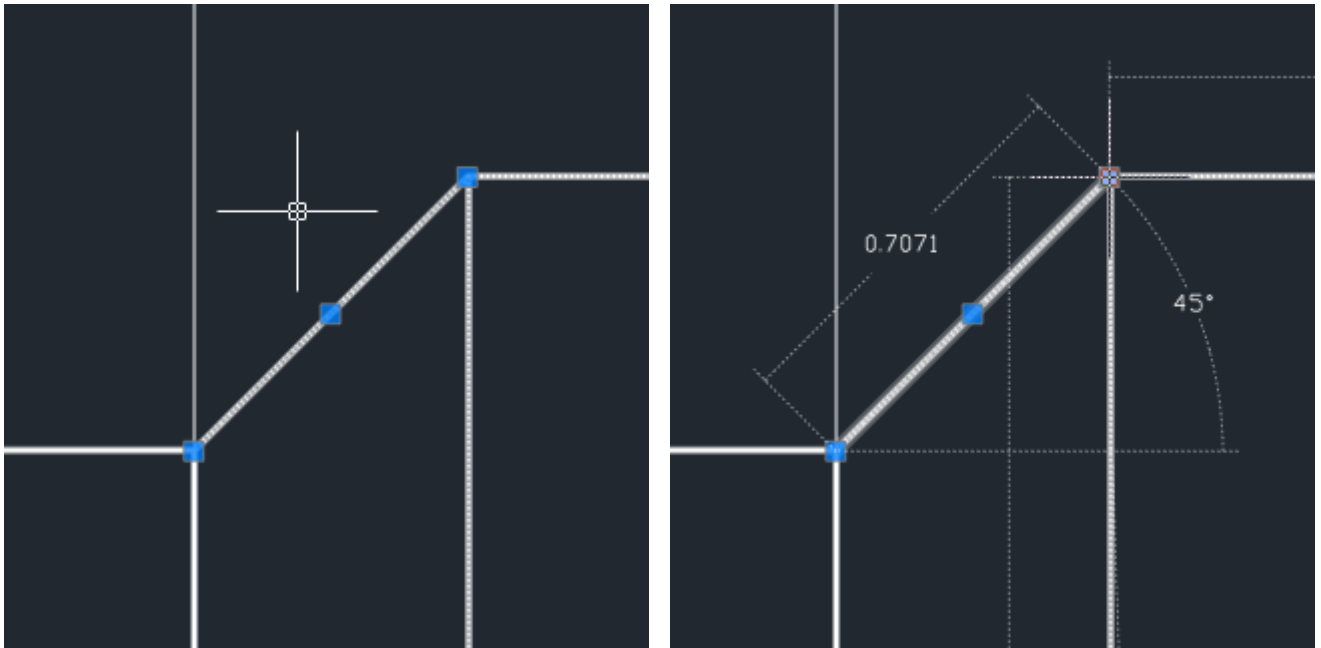

When selecting the object **grip**, the values of dynamically displayed dimensions become available for editing. By pressing **TAB** key, move to the desired value. Enter a new value from the keyboard.

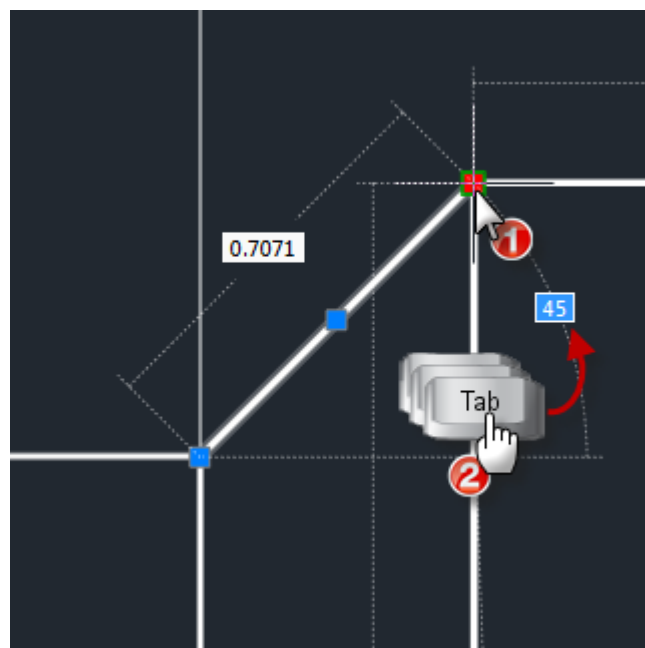

To move to the next dimension value, press **TAB**. The edited dimension will fix its value, and the lock icon will be displayed in its right part.

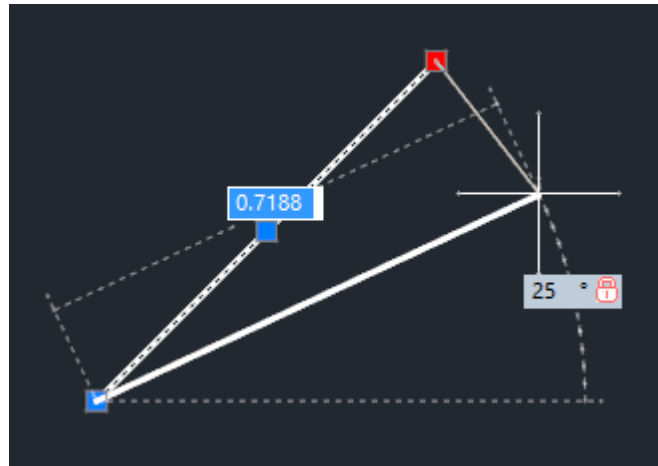

To complete the editing, press **ENTER**.

Not all dynamic dimensions can be seen on the screen simultaneously. The number of simultaneously displayed dimensions is controlled by the DYNDIVIS variable. Depending on its value, the following can be displayed simultaneously:

- only one dimension (DYNDIVIS = 0):

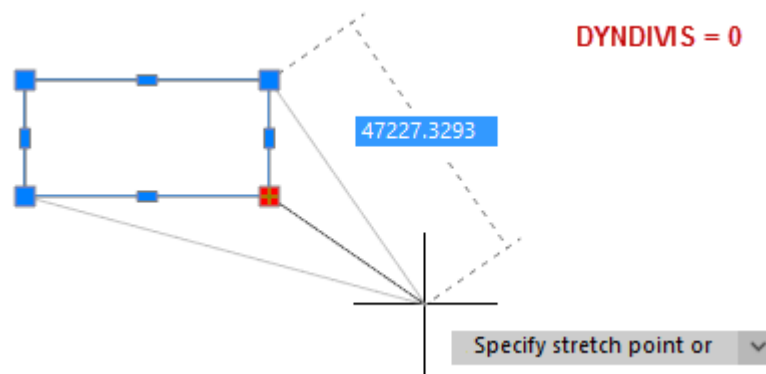

- only two dimensions (= 1):

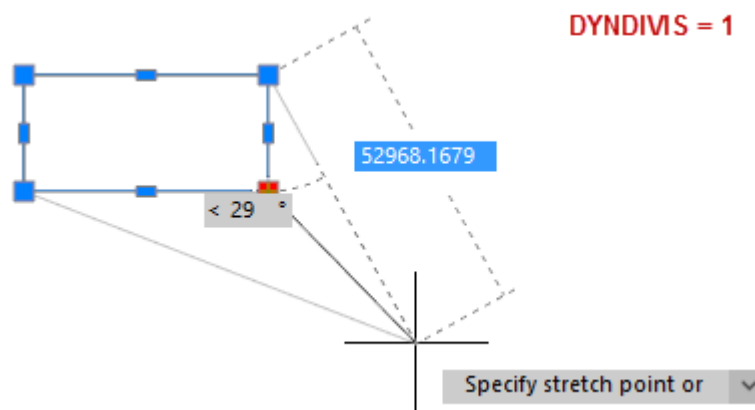

- or all dimensions (= 2):

DYNDIMS = 2

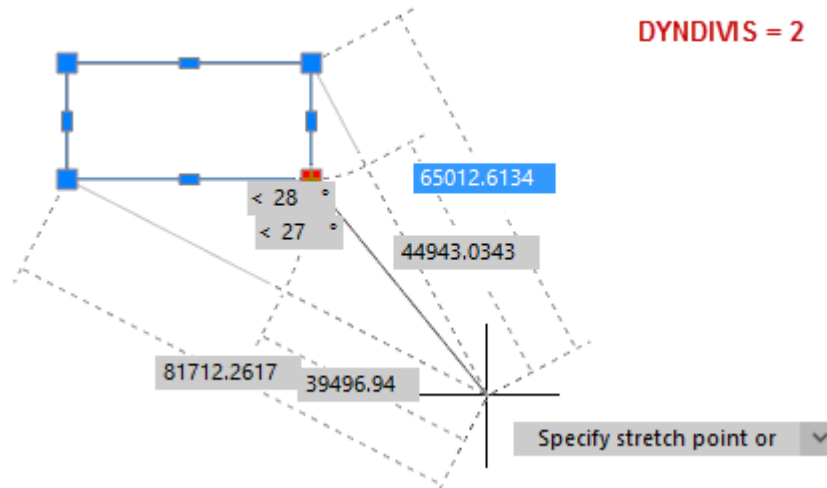

If only one or two dimensions are displayed simultaneously, and you need to display others, this can be done by cyclically pressing the **TAB** key. Press **TAB** until the desired dimensions are visible. On subsequent cursor movement, the selected dimensions will continue to be displayed.

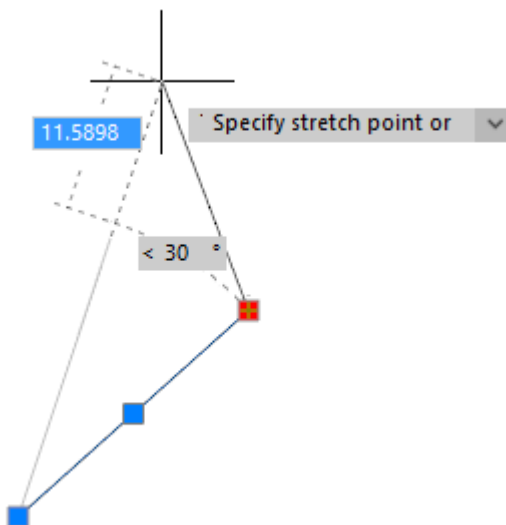
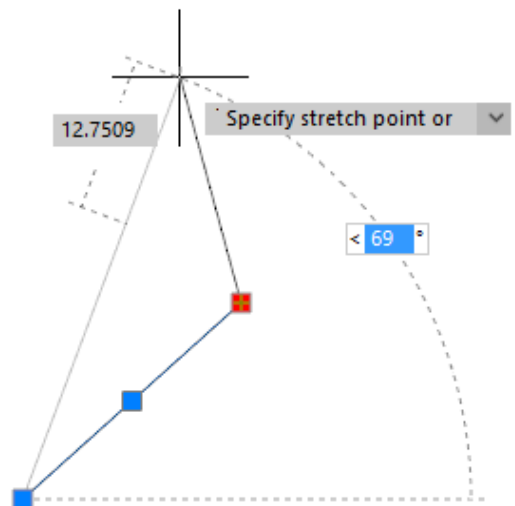
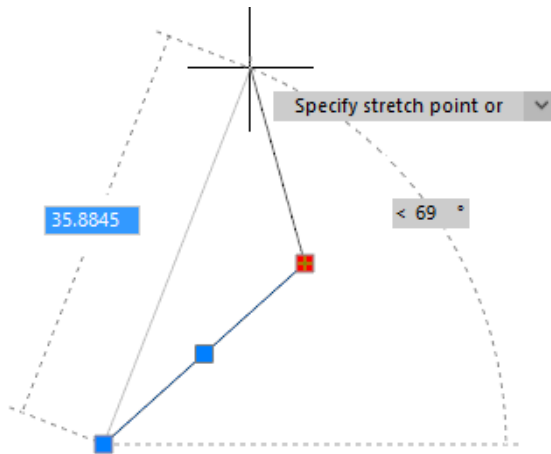



## Pointer Input

When a point is requested by a command, you can enter its coordinates in the tooltip box near the crosshair, where the current cursor coordinates are shown.

By toggling the **TAB** key, switch to necessary value to edit it from the keyboard. Press **ENTER** when done.

### Entering coordinates with dynamic dimensions mode on

If, in addition to the mouse dynamic input, the dynamic dimensions mode is enabled, then while entering the second and subsequent points of the object being created, the coordinate field is not displayed explicitly.

In this case, do not be embarrassed, just start entering the point coordinates using the keyboard: enter the coordinate along the X axis, enter a comma and continue entering coordinates along the remaining axes, separated by commas. For example: 12045,-430.07,0.005 Or -45,28

The value being entered will first display in the field of one of the dynamic dimensions.

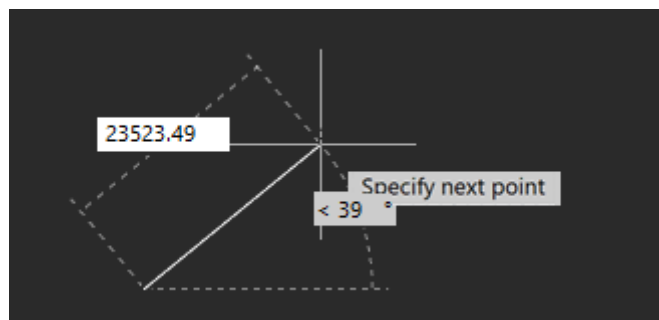

After entering the first comma, the coordinate fields begin to be displayed explicitly near the cursor.

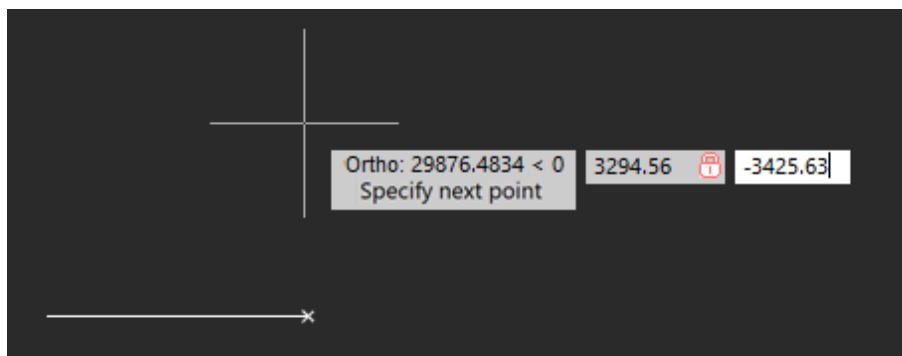

By pressing the **TAB** key, you can move to the desired value to edit it from the keyboard. When finished entering, press **ENTER**.

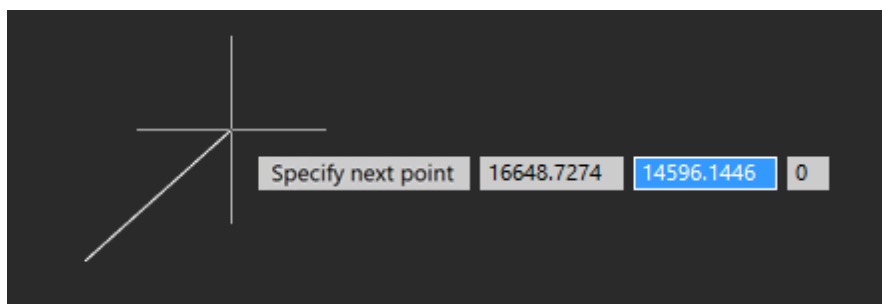

When switching between fields using **TAB**, the direction of the base (zero) angle is assumed to be **East, Counterclockwise**, regardless of what is specified in the **Drawing Units (UNITS)** dialog.

For example, when entering like: 300**TAB**30, where 300 is the length, 30 is the angle, the base angle will always be **East**, counting **Counterclockwise**.

The direction of the base angle specified in the **Drawing Units** dialog will be taken into account for the following input options:

@300**TAB**30  
 @300<30  
 300<30

## Dynamic Prompts

Dynamic prompts provide an alternative way to enter command parameter values. In the tooltip field near the cursor, requests and prompts of the active command appear, necessary to complete the command. Data can be entered in the dynamic prompt fields instead of the command line. You can enter command keywords and requested numeric values.

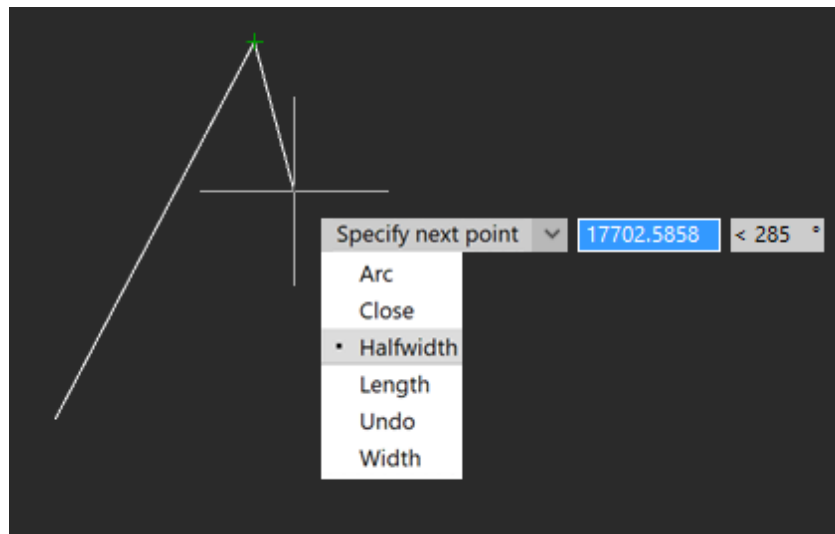

The list of available values and options can be expanded by pressing the **DOWN ARROW** key on the keyboard. Then choose the desired value with an **ARROW** keys and press **ENTER**.

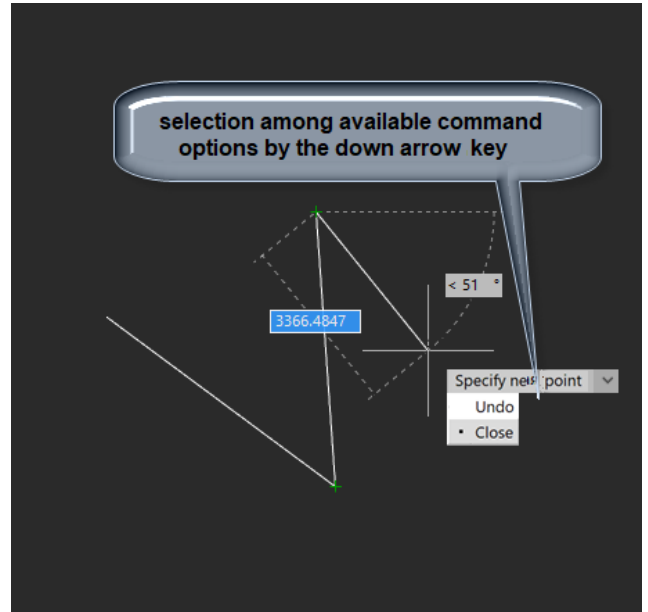
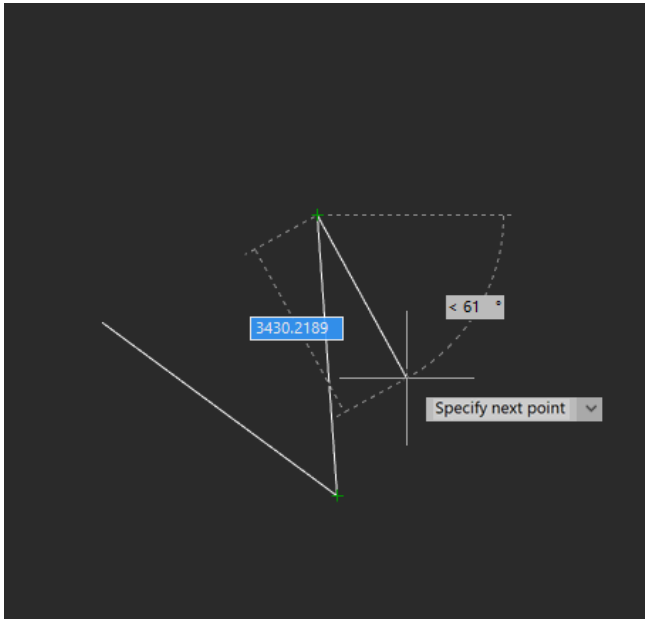

# GRAPHIC DISPLAY MANAGEMENT

*View* is a combination of the size, position and orientation of a drawing fragment on the screen.

There are different tools and methods allowing you to orient in the document when you edit it. You can zoom or pan the working area for visual control of changes in the document; you can save a selected view for further display or printing; you can separate the working area of a document into several non-overlapping viewports to display different drawing fragments at the same time.

## Display Modes

The main methods to change the document display on the screen are *zooming* and *panning*.

*Zoom* command enlarges the view of a drawing segment for better detailing or decreases it to display more of the drawing. Absolute sizes are not changed during zooming.

*Pan* command allows you to pan the drawing without decreasing or enlarging it.

**Zoom** and **Pan** commands are available in the **View – Zoom** menu or on the **Zoom** toolbar. For your convenience, most frequently used commands are on the **Main** toolbar and in the status bar.

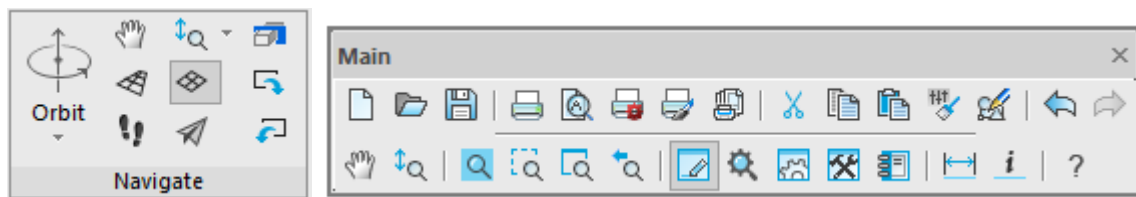



For more convenience, the most often used commands are also available in the **Main** toolbar and in the status bar.



**NOTE:** You can zoom using the mouse wheel. Moving the mouse with the wheel pressed and held allows panning.

## Pan Command

 Ribbon: **View – Navigate >**  **Pan**

 Menu: **View – Zoom >**  **Pan**



 Toolbar: **Main –** 

 Status bar – 

 Command line: **PAN, VIEWPAN**



The mode to pan the image, occurs when you move the cursor with pressed left button, the image is moved dynamically to horizontal, vertical and diagonal directions. The scale of the document is not changed.

After starting the command, the cursor has the  shape.

With the left button pressed, the cursor has the  shape. In a perspective projection, the center relative to which the movement will be carried out is highlighted with a colored icon - a blue sphere .

To exit from pan mode, press the **ESC** or **ENTER** buttons.

## Zoom

 Status bar –  **Navigate**

 Command line: **ZOOM, Z**

Turns on the mode in which you can increase an object's size on the screen by moving the mouse up and decrease it by moving it down. All available options are displayed in the command line:

Specify corner of window or  
 [All/Center/Dynamic/Extents /Scale/RScale/Window/Object] <real time>:

### Command options:

All Displays the entire document on the screen, even if some of its objects are outside the established limits.  
 Identical to calling the  **All** command.  
 In this document display mode, not only the boundaries of the drawing are taken into account, but also the boundaries of the established document limits:

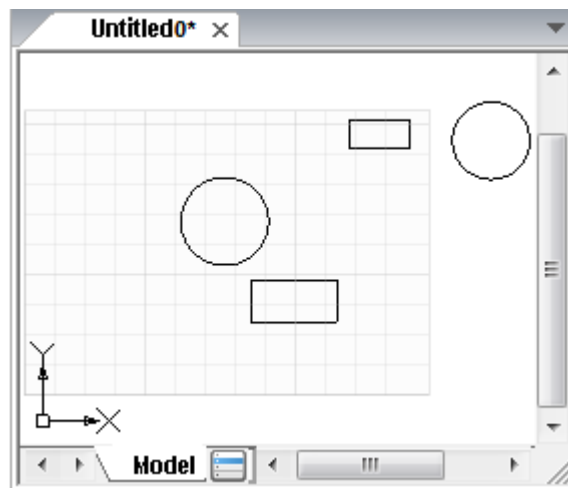

Center Places the image in the center of the screen. Scale of the document is not changed, only the image is panned.  
 Displays the image in the center in the specified point with given scaling coefficient or height.

Identical to launching the  **Center** command.  
 Setting height value less than current one leads to image increase.  
 Setting larger value results in image reduction

Dynamic Changes scale of the image on the screen in real time.

Identical to calling the  **Real time** command.  
 The cursor's movement enlarges the image on the screen, if the left button of mouse is pressed and the cursor goes. The image decreases on the screen, if the left button of the mouse is pressed and the cursor goes

down.

Extents

Displays the entire document inside its borders.

Identical to calling the  **Borders** command.

Borders of the specified document limits are not taken into account (in comparison with All):

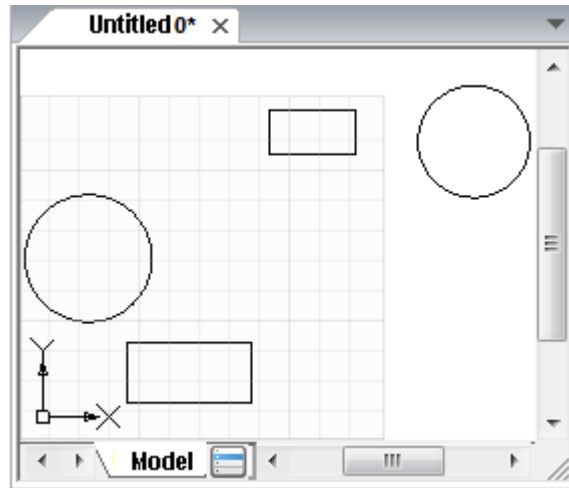

Previous

Consecutive display of previous views on the screen.

Scale

Changes the scale of the document using the precise scale factor.

Identical to calling the  **Scale** command.

The image on the screen is decreased or increased according to the specified document limits and the value.

RScale

Changes the document scale using the precise scale factor.

The image on the screen is decreased or increased relative to the limits of the current document view and according to the specified value.

Window

Specifies display area of the document using two opposite corners of a rectangular frame.

Identical to calling the  **Window** command.

Object

Displays selected objects of the document on the screen.

Identical to calling the  **Selected** command.

Select one or several objects on the screen after you select the Object option. The image is displayed after all objects are selected and the **ENTER** button is pressed.

If objects were selected beforehand – the display of image is reconstructed after the Object option is selected.

## Realtime



Ribbon: **View – Navigate** >  **Realtime**



Menu: **View – Navigation** >  **Zoom realtime**



Toolbars: **Main, Navigate** – 



Status Bar – 



Command line: **ZOOMD, VIEWZOOMDYNAMIC**

Turns on the interactive image zooming mode, in which moving the mouse cursor with the left button pressed and held up the screen enlarges the view on the screen, and moving downward – reduces it.

After starting the command from the **View** menu or the **Main** toolbar, the cursor looks as follows:

 follows:

Releasing the mouse button suspends the zoom, you can move the cursor to a different position, and then click again to continue zooming in the new position.

To exit the zoom mode, press **ESC** or **ENTER**.



**NOTE:** In addition, it is convenient to zoom in by rotating the mouse wheel. In this case, the zoom step can be set in the **Mouse settings – 3D Orbit settings – Mouse wheel to rotate 3D orbit** of the **Options** dialog, box

## Window

 Ribbon: **View – Navigate** >  **Window**

 Menu: **View – Navigation** >  **Zoom Window**

 Toolbars: **Main, Navigation** – 

 Status bar – 

 Command line: **ZOOMW**

Sets the display area of the document by specifying two opposite corners of a rectangular frame.

In the process of specifying, for precise positioning of the window, it is convenient to use a one-time object snap from the context menu calling it by clicking the right mouse button while holding **CTRL** (or **SHIFT**).

## Scale

 Ribbon: **View – Navigate** >  **Scale**

 Menu: **View – Navigation** >  **Zoom scale**

 Toolbar: **Navigation** – 

Changes the scale (zoom rate) of a document by specifying the exact scale factor.

The screen image is enlarged or reduced by a specified value relative to the specified document limits.

## Zoom 1:1

 Ribbon: **View – Navigate** >  **Zoom 1:1**



 Menu: **View – Zoom** >  **Zoom 1:1**



 Command line: **ZOOM1, VIEWZOOM1X1**

An image is scaled so that one pixel on the screen corresponds to one image point according to the specified DPI value.

## Zoom Center

 Ribbon: **View – Zoom** >  **Center**

 Menu: **View – Zoom** >  **Center**

 Toolbar: **Zoom** – 

Displays image in the center in the specified point with given scaling coefficient or height.

Command prompts:

Specify center point:

Enter magnification or height <200.00>:



First specify the point that will be the center of zoomed fragment, and then set magnification or height. One can enter numeric value in the command line or determine height by specifying two points on the screen.

Setting height value less than current one leads to image increase. Setting larger value results in image reduction.

## Zoom All

 Ribbon: **View – Navigate** >  **Zoom All**

 Menu: **View – Zoom** >  **Zoom All**

 Toolbar: **Main** – 

 Status bar: 

 Hotkeys: **ALT+0**



 Command line: **ZOOMALL, VIEWZOOMALL**

Displays the whole document, even if some objects are outside the specified limits.

## Zoom Selected

 Ribbon: **View – Navigate** >  **Zoom Object**

 Menu: **View – Zoom** >  **Zoom Selected**

 Toolbar: **Main** – 

 Command line: **FITSEL, FITSELECTED**

Displays the selected objects.



## Zoom Window

 Ribbon: **View – Navigate** >  **Zoom Window**



 Menu: **View – Zoom >  Zoom Window**

 Toolbar: **Main – **

 Status bar – 

 Command line: **ZOOMW**

Selects an area on the screen, the area is specified with two opposite corners of the rectangular frame.

## *Zoom In*

 Ribbon: **View – Navigate >  Zoom In**

 Menu: **View – Zoom >  Zoom In**

 Command line: **ZOOMIN**

Doubles the scale.

## *Zoom Out*

 Ribbon: **View – Navigate >  Zoom Out**

 Menu: **View – Zoom >  Zoom Out**

 Command line: **ZOOMOUT**

Decreases the scale by half.

## *Extents*

 Ribbon: **View – Navigate >  Extents**

 Menu: **View – Navigation >  Zoom Extents**

 Toolbar: **Navigation – **

Displays the entire document on the screen within its extents.

In this mode of displaying a document (in contrast to the [All](#) option), the boundaries of the set document limits are not taken into account.

## *Previous*

 Ribbon: **View – Navigate >  Previous**

 Menu: **View – Navigation >  Zoom Previous**

 Toolbar: **Navigation – **

Sequential display of previous views on the screen.

## Setting of the Orthographic and Isometric Views

To quickly set the view, select the **View – Views** and select the required standard orthographic and isometric views.

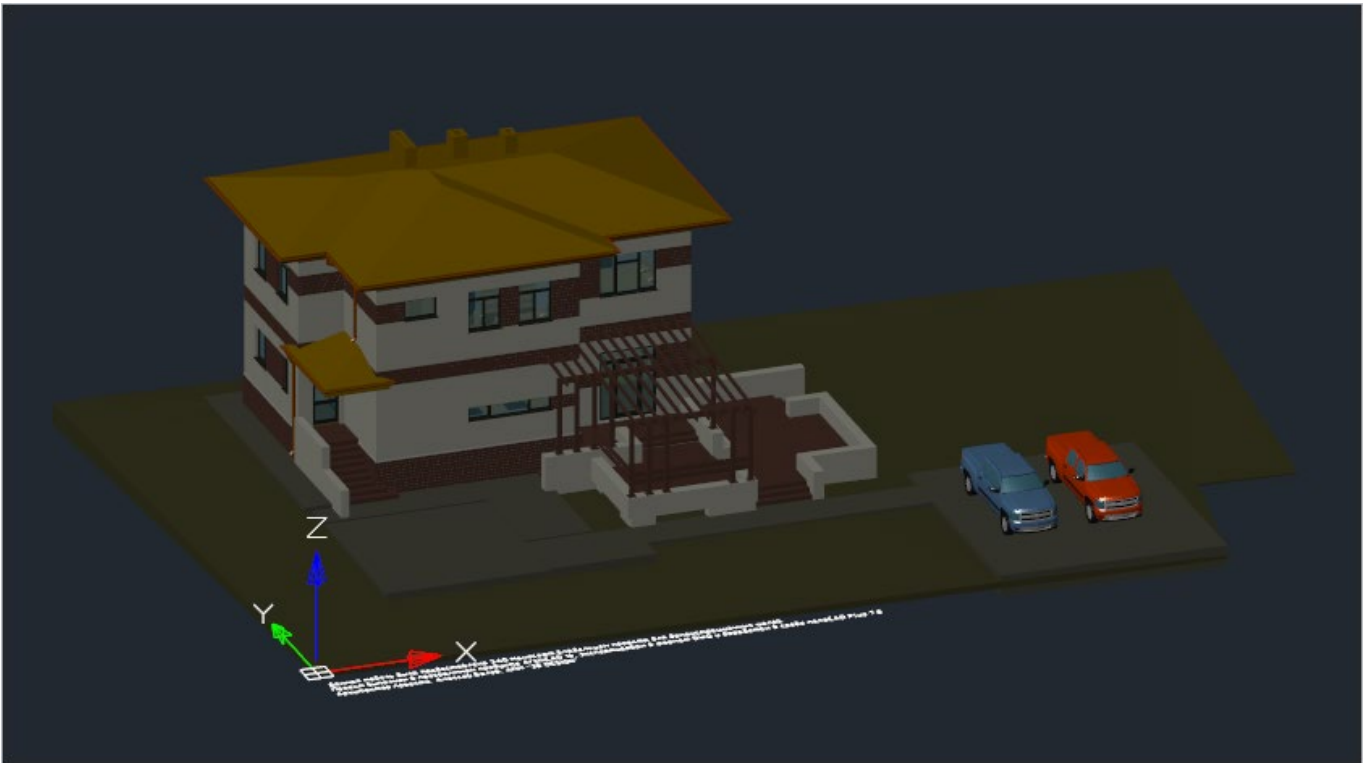

### Orthographic Views

#### Set Top



Menu: **View – Views** >  **Set Top**



Command line: **VIEW1**

Set the top view.

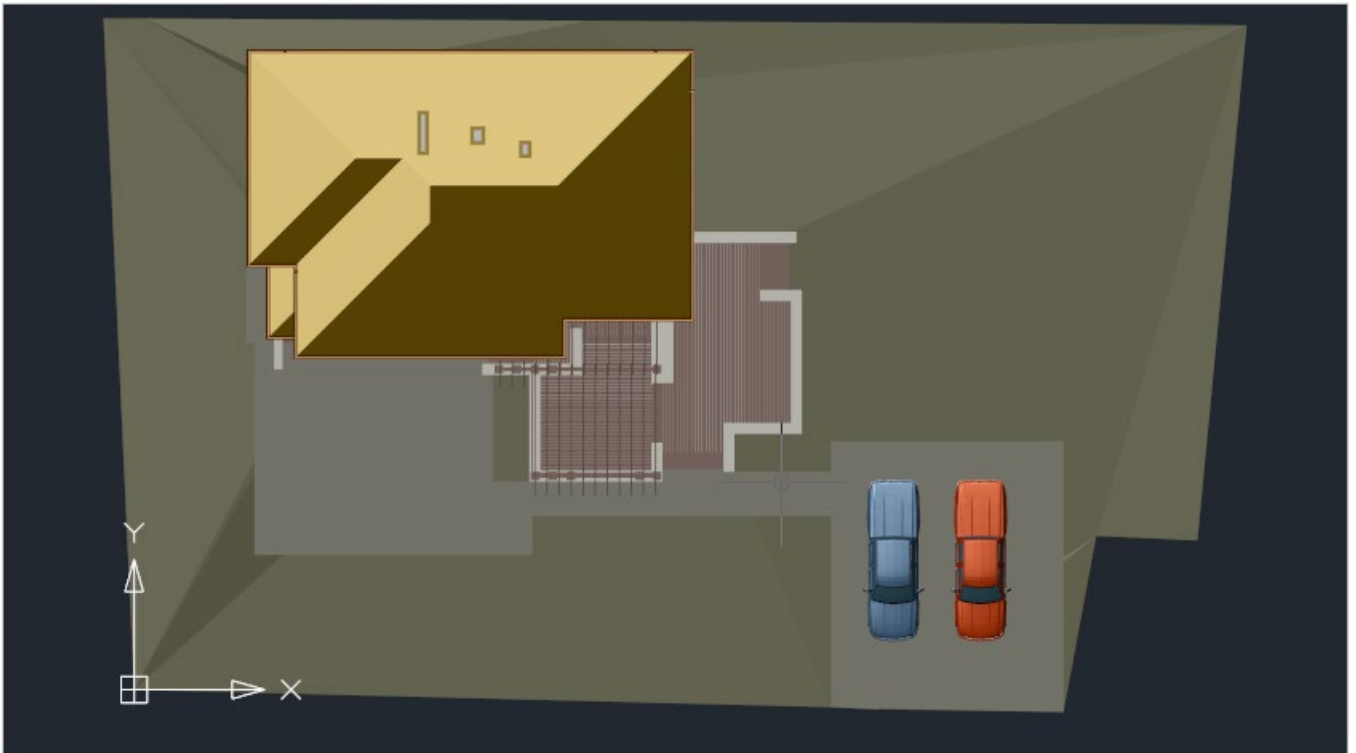

## Set Bottom



Menu: **View – Views >**  **Set Bottom**



Command line: **VIEW2**

Set the bottom view.



## Set Left



Menu: **View – Views** >  **Set Left**



Command line: **VIEW4**

Set the left view.

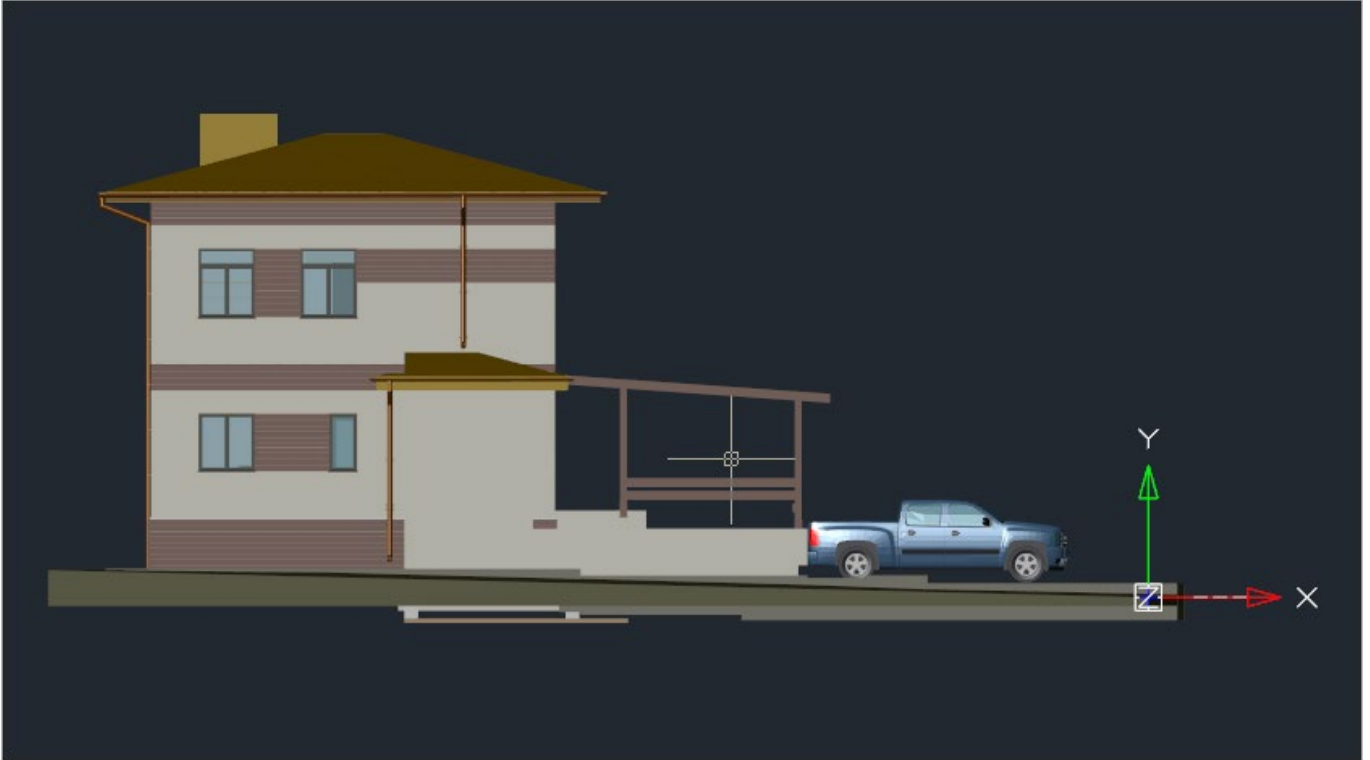

## Set Right



Menu: **View – Views** >  **Set Right**



Command line: **VIEW5**

Set the right view.



## Set Front



Menu: **View – Views >**  **Set Front**



Command line: **VIEW3**

Set the front view.



## *Set Back*



Menu: **View – Views >**  **Set Back**



Command line: **VIEW6**

Set the back view.



## *Isometric Views*

### *SW Isometric*



Menu: **View – Views >**  **SW Isometric**



Command line: **SWISO**

Set the southwest isometric view.



## *SE Isometric*



Menu: **View – Views** >  **SE Isometric**



Command line: **SEISO**

Set the southeast isometric view.



## *NE Isometric*



Menu: **View – Views** >  **NE Isometric**



Command line: **NEISO**

Set the northeast isometric view.

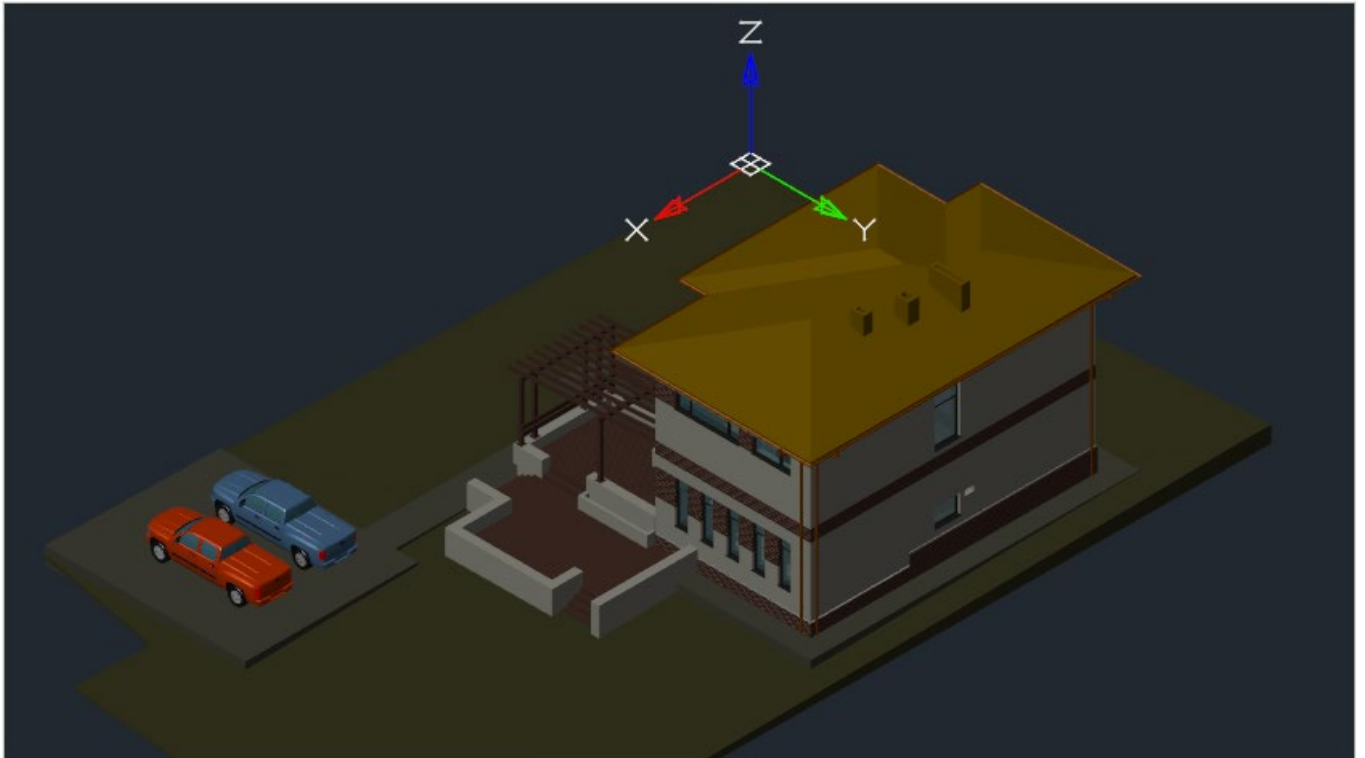

## *NW Isometric*



Menu: **View – Views** >  **NW Isometric**



Command line: **NWISO**

Set the northwest isometric view.





## Managing the Display of Annotative Objects

Annotative objects are usually scaled differently than drawing views. Annotative objects are defined not by the model size, but by the sheet height. They are assigned with one or more scales. A scale depends on how such objects should look when printed.

If you have annotative objects in the drawing, you can control their display.

### Display of annotative objects according to the current scale

 Ribbon: **Annotate – Annotation Scaling** >  **Current Scale**

 Menu: **View – Show Annotative Objects** >  **Current Scale**

### Display of all annotative objects











 Ribbon: **Annotate – Annotation Scaling** >  **All Scales**

 Menu: **View – Show Annotative Objects** >  **All Scales**

**NOTE** If a drawing has a large number of scales, this may slow down the processing of that drawing and other drawings that reference the drawing. To remove unused scales, it is recommended to delete scales by running the **-PURGE** command and selecting the **Annotative scales** option. This check is also carried out when opening a document.

## 3D Navigation

### 3D Orbit

-  Ribbon: **View – Navigate** >  **Orbit**
-  Ribbon: **Point clouds – Navigate** >  **3D Orbit**
-  Menu: **View – Orbit** >  **3D Orbit**
-  Toolbar: **View** – 
-  Command Line: **3DORBIT**
-   hold down the mouse wheel + **SHIFT**

Rotate view in 3D when camera moves on horizontal and vertical orbits.

Cursor will be changed to:  .

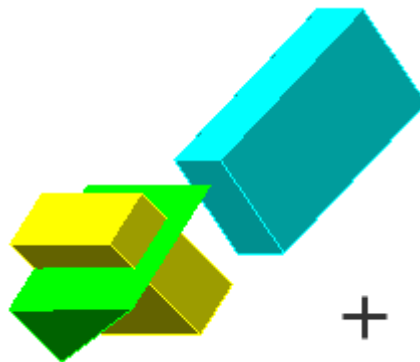

The target of the view stays stationary while the camera location, or point of view, moves by mouse movements.

If you are moving cursor horizontally – camera is moving in XY plane of the WCS. If you are moving cursor vertically – camera is moving along Z-axis.

The example below shows the rotation of the view relative to a point located on a translucent object “window glass”.



You can set orbit options in **Mouse settings – 3D Orbit settings – Orbit center** in **Options** dialog box.

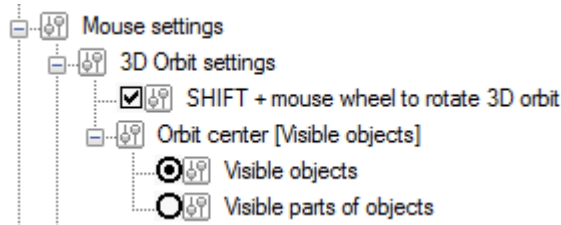

Set one of two center point location:

**Parameters:**

**Visible objects** Center of the objects you’re viewing is the center of orbit. Thus if you see the part of circle, center of this circle is orbit center.





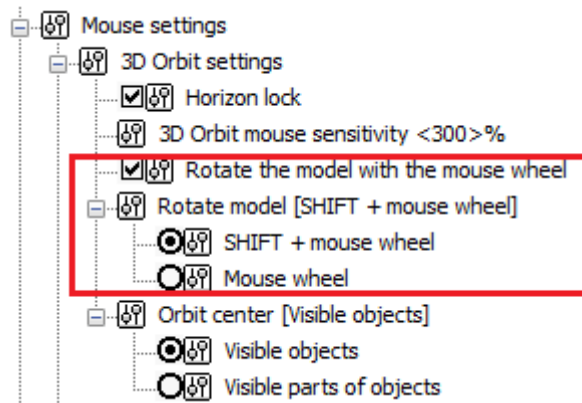



**Visible parts of objects** Center of the objects parts you’re viewing is the center of orbit. Thus if you see the part of circle, center of this part is orbit center.

The **Orbit** command can be activated at any time in out-of-command mode by pressing the mouse wheel or by pressing **SHIFT** + wheel, depending on the settings:



To disable the possibility to call the **Orbit** using the mouse wheel (with and without **SHIFT**), uncheck **Rotate the model with the mouse wheel** box. This can be useful when working in a 2D projection, for example, with a geodetic plan.

## Free Orbit

-  Ribbon: **View – Navigate** >  **Free Orbit**
-  Ribbon: **Point clouds – Navigate** >  **Free Orbit**
-  Menu: **View – Orbit** >  **Free Orbit**
-  Toolbar: **View** – 
-  Command Line: **3DFORBIT**

Orbits in any direction without reference to the planes.

Cursor will be changed to: .

The **Free orbit** type has an arcball, which is geometrically a big circle divided into four quadrants by four small circles. The camera position moves around the target. By default, the target point is the arcball center, it does not coincide with the geometric center of the set of objects being considered.

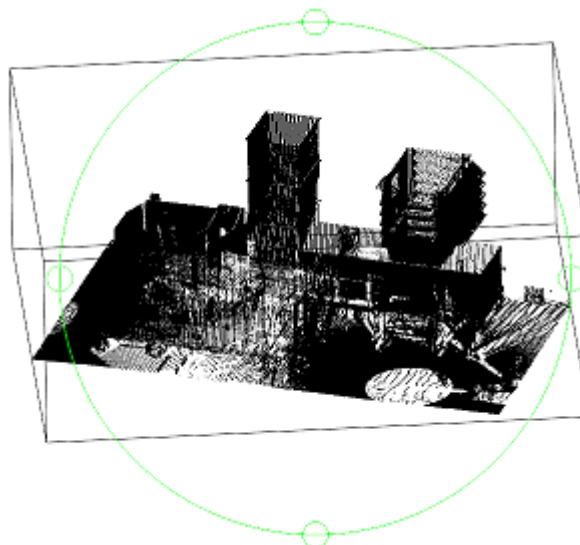

The position of target point (orbit center) can be set in the **Mouse settings – Orbit settings – Orbit center** section of the **Options** dialog box.

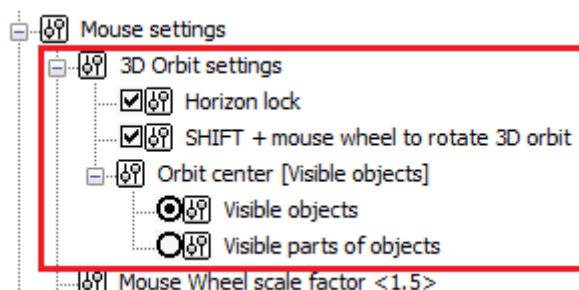

### Options:

#### Visible objects

Specifies the center of set of objects visible in the graphic area as the orbit rotation center. Thus, if only a part of circle is displayed on the screen, the rotation will be carried out around the center of this circle.

#### Visible parts of objects

Specifies the center of set of object parts visible in the graphic area as the orbit rotation center. Thus, if only a

part of circle is displayed on the screen, the rotation will be carried out around the center of the circle part visible on the screen.

## 3D-Navigation View Modes

### Perspective



Ribbon: **View – Navigate** >  **Perspective View**



Ribbon: **Point clouds – Navigate** >  **Prospective View**



Toolbar: **Views and projections** – 



Command line: **FITPERSPECTIVEVIEW**

Displays 3D-model in the perspective projection mode. When using **3D Walk** and **3D Fly** commands the mode starts automatically.

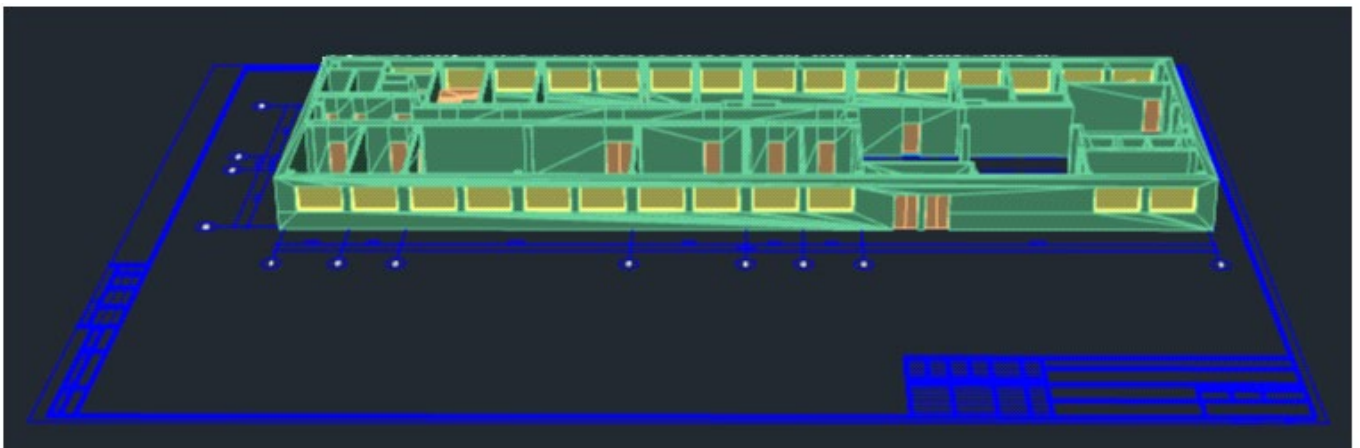

### Orthogonality



Ribbon: **View – Navigate** >  **Orthogonal View**



Ribbon: **Point clouds – Navigate** >  **Orthogonal View**



Toolbar: **Views and projections** – 



Command line: **FITORTOGONALVIEW**

Displays 3D model in orthogonal projection mode.

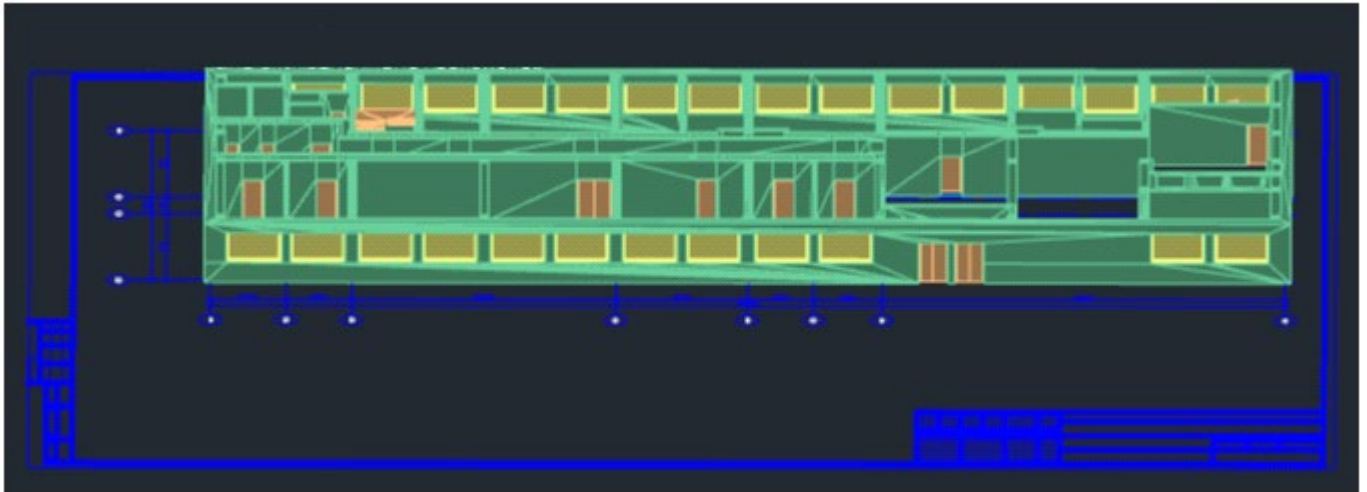

## Differences in Zooming in 3D-Projections

The result of scrolling the mouse wheel in a perspective projection differs from the work in a parallel one. While in a parallel projection the scale of display changes, which results in visual extension or compression of the visible area (analogue of Zoom+/- command), then in the perspective projection the viewpoint moves farther or closer from/to the nearest visible object, which is the analogue of **Fly** command (3DFLY).

Thus, scrolling the mouse wheel in a perspective projection allows you to “go through” all visible objects, in contrast to a parallel projection, where the same action will only lead to the change of display scale, i.e. visual “stretching” of the visual area.

In addition, the step of changing the display scale in a parallel projection, as well as the step of moving the camera in a perspective projection is calculated adaptively depending on the distance to the object under cursor, so that zooming/approaching to remote objects is faster, with adaptive step reduction while approaching. In case if the cursor projection along the camera line does not fall on any object, i.e. the cursor is “in emptiness”, the default step value is used, as it was in the previous version.

## 3D-Fly



Ribbon: **View – Navigate** >  **Fly**



Ribbon: **Point clouds – Navigate** >  **3D Fly**



Menu: **View – Walk and fly** >  **Fly**



Toolbar: **View toolbar** – 



Command line: **3DFLY**

Navigate 3D model in the perspective projection. You can change direction and height of moving.



After the command starts, the document window goes into fly mode and a perspective projection is set.

Cursor color changes to green. Top left corner displays current fly settings: walk step, coordinates of camera, coordinates of target. Command line displays inquire:

Fly or [waLk/eXit]:

walk option changes navigation to Walk mode (**3DWALK** command). exit option and **ESC** button finish the command.

Main direction of move in **3DFLY** command is forward to the target. Other available moves are relative to the forward: left, right, back, up, down.

To perform the fly, press and hold down the key corresponding to the desired direction. At the end of movement in one direction, you must release the pressed key and press the key corresponding to movement in the other direction.

**Used buttons:**

<b>UP</b> (on the main and numerical keyboard), <b>W</b>	Move up
<b>LEFT</b> (on the main and numerical keyboard), <b>A</b>	Move left
<b>RIGHT</b> (on the main and numerical keyboard), <b>D</b>	Move right
<b>DOWN</b> (on the main and numerical keyboard), <b>S</b>	Move down
<b>PAGE UP</b> , <b>Q</b>	Move up
<b>PAGE DOWN</b> , <b>E</b>	Move down
<b>+</b> (on the main and numerical keyboard)	Increase step
<b>-</b> (on the main and numerical keyboard)	Decrease step

While interrupting the movement, but remaining within the command, you can, by pressing the **+** or **-** keys once, increase or decrease the step (and, accordingly, the speed) of the movement

by half. The default initial step value is 1 mm. The minimum acceptable value is 0.0001 mm. If you change the step and save the drawing, next time the saved step value will be offered as the initial value in the **3DFLY** command.









Maximum step value is 1, minimum – 0.0001. Step value is saved with drawing. Press two buttons at the same time. For example, **UP** and **LEFT** to move in left-up direction.

To change the height, use Up and Down moving. To move camera without target, move mouse.

**NOTE:** Mouse wheel doesn't work as zoom.

When navigating directly inside 3D model objects, the model appears to be clipped by the front view plane.

## 3D-Walk

-  Ribbon: **View – Navigate** >  **Walk**
-  Ribbon: **Point clouds – Navigate** >  **3D Walk**
-  Menu: **View – Walk and Fly** >  **Walk**
-  Toolbar: **View toolbar** – 
-  Command line: **3DWALK**

Command is similar to **3DFLY**.

Navigate 3D model in the perspective projection parallel to z=0 plane in UCS. You can change direction of moving. You can change the height of moving for the following move on new height.

Started 3DWALK command sets perspective projection. Walk mode is similar to Fly mode, but step value is Walk step. Steps for Walk and Fly are the same.

Command line displays inquire:











Walk or [fLy/eXit]:

Fly option changes navigation to Fly mode (**3DFLY** command). Exit option and **ESC** button finish the command.

Working with **3DWALK** command is similar to working with **3DFLY** command in the current UCS.

## Plan

A plan view is a view aimed toward the origin (0,0,0) from a point on the positive Z axis in UCS or WCS. This results in a view of the XY plane.

-  Ribbon: **View – Coordinates** >  **Current UCS**
-  Ribbon: **View – Coordinates** >  **WCS**
-  Ribbon: **View – Coordinates** >  **Named UCS**
-  Menu: **View – Views – PlanView** >  **Current UCS**
-  Menu: **View – Views – PlanView** >  **WCS**



 Menu: **View – Views – PlanView >**  **Named UCS**

 Command Line: **PLAN**

You can select current UCS, named UCS or WCS

**Options:**

- Current UCS Changes the view to XY plane in current UCS. Used by default
- UCS Changes the view to XY plane in saved UCS. You will be asked for the name of the saved UCS.
- WCS Changes the view to XY plane in the WCS.

The **Plan** command changes view, but doesn't change current UCS. All coordinates entered or displayed after running the command are counted relative to the current UCS.

## View Cutting Planes

 Ribbon: **View – Navigate >**  **SecantPlanes**

 Ribbon: **Point clouds – Navigate >**  **SecantPlanes**

 Toolbar: **Navigate >**  **SecantPlanes**

 Command line: **DVIEW**

For a view you can set front and/or back clipping planes that hide all objects located outside the space between these planes. The position of clipping planes is regulated by sliders moving them closer or farther from the point of view.

**NOTE:** View clipping planes are not drawing objects, but are display parameters (conditions).

**Command options:**

- Front Displays a slider at the top of the workspace that allows you to adjust the position of the front clipping plane. The back clipping plane is not specified (i.e., it is assumed to be at an infinite distance from the point of view).
- Back Displays a slider at the top of the workspace that allows you to adjust the position of the back clipping plane. The front clipping plane is not specified (i.e., it is assumed to be the same as the screen plane).
- Both Displays a slider at the top of the workspace that allows you to adjust the position of both the front and back clipping planes.
- Off The option is available when the command has already been called earlier and the clipping planes have been set. Hides a slider at the top of the workspace and turns off clipping planes.

**Command prompts:**

Select clipping plane or [Front/Back/Both/Off]: Specify the required option.

After starting the command and selecting the desired mode for specifying the clipping planes, you should adjust the position of these planes by moving the slider grips in the upper part of the

workspace. Initially, the front plane is located at the point of view, and the back one at the maximum distance.

*Display mode for both clipping planes. The position of planes is not adjusted:*

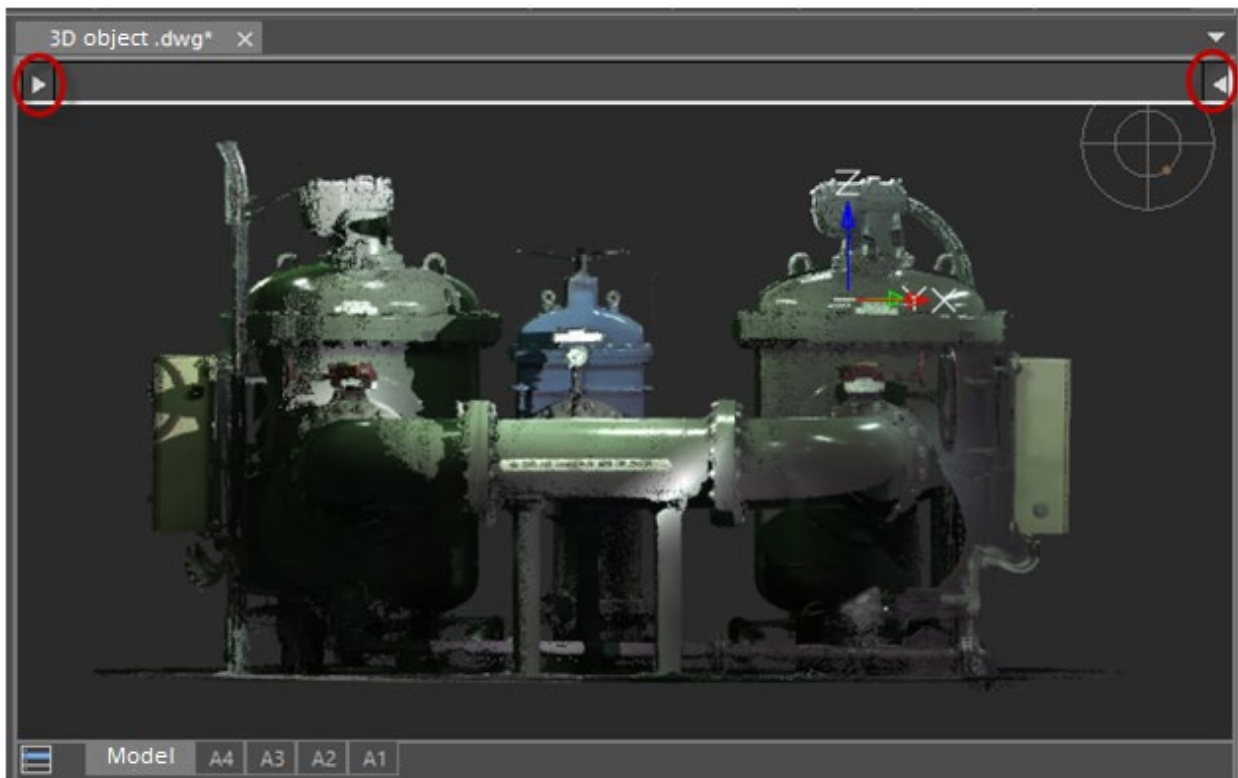

*Moving the front clipping plane away from the viewpoint while clipping the front objects:*

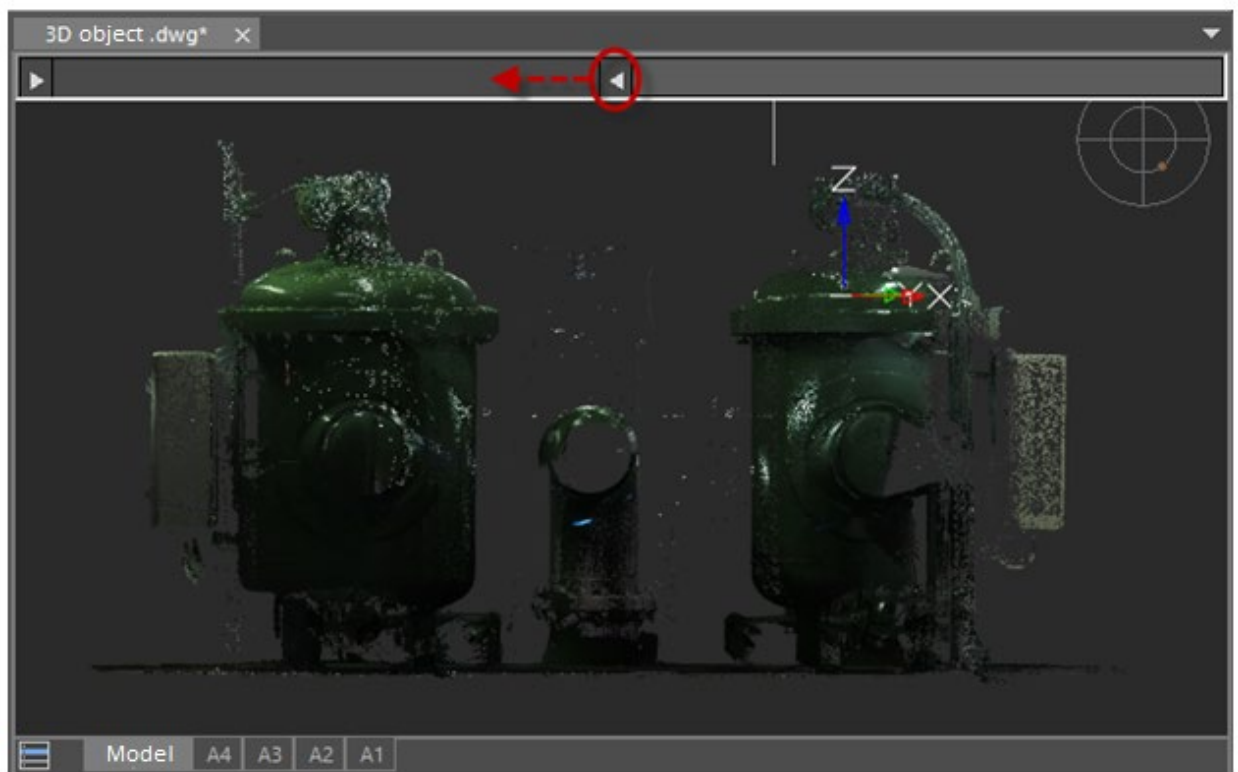

*Moving the back clipping plane towards the point of view while clipping off the background objects:*

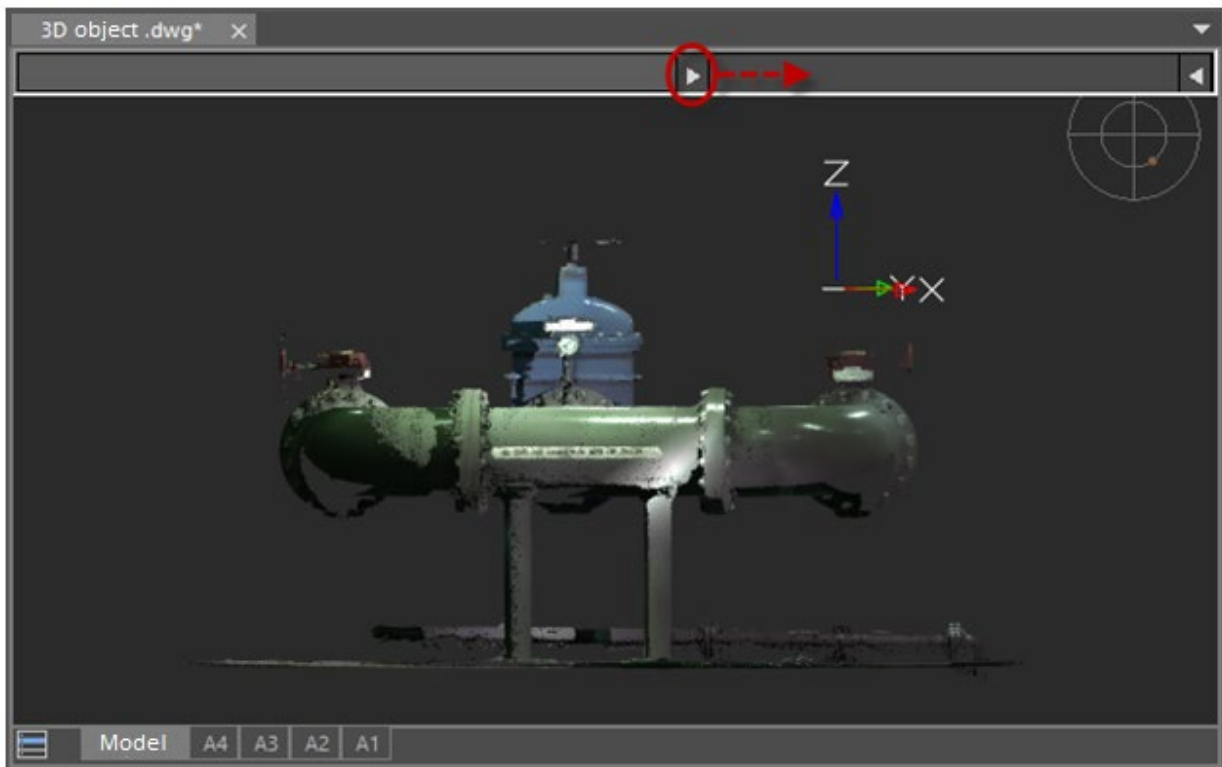

## Viewport Tools for Views Management

### Locator

*Locator* is a visual tool that can be used both in 2D model space and in 3D navigation, it allows you to:

- quickly identify the current orientation of a view (by the position of the orange marker point and the name of the view at the bottom of the locator);
- switch between orthographic, intermediate and isometric views (by clicking on the locator elements);
- set any arbitrary view (by clicking on the locator while holding down **CTRL** key).

The display of *Locator* and *View control* tools on the screen is managed through the menu of  sign

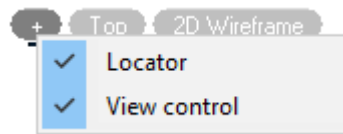

When opening a document or working with drawing elements, the **Locator** is inactive and shows the current position of the view with the dot mark . The view name is translated in the tooltip below.

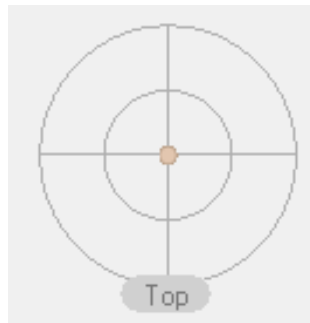

When you hover the cursor, the tool becomes active.

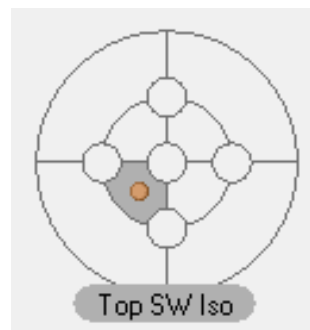

Each Locator element is responsible for setting a particular view.

The diagram below shows the location of vertices of *orthographic* views on the locator. Vertices are connected by edges of *intermediate* view. Zones of *isometric* views are located between these edges (light gray sectors in the diagram).

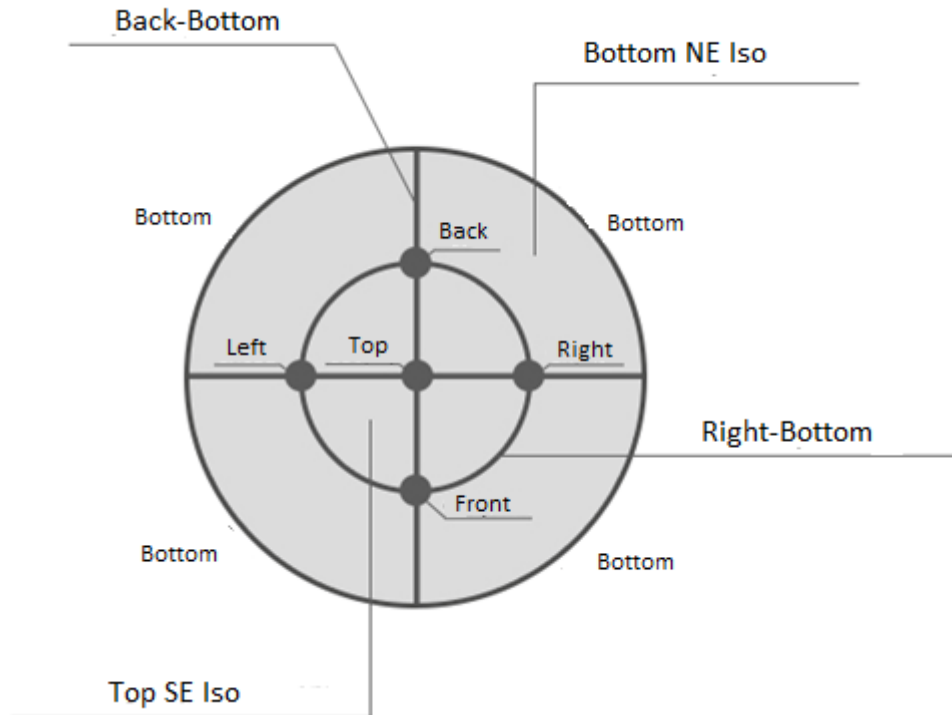

For example, knot circles serve to install orthogonal views, edges – intermediate views, and segments – isometric ones.

### Setting an arbitrary view

In addition to the preset views, the locator allows you to set any desired view. To do this, click to select the desired position on the locator while holding down the **CTRL** key. The orange marker  will be positioned exactly at the specified location, not just in the center of the locator zone. Below is the result of a normal click and click using **CTRL**.

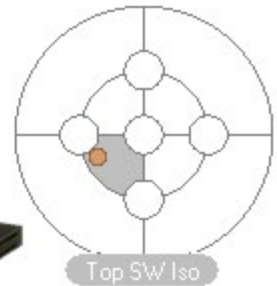
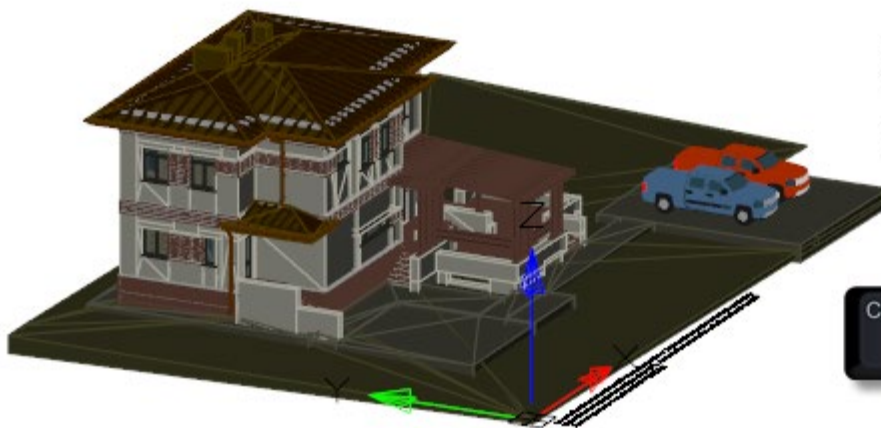
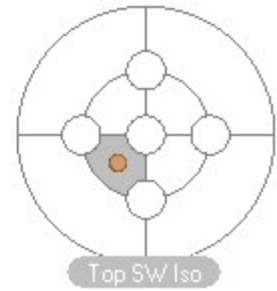
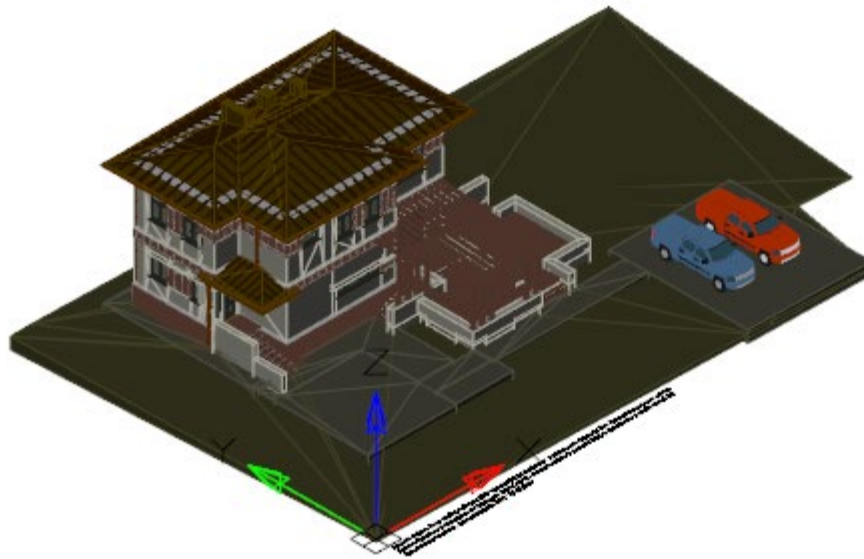

### View rotation mode

When you hover the cursor over the locator with the **ALT** key pressed, it changes its appearance and switches to the view rotation mode. The mode allows you to rotate the current view around the axis of the viewing direction. In other words, it is possible to rotate the view clockwise or counterclockwise in the plane of the current view.

For example, an arbitrary view is displayed.

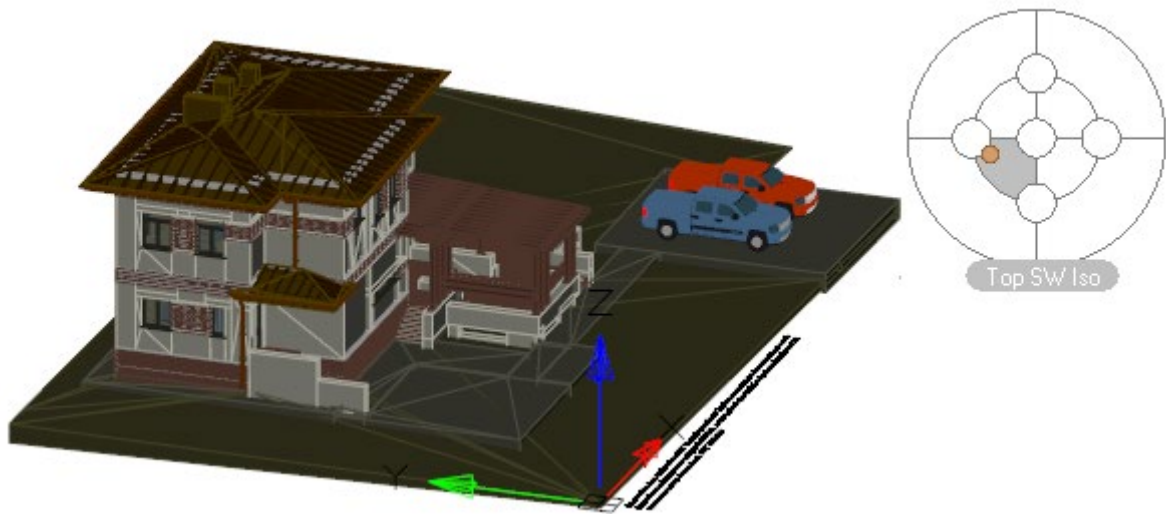

When you move the cursor over the locator and hold down the **ALT**, the locator will change its appearance.

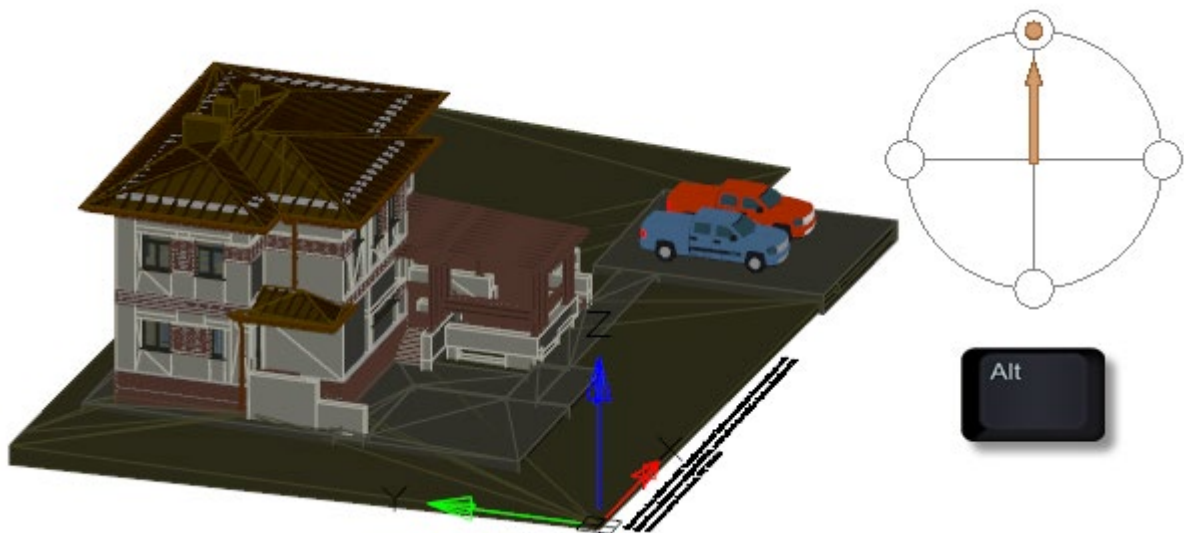

Click on the locator while holding **ALT** will turn the view to the specified position. The arrow position indicates the current rotation position of the view.

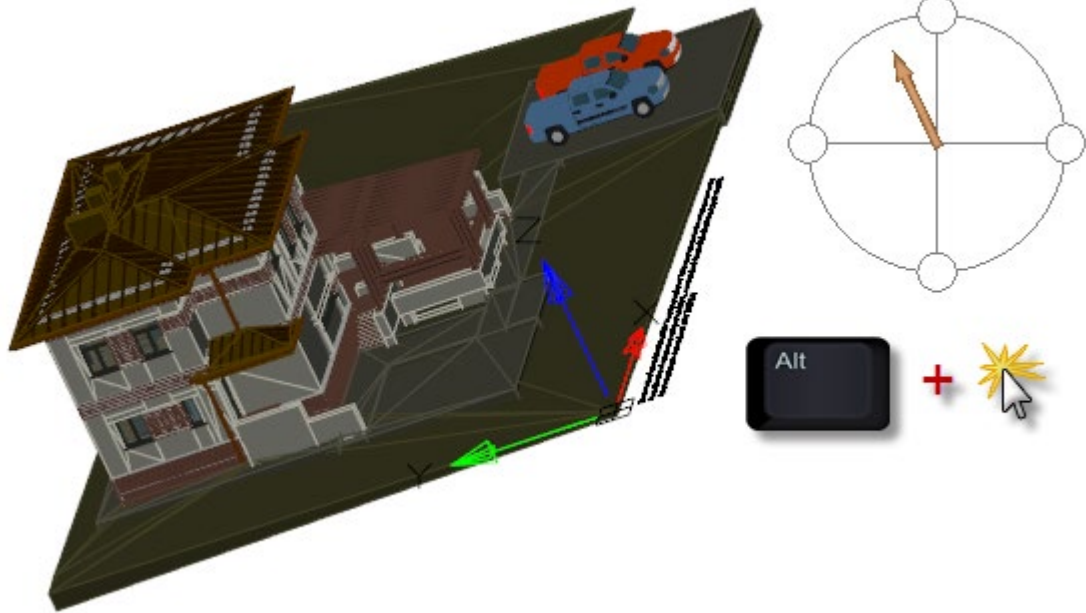

For accurate rotation for 90 degrees, click on one of the four circles on the locator edges.

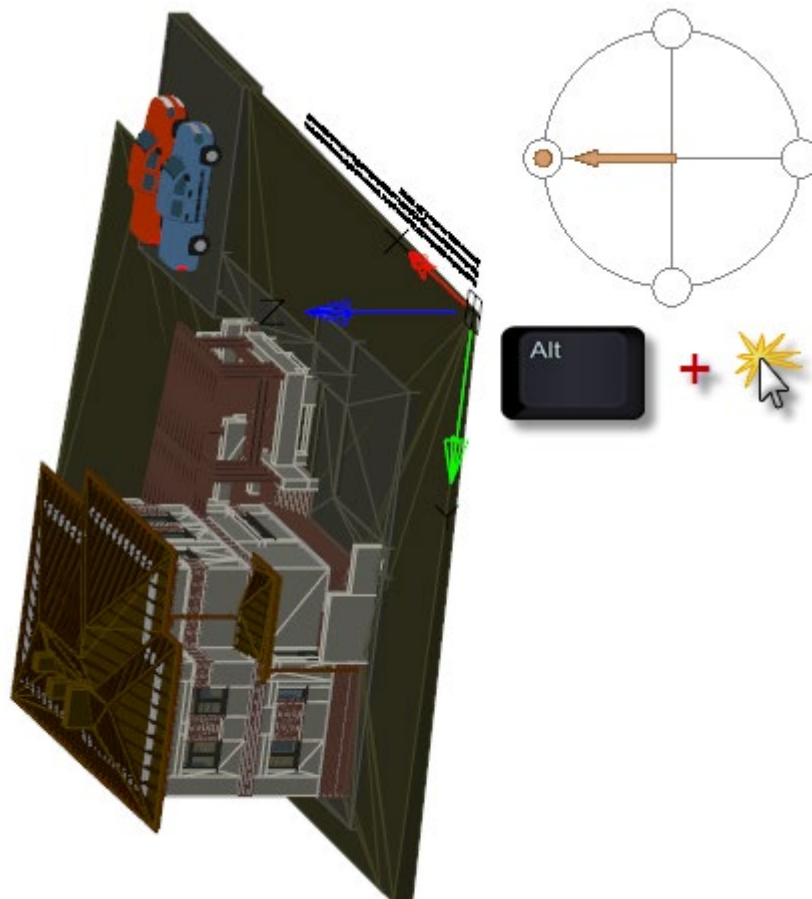

After releasing the **ALT** key, the locator will return to its normal state.



### LOCATORORIENT system variable

The LOCATORORIENT system variable allows you to control the mode to set the current (custom or default) view of model space.

If the value of the system variable is 1 (UCS view orientation), then when you switch to the UCS, the view orientation changes in accordance with the direction of the axes of the current user coordinate system, which is reflected by the position of the locator marker (orange dot).

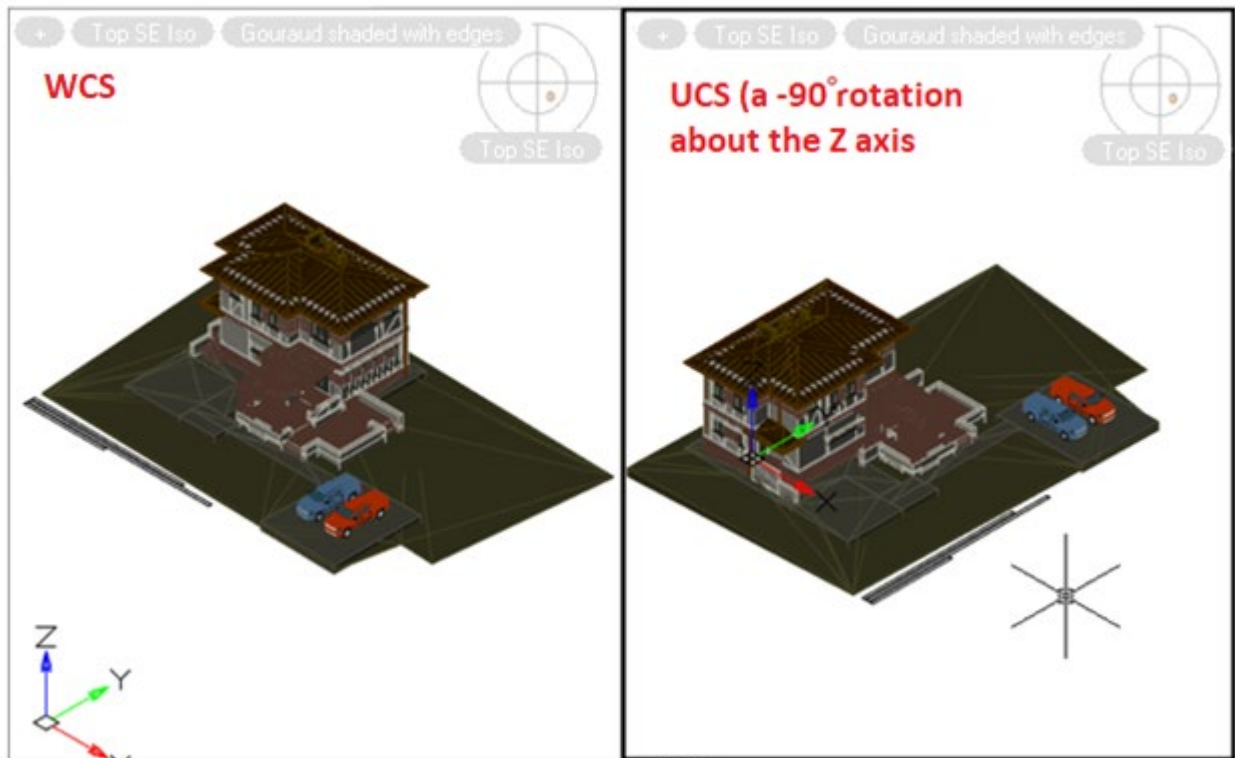

If the value of the system variable is 0 (corresponds to the orientation of the view according to the WCS), then when switching to the UCS, the orientation of the view will be determined relative to the world coordinate system.

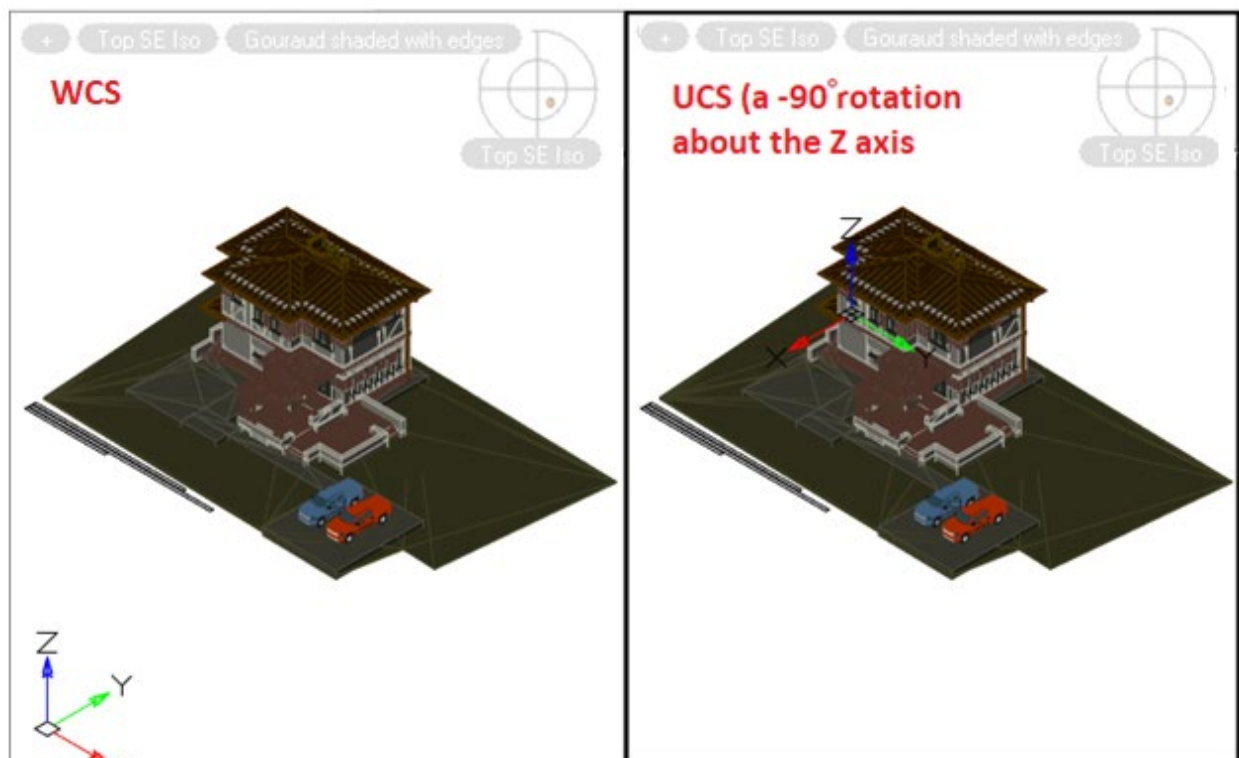

The action of the system variable applies only to setting custom views using the locator and from the context menu of the **View control**.

The action of the variable does not apply to setting views using the VIEW command, toolbars, calls from the ribbon and from the menu.

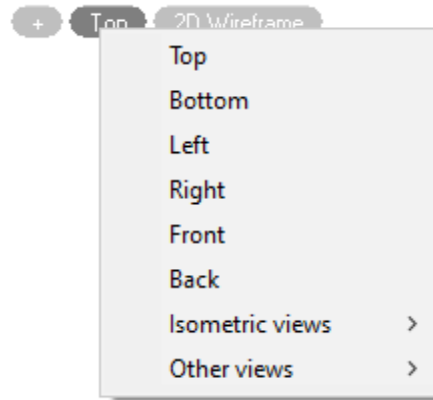

## Managing display of line weight on the screen

Line weight (width) is a width assigned to graphic primitives. Line weight allows to get thin and thick lines when creating a drawing.

Line weight is differently displayed in paper space and in model space.

Displaying in model space:

Line of a 1 pixel width corresponds to 0 line weight in model space. Display widths in pixels of other line weights are set proportionally to their values and do not depend on zooming in or out on the screen. For example, if a line weight is 4 pixels, primitives having such line weight are displayed with 4 pixel width on the screen, even though they are zoomed in.

Displaying in paper space:

Displayed in paper space line width of primitives is always the same as their line weights. That is why when a paper space list is zoomed, displayed width of primitives is changed.

To turn on/off display of line weights on the screen use the **SW** in the status bar.

Primitives having a width more than one pixel increase a regeneration time of drawing; productivity of program decreases if display of line weights is on. It is recommended to switch off the display of line weights. It does not affect displaying line weights (widths) when you print a drawing.

You can change a scale of line weights display for primitives in model space.

### Lineweight Settings Dialog



Menu: **Format** –  **Line weight...**



Status bar: Context menu of the **SW** button –  **Settings...**



Command Line: **LINEWEIGHT**

The command opens the **Lineweight Settings** dialog box to set the lineweight current value and measurement units, to control the lineweights display and scale, as well as to select the **Default** lineweight value for layers.

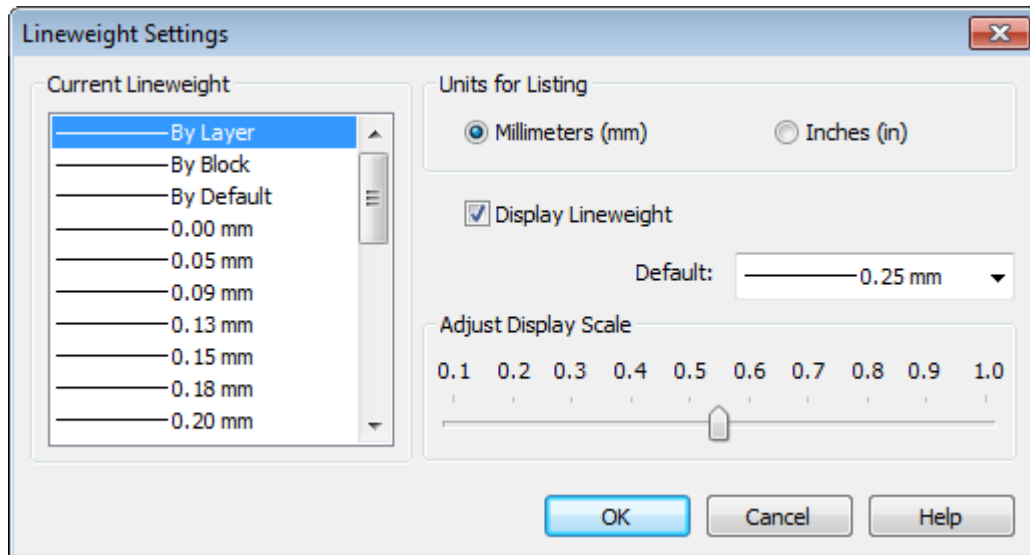

**Options:**

*Current Lineweight*

List of standard lineweights.

Select from list of standard lineweights or special values **By Layer**, **By Block** or **By Default**. **By Default** value is defined by **LWDEFAULT** system variable. For all new layers lineweight is set **By Default**.

*Units:*

**Millimeters (mm)**

Sets lineweight units to millimeters.

**Inches (in)**

Sets lineweight units to inches.

*Display Lineweight*

Switches On/Off displaying lines according to their lineweights.

*By Default*

Sets **By Default** value for new layers (**LWDEFAULT** system variable).

*Adjust Display Scale*

Sets lineweight display scale in **Model** space (**LWDISPLAY** system variable). **LWDISPLAY = 0** switch off show lineweight and **LWDISPLAY = 1** is real-unit value .

**NOTE:** Using lineweight width that is more than one pixel may slow down performance on display regeneration. To speed up work in Model space you can decrease **Adjust Display Scale** setting or switch off **Display Lineweight**. Lineweights are always plotted at their real value whether their display is turned on or off.

## Managing Named Views

When you perform a project, you often have to work with different fragments of a document. Navigation commands in the document (zooming and panning) and tools used to switch from model space to paper space and back are often used. You can save fragments of the document which are frequently used as named view. Named views allow you to switch between one part of the document to another.

 Ribbon: **View – Views >  Set View**

 Menu: **View –  Named Views**

 Command line: **VIEW, -VIEW**

 Hot keys: **ALT+E**

The command allows creating, restoring and deleting named views from the model space and paper space.

After the command is started, the prompt of available options is shown in the command line:

Enter an option [?/Delete/Orthographic/Restore/Save/Settings/Window]:

**Command options:**

? Displays named views in the document.  
Option starts the following prompt in the command line:  
Enter view name(s) to list <\*>:  
Asterisk symbol (\*) is set in the angle brackets by default, it means that when you press the **ENTER** a full list of named views is displayed in the command line:

Saved views:

View name	Space
View 1	M
View 2	M
View 3	M
View 4	L
View 5	L

The M letter means that named view is in the model space and L letter in paper space.

Delete Deletes named view.

Orthographic Selects standard orthogonal view.

The option starts the following prompt in the command line:  
Enter an option [Top/Bottom/Front/Back/Left/Right] <Top>:

**Options:**

- Top - Sets top view.
- Bottom - Sets bottom view.
- Front - Sets front view.
- Back - Sets back view.
- Left - Sets left view.
- Right - Sets right view.

Restore Restores the view (selected view is displayed on the screen).

Save Sets a name to the current view, displayed on the screen.

Settings Specifies the display properties of restored named view.  
The option starts the following prompt in the command line:  
Enter an option [BackGround/Categorize/Layer Snapshot/Live Section/UCS/Visual style]:

**Options:**

BackGround – Redefines background for view of model space, which does not have “2D Frame” value of visual style.

Categorize – Displays view category, specified in the drawing (for the views of model and layouts).

Layer Snapshot – Defines switch on/off parameters of the current view to be saved or not, with the named view (for the views of model and layouts).

Live Section – Displays live section used when the view is restored (only for model views)

UCS - Defines UCS to be saved or not, with the named view (for the views of model and layouts).

Visual style – Defines a visual style to be saved with view (only for model views)

### Window

Creates a new named view by specifying opposite corners of the rectangular area on the screen.

#### **To save a current view:**

*Command prompts:*

Enter an option  
[?/Delete/Orthographic/Restore/Save/Settings/Window]:

Select option Save.

Enter view name to save:

Enter a view name and press **ENTER**.

#### **To save several views at once:**

*Command prompts:*

Enter an option  
[?/Delete/Orthographic/Restore/Save/  
e/  
Settings/Window]:

Select option Window.

Specify first corner:

Specify first corner of the rectangular area of the first view.

Specify opposite corner:

Specify opposite corner of the rectangular area of the first view.

Enter view name to save:

Enter a name of the first view and press **ENTER**.

Specify first corner:

Specify first corner of the rectangular area of the second view.

Specify opposite corner:

Specify opposite corner of the rectangular area of the second view.

Enter view name to save:

Enter a name of the second view and press **ENTER**.

Specify first corner:

Specify first corner of the rectangular area of the following view or press **ESC** to finish the command.

**NOTE:** After the view name is specified the image is autopanned to display a created named view on the screen.

**To restore (display on the screen) a named view:**

*Command prompts:*

Enter an option  
 [?/Delete/Orthographic/Restore/Save/Settings/Window]:

Select an option Restore.

Enter view name to restore:

Enter a name of the view.

To switch quickly between the view use the  button at the end of the layouts tab bar. Click on it and the context menu displaying all existing layouts tabs and named views in the document is shown:

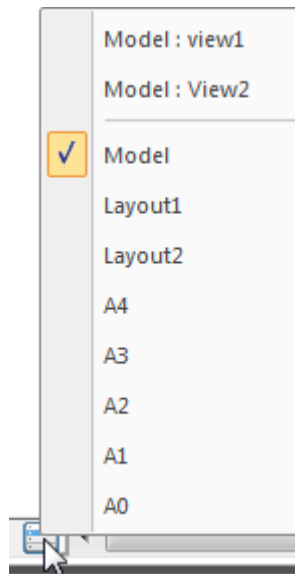

There are named views in the top part of the menu and layout tabs in the bottom part. Named views of the model are marked with **Model:** prefix, named views of the layout are marked with a prefix of the corresponding layout's name (*Layout1:*, *Layout2:*, *A4:* etc.). The current tab is marked with  sign. Click on the corresponding menu item to switch to the required named view.

**To delete a named view:**

*Command prompts:*

Enter an option  
 [?/Delete/Orthographic/Restore/Save/Settings/Window]:

Select an option Delete.

Enter view name(s) to delete or [view1/view 2/view 3/view 4]:

Select a view name to be deleted.

The selected view name is deleted from the list of named views just after you click.

Enter view name(s) to delete or [view1/view 2/view 4]:

Select the name of the following view to be deleted or press **ESC** to finish the command.

## Order of Objects

When editing a document, the objects are shown in the order that they were created. Some objects can be overlapped or obscure each other. To correct the situation, the order of the objects (their display on the screen) can be changed, one object can be placed in front of another.





Commands to change the order of objects allow you to regulate the display of overlapping objects in one plane.

**NOTE:** it is not possible to set a common order of objects for the model space and paper space: the order is set separately on each tab.

The **Draworder** command controls the order of drawing all objects. After running it, a prompt is displayed in the command line:

Enter object ordering option or [Above objects/Under objects/Front/Back]:

Commands to change the order of objects are shown in the **Tools – Display Order** and on the **Display Order** toolbar:

-  [Bring to Front](#);
-  [Send to Back](#);
-  [Bring Forward](#);
-  [Send Backward](#).



In addition to **Display order** command the **Objectorder** command can change draw order for such objects as text, dimensions and hatches.

**ATTENTION!** The **Objectorder** command does not work with text objects, dimension objects and hatches that are included in blocks and external references. Work with the leader text and the table text is also not supported by this command.

After running the command, a prompt is displayed in the command line:

Select an option [TT/DT/TDI/HB]:

Commands to change the order of text, dimension and hatch objects are shown in the **Tools – Display Order** and on the **Display Order** toolbar:

-  [Texts to front](#);
-  [Dimensions to front](#);
-  [Texts and dimensions to front](#);

The command to change the display order of hatches: in the menu **Tools – Display order >**

 [Hatches to back](#).

The version of the **Purge document** command to work from the command line (-PURGE) allows you to clear the object sorting table. The sorting table contains lists of the order of the objects. Sometimes there are so many such records that the program starts working with the document much slower. Purging this list removes empty entries, greatly speeding up your work.

## *Bring to Front*

 Menu: **Tools – Display Order >  Bring to Front**

 Toolbar **Display Order** – 

 Command line: **DR, DRAWORDER, DRAWORDER1**

Forces the selected object to be displayed in front of all other objects.

## *Send to Back*

 Menu: **Tools – Display Order >  Send to Back**

 Toolbar: **Display Order** – 

 Command line: **DR, DRAWORDER, DRAWORDER2**

Forces the selected object to be displayed behind all other objects.

## *Bring Forward*

 Menu: **Tools – Display Order >  Bring Forward**

 Toolbar: **Display Order** – 

 Command line: **DR, DRAWORDER, DRAWORDER3**

Forces the selected object to be displayed in front of the object located in front of it.

## *Send Backward*

 Menu: **Tools – Display Order >  Send Backward**

 Toolbar: **Display Order** – 

 Command line: **DR, DRAWORDER, DRAWORDER4**

Forces the selected object to be displayed behind the object located beneath.

## *Bring Texts to the Front*

 Menu: **Tools – Display Order > Bring to Front Only  Texts**

 Toolbar: **Display Order** – 

 Command Line: **TEXTTOFRONT**

Change draw order for all texts in the drawing or all texts from selection to the **Front**.



## *Bring Dimensions to the Front*



Menu: **Tools–Display Order > Bring to Front Only >  Dimensions**



Toolbar: **Display Order – **



Command Line: **TEXTTOFRONT**

Change draw order for all dimensions in the drawing or all dimensions from selection to the **Front**.

## *Bring Texts and Dimensions to the Front*



Menu: **Tools– Display Order > Bring to Front Only >  Text and Dimensions**



Toolbar: **Display Order – **



Command Line: **TEXTTOFRONT**

Change draw order for all dimensions and texts in the drawing or all dimensions and texts from selection to the **Front**.

## *Send Hatches to the Back*



Menu: **Tools– Display Order >  Hatches to the Back**



Toolbar: **Display Order – **



Command Line: **TEXTTOFRONT**

Change draw order for all hatches and fills in the drawing or all hatches and fills from selection to the **Back**.

## *Control the Objects Visibility*

### *Objects Isolation*

The isolation commands control the visibility of objects by isolating or hiding a selection set. Use **ISOLATEOBJECTS** and **HIDEOBJECTS** to create a temporary drawing view with selected objects isolated or hidden.

The commands are used to create a temporary view of the document when you need to hide the selected objects, or isolate - leave visible only the selected objects, hiding all others.

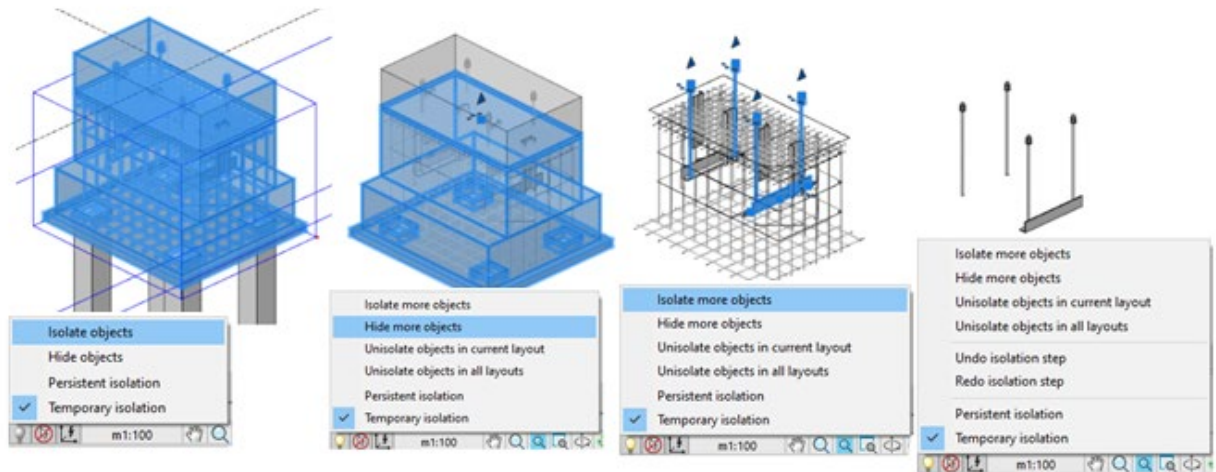

The commands for controlling the display of objects are located in context menu and **Tools – Isolate Objects** menu:

-  [Isolate Objects](#)
-  [Hide Objects](#)
-  [Undo isolation step](#)
-  [Redo isolation step](#)
-  [Unisolate objects](#)

**NOTE:** Isolation and its undo is independent of the general undo-redo mechanism (UNDO/REDO). For example, you can isolate a set of objects, edit them, and then roll the isolation back to a previous visibility state. In this case, all changes for the edited objects will remain.

Control the display of objects placed in the menu of  Toggle Isolate button in status bar.

**Isolate objects mode:**

- |                             |   |
|-----------------------------|---|
| <b>Persistent isolation</b> | Selected objects stay hidden or isolated after save, close and reopen of drawing. |
| <b>Temporary isolation</b>  | Selected objects are isolated or hidden in the current program session.           |

Button form and menu composition depends on the presence of hidden and isolated objects:

 - there are no hidden and isolated objects in the drawing.  
Available functions:

- Isolate objects**
- Hide objects**

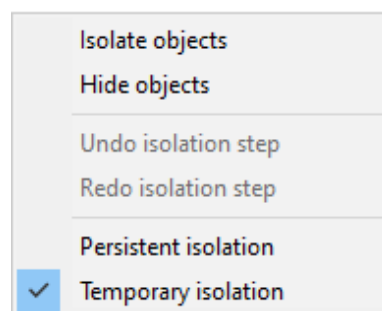

 - there are hidden and isolated objects in the drawing.

Available functions:

**Isolate more objects**

**Hide more objects**

**Unisolate objects in current layout**

**Unisolate objects in all layouts**

**Undo isolation step**

**Redo isolation step**

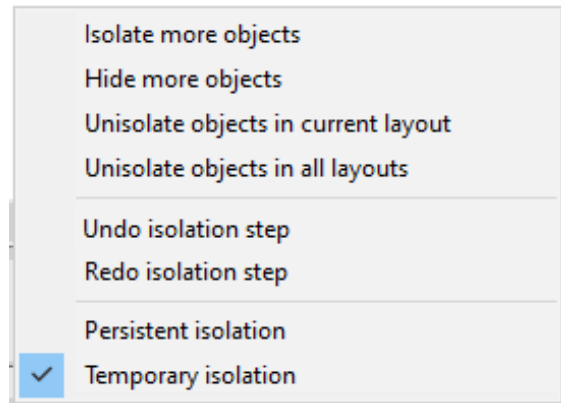

## Isolate Objects

 Ribbon: **View – Visibility Manager** >  **Isolate Objects**

 Menu: **Tools – Isolate Objects** >  **Isolate Objects**

 Status bar:  **Isolate Objects** > **Isolate objects**

 Command Line: **ISOLATEOBJECTS**

If you isolate objects, only the isolated objects appear in the view.

## Hide Objects

 Ribbon: **View – Visibility Manager** >  **Hide Objects**

 Menu: **Tools – Isolate Objects** >  **Hide Objects**

 Status bar:  **ToggleIsolate** > **Hide Objects**

 Command Line: **HIDEOBJECTS**

Hide selected objects.

## Undo Isolation Step

 Ribbon: **View – Visibility Manager** >  **Undo isolation step**







 Menu: **Tools – Isolate objects** >  **Undo isolation**

 Status bar:  **ToggleIsolate** > **Undo Isolation Step**

 Command line: **UNDOISOLATION**

Successive undo f actions to isolate or hide objects..

## Redo Isolation Step

-  Ribbon: **View – Visibility Manager** >  **Redo isolation step**
-  Menu: **Tools – Isolate objects** >  **Redo isolation**
-  Status bar:  **ToggleIsolate** > **Redo Isolation Step**
-  Command line: **REDOISOLATION**

Successive redo of undone steps of isolating or hiding objects.

## Unisolate Objects







-  Menu: **Tools – Isolate Objects** >  **Unisolate Objects**
-  Command Line: **UNISOLATEOBJECTS**

Command to redisplay the hidden objects.







You can unisolate objects in all drawing layouts or only in the current layout by selecting the required option in the command line:

Unisolate objects [in\_All\_layouts/in\_Current\_layout/] <in\_Current\_layout>:You can choose option to cancel objects isolation on the **Isolate objects** toolbar and on the ribbon – **View** tab – **Isolate** group:









*Turns on visibility of earlier isolated or hidden objects in the current layout*

-  Ribbon: **View – Visibility Manager** >  **Unisolate objects in current layout**
-  Toolbar **Isolate objects**: 
-  Status bar:  **ToggleIsolate** > **Unisolate objects in current layout**

*Turns on visibility of earlier isolated or hidden objects in all layouts*

-  Ribbon: **View – Visibility Manager** >  **Unisolate objects in all layouts**
-  Toolbar **Isolate objects**: 
-  Status bar:  **ToggleIsolate** > **Unisolate objects in all layouts**

## Bounding Prism

-  Ribbon: **View – Visibility Manager** >  **Bounding Prism**
-  Menu: **View** >  **Bounding Prism**
-  Menu: **Modify – Clip** >  **Bounding Prism**
-  Toolbar: **View toolbar** >  **Bounding Prism**



Command line: **MCLIP**

For each model or paper space viewport, you can create a bounding prism – an area in a three-dimensional space, beyond which all the graphics are not displayed.

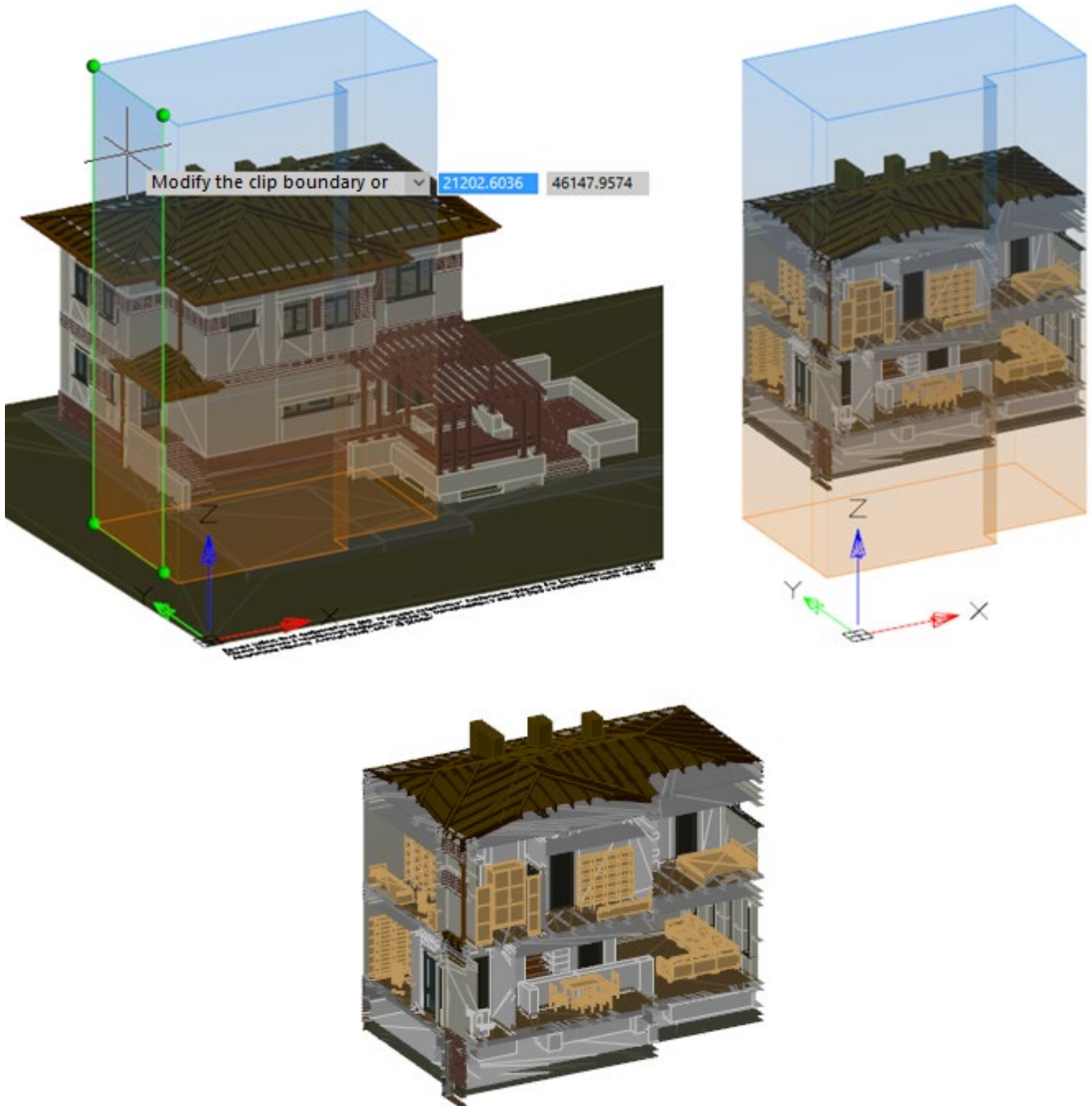

The area is defined as a rectangular or polygonal object. The prism can be created by specifying a contour on the screen, on the basis of an existing polyline, based on a bounding box of selected objects. The prism can be stretched, compressed, and resized by dragging any edges and faces in any place.

So, you can grab any area of the visible face and move it along its normal (in the case of a rectangular prism) or in any direction (in the case of a polygonal prism). Snaps and orthographic drawing modes can be used. Hidden faces can be moved by grabbing one of their edges. The entire prism can be dragged while holding down **CTRL**.

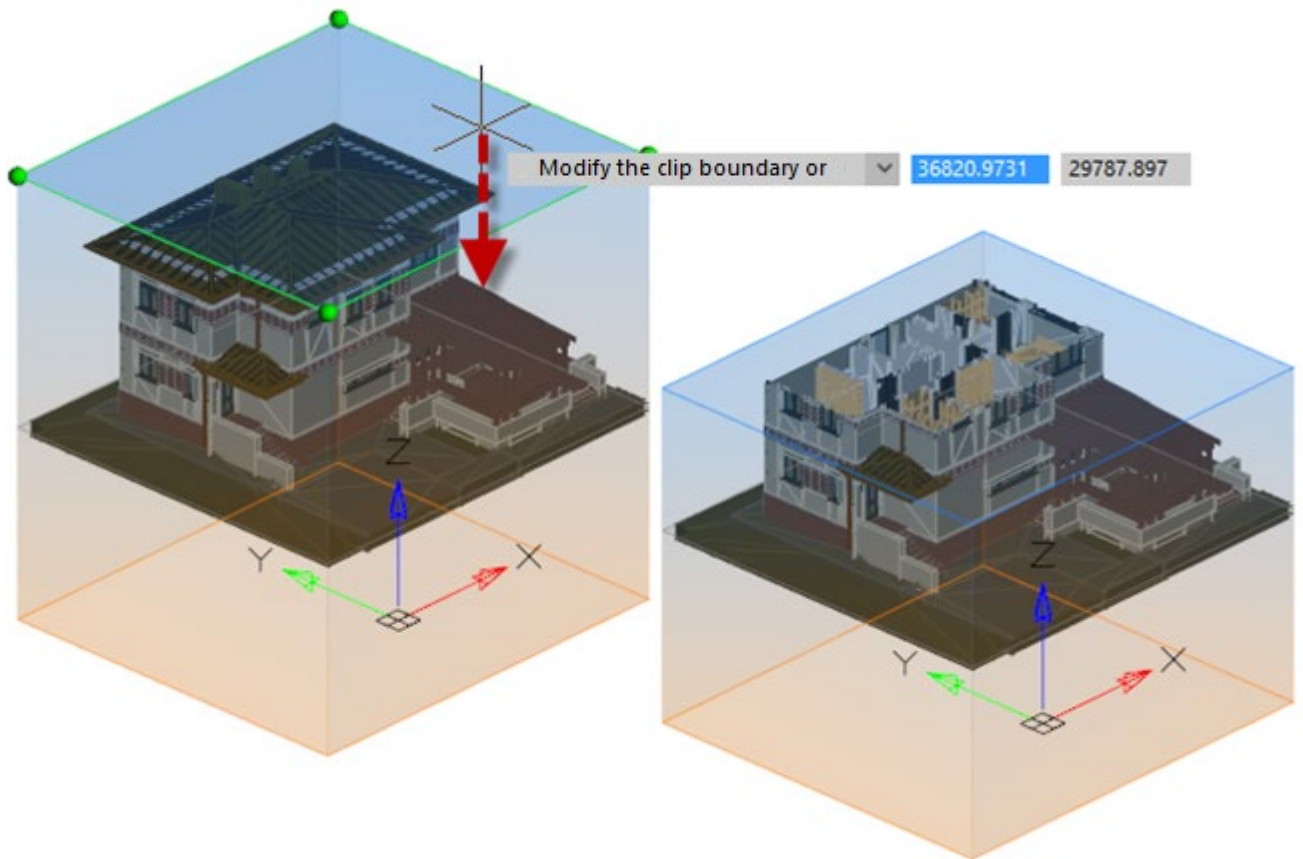

The prism is built taking into account the direction of the UCS axes. The prism above the XY plane of the UCS is blue, below it is orange. The grey outline of the prism is displayed in the XY plane.

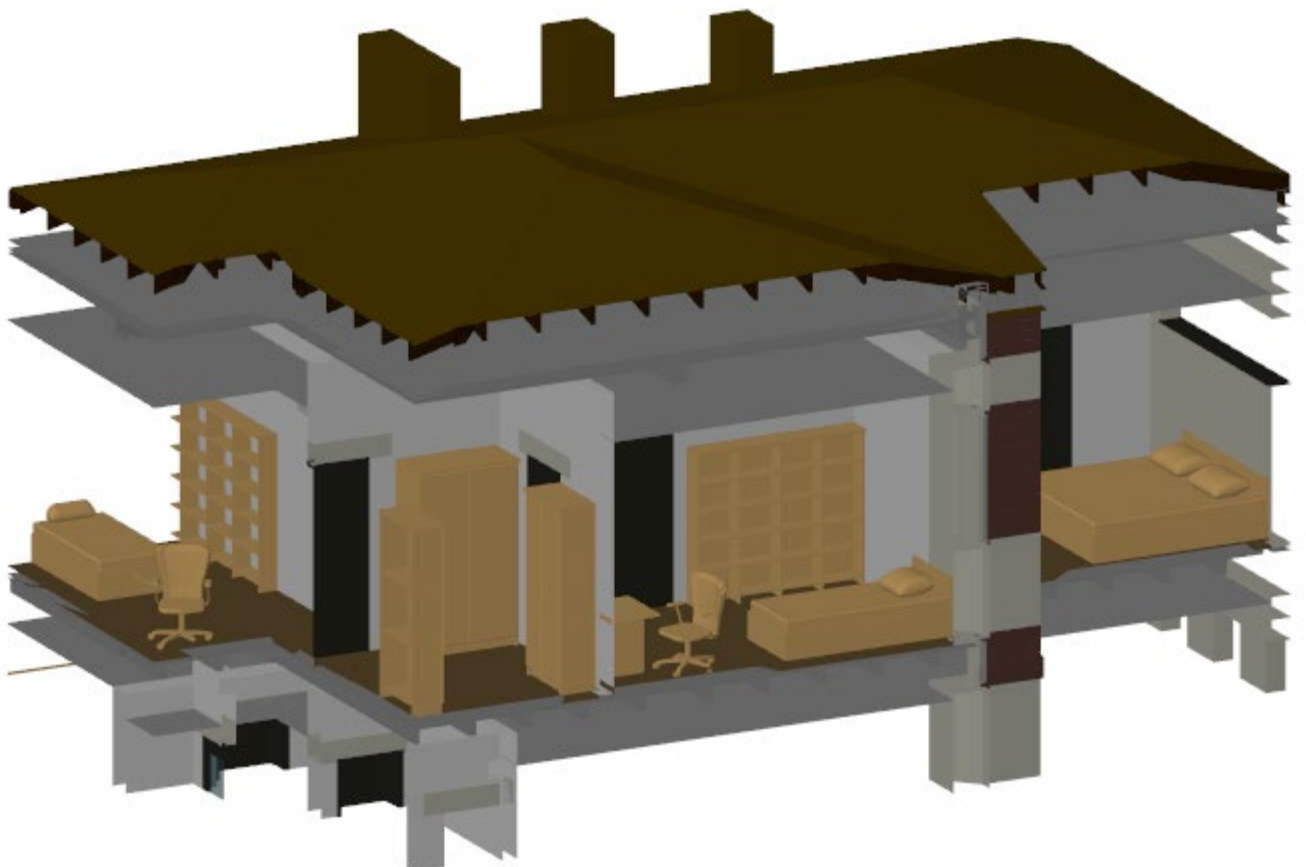

A bounding prism is created for each viewport. It will not restrict the image in other viewports.

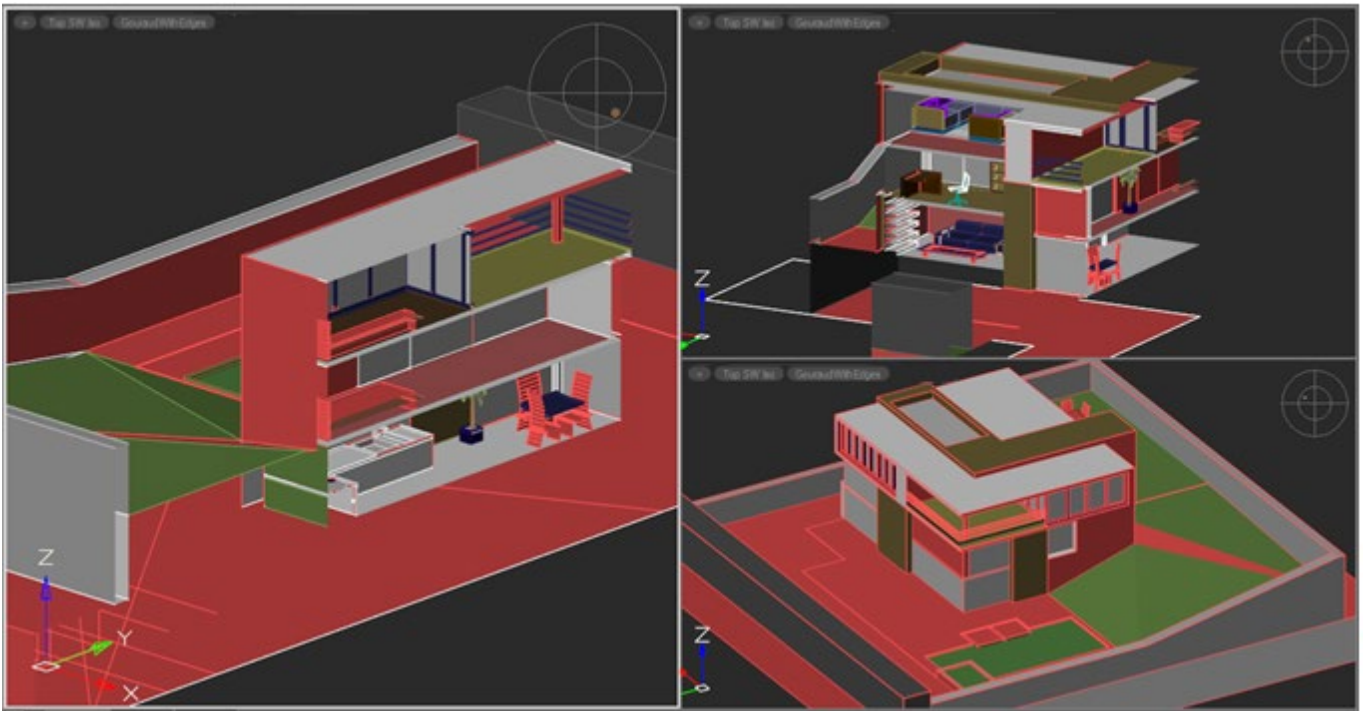

At the time of creating or editing a prism, it is displayed in all viewports, but its effect only applies to the screen in which it was created or was selected for editing. When you finish adjusting the prism, it will crop the image only in the viewport for which it was created.

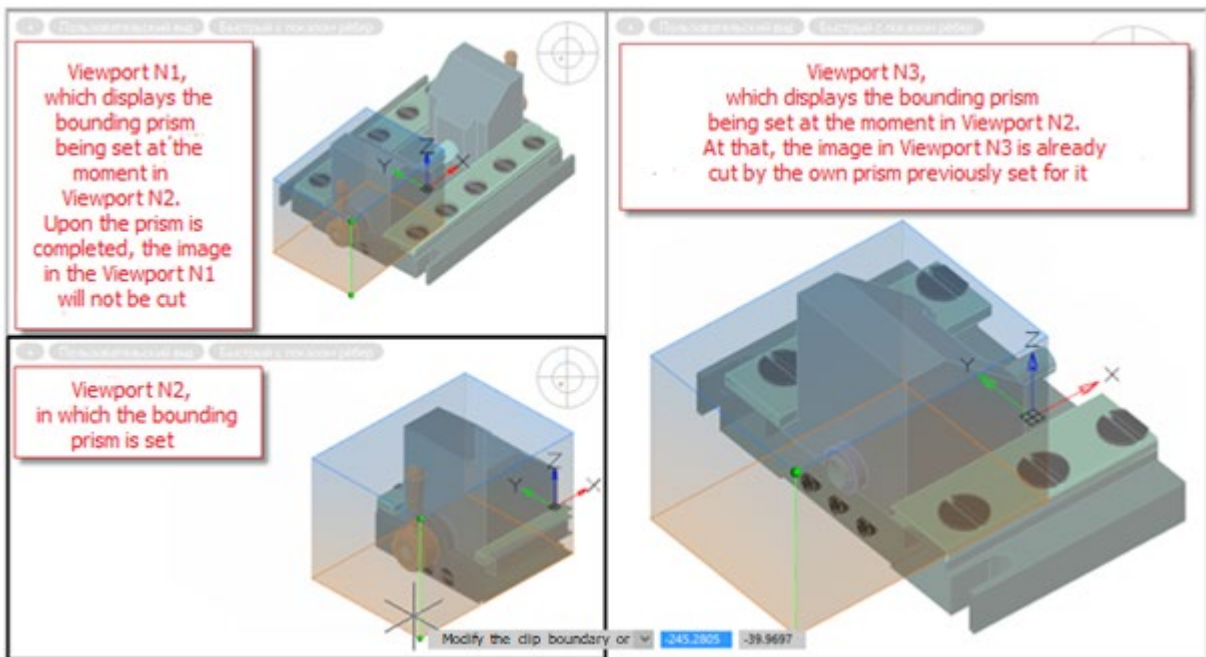

To create a new or edit an existing prism, go to the desired viewport and run the **Bounding prism** command.

While editing a prism, you can switch to another viewport to continue editing it from a more comfortable angle. At the same time, editing of the prism that belongs to the previous viewport (in which the Bounding Prism **Bounding prism** command was run) will continue in the new viewport, and not the current one. A prism in its own viewport is displayed more vividly than in the others so that it is always clear which viewport it belongs to, regardless of which viewport is currently active.

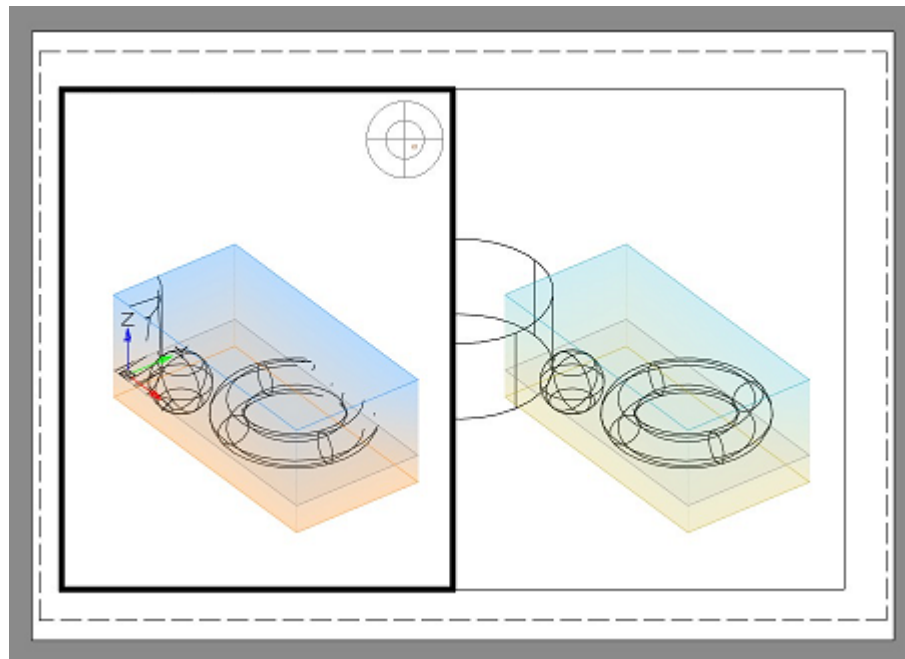

When saving a document, prisms are also saved for their viewports.

An existing prism can be changed, deleted or disabled/enabled. If the prism is disabled, graphics outside the prism become visible. Disabled prism object is still present in the model space and can be switched on later.

### **Options:**

- New                      Creates a new bounding prism for the current view of the model space.
- Delete                      Deletes the existing bounding prism in the current view of the model space.
  
- Enable                      Activates the effect of an existing prism on the current view of the model space. Enabled by default.
- Disable                      Inactivates the effect of an existing prism on the current view of the model space. Prism is preserved, but does not limit the space of the view.
- Exit                          Exits command.

### **Options for creating a new prism:**

Options appear when there is no prism in the viewport or when **New** option is selected.

- polyLine                      Selects an existing closed polyline that will define the contour of the prism. Then, using grips, set the upper and lower prism cutoff boundary, if necessary. The prism will be built in the direction of the UCS axes of the current view.
- Selection                      Selects the objects around which a rectangular prism will be built. Then, using grips, change the upper and lower prism cutoff boundary, if necessary.
- Rectangular                      Draws a rectangular contour that will define the contour of the prism. Then, using grips, set the upper and lower prism cutoff boundary, if necessary.









Polygonal

Draws a polygonal contour that will define the contour of the prism. Then, using grips, set the upper and lower prism cutoff boundary, if necessary.

eXit

Finishes the process of creating a new prism.

## Bounding Prism by Object

-  Ribbon: **View – Visibility Manager >**  **Bounding prism by Object**
-  Menu: **View >**  **Bounding Prism by Object**
-  Toolbar: **View Toolbar –**  **Bounding prism by Object**
-  Command line: **MCLIPBYSELECTION**

Creates a bounding prism based on the selection made prior to running the command. The prism will be created with the dimensions of a rectangular box describing the sample. If there is no preselection, you will be prompted to select objects. The result of the command operation is similar to the result of work of the **Bounding prism** command with the **Select** option.

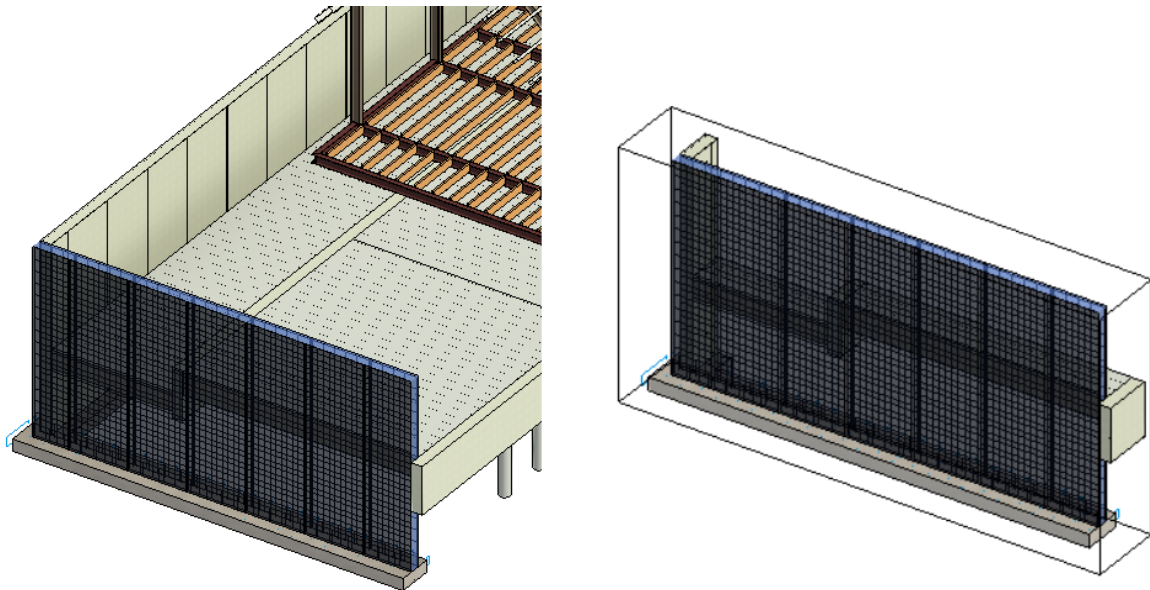

## Viewports of Model Space

Model space can be separated into several rectangular *non-overlapping* areas called *viewports*.

*Non-overlapping areas* fill in model space and cannot be placed over each other. When starting a project, usually one viewport, filling in all the model space is used. This viewport can be separated into several viewports and different fragments of the drawing, or model views can be displayed on every viewport at the same time. The changes made in one viewport are also shown in the whole drawing (in other viewports). You can switch between viewports at any time, even whilst a command is being performed. To switch to another viewport, click at any point on the screen. The cursor is displayed in the current viewport – the common arrowhead is displayed in all the other viewports.

For every viewport you can specify the display scale, pan the viewport image independently of the other viewports, specify UCS and display the modes of grid and snap usage. You can save

the setting parameters of any viewports to use them again and restore an image of any viewport.

Only one **non-overlapping viewport** can be printed.

Configuration of **non-overlapping viewports** can be different:

## 1 Viewport



Ribbon: **View – Model Viewports – Viewport Configuration** >  **Single**



Menu: **View – ViewPort** >  **1 Viewport**



Toolbar: **ViewPorts** > 



Command line: **VIEWPORT\_SINGLE**

In Model Space: restores the configuration to one viewport (the view is taken from the last active window).

In Paper Space: creates one viewport.

## 2 Viewports Vertical



Ribbon: **View – Model Viewports – Viewport Configuration** >  **Two: Vertical**



Menu: **View – ViewPort** >  **2 Viewports Vertical**



Toolbar: **ViewPorts** > 



Command line: **SPLITVIEWPORT\_VERTICAL**

Creates a configuration of two vertical viewports.

## 2 Viewports Horizontal



Ribbon: **View – Model Viewports – Viewport Configuration** >  **Two: Horizontal**



Menu: **View – ViewPort** >  **2 Viewports Horizontal**



Toolbar: **ViewPorts** > 



Command line: **SPLITVIEWPORT\_HORIZONTAL**

Creates a configuration of two horizontal viewports.

## 3 Viewports



Command line: **SPLITVIEWPORT\_3**

Creates a configuration of three viewports.

After starting the command, there is a prompt in the command line:

Enter an option [Horizontal/Vertical/Left/Right/Top/Bottom]**<Right>**

**Command options:**

- Horizontal      Creates a configuration of three horizontally placed viewports.
- Vertical        Creates a configuration of three vertically placed viewports.
- Left             Creates a configuration of three viewports, one of which is placed to the left and the others – to the right.
- Right            Creates a configuration of three viewports, one of which is placed to the right and the others – to the left.
- Top              Creates a configuration of three viewports, one of which is placed at the top and the others – at the bottom.
- Bottom         Creates a configuration of three viewports, one of which is placed at the bottom and the others – at the top.

### 3 Viewports Horizontal

-  Ribbon: **View – Model Viewports – Viewport Configuration** >  **Three Viewports Horizontal**
-  Menu: **View – Viewports** >  **3 Viewports Horizontal**
-  Toolbar: **Viewports** – 
-  Command line: **SPLITVIEWPORT\_3\_HORIZONTAL**  
Creates a configuration of three horizontal viewports.

### 3 Viewports Vertical

-  Ribbon: **View – Model Viewports – Viewport Configuration** >  **Three Viewports Vertical**
-  Menu: **View – Viewports** >  **3 Viewports Vertical**
-  Toolbar: **Viewports** – 
-  Command line: **SPLITVIEWPORT\_3\_VERTICAL**  
Creates a configuration of three vertical viewports.

### 3 Viewports Left

-  Ribbon: **View – Model Viewports – Viewport Configuration** >  **Three Viewports Left**
-  Menu: **View – Viewports** >  **3 Viewports Left**
-  Toolbar: **Viewports** – 
-  Command line: **SPLITVIEWPORT\_3\_LEFT**

Creates a configuration of three viewports, one on the left and two on the right.

### 3 Viewports Right

-  Ribbon: **View – Model Viewports – Viewport Configuration** >  **Three Viewports Right**
-  Menu: **View – Viewports** >  **3 Viewports Right**
-  Toolbar: **Viewports** – 
-  Command line: **SPLITVIEWPORT\_3\_RIGHT**

Creates a configuration of three viewports, one of which is located on the right, and two on the left.

### 3 Viewports Top

-  Ribbon: **View – Model Viewports – Viewport Configuration** >  **Three Viewports Top**
-  Menu: **View – Viewports** >  **3 Viewports Top**
-  Toolbar: **Viewports** – 
-  Command line: **SPLITVIEWPORT\_3\_ABOVE**

Creates a configuration of three viewports, one at the top and two at the bottom.

### 3 Viewports Bottom

-  Ribbon: **View – Model Viewport – Viewport Configuration** >  **Three Viewports Bottom**
-  Menu: **View – Viewports** >  **3 Viewports Bottom**
-  Toolbar: **Viewports** – 
-  Command line: **SPLITVIEWPORT\_3\_BELOW**

Creates a configuration of three viewports, one at the bottom and two at the top.

### 4 Viewports

-  Ribbon: **View – Model Viewports – Viewport Configuration** >  **Four: Equal**
-  Menu: **View – ViewPort** >  **4 Viewports**
-  Toolbar: **ViewPorts** > 



Command line: **SPLITVIEWPORT\_4**

Creates a configuration of four similar viewports.

## Named Viewports



Ribbon: **View – Model Viewports –> Named**



Menu: View – **Viewports > Named Viewports**



Toolbar: **ViewPorts – Viewports**



Toolbar: **Layout – Viewports**



Command line: **VIEWPORTS, VPORTS**

The command opens the **Viewports** dialog box.

On the **New Viewports** tab you can create the required configuration of viewports on the standard base and save it for further usage:

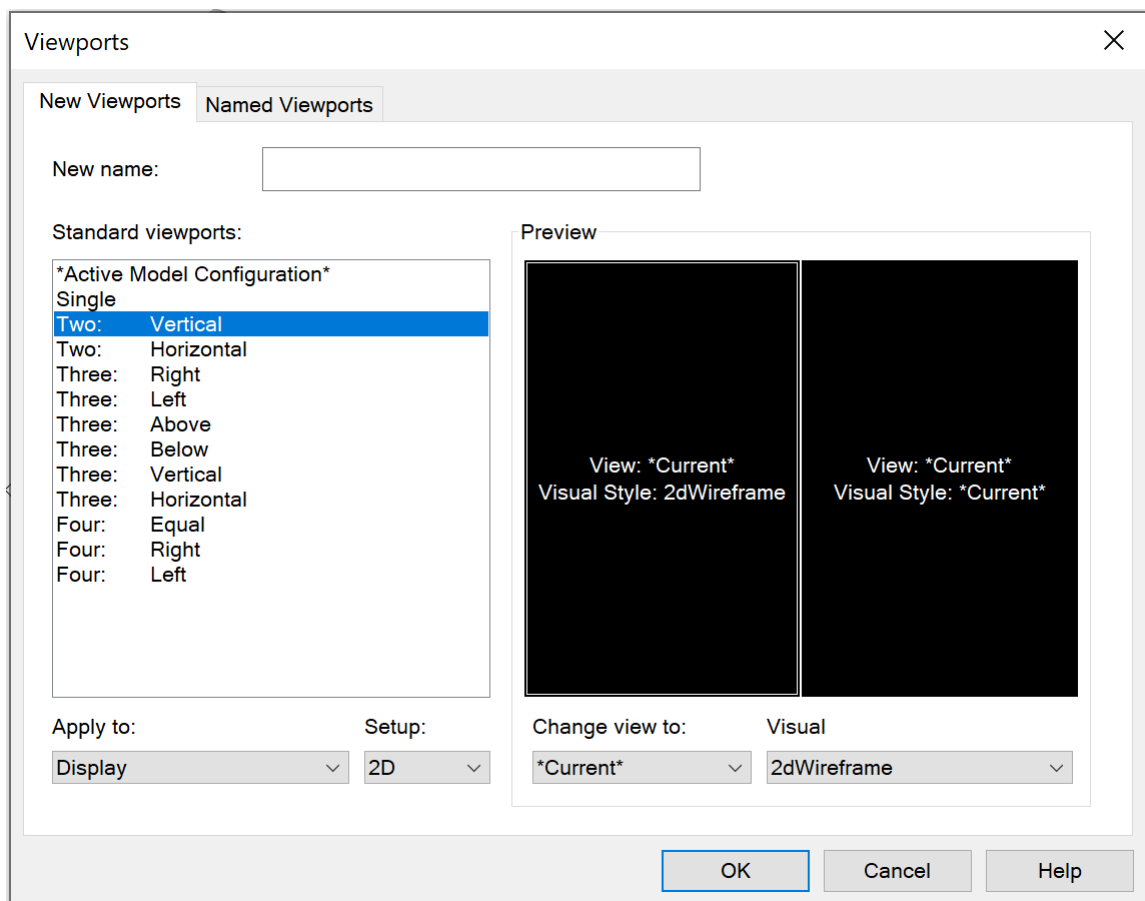

### Parameters:

**New name:** Name of the saved configuration of viewports.

**Standard viewports:** List of standard configurations of viewports.

*Apply to:*

**Display** Applies the selected configuration of viewports to the whole Model Space.

**Current viewport** Applies the selected configuration of viewports to the current viewport.

*Setup:*

**2D** Sets the selected configuration as the current viewport for all viewports.

**3D** Sets the selected configuration of standard model views for all viewports.

*Preview*

Preview of the selected configuration of viewports.  
The current viewport is shown with a double frame.

**Change view to:** Changes the view of the common viewport.  
There are existing named views of the drawing in the drop-down list (there are additional standard model views for 3D mode).

**Visual style:** Changes the visual style of the selected viewport.  
The available styles in the drop-down list are:

- **\*Current\***
- **2D Wireframe**
- **Conceptual**
- **Realistic**
- **Wireframe**
- **Hidden**
- **Shades of Gray**
- **Sketchy**
- **X-ray**
- **Shaded with edges**
- **Shaded**
- **Monochrome**

*To change a view or a visual style for a viewport:*

1. Double click to select the viewport in the **Preview** window (selected object is shown with double frame).
2. Select the required view or visual style from the drop-down list.

If a name was specified during the creation of the configuration of the viewports, the configuration will be saved as a *named configuration*. A *named configuration of viewports* can be used without preset.

The list of created and saved configurations is shown on the **Named Viewports** tab:

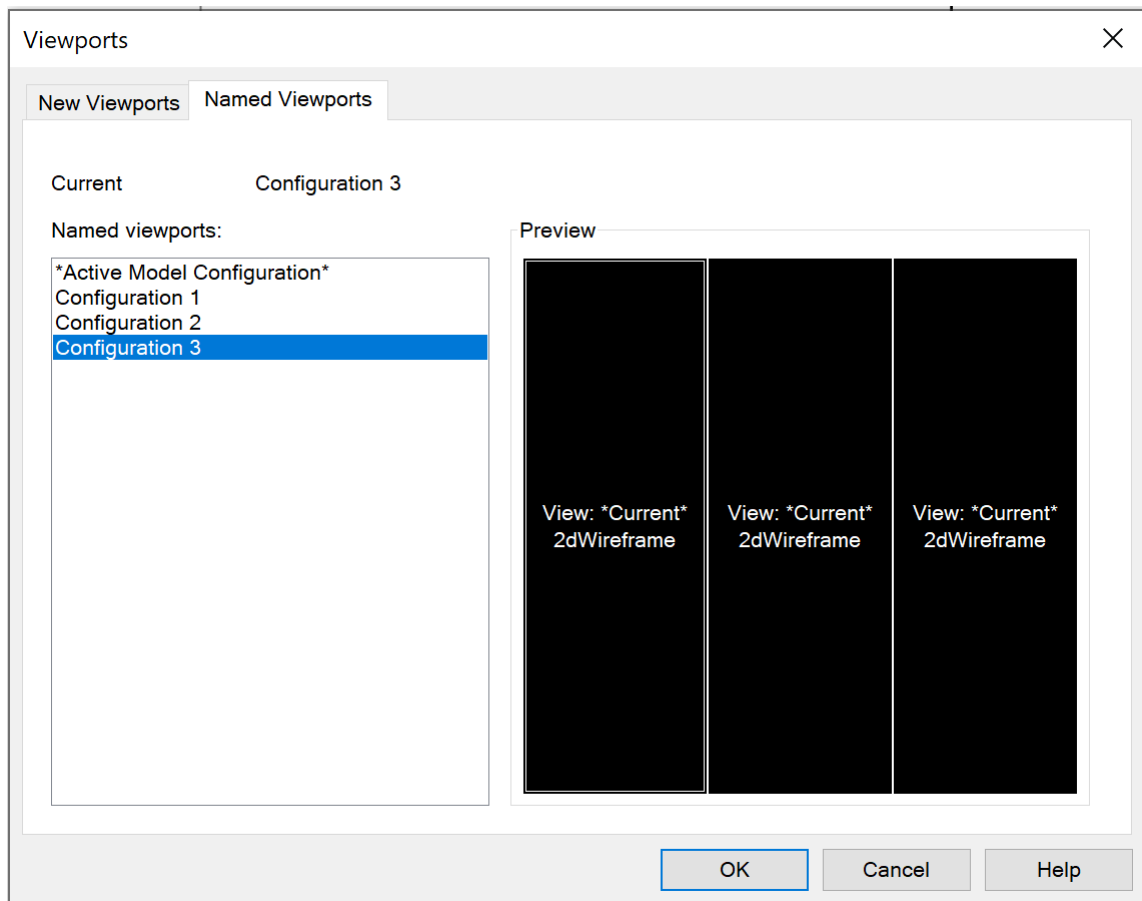

**To create a configurations of viewports:**

1. Select a standard configuration in the **New Viewports** tab.
2. In the **New name** enter a configuration name.
3. Select **OK**.

The name of the created configuration is shown in the **Named viewports** section of the **Named Viewports** tab when the **Viewports** dialog is opened next time.

The **Save Configuration** command from the **View>Viewports** menu allows a name to be specified in the command line for the current configuration of viewports.

**To restore a configuration of viewports:**

1. Select the required configuration in the **Named viewports** list (after selection, a list of viewports will be selected in the **Preview** window).
2. Select **OK**.

Or:

1. Start the **Restore Configuration** command (the **View>Viewports**).
2. In the command line, type the configuration name as an answer to the prompt **Enter viewport configuration name:** (the list of available configurations is shown in the command line's protocol).
3. Press **ENTER** to finish the command.

**To rename a configuration of viewports:**

1. Select the required configuration in the **Named viewports** list (after selection, a list of viewports will be selected in the **Preview** window).
2. Select the **Rename** option from the context menu.
3. Enter a new configuration name.

4. Press **ENTER** or click on any place of the section except the renaming field to finish the command.
5. Select **OK**.

#### **To delete a configuration of viewports:**

1. Select the required configuration in the **Named viewports** list (after selection, a list of viewports will be selected in the **Preview** window).
2. Select the **Delete** option from the context menu.
3. Select **OK**.

Or:

1. Start the **Delete Configuration** command (the **View>Viewports**).
2. In the command line, type the configuration name as an answer to the prompt **Enter viewport configuration name:** (the list of available configurations is shown in the command line's protocol).
3. Press **ENTER** to finish the command.

## **Managing Viewports from the Command Line**



Command line: **-VPORTS, -VIEWPORTS**

The command allows managing viewports both in model space and paper space.

The prompt with available options is displayed in the command line, after the command is launched:

```
Enter viewport option
[Save/Restore/Delete/1/2/3/4/Object/Polygonal/REctangular/
Fit/ON(off)/Lock(unlock)/Clip/LAyer]<1>:
```

#### **Command options:**

- |                |  |
|----------------|--|
| <u>Save</u>    | Saves a current configuration of viewports in model space.<br>When the option is selected, model space is switched to paper space.   |
| <u>Restore</u> | Restores previously saved configuration of viewports (selected configuration is shown on the screen).<br>When a configuration is selected in paper space it is offered to create a configuration of viewports the same as a current configuration of viewports in model space.<br>You can perform the operation with <b>Restore configuration</b> command. |
| <u>Delete</u>  | Deletes a previously saved configuration of viewports in model space.<br>You can perform the operation with the <b>Delete configuration</b> command.   |
| <u>1</u>       | Restores a configuration with one viewport (view is taken from the last viewport) in model space.<br>Creates one viewport in paper space.  |
| <u>2</u>       | Creates a configuration with horizontal or vertical arrangement of viewports. An arrangement is specified with an option from the command line:<br><pre>Enter an option [Horizontal/Vertical]&lt;Vertical&gt;:</pre>   |
| <u>3</u>       | Creates a configuration of three viewports. An arrangement is specified with an option from the command line:<br><pre>Enter an option</pre>  |



[Horizontal/Vertical/Left/Right/Top/Bottom]<Right>:

- 4 Creates a configuration of four viewports.
- Object Transforms previously created closed objects (circles, ellipses, closed polylines and splines) into viewports in paper space (for more information see "Create a viewport by object" section).
- Polygonal Creates a polygonal viewport in paper space.  
Option is available in a current layout, where you want to place a viewport, and also is available in model space (for more information see "Create a polygonal viewport" section).
- REctangular Creates a rectangular viewport in paper space.  
Option is available in a current layout, where you want to place a viewport, and also is available in model space (for more information see "Create a rectangular viewport" section).
- Fit The option allows creating an inscribed viewport in a current layout, where all objects from model space are inscribed.
- ON(off) Switches on/off display of viewport content.
- Lock(unlock) Locks/unlocks a viewport.  
You can lock a viewport to make earlier specified scale unchanged (zooming inside a viewport does not change a scale of viewport).
- Clip Clips borders of viewports (for more information see "Set show boundary for a viewport" section).
- LAyer Resets viewport layer property overrides.

## Visual Styles

nanoCAD allows you to set methods (styles) for displaying three-dimensional objects in the current viewport. You can change the visual style of a viewport in the **Properties** bar in **Miscellaneous** section, or by using the view control widget at the top of the viewport.

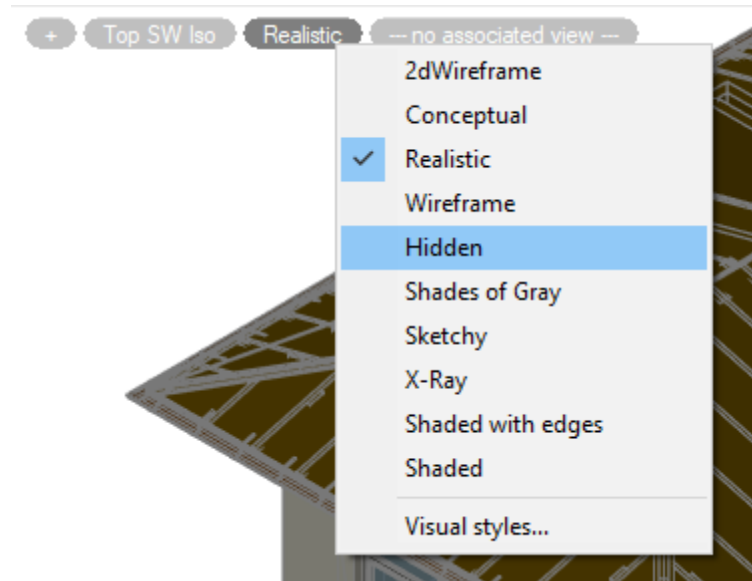

### Predefined visual styles:

**2dWireframe** – the style is intended to work with flat drawings. Only edges are displayed as lines and curves that represent surface boundaries. Fills and hatches are not displayed. The type and weight of lines are taken into account. Raster and OLE objects are visible. See below for more details on the visual style.

**Conceptual** – objects are displayed using smooth shading and Gooch face style. Gooch's face style is characterized by transitions between cold and warm, rather than between dark and light shades of colors. This effect is less realistic, but it better represents the model details.

**Realistic** – objects are displayed using smooth shading and showing materials.

**Wireframe** – only edges are displayed in form of lines and curves that represent the boundaries of surfaces. Line type and weight are not taken into account, raster objects are not displayed. When using materials, the color of lines is determined by the color of material. Draw order and fill options from 2D solids are not displayed.

This visual style does not result in repeated creation of the view when its direction changes, as is the case with the **2dWireframe** visual style. In large 3D models, the time savings will be significant.



**Hidden** – objects are represented as a wireframe. Unlike the **Wireframe** style, edges hidden by opaque surfaces are not displayed.

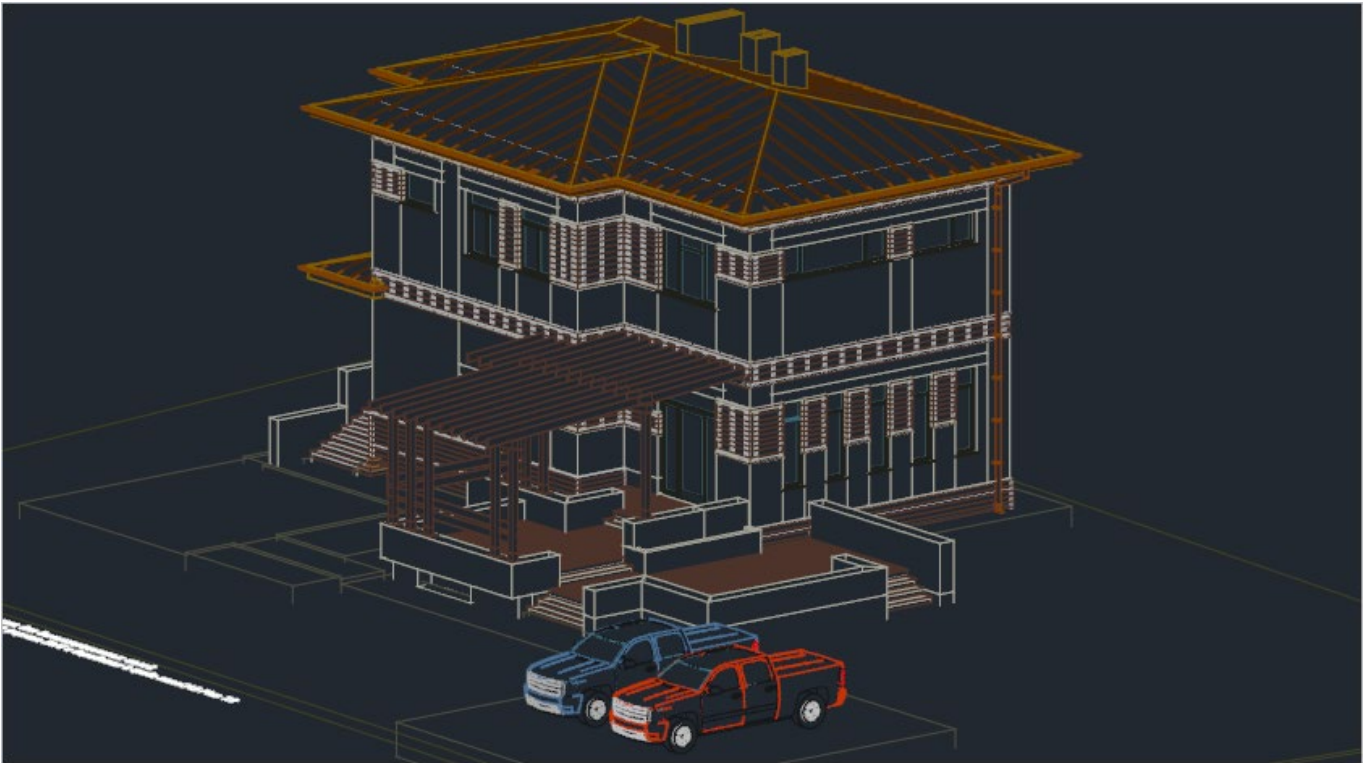

**Shades of Gray** – objects are displayed using shades of a single color (gray) with smooth transitions.

**Sketchy** – objects are displayed with a freehand drawing effect, taking into account the **Line Extend** and **Jitter** edge modifiers.

**X-Ray** – objects are displayed partially transparent.

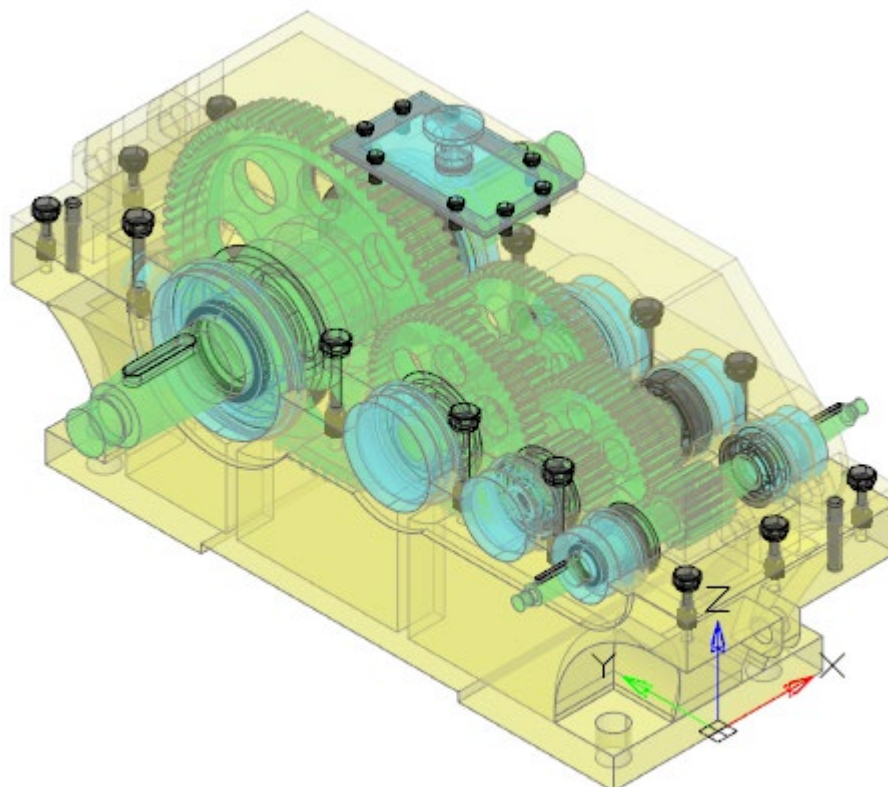

**Shaded with edges** – objects are displayed using smooth shading with visible edges.

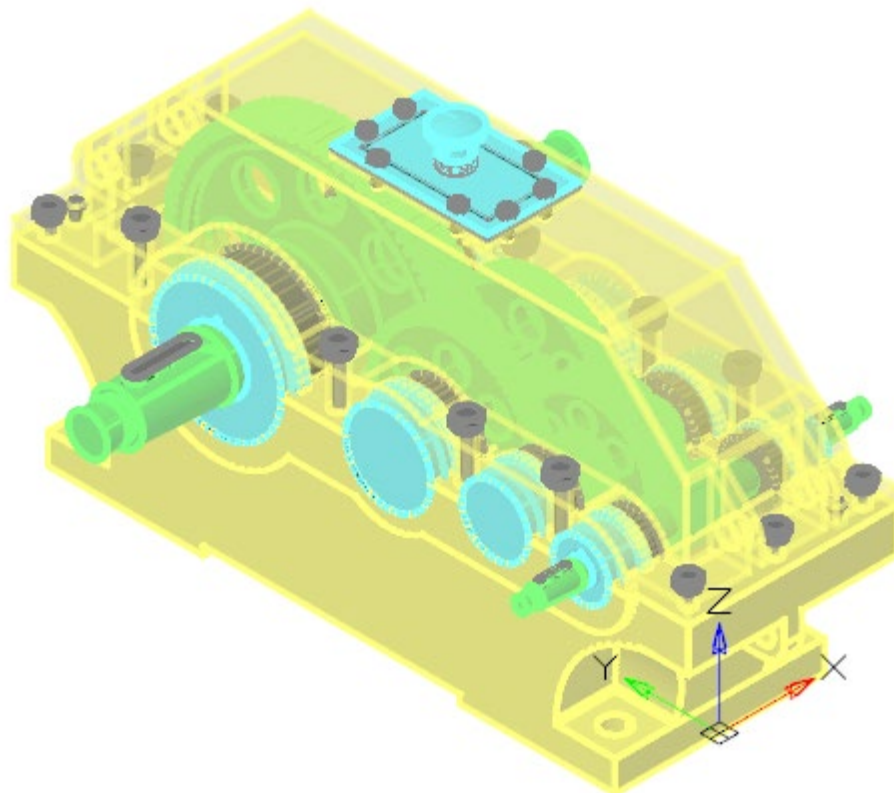

**Shaded** – objects are displayed using smooth shading with no overtly defined edges.

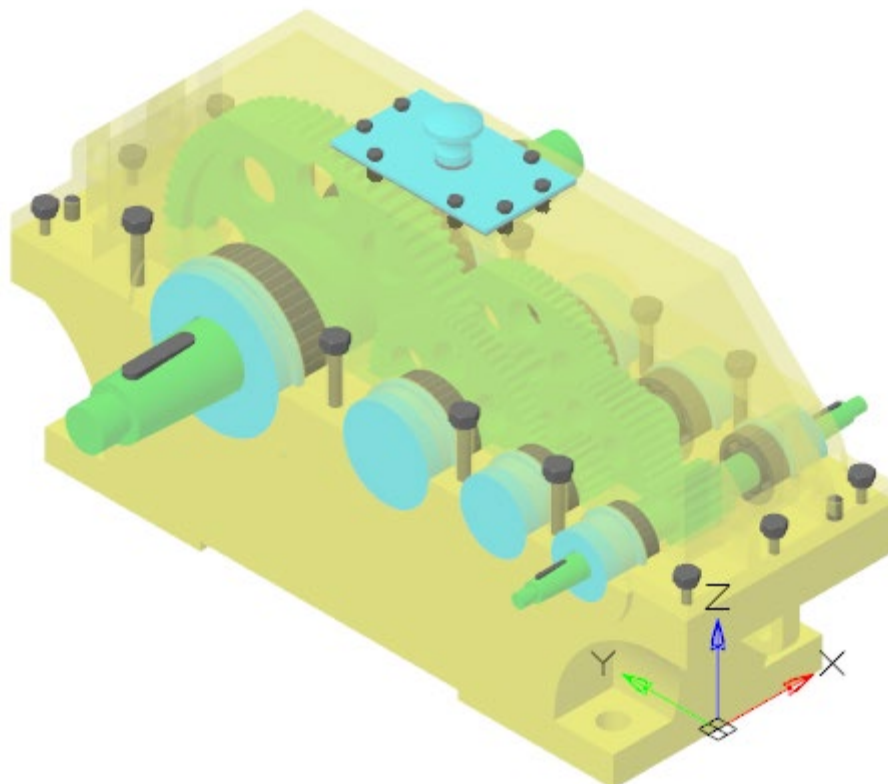

## Feature of 2D Wireframe Visual Style

This style is intended for working with flat drawings. Only edges are displayed as lines and curves that represent surface boundaries. Fills and hatches are not displayed. The type and weight of lines are taken into account. Raster and OLE objects are visible.

The **2D Wireframe** style settings are not editable in the Visual Styles Dialog Box and cannot be used to create a user defined style.

### Work with incorrect z-coordinates

When **2D Wireframe** style is used in conjunction with a top view, the z-coordinate values are ignored when displaying and redrawing the drawing. This allows you to quickly display and work with incorrect documents, which are flat drawings, the objects of which have a spread of coordinates in height, often very significant. As a rule, such a spread appears after incorrect conversion of 2D drawings to 3D DWG format by third-party CAD systems. If other visual styles are used, such drawings may take a significant amount of time to display and redraw.



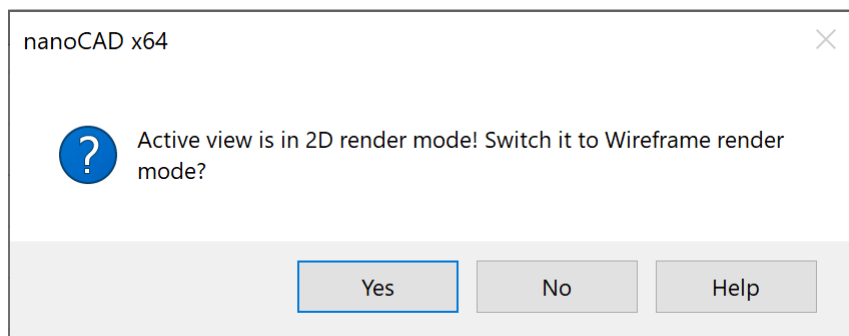

**NOTE:** To correct (zero) the z-coordinates of objects in such drawings, use the **AUDITGEOMETRY** geometry check command.

### Work with point clouds

**2D Wireframe** style is not designed to work with point clouds. When importing point clouds into a viewport with **2D Wireframe** style set, you will be prompted to automatically switch to **Wireframe** visual style, which you should accept.



## Visual Styles Manager

-  Ribbon: **View – Visualization – Visual Styles >**  **Visual Styles**
-  Menu: **View – Visual Styles >**  **Visual Styles**
-  Toolbar: **Main –** 
-  Command line: **VISUALSTYLES**

To create, edit, apply, and delete visual styles, use the **Visual Styles** functional panel.

The top field displays a list of all standard visual styles and the styles of the current document. The options for the visual style selected from the list are displayed below.

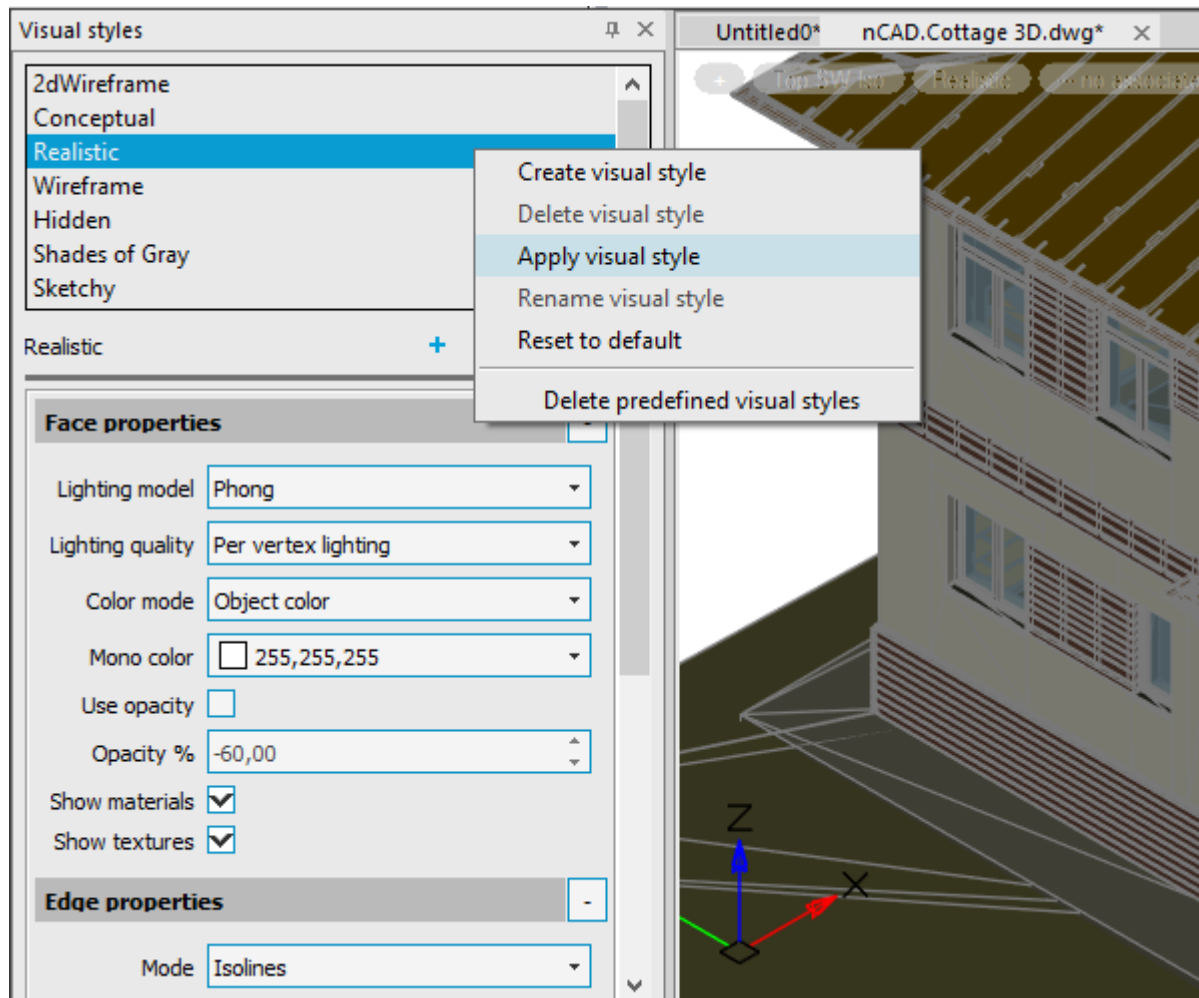

### Actions with a visual style

Actions with the selected style are available from the context menu or using the buttons.

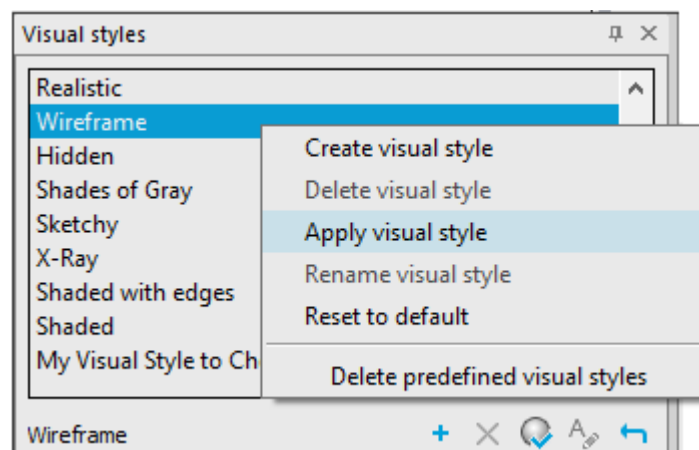

- Create visual style**

Creates a new visual style based on the settings of the selected style. Allows you to specify a name and explanation for the new style.

It is recommended to create new visual styles rather than changing the settings of the predefined ones.
- Delete visual style**

Removes the selected visual style. Inbuilt styles and the current viewport style cannot be deleted.



### Apply visual style

Applies the selected visual style to the current viewport. When you apply a visual style or change its settings, the corresponding viewport is automatically updated to reflect those changes. Any changes to the current visual style are saved in the drawing.



### Rename visual style

Opens the dialog box for renaming the visual style or editing the description. Inbuilt styles cannot be renamed.



### Reset to default

Resets the style parameter values to the default ones.

### Delete predefined visual styles

Deletes standard visual styles.

## Visual Styles Properties

### Face properties

#### Lighting model

Style of shading for faces, solid fills, and gradient hatches (VSFACESTYLE system variable):

- **Invisible.** Faces seem to be hidden, there is no shading of faces and surfaces. Only the edges of faces are displayed. Used in the **Wireframe** visual style.

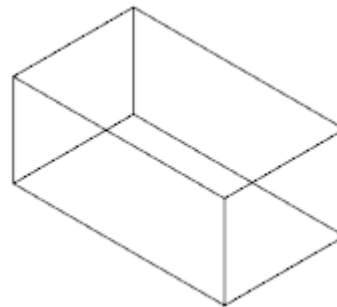

- **Constant.** Uniform shading without transitions. Hidden line suppression makes invisible lines, edges, and other objects that are actually obscured by objects in the foreground. Used in the **Hidden** and **Sketchy** visual styles.

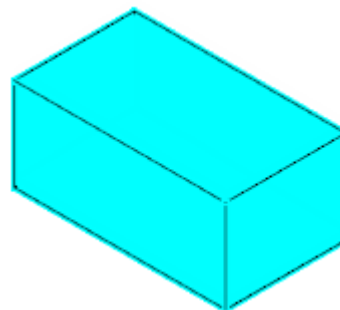

- **Realistic.** Allows you to achieve a realistic shading effect.

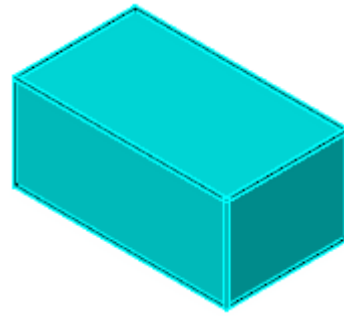

- **Gooch.** This shading method enhances detail by softening the contrast between highlights and shadows. Warm colors are used in lighted areas, cool colors are used in shaded areas.

### Lighting quality

Determines the quality of lighting of object faces. Actually sets the color interpolation method for faces of 3D solids and surfaces in the current viewport (VSLIGHTINGQUALITY system variable).

**No lighting** – faces are not lighted. Depending on the value of the Color parameter, objects are colored in one color or another entirely.



**Per face lighting** – for each face, a specific color is calculated without transitions. Curved surfaces are displayed as a facet approximation.



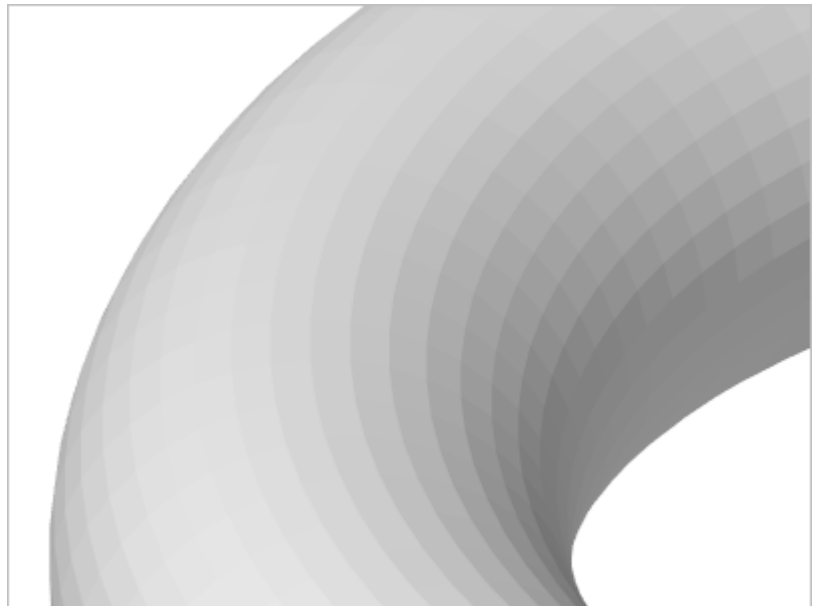

**Per vertex lighting** – colors are calculated for the gradient transition between the vertices of the faces. The style provides a smooth display without the use of hardware acceleration.

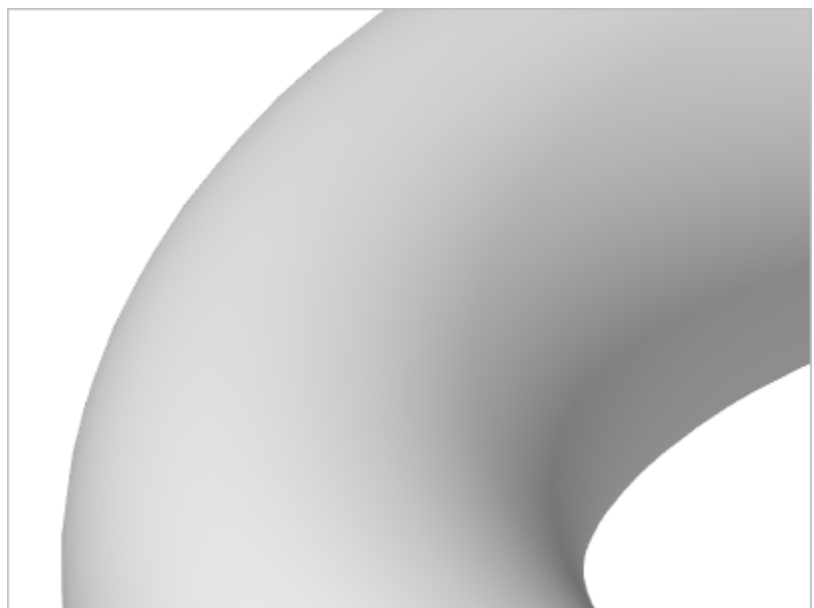

**Per pixel lighting** – the highest smoothing quality.

### Color mode

Specifies the display of colors on faces. (VSFACECOLORMODE system variable):

- **No color mode.** Does not apply to the face color modifier.
- **Object color.** Faces are displayed in different shades of the object's color.

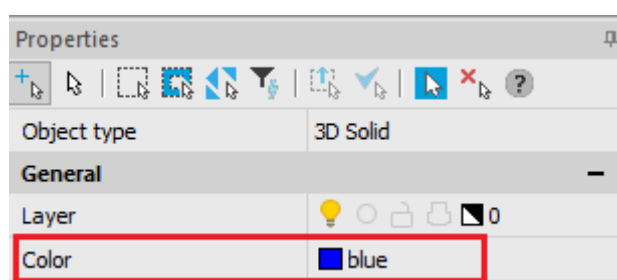

- **Background color.** Faces are displayed in different shades of the background color of the current space.
- **Mono.** Faces are displayed in different shades of the color specified by the **Mono color** option.
- **Tint.** Edges are shaded by changing the tint and saturation values based on the color specified by the **Mono color** option.
- **Desaturate.** Edges are displayed in different shades of the object's color softened by reducing its saturation by 30%.

**Mono color** Allows you to select a monochrome color or a color tint depending on the color mode of the face (VSMONOCOLOR system variable). The setting has an effect if the face color mode is set to **Mono** or **Tint**.

**Use opacity** All objects are displayed semi-transparent. The degree of transparency is controlled by the **Opacity %** option.

**Opacity %** The degree of opacity of objects: 0% - completely transparent, 100% - completely opaque. Only taken into account when the **Use opacity** box is checked.

**Show materials** Enables the display of assigned materials.

**Show textures** Enables the display of assigned textures.

### Edge properties

**Mode** Method to display edges of objects (VSEDGES system variable):

- **No edges.** Do not display edges.
- **Isolines.** Display by isolines.
- **Facet edges.** Display by face edges.

**Color** The color of edges. (VSEDGECOLOR system variable)

### Obscured edge properties

**Show** Display object edges hidden by graphics (VSOCCLUDEDGEDGES system variable).

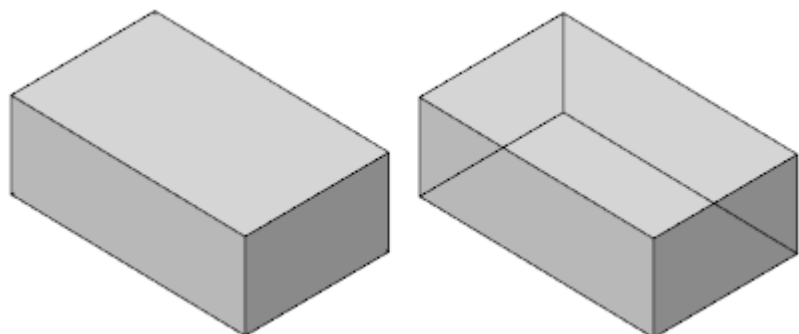

**Color** The color of overlapped edges (VSOCCLUDEDCOLOR system variable)

variable).

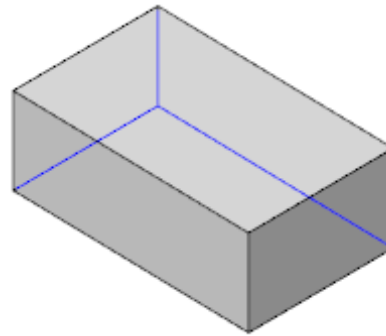

**Pattern**

The line type for displaying overlapped edges (VSOCCLUDEDTYPE system variable).

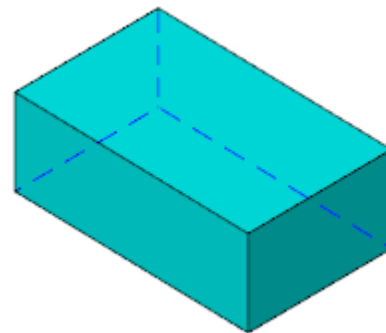

*Intersection edge properties*

**Show**

Display intersection edges of 3D objects (VSINTERSECTIONEDGES system variable). Can significantly slow down the work with large drawings.

**Color**

Color of intersection edges (VSINTERSECTIONCOLOR system variable).

**Pattern**

Line type of intersection edges (VSINTERSECTIONLTYPE system variable).

*Silhouette edge properties*

**Show**

Display silhouette edges of 3D objects. (VSSILHEDGES system variable).

**Width**

The width at which silhouette edges are displayed. (VSSILHWIDTH system variable).

## Isometric Drafting



Status bar:  button



Toolbar: **Isometry** - 





### ***Impact of the mode on drawing settings and precision tools***

Enabling (disabling) the isometric drawing mode, as well as setting this or that isoplane changes a number of related drawing parameters and settings, for example, drawing precision tools. The following settings and modes change automatically:

- orthogonal directions;
- snap orientation;
- grid orientation;
- polar tracking angles;
- orientation of isometric circles, arcs and rectangles when they are created.

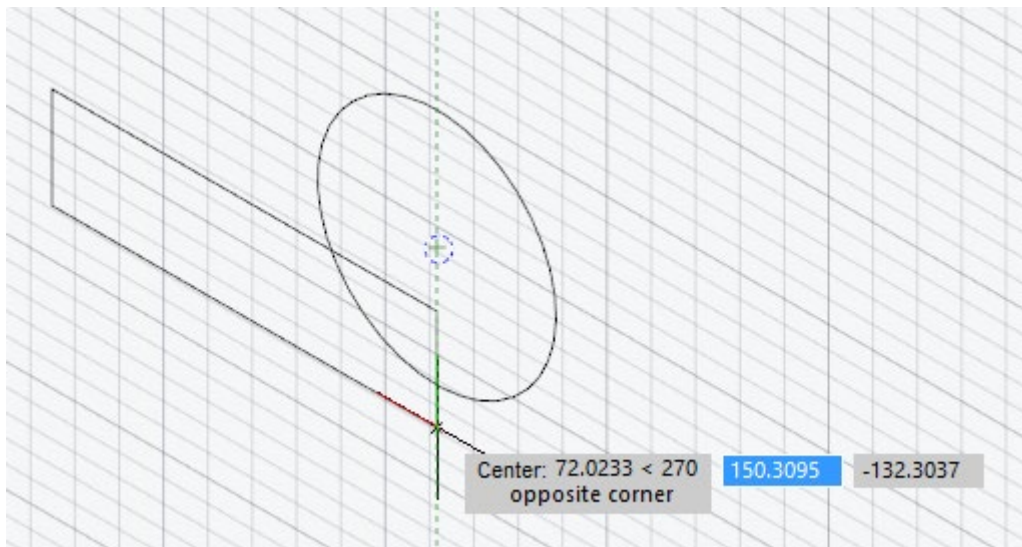



### ***Frequently used tools in isometric drawing***

In the process of creating isometric drawings, the following construction and precision tools are most commonly used:

- Polar tracking and direction-distance method;
- Object snaps and grid snaps;
- Object tracking;
- Moving and copying;
- Cropping and lengthening.

### ***Enabling isometric drafting mode***

The isometric drafting mode is enabled in several ways:

- By -ISODRAFT command, by  button on the **Isometry** toolbar or by  button in the status bar;

- By isometric snap in the **Snap and Grid** tab in the **Drafting settings** dialog box:

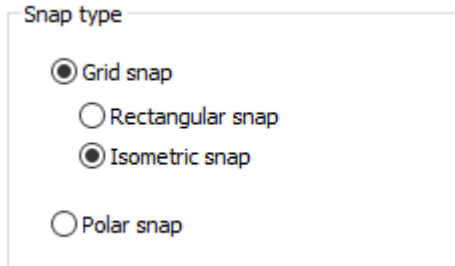

- Setting 1 as a value for SNAPSTYL system variable;
- Enabling one of isometric planes:
  - by selecting one of ISOPLANE options of the ISODRAFT command;
  - by selecting one of planes on the **Isometry** toolbar;
  - By the command ISODRAFT1 (isoplane left), ISODRAFT2 (isoplane top), ISODRAFT3 (isoplane right);
  - By changing the value of SNAPISOPAIR system variable: 0 – isoplane left, 1 – isoplane top, 2 – isoplane right.

**NOTE:** to switch quickly between isoplanes, use F5 key.

### Creating geometric entities

The following commands are used to create circles, arcs, rectangles in the current isometric plane.

#### Creating isocircle

To create a circle in the current plane, use  ISOCIRCLE command that starts the ELLIPSE command with the **Isocircle** option.

If the isodraft mode is disabled at the moment the ISOCIRCLE command is started, then the isometric mode will be enabled first, after which it will be possible to create a circle in the selected isoplane.

The **Isocircle** option of the ELLIPSE command is available only when isometric mode is enabled. When you select the **Isocircle** option, a circle will be drawn in the current isoplane.

The process of drawing a circle in the isodraft mode does not differ from the same action with the disabled isodraft mode: you should specify the center of the circle and select the radius/diameter of the future circle.

#### Creating isorectangle

To create a rectangle in the current plane, use  ISORECTANGLE command that starts the RECTANGLE command with the **Isorectangle** option.

If the isodraft mode is disabled at the moment the ISORECTANGLE command is started, then the isometric mode will be enabled first, after which it will be possible to create a rectangle in the selected isoplane.

The **Isorectangle** option of the RECTANGLE command is available only when isometric mode is enabled. When you select the **Isorectangle** option, a rectangle will be drawn in the current isoplane.

The process of drawing a rectangle in the isodraft mode does not differ from the same action with isodraft mode disabled: you should specify the point of the first corner of the rectangle and select the point of the diametrically opposite corner/dimensions of the rectangle.

### Creating isoarc

To create an elliptical arc in the current isometric plane, use  ISOARC command that starts creating an elliptical arc by the ELLIPSE with the **Arc** > **Isoarc** option.

If the isodraft mode is disabled at the moment the ISOARC command is started, then it will be enabled first, after which it will be possible to create an arc in the selected isoplane.

The **Isoarc** option of the ELLIPSE command is available only when isometric mode is enabled. When you select the **Isoarc** option, an arc will be drawn in the current isoplane.

The process of drawing an arc in the isodraft mode does not differ from the same action with isodraft mode disabled.

### SNAPSTYL system variable

The system variable allows you to change the drawing mode. The variable values are integers:

- 0 – standard drawing mode;
- 1 – isometric drawing mode.

### SNAPISOPAIR system variable

The system variable allows you to change the current isometric plane in the current viewport. The variable values are integers:

- 0 – left plane of isometry,
- 1 – top plane of isometry,
- 2 – right plane of isometry.

## Drawing Regeneration

Sometimes, when you are working with a document after the command is finished, some visual elements stay on the drawing; for example, markers of characteristic points. To delete such visual elements, use forced *regeneration* (specified manually) or *redrawing* of a drawing.

Two commands in nanoCAD are used for it: **Regen** and **Redraw** (**View** menu).

*Redrawing* a drawing is faster than *regeneration* because all the drawing objects' coordinates are recalculated (converting values with floating points from the drawing database to integer display coordinates) during regeneration.

### Regeneration



Menu: **View** –  **Regen**



Status bar: 



Command line: **RE, REA, REGEN, REGENALL**

The **Regen** command is used for a forced update of a current drawing.

Command performs following actions:

- Recomputes the locations and visibility for all objects
- Recalculates tables
- Updates automatically calculated attribute values.

## *Redrawing*



Menu: **View – Redraw**



Command line: **Redraw**

The **Redraw** command is used for a forced update of a display.



## OBJECTS' PROPERTIES

In nanoCAD, graphic drawing objects have properties, such as *color, type and weight (width) of lines, transparency and plot style*, which can be changed.

When placing the cursor over any object on the screen, a tooltip with the object's name, name or number of its color and layer where the object is placed, appears:

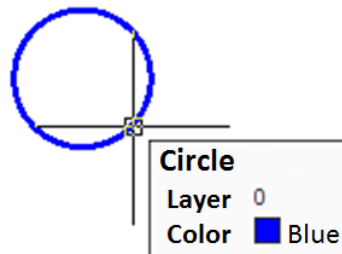



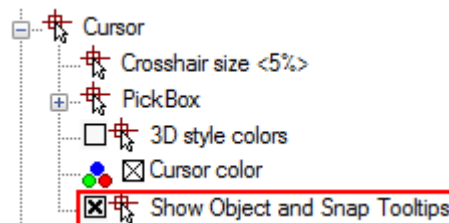









The display of a tooltip can be switched off in the **Cursor** section of the **Options** dialog box (**Tools – Options**):







Set different properties for objects for the document's clarity. When creating new objects, their properties are inherited from the description of the layer where they were created.

## “Properties” Bar

-  Ribbon: **Home – Properties >**  **Properties**
-  Menu: **Tools –**  **Properties**
-  Menu: **Modify –**  **Properties**
-  Menu: **View – Toolbars > Functional >**  **Properties**
-  Toolbar: **Main –** 
-  Hotkeys: **CTRL+I**
-  Command line: **INSP, INSPECTOR, PROPERTIES**

The **Properties** bar is used to display information about selected objects, to change objects' properties, to specify a selection mode and call up selection commands.

The list of properties is separated into groups. Manage the visibility of properties of any group by using the  and  buttons in the group name. The  button shows the properties for the hidden group. When this button is selected the properties list of the group is shown and the button switches to the  button.

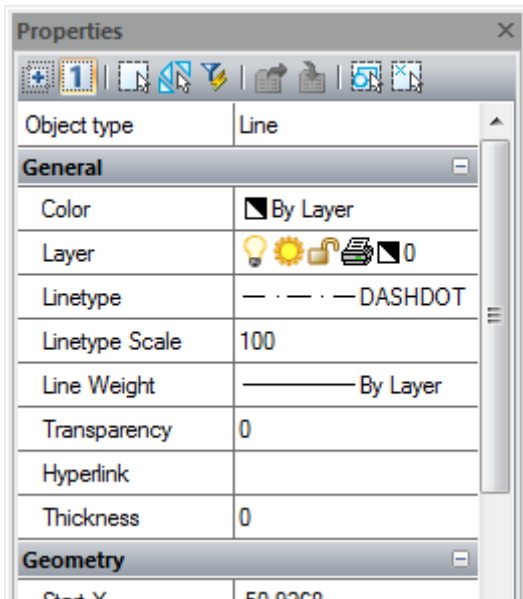

The different properties of objects are displayed in the left column in the **Properties** bar; their values are shown in the right column.

Information in the **Properties** bar depends on the current command and different parameters of the selected objects are shown.

If no object is selected, *No selection* is shown in the **Object type** field:



Current setting parameters for the properties of created objects of the document are shown in the **General** group. For example, the **Line Weight** has a «1.00» value, so new lines, arcs and circles will be created with this weight.

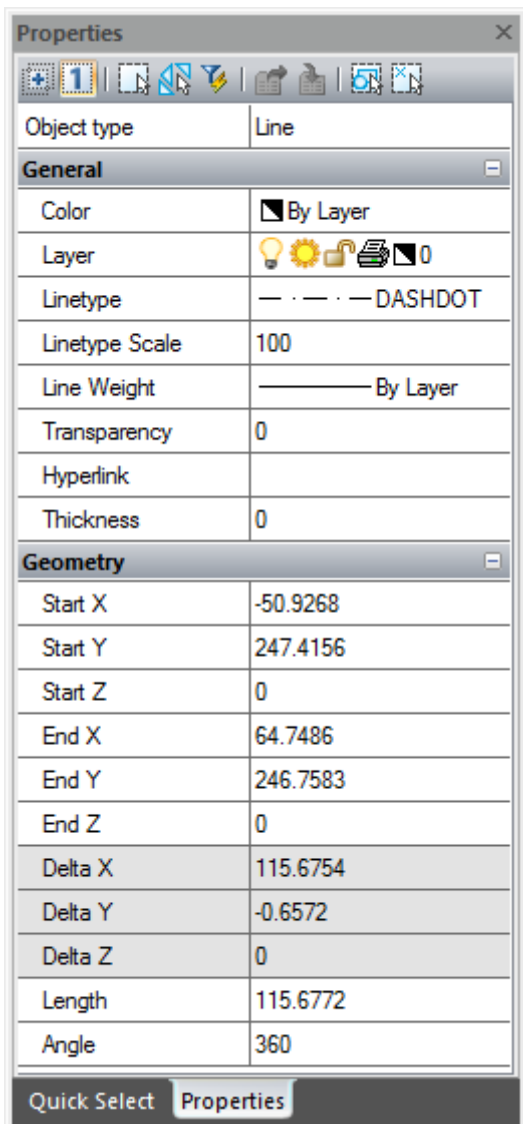

If several objects of one type are selected, their type and number (in brackets) are displayed in the right column:

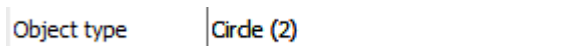

If several objects of different types are selected, All (2) is displayed in the **Objects type** field:

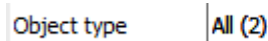

The **General** group contains information about an object's properties: color, layer, line type etc.

The **Geometry** group displays information about the geometric parameters of an object and its position in the document.

Properties that can be changed are shown in black in the left column.

You can specify new values for these properties in the corresponding fields. Values outside of the limits are not used automatically.

The grey color is used to display information about properties which cannot be changed and for properties depending on other properties.

If several objects are selected, only properties common to all the objects are displayed.

If any property does not have a value (the field in the column is empty); two or more objects having the property among selected objects, but the values of the property are different, for example center coordinates for two non-concentric circles:

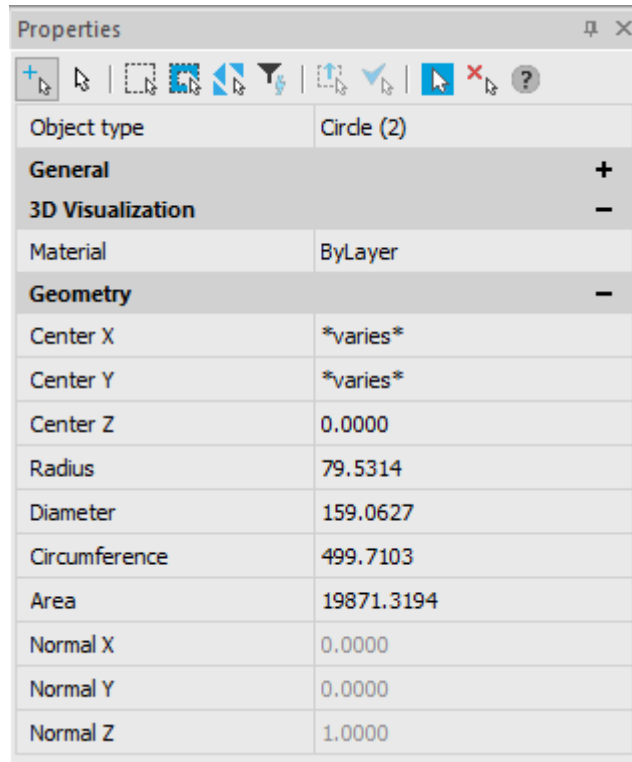







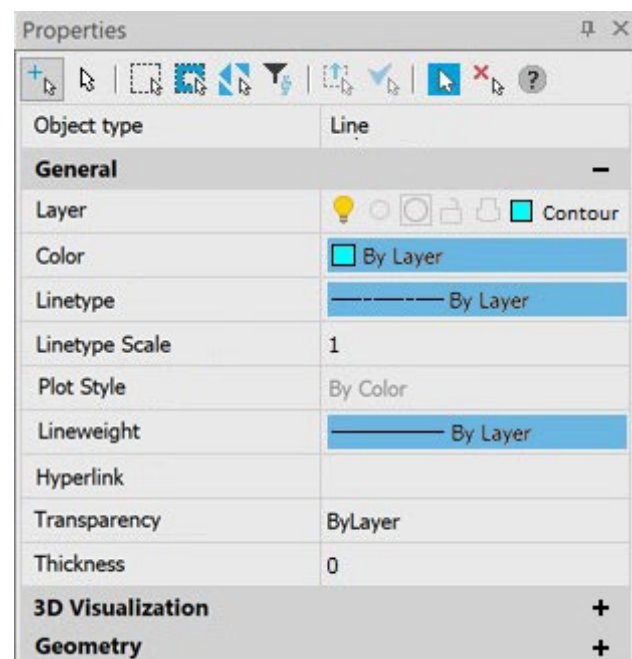

Properties	
Object type	Circle (2)
<b>General</b> +	
<b>3D Visualization</b> -	
Material	ByLayer
<b>Geometry</b> -	
Center X	*varies*
Center Y	*varies*
Center Z	0.0000
Radius	79.5314
Diameter	159.0627
Circumference	499.7103
Area	19871.3194
Normal X	0.0000
Normal Y	0.0000
Normal Z	1.0000

The value, entered in such a field, is one for this property for all objects selected, if it can be applied.

In unlocked value input fields (for properties of REAL type) it is possible to calculate mathematical expressions (for more information, see the Math Processor section).

Layers and objects that have property overrides in viewports are highlighted in blue:



Properties	
Object type	Line
<b>General</b> -	
Layer	     Contour
Color	 By Layer
Linetype	 By Layer
Linetype Scale	1
Plot Style	By Color
Lineweight	 By Layer
Hyperlink	
Transparency	ByLayer
Thickness	0
<b>3D Visualization</b> +	
<b>Geometry</b> +	

Some properties of objects, such as, color, line type, and line weight can be selected from the drop-down list:

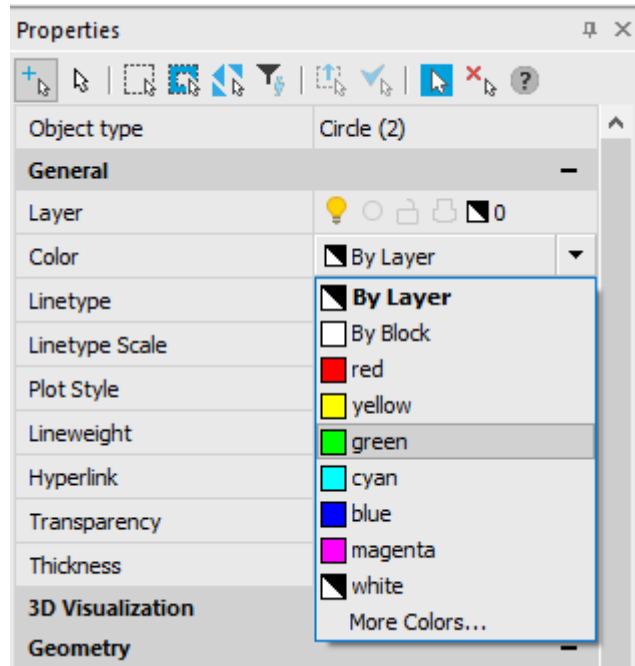

**To change the properties of objects in the Properties bar:**

1. Select one or several objects.
2. Click in the left column of the property that you want to change.
3. Select the required value in the drop-down list to the right of the column or type a new value.
4. To apply a typed property value to the objects, press **ENTER**. Values, selected from a list, are applied to the selected objects immediately without pressing the **ENTER** button.
5. To deselect objects, click in the drawing area or press **ESC**.

There are mode and selection command buttons in the top part of the **Properties** bar:



Description of modes and selection commands, ways of selection for object see in the "[Selection of objects using the Properties bar](#)" section.

## Change Object Properties Command



Command line: **CHPROP**

Changing objects properties using the command line.

**Command options:**

**?** Opening additional options to select objects.

**Command prompts:**

Select objects or [**?**]:

Select objects for editing, press **ENTER**.  
If several objects selected have different values for the property to be changed, the **<\*varies\*>** value is displayed as the current one.

Enter property to change

Specify the property to be changed.

[Color/LAyer/LType/LtScale/LWeight/Thickness/PLOTstyle]:

Color

Enter new color

[Truecolor/COLORbook]

Changing color of selected objects.

Truecolor – selecting color from the color palette.

COLORbook- selecting color from the downloaded album.

LAYER

Enter new layer name <0>:

Changing layer of selected objects.

LType

Enter new linetype name <ByLayer>:

Changing linetype of selected objects.

LtScale

Specify new linetype scale <1.00>:

Changing linetype scale.

LWeight

Enter new linewidth <ByLayer>:

Changing linewidth of selected objects. Linewidth should have a value from the standard range.

Thickness

Specify new thickness <0.00>:

Changing thickness of 2D object by Z axis. It is not possible to change thickness of 3d polyline, dimension or layout viewport.

PLOTstyle

Changing properties of named plot styles. Available only if named plot styles are used.

## Creation of Custom Properties Fields

The fields in the **Properties** panel display information about selected objects which can be dragged onto an existing or created toolbar, creating a *custom properties field*:

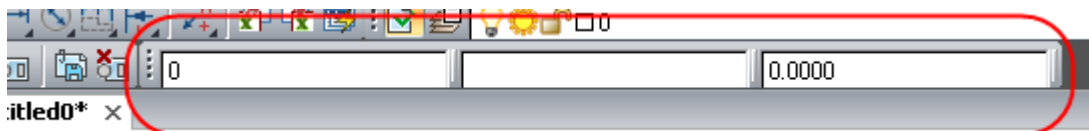

After dragging, only the right column with the values from the **Properties** panel is shown in the toolbar. Name of the property (left column is not displayed).



The value of a property is shown in the **custom properties field** after selection of the object, which property is shown in the field. The field remains empty if an object is not selected or if the selected object does not have properties contained in the field. If several objects are selected, the field is empty unless similar objects are selected, for example circles of one diameter.

One user properties field can contain several fields from the **Properties** panel.

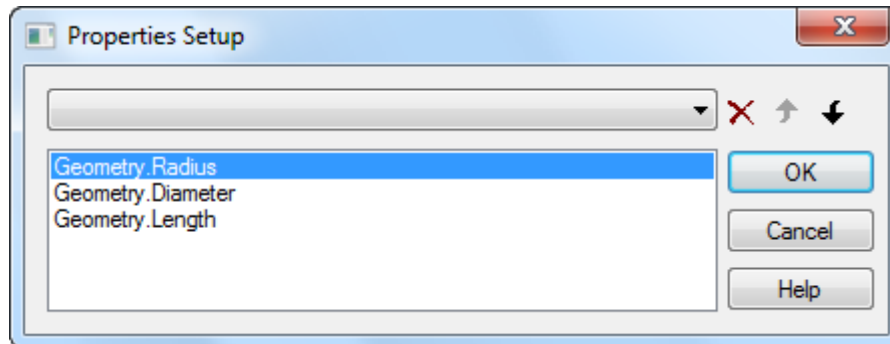
If the user window contains several properties of one properties group or several properties of one object type, only one property (the top property in the **Properties Setup**) is shown when the object is selected:



In this case, when a circle is selected the radius value will be shown; if a line is selected, its length value will be shown; if a single line text is selected, its height will be shown.

The  and  buttons are used to move the selected property in the list.

To display the **Geometry.Diameter** property when a circle is selected, use the  to move this property above the **Geometry.Radius** property:

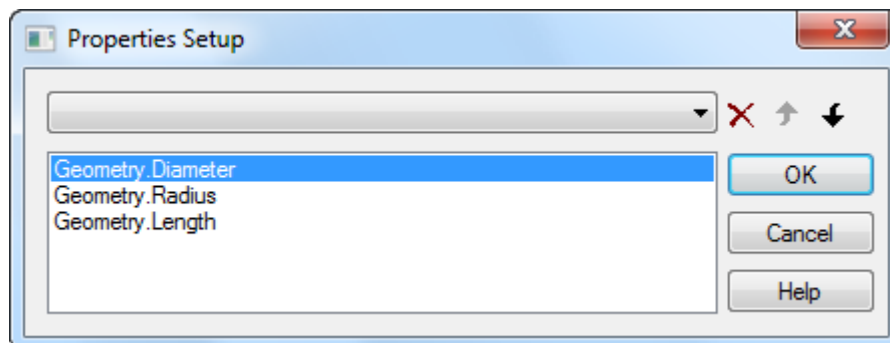

The  button deletes the selected property from the list.

To display two or more properties from one group or one object type, create several fields on the toolbar.

As an example, we will show how to create a toolbar with 3 custom properties fields, the first displays the circle diameter and text height, the second – circumference and text rotation and the third – circle area and text oblique.

**To create custom properties' fields:**

1. Create a new toolbar (for more information how to create a new toolbar see in the **Toolbars tab** section (**Tuning nanoCAD – Tuning the interface**)):



2. Select a circle.
3. Place the cursor over the **Diameter** field in the **Properties** panel.
4. Drag the **Diameter** field, using the left mouse button and **ALT** button, onto the created toolbar:



5. Drag the **Circumference** field to the right of the first field on the toolbar in the same way:

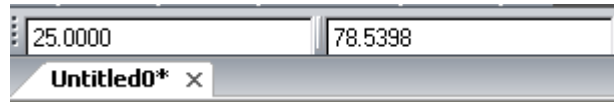

6. Drag the **Area** field to the right of the second field on the toolbar:

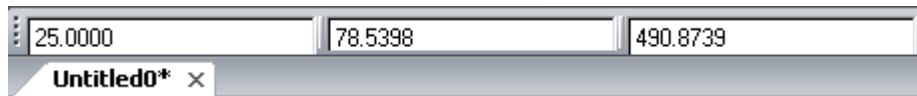

7. Press **ESC** to deselect the circle.

8. From the context menu of the first field select **Setup**:

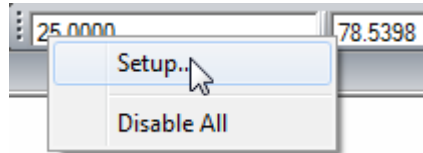

9. In the drop-down list of the dialog box that appears, select the **Text.Text height** property:

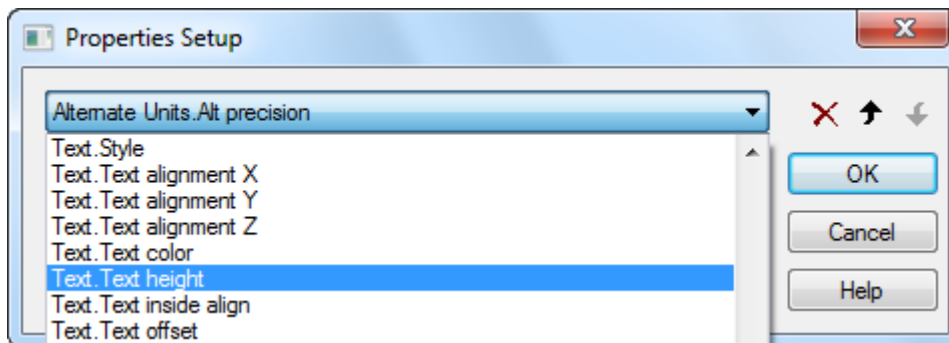

10. Select **OK** to close the dialog.

11. From the context menu of the second field select **Text.Rotation**.

12. Select **OK** to close the dialog.

13. For the third field select the **Text.Obliquing**.

14. Select **OK** to close the dialog.

15. After selecting any circle on the drawing, the values for its diameter, circumference and area are shown:



16. After selecting any single line text on the drawing, the values of its height, rotation and oblique are shown:

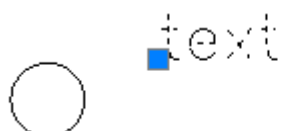

**To delete a field from a new toolbar:**

1. Place the cursor over the field:

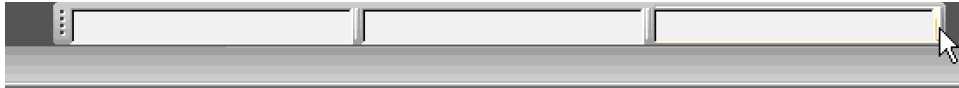

2. When the field is selected, press **ALT** and drag the field into the drawing area:

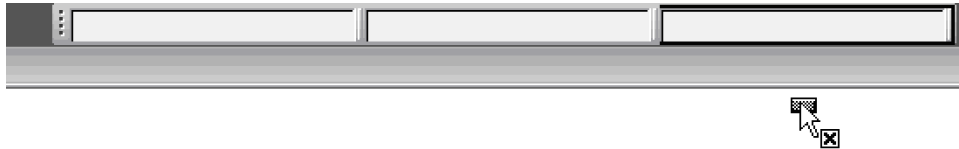

**NOTE:** The **Disable All** switches off the display of properties' values not only in the user fields, but in the fields of **Properties** and **Styles** standard toolbars.

## Drawing Explorer



Ribbon: **Manage – Palettes** >  **Drawing Tree**



Menu: **Modify** –  **Drawing Explorer**



Menu: **View – Toolbars** > **Functional** >  **Drawing Explorer**



Toolbar: **Properties** – 



Command line: **DRAWINGEXPLORER**



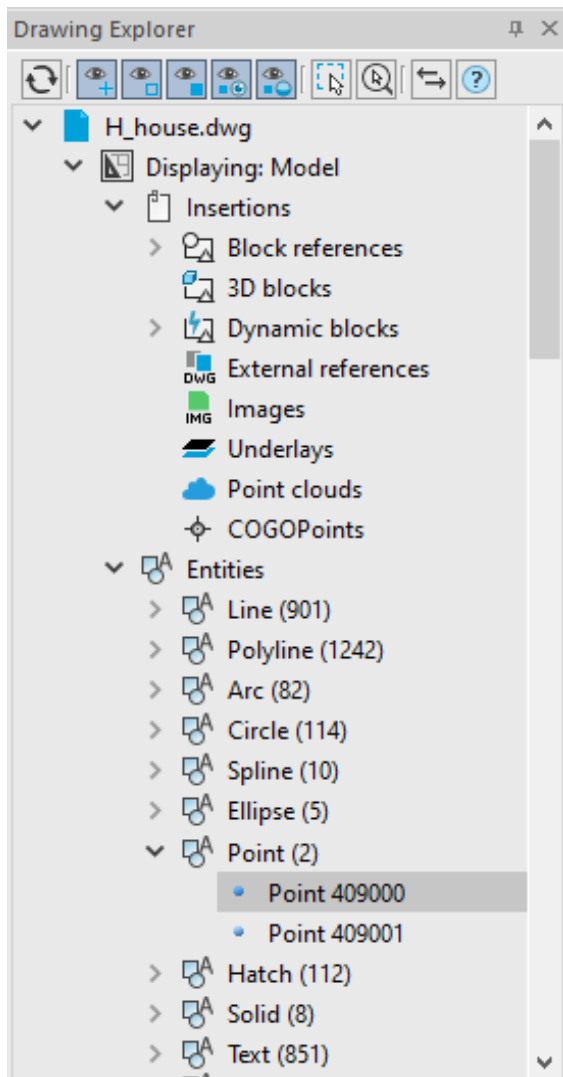

**Drawing Explorer** provides full information about all objects in drawing:

- graphic objects;
- block references, external references, raster images;
- parameters of drawing settings.

All changes in drawing reflect in Drawing Explorer immediately. You can separately get the information in Explorer (and also in a drawing area) about new objects and about objects changed since last saving.

You can open dialogs for editing parameters and properties of objects directly from Drawing Explorer.

The name of the current document is displayed in the root section of the dialog hierarchical structure. Which, in turn, contains two subsections: **Displayed** and **Drawing Settings**.

## *Objects in the current document space*

The **Displayed** section contains a hierarchical list of all occurrences and objects in the current document space — model space or paper space. Objects are grouped by type. The number of objects of this type in the current document space is given in parentheses.

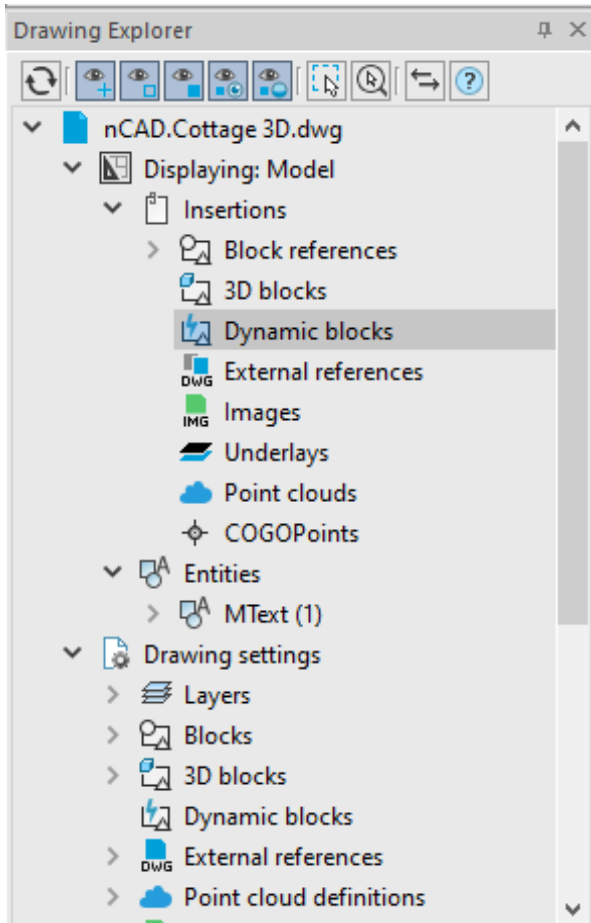

The **Insertions** subsection displays all Insertions of the current model or paper space: regular, dynamic, and 3D block inserts, xrefs, raster images, underlays, and point clouds.

The **Entities** subsection displays objects in the current space grouped by type.

If geopoints were imported to the file, a separate section will appear.

The context menu of drawing objects selected in the dialog structure contains commands for managing objects. The list of available actions depends on the type of object or group of objects. You can select objects in the drawing, pan, apply editing commands, turn display on and off in the drawing, delete.

Thus, for example, you can hide or make visible both an individual object and a group of objects. To make a previously hidden object visible on the screen again, select the **Visibility** item. For a group of objects - the **Show** item.

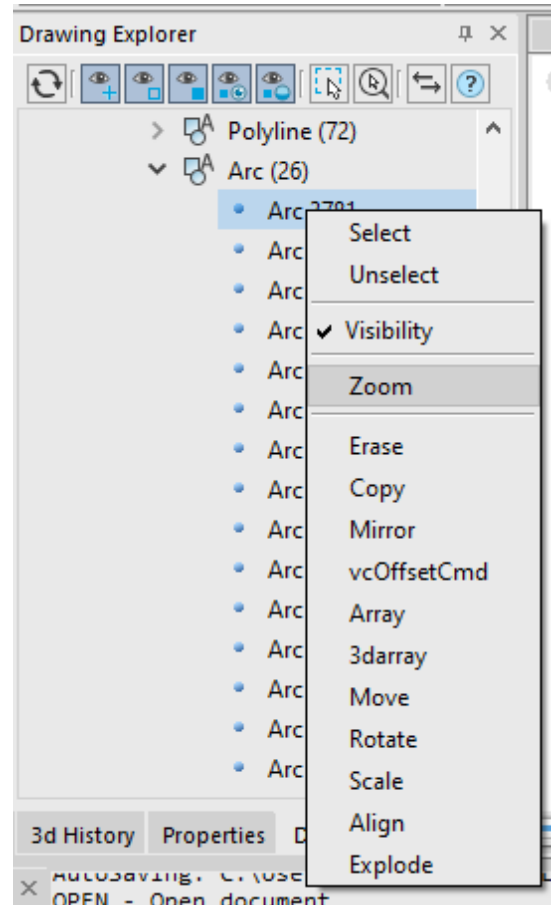
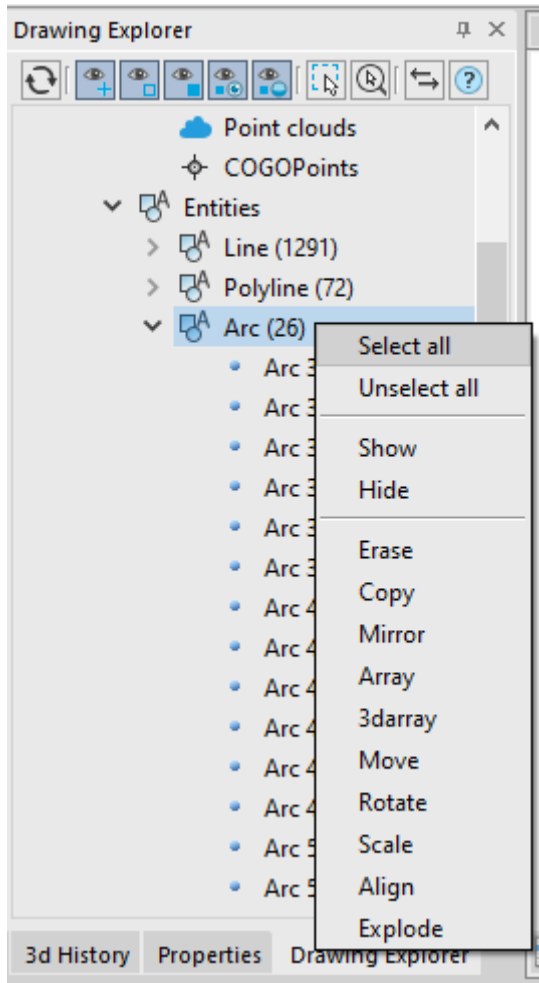

### Tools for control of displaying objects

At the top of the drawing explorer, there are buttons to control the display of objects in the explorer tree and in the drawing field. Initially, the tree of the drawing explorer contains a list of all objects:



**Refresh tree**

Renew information. All opened sections will be closed.

*Filters of displaying objects in the Explorer tree:*



**Show created objects**

Displays information about new objects in the current session of the drawing. In the Drawing Explorer such objects have a "plus" sign.

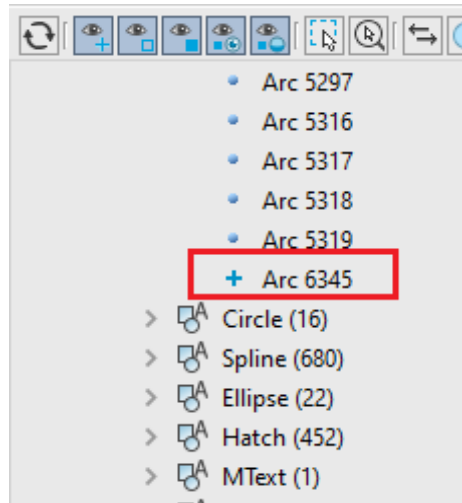

**Show modified objects**

Displays information about objects changed in the current session of the drawing. In the Drawing Explorer such objects have a "load" sign.

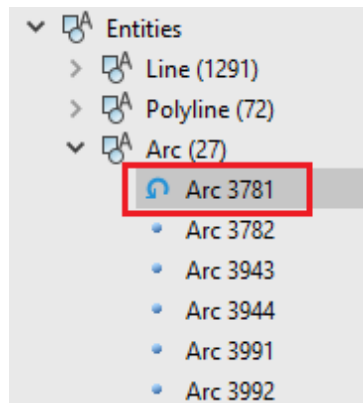

**Show resident objects**

Displays information about unchanged objects of the drawing. In the Drawing Explorer such objects have a "point" sign.

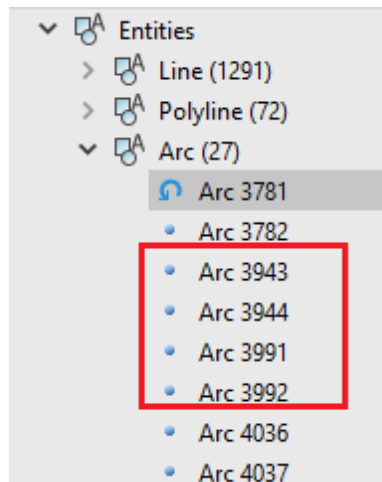

**Show visible objects**

Displays objects visible in the drawing in the Explorer.



**Show hidden objects**

Displays objects invisible in the drawing in the Explorer.

*Variants of displaying on the screen*



### Enable selection

Objects selected in Explorer tree marks with grips in a drawing area.





### Enable zoom and selection

Objects selected in Explorer tree marks with grips and places in the center of drawing area.



### Synchronize filters with drawings

Displays objects in a drawing area according to status of filters.

-  **Show new objects**
-  **Show modified objects**
-  **Show resident objects**

You can display objects hidden in the drawing field back by disabling one of these filters.

## Objects of the Current Document Space

The **Displaying** section contains a hierarchical list of all insertions and entities of the current document space – model or paper space. The number of insertions and entities in the current document space is given in parentheses.

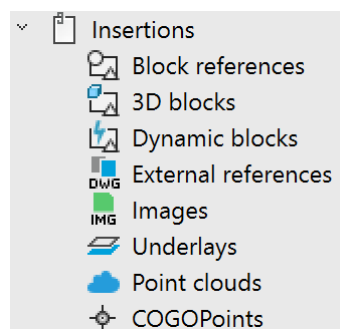

The  **Insertions** subsection displays all insertions of the current model space or paper space: insertions of regular, dynamic and 3D blocks, external references, insertions of raster images, underlays, point clouds, geopoints.

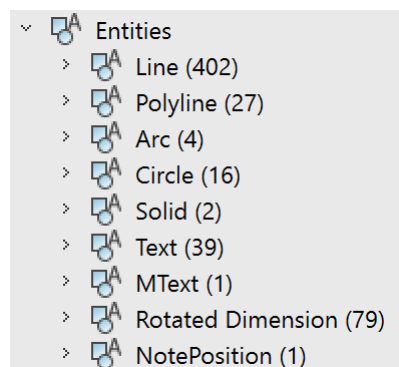

The  **Entities** subsection displays objects of the current space grouped by type.

Proxy objects (with and without graphical representation) are displayed with the  sign.

Annotative objects have the  sign:

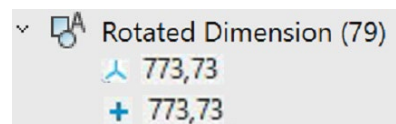

The context menu of insertions and drawing entities selected in the dialog structure contains object management commands. The list of available actions depends on the type of object or group of objects. You can select objects in the drawing, pan, apply editing commands, turn on and off display in the drawing, and delete.

Thus, for example, the following context menu commands are available for **Insertions – Point Clouds**:

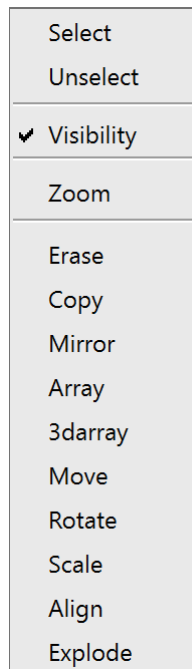

The [Explode the Cloud into Points](#) (**NG\_EXPLODE\_POINTCLOUD**) command appears if you have a license for the **Topoplan** module.

Also, using the context menu, you can hide or make visible both an individual object and a group of objects. To make a previously hidden object visible again on the screen, select the **Visibility** item. For a group of objects – the **Show** item.

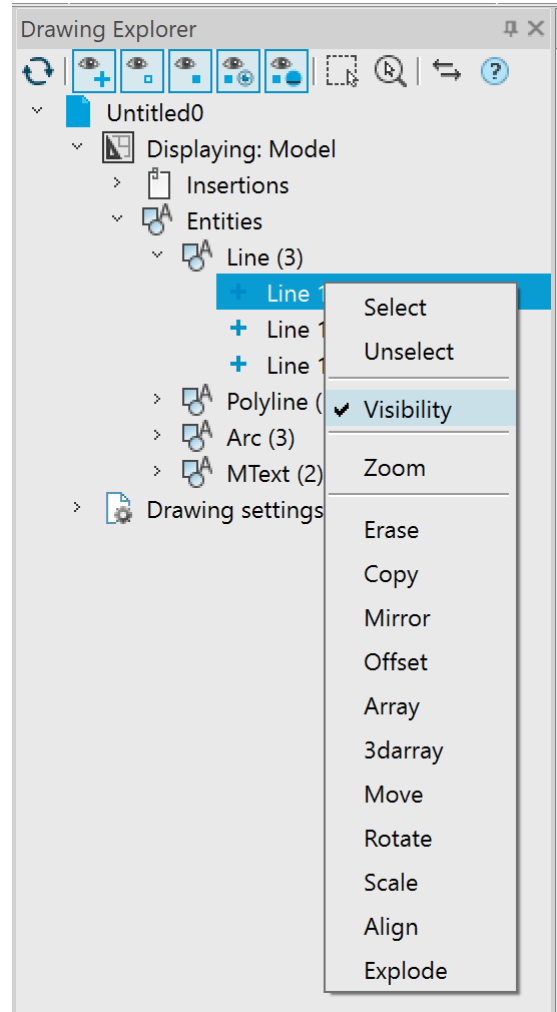
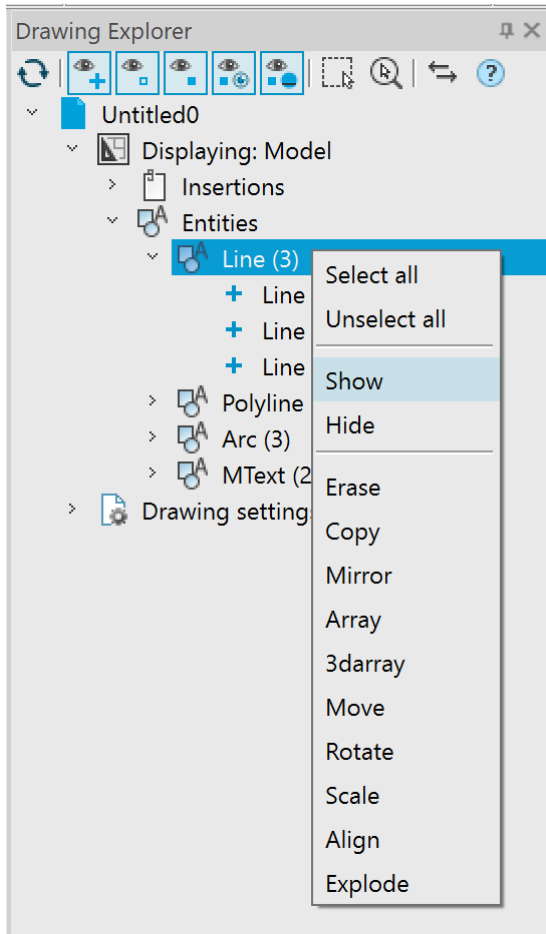

## Named Objects of a Drawing

The **Drawing Settings** section displays the list of named objects of a drawing: layers, blocks, xrefs, etc. grouped by object type.

Objects of different types have a context menu with own set of actions.

Usually, an element can be made current in a document, deleted, renamed.

A double-click on a named object sets it current in the document.

Pictograms of current objects are marked with a colored dot.

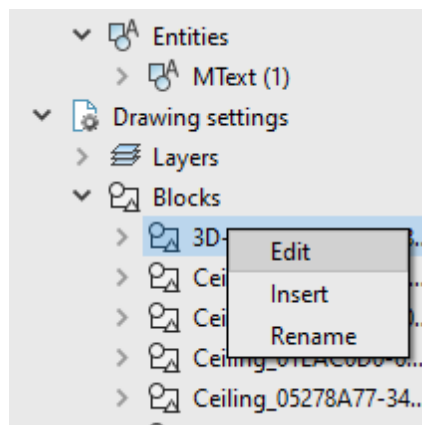

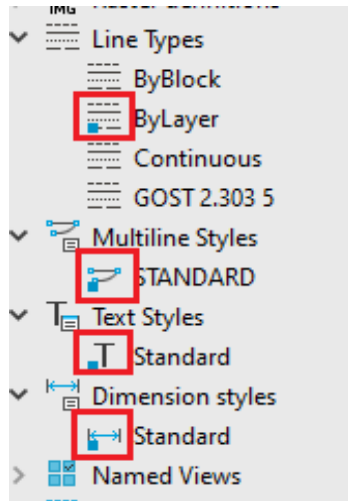

**NOTE:** Please, remember that when you set the selected sheet current, there will be a transition to this paper space with automatic update of the entire contents of the drawing explorer.

The context menu of the **Layers** group opens the Layers dialog:

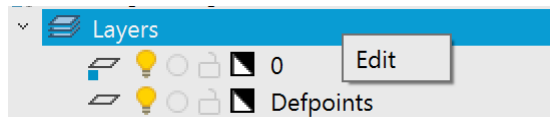

You can enable/disable, freeze/unfreeze and lock/unlock a layer in the **Drawing Explorer** by clicking on the corresponding icon while holding down the **CTRL** key. Changes will be immediately reflected in the drawing. Double clicking on a layer sets it as current.

Layers present on xrefs have the  icon.

In the context menu of layers, you can turn on the layer walk mode. In this mode, only the objects of the layer currently selected in the manager will be displayed in the drawing field. Exit from the layer walk mode is also performed through the context menu of layers.

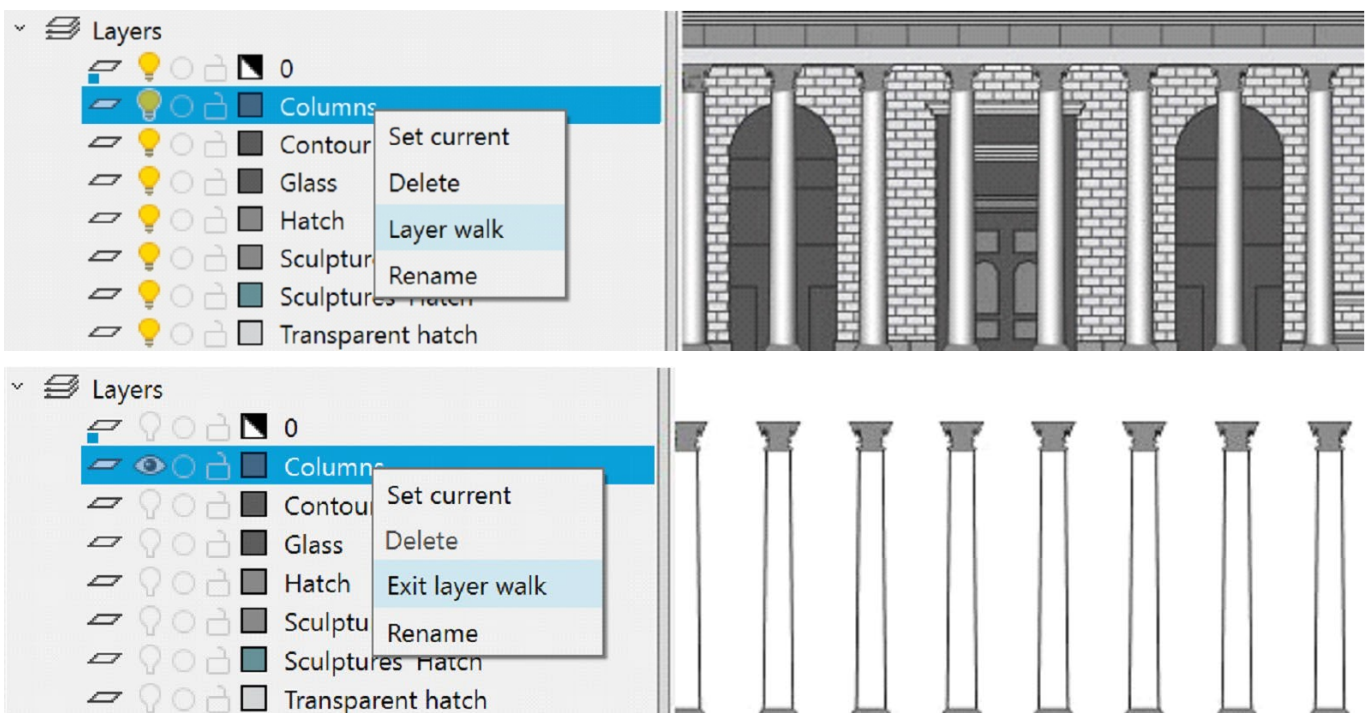



For **Blocks**, **3D Blocks**, **Dynamic blocks**, and **Rasters**, you can open a preview in the **Drawing Explorer** (hidden by default). To do this, move the cursor over the bottom border of the bar and expand the preview area:

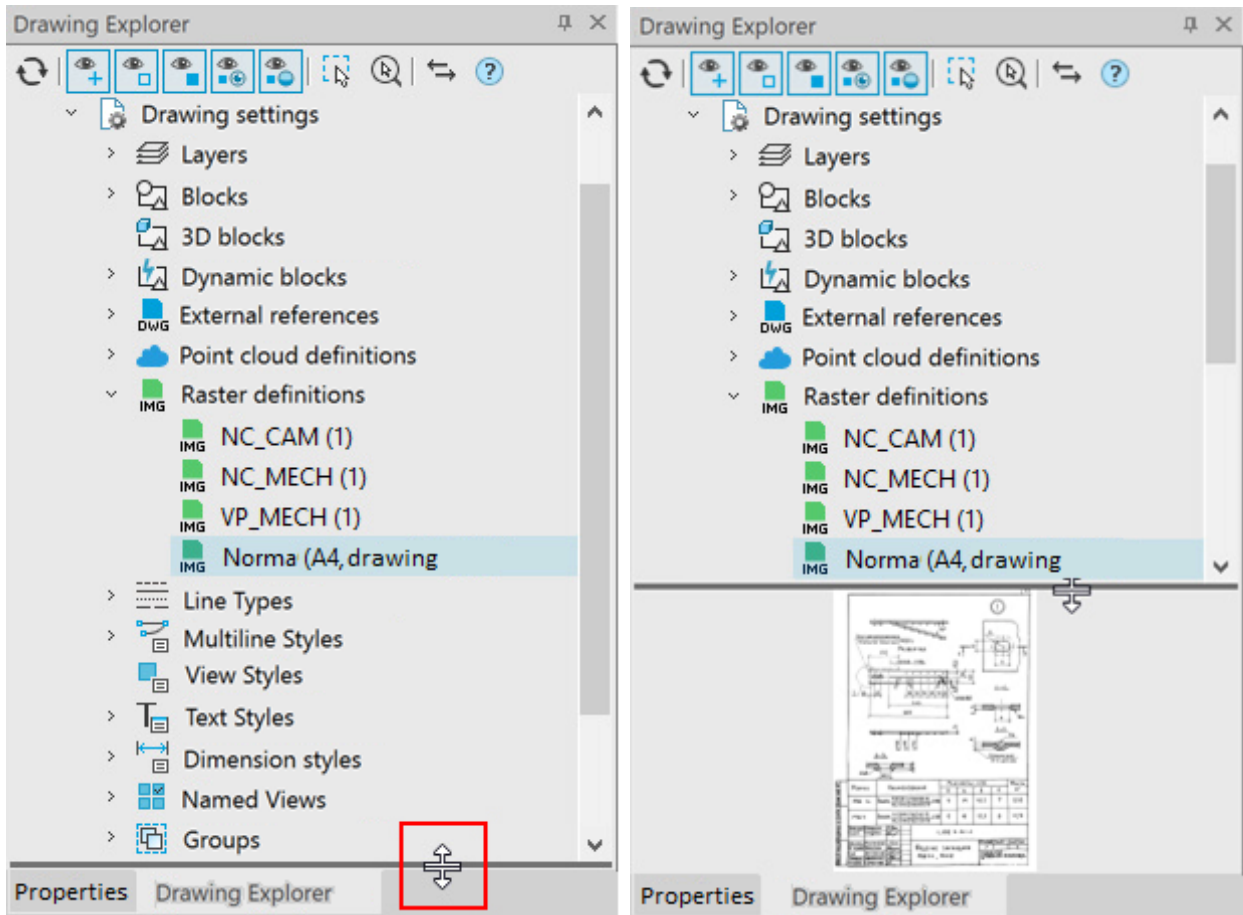

When you double-click on a block (raster) preview, the **Insert Block (Insert Raster)** dialog box opens.

In order to create a preview of a group, select the **Create preview list** command in the context menu of **Blocks**, **3D blocks** or **Dynamic blocks**:

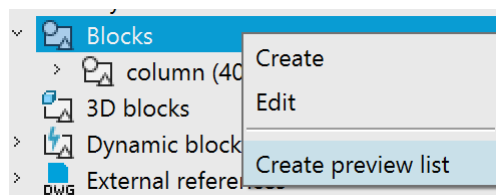

When changing blocks, to update the display, select the **Update preview list** command in the context menu:

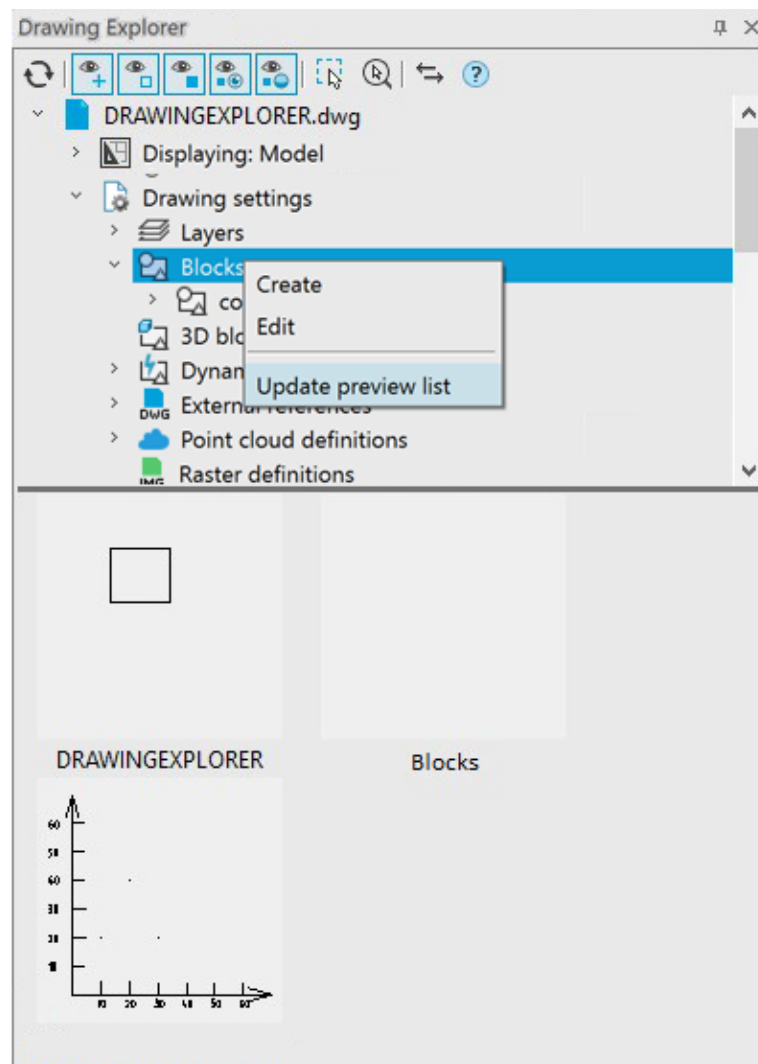

You can adjust the preview size and scale in the .ini file. The default size is 96x96, scale 1:1.

The context menu of the **External References** group allows you to:

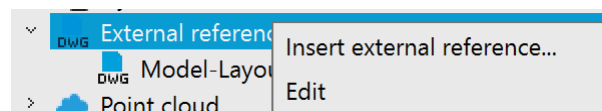

- **Insert external reference...** (XATTACH) by specifying the .dwg file;
- **Edit...** – reinsert references already existing in the drawing using the [Drawing Explorer...](#) toolbar (EXTERNALREFERENCES):

The external reference context menu allows you to open a file via the link in a separate tab or open the Insert external reference window to edit the insertion parameters:

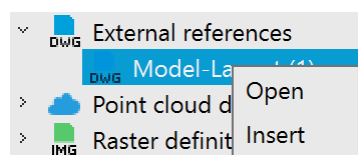

To manage named views, the context menu of the **Named Views** group allows you to **Create** or **Edit** existing named views (VIEW, -VIEW command):

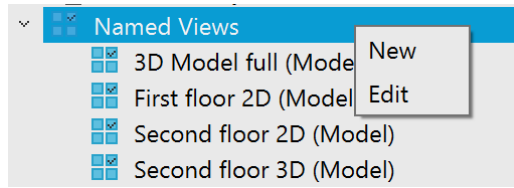

The named view's context menu allows you to **Set current**, **Remove** and **Rename** a view:

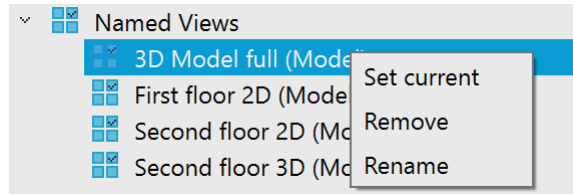

You can also set a view by double-clicking on a named view, which will auto-pan the view and display its boundaries with a red frame:

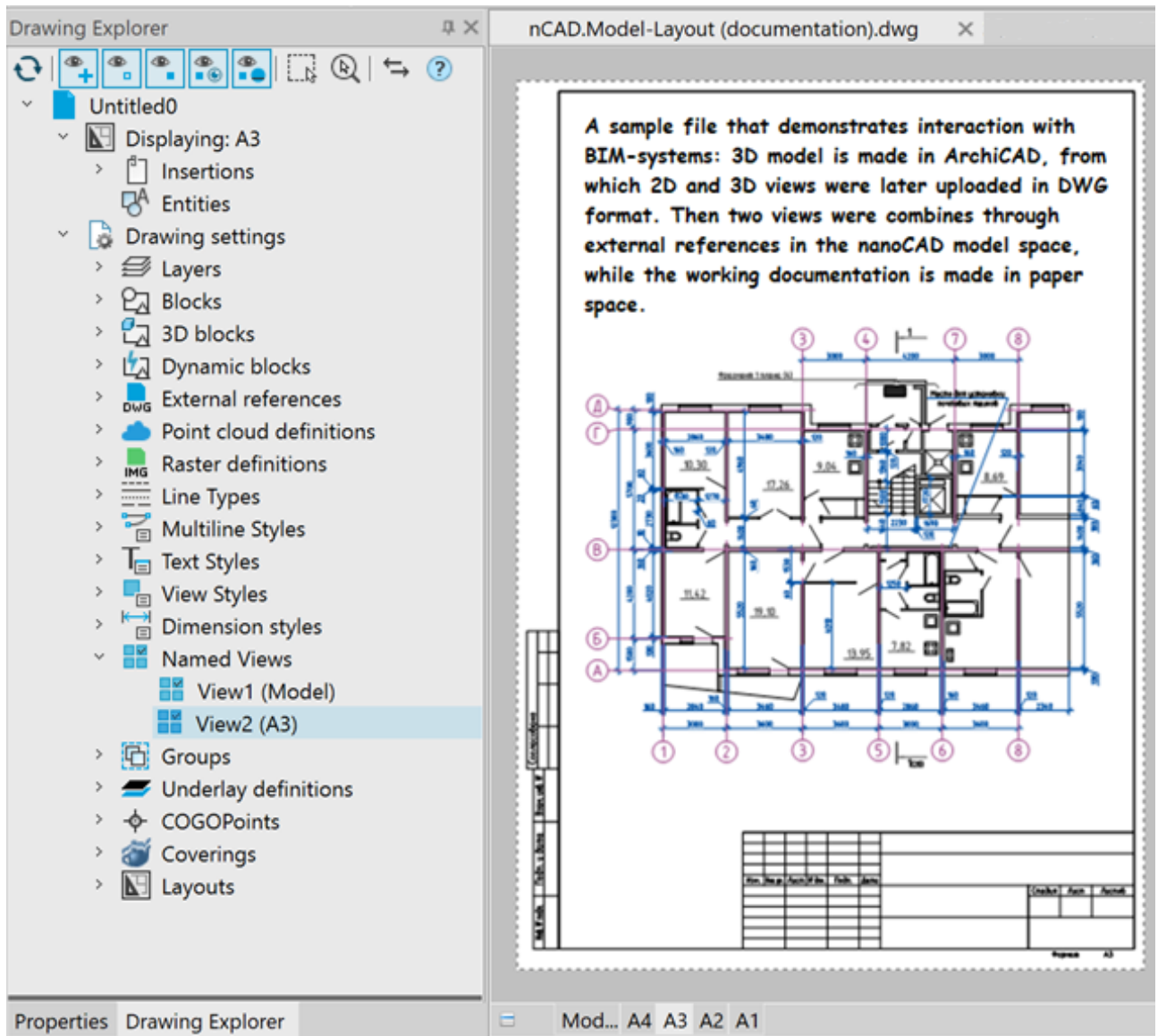

Work with **Groups** is described in the Using Drawing Explorer Bar to Work with Groups section.

Work with **Geopoints** is described in the Geopoints in the Drawing Explorer section.

## Select Color Dialog Box



Command line: **COLOUR, COLOR, COL**

The **Select Color** dialog box allows you to set the desired color for editing element: drawing object, dimension style, layer etc.

The dialog opens also when editing the color of layer or object by clicking **More Colors...** in drop-down list of colors:

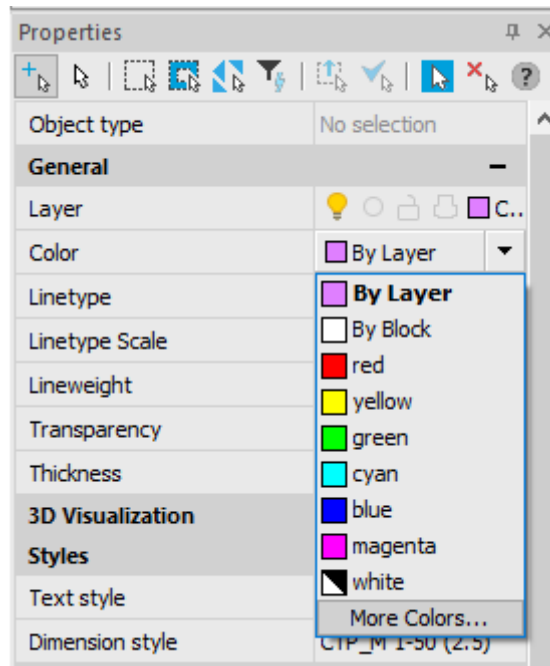

The dialog box contains two tabs: **Index Color** and **True Color**.

### Index Color Tab

The **Index Color** tab allows you to select the color from the nanoCAD color index palette.

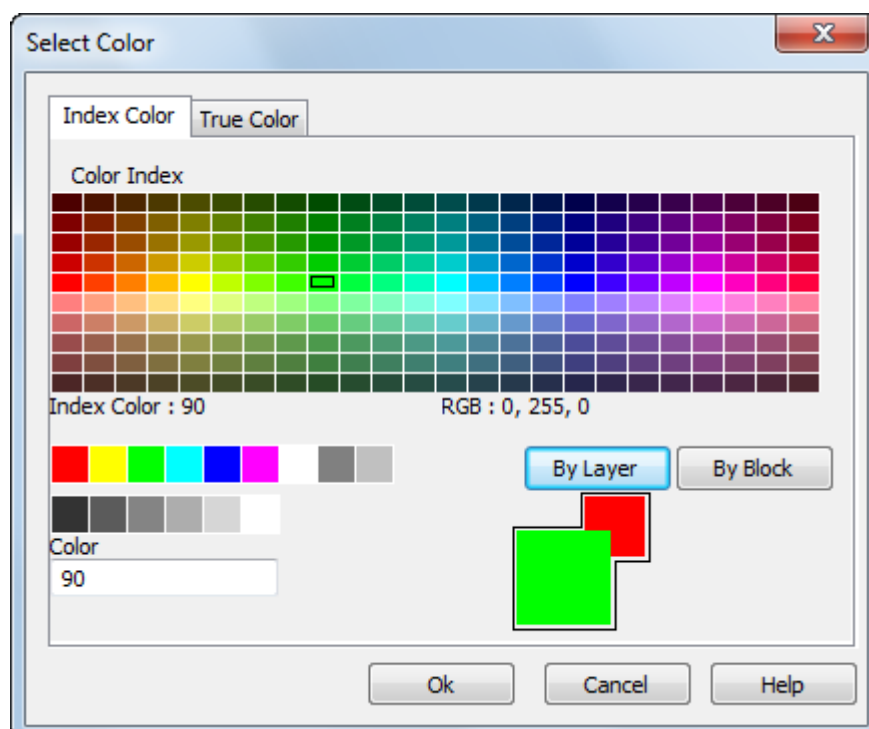

When you hover over a color, the **Index Color** indicates the color number (index), while the **RGB** indicates the RGB (red, green, blue) color value. Click a color to select it, or enter the color number or name in the **Color** box. Selected color will be displayed in the New Color swatch (big square).

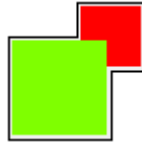

*Parametres:*

**Color Index palette**

Displays colors 10 through 249 selectable.

**Named colors palette**

Displays colors 1 through 9; these colors have names as well as numbers.



**Grayscale palette**

Displays colors 250 (black) through 255 (white); these colors are shades of gray.

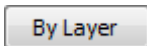

Specifies that new objects assume the color assigned to the layer on which you create them. When BYLAYER is selected, the color of the current layer is displayed in the Old and New color swatches.

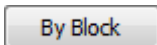

Specifies that new objects use the default color (white or black, depending on your background color) until you group the objects into a block and insert the block. When you insert the block into a drawing, the objects in the block inherit the current Color setting.

**Color field**

Specifies a color name, BYLAYER or BYBLOCK color, or an Color Index number of 1 through 255. The New color swatch shows the most recently selected color.

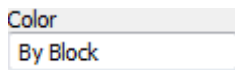

**Old Color and New Color Swatch**

Displays the previously selected color in a small square and the currently in a big square.



## True Color Tab

The **True Color** tab allows to select the color using true color palette, over sixteen million colors are available.

**Color model** drop-down list determines the contents of the entire tab and allows to select the color in RGB or HSL color scheme.

*RGB color model*

Colors can be broken down into components of red, green, and blue. The values specified for each component represent the intensity of the red, green, and blue components. The combination of these values can be manipulated to create a wide range of colors. Adjust the slider on the color bar or specify a value from 1 to 255 for every component.

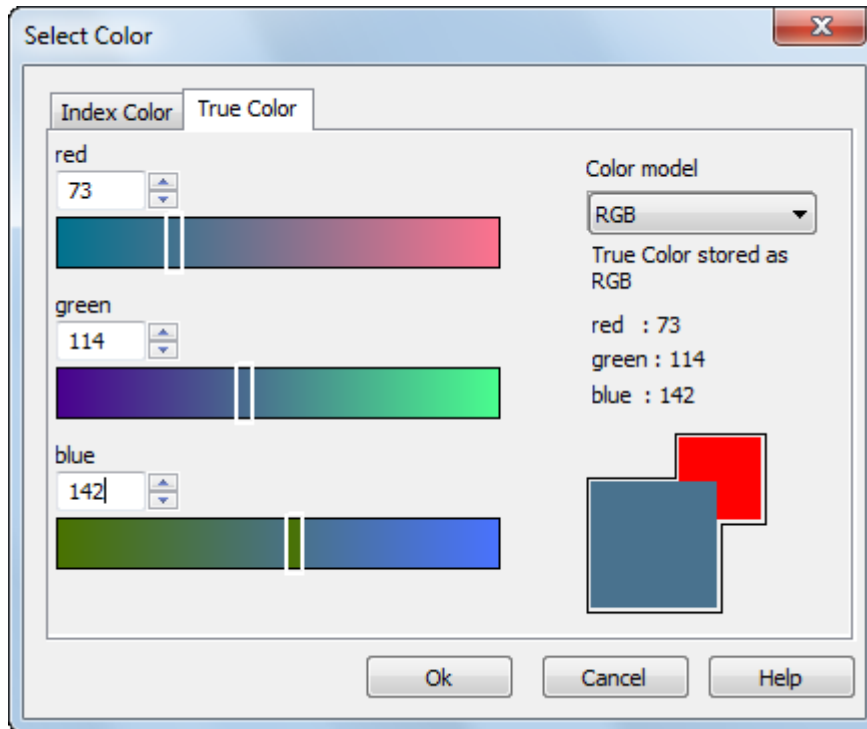

### *HSL color model*

The HSL color model allows to compose the color from hue, saturation and luminance components.

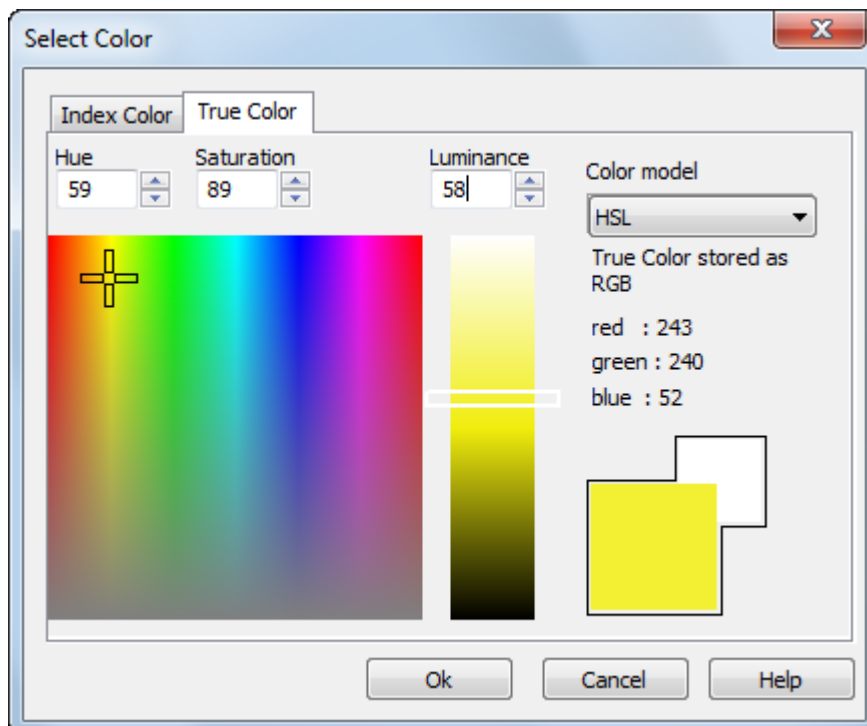

**Hue** specifies the hue of a color. Hues represent a specific wavelength of light within the visible spectrum. To specify a hue, use the color spectrum or specify a value in the Hue box. Adjusting this value affects the RGB value. Valid hue values are from 0 to 360 degrees.

**Saturation** specifies the purity of a color. High saturation causes a color to look more pure while low saturation causes a color to look washed-out. To specify color saturation, use the color spectrum or specify a value in the Saturation box. Adjusting this value affects the RGB value. Valid saturation values are from 0 to 100%.

**Luminance** specifies the brightness of a color. To specify color luminance, use the color slider or specify a value in the Luminance box. Valid luminance values are from 0 to 100%. A value of 0%

represents the color black, 100% represents white, and 50% represents the optimal brightness for the color. Adjusting this value also affects the RGB value.

## Distributing Objects by Layers

The main advantage of CAD is organizing a document by layers. Layers are used to separate, sort and edit drawing objects.

To explain the function of layers we will use an example with tracing paper. Layers in the drawing are like transparent tracing papers. One tracing paper (or layer) contains the floor plan, the second – water supply system, the third – heating, the fourth – electric power supply etc. By combining different layers (tracing papers), you can create the required sets of design documentation.

Placing different groups of objects on separate layers helps to order and simplify many of the operations of drawing management. For better organization and operation of data, drawing elements of one type are placed on the same layer. For example, auxiliary lines are placed on a separate layer to facilitate and accelerate their removal. Dimensions, text objects, hatches etc. can be placed on separate layers.

Every newly created object contains by default the *0* layer, which cannot be deleted or renamed. The drawing must contain at least one layer because any graphic object must be placed on a layer (it is often said that an object belongs to a layer).

It is not recommended to create all drawing objects on the *0* layer. It is recommended to create a new layer for the correct organization of graphic objects.

When the first dimension is set, the *Defpoints* utility layer is created; this is where the control points of dimensions are set. The display view of these points is not changed with the **DDPTYPE** command. The *Defpoints* layer is never printable.

When an object is created, its properties are taken from the layer where it is placed (if **By layer** is selected).

If you specify a particular color, type and line weight instead of the **Bylayer** parameter in the **Color**, **Linetype** and **Line Weight** drop down lists on the **Properties** panel, these values will be applied to all newly created objects on the layer.

To create a new object you do not need to specify its properties every time. You switch to the required layer and create the object.

Distributing objects by layers helps to edit objects' properties separately. By blocking separate layers, you can prevent editing of objects placed on these layers if you do not want accidental changes. Layers can be switched on/off, visible/invisible. Every layer can be made printable or unprintable.

An active layer, selected for working with, is called *current*. By default, newly created objects are placed on the current layer.

Some frequently used parameters for managing layers and their properties are placed on the **Properties** toolbar:

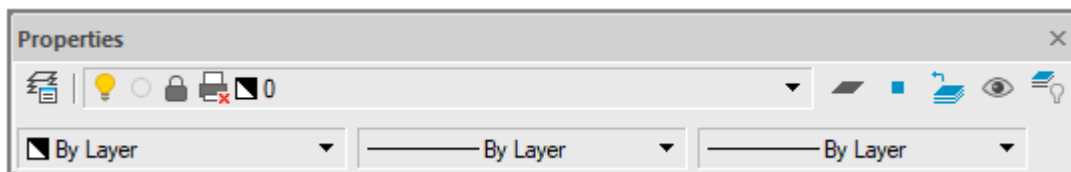

And in the **General** section of the **Properties** bar:

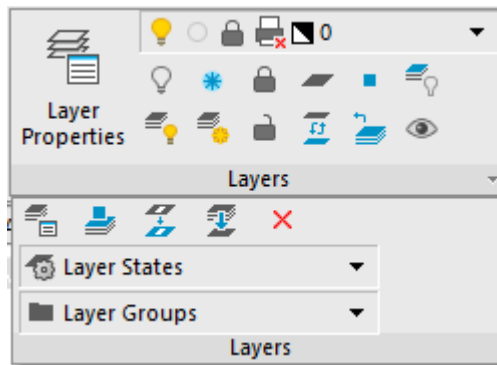

The **Layer** drop down list allows reassigning of the **current** layer, and also switch on/off, freeze/unfreeze and block/unblock a layer:

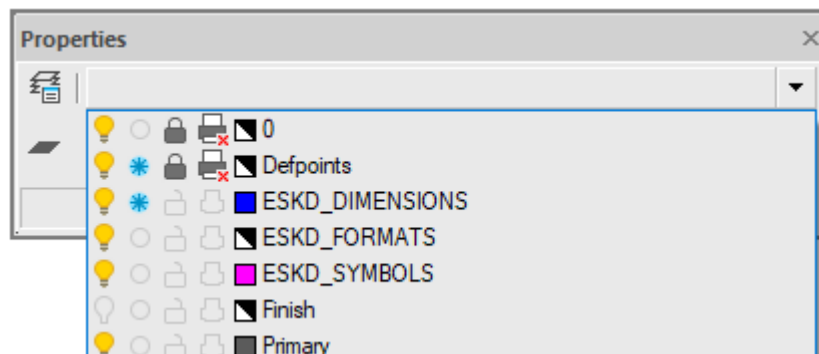



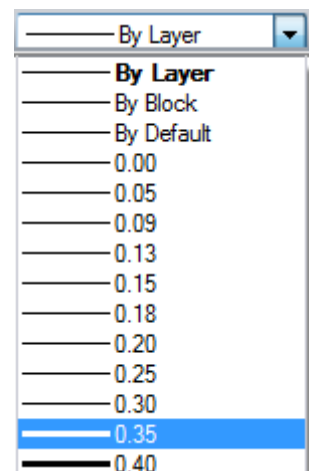
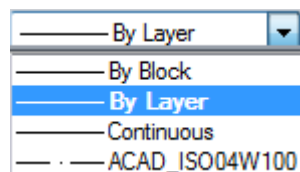
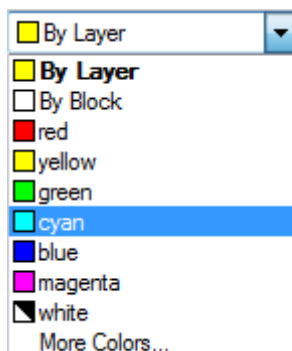



**Color**, **Line type** and **Line weight** drop down lists are used to change the properties of a selected layer quickly:



The **Layer**  button on the **Properties** toolbar opens the **Layers** dialog box where you can create, delete, rename and do other operations with layers.

## Layers

-  Ribbon: **Home – Layers** >  **Layer Properties**
-  Menu: **Format –**  **Layers...**
-  Toolbar: **Properties –** 
-  Command line: **LAYER, LAYERS**



The **Layers** dialog box is used to manage layers and their properties:

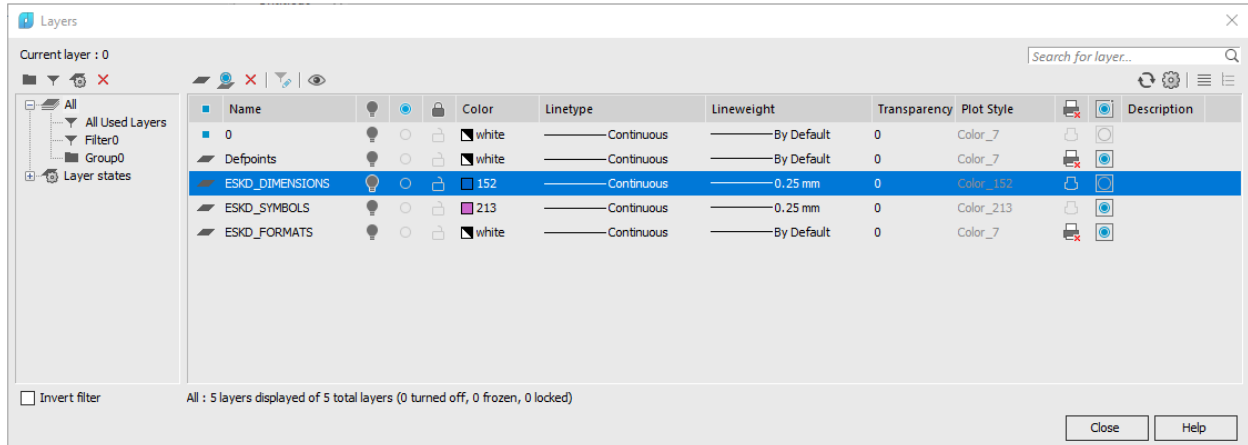

The **Layers** dialog is modal, that is, while the dialog is displayed on the screen, all relevant information on layers is displayed in it (and not on the functional bars) and changes outside the dialog are not taken into account.

There is a window in the left part of the dialog box with a **category tree**. In general, a **category tree** consists of the following elements:

- **All**
- **All Used Layers**
- **All Layers without xrefs;**
- **External references**
- **Filters**
- **Groups**
- **Configurations**

The right part of the dialog box shows the list of layers for the selected element in the category tree.

Below the dialog box title:

Current layer : Default – the current layer is shown.





Search for layer by name.

Below the layer list box there is information about the displayed layers, the total number of layers and the number of disabled, frozen and locked layers.

All : 11 layers displayed of 11 total layers (4 turned off, 2 frozen, 2 locked)

### Parameters:

#### Tree categories window







-  [Add group](#) The button adds groups of layers.
-  [Add filter](#) The button adds a filter.
-  [Add layer state](#) The button adds layer states.
-  Delete The button deletes the tree's elements.

**Remark:** Short description of the layer's configuration. The parameter is displayed above the **Invert filter** when you select the layer's configuration in the tree.

**Invert filter** The Inversion mode for the display of layers in the layer's list.

### List of edited layers

#### Buttons

-  [Add](#) The button adds a new layer.
-  **Add Layer VP Frozen in All Viewports** Adding a layer frozen in all viewports.
-  [Delete](#) The button deletes a selected layer.
-  [Edit filter](#) The button edits selected filter.
-  [Layer walk](#) The button turns the single layer mode on.
-  **Refresh** Regeneration
-  **Layer settings** Controlling the display parameters in the **Layers** dialog box and properties of layers included in xrefs.

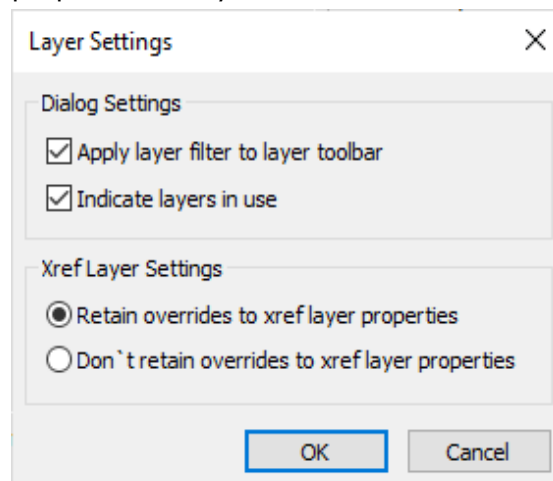

**Apply layer filter to layer toolbar** – whether to consider or not the current filter when displaying the list of layers on the toolbar

**Indicate layers in use** – whether to mark or not the used layers in the layer manager. Recalculation occurs when you open the manager, add/remove a layer. If this option is enabled, opening the layer manager on large files may take longer than expected. In previous versions of the program, recalculation was always performed.

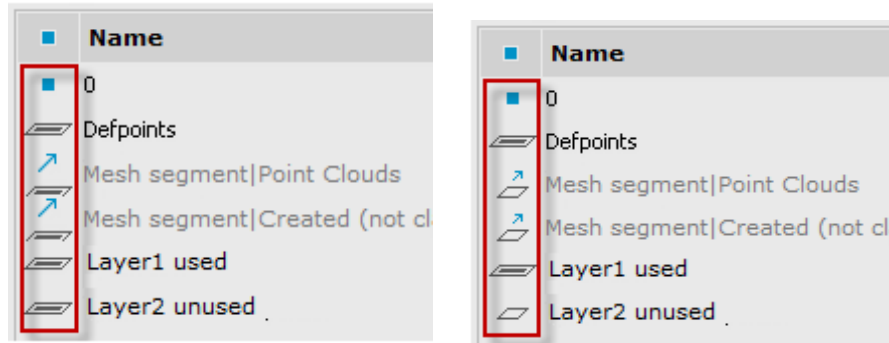

**Retain/Don't retain overrides to xref layer properties** – whether to retain or not the changes in properties of xref layers.



**Collapse Layer Filter Tree**



**Expand Layer Filter Tree**

Buttons to control the display of layers filter tree.

### Columns



**Status**

Column displays the current layer.



Current layer



Layer contains objects.



Layer contains objects.



Layer contains no objects.



Xref layers.



Layer contains objects and properties override is enabled in the viewport.

**Name**

Column displays the layer's name.



Column displays the icon for visibility of layers.



Column displays the icon for freezing of layers.



Column displays the icon for locking a layer.

**Color**

Column displays an icon for the layer's color.

**Line Type**

Column displays the layer's line type.

**Line weight**

Column displays the layer's line weight.

**Transparency**

Displays the layer transparency.

**Plot style** Column displays the layer’s plot style.



Column displays the icon permitting printing.



Column displays frozen layers in the current viewport.

**Description** Short information about the layer.























Double-click by the left mouse button on the column header separator automatically changes the columns width.

### *Layers in paper space*

When working in paper space, a message appears in the title of the **Layers** dialog box – *Layers (on Layout)*

When there is a current layout **VIEWPORT**, the title will look like - *Layers (on Viewport)*

Columns with information about layers parameters in the viewport are added to the list of layers box.

		Color	Linetype	Lineweight	Transparency	Plot Style
		 white	———— Continuous	———— By Default	0	Color_7
		 blue	———— Continuous	———— By Default	0	Color_5
		 red	———— Continuous	———— By Default	0	Color_1
		 white	———— Continuous	———— 0.50 mm	0	Color_7
		 yellow	———— Continuous	———— By Default	0	Color_2
		 blue	———— Continuous	———— By Default	0	Color_5
		 red	———— Continuous	———— By Default	0	Color_1



Displays the icon of layer freeze in the current viewport.

**Viewport Color**

Displays the layer color in the current viewport.

**Viewport Linetype**

Displays the layer linetype in the current viewport.

**Viewport Lineweight**

Displays the layer lineweight in the current viewport.

**Viewport**

**Transparency**

Displays the layer transparency in the current viewport.

**Viewport Plot style**

Displays the layer plat style in the current viewport.

### *PDF Underlay layers*

If PDF underlays are present in the drawing, information about them will appear in the categories tree.

If the selected PDF underlay contains layers, their list will be reflected in the dialog box. You can control visibility of underlay layers by turning the sign  on or off.

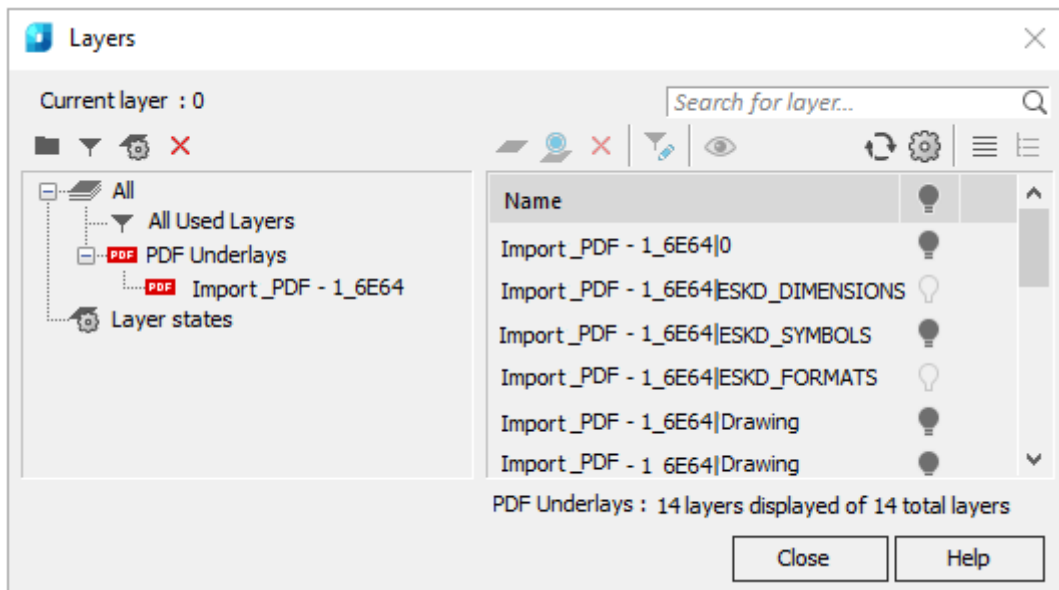

## Editing a Layer's Parameters

### To Select Layers in the Dialog Box

Click on a layer to select it.

You can edit the parameters of several selected layers at once.

With **SHIFT** pressed, select the first and the last layer in the list. These layers and any layers between them will be selected.

With **CTRL** pressed, you can select individual layers from the list.

All layers in the list are selected by the **Select all** context menu command. The **Unselect all** command cancels the selection of all layers selected in the list.

### Search for Layers by Name

The **Search for layer** field in the top right part of the dialog box is designed for quick search for layers by name

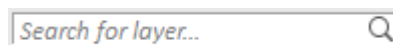

#### To search for layers by name:

1. Enter text or part of the text in the field to search. You can use special symbols.

As you enter, only the elements the name of which contains the entered phrase remain in the list of layers.

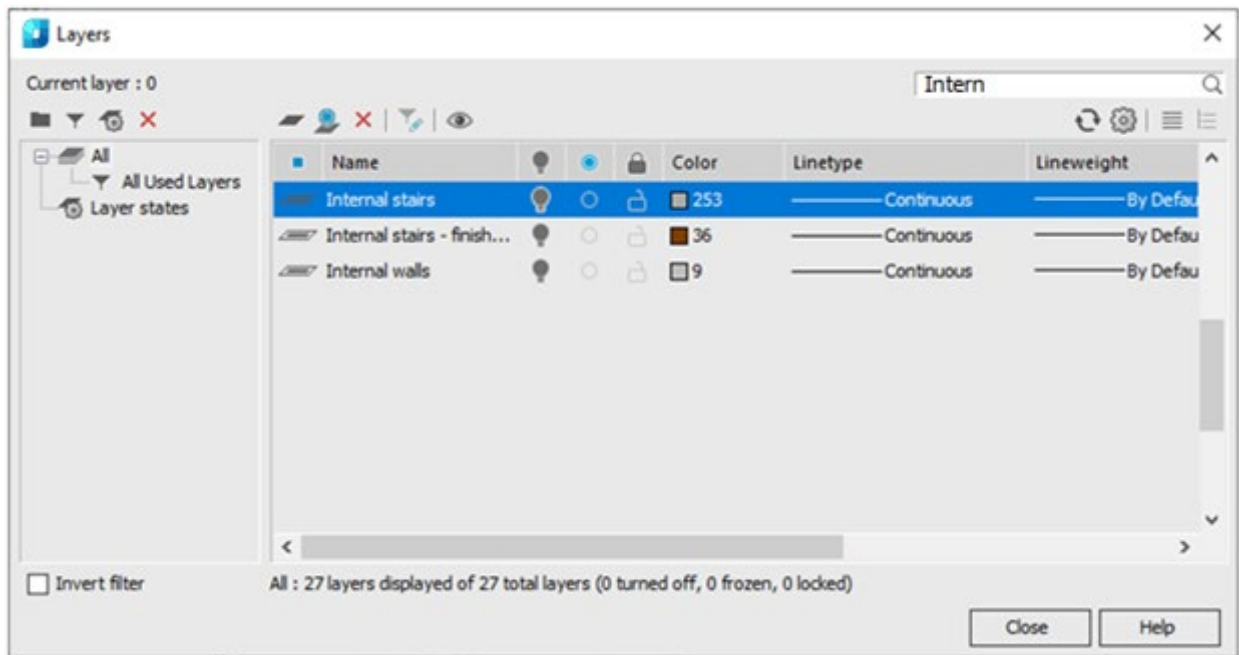

The field button  resets the search results.

## To Sort Layers by Property

A list of layers can be sorted by any parameter. To sort a list of layers, click on the parameter column title.

For example, click on the **Color** title and all layers in the list are sorted by color. Clicking on the title again reverses the order of the sorted layers:

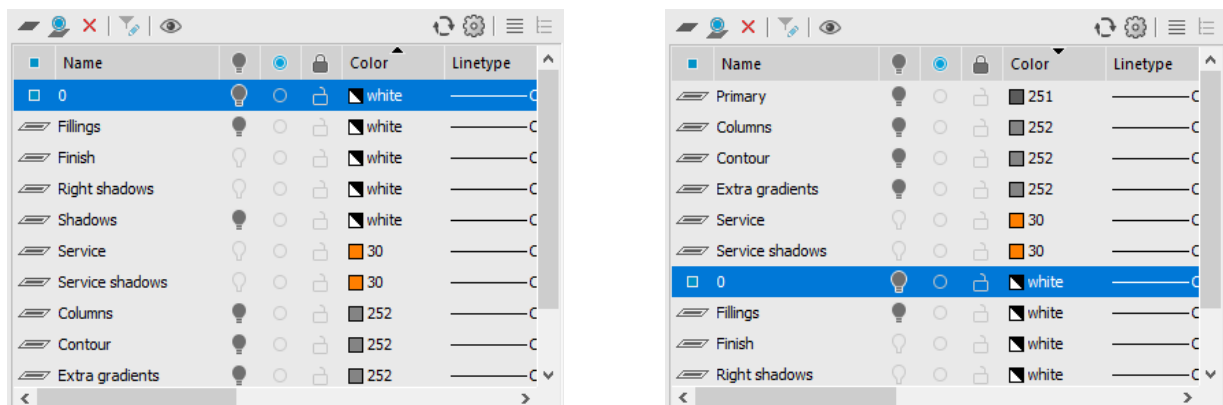

The sorting direction is indicated by the arrow in the header of the sorted parameter.

## Specifying the Color, Type and Width of Lines in the Layer

In the **Layers** dialog it is possible to specify all the properties that can be inherited by the objects created on it. Ensure the **By layer** value is set in the corresponding boxes of the object properties.

**Color, type and weight of lines can be specified for several layers at once:**

1. Select a layer or several layers to change the properties.
2. Click on the required parameter in the column.
3. Select the value from the list.

## Creation of a New Layer

A newly created layer has default properties. After a new layer is created, you can change its properties.

### To create a layer:

1. Click button  **Add**.

A new layer with the name *New Layer (N)* appears in the list. The default name for the new layer can be changed.

## Renaming a Layer

### To rename a layer:

1. Select layer in the dialog box.
2. Click name of the layer.
3. Enter the new name.
4. Press **ENTER**.

## Removing a Layer

Only layers not used in the document can be deleted. The current layer, even if it is not used cannot be deleted.

### To delete a layer:

1. Select layer in the dialog box.
2. Click the **Delete**  button.
3. You can delete several unused layers at once.

### To delete several layers:

1. Select **All Used Layers** in the categories tree.
2. Switch on the **Invert filter**  **Invert filter** parameter.

Select all sorted unused layers and select the **Delete**  button or **Delete** command from the context menu.

## Removing of Used Layers

1. Select layer(s) in layer list.
2. Click the **Delete**  button.

**Delete used layers** dialog box appears when you delete used layers:

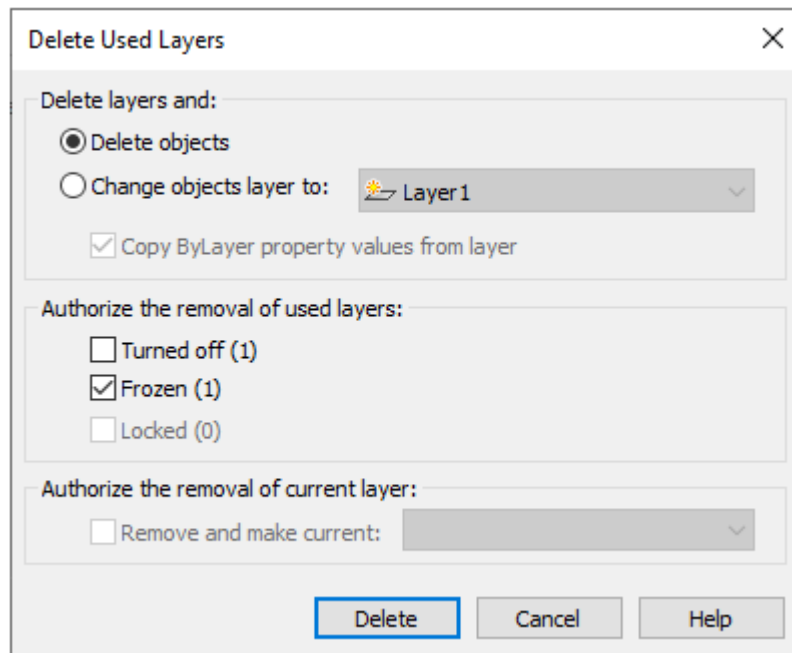

**Delete layers and:**

**Delete objects**

**Change objects layer to:**

**Copy ByLayer property values from layer**

Authorize the removal of used layers:

Authorize the removal of current layer

**Remove and make current**

Selects the action with objects from deleted layer.

Deletes selected layer with all objects.

Moves objects of deleted layer. Objects may be moved to new *LayerN<sup>o</sup>* or existing layer from the list.

Sets **ByLayer** properties for moved objects.

Permits to delete Turned off, Frozen, Locked layers. Brackets show the number of selected layers with property. These options are available only if the layers being deleted contain these properties. The number of selected layer with this property is shown in brackets

Permits to delete the current layer.

Selects the current layer from the list, when removing a previously set.

3. click **Delete**.

If the selection for deletion contains layers that cannot be deleted, information on them is presented in the **Delete Layers** dialog:



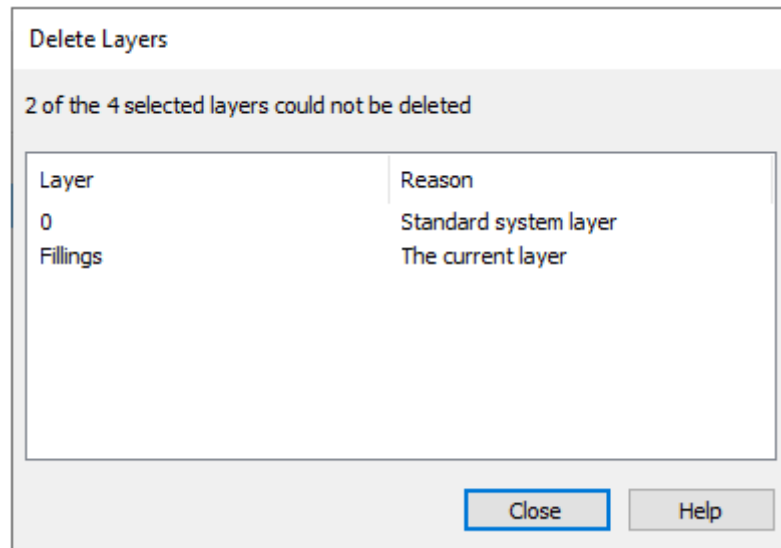

**NOTE** You can delete the Defpoints service layer using the **LAYDEL** command.

## Making a Layer Active

*To make a layer active:*

1. Select a layer in the **Layers** dialog box.
2. Click in the column icon of the selected layer. The  icon means that a layer is current.

## Controlling Layer Visibility

Objects with visibility switched off are not displayed on layers and are unprintable, but are used in regeneration of a drawing. When layers are switched on/off, regeneration is not performed. It is recommended to switch on/off layers when you need to do it frequently and not for a long time. In other cases it is better to freeze them.

Visible layers are marked with  icon. The  icon means that visibility of the layer is switched off. Visibility can be switched off for several layers at once. Visibility of the current layer cannot be switched off.



*To switch on/off visibility of a layer:*

1. Select one or several layers in the list.
2. Click the  icon of any selected layer to switch them off

**NOTE:** You can control visibility of drawing objects not only by switching visibility of the layer they lie on, but also directly by using the commands to hide and isolate objects.

## Freezing a Layer

Objects placed on frozen layers are not displayed on the screen and are unprintable and not used in regeneration of the drawing. You can freeze unused layers to make display and regeneration operations faster. But freezing a layer causes regeneration of the drawing, which takes time. Freeze layers if you only do it occasionally or you want to freeze the layers for a long time. In other cases it is better to switch them off.

Frozen layers are marked with  icon, while unfrozen layers are marked with .

You can freeze and unfreeze several layers at once. The current (  ) layer cannot be frozen.

**Freezing or unfreezing a layer to edit it:**

1. Select one or several layers in the list.
2. Click the  icon of any selected layer to freeze them all.

**Freezing Layers in the Viewports of a Layout**

Layers can be frozen in separate viewports of a layout. You can get different displays of the same objects in different viewports without creating additional geometry. For example, you create two layout viewports for the same object and freeze the layer with design elements in the second viewport:

Frozen layers from the current viewport are marked with  icon.

When the viewport is active, then icon is added to the **Properties** toolbar.

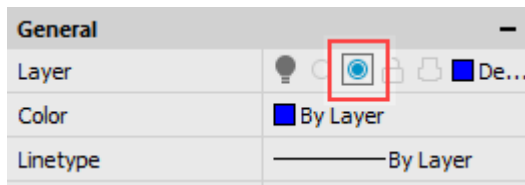

Viewport with unfrozen layers

Viewport with frozen layer of design elements

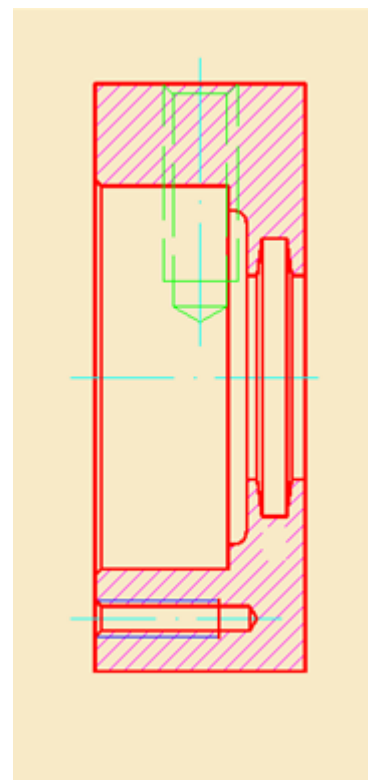
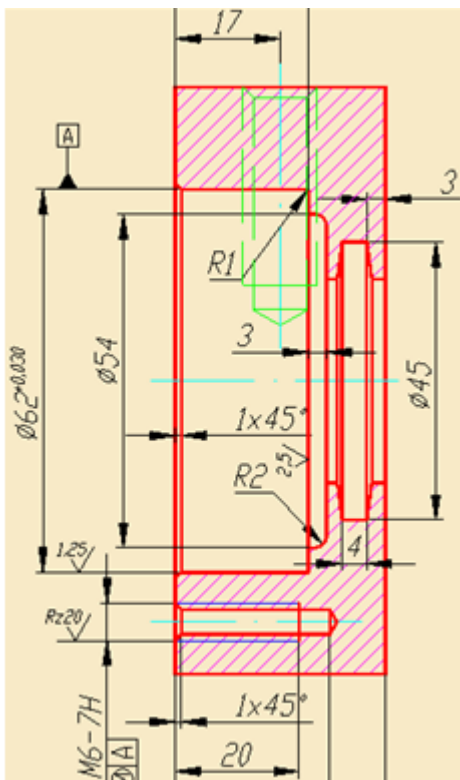

**To freeze layers in a layout viewport:**

1. Switch to layout with required viewport.
2. Double click this viewport to make it active.
3. Open the **Layers** dialog box and select all layers that should be frozen.
4. Click the  icon of any selected layer to freeze the selected layers.

5. Close the **Layers** dialog box.

The layer will be frozen in the current viewport, but will remain unfrozen in all other layout viewports. It will not be printed only in this viewport.

#### *To freeze a layer in all VPs:*

1. Open the **Layers** dialog and select all the layers that should be frozen on all viewports.
2. Open the context menu by right-click on the selected layers and select the **VP Freeze Layer > In All Viewports** command.
3. Close the **Layers** dialog.

Layers will be frozen and invisible in all viewports.

#### *To freeze a layer in all VPs except the current one:*

1. Activate the viewport by double-clicking on it with the left mouse button.
2. Open the **Layers** dialog and select in it all the layers that should be frozen on all viewports except the current one.
3. Right-click on the selected layers to open the context menu and select the **VP Freeze Layer > In All Viewports Except Current** command.
4. Close the **Layers** dialog.

Layers will be frozen and invisible in all viewports except the current one.

You can also use the **LAYVPI** command to freeze a layer on all layout viewports except the current one.

#### *To thaw a layer in all VPs:*

1. Open the **Layers** dialog and select all the layers that should be thawed on all viewports.
2. Right-click on the selected layers to open the context menu and select the **VP Thaw Layer in All Viewports** command.
3. Close the **Layers** dialog.

The layers will be thawed and visible in all viewports of all layouts.

### **Command to manage frozen layers in individual viewports**



Command line: **VPLAYER**

#### *Command prompts and options:*

Enter an option or [?/Freeze/Thaw/rEset/New\_frozen\_layers/Default visibility]:

? Shows the list of layers frozen in the selected viewport.

Freeze – freezes layers in one or more viewports.

Enter layer name(s) to freeze or  
<specify layers by selected  
objects>

Enter names of layers or select layer objects  
in the current viewport.

Viewports  
[All/sElect/Current/Exclude  
current] <Current>:

Select viewports for freezing specified layers.  
sElect option allows you to specify viewports  
in the drawing.

Thaw – thaws one or more layers in one or more viewports.

Enter layer name(s) to thaw:

ENTER names of layers.

Viewports  
[All/sElect/Current/Exclude  
current] <Current>:

Select viewports for thawing specified layers.  
sElect option allows you to specify viewports  
in the drawing.

**rEset** – sets visibility of one or more layers in selected viewports according to default visibility of layers.

Enter layer name(s) to reset or  
<specify layers by object  
selection>:

Enter names of layers or select layer objects  
in the current viewport.

Viewports  
[All/sElect/Current/Exclude  
current] <Current>:

Select viewports for resetting specified layers.  
sElect option allows you to specify viewports  
in the drawing.

**New frozen layers** – creates new layers frozen in all viewports.

Enter names of new layers frozen  
in all viewports:

Enter names of layers.

**Default visibility** – freezes or thaws specified layers for all new viewports.

Enter layer name(s) to change new  
viewports visibility <specify  
layers by object selection>:

Enter names of layers or select layer objects  
in the current viewport.

Visibility state in new viewports  
[Frozen/Thawed] <Thawed>:

Select visibility state of selected layers in new  
viewports.

Only two options are available in **VPLAYER** command for model space: **New frozen layers** and **Default visibility**.

## ***Redefinition of Layer's Properties in Viewports***

Redefinition of layer's properties is a way to display objects in different viewports of layout with different properties (color, type and line weight) without changing properties with "ByLayer" or "ByBlock" values.

A color of axes lines is changed in the right viewport:

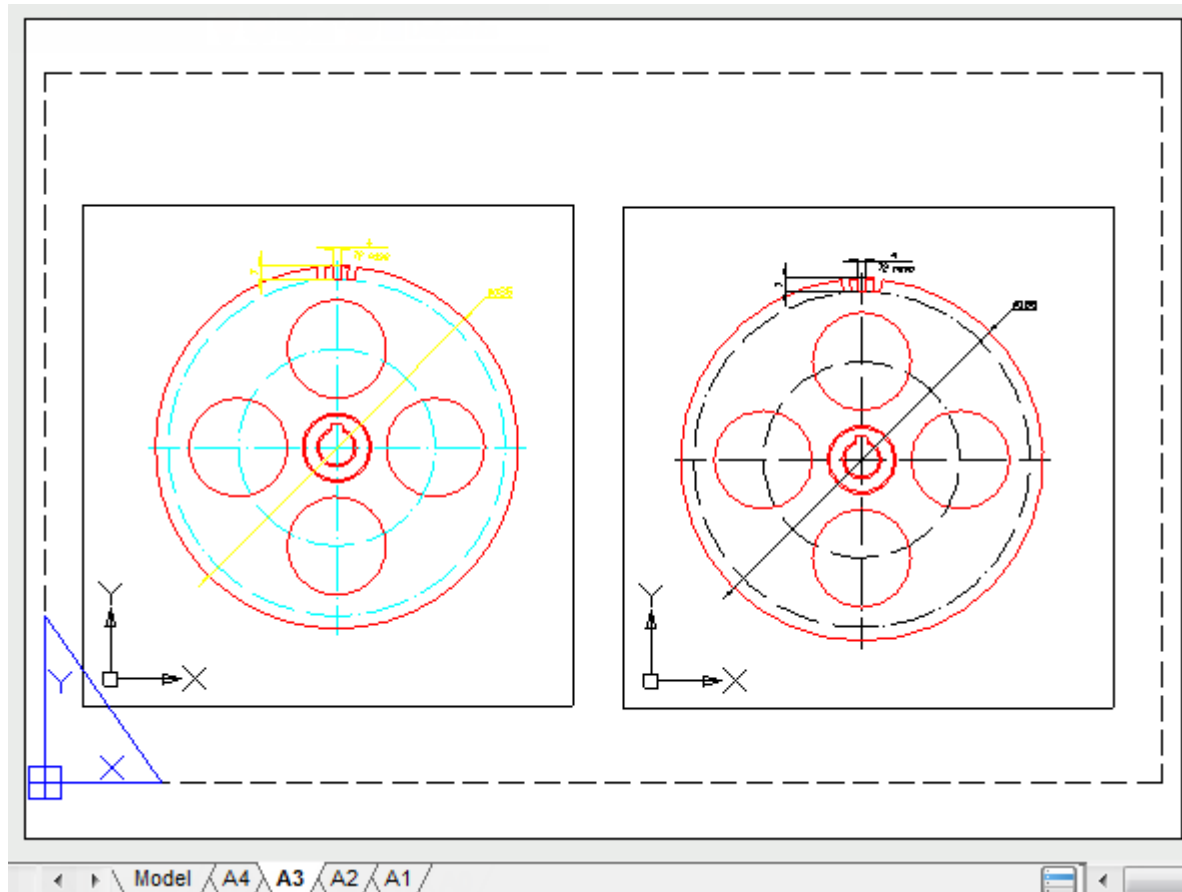

**To redefine properties of a current viewport of a layout:**

1. Double click this viewport to make it active.
2. Open the **Layers** dialog.
3. Select a layer from a list and change its parameters. You can redefine **Color, Linetype, Lineweight** and **Transparency**.

Parameters are changed only in the viewport of a layout. Other paper space viewports and the model space parameters are unchanged.

Layers with redefinitions of properties in viewports are highlighted in blue:

VP Color	VP Line Type	VP Line Weight	VP Transparen	VP Plot Style	Description
white	Continuous	By Default	0	Color_7	
blue	Continuous	By Default	0	Color_5	
red	Continuous	1.58 mm	0	Color_252	
252	GOST 2.303 5	By Default	0	Color_252	
red	Continuous	By Default	30	Color_1	
yellow	Continuous	1.58 mm	0	Color_7	
251	GOST 2.303 5	By Default	0	Color_251	
white	Continuous	By Default	0	Color_7	
green	Continuous	By Default	0	Color_3	
30	Continuous	By Default	0	Color_30	

**Removing redefinitions of properties of viewports layers**

**Remove Viewport Overrides for** command in the context menu cancels redefinitions of layers' properties in viewports

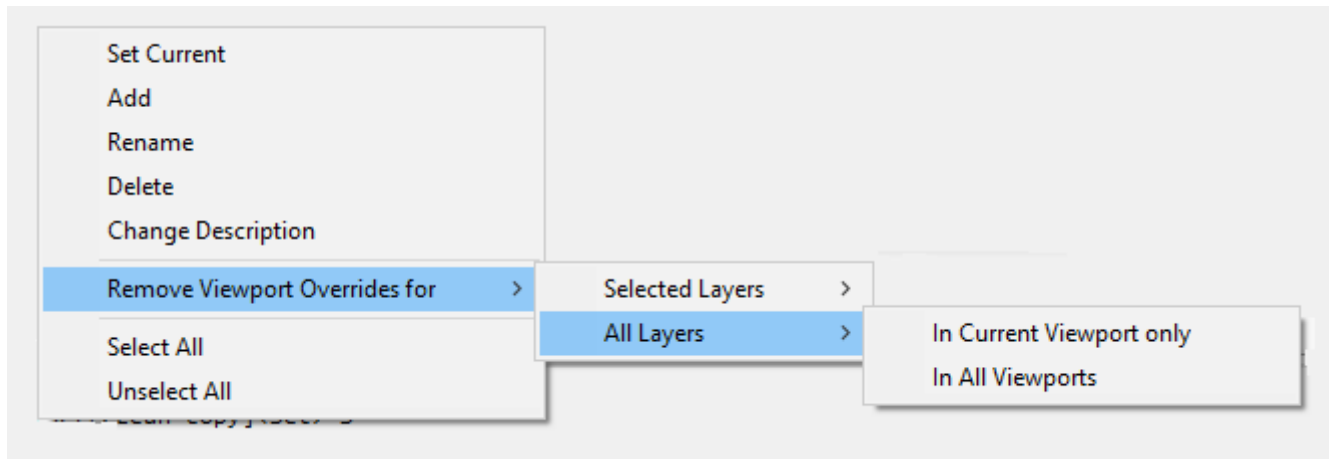

### Command options:

#### **Selected layers**

Cancels redefinitions of properties for layers selected in the dialog.

Cancellation can be made:

**In Current Viewport only**  
**In all Viewports.**

#### **All layers**

Cancels redefinitions of properties in all layers.

Cancellation can be made:

**In Current Viewport only**  
**In all Viewports.**

## Lock a Layer

If a layer is unlocked, you can create a new object on it. Objects created before locking are visible and they can be selected to view their properties, but they cannot be edited. You can snap to the object on a locked layer with an object snap. You can change the color, line type, weight type, make printable or unprintable on a locked layer.

Locked layers are marked with  icon.

You can lock or unlock several layers at once.



### To lock/unblock layer:

1. Select one or several layers in the list.
2. Click on the lock column of the selected layer.

### To select objects from locked layers:

In status bar click the  **Selection from locked layers** button.

## Controlling Layer Printability

The contour  icon means that objects on the layer can be printed. Objects on the layers with  icon will not be printed.

You can make several layers printable or unprintable at once.

### To make layers printable or unprintable:

1. Select one or several layers in the list.

- Click on the printability column of the selected layer.

## View Mode of Selected Layers

 Ribbon: **Home** – **Layers** >  **Layer walk**

 Menu: **Format** – **Layer tools** >  **Layer walk**

 Toolbar: **Properties** – 

 Command line: **LAYWALK**

There is a mode to view only the selected layers in nanoCAD. Visibility of all layers in this mode, except the selected, are switched off automatically; visibility is restored when you close this mode. This mode is a quick alternative to switching off the visibility of all layers to display the content of one layer; it is very convenient if there are a lot of layers in the drawing.



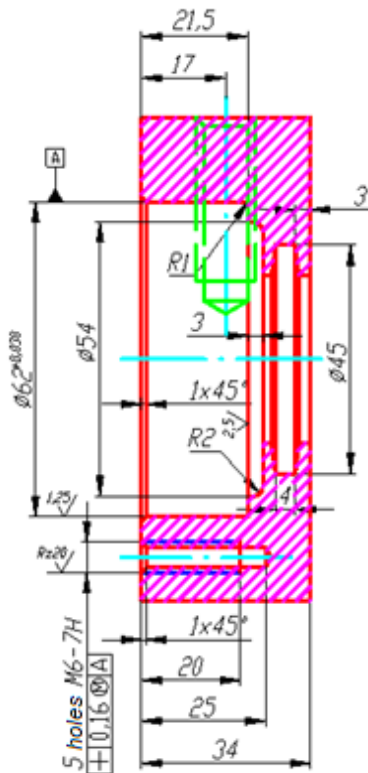

### All layer view mode

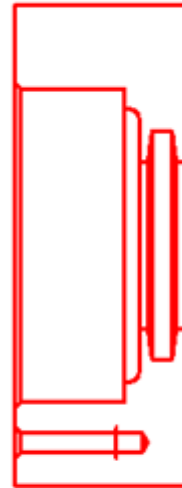

### Single layer view mode



### To switch on single layer or several layers view mode:

- Click a layer to view in the dialog.
- Select the  **Layer walk** button, visibility of all layers, except the one selected, are temporarily turned off. Near the selected layer in the  column the  icon is displayed. It means that this layer is visible.
- Click other layers to view. Near the selected layers in the  column the  icon is displayed. It means that this layers are visible. Visibility of all layers, except the selected, is temporarily switched off.

- Click on a visible layer (which marked with the  icon) turns off its visibility.

With the **Layers** dialog box opened you can zoom and pan the drawing using the corresponding commands.

To restore visibility of all the layers, switch off the  **Layer walk** button or close the **Layers** dialog box.

This mode is a quick alternative to switching off the visibility of all layers to edit the content of one layer. After selecting the mode, select any command and the **Layers** dialog box closes and the selected layer will be displayed. To restore the visibility of all layers after editing, open the **Layers** dialog box and the visibility of all layers is restored automatically.





## Creating and Editing Group of Layers

The **Layers** dialog box allows merging of layers into groups. Grouping of layers is recommended when a document contains a lot of layers and you often need to change the settings of several layers; for example, to quickly block/unblock them or to control their printability.

One layer can belong to different groups.

### Creation of a New Group of Layers

*To create a group of layers for the entire document:*

- Select **All** in the categories tree.
- Select the button  **Add group** and the button  **Show all layers (for group)**. To the left of the current layer icon column, the column  for selecting layers for the groups is shown.
- Enter a group name (the default name is *Group...N*, where *N* – is the number of the created group).
- Select layers to make a group.
- Select the  **Edit filter** button to complete creating the group.

To add a subgroup of layers, select the existing group, in the context menu select the command **Add > Group**.

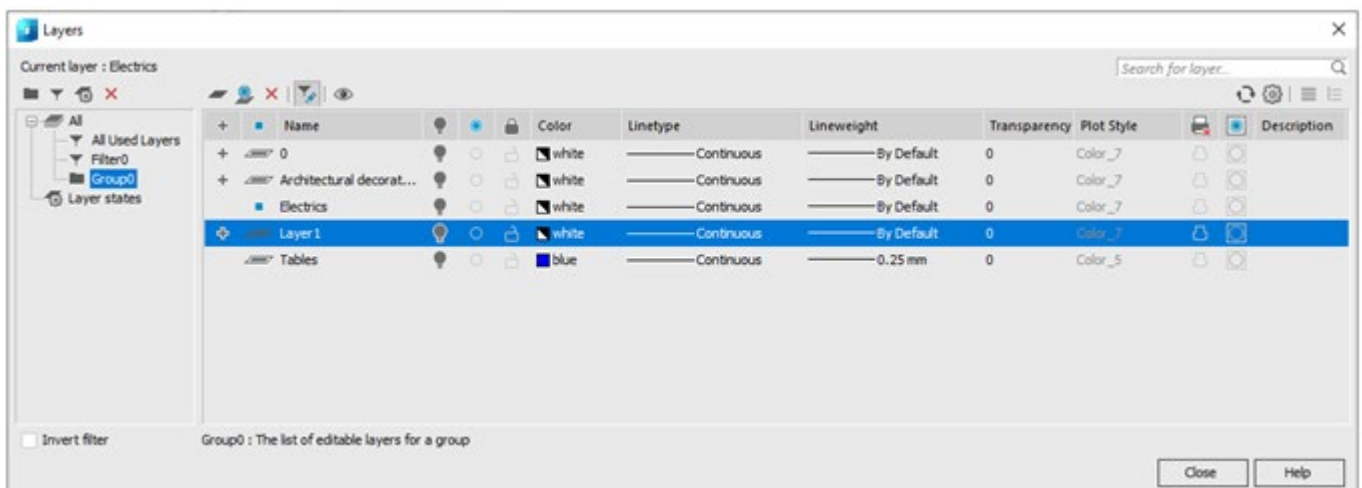



When adding new layers to a subgroup they are automatically added to all parent groups.

You cannot create a subgroup of layers for a filter.



## Editing a Group of Layers

### To add or exclude layers from a group:

1. Select the group in the categories tree.
2. Select the **Edit filter**  button.
3. In the  column for selecting layers for groups, select the layers to form the group. Layers of the parent group are always selected.

The **Layers** ribbon group and the **Layers2** toolbar contain a drop-down box to select states to restore from the list of existing ones.

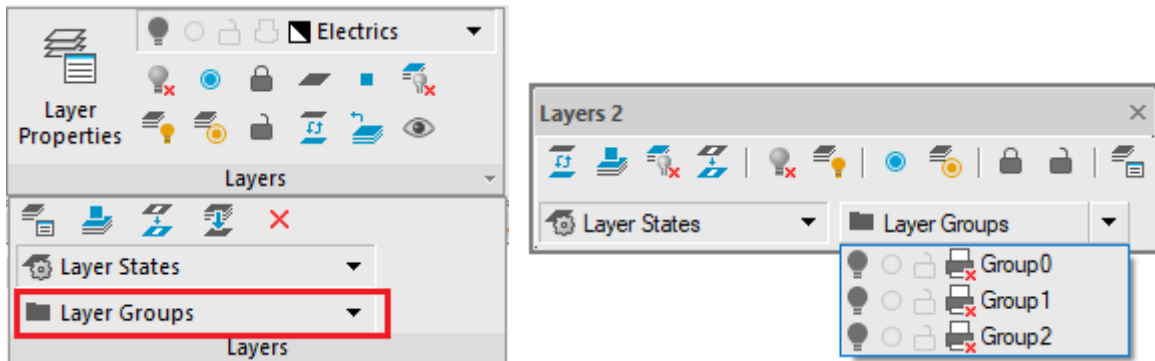



## Creating and Editing Filters

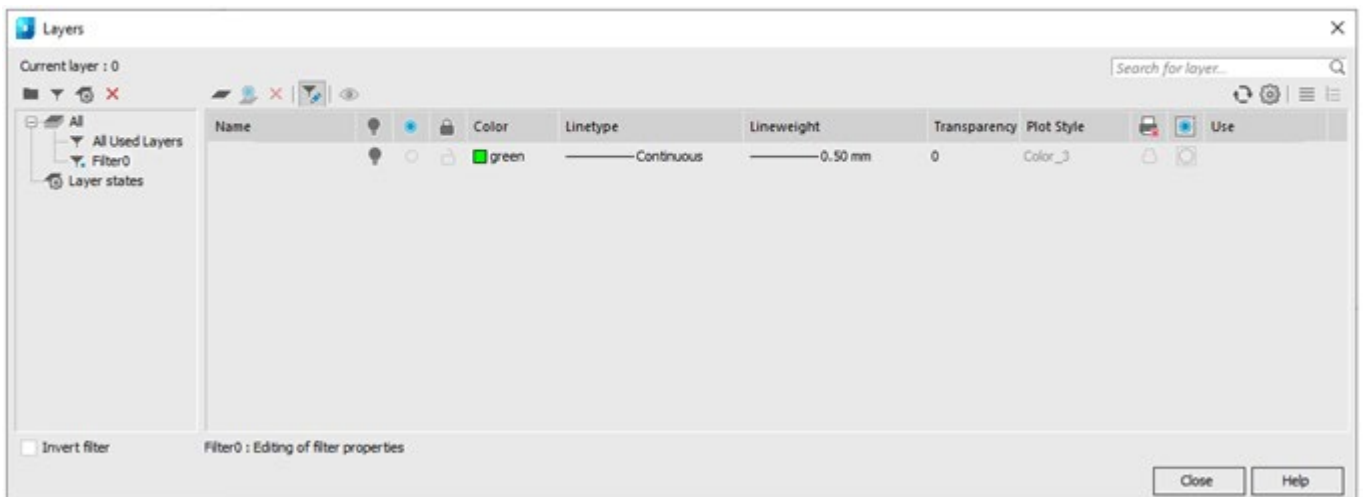

A filter forms a list of layers that satisfy certain selection criteria. Selection in the filter is performed by one or several parameters of the layers; for example, selection of layers having a green color and line weight 0.50 which can be printed.



## Creation of a New Filter

### To create a layers filter for the whole document:

1. Select **All** in the categories tree.
2. Select the  **Add filter** button. The  **Edit property** button is automatically selected.
3. Enter a filter name (a filter has a default name *FilterN*, where *N* is the number of the created filter).

4. In the **Editing of properties of the filter** window, specify the selection criteria for the layers in the filter.
5. Criteria, specified in one row are linked with the logical "AND".
6. Criteria, specified in different rows are linked with the logical "OR".
7. The  **Add** and  **Delete** buttons are used to add or delete rows of selection criteria.
8. Select the  **Edit property** button to finish filter creation.

A layer's name is often used as a selection criterion. Names can be specified as templates.



It is possible to use the following symbols in the template of a layer's name:

Symbol in a template		Corresponding symbols in a layer's name
*	<b>Asterisk</b>	Any sequence of symbols.
?	<b>Question mark</b>	Any symbol.
#	<b>Hash</b>	Any figure.
@	<b>At sign</b>	Any letter.
.	<b>Point</b>	Any symbol except a letter or figure.
~	<b>Tilde</b>	Any sequence of symbols except the sequence after the tilde.
[ ]	<b>Square brackets</b>	Any symbol except the symbols in brackets.
[~]	<b>Tilde in square brackets</b>	Any symbol except the symbols in brackets.
[-]	<b>Dash in square brackets</b>	Any symbol from the range starting with the symbol to the left of the dash and ending with the symbol to the right of the dash.
`	<b>Backtick character</b>	Backtick character shows that the following symbol is an ordinary symbol and not special.

If you select a group instead of the **All** element, a filter is created for the group.













## Editing Layers Filter

### To add to or exclude layers from a filter:

1. Select the **All** in the categories tree (to create a filter for all layers in the document) or a group (to create a filter only for the group).
2. Select the  **Edit property** button.
3. In the **Editing of properties of the filter** window specify the selection criteria for layers in the filter.
4. Criteria, specified in one row are linked with the logical "AND".
5. Criteria, specified in different rows are linked with the logical "OR".
6. The  **Add** and  **Delete** buttons are used to add or delete rows of selection criteria.

7. Select the  **Edit property** button to finish filter creation.

Criteria symbols to select layers for a filter:

	Visible layer.
	Invisible layer.
	Frozen layer.
	Unfrozen layer.
	Locked layer.
	Unlocked layer.
	Layer available for printing.
	Layer unavailable for printing.
	Layer becomes unfrozen in new viewports.
	Layer becomes frozen in new viewports.
	Used layer.
	Unused layer.

### ***“All Used Layers” Filter***

All nanoCAD documents contain a preset layers filter **All used layers**:

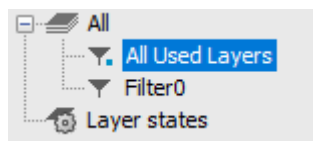

The filter shows all layers used in the current document. A filter does not show unused layers in a document. You cannot delete this filter.

### ***All Layers without xrefs Filter***

The preset layer filter **All Layers without xrefs** becomes available if a document contains layers with external references:

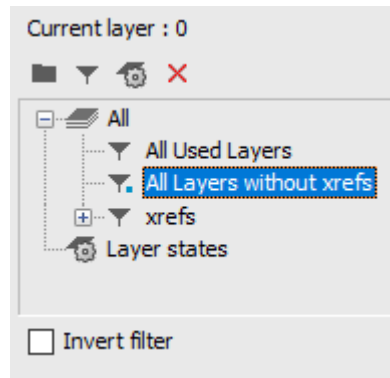

The filter selects all layers of the current document without external references. The filter does not display layers with external references. The filter cannot be deleted.

## “Invert Layers” Checkbox

The **Invert filter** parameter below the categories tree can be used to display all the layers, which are not in the group, filter, external reference or configuration.

For example, to display all unused layers in a document, select the **All used layers** and select the **Invert filter**.

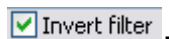

When you deselect the **Invert filter** the list of layers recovers.

It is often needed to display layers of a particular category.

**You can use the Invert filter for this:**

1. Select a group or a filter in the categories tree.
2. Select the **Invert filter**.
3. Select all layers in the list and make them invisible.

## Configurations of Layers

Configurations of layers are backup copies of layers' parameters.

Configurations are placed in the separate **Configurations** folder in the categories tree.

A configuration is created for all layers in the document.

To create a configuration, select the  **Add configuration** button. A new configuration has a default name – *Configuration N*, where *N* is the number of created configurations.

A created configuration can be edited, e.g. to change the parameters of its layers.

Configurations can be restored, renamed and deleted.

A recovery of a configuration places a copy of the parameters of the layer with the same name into the document; it means recovering the parameters of the layers and returning them to the moment the configuration was created.

### Restore state

To recover a state, select **Restore** from the context menu of the state:

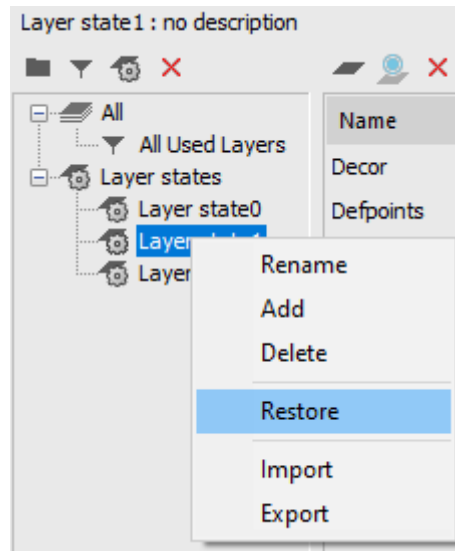

The properties of layers to be restored are selected in the **Restore layer properties** dialog box:

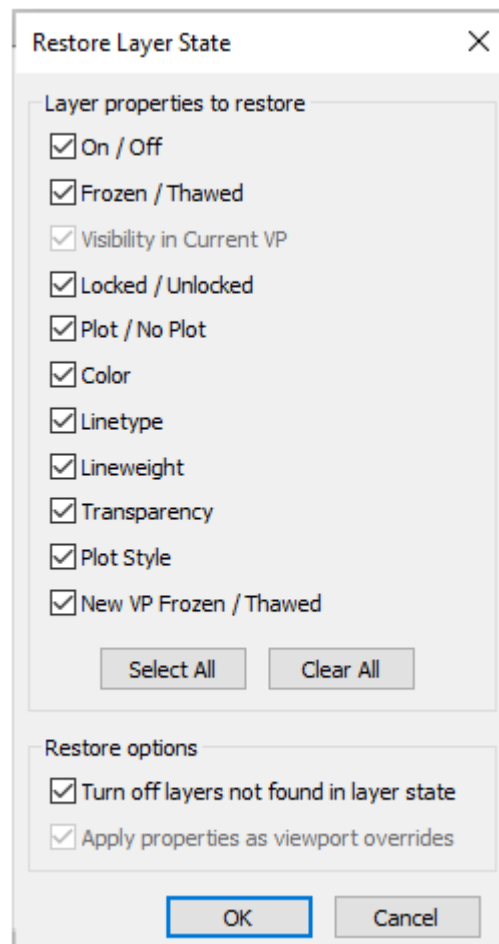

Layers added in a drawing after creating a state of layers and not saved in it can be turned off when restoring a state by checking the **Turn off layers not found in layer state** box.

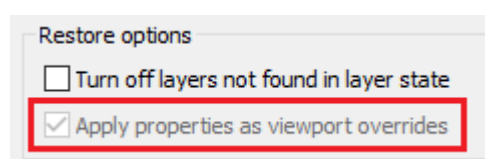

When restoring a layer state saved from the layout viewport, you can choose whether to use settings of such state as global properties of a drawing layers or as overrides for *this viewport*.

The option **Apply properties as viewport overrides** is intended for this. Adding layers in a state

### **Adding layers in the configuration**

Layers that appeared in a document after creating a state, can be added in the state.

1. Select a state you need to add layers to.
2. Click the  **Add** button or select **Add** in the context menu of the list of layers
3. Select layers to be added in the **Select Layers to Add to Layer State** dialog box, click **OK**.

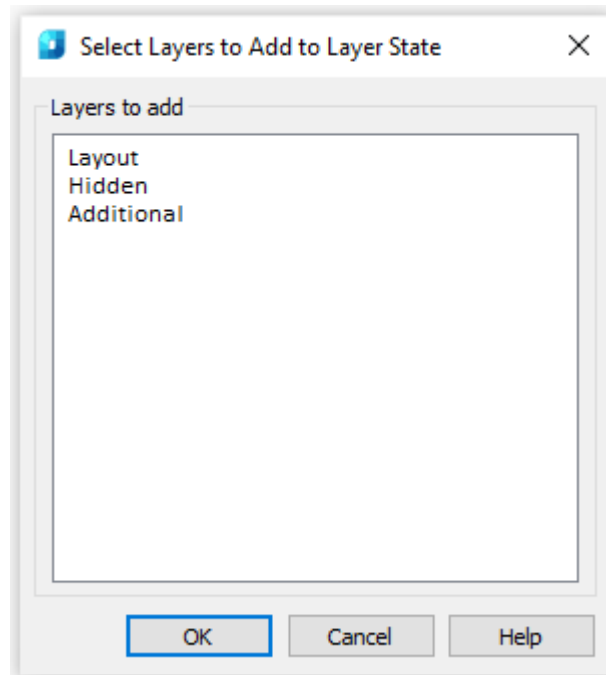

## **Layer State Manager**

Saves, restores and manages named states of layers.

You can call **Layers state** dialog with the following commands:



Ribbon: **Home – Layers** > 



Menu: **Format –**  **Layers state...**



Command line: **LAYERSTATE**



Toolbar: **Layers 2 –** 

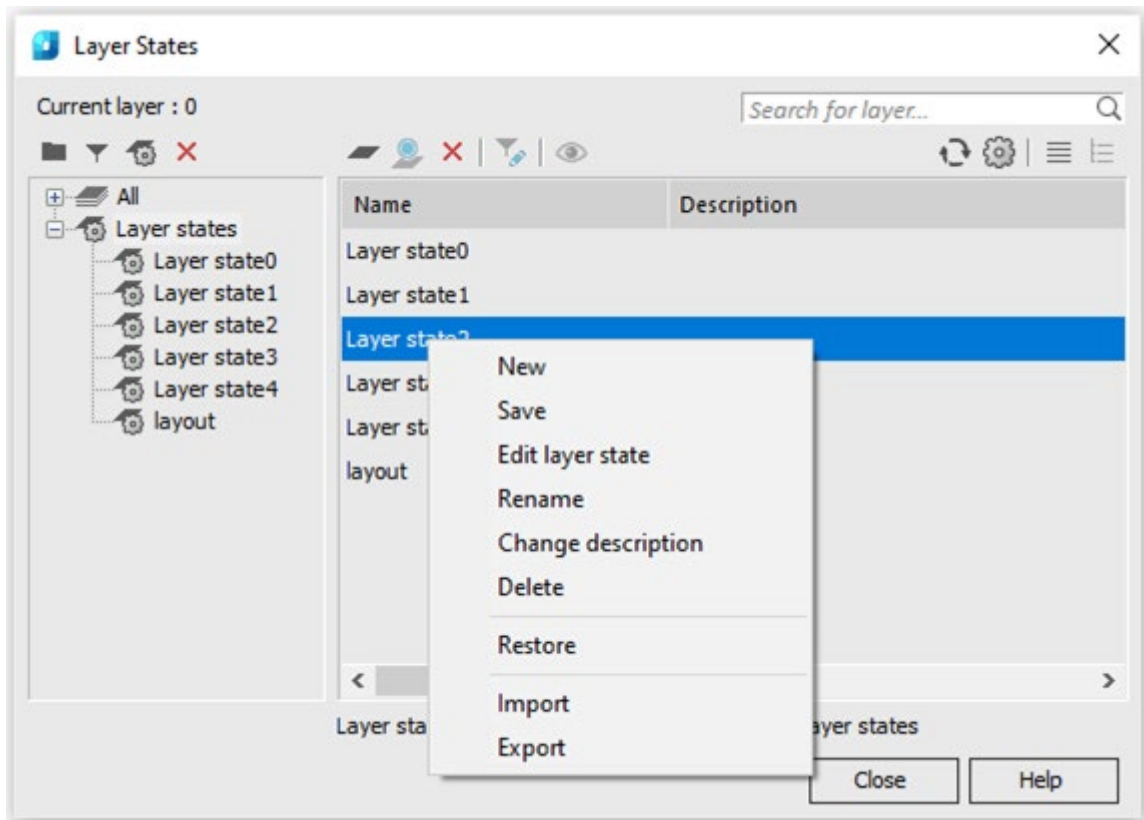

A state can be exported to LAS file and imported from LAS file or \*.dwg file (**Import** and **Export** commands of the context menu). When importing, you will be prompted to restore the layer settings from the imported states.

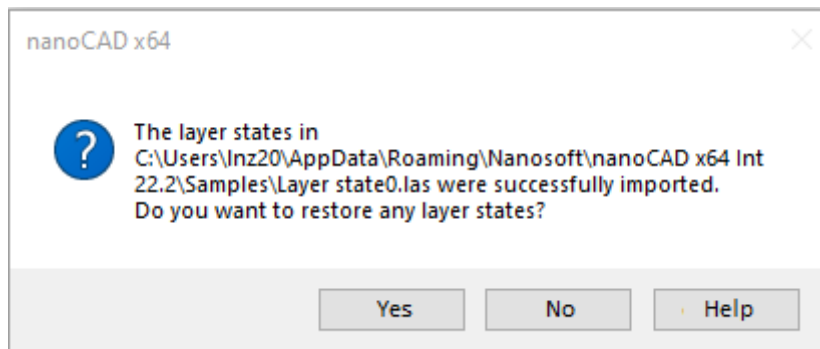

If you agree, the standard process of restoring the state will start, and the **Restore Layer State** dialog will appear, in which you should select the properties to be restored.

The **Layers** ribbon group and **Layers 2** toolbar contain a window to select states to restore from the list of existing ones.

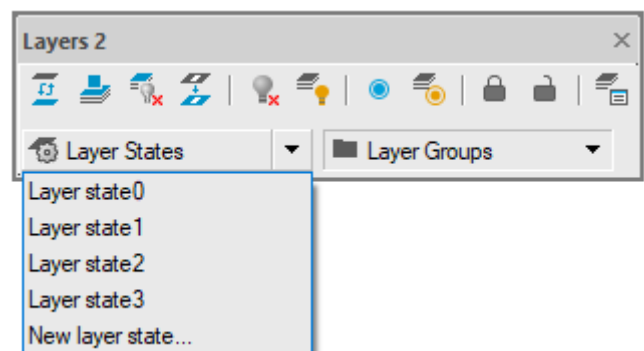
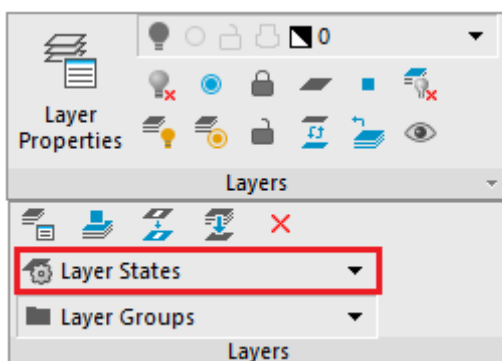

The command of the **New layer state** list allows for quick saving of layers settings in a new state without opening the **Layers** dialog box.

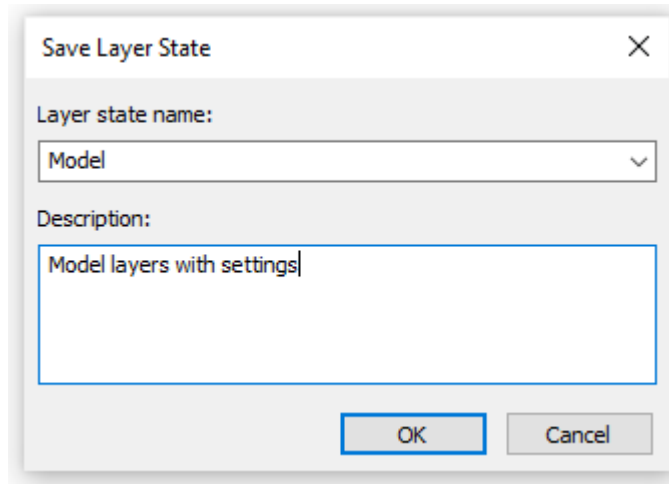

The **Save Layer State** list that opens allows for the possibility to save changes in already existing states:

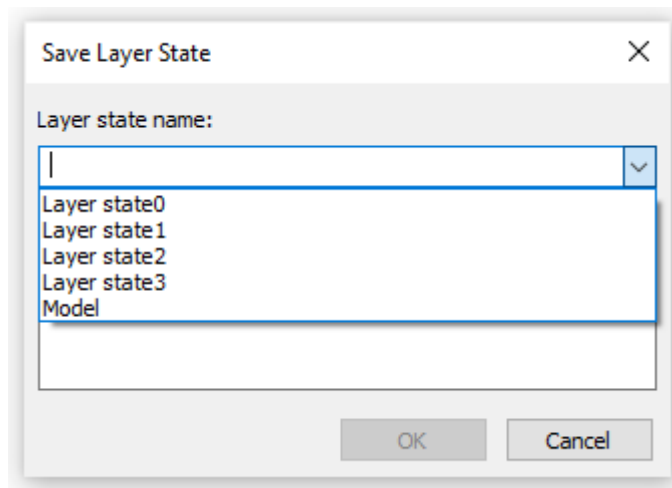

## Layers Functional Bar



Ribbon: **Home** – **Layers** >  **Layer Manager**



Ribbon: **Manage** – **Palettes** >  **Layer Manager**



Menu: **View** – **Toolbars** > **Functional** >  **Layer Manager...**



Toolbar: **Functional** –  **Layer Manager...**



Command line: **LAYERSQUICK**

The **Layers** functional bar is designed to manage layers and their properties:



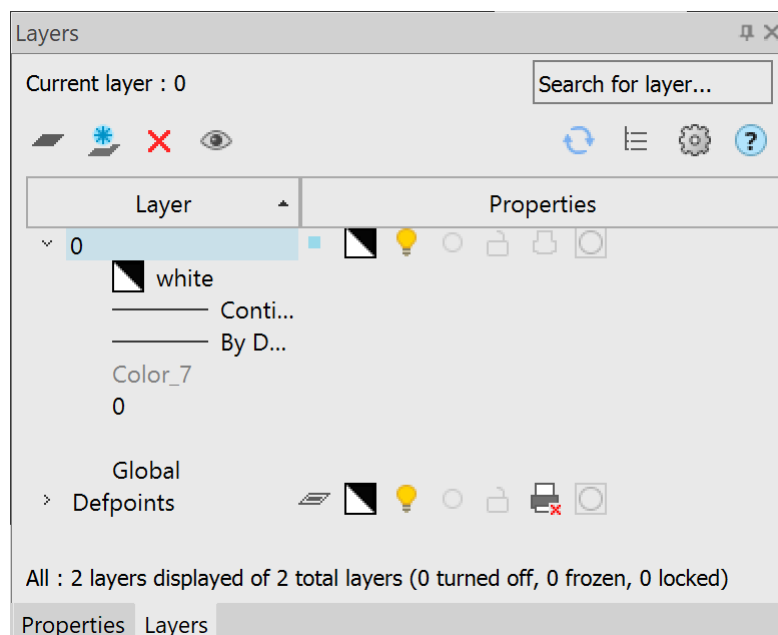
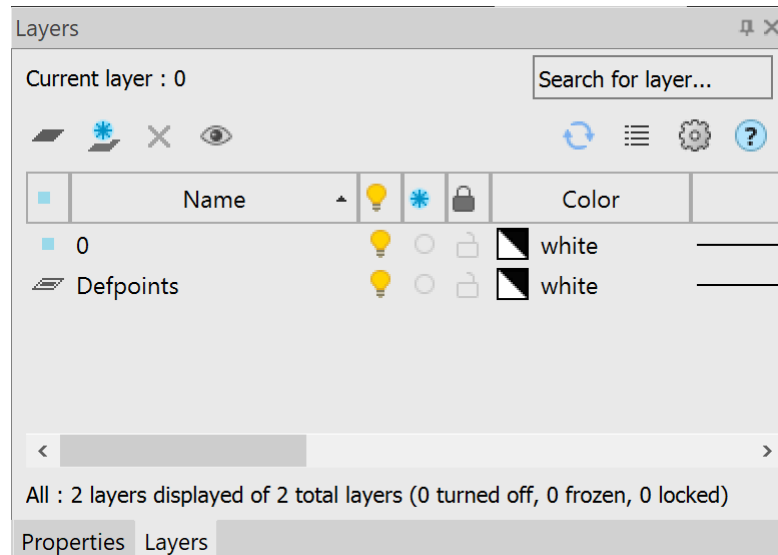

At the top of the toolbar, immediately under the title, the name of the current layer and the Search for layer field are displayed (the search is carried out by the layer name):

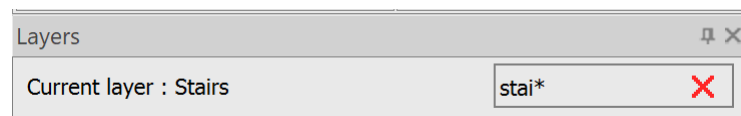









The field's **Clear** button resets the search results.

The bottom part of the toolbar contains information about the displayed layers, the total number of layers, the number of turned off, frozen and locked layers:

All : 11 layers displayed of 11 total layers (0 turned off, 3 frozen, 1 locked)

Below the name of the current layer there are buttons:

-  **Add** Adds a new layer.
-  Add Layer VP Frozen in All Viewports Adds a layer frozen in all viewports.
-  **Delete** Deletes the selected layer.







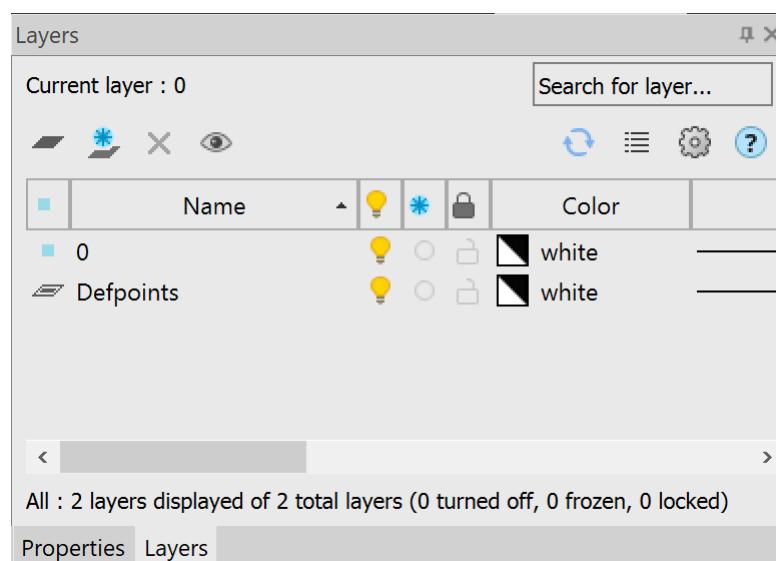

-  **Layer walk**                      Enables view mode for only selected layers.
  
-  Refresh                                      Regeneration.
  
-  Tree or  table view                      Changes the presentation format of layers and their properties in the bar.
  
-  **Layer Settings**                      Manages the display options in the Layers bar and properties of layers included in external references.



The list of layers can be presented in a tree or table view. By default, the display mode is set to a tree view.

## Table view of the list of layers



The table view displays layer properties as a table with columns:

-  **Status**                                      Indicator of the content of objects on the layer.
  
-                                       The current layer.
  
-                                       The layer contains objects.
  
-                                       The layer contains no objects.
  
-                                       Xref layers (a layer contains/does not contain objects).
  
-                                       The layer has properties override enabled in the viewport (layer is current, layer contains/does not contain objects).
  
- Name**                                      Displays the layer name.
  
-  **On**                                      Displays the layer's visibility icon.
  
-  **Freeze**                                      Displays the layer's freeze icon.
  
-  **Lock**                                      Displays the layer's lock icon.
  
- Color**                                      Displays the layer's color.
  
- Linetype**                                      Displays the layer's linetype.
  
- Lineweight**                                      Displays the layer's lineweight.

<b>Transparency</b>	Displays layer's transparency.
<b>Plot Style</b>	Displays the layer's plot style.
 <b>Plot</b>	Displays the plot resolution for the layer.
 <b>New VP Freeze</b>	Displays the icon of the layer freeze in a new viewport.
<b>Description</b>	Brief information about the layer.
<b>Covering</b>	Displays the layer covering.

When working in paper space and with a current paper viewport, columns with information about the parameters of layers in the current viewport are added to the layer list table:

 <b>VP Freeze</b>	Displays the icon of the layer freeze in the current viewport.
<b>VP Color</b>	Displays the layer's color in the current viewport.
<b>VP Line Type</b>	Displays the layer's linetype in the current viewport.
<b>VP Line Weight</b>	Displays the layer's line weight in the current viewport.
<b>VP Transparency</b>	Displays the layer's transparency in the current viewport.
<b>VP Plot Style</b>	Displays the layer's plot style in the current viewport.

Double-clicking the left mouse button on the column title separator automatically changes the width of columns:

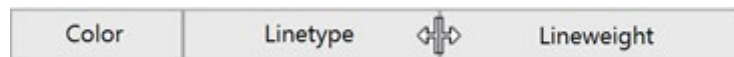

## Tree view of the list of layers

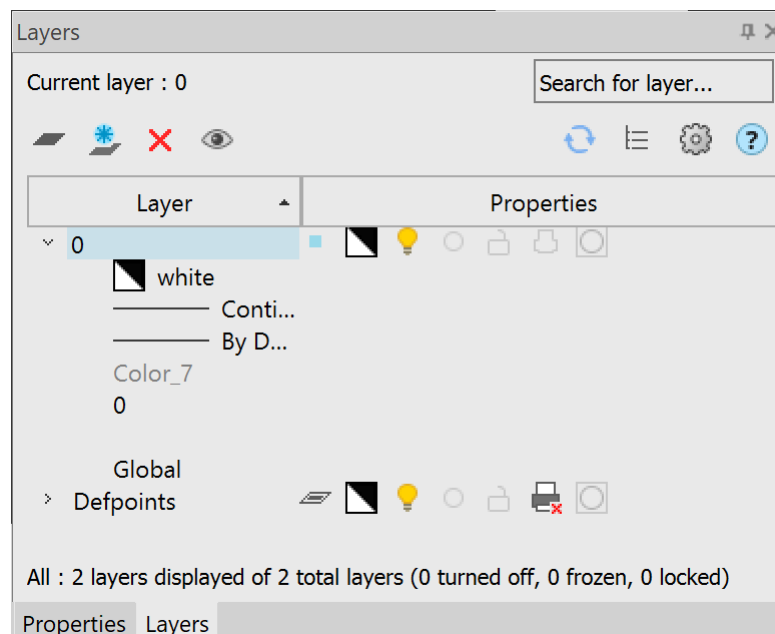

In the tree view, the left column displays the names of the layers, and the right one displays the properties.

The Properties column displays the following options: Status, Color (VP Color), Layer Visibility, Frozen, Locked, Plot, New VP Freeze, VP Freeze.

The remaining parameters are expanded as a list under the layer name when you left-click on the arrow to the left of the layer name:

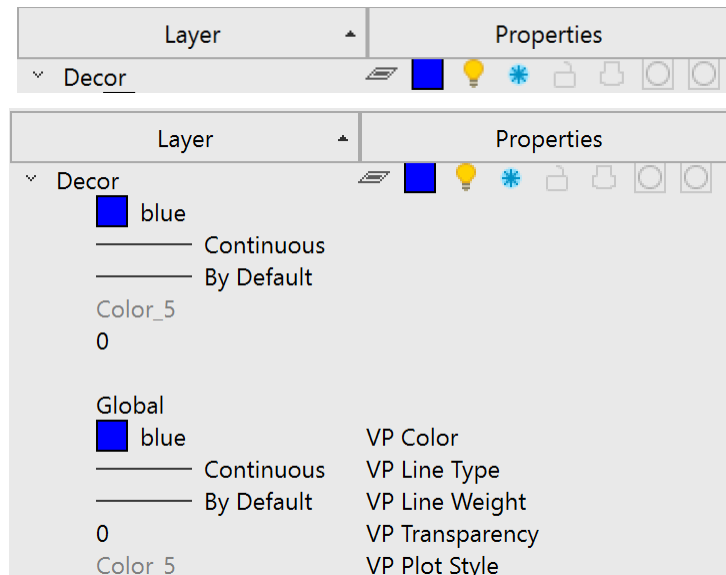

## Search for Layers by Name

To quickly search for layers by name, use the **Search for layer** field in the upper right part of the dialog.

### To search for layers by name:

4. Enter the layer's name or part of the name in the field to search.

As you type, only those elements whose names contain the entered expression remain in the list of layers.

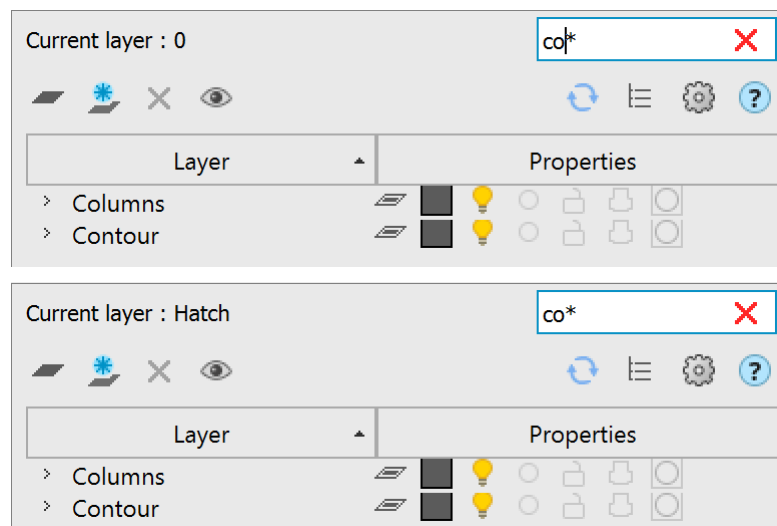

The following special characters can be used in the field:

	Character	Corresponding characters in a layer's name
*	<b>Asterisk</b>	Any sequence of characters.
?	<b>Question mark</b>	Any single character.
#	<b>Hash</b>	Any single digit.
@	<b>At sign</b>	Any single letter.

.	<b>Dot</b>	Any single character other than a letter or digit.
~	<b>Tilde</b>	Any sequence of characters except the one after the tilde.
[ ]	<b>Square brackets</b>	Any single character of those located inside brackets.
[~]	<b>Tilde in square brackets</b>	Any single character except those inside brackets.
[-]	<b>Dash in square brackets</b>	Any single character from the range starting with the character to the left of the dash and ending with the character to the right of the dash.
`	<b>Backquote</b>	A backquote indicates that the character that follows it is a regular character and not a special character.



## Creating a New Layer

A newly created layer has properties set by default (the same as layer 0). If you select a layer before clicking the button, the properties of that layer will be used by default for the new layer. After creating a new layer, its properties can be modified.

### To create a new layer:

5. Click the  **Add** button.

### To create a new layer frozen in all viewports:

6. Click the  **Add Layer VP Frozen in All Viewports** button. A layer frozen in all viewports will have the  icon next to its name in the **VP Freeze** column.

A new layer is added to the list of layers with the default name *LayerN*, where *N* is the sequential number of the created layer, starting from 1. The name assigned to the created layer by default can be changed. The name should contain at least one character. Layer names should not be duplicated. Invalid characters for a layer name: < > / \ " " : ; ? \* | , = ` tab character.

A new layer can be also created by the context menu command **Add** or **Add Layer VP Frozen in All Viewports**.

## Deleting a Layer

Layers that are not used in the document can be deleted. The current layer, even if it is not used in the document, cannot be deleted. You can remove several layers at once.

### To delete a layer:

7. Select one or more layers in the list.

Click the  **Delete** dialog button

A layer can also be deleted using the **Delete** context menu command.

When deleting used layers that contain objects, the **Delete** command opens the **Delete Used Layers** dialog box to select deletion options:

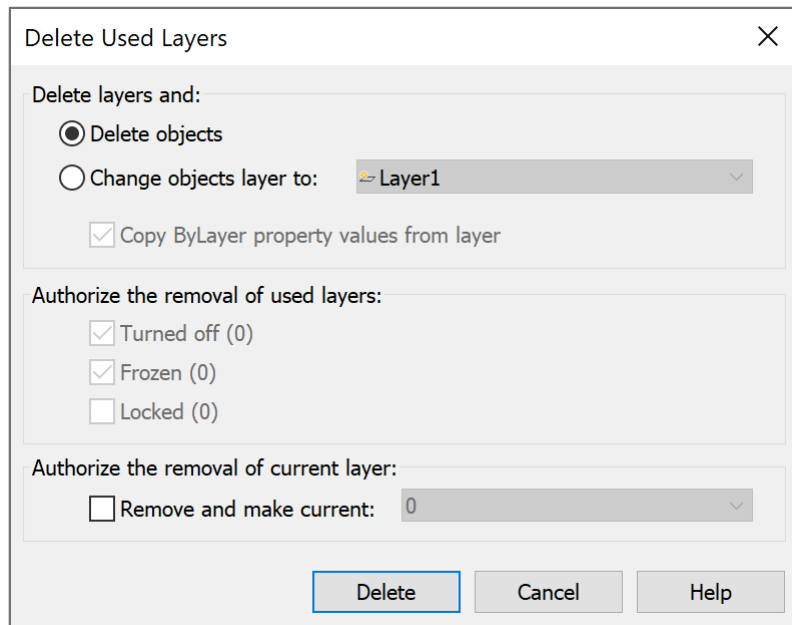

**Delete layers and:**

Selects an action with objects of the layer to be deleted.

**Delete objects**

Deletes the selected layer with all objects on it.

**Change objects layer to**

Moves objects of the layer being deleted. You can move objects to an automatically created new layer *LayerN* or select an existing layer from the list.

**Copy ByLayer property values from layer**

Saves the **By Layer** property values for objects being moved.

**Authorize the removal of used layers:**

Sets permission to delete layers with certain properties: **Turned off, Frozen, Locked**. These options are only available if the layers to be deleted contain these properties. The number of selected layers with this property is displayed in brackets.

**Authorize the removal of current layer**

Sets permission to delete the current layer.

**Remove and make current**

Selects the current layer from the list when deleting a previously installed one.

9. After setting the parameters, click the **Delete** dialog button.

If there are layers in the selection for deletion that cannot be deleted, information about them (layer name and reason) is displayed in the **Delete Layers** dialog:

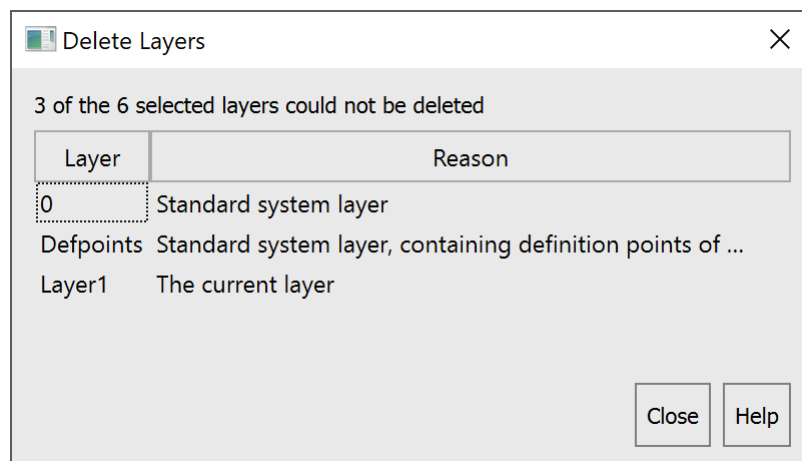









**NOTE** You can delete the Defpoints standard system layer using the **LAYDEL** command.

## View mode for selected layers (layer walk)

In the selected layers view mode, the visibility of all layers except the selected ones is turned off, and when exiting the mode, it is restored to its previous position. This mode is convenient to use when there are a large number of layers in the drawing.

### To view one or more selected layers:

10. Select one or more layers in the list with the left mouse button.
11. Enable the  **Layer Walk** button, in this case the visibility of all layers except the selected ones will be temporarily disabled. The  icon is displayed next to the selected layers in the  column, indicating that these layers are visible in the drawing.
12. You can add other layers for viewing by left-clicking on the  icon in the  column (the icon changes to ).
13. Left-clicking on the  icon turns off the layer visibility (the icon changes to .

### To exit the view mode for selected layers:

14. Disable the  **Layer Walk** button.

The visibility of all turned off layers will be restored.

## Layer Settings

To manage the display parameters of layers and the layer properties included in external references, use the Layer Settings dialog, which is opened by clicking the  button.

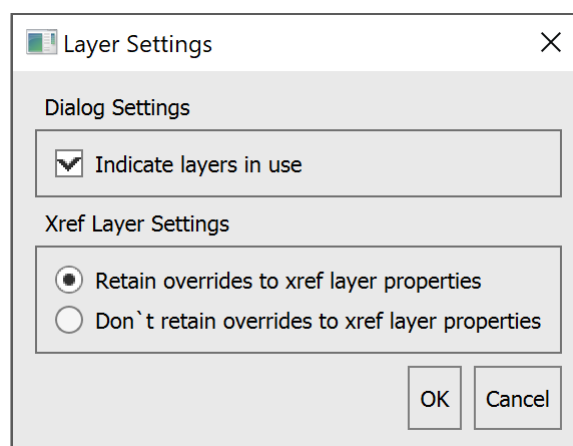







### Dialog options:

#### Indicate layers in use

Whether or not to mark unused layers in the list of layers.

The status of the used layers does not depend on the option.

The status of an unused layer when the option is enabled will look like this: ,  or ; with the option disabled – ,  or .

### *Xref Layer Settings:*

#### **Retain/Don't retain overrides to xref layer properties**

Whether or not changes to the parameters of layers included in external references are retained.

## **Sorting Layers**

The list of layers can be sorted by any parameter. To sort the list of layers by any parameter, just left-click on its column header.

The sorting direction is indicated by an arrow in the header of the sorted parameter.



## **Editing Layer Parameters**

### **Selecting layers from the list**

A layer is selected by clicking on it with the left mouse button.

You can edit the parameters of several selected layers at once.

Holding down the **SHIFT** key selects all layers located between the first and last mouse click.

By holding down the **CTRL** key, you can add any layer from the list to the existing selection of layers by clicking the mouse.

All layers in the list are selected using the **Select All** context menu command. The **Unselect All** command deselects all selected layers in the list.

### **Renaming a Layer**

The following layers cannot be renamed: Layer 0 and layers that depend on xrefs.

#### **To rename a layer:**

15. Select a layer in the list.
16. Left-click on the layer name or press the **F2** key.
17. Enter a new layer name.
18. Press **ENTER**.

A layer can also be renamed using the **Rename** context menu command.

### **Setting a Layer Current**

#### **To set a layer current:**

19. Left-click in the icon display column opposite the name of the selected layer. The  icon will be located opposite the selected layer, which indicates that this layer is the current one.

The current layer can also be selected using the **Set Current** context menu command.



## Assigning Properties to a Layer

A layer can be assigned such properties as Color, Linetype, Lineweight, Transparency, Description and Covering, which will be inherited by all objects on that layer if these object properties are set to **By Layer**.

**To assign Color, Linetype, Lineweight, Transparency, Description and Covering for one layer in a tree view of the list of layers:**

20. Open the layer parameters by left-clicking on the arrow to the left of the layer name.
21. Left-click on the desired parameter.
22. Select the required parameter value from the drop-down list. For the Explanation property, in the Place for description... field, enter the explanatory text.



**Color, Linetype, Lineweight, Transparency, Description and Covering can be set for several layers at once:**

23. Change the presentation of layers to table view format using the  button.
24. Select one or more layers in the list.
25. Left-click in the column of the desired property of one of the selected layers.
26. Select the required parameter value from the drop-down list. For the Explanation column, enter the explanatory text in the Place for description... field.

The description can also be changed using the **Change Description** context menu command.

## Managing a Layer Visibility

Objects located on turned off layers are not displayed on the screen and are not printed, but take part in the drawing regeneration. However, when turning layers on/off, the drawing does not regenerate. In this regard, it is recommended to turn layers on/off in cases where this needs to be done frequently and when layers are turned off for a short time. Otherwise, it is better to freeze the layers.



Visible layers are indicated by the  icon. The  icon indicates that the visibility of this layer is turned off.

You can turn visibility on and off for several layers at once.

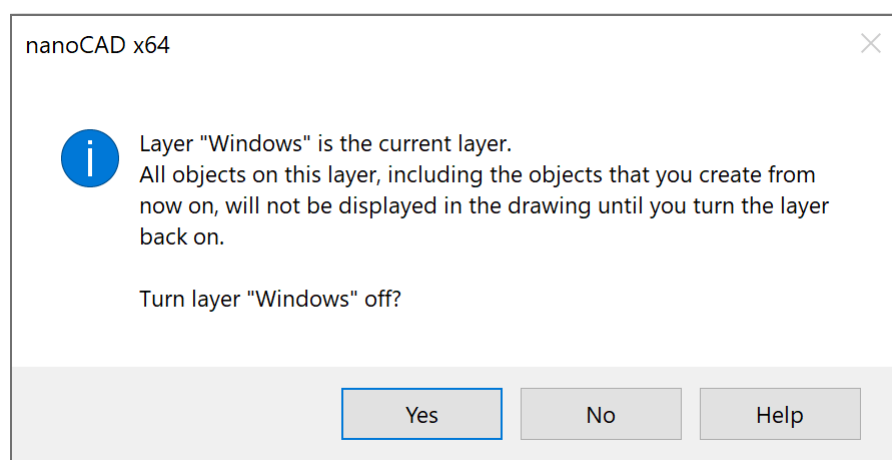
When you turn off the visibility of the current layer, a warning window appears.



**To turn on/off a layer visibility:**

27. Select one or more layers in the list.
28. Left-click in the column that displays the  () icon next to the name of one of the selected layers.

**NOTE** You can manage the visibility of drawing objects not only by switching the visibility of the layer they lie on, but also directly using the commands for hiding and isolating objects.



## Freezing a Layer

Objects located on frozen layers are not displayed on the screen, are not printed, and do not participate in drawing regeneration. Freezing unnecessary layers in large drawings can accelerate displaying and regenerating operations. However, the operation of thawing one or more layers leads to the drawing regeneration, which takes quite a long time. In this regard, layers should be frozen in cases where it is rarely necessary and when layers are frozen for a long time. Otherwise, it is better to turn off the visibility of layers.

Frozen layers are indicated by the  icon, and thawed ones by .

You can freeze and thaw several layers at once. You cannot freeze the current (  ) layer.

### To freeze/thaw a layer:

29. Select one or more layers in the list.
30. Left-click in the column that displays the  (  ) icon next to the name of one of the selected layers.

## Freezing Layers in Layout Viewports

Layers can be frozen in individual layout viewports. This way, you can get different displays of the same objects in different viewports without creating additional (duplicate) geometry, for example, by creating two viewports for the same object and freezing the layer with design elements in the second viewport.

Layers frozen in the current viewport are indicated by the  icon.

The section of Managing Frozen Layers in Individual Viewports describes the **VPLAYER** command in detail.

### To freeze a layer in the current viewport:

31. Activate the viewport by double-clicking on it with the left mouse button.
32. In the list of layers, select all layers to be frozen in the current viewport.
33. Freeze the selected layers by clicking on the  icon for any selected layer.

The layer will be frozen only in this viewport and visible in all others. When printing a layout, the frozen layer will also not be plotted in just that one viewport.

### To freeze a layer in all VPs:

1. In the list of layers, select all layers that should be frozen in all viewports.
2. Right-click on the selected layers to open the context menu and select the **VP Freeze Layer > In All Viewports** command.

The layers will be frozen and invisible in all viewports.

### To freeze a layer on all VPs except the current one:

1. Activate the viewport by double-clicking on it with the left mouse button.
2. In the list of layers, select all layers that should be frozen in all viewports except the current one.
3. Right-click on the selected layers to open the context menu and select the **VP Freeze Layer > In All Viewports Except Current** command.

The layers will be frozen and invisible in all viewports except the current one.

You can also use the **LAYVPI** command to freeze a layer in all layout viewports except the current one.

**To thaw a layer in all VPs:**

1. In the list of layers, select all layers to be thawed in all viewports.
2. Right-click on the selected layers to open the context menu and select the **VP Thaw Layer in All Viewports** command.

The layers will be thawed and visible in all viewports of all layouts.

## Overriding Layer Properties in Viewports

Layer property override is a way to display objects in different layout viewports with different property values (color, linetype and lineweight, transparency) without changing the properties that are assigned with ByLayer or ByBlock values.

**To override properties for the current layout viewport in a tree view of the list of layers:**

3. Activate the viewport by double-clicking on it with the left mouse button.
4. Open the layer parameters by left-clicking on the arrow to the left of the layer name.
5. Left-click on the desired property: **VP Color**, **VP Linetype**, **VP Lineweight** or **VP Transparency**.
6. Select a value from the drop-down list.

**To override properties for the current layout viewport for multiple layers:**

7. Change the presentation of layers to table format using the  button.
8. Select one or more layers in the list.
9. Left-click in the property column (**VP Color**, **VP Linetype**, **VP Lineweight** or **VP Transparency**) of one of the selected layers.
10. Select a value from the drop-down list.

The parameters will be changed only in that layout viewport. In other viewports and in **Mjodel** space, these parameters will remain unchanged.

Layers that have property overrides in viewports are highlighted in blue and the status indicator for such layers has changed:

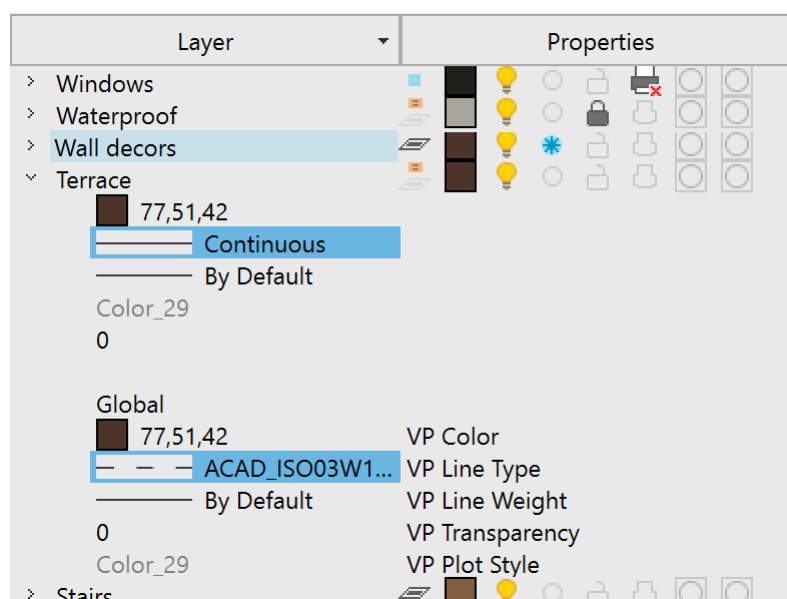

**Removing Viewport Layer Property Overrides**

To cancel overrides of layer properties in viewports, use the **Remove Viewport Overrides for** context menu command.

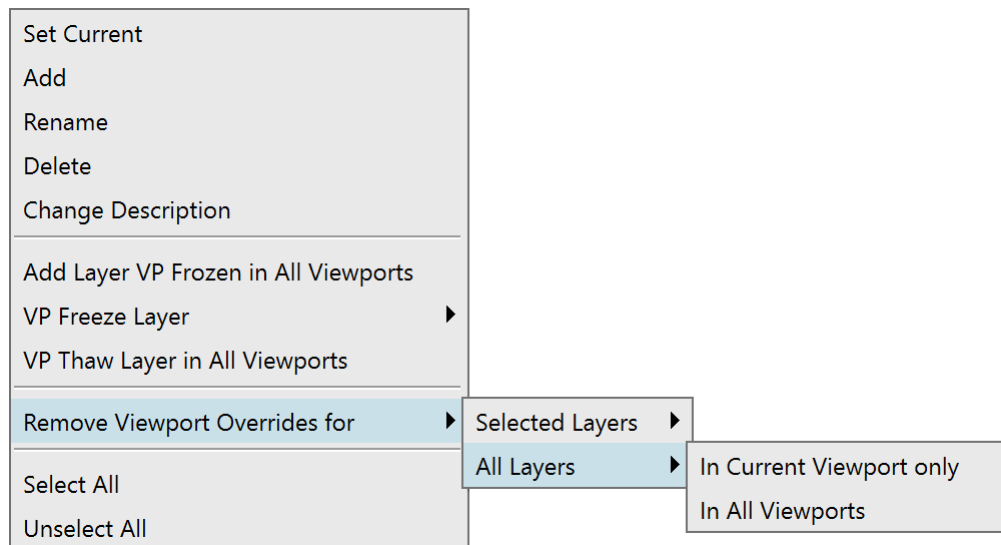



#### Command options:

**Selected Layers** Removes property overrides for selected layers.  
Removal can be made:  
**In Current Viewport only**  
**In All Viewports.**

**All Layers** Removes property overrides in all layers.  
Removal can be made:  
**In Current Viewport only**  
**In All Viewports.**

## Locking a Layer to Make Changes

Objects located on locked layers are displayed on the screen, but they cannot be edited. You can create new objects on a locked layer. For a locked layer, you can change the color, linetype and lineweight, and allow or disallow its printing.

Locked layers are indicated by the  icon, and unlocked layers are indicated by the  icon. You can lock and unlock several layers at once.

#### To lock/unlock a layer:



11. Select one or more layers in the list.
12. Left-click in the column that displays the  () icon next to the name of one of the selected layers.

There is a mode for enabling the selection of objects on locked layers to view their properties and use object snap.

#### To be able to select objects on locked layers:



In the status bar, enable the  **Select objects on locked layers** button.

## Managing Layer Availability for Plotting

The  icon displayed as an outline indicates that objects located on the layer will be plotted. Objects on layers marked with the  icon will not be plotted.

You can enable or disable printing for several layers at once.

### To prohibit/allow a layer to be plotted:

13. Select one or more layers in the list.
14. Left-click in the column that displays the  () icon next to the name of one of the selected layers.







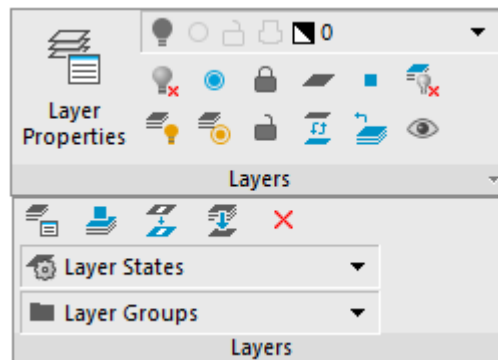





## Tools to Work with Layers



There are set of tools for quick organization of layers in nanoCAD.

You can find the commands to work with layers on the **Home** ribbon tab in the **Layers** group:



And in the menu **Format – Layer tools**:

-  Create layer
-  [Make Object's layer current](#)
-  [Layer](#) walk
-  [Match](#) layer
-  [Change to current layer](#)
-  [Copy](#) objects to new layer
-  [Isolate](#)
-  [Layer](#) off
-  [Turn](#) on all layers
-  [Layer](#) freeze
-  [Thaw](#) all layers
-  [Layer](#) lock
-  [Layer](#) unlock

-  Merge layer
-  Delete layer
-  Layer previous.

Some of these commands are on the **Layers 2** toolbar:







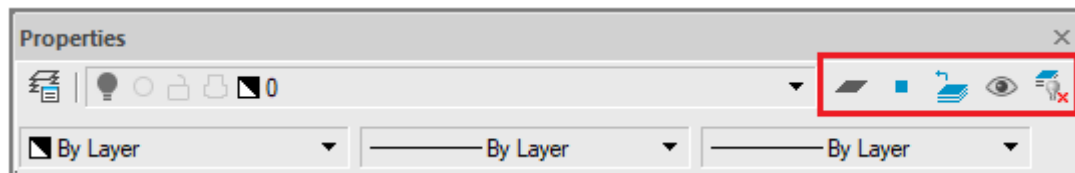

For your convenience the following commands are placed on the **Properties** toolbar:

- **Create layer**
- **Make Object's Layer Current**
- **Previous State of Layers**
- **Layer walk**
- **Isolate**



## Create Layer

-  Ribbon: **Home – Layers >**  **Create layer**
-  Menu: **Format – Layer Tools >**  **Create Layer**
-  Toolbar: **Properties –** 
-  Command line: **NEWLAYER**

The command to quickly create a layer with current properties.

By opening the **Properties** toolbar, you can immediately edit properties of a new layer.

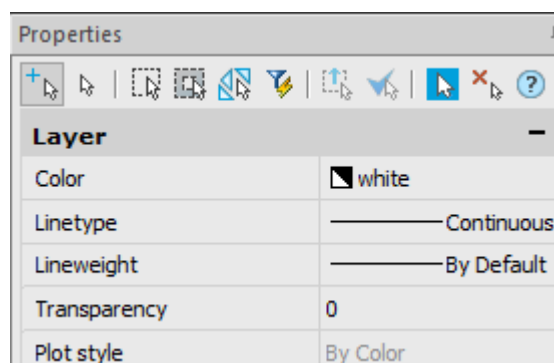

Enter the layer name in the command line or use the dynamic input, press **ENTER**.

## Make Object's Layer Current



Ribbon: **Home – Layers** >  **Make Object's Layer Current**



Menu: **Format – Layer tools** >  **Make Object's layer current**



Toolbar: **Properties** – 



Command line: **LAYMCUR**

A layer of a selected object becomes current. You can select one or several objects belonging to one layer.

### Command option:

 Starts other options to select objects.

### Command prompts:

Select object whose layer will become current or [?]:

Select an object or objects belonging to one layer.

## Layer Walk



Ribbon: **Home – Layers** >  **Layer walk**



Menu: **Format – Layer tools** >  **Layer walk**





Toolbar: **Properties** – 



Command line: **LAYWALK**

The **Layer walk** mode displays objects only on selected layers and hides objects on any other layers. Objects can be previously selected.

### To display only a current layer:

1. Select the  **Layer walk** button from the **Properties** toolbar. Visibility of all layers, except the one selected, are temporarily switched off. Near a current layer in the  column the  icon is displayed. It means that this layer is visible.



### To display only selected layer:

You can do without the **Layer walk** command to display only one layer:

1. With the **CTRL** button pressed select a layer from a layers list on the **Properties** toolbar or **Properties** window.

A selected layer becomes visible and current, visibility of all layers, except the one selected, is temporarily switched off.

### To display several selected layers:

1. Select the  **Layer walk** button from the **Properties** toolbar. Visibility of all layers, except the one selected, is temporarily switched off.
2. Click in the drop-down list of the **Properties** toolbar or **Properties** window and select other layers to display. Near selected layers in the  column the  icon is displayed. It means that these layers are visible.

3. Click on a visible layer (which has marked with the  icon) switches off its visibility.

### *To exit from display mode of several layers:*

Switching the  **Layer walk** button off on the **Properties** toolbar restores visibility of all layers.

1. Switch the  **Layer walk** button off on the **Properties** toolbar.

The visibility of all layers is restored.

## **Match Layer**



Ribbon: **Home – Layers** >  **Match layer**



Menu: **Format – Layer tools** >  **Match layer**



Toolbar: **Layers 2** - 



Command line: **LAYMCH**

The command moves selected objects to another layer. It is possible to select objects beforehand.

### *Command options:*

- ? Starts other options to select objects.
- Name Opens the **Change to Layer** dialog for selection of destination layer from the list.

### *Command prompts:*

- |   |  |
|---|--|
| Select an object to change its layer or [?]:    | Select objects.  |
| Select object on destination layer or [?/Name]: | Select objects on a layer, where you want to move objects to.                                      |
| Select object on destination layer or [?/Name]: | Select the <u>Name</u> option to specify a destination layer in the <b>Change to Layer</b> dialog. |

### *Selection of commands to work with layers in the dialogs*

The dialogs open when you select the Name option and shows list of layers, which you can select as a destination layer or layers for merging or removal.

1. In the command prompt `Select object on destination layer or [?/Name]:` select Name.
2. Select a layer from the list in the dialog.
3. Press **OK**.

### *To create a new layer:*

1. Enter a layer's name in the dialog field.
2. Press **OK**.
3. Accept a layer's creation.



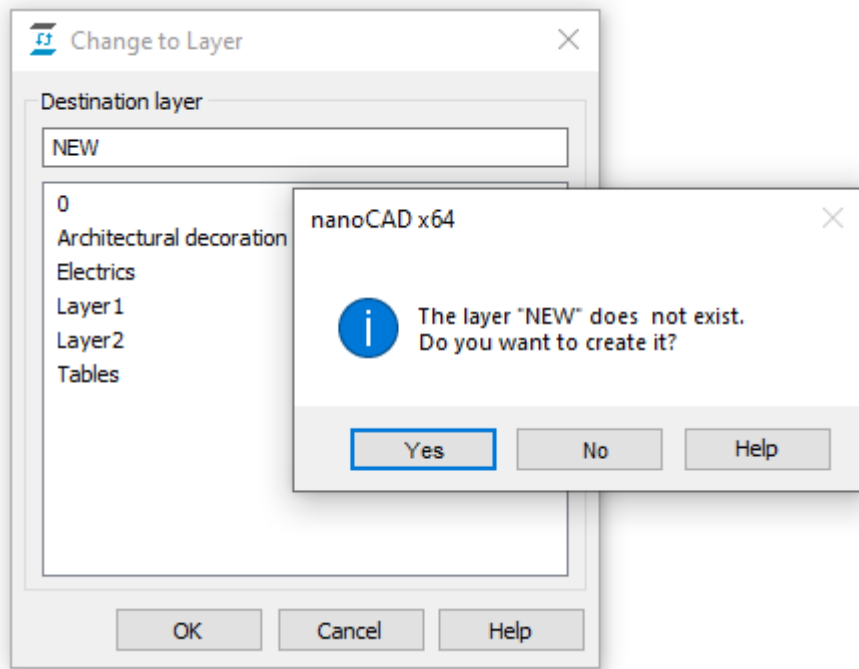

Multiple selections are acceptable when you merge or delete layers in the dialogs. With the **SHIFT** button pressed all layers are selected from the first to the last click. With the **CTRL** button pressed you can add any layer from a list to a selection.

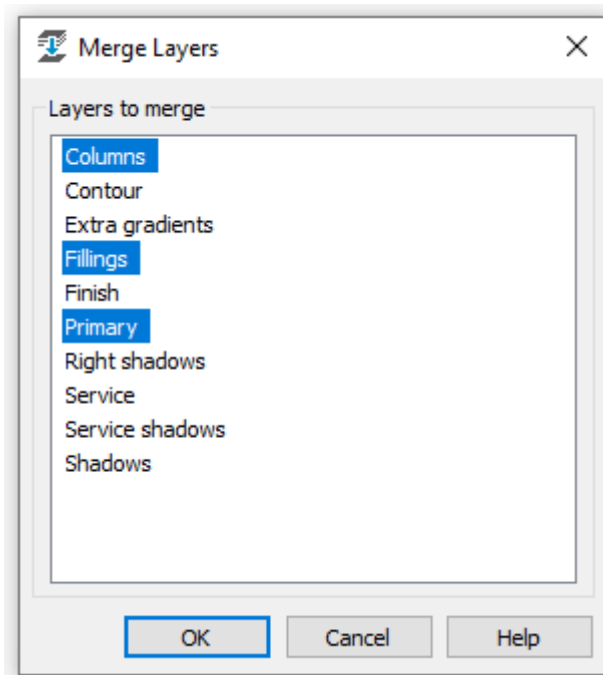

## Change to Current Layer



Ribbon: **Home – Layers** >  **Change to current layer**



Menu: **Format – Layer tools** >  **Change to current layer**



Toolbar: **Layers 2** - 



Command line: **LAYCUR**

Replaces selected objects on a current layer. Objects can be previously selected.

**Command option:**

? Starts other options to select objects.

**Command prompts:**

Select objects to be changed to the current layer or [?]:

Select objects.

Select objects to be changed to the current layer or [?]:

Press **ENTER** to finish the command.

## Copy Objects to New Layer



Ribbon: **Home – Layers** >  **Copy objects to new layer**



Menu: **Format – Layer tools** >  **Copy objects to new layer**



Toolbar: **Layers 2** - 



Command line: **COPYTOLAYER**

Creation of selected objects copies on the specified layer. For objects' copies you can specify another location. It is possible to select objects beforehand.

**Command options:**

? Starts other options to select objects.

Name Starts the **Copy to Layer** dialog to specify a layer where objects' copies are placed.

Displacement A value of displacement of objects' copies by specifying a relative distance by entering coordinates. Coordinates specify a displacement value of objects' copies not a point location.

Exit Completes the command without objects' replacement.

**Command prompts when specifying a base point**

Select an object to change its layer or [?]:

Select objects.

Select object on destination layer or [?/Name]:

Select an object on a layer to place copies.

Select object on destination layer or [?/Name]:

Select Name option to specify a layer in the **Copy to Layer** dialog.

Specify base point or [Displacement/Exit]

Specify a base point to replace the copied objects.

Specify second point or displacement <use first point as displacement>

Specify a second point for replacement.

**Command prompts when you replace copies:**

Specify base point or [Displacement/Exit]

Select Displacement.

Specify displacement:

Enter coordinates values, which specify relative distance and direction.

## Isolate



Ribbon: **Home – Layers** >  **Isolate**



Menu: **Format – Layer tools** >  **Isolate**



Toolbar: **Layers 2** - 



Command line: **LAYISO**

Switches all layers off, except layers of selected objects. Layers of selected objects remain visible and are called isolated.

The command allows freezing all layers except selected only in a current viewport (with the specified parameter Viewports = Vpfreeze).

### Command options:

?

Starts other options to select objects.

Settings

Switches to a selection mode of parameters' type. Selected parameters are saved for following program sessions.

The option starts the following prompt in the command line:

#### Options:

Off

- Turns off all layers except for layers of selected objects.

Lock

- Locks all layers except for layers of selected objects.

In paper space viewport use [Vpfreeze/Off]:

#### Options:

Vpfreeze

- Freezes all layers except layers of selected objects only in a current viewport.

When objects are selected in model or paper space, layers are turned off in all spaces (in model, in layout and in viewports) , except layers of selected objects.

Off

- Freezes all layers in all spaces (in model, in layout and in a current viewport), except layers of selected objects only in a current viewport.

### Command prompts when isolating layers:

Select objects on the layer(s) to be isolated or [?/Settings]:

Select objects of the layers, which need to be isolated in the drawing.

Press **ENTER** to finish the command.

### Changing the command settings

Select objects on the layer (s) to be isolated or [?/Settings]:

Enter setting for layers not isolated [Off/Lock]

Select the Settings option

Select the option for not isolatewd layers:

Off – turn off all layers except for layers of selected objects;

Lock – lock all layers except for layers of selected objects.

### Command prompts when isolating layers in a current viewport:

Select objects on the layer(s) to be isolated or [?/Settings]:

In paper space viewport use [Vpfreeze/Off] <Vpfreeze>:

Select objects on the layer(s) to be isolated or [?/Settings]:

In paper space viewport use [Vpfreeze/Off] <Vpfreeze>:

Select objects on the layer(s) to be isolated or [?/Settings]:

Select objects on the layer(s) to be isolated or [?/Settings]:

Select Settings option.

Select Vpfreeze option.

Select objects of the layers, which need to be isolated.

Select Off option to isolate layers in all spaces from a current viewport.

Select objects of the layers, which need to be isolated in all spaces.

Press **ENTER** to finish the command.

## Layer Off



Ribbon: **Home – Layers** >  **Layer off**



Menu: **Format – Layer tools** >  **Layer off**



Toolbar: **Layers 2** - 



Command line: **LAYOFF**

Turning the layers of selected objects off. It makes these objects invisible both in model and paper spaces.

The commands allows to freeze layers of selected objects only in a current viewport (if Viewports = Vpfreeze parameter is selected).

### Command options:

?

Starts other options to select objects.

Settings

Switches to the selection parameters mode. Selected parameters are saved for the next session.

The option starts the following prompt in the command line:

Enter setting type for [Viewports]:

#### Options:

Viewports - Switches to the selection parameters mode for a current viewport. The option starts the following prompt in the command line:

In paper space viewport use [Vpfreeze/Off] <Vpfreeze>:

#### Options:

Vpfreeze - Freezes layers of selected objects only in a current viewport.

If objects are selected in paper or model spaces, their layers are turned

off in all spaces (model, paper, and viewports).

Off - turns layers of selected objects off. Layers are turned off in all spaces and it does not matter where objects of these layers are selected (model or paper spaces, in a current viewport).

**Option:**

Block selection-Displays options for block definition:

Block - If the selected object is nested in a block, the layer containing this block is turned off. If the selected object is nested in the external reference, the layer of this object is turned off.

Entity - Turns off the selected objects, even if they are nested in an external reference or in a block.

None - If a block or an external reference is selected, turns off the layer containing this block or this external reference

Undone Cancels selection of previous layer to be turned off (or frozen in a current viewport).

**Command prompts when layers are turned off:**

Select an object on the layer to be turned off or [?/Settings]:

Select objects of the layers which is needed to be turned off.

Select an object on the layer to be turned off or [?/Settings/Undone]:

Select Undone option to cancel turning the previous layer off.

Select an object on the layer to be turned off or [?/Settings/Undone]:

Press **ENTER** or **ESC** to finish the command.

**NOTE:** Command prompts are shown for **Off** option of **Viewports** parameter.

**Command prompts when layers are turned off in a current viewport:**

Select an object on the layer to be turned off or [?/Settings]:

Select Settings option.

Enter setting type for [Viewports]:

Select Viewports option.

In paper space viewport use [Vpfreeze/Off] <Vpfreeze>:

Select Vpfreeze option.

Select an object on the layer to be turned off or [?/Settings]:

In a viewport select objects of the layers which are needed to be turned off.

Select an object on the layer to be turned off or [?/Settings/Undone]:

Select Undone option to cancel turning the previous layer off.

Select an object on the layer to be turned off or [?/Settings/Undone]:

Press **ENTER** or **ESC** to finish the command.

**NOTE:** Command prompts are shown for **Off** option of **Viewports** parameter.

**Command prompts when layers are turned off in the block selection:**

Select an object on the layer to be turned off or [?/Settings]:

Select the Settings option.

Enter setting type for [Viewports/Block selection]:

Select the Block selection option.

Enter Block Selection nesting level

Select the option for the nesting

[Block/Entity/None/]

Select an object on the layer to be turned off or [[?/Settings](#)]:

Select an object on the layer to be turned off or [[?/Settings/Undone](#)]:

level.

Specify in the drawing the objects of the layers to be turned off.

Press **ENTER** or **ESC** to complete the command.

## Turn on All Layers



Ribbon: **Home – Layers** >  **Turn on all layers**



Menu: **Format – Layer tools** >  **Turn on all layers**



Toolbar: **Layers 2** - 



Command line: **LAYON**

The command turns on all previously turned off layers. Objects created on these layers become visible if layers were not frozen.

## Layer Freeze



Ribbon: **Home – Layers** >  **Layer freeze**



Menu: **Format – Layer tools** >  **Layer freeze**



Toolbar: **Layers 2** - 



Command line: **LAYFRZ**

Freezing the layers of selected objects. It makes these objects frozen both in model and paper spaces.

The commands freeze layers of selected objects only in a current viewport (if [Viewports=Vpfreeze](#) parameter is selected).

### Command options:

[?](#)

Starts other options to select objects.

[Settings](#)

Switches to the selection parameters mode. Selected parameters are saved for the next session.

The option starts the following prompt in the command line:

Enter setting type for [[Viewports](#)]:

#### Options:

[Viewports](#) - Switches to the selection parameters mode for a current viewport. The option starts the following prompt in the command line:

In paper space viewport use [[Freeze/Vpfreeze](#)] <Vpfreeze>:

#### Options:

[Freeze](#) - Freezes layers of selected objects. Layers are frozen in all spaces and it does not matter where objects of these layers are selected (model or paper spaces, in a current viewport).

[Vpfreeze](#) - Freezes layers of selected objects only in a current

viewport.

If objects are selected in paper or model spaces, their layers are frozen in all spaces (model, paper, in viewports).

**Option:**

Block selection-Displays options for block definition:

Block - If the selected object is nested in a block, the layer of this block is frozen. If the selected object is nested in the external reference, the layer of this object is frozen.

Entity - Freezes layers of the selected objects, even if they are nested in an external reference or in a block.

None - If a block or an external reference is selected, freezes the layer containing this block or this external reference

Undone Cancels selection of previous layer to be frozen.

**Command prompts when layers are frozen:**

Select an object on the layer to be frozen or [?/Settings]:

Select an object on the layer to be frozen or [?/Settings/Undone]:

Select an object on the layer to be frozen or [?/Settings/Undone]:

Select objects of the layers which is needed to be frozen.

Select Undone option to cancel freezing the previous layer.

Press **ENTER** or **ESC** to finish the command.

**NOTE:** Command prompts are shown for **Freeze** option of **Viewports** parameter.

**Command prompts when layers are frozen in a current viewport**

Select an object on the layer to be frozen or [?/Settings]:

Enter setting type for [Viewports]:

In paper space viewport use [Freeze/Vpfreeze] <Vpfreeze>:

Select an object on the layer to be frozen or [?/Settings]:

Select an object on the layer to be frozen or [?/Settings/Undone]:

Select an object on the layer to be frozen or [?/Settings/Undone]:

Select Settings option

Select Viewports option.

Select Vpfreeze option.

In a viewport select objects of the layers which should be frozen.

Select Undone option to cancel freezing the previous layer.

Press **ENTER** or **ESC** to finish the command.

**NOTE:** Command prompts are shown for **Freeze** option of **Viewports** parameter.

**Command prompts when freezing layers in the block selection:**

Select an object on the layer to be frozen or [?/Settings]:

Enter setting type for [Viewports/Block selection]:

Enter block selection nesting level [Block/Entity/None/]

Select an object on the layer to be frozen or [?/Settings]:

Select the Settings option.

Select the Block selection option

Select the option for the nesting level.

Specify in the drawing the objects of the layers to be

Select an object on the layer to be frozen  
or [?/Settings/Undone]:

frozen.

Press **ENTER** or **ESC** to  
complete the command.

## VP Freeze Layer in All Viewports Except Current



Command line: **LAYVPI**



The context menu on the **Layers** functional bar or in the **Layers** dialog: **VP Freeze Layer > In All Viewports Except Current**

Freezes a layer in all layout viewports except the current one. The command runs only in paper space for two or more viewports.

### Command options:

Settings Switches to setting type selection mode. The selected settings are saved for subsequent sessions of the program. The option initiates the following prompt in the command line:

Enter setting type [Layouts/Block selection]:

Layouts Switches to the mode for selecting settings for layouts. When you select an option in the command line, the following prompt is displayed:

Isolate layer in all viewports except current for [All layouts/Current layout] <Current layout>:

All layouts – freeze the layers of selected objects in all viewports, except the current one, on all layouts;

Current layout – freeze the layers of selected objects in all VPs except the current one, only in the current layout.

Block selection Switches to settings selection mode for block definitions. When you select an option, the following prompt is displayed in the command line:

Enter Block Selection nesting level [Block/Entity/None] <Block>:

Block – if the selected object is included in a block, then the block's (not the object's) layer is isolated in all VPs except the current one. If the selected object is included in an external reference, then the layer of the object (not of the external reference) is isolated in all VPs except the current one;

Entity – if the selected object is included in a block or external reference, then the layer of the object (not of the block/external reference) is isolated in all VPs except the current one;

None – if the selected object is included in a block or external reference, then the layer of the block/external reference (not of the object) is isolated in all VPs except the current one.

Undone Deselects the previous layer to freeze it.

### Command prompts:

Current settings: Layouts=Current layout, Block nesting level=Block

Displays previous settings.

Select an object on the layer to be isolated in viewport or [Settings]:

To change previous settings, select the Settings option.

Enter setting type [Layouts/Block selection]:

Change settings for Layouts and/or Block Selections as needed.



Select an object on the layer to be isolated in viewport or [[Settings/Undone](#)]:

Indicate in the viewport the objects of layers to be frozen in all VPs except the current one. Select the Undone option to cancel the previous freeze.

Press **ENTER** or **ESC** to complete the command.

## Thaw All Layers

 Ribbon: **Home – Layers** >  **Thaw all layers**

 Menu: **Format – Layer tools** >  **Thaw all layers**

 Toolbar: **Layers 2** - 

 Command line: **LAYTHW**

The command unfreezes all previously frozen layers. Objects created on those layers become visible if layers are not also turned off or were not frozen in separate viewports. You can successively unfrozen layers frozen in separate layout viewports one by one or use the [VP Thaw Layer in All Viewports](#) command of the layer context menu in the **Layers** dialog/functional bar.

## Layer Lock

 Ribbon: **Home – Layers** >  **Layer lock**

 Menu: **Format – Layer tools** >  **Layer lock**

 Toolbar: **Layers 2** - 

 Command line: **LAYLCK**

Locks layers of selected objects. The command allows forbidding accidental changing of any layer objects. Objects or an object can be previously selected.

### Command option:

 Starts other options to select objects.

### Command prompts:

Select an object on the layer to be locked or []:

Select an object.

## Layer Unlock

 Ribbon: **Home – Layers** >  **Layer unlock**

 Menu: **Format – Layer tools** >  **Layer unlock**

 Toolbar: **Layers 2** - 

 Command line: **LAYULK**

Unlocks layers of selected objects. Objects or an object can be previously selected.

**Command option:**

? Starts other options to select objects.

**Command prompts:**

Select an object on the layer to be unlocked or [?]:

Select an object.

## Merge Layer



Ribbon: **Home – Layers** >  **Merge layer**



Menu: **Format – Layer tools** >  **Merge layer**



Command line: **LAYMRG**

Merges selected layers into a specified layer. Objects on merged layers are moved to the specified layer and the initial layers are purged.

**Command options:**

? Starts other options to select objects.

Name Opens the **Merge layers** dialog to specify objects or layers to merge.

**Command prompts:**

Select object on layer to merge or [?/Name]:

Select objects on merged layers.

Select object on layer to merge or [?/Name]:

Select Name option for selection of layers in the list of the **Merge layers** dialog.

Select object on layer to merge or [?/Name]:

Press **ENTER** to finish selection.

Select object on target layer or [?/Name]:

Select object on a layer where objects of merged layers are replaced.

Select object on target layer or [?/Name]:

Select Name option for selection of target layer in the list of the **Merge to Layer** dialog.

## Delete Layer



Ribbon: **Home – Layers** >  **Delete layer**



Menu: **Format – Layer tools** >  **Delete layer**



Command line: **LAYDEL**

Removal of layers. Objects can be previously selected.

**Command options:**

? Starts other options to select objects.

Name Opens the **Delete Layers** dialog to specify layers to be deleted.

### Command prompts:

Select object on layer to delete  
or [?/Name]:

Select object on layer to delete  
or [?/Name]:

Select objects of layers to be deleted.

Select Name option for selection of layers to be deleted in the list of the **Delete layers** dialog.

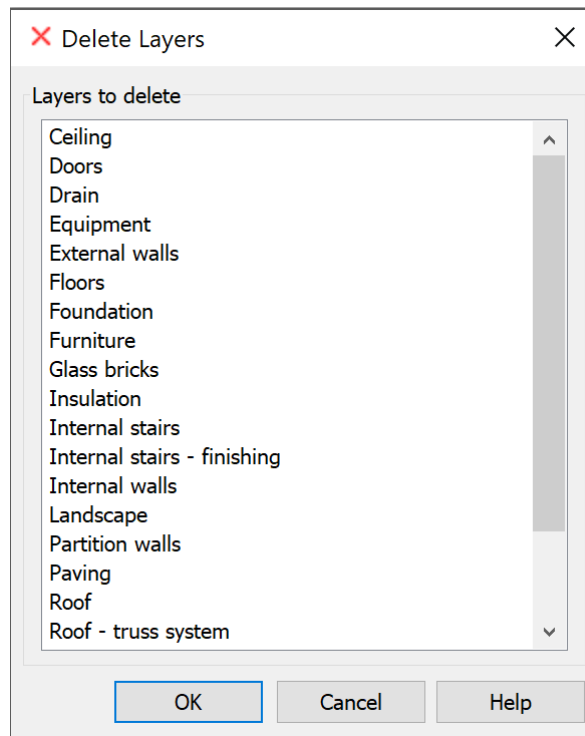

Selected layers:

Select object on layer to delete  
or [?/Name]:

Press **ENTER** to finish the command.

## Previous State of Layers



Ribbon: **Main – Layers** >  **Layer previous**



Manu: **Format – Layer tools** >  **Layer previous**



Command line: **LAYERP**

Successively undoes the last changes of layer states and properties.

## Line Types



Ribbon: **Home – Annotation** >  **Line Types**



Menu: **Format –  Styles...**



Command line: **LINETYPE**

Different line types have different purposes; for example, to create axes you use one type of line, another to create invisible lines etc. Using different line types to create different objects improves visual perception of graphic data and makes working with drawings more efficient.

Line type is a repeated sequence of lines, dots and spaces along a line or curve. Complex types of lines can contain *built-in shapes* which are stored in the (\*.SHP) *shape file*. Line types are stored in files with a \*.LIN extension. Every type has its own name; sequence of dashes, points, relative lengths of dashes and spaces and other characteristics are specified in a line's description. One LIN-file can contain many line types.

nanoCAD supports line types created for AutoCAD.

Users can create their own line types by adding their descriptions to an existing LIN-file or creating their own new files. Edit an existing file or create a new file in any text editor or text processor.

User line types (\*.LIN) and shape files (\*.SHP), which are used in line types are stored in `C:\ProgramData\Nanosoft AS\nanoCAD Int 24.0\SHX` folder.

There is a built in **Linetype editor** to create user line types and edit existing ones.

Before using a line type, you have to load it into the drawing. Loaded line types can be renamed when you are working with the drawing. Renaming a line type only changes its description in the current drawing; the name of the line type stays the same in the LIN-file.

Unused line types can be deleted in the **Linetype Manger** with the **Purge** command (**File** menu – **Drawing Utilities**).

---

**NOTE: By layer, By block and Solid line** types cannot be renamed or deleted.

---

All newly created objects inherit the line type currently set in the **Linetype** row of the **Properties** bar.

---

**NOTE: The Linetype** drop-down list of the **Properties** -bar only contains loaded line types, shown in the **Linetype Manager**.

---

If a current line type is specified **By layer**, new objects will have the line types defined for this layer.

Line types can be assigned not only to layers, but also to objects. To change an object's line type, replace it on the layer with another line type, change the line type of the layer where it is placed or specify another line type especially for the object.

Line types are saved with the document in the \*.dwg file. They can be saved in a (\*.dwt) file template to transfer to another computer.

Information about all line types in the document is shown in the **Linetype Manger**. **Linetype Manager** allows loading, deleting and renaming of line types. There is a button  to open the built-in **Edit Linetype** dialog box, which allows you to create own line types or edit existing line types.

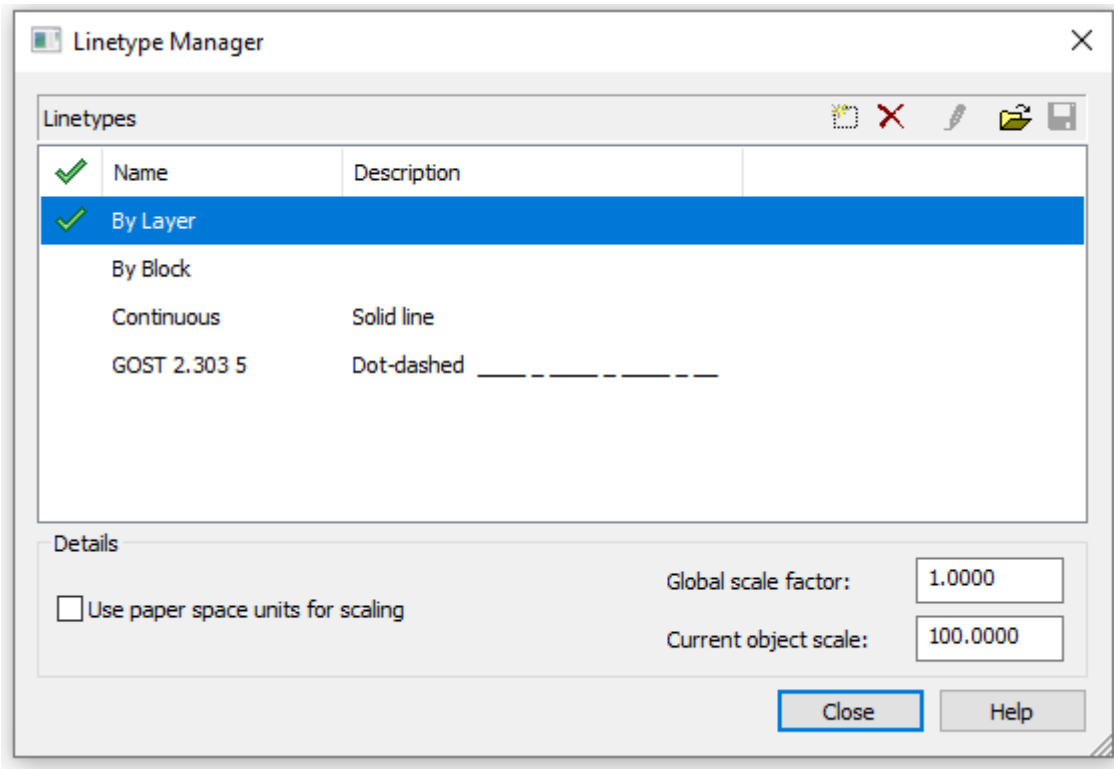

### Parameters:

#### Line types

Shows the list of line types loaded in the current document.



#### Status

Displays and sets the current line type.

#### Name

Displays and edits the name of selected line type.

#### Description

Displays and edits the face and text description of selected line type.

#### Buttons



#### Add linetype

Creates a new style of line type using a selected type from the list as a base.



#### Delete linetype

Removes the selected line type from the current document.



#### Edit linetype

Opens the [Edit Linetype](#) dialog box.



#### Open linetype

Imports line types into the current document.



#### Save linetype

Saves the selected line types into a file with \*.LIN extension.

#### Details

#### Use paper space units for scaling

Sets the same scale of line types for paper space and model space. This option is useful if you use several viewports at once.

#### Global scale factor:

Sets a global scale factor for all line types.

**Current object scale:** Sets the scale factor for line types for newly created objects. The scale is a multiplication of the global scale and the current scale.

**NOTE:** There is a context menu in the **Linetype Manger**:

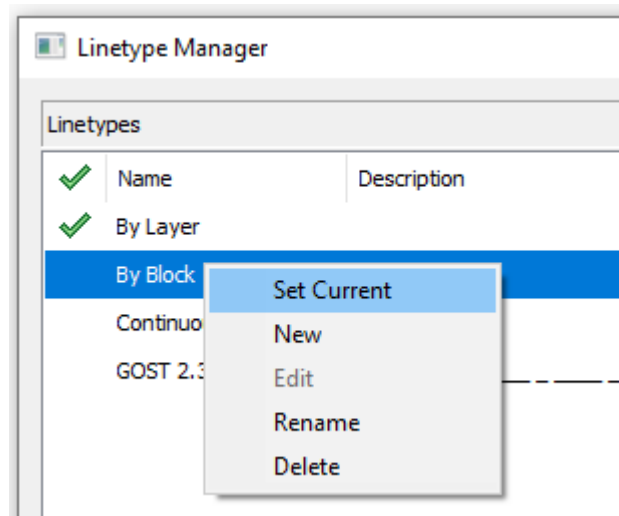

**To set a line type as current:**

1. Select the required line type in the dialog box.
2. Click in the left field of the selected line type. The  tag appears, the line type is set as current.

**To import line types:**

1. Click the  **Load line type**.
2. In the **Open Line Type Import** dialog box, specify the path to load the line type file (\*.LIN), containing the descriptions of the line types.
3. In the **Load/Reset Line Types** dialog box, select the line types for import. To select several line types, use the **SHIFT** or **CTRL** buttons. To select all linetypes at once, click **Select All**

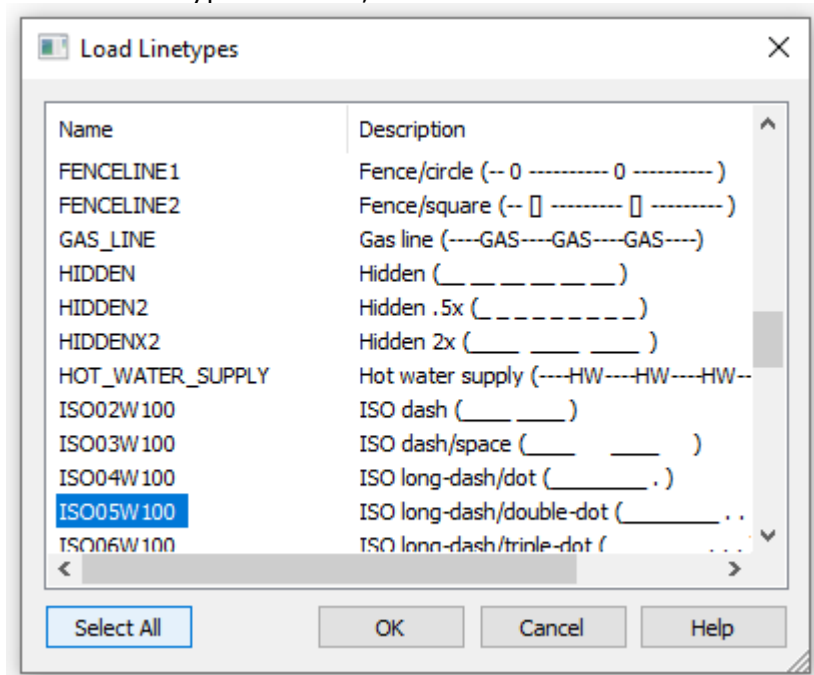

4. Click **OK** to start loading the selected line types.

- Click **OK** to close the **Linetype Manger** dialog box.

You can load linetypes from the Properties bar by selecting the Load item in the Linetype field:

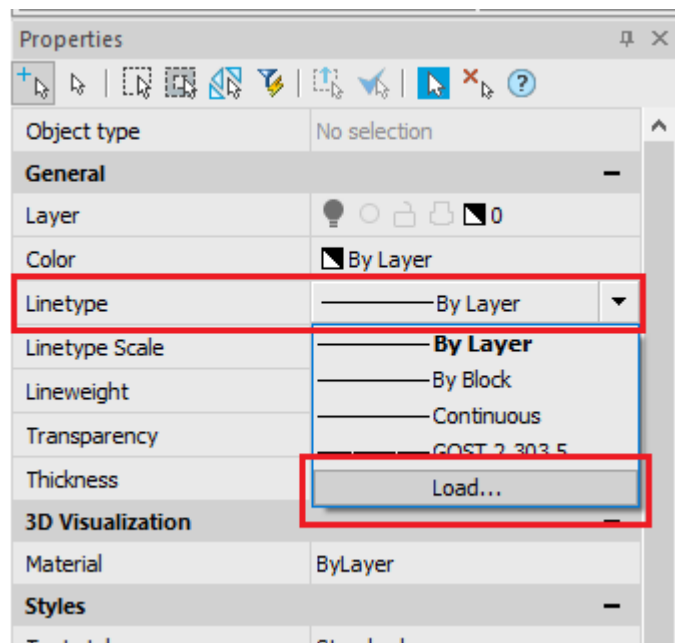

#### *To save line types:*

- In the dialog box, select one or several line types to export (you can use **SHIFT** and **CTRL** buttons).
- Click the  **Save linetype** button.
- In the **Save Line Type Import** dialog select the folder and specify a name.
- Click the **Save** button.
- Click **OK** to close the **Linetype Manger** dialog box.

#### *To delete a line type:*

- In the dialog box, select one or several line types to delete (you can use **SHIFT** and **CTRL** buttons).
- Click the  **Delete** button.
- Click **OK** to close the **Linetype Manger** dialog box.

## *Edit Linetype*

In the [Linetype Manager](#) you can edit the selected line type or create a new one using the built-in **Linetype Editor**:

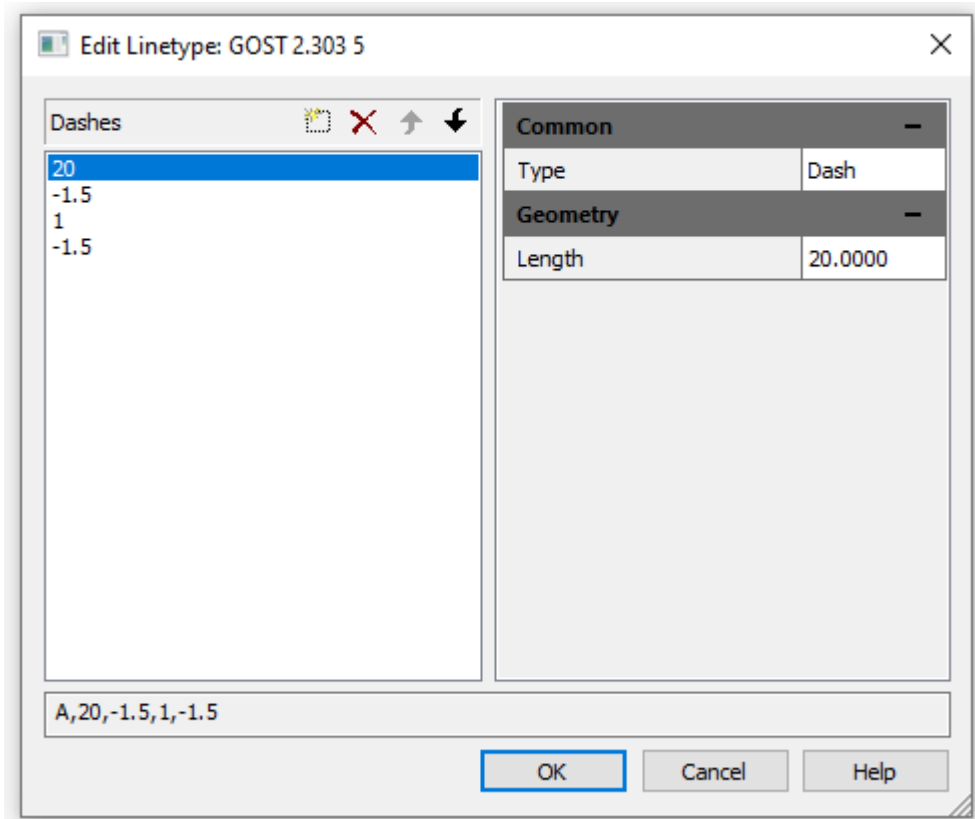

### Parameters:

#### Description of line types

Description of line types is shown.

#### Buttons



#### Add dash

Adds a new element to the line.



#### Delete dash

Deletes an element from the line.



#### Move dash up

Moves one element up.



#### Move dash down

Moves one element down.

Common	
Type	Dash

Elements are selected in the **Common** section.

There are the following options in the drop-down list:

- **Dash**
- **Text**
- **Shape**

Geometry	
Length	0.0000

An element's value is shown in the **Geometry** section.



### To edit a line type:

1. Select a line type in the [Linetype Manager](#).
2. Click the  **Edit linetype** button to start the built-in **Linetype Editor**. There is a description of the selected line type in the **Dashes** field:

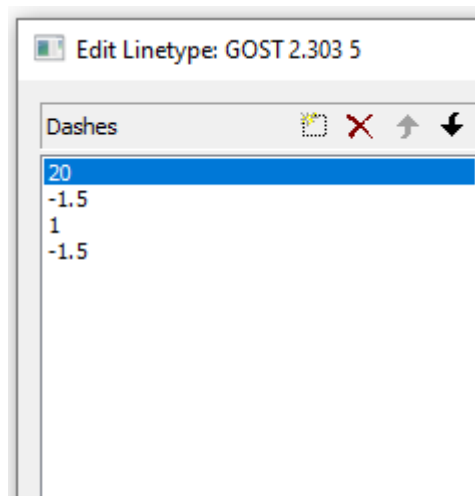

3. Select an element and enter its new value in the **Length** field of the **Geometry** section.

**NOTE:** When you specify a positive value, a dash is drawn, when you specify a negative value, a space is drawn, when a value is zero a point is drawn.

**NOTE:** The length of the first element must be greater than or equal to zero, i.e. the dash or point must be drawn first.

4. To display a new value, press **ENTER** or just click.
5. To add a new element, click the  **Add dash** button. A new element is added to the end of the list and a zero value is assigned to it by default.
6. Specify a new value for an added element in the **Length** field of the **Geometry** section. To display a new value press **ENTER**.
7. Click **OK** to close the **Edit Linetype** dialog box.
8. Click **OK** to close the **Linetype Manger** dialog box.

### To add text to a description of a line type:

1. In the **Type** field select the **Text** option:

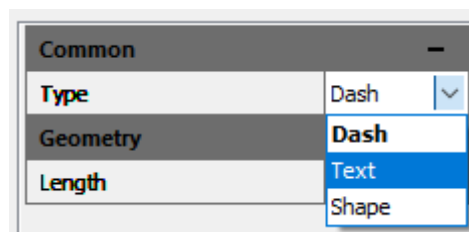

2. In the **Style** field of the **Text** section, select a text style from the drop-down list. In the **Text** field enter symbols, specify parameters in the **Geometry** section:

<b>Common</b> —	
Type	Text
<b>Text</b> —	
Style	Standard
Text	Text
<b>Geometry</b> —	
Length	20.0000
Scale	1.0000
Rotation	0
Absolute Rotation	No
Upright	No
Offset X	0.0000
Offset Y	0.0000

3. Click **OK** to close the **Edit Linetype** dialog box.
4. Click **OK** to close the **Linetype Manger** dialog box.

*To add a shape to a description of a line type:*

1. In the **Type** field select the **Shape** option:

<b>Common</b> —	
Type	Dash ▾
<b>Geometry</b> —	
Length	Dash Text <b>Shape</b>



2. Select a shape name from the drop-down list in the **Name** field and a shape file in the **File** field of the **Shape** section. Specify required parameters in the **Geometry** section:

<b>Common</b> —	
Type	Shape
<b>Shape</b> —	
File	GOST 2.30...
Name	WAVE
<b>Geometry</b> —	
Length	20.0000
Scale	1.0000
Rotation	0
Absolute Rotation	No
Upright	No
Offset X	0.0000
Offset Y	0.0000

3. Click **OK** to close the **Edit Linetype** dialog box.
4. Click **OK** to close the **Linetype Manger** dialog box.

## Creation of a New Linetype

A new line type is created on the base of an existing one:

1. In the **Linetype Manager** select a line type.
2. Click the  **New linetype** button. The new row has a default name – *Linetype1* appears.
3. Click *Linetype1* and enter a new name.
4. In the **Description** field enter information about the line type.
5. Click the  **Edit linetype** button.
6. Change the parameters in the **Edit Linetype** dialog box.
7. Click **OK** to close the **Edit Linetype** dialog box.
8. Click **OK** to close the **Linetype Manager** dialog box.

## Brief Description of the Procedure for Creating Custom Linetypes

You can view and, if necessary, edit the content of GOST 2.303-68.lin file in any text editor that saves data in ASCII format:

```
;;
;; linetypes by GOST 2.303-68
;;

*GOST2.303 3,Solid wavy ~~~~~
A,0.001,[WAVE,GOST 2.303-68.shx],-26
*GOST2.303 4,Dashed _ _ _ _ _
A,5,-2,0
*GOST2.303 5,Dash-dot thin _ _ _ _ _
A,20,-1.5,1,-1.5
*GOST2.303 6,Dash-dot theckened _ _ _ _ _
A,8,-1.5,1,-1.5
*GOST2.303 8,Solid thin kinks ---'\---'\---'\---'\---'\---
A,40,[BREAK,GOST 2.303-68.shx],-8
*GOST2.303 9,Dash-dot with two dots _.._.._.._.._.._.._.._.._.._
A,20,-1.5,1,-1.5,1,-1.5
```

Lines that start with a semicolon (;) character are comments.

Description of a linetype consists of 2 lines: the first line contains the linetype name and a short description, the second line specifies the linetype outline.

```
*GOST2.303 5,Dash-dot thin _ _ _ _ _
A,20,-1.5,1,-1.5
```

An asterisk is placed before the linetype name. The name should be unique.

```
*GOST2.303 5
```

The linetype name is separated from a short description by a comma.

```
*GOST2.303 5,Dash-dot thin _ _ _ _ _
```

A brief description consists of a text part explaining the purpose of the linetype (for example, the explanation *Dash-dot* can be changed to the following: *To draw center lines*). The description often includes a sequence of text characters (dashes, spaces, dots, etc.) that visually resembles

this line. The description can be up to 47 characters long. The description is optional and can be omitted. If there is no description, no comma is placed after the linetype name.

The second line containing the linetype description begins with the character *A*, which defines the type of alignment.

Further, separated by commas (without spaces), write the linetype elements that specify the line style.

```
A,20,-1.5,1,-1.5
```

As elements of the linetype outline, the following can be used:

- zero – specifies a dot construction;
- positive decimal numbers – specify the construction of dashes (a number value determines the dash length in drawing units);
- negative decimal numbers – specify the construction of spaces (a number value determines the space length in drawing units);
- text objects;
- embedded shapes stored in form files.

Linetypes described by dashes, dots and spaces are called *simple*. The *complex linetypes* include the ones described by text objects and embedded shapes. Linetypes that include text objects and embedded shapes are used in utility network signs, in topographic symbols, and so on.

In the GOST 2.303-68.lin file the linestypes *\*GOST2.303 4*, *\*GOST2.303 5*, *\*GOST2.303 6* and *\*GOST2.303 9* are *simple*, the linetypes *\*GOST2.303 3* and *\*GOST2.303 8* are *complex*, because their descriptions use the embedded shapes *WAVE* and *BREAK*.

Alignment type *A* determines the condition according to which lines should begin and end with dashes, i.e. the value that determines the length of the first segment of the line should be greater than or equal to zero.

In order to better understand what alignment is and how it works, consider an example of drawing a line segment from point 1 to point 2 using *Dash-Dot* linetype. The program will construct a segment in such a way that it starts at point 1 and ends at point 2 with dashes. If necessary, the first and last dashes can be lengthened to meet the alignment condition. For a short segment, if it does not contain even one link *long\_dash-space-short\_dash-space*, the program will draw one dash (continuous line).

The linetype description line should not exceed 80 characters.

For each linetype it is possible to define no more than 12 elements.

In the linetype description, it is enough to specify one repeating fragment (link). For example, for the *Dash-dot* linetype such fragment is the link *long\_dash-space-short\_dash-space*.

The format for determining a simple linetype is:

```
A,Length1,Length2,Length2,...
```

Text objects are generally described in a complex linetype definition in the following format:

```
["Text",Style,Scale,Rotation_angle,Offset_X,Offset_Y]
```

The format for writing the embedded shape in the definition of a complex linetype:

```
[Name,File]
```

or

```
[Name,File,Scale,Rotation_angle,Absolute_rotation,Offset_X,Offset_Y]
```

**Parameters:**

Option	Brief information about the option	Value examples
<b>Length</b>	The length of dash or space in drawing units.	Values can be positive or negative numbers: <code>20, -1.5, 0.001</code> Value <i>0</i> – constructing a point.
<b>Text</b>	Text symbols used in a complex line. The option is used to describe a text object.	Any set of text symbols: <code>C, D, UK, W1, K1.</code>
<b>Style</b>	The name of a text style. The option is used to describe a text object.	The default style is <code>Standard</code> A style is available for selection in the drop-down list <code>GOST 2.304</code>
<b>Name</b>	Shape name. The option is used to describe an embedded shape. Mandatory parameter – if it is absent, the linetype is not defined. If there is no form in the specified file ( <b>File</b> option), the line is constructed without a shape.	<code>WAVE, BREAK, LINE FEED</code>
<b>File</b>	The name of compiled (*.shx) file containing a shape definition. The option is used to describe an embedded shape. Mandatory parameter – if it is absent, the linetype is not defined. If there is no form file, a line is drawn without a shape.	<code>GOST 2.303-68.shx</code>
<b>Scale</b>	The scale factor by which the height of the text style or the original height of the shape is multiplied. The format of the entry in the linetype description: <code>S=value.</code> If the height of the text style or the initial height of the shape are equal to <i>0</i> , then the specified value of the <i>S</i> = parameter is used as the height.	<code>S=3, S=0.1, S=.1</code>

Option	Brief information about the option	Value examples
<b>Rotation angle</b>	<p>The angle of rotation of a text object or embedded shape relative to the line direction.</p> <p>The format of the entry in the linetype description:</p> <p><code>R=value.</code></p> <p>It is allowed not to specify the parameter, in this case its value is assumed to be 0.</p>	<p>R=0, R=30, R=-90</p>
<b>Absolute rotation angle</b>	<p>The angle of rotation of a text object or embedded shape relative to the coordinate origin, i.e. all text objects or all shapes rotate the same regardless of their position relative to the line.</p> <p>The format of the entry in the linetype description:</p> <p><code>A=value.</code></p> <p>It is allowed not to specify the parameter, in this case its value is assumed to be 0.</p>	<p>A=0, A=45, A=-30</p>
<b>Offset by X</b>	<p>The offset of a text object or embedded shape by X axis directed along the line.</p> <p>The format of the entry in the linetype description:</p> <p><code>X=value.</code></p> <p>The parameter <math>X=0</math> is set when describing a continuous line containing text objects or embedded shapes.</p> <p>It is allowed not to specify the parameter, in this case its value is assumed to be 0.</p> <p>The parameter <math>S=</math> does not affect the X offset.</p>	<p>X=5, X=-2.5, X=0.01</p>

Option	Brief information about the option	Value examples
<b>Offset by Y</b>	<p>The offset of a text object or embedded shape by Y axis perpendicular to the line.</p> <p>The format of the entry in the linetype description:</p> <pre>Y=value.</pre> <p>The parameter <math>Y=0</math> is set when describing a complex line containing text objects or embedded shapes without offset by Y.</p> <p>It is allowed not to specify the parameter, in this case its value is assumed to be 0.</p> <p>The parameter <math>S=</math> does not affect the Y offset.</p>	<pre>Y=0.01, Y=-3.5, Y=7</pre>

### Linetypes examples:

1. Definition of a simple linetype *Dash-dot thin*:

```
*GOST2.303 5,Dash-dot thin _____
A,20,-1.5,1,-1.5
```

specifies the construction of a line that starts with a dash of 20 drawing units length followed by a space of 1.5 drawing units, then a dash of 1 drawing unit is built, then again a space of 1.5 units. This fragment (link) is repeated throughout the segment, ending at the end point with a dash of 20 drawing units:



2. Definition of a complex linetype *Funny*, containing text symbols 8 and )):

```
*Funny,Example of a custom linetype
A,10,-10,0.001,["8)","",Standard,S=5,R=-90,X=-3,Y=3],-10
```



3. Definition of a complex linetype *Arrow1* containing text symbols < and >:

```
*Arrow1,Single arrow
A,0.001,["<","Standard,S=5,Y=-2.5],25,[">","Standard,S=5,X=-2.5,Y=-2.5],-20
```



4. Definition of a complex linetype *Arrow2* containing text symbols < and >:

```
*Arrow2,Double arrow
A,0.001,["<","Standard,S=5,Y=-2.5],0,["<","Standard,S=5,X=3,Y=-2.5],25,
[">","Standard,S=5,X=-2.5,Y=-2.5],0,[">","Standard,S=5,X=-5.5,Y=-2.5],-20
```



5. Definition of a complex linetype *GOST2.303 8* containing the embedded shape *BREACK*:

```
*GOST2.303 8,Continuous jogged line ---'\---'\---'\---'\---'\---
A,40,[BREAK,GOST 2.303-68.shx],-8
```



6. Definition of a complex linetype *A1* containing an embedded shape *LEG\_SIGN1*:

```
*A1,Example of a custom linetype
A,10,-20,0,[LEG_SIGN1,CS_Gost2304.shx,S=5,R=180,X=-5.5,Y=2.5]
```



7. Definition of a complex linetype *Dashed 14-4* containing embedded shapes *ARROWFILL*, *CIRCLEFILL\_IN* and *CIRCLEFILL\_OUT*:

```
*Dashed 14-4,Dashed line. under linear object <|---O---|>
A,0.01,0,[ARROWFILL,styles.shx,S=0.1,R=180,X=0.7],7,0,[CIRCLEFILL_IN,styles.shx,
S=0.1],0,[CIRCLEFILL_OUT,styles.shx,S=0.1],7,0,[ARROWFILL,styles.shx,S=0.1,X=-
0.7],-4
```



## Managing the Transparency of Objects

Objects in nanoCAD have transparency properties. The transparency is used to reduce the visibility of objects or drawing fragments on the screen to increase the readability of the drawing.

The **Transparency** parameter is displayed in the **Properties** panel (**General** section) when one or several objects are selected and can have values from 0 to 100:

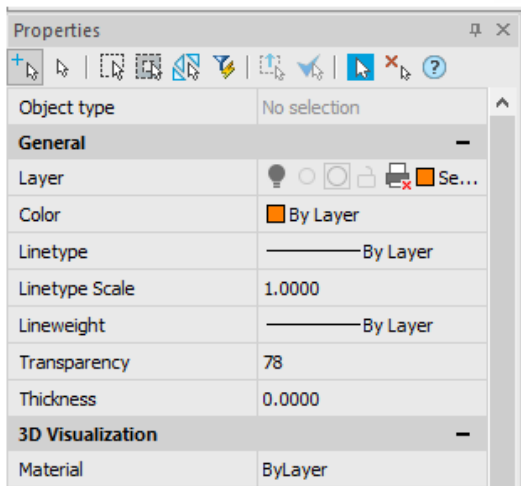

If a value is 100, the selected object becomes invisible. Totally opaque objects have values of 0. The transparency of objects is not shown when printing or previewing the document.

### To set the transparency for an object:

1. Select an object.
2. In the **Transparency** field of the **General** section in the **Properties** bar, specify the required value.



# GEOMETRIC OBJECTS

Base elements to create a drawing are graphic primitives – nanoCAD objects, which are whole objects and cannot be separated with the **Explode** command (**Modify** menu).

## Construction and Reference Geometry

### Point

 Ribbon: **Home, Draw – Draw** >  **Point**

 Menu: **Draw – Point** >  **Single Point**

 Toolbar: **Draw** – 

 Hotkeys: **CTRL+ALT+N**















 Command line: **PO, POINT**

The command allows the creation of point objects which can be shown as a common point or a special symbol. Points are used, for example, for measure (the **Divide** and **Measure** commands) and as reference points for object snap. A point is shown as a special symbol because a point object of the default style is hard to see on the screen. A size of Point objects can be specified according to the screen or in absolute units.

The **Point Styles** dialog box (**Format** menu) allows changing of the size of a point object and its style.

**NOTE:** Changing the size and/or style of point objects affect not only new objects, but also created objects.

The system variable - **PDMODE** controls shape and display of Point object on the screen. Special symbols and their values to display point in the screen:

.	+	+	+	
<b>0</b>	<b>1</b>	<b>2</b>	<b>3</b>	<b>4</b>
				
<b>32</b>	<b>33</b>	<b>34</b>	<b>35</b>	<b>36</b>
				
<b>64</b>	<b>65</b>	<b>66</b>	<b>67</b>	<b>68</b>
				
<b>96</b>	<b>97</b>	<b>98</b>	<b>99</b>	<b>100</b>

When a value of **PDMODE=1** point is invisible on the screen.

System variable **PDSIZE** controls a size of special symbols (for values of **PDMODE**, different from **0** and **1**).

Default value of **PDSIZE=0** specifies the size of symbols, which equals 5% of graphic area height.

The values of **PDSIZE>0** specify absolute value of point display.

The values of **PDSIZE<0** specify point size in percentage of graphic area height.

**Command prompts:**

Specify point: Specify the point coordinates or click on the drawing.

Specify point: Specify the next point or press **ESC** to finish the command.

### Size and Style of Points

 Ribbon: **Draw – Draw >  Points Type**

 Menu: **Format –  Points Styles...**

 Command line: **DDPTYPE**

The **Point Style** dialog box is used to display and change the current style and size of a point. The current display style of the point is highlighted. Click on any symbol to change display style.

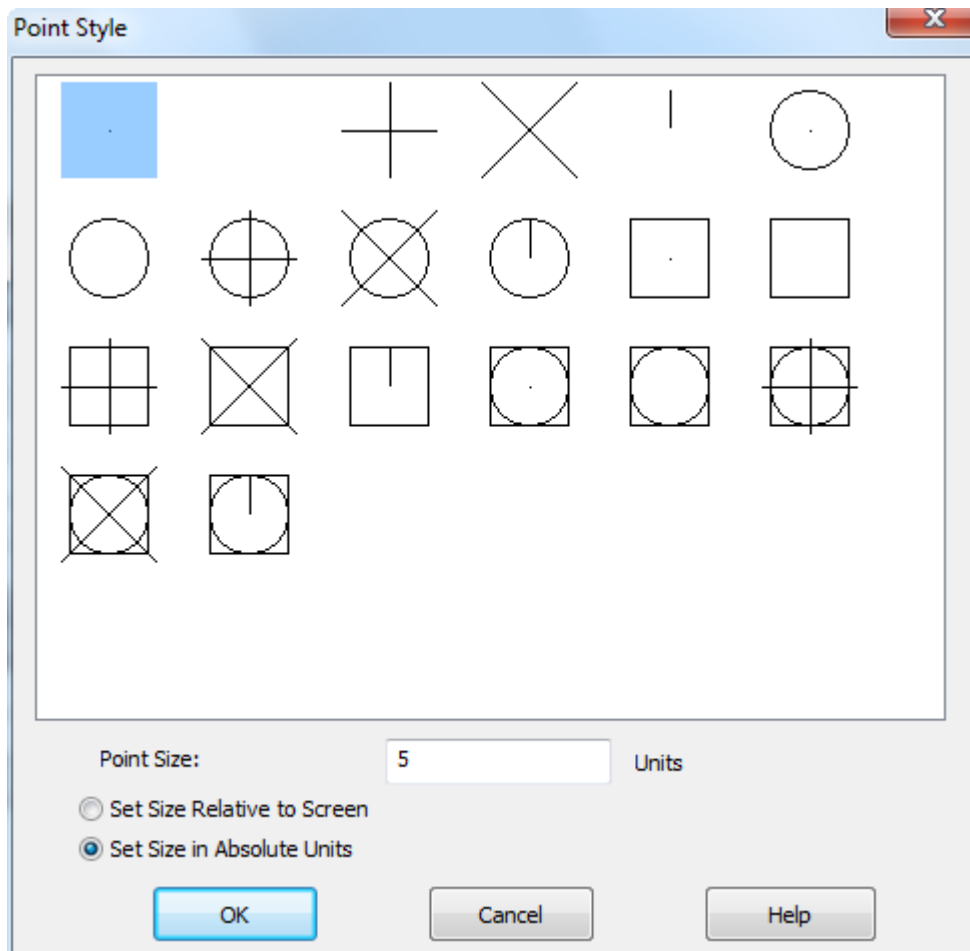

**Parameters:**

<b>Point Size:</b>	Specifies point symbol size. Entered value can specify a size in percentage of screen size or in absolute document units.
<b>Set Size Relative to Screen</b>	Shows point symbol size as a percentage of the screen size (the point size is not changed if the screen is zoomed).
<b>Set Size in Absolute units</b>	The point symbol size is changed if the screen is zoomed (increases or decreases).

*To change the current size and style of a point:*

1. Select the style.
2. Enter the point size in the **Point Size** dialog.
3. Turn the required display size of point symbol on.

## Infinite Lines

Lines, infinite in one or both directions, are called rays and construction lines. These lines can be used as auxiliary lines to create objects. It is recommended to create auxiliary on a separate layer, which can be frozen or made unprintable. Auxiliary lines can be edited; copied, replaced, and rotated.

### Ray



Ribbon: **Home, Draw – Draw >**  **Ray**



Menu: **Draw –**  **Ray**



Toolbar: **Draw –** 



Command line: **RAY**

This command creates a ray – starting in a point and a semi-infinite construction line. The direction of ray is specified by the second point. The command prompt Specify through point: repeats to create several rays. Origin point is the same for all created rays.

#### Command prompts:

Specify start point:	Specify start point.
Specify through point:	Specify second point.
Specify through point:	Specify second point of the next ray or press <b>ENTER</b> to finish the command.

Attention: If in response to prompt to enter the first point of line you press **ENTER** or **SPACE**, the line will be built starting from the endpoint of the last created line, polyline or arc. If arc or polyline arc segment was the last created object, the line is built tangent to arc or arc segment.

## Construction Line



Ribbon: **Home, Draw – Draw >**  **Construction line**



Menu: **Draw –**  **Construction Line**



Toolbar: **Draw –** 



Command line: **XL, XLINE**

This command creates an infinite construction line. The direction of construction line is specified by the second point (origin point is the same for all created lines). The command prompt **Specify through point:** repeats to create several lines.

### Command options:

Hor Creation of an infinite line through the specified point and parallel X axis.

Ver Creation of an infinite line through the specified point and parallel Y axis.

Ang Creation of an infinite line through the specified point with specified angle to X-axis or selected linear object.

### Command prompts:

Enter angle of xline (0) or [Reference]:

### Options:

Angle - Enter angle value

Reference - select linear object. Angle will be calculated related to this object counterclockwise.

Bisect Creation of an infinite bisector line through vertex of an angle.

Offset Creation of an infinite line parallel selected object with specified offset.

### Command prompts:

Specify offset distance [Through/]

### Options:

Offset distance – distance between xline and selected object

Through – drawing xline through specified point and parallel selected linear object.

### Command prompts for drawing xline through point:

Specify start point or [Hor/Ver/Ang/Bisect/Offset/]:

Specify start point.

Specify through point:

Specify second point.

Specify through point:

Specify next point or press **ESC** to finish the command.

### Command prompts for drawing xline parallel axis:

Specify start point or [Hor/Ver/Ang/Bisect/Offset/]:

Select Hor or Ver.

Specify through point:

Specify point.

Specify through point:

Specify next point or press **ESC** to finish the

command.

### **Command prompts for drawing xline with specified angle:**

Specify start point or  
[Hor/Ver/Ang/Bisect/Offset/]:  
Enter angle of xline (0) or  
[Reference]:  
Specify through point:

If you selected Reference option:  
Select a line object or [?/]:  
Enter angle of xline (0) or  
[Reference]:  
Specify through point:

Select Ang.

Enter angle value, press **ENTER**

Specify point.

Select line.

Enter angle value, press **ENTER**  
Specify point.

### **Command prompts for drawing bisector xline:**

Specify start point or  
[Hor/Ver/Ang/Bisect/Offset/]:  
Specify angle vertex point:  
Specify angle start point:  
Specify angle end point:

Select Bisect.

Specify angle vertex point.

Specify angle start point.

Specify angle end point, press **ENTER**.

### **Command prompts for xline parallel linear object:**

Specify start point or  
[Hor/Ver/Ang/Bisect/Offset/]:

Specify offset distance [Through/]  
<Through>

Select a line object or [?/]:

Specify side to offset:

If Through option is selected:  
Select a line object or [?/]:  
Specify through point:

Select Offset.

Specify offset distance for xline.

Select line.

Specify side to offset.

Select line.



Specify point for xline, press **ENTER**.

## **Linear Objects**

### **Line by Two Points**



Ribbon: **Home, Draw – Draw** >  **Line**

 Menu: **Draw** –  **Two points**

 Toolbar: **Draw** – 

 Hotkeys: **CTRL+ALT+L**

 Command line: **L, LINE**

The two point segment is one of the base primitives and is often used for drawing. Segments can be drawn separately and as a set of several segments, merged into zigzag lines. Each segment closed or unclosed line is a separate segment, which is edited separately.

### Command options:

Undo Deletes the last created segment of a created set of segments in an inverse order.

Close Creates the segment, connecting the last point of the last segment with the start point of the first segment. This option is available after the creation of the second segment.



### Command prompts:

Specify first point:	Specify point <b>1</b> .
Specify next point:	Specify point <b>2</b> .
Specify next point [ <u>Undo</u> ]:	Specify next point or select <u>Undo</u> to cancel previous action.
Specify next point [ <u>Undo/Close</u> ]:	Specify next point or press <b>ENTER</b> to finish the command.

Please, note: If you press **ENTER** or **SPACEBAR**, when prompted to enter the first point of a line, the line will start from the end point of the last line, polyline, or arc created. If the last created object was an arc or arc segment of a polyline, the segment is constructed tangent to the arc or arc segment.

## Polyline

 Ribbon: **Home, Draw – Draw >**  **Polyline**

 Menu: **Draw** –  **Polyline**

 Toolbar: **Draw** – 

 Hotkeys: **CTRL+ALT+P**

 Command line: **PL, PLINE, SIMPLEPOLYLINE**

A polyline can contain linear and arc segments and their combinations. It is a graphic primitive. Arc segments of a polyline are created by two points, or by angle, center and tangent or arc radius. When creating arc segments by two points, each next segment is tangent to a previous.

Polylines can have different width, which is specified by Width, Halfwidth. Every segment of polyline can have its width value, and it can expand and contract, if widths in a start and end points are different. Start and end points of segments with widths lay on an axis line.

Polylines can be created not only with the **PLINE** command but also with the **RECTANGLE** (by two points), **FRAME** (by three points), **POLYGON BOUNDARY**, and **REVLOUD**.

Created polyline can be edited with the **PEDIT** command and with ordinary and multipurpose grips. The **Explode** command (from the **Modify** menu) transforms a polyline into separate segments and arcs.

#### *Command options of linear segments:*

<u>Arc</u>	Arc segment mode.
<u>Close</u>	Closes a polyline by linear segment. The option is available when the second point is specified. When the second point is specified the option finishes the command and creates a polyline of one segment.
<u>Halfwidth</u>	Halfwidth (distance from axis line to any of ends) of polyline. When initial halfwidth is specified of polyline segment, this value becomes default value for end halfwidth of a segment. Value of end halfwidth of a segment is the same for next polyline segments, until this value is changed.
<u>Length</u>	Length of segment, created as continuation of the previous segment and in the same direction. For previous arc segment a new line segment is created tangent.
<u>Undo</u>	Deletes the last created segment.
<u>Width</u>	Width of following line segment. When initial width is specified of polyline segment, this value becomes default value for end width of a segment. Value of end width of a segment is the same for next polyline segments, until this value is changed.

#### *Command options of arc segments:*

<u>Angle</u>	Center angle of arc segment starting from start arc point (positive value of angle – arc is created counterclockwise; negative value – arc is created clockwise). When <u>Angle</u> option is selected, the command prompt is shown in the command line after specifying the center angle: Specify endpoint of arc or [ <u>Center/Radius</u> ]: <b>Options:</b> <u>Center</u> - Specifies center of arc segment. <u>Radius</u> - Specifies radius of arc segment.
<u>Center</u>	Center of arc segment. When <u>Center</u> option is selected, the command prompt is shown in the command line after specifying the center of arc: Specify endpoint of arc or [ <u>Angle/Length</u> ]: <b>Options:</b> <u>Angle</u> - Specifies center angle of arc segment from start point. <u>Length</u> - Specifies a length of chord of arc segment. If a previous segment is arc, a next segment is created tangent to it.

- Close Closes a polyline with an arc segment.
- Direction Direction of tangent in start point of arc segment.
- Halfwidth Halfwidth (distance from axis line to any of ends) of polyline segment.  
When initial halfwidth is specified of polyline segment, this value becomes default value for end halfwidth of a segment. Value of end halfwidth of a segment is the same for next polyline segments, until this value is changed.
- Line Linear segment mode.
- Radius Radius of arc segment.  
When Radius option is selected, the command prompt is shown in the command line after specifying the arc radius:  
Specify endpoint of arc or [Angle]:  
**Option:**  
Angle - Specifies center angle of arc segment.
- Second pt Second point of arc in three point creation.
- Undo Deletes the last added arc segment.
- Width Width of following arc segments.  
When initial width is specified of polyline segment, this value becomes default value for end width of a segment. Value of end width of a segment is the same for next polyline segments, until this value is changed.

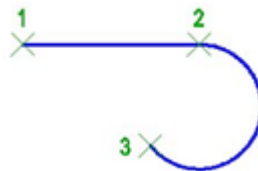

### Command prompts:

- |   |  |
|---|--|
| Specify start point:  | Specify point 1.   |
| Specify next point or [ <u>Arc</u> / <u>Halfwidth</u> / <u>Length</u> / <u>Undo</u> / <u>Width</u> ]:   | Specify point 2.   |
| Specify next point or [ <u>Arc</u> / <u>Close</u> / <u>Halfwidth</u> / <u>Length</u> / <u>Undo</u> / <u>Width</u> ]:  | Select <u>Arc</u> to create an arc segment.                      |
| Specify endpoint of arc or [ <u>Angle</u> / <u>Center</u> / <u>Close</u> / <u>Direction</u> / <u>Halfwidth</u> / <u>Line</u> / <u>Radius</u> / <u>Second pt</u> / <u>Undo</u> / <u>Width</u> ]: | Specify endpoint 3 of arc. Press <b>ENTER</b> to finish command. |

## 3D Polyline



Ribbon: **Home, Draw – Draw >**  **3D Polyline**



Menu: **Draw –**  **3D polyline**





Command line: **3DPOLY**

3D polyline consists of connected straight line segments. Each vertex of 3D polyline can have different heights (Z-direction coordinate). In contrast to a polyline, when drawing 3D polyline, the functions of constructing arc segments and changing the line width are not supported.

### Command options

- Undo                      Deletes the last segment created.
- Close                      Closes the 3D polyline by a line segment.  
The option is available when the third point is specified.

### Command prompts:





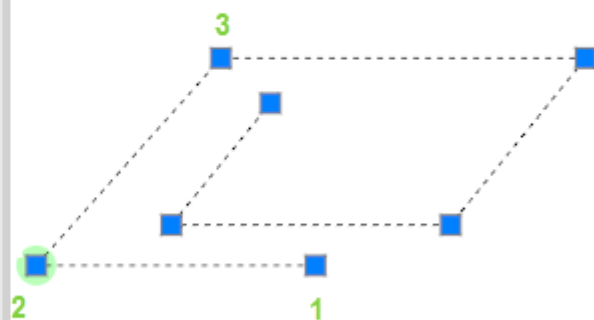
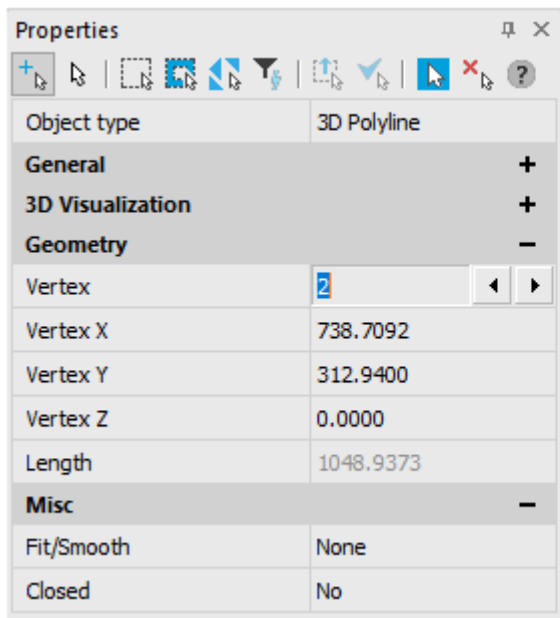

- |                                      |   |
|--------------------------------------|---|
| Specify the point:                   | Assign point 1.   |
| Next point or [ <u>Undo</u> ]:       | Assign point 2.   |
| Next point or [ <u>Undo</u> ]:       | Assign point 3  |
| Next point or [ <u>Close/Undo</u> ]: | After entering the last point, press <b>ENTER</b> to close the command. |

Created 3D polylines can be edited by **PEDIT** command, as well as with help of [custom](#) and [multifunctional grips](#). Command **Split** converts a polyline into separate segments or arcs.

After constructing 3D polyline, the **Vertex** field in the **Properties** window becomes available; there it is possible to select a particular vertex of 3D polyline (in a graphic area it is highlighted) and set the value of its Z-direction coordinate.



## Multiline

-  Ribbon: **Home, Draw – Draw >**  **MLine**
-  Menu: **Draw –**  **Multiline**
-  Toolbar: **Draw –** 



Command line: **MLINE**

Multiline contains parallel lines (items). You can select style, scale and justification.

By default STANDARD style is used, which consists of two elements. To assign another style, it should be created in advance.

Justification defines which side or center line will be used.

The scale value determines the total width of the multiline in current units. The scale factor is determined based on the width specified in the multiline style definition. For example, with a scale of 2, the multiline is twice as wide as specified in the style description.

### Command options:

#### Justification

Determines how the multiline is drawn between the points you specify.

#### Options:

Top - Draws the multiline below the cursor, so that the line with the most positive offset is at the specified points.

Zero - Draws the multiline with its origin centered at the cursor, so that the MLSTYLE Element Properties offset of 0.0 is at the specified points.

Bottom - Draws the multiline above the cursor, so that the line with the most negative offset is at the specified points.

#### Scale

Controls the overall width of the multiline. The scale factor is based on the width established in the multiline style definition.

#### sTyle

Selects the multiline style.

#### Options:

? - list of available styles.

#### Undo

Cancels last entered point.

#### Close

Closes the multiline by joining the last segments with the first segments.

### Command prompts:

Specify next point or  
[Justification/Scale/sTyle]:

Specify first point.

Specify next point or [Undo]:

Specify second point.

Specify next point or [Undo/Close]:

Specify next points.

Press **ENTER** to finish the command.

## Multiline Styles



Ribbon: **Draw – Draw** >  **MultiLine Style**



Menu: **Format** –  **Mline Styles**





Command line: **MLSTYLE**

In **Multiline Styles** dialog you can create, edit, save and load styles.

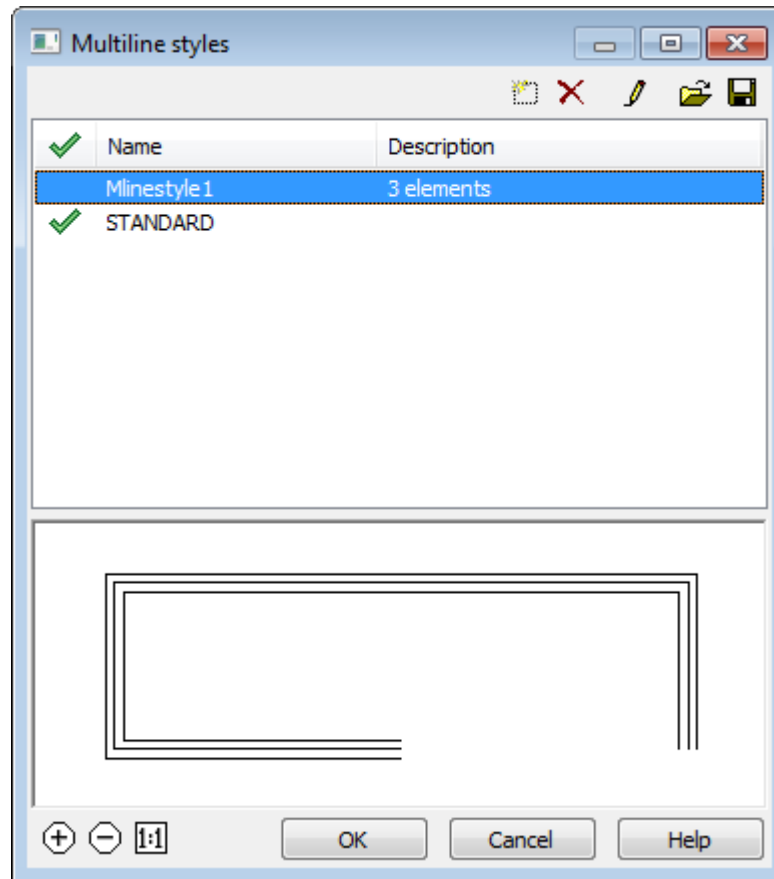
Multiline style defines number of elements and their properties. To create multiline style you should create items and define their properties.



In the bottom part of the dialog there are preview area and buttons to zoom in and zoom out. Also, you can use mouse wheel to zoom:

-  Zoom in;
-  Zoom out;
-  Zoom 1:1.

#### Options:

**State**

List of available styles loaded to the document.

**Name**





Sets current style.

**Description**

Name of multiline style.

Text description.

#### Buttons

-  **New** Creates new multiline style based on selected.
-  **Delete** Removes selected style from the current document.
-  **Edit** Shows multiline style editor dialog.
-  **Load** Loads multiline styles from file to the current document.
-  **Save** Saves selected styles to \*.mln file.



#### To create multiline style:

Multiline style contains these parameters:

- number of elements and their position;

- offset from center line for each element;
- linetype and color for each element;
- joints for each multiline vertex;
- type of used end caps;
- color for multiline filling.

Elements with positive offsets are placed on the one side from center line, elements with negative offsets - on the other side.

1. Start **Mline Styles** command.
2. In **Multiline Styles** select desired style and click button  **New**. New style with default name *MlineStyleN*, where *N* – ordinal number starting from 1. will appear. All settings will be based on selected style.
3. Click button  **Edit** to start editing created style.

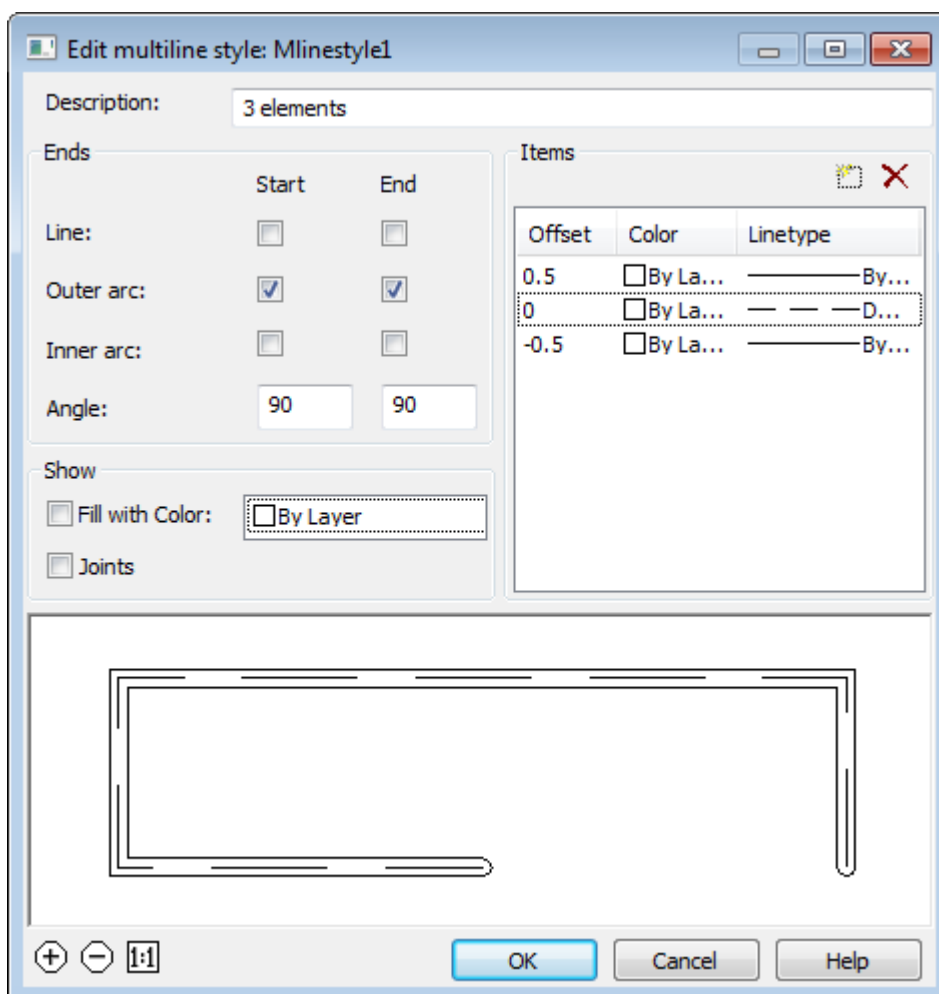

4. Set desired parameters and click **OK**.

*Options:*

*Description*

Text description.

*Ends*

The type of end caps.

**Start**

Sets the type of end caps for start and end of the multiline.

**End**

**Line**

Displays a line segment across each end of the multiline.

**Outer Arc**

Displays an arc between the outermost elements of the multiline.

**Inner Arc**



Displays an arc between pairs of inner elements. If there's an odd number of elements, the center line is unconnected. For example, if there are six elements, inner arcs connect elements 2 and 5 and elements 3 and 4. If there are seven elements, inner arcs connect elements 2 and 6 and elements 3 and 5. Element 4 is left unconnected.

**Angle**

Specifies the angle of the end caps.

*Show*

Controls the background fill of the multiline

**Fill with Color**

Sets the background fill color of the multiline. When you choose **Select Color**, the **Select Color** dialog box is displayed.

**Joints**

Controls the display of the joints at the vertices of each multiline segment.

*Items*

Sets element properties, such as the offset, color, and linetype, of new and existing multiline elements.

**Offset**

Specifies offset from the middle of the multiline. Elements are displayed in descending order of their offsets.

**Color**

Specifies color.

**Linetype**

Specifies linetype for element.



**Add Item**

Adds new element.



**Delete Item**

Removes the selected element.

**Save Multiline Styles**

Multiline Styles can be saved to \*.mln file.

1. In the **Multiline Styles** dialog click  **Save** button.
2. In **Save Multiline Styles** dialog select styles. Click **OK**.

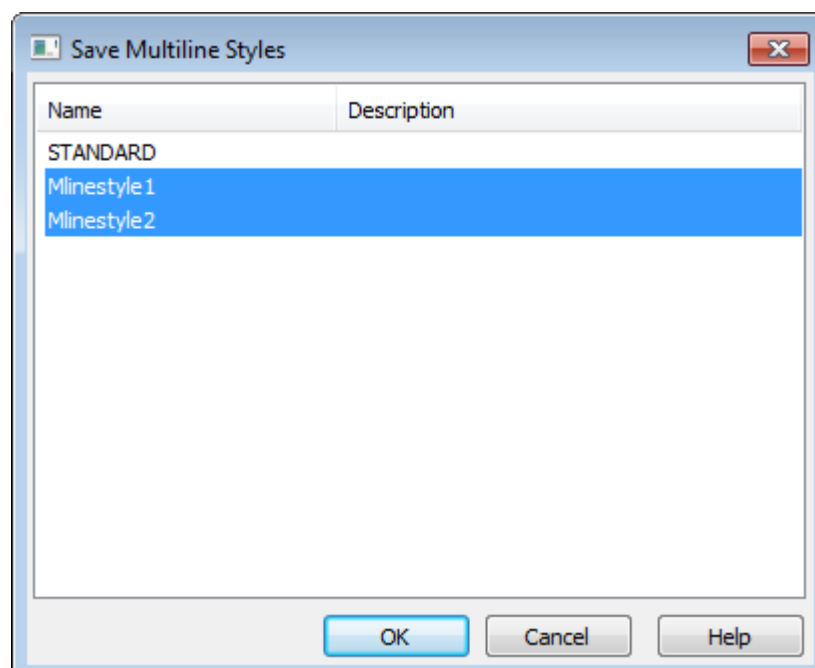

3. Specify the file name and path.

## Load Multiline Styles

1. In the **Multiline Styles** dialog click  **Load** button.
2. Specify the file name and path.
3. In **Load multiline style** dialog select styles to load in the current document. Click **OK**.

## Polygon



Ribbon: **Home, Draw – Draw >**  **Closed Polygon**



Menu: **Draw –**  **Closed Polygon**



Toolbar: **Draw –** 



Command line: **POL, POLYGON**

The command creates polygons with similar sides from closed polylines. A special case of equilateral polygon is a square.

The **Explode** command (from the **Modify** menu) allows transferring a polyline which polygon consists of, into segments.

### Command options:

#### Edge

Creates a polygon by its edge length. Edge length is specified by its endpoints.

#### Inscribed

Creates an inscribed polygon by specifying a radius of circle, where polygon endpoints lie. If you specify a radius by mouse in graphic area (point 2), at the same time a rotation angle of polygon is specified.

#### Circumscribed

Creates a circumscribed polygon by specifying a radius of circle, where middles of polygon's edges lie. If you specify a radius by mouse in graphic area (point 2), at the same time a rotation angle of polygon is specified.

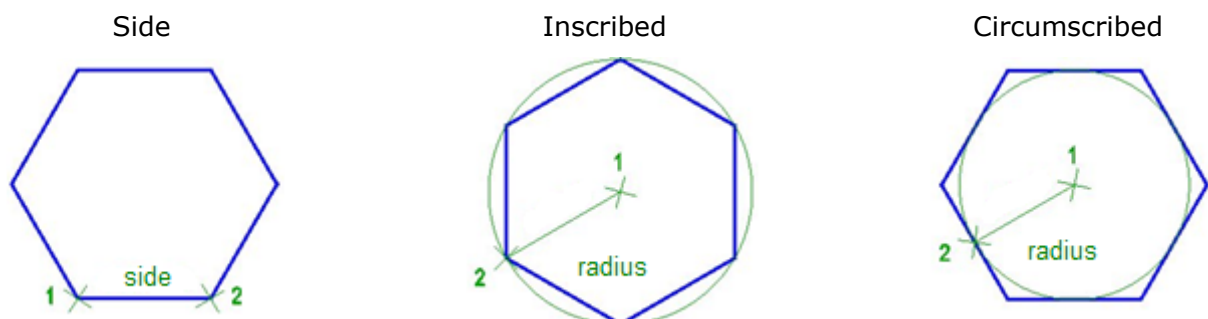

### Command prompts when creating a polygon by side:

Enter number of sides <6>:

Specify center of polygon or [Edge]:

Specify first endpoint of edge:

Enter number of sides for polygon.

Select Edge.

Specify point 1.

Specify second endpoint of edge:

Specify point 2.

**Command prompts when creating a polygon by radius:**

Enter number of sides <6>:

Enter number of polygon's sides.

Specify center of polygon or [Edge]:

Specify center point 1.

Extend <"Inscribed"> or [Inscribed/Circumscribed]:

Select option.

Specify radius of circle:

Specify radius (point 2).

## Rectangle

Rectangle is a special case of a closed polyline. The **Explode** command transforms polyline which rectangle consists of, into segments.

There are three ways to create a rectangle:

- [by](#) two points;
- [from center](#) (with center in the specified point);
- [by three points](#).

### Rectangle by Two Points



Ribbon: **Home, Draw – Draw >**  **Rectangle by Two Points**



Menu: **Draw – Rectangle by >**  **Two points**



Toolbar: **Draw –** 



Hotkeys: **CTRL+ALT+R**



Command line: **REC,RECT,RECTANG,RECTANGLE**

The command allows creating a rectangle (flat closed rectangular polyline) from two opposite points.

Parameters of rectangle (length, width, area, rotation angle) can be specified and types of angles (right angle, with chamfer or rounded by radius) can be edited with this command.

**Command options when a first corner point is specified:**

Center Switches to the mode of drawing a rectangle from center.

Chamfer Chamfer sizes for rectangle's corner.

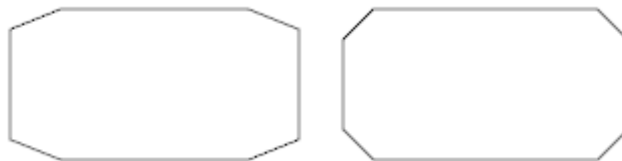

Elevation Sets the elevation (Z-axis) for the rectangle.

Since the rectangle is a flat figure, the Z-coordinates of its vertices in the UCS are determined by the **Elevation** parameter.

Geometry	
Vertex	1
Vertex X	897.657
Vertex Y	283.8719
Segment width start	0
Segment width end	0
Global width	0
Elevation	30
Length	933.7988
Area	52341.3534

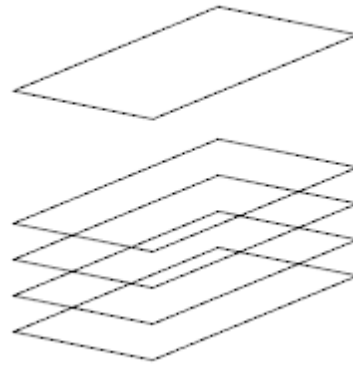

### Fillet

Sets the current radius for fillet of rectangle's corners.



### Thickness

Current three-dimensional height.

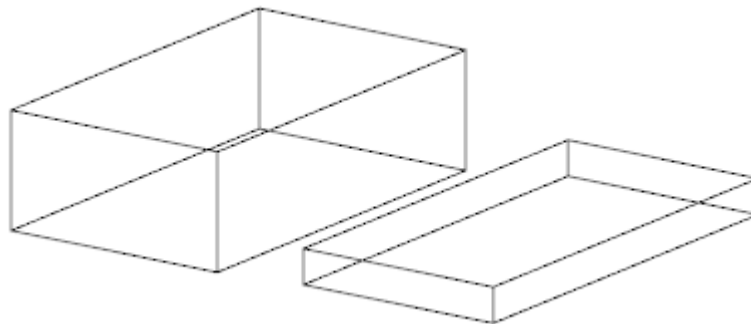

### Width

Width of polyline to create a



rectangle.

### **Command options when a second corner point is specified:**

#### Area

Area of rectangle when it is created by area and length or by area and width  
After a value of area is specified a prompt is shown in a command line:

Calculate rectangle dimensions based on [Length/Width]<Length>:

#### **Options:**

Length - Specifies length of rectangle.

Width - Specifies width of rectangle.

#### Dimension

Height and length of rectangle.

#### Rotation

Rotation angle of rectangle by entering its value in the command line or specifying on the screen. The Pick Points option allows specifying a rotation



angle by specifying two points on the screen.

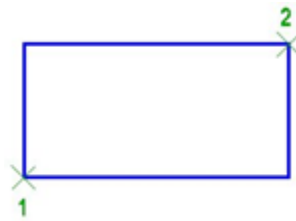

### Command prompts:

Specify first corner point or  
[Chamfer/Elevation/Fillet/Thickness/Width]:

Specify first corner (point 1).

Specify other corner point or  
[Area/Dimensions/Rotation]:

Specify second corner (point 2).

### Isorectangle

Creating a rectangle in the current isoplane.

In the command of creating a rectangle by two point, the **Isorectangle** option is available only when the *isometric mode is enabled*:  button in the status bar or the **Isometric** snap type set in the **Grid snap** of the drafting settings.

1. Enable the isometry mode.
2. Select the command to create a rectangle by two points.
3. Upon the command line prompt: Specify first corner point or [Chamfer/Elevation/Fillet/Thickness/Width/Isorectangle]: - select **Isorectangle**.

### Command prompts

Specify first corner point or  
[Dimensions]:

Specify the first corner or select the **Dimensions** option to create a rectangle by length and width.

Speify other corner point:

Specify the second corner.

## Creating a Rectangle from Center



Ribbon: **Home, Draw – Draw** >  **Rectangle from Center**



Menu: **Draw – Rectangle by** >  **from Center**



Toolbar: **Draw** – 



Command line: **RECTCENTER**

The command allows you to draw a rectangle (a flat closed rectangular polyline) with a center at a specified point.

When constructing a rectangle using this command, you can set the rectangle parameters (length, width, area, rotation angle), as well as control the type of its corners (square corners, chamfered or rounded with a radius).

**Command options available when specifying the center:**

- cOrner Switches to the mode of drawing a rectangle by two points.
- Chamfer Sets the chamfer size for the rectangle's corners.

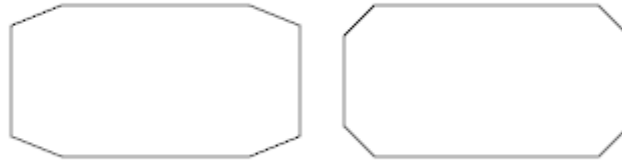

- Elevation Sets the elevation (Z-axis) for the rectangle. Since the rectangle is a flat figure, the Z-coordinates of its vertices in the UCS are determined by the **Elevation** parameter.

Geometry	
Vertex	1
Vertex X	897.657
Vertex Y	283.8719
Segment width start	0
Segment width end	0
Global width	0
Elevation	30
Length	933.7988
Area	52341.3534

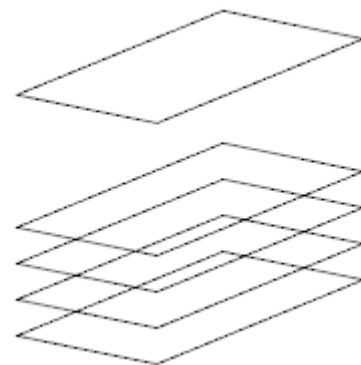

- Fillet Sets the current radius for fillet of rectangle's corners.



- Thickness Specifies the 3D height for the rectangle.

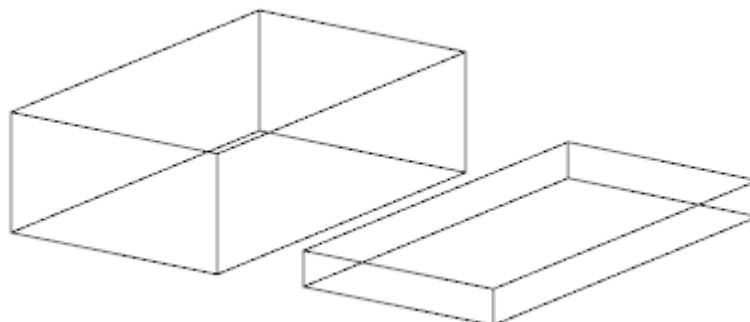

- Width Sets the polyline width for building a rectangle.

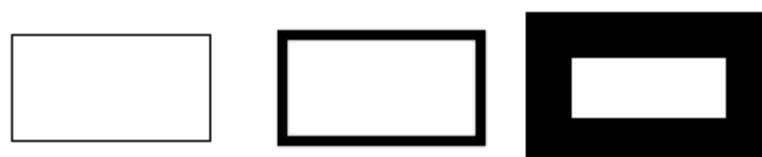

**Command options available when specifying other corner point:**

- Area Specifying the rectangle area when it is created by area and specified

length or by area and specified width.

After setting the area value, the following prompt is displayed in the command line:

Calculate rectangle dimensions based on [Length/Width]:

**Options:**

Length - Specifies the rectangle's length.

Width - Specifies the rectangle's width.

Dimensions Sets values for creating a rectangle by length and width.

Rotation Specifies the rotation angle of the rectangle by entering its value in the command line or by specifying a point on the screen.

The Pick Point option allows you to set the rotation angle by specifying two points on the screen.



**Command prompts:**

Specify rectangle center or [cOrner/Chamfer/Elevation/Fillet/Thickness/Width]:

Specifies the center (point 1).

Specify other corner point or [Area/Dimensions/Rotation]:

Specifies the second corner (point 2).

**Isorectangle**

Creating a rectangle in the current isoplane.

In the command for constructing a rectangle using two points, the Isorectangle option is available only when the isometric mode is enabled: the button in the status bar or the snap type is set to Isometric in the Snap snap setting

Creating a rectangle in the current isoplane.

In the command for creating a rectangle using two points, the **Isorectangle** option is available only when the *isometric mode is enabled*: the  **ISO** button in the status bar or the snap type is set to **Isometric** in the **Snap** setting.

1. Enable the isometric mode.
2. Select the command for creating a rectangle by two points.
3. At the prompt of the command line: Specify first corner point or [center/Chamfer/Elevation/Fillet/Thickness/Width/Isorectangle] : - select Isorectangle.

**Command prompts**

Specify first corner point or [Dimensions]:

Specify the first corner or select the Dimensions option to create a rectangle by length and width.



Specify other corner point:

Specify the second point.

## Rectangle by Three Points

 Ribbon: **Home, Draw – Draw >**  **Rectangle by 3 points**

 Menu: **Draw – Rectangle by >**  **Three points**

 Toolbar: **Draw –** 

 Command line: **FRAME**

The command creates a rectangle (flat closed rectangular **polyline**) by corner and two sides.

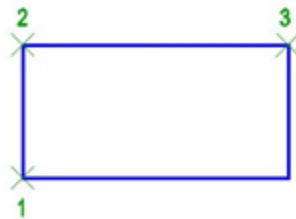

### Command prompts:

Specify first point of rectangle:	Specify rectangle's corner (point 1).
Specify second point of rectangle:	Specify length of first side (point 2).
Specify third point of rectangle:	Specify length of second side (point 3).

## Curved Objects

### Arc

An arc can be created with different methods. . There are 13 methods for creating an arc available in nanoCAD.









#### Command options for creating an arc:

<u>Center</u>	Arc center.
<u>Angle</u>	Arc angle.
<u>chordLength</u>	Chord length.
<u>End</u>	End point of arc.
<u>Direction</u>	Direction of tangent from the start point of the arc.
<u>Radius</u>	Radius.

To change the direction for creating an arc, use the prompt in the command line:

Arc direction: counterclockwise (hold Ctrl to switch direction).

## Arc by Three Points



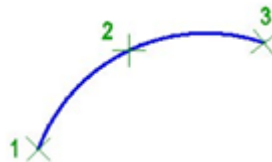



-  Ribbon: **Home, Draw – Draw – Arc >**  **3-Point**
-  Menu: **Draw – Arc >**  **3 points**
-  Toolbar: **Draw –** 
-  Hotkeys: **CTRL+ALT+A**
-  Command line: **A, ARC**



### Command prompts:

- |  |                         |
|--|-------------------------|
| Specify start point of arc or [Center]:      | Specify start point 1.  |
| Specify second point of arc or [Center/End]: | Specify second point 2. |
| Specify end point of arc:                    | Specify end point 3.    |

## Arc by Center, Start and End

-  Ribbon: **Home, Draw – Draw – Arc >**  **Center, Start, End**
-  Menu: **Draw – Arc >**  **3 points**
-  Toolbar: **Draw –** 
-  Command line: **ARCBYCENTERSTARTEND**

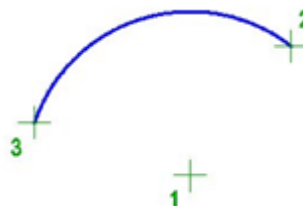

### Command prompts:

- |                              |                               |
|------------------------------|-------------------------------|
| Specify center point of arc: | Specify arc center (point 1). |
| Specify start point of arc:  | Specify start point 2.        |

Specify end point of arc:

Specify end point 3.

## Arc by Continue

Creates an arc tangent to the last created arc, line, or polyline object, 2D polyline or 3D polyline. The end point of previous object will be the arc start point.

Attention: For quick creation of such arcs you can also press **ENTER** or **SPACE** in response to prompt "Specify start point of arc" in the arc creation command



Ribbon: **Home, Draw – Draw – Arc >**  **Continue**



Menu: **Draw – Arc >**  **Continue**



Toolbar: **Draw –** 



Command line: **ARCBYCONTINUE**

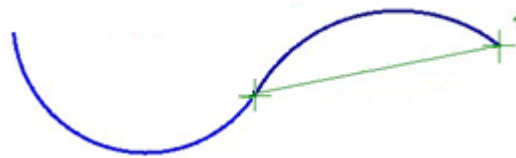

### Command prompts:

Specify end point of arc:

Specify end point 1.

## Arc by Start, Center and End



Ribbon: **Home, Draw – Draw – Arc >**  **Start, Center, End**



Menu: **Draw – Arc >**  **Start, Center, End**



Toolbar: **Draw –** 



Command line: **ARCBYSTARTCENTEREND**

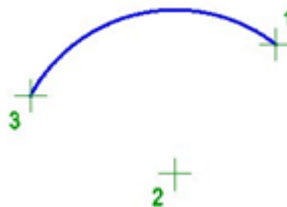

### Command prompts:

Specify start point of arc:

Specify start point 1.





Specify center point of arc:

Specify arc center (point 2).

Specify end point of arc:

Specify end point 3.

## Arc by Start, Center and Angle



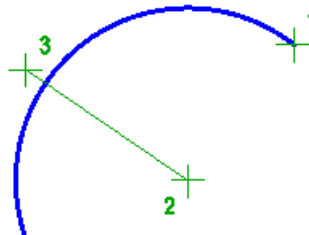



-  Ribbon: **Home, Draw – Draw – Arc** >  **Start, Center, Angle**
-  Menu: **Draw – Arc** >  **Start, Center, Angle**
-  Toolbar: **Draw** – 
-  Command line: **ARCBYSTARTCENTERANGLE**



### Command prompts:

- |                              |                                 |
|------------------------------|---------------------------------|
| Specify start point of arc:  | Specify start point 1.          |
| Specify center point of arc: | Specify arc center (point 2).   |
| Specify included angle:      | Specify center angle (point 3). |

## Arc by Start, Center and Chord Length

-  Ribbon: **Home, Draw – Draw – Arc** >  **Start, Center, Length**
-  Menu: **Draw – Arc** >  **Start, Center, Length**
-  Toolbar: **Draw** – 
-  Command line: **ARCBYSTARTCENTERLENGTH**

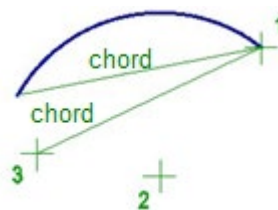



### Command prompts:

- |                              |                                 |
|------------------------------|---------------------------------|
| Specify start point of arc:  | Specify start point 1.          |
| Specify center point of arc: | Specify arc center (point 2).   |
| Specify length of chord:     | Specify chord length (point 3). |

## Arc by Start, End and Angle

-  Ribbon: **Home, Draw – Draw – Arc** >  **Start, End, Angle**

 Menu: **Draw – Arc** >  **Start, End, Angle**

 Toolbar: **Draw** – 

 Command line: **ARCBYSTARTENDANGLE**

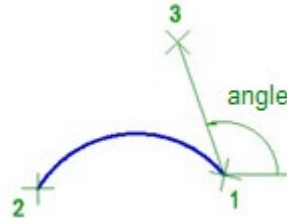

### **Command prompts:**

Specify start point of arc:

Specify start point 1.

Specify end point of arc:



Specify end point 2.

Specify included angle:

Specify center angle (point 3).

## **Arc by Start, End and Direction**

 Ribbon: **Home, Draw – Draw – Arc** >  **Start, End, Direction**

 Menu: **Draw – Arc** >  **Start, End, Direction**

 Toolbar: **Draw** – 

 Command line: **ARCBYSTARTENDDIRECTION**

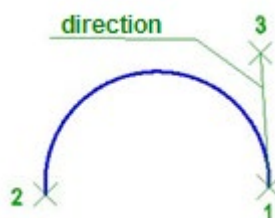

### **Command prompts:**

Specify start point of arc:

Specify start point 1.

Specify end point of arc:



Specify end point 2.

Specify tangent direction for the start point of arc:

Specify tangent direction (point 3).

## **Arc by Start, End and Radius**

 Ribbon: **Home, Draw – Draw – Arc** >  **Start, End, Radius**

 Menu: **Draw – Arc** >  **Start, End, Radius**

 Toolbar: **Draw** – 



 Command line: **ARCBYSTARTENDRADIUS**

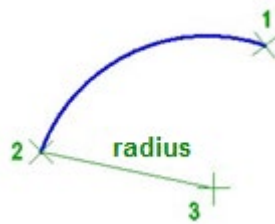

**Command prompts:**

Specify start point of arc:	Specify start point 1.
Specify end point of arc:	Specify end point 2.
Specify radius of arc:	Specify arc radius (point 3).

### Arc by Start, Radius and Tangent

 Ribbon: **Home, Draw – Draw – Arc >**  **Start, Radius, Tangent**

 Menu: **Draw – Arc by >**  **Start, Radius, Tangent**

 Toolbar: **Draw –** 

 Command line: **ARCBYSTARTRADIUSTANGENT**

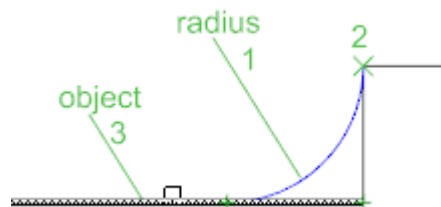



**Command Prompts:**

Specify radius of arc:	Specify the radius value (1).
Specify start point of arc:	Specify the start point (2).
specify tangent object or [?]:	Specify the object to be tangent (3).

### Arc by Center, Start and Chord Length

 Ribbon: **Home, Draw – Draw – Arc >**  **Center, Start, Length**

 Menu: **Draw – Arc >**  **Center, Start, Length**

 Toolbar: **Draw –** 



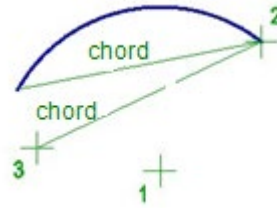



 Command line: **ARCBYCENTERSTARTLENGTH**



**Command prompts:**

Specify center point of arc:	Specify arc center (point 1).
Specify start point of arc:	Specify start point 2.
Specify length of chord:	Specify chord length (point 3).

### Arc by Center, Start and Angle



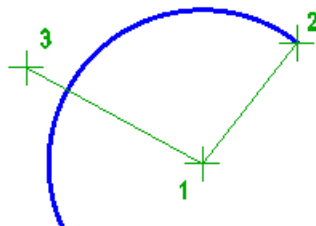



-  Ribbon: **Home, Draw – Draw – Arc >**  **Center, Start, Angle**
-  Menu: **Draw – Arc >**  **Center, Start, Angle**
-  Toolbar: **Draw –** 
-  Command line: **ARC2, ARCBYCENTERSTARTANGLE**



**Command prompts:**

Specify center point of arc:	Specify arc center (point 1).
Specify start point of arc:	Specify start point 2.
Specify included angle:	Specify angle (point 3).

### Arc by Center, Angles and Radius

-  Ribbon: **Home, Draw – Draw – Arc >**  **Center, Angles, Radius**
-  Menu: **Draw – Arc >**  **Center, Angles, Radius**
-  Toolbar: **Draw –** 
-  Command line: **ARC3, ARCBYCENTERANGLESRADIUS**

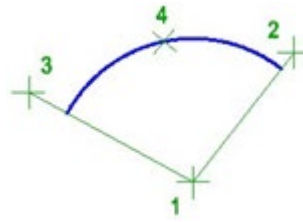









**Command prompts:**

- Specify center point of arc: Specify center of arc (point 1).
- Specify start angle of arc: Specify start angle (point 2).
- Specify end angle of arc: Specify end angle (point 3).
- Specify radius of arc: Specify radius (point 4).

## Circle

### Circle by Center and Radius

-  Ribbon: **Home, Draw – Draw – Circle >**  **Center, Radius**
-  Menu: **Draw – Circle >**  **Center, radius**
-  Toolbar: **Draw –** 
-  Hotkeys: **CTRL+ALT+C**
-  Command line: **C, CIRCLE**

**Command options:**

- 3P Circle by three points.
- 2P Circle by diameter.
- TTR Circle by two tangents and radius.
- 3T Circle by three tangents.
- Diameter Circle by center and diameter.

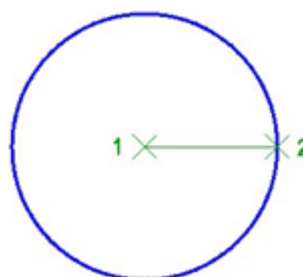

**Command prompts:**

Specify center point of circle or [3P/2P/ITR]:

Specify center (point 1).

Specify radius:

Specify radius of circle (point 2).

## ***Circle by Two Tangents and Radius***



Ribbon: **Home, Draw – Draw – Circle >**  **Tan, Tan, Radius**



Menu: **Draw – Circle >**  **Two Tangents, Radius**



Toolbar: **Draw –** 



Command line: **CIRCLEBYTTR**

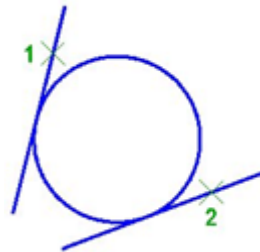

### ***Command prompts:***

Specify a point on first tangent object:

Select a first tangent object (point 1).

Specify a point on second tangent object:

Select a second tangent object (point 2).

Specify radius:

Specify radius of circle.

## ***Circle by Center and Diameter***



Ribbon: **Home, Draw – Draw – Circle >**  **Center, Diameter**



Menu: **Draw – Circle >**  **Center, Diameter**



Toolbar: **Draw –** 



Command line: **CIRCLEBYDIAMETER2**

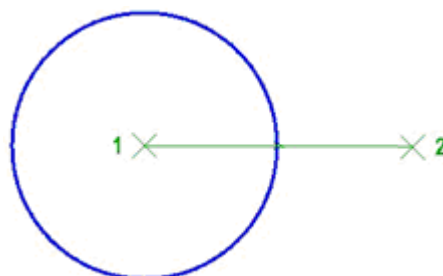

### ***Command prompts:***

Specify center point of circle:

Specify center (point 1).

Specify diameter:

Specify diameter (point 2).

## Circle by Diameter



Ribbon: **Home, Draw – Draw – Circle >**  **2-Point**



Menu: **Draw – Circle >**  **Diameter**



Toolbar: **Draw –** 



Command line: **CIRCLEBYDIAMETER, CIRCLE2**

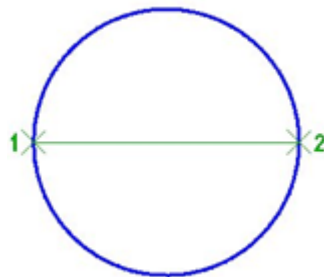

### Command prompts:

Specify first end point for circle's diameter:

Specify first point 1 for circle diameter

Specify second end point for circle's diameter:

Specify end point 2 for circle diameter

## Circle by Three Points



Ribbon: **Home, Draw – Draw – Circle >**  **3-Point**



Menu: **Draw – Circle >**  **3 points**



Toolbar: **Draw –** 



Command line: **CIRCLEBY3POINTS, CIRCLE3**

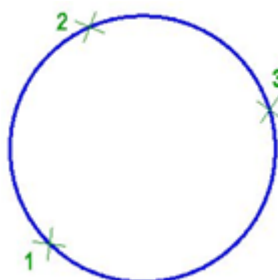

### Command prompts:

Specify first point on circle:

Specify first point.

Specify second point on circle:

Specify second point.

Specify third point on circle:

Specify third point.

## Circle by Three Tangents

Creating a circle tangent to three objects.

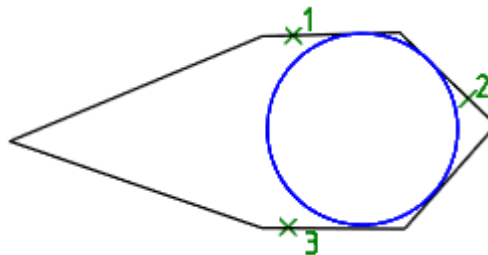

Ribbon: **Home, Draw – Draw – Circle >**  **3 Tangents**



Menu: **Draw – Circle >**  **3 Tangents**



Toolbar: **Draw –** 



Command line: **CIRCLEBYT3CL, T3CL**

### Command prompts:

First tangent:

Specify the first object.

Second tangent:

Specify the second object.

Third tangent:

Specify the third object.

Objects can be specified in any order.

## Donut



Ribbon: **Home – Draw >**  **Donut**



Ribbon: **Draw – Hatches and Fills >**  **Donut**



Menu: **Draw –**  **Donut**



Command line: **DONUT**

The command allows you to create a number of donuts with the same diameter value but different center point.

A donut consists of two arc polylines that are joined end-to-end to create a circular shape. The width of the polylines is determined by the specified inside and outside diameters. If you specify an inside diameter of 0, the donut is a filled circle.

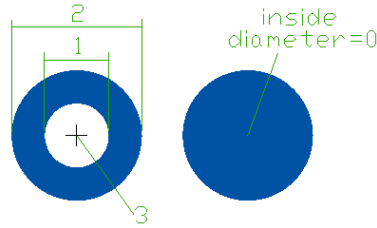

### Command options:

Specify inside diameter of donut <current>:

Specify outside diameter of donut <current>:

Specify center of donut or <exit>:

Specify diameter 1.

Specify diameter 2.

Specify the location of the donut based on its center point (point 3). A donut is drawn at each point specified until you press **ENTER** to end the command.

The command allows you to create any number of donuts having the same diameters, but different centers.

## Spline



Menu: **Draw** –  **Spline**



Toolbar: **Draw** – 



Command line: **SPL, SPLINE**

A spline is a smooth curve passing through a given set of points. Example of spline usage: line breaks of objects.

Spline can be created by two methods:

### Fit points

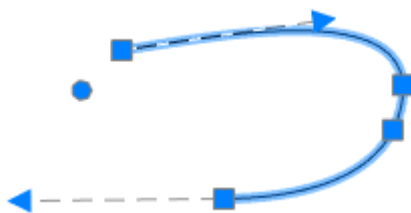

When creating splines using fit points, the resulting curve goes through the specified points and depends on intervals between mathematic knots of curve.

### Control vertices

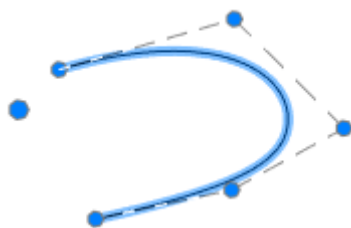

When creating splines using control vertices, temporary lines are displayed between the specified points, they form control polygon that defines the spline form.

### Command options:

<u>Method</u>	Selects the method of creation [Fit/Control]
<u>Object</u>	Converts a polyline, smoothed by the <u>Spline</u> and <u>Smooth</u> commands, to an equivalent spline.
<u>Close</u>	Closes a spline.
<u>Fit tolerance</u>	The maximum distance from a spline curve to any points defining it.
<u>Undo</u>	Successively reverses the specified points. It is impossible to undo the specified start point.

## Creating Splines by Fit Points Method



Ribbon: **Main – Draw** >  **Fit points**



Menu: **Draw – Spline** >  **Fit points**



Toolbar: **Draw** –  **Fit points**



Command line: **SPL, SPLINE – Method** > **Fit**

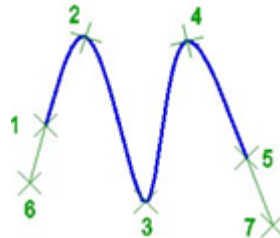

### Command prompts:

Current settings:

Method=Fit

Specify first point or [Method/Object]:

Specify a start point 1.

Specify second point:

Specify second point 2.

Specify next point [Fit tolerance/Undo] <start tangent>

Specify 3, 4, 5 etc. points.

Specify next point or [Close/Fit tolerance/Undo] <start tangent>

Press **ENTER** to finish specifying points.

Specify start tangent:

Specify a tangent 6 for the start spline point.

Specify end tangent:

Specify a tangent 7 for the end spline point.



## Creating Splines by Control Vertices Method



Ribbon: **Main – Draw** >  **Control vertices**



Menu: **Draw – Spline** >  **Control vertices**



Toolbar: **Draw** –  **Control vertices**



Command line: **SPL, SPLINE – Method > Control**

### Command prompts:

Current settings: Method=Cv

Specify first point or  
[Method/Object]:

Specify the spline start point.

Specify second point:

Specify the second point.

Specify next point or [Undo]:

Specify the next point.

Specify next point or  
[Close/Undo]:

Specify all next points. Press **ENTER** to close the command.

## Converting Objects to Spline

Lines, polylines, spline-smoothed polylines, arcs, circles, elliptical arcs can be transformed into a spline.

Specify first point or  
[Method/Object]: **Object**

Select the Object option.

Select objects to convert to  
splines or [?]:

Select objects.

Press **ENTER** to complete the command.

## Ellipse

System variable **PELLIPSE** controls the type of newly created ellipses.

- The variable value **PELLIPSE = 0** creates a true ellipse.
- The variable value **PELLIPSE = 1** creates a 2D polyline representation of ellipse from arc segments.

## Ellipse by Semi-axes



Ribbon: **Home, Draw – Draw** >  **By Semi-axes**



Menu: **Draw – Ellipse By** >  **Semi-axes**



Toolbar: **Draw** – 



Command line: **ELLIPSE1**

The command creates an ellipse by center and radiuses.

### Command options:

Rotation      Relation between ellipse axes by rotation around first axis.

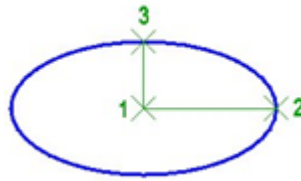

**Command prompts:**

Specify center point for ellipse:	Specify center point for ellipse (point 1).
Specify endpoint of axis:	Specify first radius (point 2).
Specify distance to other axis or <u>[Rotation]</u> :	Specify second radius (point 3).

**Ellipse by Axis and Semi-axis**

 Ribbon: **Home, Draw – Draw >**  **By Axis and Semi-axis**

 Menu: **Draw – Ellipse By >**  **Axis and Semi-axis**

 Toolbar: **Draw –** 

 Command line: **ELLIPSE2, ELLIPSEBYDIAMETER**

The command creates an ellipse by axis and semi-axis.

**Command options:**

Rotation      Relation between ellipse axes by rotation around first axis.

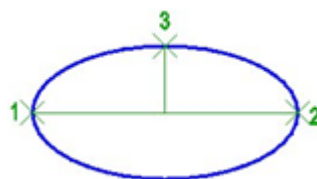

**Command prompts:**

Specify axis endpoint of ellipse:	Specify point 1.
Specify other axis endpoint of ellipse:	Specify diameter of ellipse (point 2).
Specify distance to other axis or <u>[Rotation]</u> :	Specify radius of ellipse (point 3).

## Elliptic Arc

 Ribbon: **Home, Draw – Draw >**  **Elliptical Arc**

 Menu: **Draw – Ellipse By >**  **Elliptic Arc**

 Toolbar: **Draw –** 

 Command line: **ELLIPTICARC**

### Command options:

Center                      Center of elliptic arc.

Rotation                    Relation between ellipse axes by rotation around the first axis

Parameter                Select Parameter when specifying the start and end points of the elliptic arc to create an elliptic arc according to the parameter vector:

$$p(u) = c + a * \cos(u) + b * \sin(u), \text{ where}$$

$c$  – ellipse center;

$a$  – major axis;

$b$  – minor axis.

Inner angle                Inner angle of the elliptic arc; specified relative to the origin angle.

Angle                        Switch to the arc creation mode by specified angles.

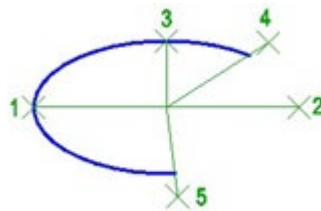

### Command prompts:

Specify axis endpoint of elliptical arc or [Center]:

Specify point 1.

Specify other axis endpoint of elliptical arc:

Specify length of ellipse axis (point 2).

Specify distance to other axis or [Rotation]:

Specify length of another axis (point 3).

Specify start angle or [Parameter]:

Specify start angle (point 4).

Specify end angle or [Parameter/Inner angle]:

Specify end angle (point 5).

## Creation of Ellipses and Elliptic Arcs with One Command



Command line: EL, **ELLIPSE**

Universal command allows you to create ellipses by center, minor and major axes, and create elliptic arcs.

### Command options:

- Arc Switches to the mode of elliptic arc creation.
- Center Center of ellipse.
- Rotation Creates ellipse by rotating a circle about the first axis.

### Command options of the creation of elliptic arc mode:

- Center Center of elliptic arc.
- Rotation Relation between ellipse axes by rotation around the first axis.
- Parameter Select Parameter when specifying the start and end points of the elliptic arc to create an elliptic arc according to the parameter vector:  
 $p(u) = c + a * \cos(u) + b * \sin(u)$ , where  
 $c$  – ellipse center;  
 $a$  – major axis;  
 $b$  – minor axis.
- Inner angle Inner angle of the elliptic arc; specified relative to the origin angle.
- Angle Switch to the arc creation mode by specified angles.

## Creation of Isocircle and Isoarc

Creating circle and arc in the *current isoplane*.

In the commands for creating an ellipse, the **Isocircle** and **Isoarc** options are available only when the *isometric mode is enabled*: the **Isometric** snap type set in the **Grid snap** of the drafting settings.

### Isocircle

1. Enable the isometric mode.
2. Select the command to create an ellipse.
3. Upon the command line prompt: Specify axis endpoint of ellipse or [Arc/Center/Isocircle]: - select **Isocircle**.

### Command prompts

Specify center of isocircle:

Specify center of isocircle.

Specify radius of isocircle or [Diameter]:

Specify the value of semi-axis or select Diameter and specify its value.

### Isoarc

1. Enable the isometric mode.

2. Select the **Elliptical Arc**  Command.

When selecting the **Arc** option in the universal command in response to the command line prompt: Specify axis endpoint of ellipse or [Arc/Center/Isocircle]: - select Arc

### Command prompts

Specify axis endpoint of elliptical arc or [Center/Isoarc]:

Select Isoarc.

Specify center of isocircle:

Specify the center point.

Specify radius of isocircle or [Diameter]:

Specify the value of semi-axis or select Diameter and specify its value.

Specify start angle or [Parameter]:

Specify a start angle.

Specify end angle or [Parameter/Inner angle]:

Specify an end angle.

## Helix



Ribbon: **Home, Draw – Draw >**  **Helix**



Menu: **Draw –**  **Helix**



Command line: **HELIX**

Command creates 2D spiral or 3D spring. Helix is used to create springs, carvings, rounded stairs.

### Options:

Base radius

Radius of helix base.

Top radius

Radius of helix top.

Axis endpoint

Endpoint location of the helix axis. The axis endpoint can be located anywhere in 3D space. The axis endpoint defines helix length and orientation.

Turns

Number of turns for helix.

Turn height

Height of one complete turn within the helix.

The number of turns will automatically update accordingly when a turn height value is specified. If the number of turns for the helix has been specified, you cannot enter a value for the turn height.

Twist

Direction of helix twist: clockwise (CW) or counterclockwise (CCW). CCW is default twist.

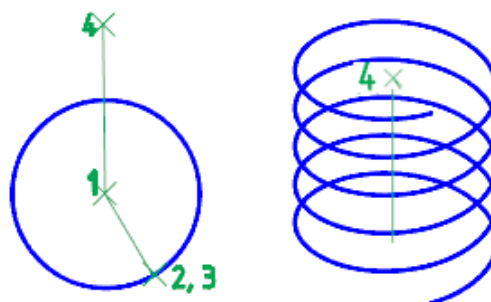

### Command prompts:

Specify center point of base:

Specify base radius or [Diameter]:

Specify top radius or [Diameter]:

Specify helix height or  
[Axis endpoint/Turns/turn Height/tWist]

Specify center (1) point.

Specify base radius (2). Click Diameter to specify base diameter.

Specify top radius. Click Diameter to specify top diameter.

Specify the height of helix (4).

## Add Selected



Ribbon: **Draw – Draw** >  **Add Selected**



Toolbar: **Draw** –  **Add Selected**



Command line: **ADDSELECTED**

The command can also be opened from the context menu.

The command creates a new object using type and properties of a selected object.

A new object of the type and properties (color, layer, line type and etc.) of selected object is created, but the command prompt to specify its geometric properties (length, radius, center point of circle and etc.) is shown.

### To create an object using a selected object:

1. Select an object.
2. Start the **Add selected** command.
3. Create an object according to the command prompts.

Prompts in the command line depend on selected object type.

## EDITING OBJECTS

To edit objects and their parameters you have to select them on the drawing. It is possible to edit them using grips and their properties in the **Properties** panel.

By double clicking on objects, the editing command starts or the **Properties** panel appears. According to the object's type, the editing command opens an editing dialog box (dimensions, notes) or offers to edit parameters in the command line (polylines, spline).

### Selection of Objects

To edit objects you have to select them.

There are different ways to select objects in nanoCAD. The most common way to select is to select objects with the mouse cursor without using additional commands. Objects can be selected both individually and in groups

*Selection of an individual object* is performed by hovering the cursor, followed by clicking on it with the left mouse button by .

*Selection of a group of objects* is performed using a rectangular selection window or a lasso.

- If you move the cursor in the drawing area while holding down the mouse button, the lasso outline will be drawn. To stop the selection, just release the mouse button.
- In case of a single click on an empty space in a drawing field, a rectangular selection window will begin to draw. A second click will mark the second vertex of the window and complete the selection process.

If after starting a group selection, the cursor moves to the right, a window or lasso with a blue semi-transparent fill is used. Only the objects that are entirely inside the specified area will be selected.

If after starting a group selection, the cursor moves to the left, a crossing window or lasso with green semi-transparent fill is used. This will select objects both completely inside and crossed by the border of the specified area.

When selecting with the lasso, you can cycle through its modes by pressing the **SPACEBAR**. The selection mode will change on the fly. You can skip between regular lasso selection (blue fill), crossing lasso selection (green fill) and lasso outline selection (only objects crossed by the outline are selected, but not those that are entirely inside or outside).

**Selection with window**

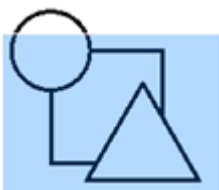

**Result**

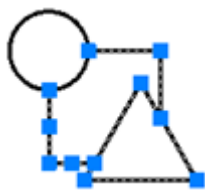

**Selection with crossing window**

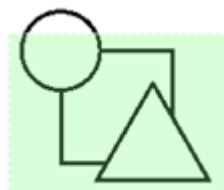

**Result**

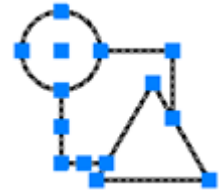

Selection of objects with three lasso modes:

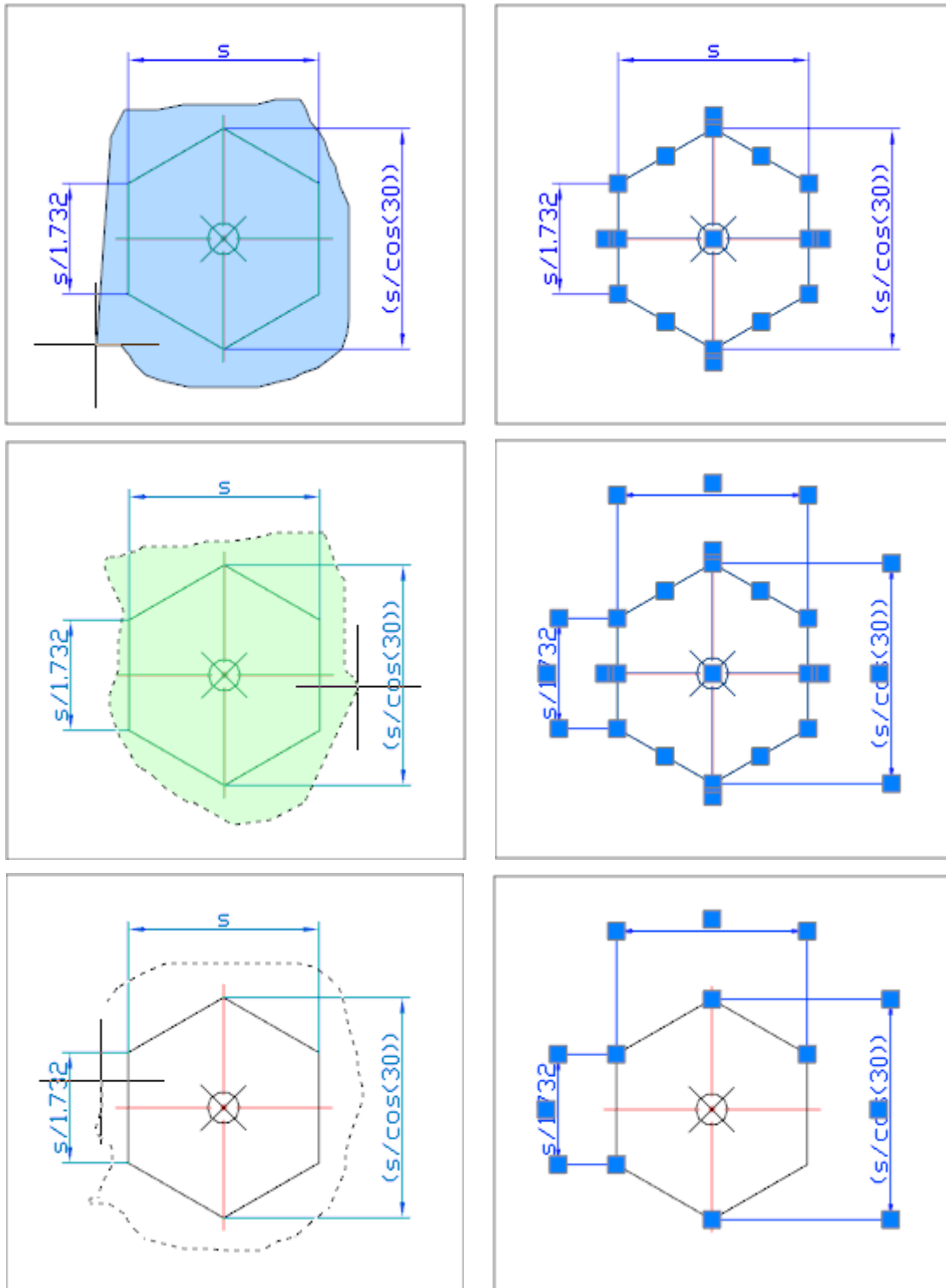

Selection parameters are set in **Select** section of **Options** dialog:

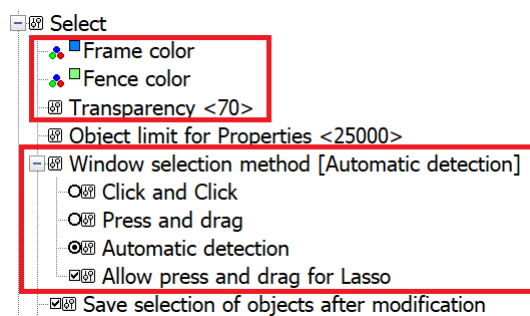



**Options:**

<b>Frame color</b>	
<b>Fence color</b>	Frame and fence displaying options.
<b>Transparency</b>	
<b>Selection preview method</b>	Sets the method of frame/fence creation.
<b>Click and Click</b>	Sets the frame by two clicks: first click starts selection, second click completes it.
<b>Press and drag</b>	Sets the frame by mouse drag: press to specify the first point, then drag cursor and release the mouse button.
<b>Both – Automatic detection</b>	Automatic detection of selected method.
<b>Allow press and drag for Lasso</b>	Enables/Disables lasso selection method.

**Keep pre-selection after modification**

Keep objects in selection after modify commands: **Move, Rotate, Scale**. For the **Move, Rotate** and **Scale** commands you can use the **Keep pre-selection after modification** mode, which allows you to keep objects selected even after the commands have stopped. The selection is cancelled by pressing the ESC key

**Preview of selected objects**

To preview objects of the selection or selection set, there is a mode of dynamic highlighting. Placed under cursor or pixbox objects or objects from set of selection objects are highlighted the same color, which they have.

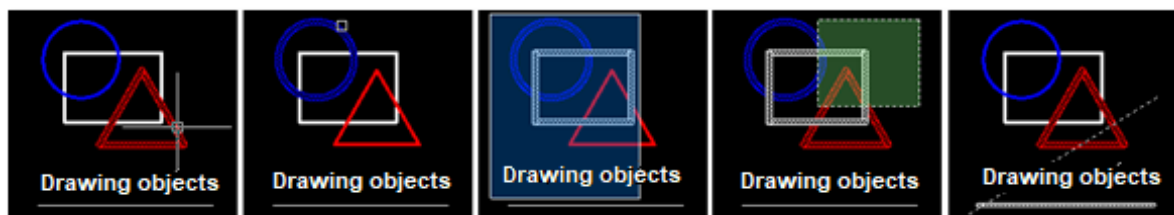

Control of preview of selected objects mode implemented by  **ToggleSelectionPreview** button in the status bar:

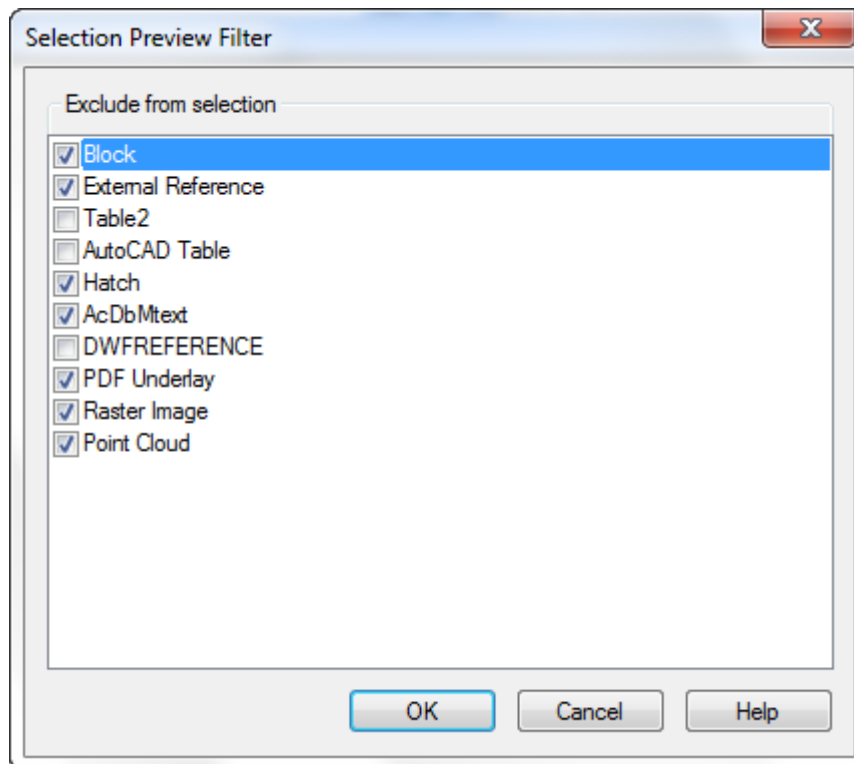

<b>In command mode</b>	Objects are highlighted only when any command is run (when command asks to select objects)
<b>In non-command mode</b>	Objects are highlighted in non-command selection mode (are not highlighted when a command is run).
<b>In all modes</b>	Dynamic highlighting is active in all modes.
<b>Never</b>	Preview of selection is off.
<b>Selection filter</b>	Opens <b>Selection Preview Filter</b> dialog. Check the box to exclude objects from selection preview. Checking boxes in the dialog box excludes objects from the selection preview. You can also open the dialog box using the SELFILTER command.

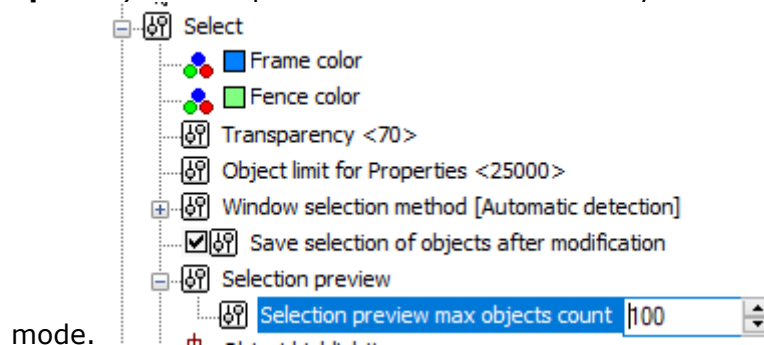

Maximum possible number of dynamically highlighted objects in preview is specified in **Select > Selection preview > Selection preview max objects count** of the **Options** dialog (**Tools** menu – **Options**). The 0 specified value turns off the dynamic highlighting



It is important which selection mode is selected in the **Properties** panel when you select objects:

- If the multiple selection mode is switched on (the button ) , all newly selected objects are added to the set. Objects selected in this mode are excluded from the set if you press **SHIFT**.
- If single selection mode is switched on (the button ) , only newly selected objects are added to the set. New objects selected in this mode are added to the set if you press **SHIFT** and already selected are excluded from the set.

## Selection of Objects Using the Command Line

For many editing commands, you can launch additional options for object selection in the command line.

1. Start the **Select** editing command from the command line

or

2. Start any editing command.

3. To the command prompt about object selection `Select objects or [?]:` enter `?` (question mark) or select from the context menu.
4. The following prompt is displayed in the command line: `Select an option or [Window/Last/Crossing/Box/All/Fence/Wpolygon/Cpolygon/Group/Add/Remove/Auto]:`
5. Select the required option.

### **Command options:**

<u>Window</u>	Selection of objects that are entirely inside the rectangular area, specified by two points from left to right.
<u>Last</u>	Selection of the last created object. Objects cannot be on a frozen layer.
<u>Crossing</u>	Selection of objects, crossed by the rectangular area or inside the rectangular area, specified by two points from right to left.
<u>Box</u>	Selection option, with choice of <u>Window</u> or <u>Crossing</u> options. If points in the rectangular area are specified from right to left, the selection of objects is equal to the <u>Crossing</u> option. If points in the rectangular area are specified from left to right, the selection of objects is equal to the <u>Window</u> option.
<u>All</u>	All objects are selected, excluding objects belonging to locked or frozen layers.
<u>Fence</u>	Selection of objects crossed by the selection line.
<u>WPolygon</u>	Selection of objects which are entirely inside the polygonal area. A polygon can have any shape, but there must not be any self-intersections. The segment of a polygon created last is the closing segment.
<u>CPolygon</u>	Selection of objects which are entirely inside the polygonal area or are crossed by this area. A polygon can have any shape, but there must not be any self-intersections. The segment of a polygon created last is the closing segment.
<u>Group</u>	Selection of objects in the specified group.
<u>Add</u>	Adds objects to the current set using any selection method. Automatic mode and adding mode are used by default ( <u>Auto</u> and <u>Add</u> modes).
<u>Remove</u>	Deletes objects in the current set using any selection method. You can exclude objects by pressing the <b>SHIFT</b> button in the adding mode ( <u>Add</u> mode) or automatic mode ( <u>Auto</u> mode).
<u>AUto</u>	Selection of objects with a pickbox. When an empty area is selected by the pickbox, the <u>Box</u> option is switched on and

the first point of the window or crossing window is specified.

Automatic mode and adding mode are used by default (Auto and Add modes).

Additional options of object selection are on a **Selection** toolbar. The toolbar can be quickly called from the command line:



Command line: **SHOWTOOLBAR\_SELECTION**



## Selection of All Objects



Ribbon: **Home – Utilities** >  **Select all objects**



Menu: **Edit –**  **Select all**



Hotkeys: **CTRL+A**



Command line: **SELECTALL**

The command allows the selection of all objects in the current drawing, except objects on frozen layers.

The command is available from the context menu.

To cancel the selection, press **ESC**.

## Remove from Selection



Ribbon: **Home – Utilities** >  **Remove from Selection**



Menu: **Edit – Remove from Selection**



Command line: **SELREMOVE**

Command removes objects of the specified type from selection set.

1. If you have a set of selected objects, start **Remove from Selection** command.
2. Specify the object to remove.

All objects of this type will be removed from selection.

## Leave in Selection



Ribbon: **Home – Utilities** >  **Leave in Selection**



Menu: **Edit –**  **Leave in Selection**



Command line: **SELLEAVE**

Command leaves objects of specified type in a selection set.

1. If you have a set of selected objects, start **Leave in Selection** command.

2. Specify the object to leave.

Only objects of this type will be left in selection.

## Invert Selection



Ribbon: **Home – Utilities** >  **Invert Selection**



Menu: **Edit - Invert Selection**



Command line: **SELINVERT**

Command cancels the current selection and selects all other objects.

## Select Similar Objects



Ribbon: **Home – Utilities** >  **Select Similar Objects**



Menu: **Edit –**  **Select Similar Objects**



Functional toolbar: **Properties–** 



Command line: **SELECTSIMILAR**

Command finds all objects within the current drawing that match the properties of selected objects, and then adds them to the selection set. With the **Settings** option, you specify which properties to match, such as color or block name, in the **Select Similar Settings** dialog box.

### Command options:

?

Additional object selection options.

Settings

Displays the **Select Similar Settings** dialog box, where you can specify which properties to match.

Region

Sets rectangular region to select similar objects inside.

### Command prompt:

Select patterns or  
[?/Settings/Region]

Select object serving as a pattern with desirable properties and select Settings option to set similar properties.

Settings option invokes **Select Similar Settings** dialog box where similar properties can be defined:

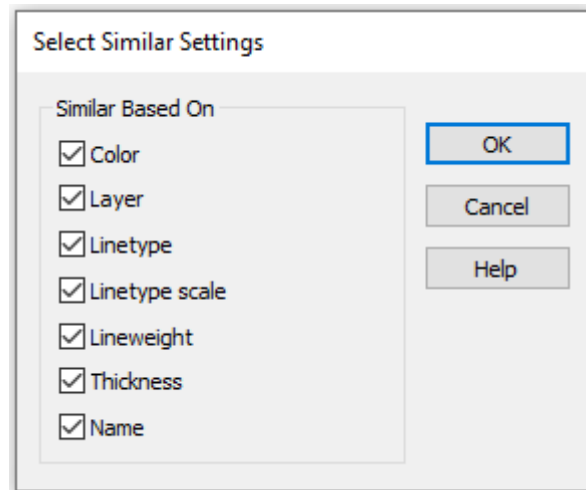

If no property is checked then objects of the same type as pattern object.

If just one property is checked (e.g. **Color**) then all objects with the color of the pattern object will be selected.

If more than one property are checked (e.g., **Color, Layer and Lineweight**) then will be selected:

- objects with the color of the pattern object;
- objects with the layer of the pattern object;
- objects with the lineweight of the pattern object.

If property **Name** is checked then all inserted objects with the same name as of pattern object (blocks, external references and images) will be selected.

Select patterns or  
[?/Settings/Region]

To select similar objects in the rectangular region:  
select **Region** option then set a rectangular area at  
the drawing.

Press **ENTER** to finish the command.

## Selection of Overlaid Objects



Ribbon: **Manage – Customization** >  **Select Dialog**



Menu: **View** –  **Show Selection Dialog**



Status bar:  **Show Selection Dialog**



Hot keys: **CTRL+W**



Command line: **SHOWSELDLG**

Selection of objects which are very close to each other is not difficult in nanoCAD.

If several objects are in the cursor's pickbox:

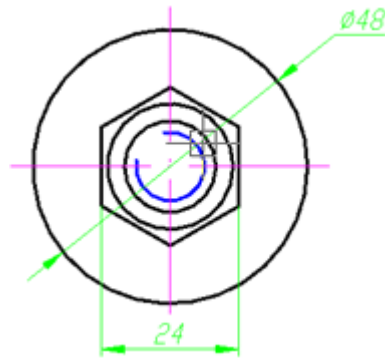

the dialog box automatically opens showing the list:

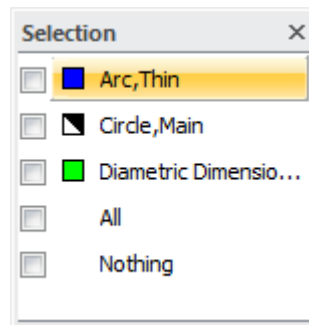

**Parameters:**

**All** Selection of all the objects in the dialog box list.

**Nothing** No objects in the dialog box list are selected.  
Pressing **ESC** also cancels the selection and closes the dialog box.

Place the cursor over any object in the list highlights it on the screen. Click on any object in the dialog box to select it. The dialog box closes after an object is selected.

To simultaneously select several objects from the list, check the boxes of the desired objects.

**Examples of different object selection:**

### Selection of arc object

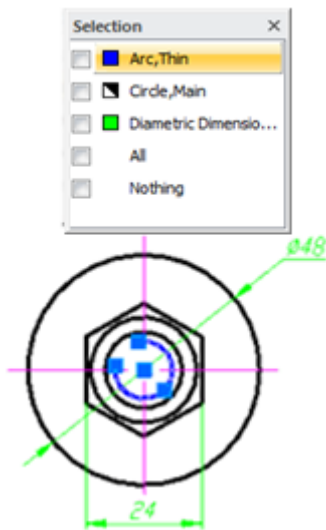

### Selection of diametric dimension object

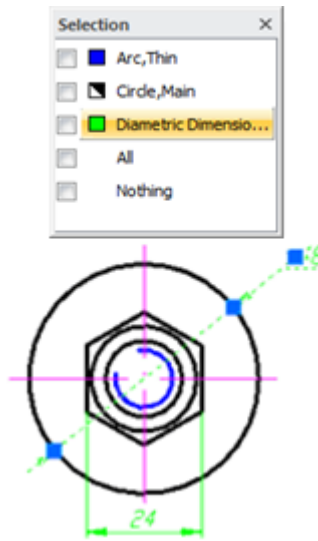

### Selection of all 3 objects: arc, diametric dimension and circle

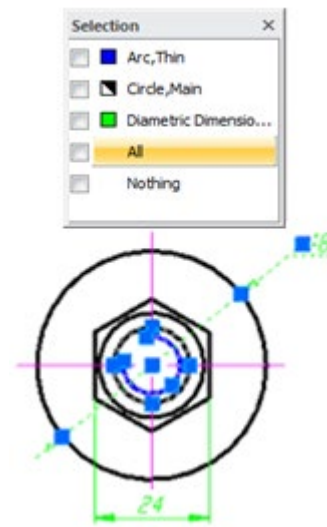



The **Show selection dialog** command from the **View** menu switches on/off display of the **Selection** dialog box.

## Selection of Objects Using the Properties Bar

 Ribbon: **Properties** >  **Properties**

 Menu: **Modify** –  **Properties...**

 Toolbar: **Main** – 

 Hotkeys: **CTRL**+**I**

 Command line: **INSP, INSPECTOR, PROPERTIES**

There are buttons of object selection modes and commands right below the **Properties** bar caption:



## Mode and Commands to Select Objects

### Modes of object selection









 **Multiple selection** Mode of multiple object selection; all selected objects are added to the previous selection set. **ESC** cancels the selection. Objects selected in this mode are excluded from the set if you press **SHIFT**.

 **Single selection** Mode of single object selection; all newly selected objects are added to the selection set. Previously selected objects are removed from the set.



You can also add new objects in selection set or exclude them. Hold the **SHIFT** button during selection to add new objects in current selection set. To unselect certain objects, click them with **SHIFT** button pressed.

### Commands of object selection

	<b>Select</b>	Selection of objects using the cursor.
	<b>Invert selection</b>	Cancels the current selection of objects and selects the rest of the drawing objects.
	<b>Select similar objects</b>	Only objects, whose properties correspond to the specified template object are selected.
	<b>Quick select</b>	Sets filter conditions and ways to create a selection set based on these conditions.
	<b>Remove from selection</b>	Excludes the specified objects from the selection set.
	<b>Leave in selection</b>	Leaves only the specified objects in the selection set.
	<b>Select All Objects</b>	Selection of all objects in the drawing.
	<b>Unselect All</b>	Cancels selection.

## To Remove Objects from a Selection Set

### To remove objects from a selection set:

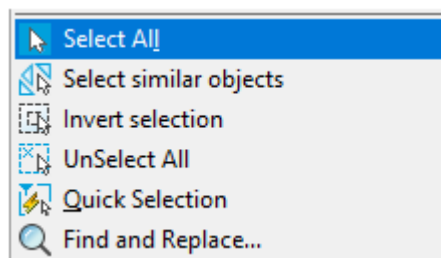

1. Choose the **Select all** in the context menu or from the **Edit** menu:

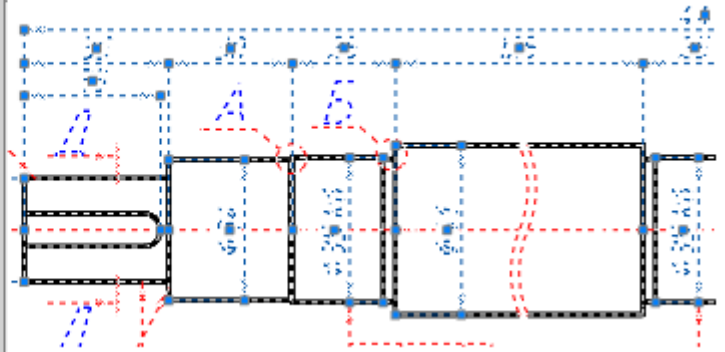
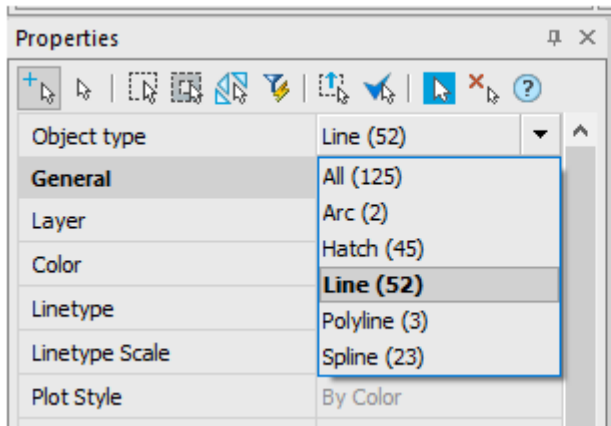

All objects in the drawing will be selected.

2. Choose the object type that you want to exclude from the set in the drop-down list in the **Object type** of the **Properties** bar:



3. Click the  **Remove from selection**. All objects of the specified type will be deleted from the selection set.
4. Select another type of object in the drop-down list.
5. Click the  **Remove from selection**.
6. Selection and removal of objects can be repeated until only the required objects remain.

## To Leave Objects in a Selection Set

### To leave only specified objects in a selection set:

1. Choose **Select all** in the context menu or from the **Edit** menu. All the objects in the drawing will be selected.
2. Choose the object type which you want to exclude from the set in the drop-down list in the **Object type** of the **Properties** bar.
3. Click the  **Leave in selection**. All objects, except the specified type, will be deleted from the selection set.

## Quick Selection of Objects

Using the **Quick selection** command you can select objects using specified conditions.



Ribbon: **Home – Utilities** >  **Quick Selection**



Menu: **Edit** –  **Quick Selection...**



Command line: **QS, QSELECT**

The **Quick Selection** command can be launched from the context menu:

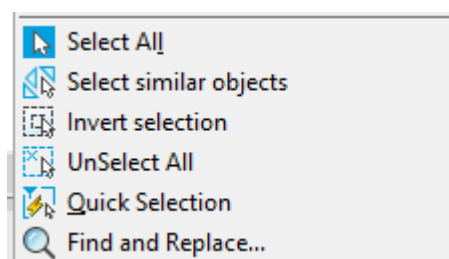

In the **Quick Selection** dialog box, you can adjust the search conditions:

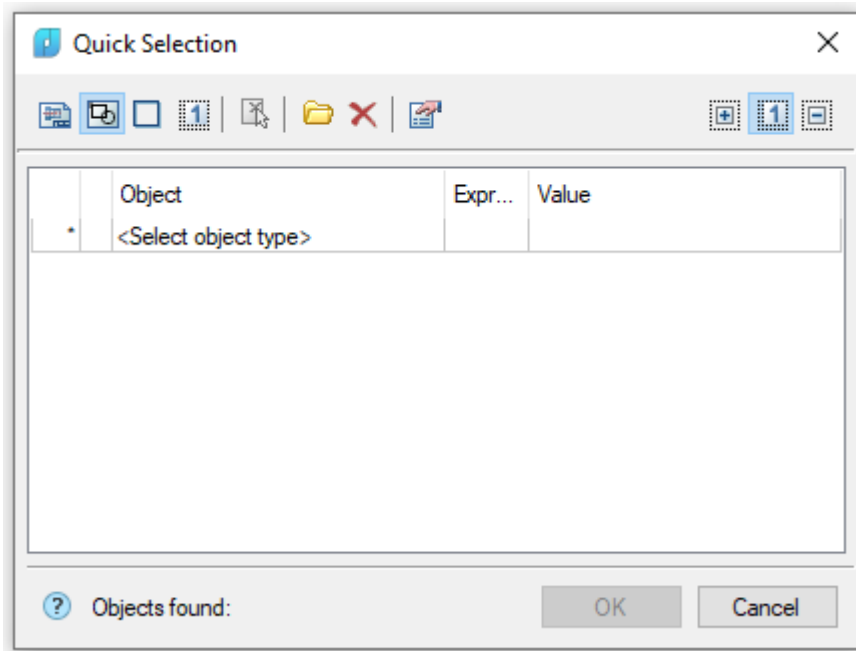

### Parameters:

#### Search

There are selection areas in the status bar:



#### Search options:



**In the whole document** – search in the whole document.



**In the current space** – search in the current space.



**In bounding box** – search in the selected rectangular area in the drawing.



**In current selection** – search among selected objects in the drawing.

If **In bounding box** or **In current selection** is selected, the **Quick Selection** dialog box temporarily closes to allow the rectangular area to be specified on the screen or for objects to be selected. The **Set selection** button becomes available after the area is specified or the objects are selected; using this button you can select a new rectangular area or change the current set of objects.



**Selection parameters. Include frozen and invisible layers** – allows to search objects on frozen and invisible layers

#### The following methods are available:



**Result set to new selection** – Objects corresponding to the specified search conditions are selected in the drawing, other objects are deselected.



**Result add to selection** – Found objects will be added to the selected objects on the drawing.



**Result subtract from selection** – If objects were selected, they become deselected.

**Filter template s:**



**Presets**

The button to call template managing functions and the list of saved templates.

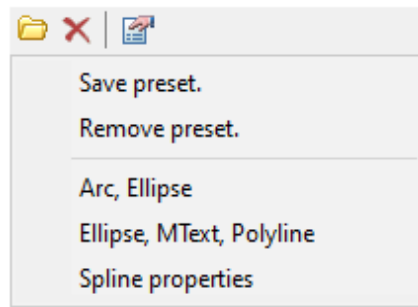

**Save preset**

Saves the preset selection conditions as a named template.

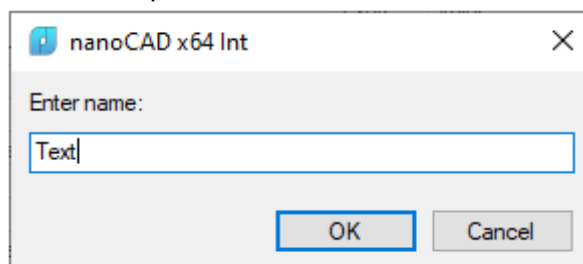

**Remove preset**

Removes a preset selected in the list.

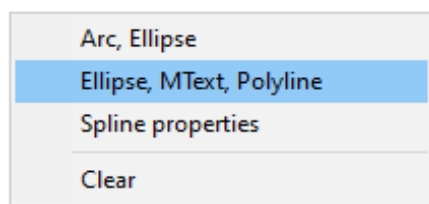

**Reset conditions**

Using a set of tools you can select objects using set and saved conditions.



**QS parameters**

Switches on/off selection at frozen and invisible layers.

**To add a condition for object search:**

1. Click in the **<Select object type>** field and choose the required object type from the list:



To reject the selection, click on **None**.

2. There is a list of parameters of all objects belonging to this type and to the specified selection area:

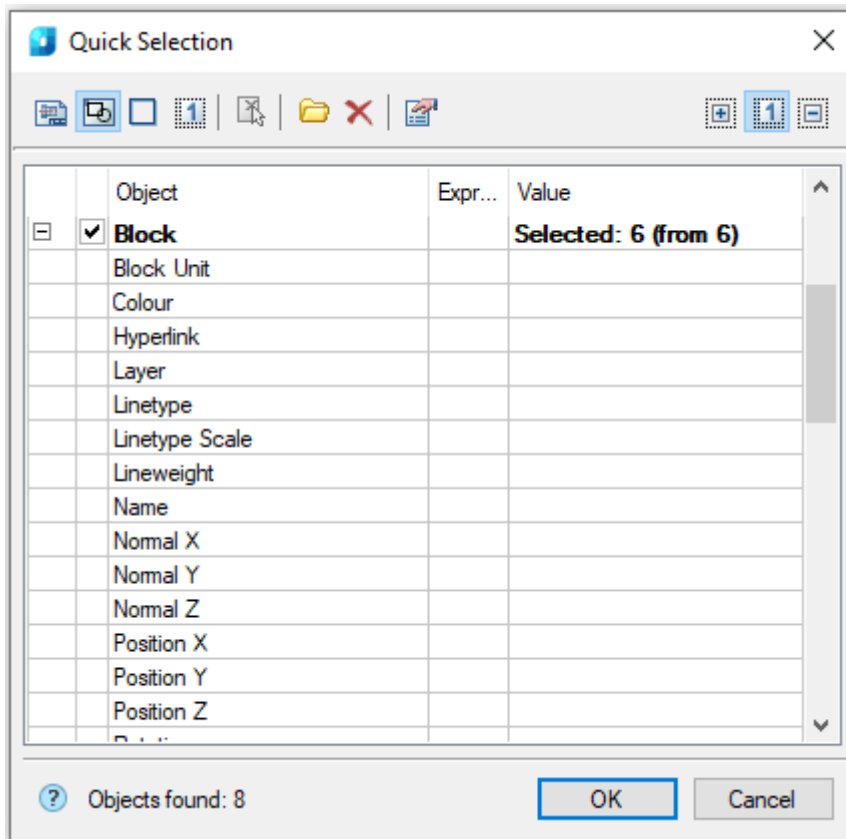

3. Select the value of the required search parameter in the **Value** column:

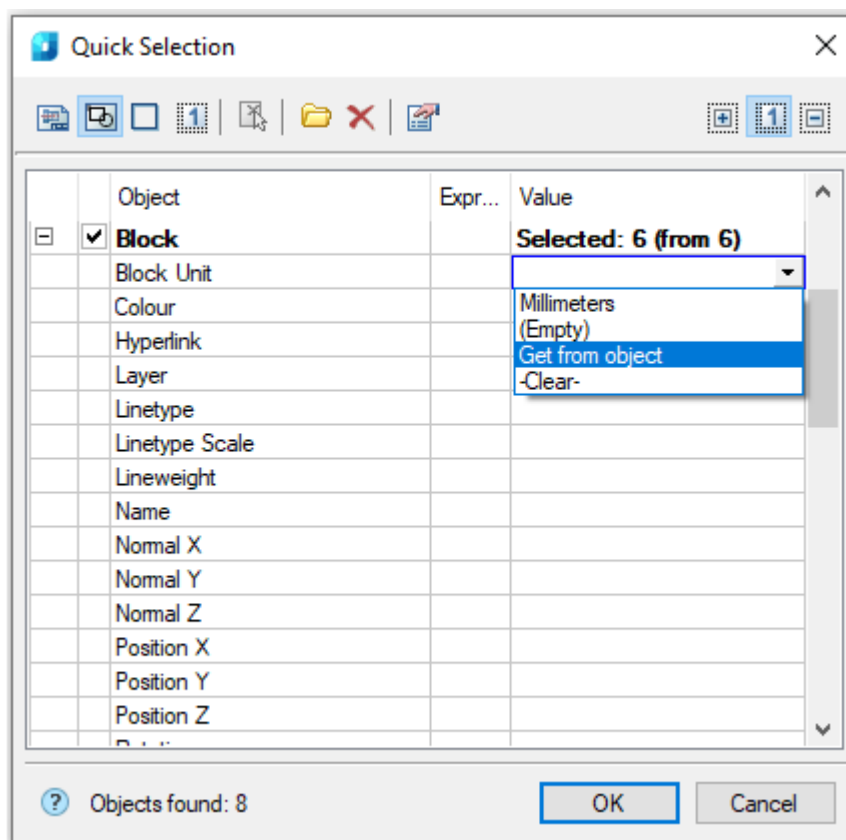

4. Select a logic search condition in the **ExprType** column:

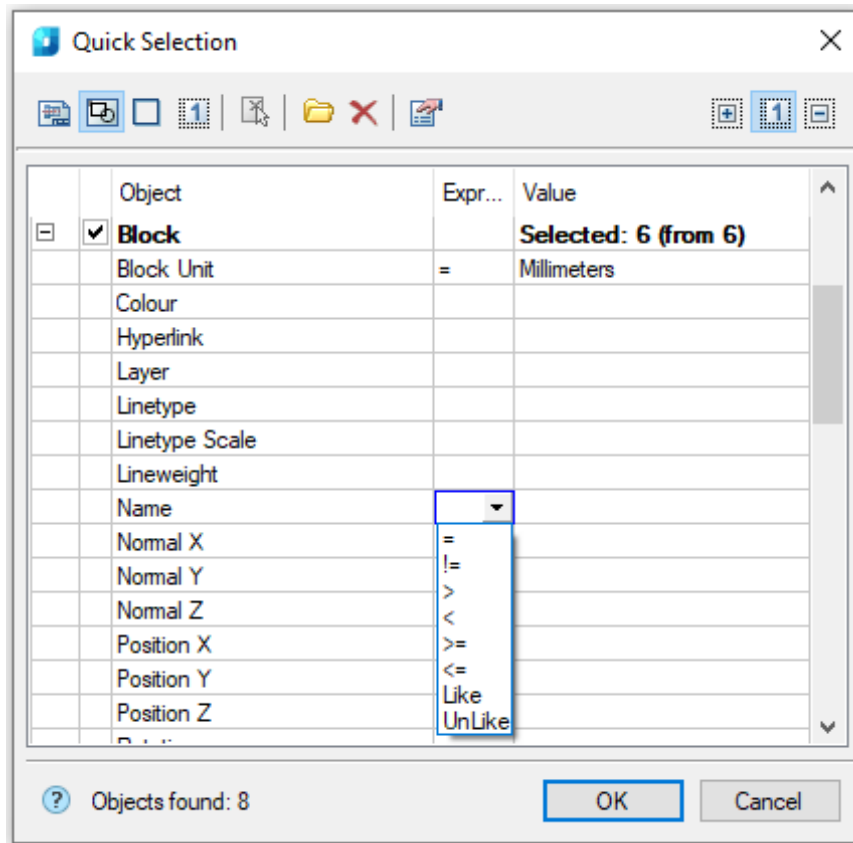

Available logic conditions for search:

=	equals
!=	does not equal
<	less
>	more
>=	not less
<=	not more
<b>Like</b>	Search of substring. Searches for objects whose parameter value contains the substring specified in the <b>ExprType</b> column.
<b>Unlike</b>	Search of substring. Searches for objects whose parameter value does not contain the substring specified in the <b>ExprType</b> column.

**NOTE:** For every object type you can set numerous search conditions using one or several parameters.

- To add another type of object, click on the **<Select object type>** bottom field:

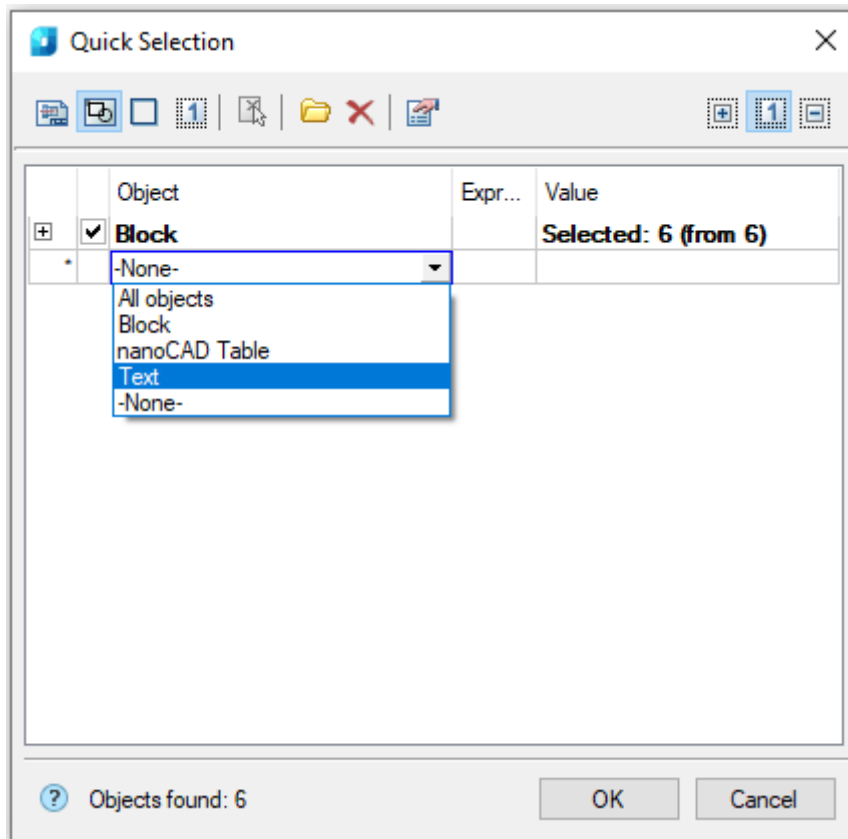

The number of objects satisfying the search conditions is displayed in the bottom part of the dialog box: **Object found: 9**.

## “Quick select” Functional Bar

**Quick select** functional bar is implemented for more convenient work.



Menu: **View – Toolbars > Functional > Selection**



Command line: **TABS > Selection**

**Selection** bar functions like **Quick selection** dialog box.

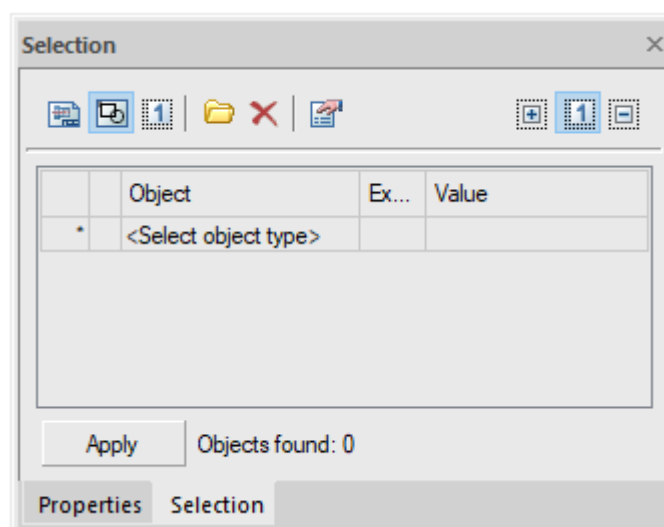







## Ways to Edit Objects

You can edit objects (change their properties) in different ways:

- Editing with the **Styles** toolbar; when a text or dimension style for the selected objects is changed.
- Using the **Main** toolbar; when a layer, color, type or lineweight for the selected objects are changed.
- Using the **Properties** bar (for more information see the "Properties bar" section).
- Editing of text objects (search and replace) using the **Find and Replace** (for more information see the "Find and replace text" section).
- Using the **Copy object properties** command.
- Using the Windows clipboard.
- Editing with *grips*; the selected objects are highlighted (object lines become dotted) and marked with special markers, small blue rectangles, placed at the characteristic points of the objects. The markers of grips can be triangles, circles, rhombs etc. The color of markers can be light blue or green.
- Editing using editing commands; the editing command starts (for example, **Copy** from the **Edit** menu) and objects are selected. For many commands you can first select objects and then start the editing command.
- Editing by double clicking on an object and an editing command relevant to the object's type starts. It can be the **Properties** bar, if it was closed. The editing command can open a dialog box to edit the object's properties (dimensions, notes, tables etc.) or offer to edit in the command line (for example, polylines and splines).

## Copy of Objects Properties

-  Ribbon: **Home – Properties** >  **Match properties**
-  Menu: **Modify** –  **Copy object properties**
-  Toolbar: **Main** – 
-  Command line: **MATCHPROP, MA, COPYOBJECTPROPS**

This command is used to copy a part of the selected object properties or all of them and assign them to one or several objects.

You can copy color, layer, linetype, lineweight and other properties.

### Command options:

? Opens additional options to select objects.

Settings Opens the **Property Settings** dialog.

### Command prompts:

Select source objects or [?]:

Select a source object.

Select destination object(s) or [?/Settings]:

Select object(s) to assign the copied properties to or select the Settings.



Select destination object(s) or [?/Settings]:

Select object(s) or press ENTER to finish the command.

The **Settings** option opens the **Property Settings** dialog box where you can specify the copied properties from the source object:

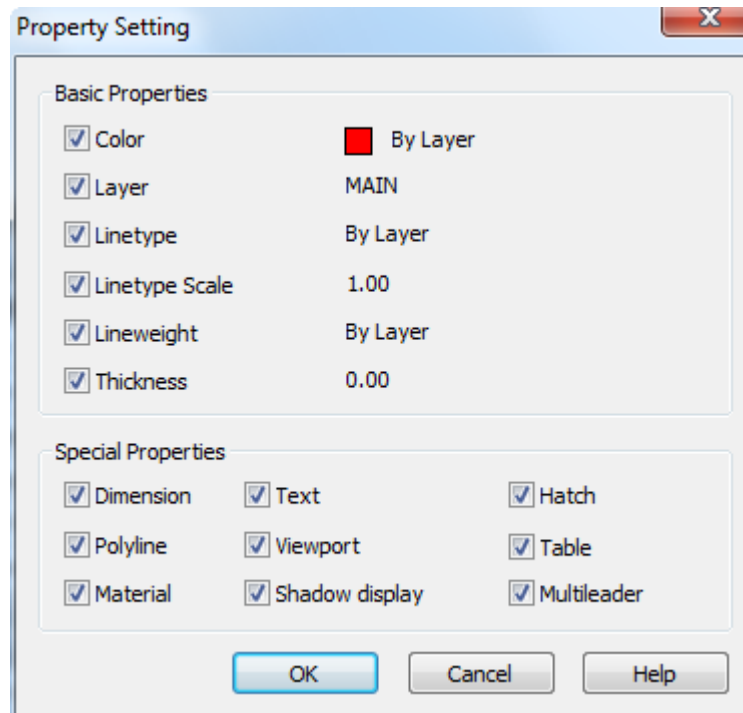

### **Parameters:**

#### *Basic properties*

**Color** Switches on/off the color copying mode.

**Layer** Switches on/off the layer copying mode.

**Linetype** Switches on/off the linetype copying mode.

**Linetype Scale** Switches on/off the linetype scale copying mode.

**Lineweight** Switches on/off the lineweight copying mode.

**Thickness** Switches on/off the thickness copying mode.

#### *Special properties*

**Dimension** Switches on/off the dimension style copying mode.

**Polyline** Switches on/off the width and type of polyline copying mode.

**Material** Switches on/off the material copying mode.

**Text** Switches on/off the text style copying mode.  
When copying a [note](#) properties, if the **Text** checkbox is unchecked,

only the text style of the note will be copied, without the text itself.

To copy note properties without copying the text content, you can also use the  **Match Properties** button in the note creation/editing dialog.

**Viewport** Switches on/off the viewport properties copying mode.

**Shadow display** Switches on/off the shadow display copying mode.

**Hatch** Switches on/off the hatch properties copying mode.

**Table** Switches on/off the table style copying mode.

**Multileader** Switches on/off the leader note style copying mode.

**NOTE:** When copying leader properties from the menu **Draw > Mleader**, there is one feature:

- if the **Text** box is checked, then in addition to the text style, the leader text itself is copied;
- to copy properties without text, clear the **Text** checkbox.

You can also copy leader properties without copying text using the **Match properties** button in dialogs of creating/editing leaders.

## *Copying and Insertion of Objects Using Clipboard*

The clipboard can be used to copy a drawing or part of it from one document to another. Data copied to the clipboard can be inserted into other applications, for example into open documents in MS Office.

nanoCAD commands using the clipboard are in the **Edit** menu:

- Ribbon: **Home – Clipboard**

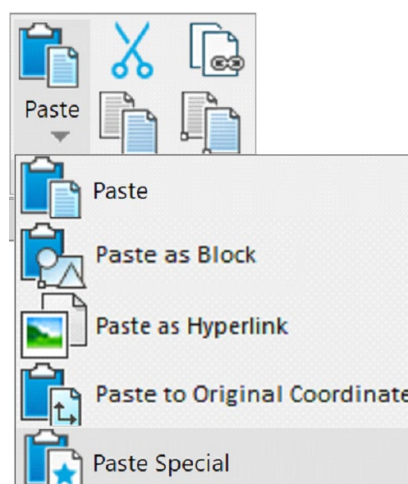

- Menu **Edit**
- **Edit** toolbar

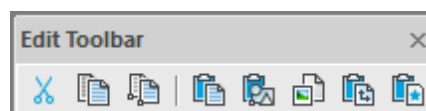

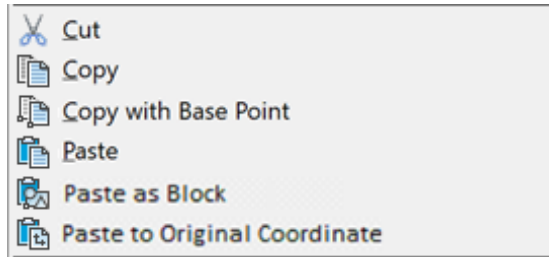

- Context menu





## Cut

 Ribbon: **Home – Clipboard >**  **Cut**

 Menu: **Edit –**  **Cut**

 Toolbar: **Main –** 

 Hotkeys: **CTRL+X**

 Command line: **CUT, CUTCLIP**

This command deletes the selected objects from the document and places them on the clipboard.

### Command option:

 Starts additional options for objects selection.



### Command prompt:

Select objects or []: Select objects, press **ENTER** to finish selection.

## Copy

 Ribbon: **Home – Clipboard >**  **Copy**

 Menu: **Edit –**  **Copy**

 Toolbar: **Main –** 

 Hotkeys: **CTRL+C**

 Command line: **COPYCLIP**

This command copies the selected objects and places a copy of them on the clipboard.

### Command option:

 Starts additional options for objects selection.

### Command prompt:

Select objects or []: Select objects, press **ENTER** to finish selection.

## Copy With Base Point

 Ribbon: **Home – Clipboard >**  **Copy With Base Point**

 Menu: **Edit** –  **Copy With Base Point**

 Hotkeys: **CTRL**+**SHIFT**+**C**

 Command line: **COPYBASE**

This command copies the selected objects and places a copy of them on the clipboard. When copying, a base point is specified and it is used to insert a copy of the objects into the document.

#### **Command option:**

? Starts additional options for objects selection.

#### **Command prompts:**

Select objects or [?]: Select objects, press **ENTER** to finish selection.  
Specify base point: Specify a point.

## **Copy OLE-Link**

 Ribbon: **Home** – **Clipboard** >  **Copy link**

 Menu: **Edit** –  **Copy link**

 Command line: **COPYLINC**

Copies *the current view* to the clipboard for linking with other OLE applications.

The clipboard contents will be pasted into another document as a linked OLE object.

## **Paste**

 Ribbon: **Home** – **Clipboard** >  **Paste**

 Menu: **Edit** –  **Paste**

 Toolbar: **Main** – 

 Hotkeys: **CTRL**+**V**

 Command line: **PASTE, PASTECLIP**

This command inserts the contents of the clipboard into the document.

#### **Command options:**

Mode Selection of insertion mode.  
The option starts the following prompt in the command line:  
Enter paste mode [Single/Multiple]<Single>:







#### **Options:**

Single - Mode of single insertion.  
Multiple - Mode of multiple insertions.

### Command prompts:

Specify insertion point or [Mode]:	Select <u>Mode</u> option.
Enter paste mode [ <u>Single/Multiple</u> ]<Single>:	Select <u>Multiple</u> option.
Specify insertion point or [Mode]:	Specify an insertion point.
Specify insertion point or [Mode]:	Specify an insertion point.
Specify insertion point or [Mode]:	Press <b>ESC</b> to finish the command.

## Paste as Block

-  Ribbon: **Home – Clipboard** >  **Paste as Block**
-  Menu: **Edit – Paste As** >  **As Block**
-  Hotkeys: **CTRL+SHIFT+V**
-  Command line: **PASTEBLOCK**

This command inserts the contents of the clipboard as a block into the document.

### Command options:

Mode Selection of block insertion mode.  
 The option starts the following prompt in the command line:  
 Enter paste mode [Single/Multiple]<Single>:

#### Options:



Single - Mode of single insertion.  
Multiple - Mode of multiple insertions.

Name Specifies a block's name for insertion.

### Command prompts:

Specify insertion point or [Mode/Name]:	Select <u>Mode</u> option.
Enter paste mode [ <u>Single/Multiple</u> ]<Single>:	Select <u>Multiple</u> option.
Specify insertion point or [Mode/Name]:	Select <u>Name</u> option.
Enter block name <Clipboard20212>:	Enter a block's name or press <b>ENTER</b> .
Specify insertion point or [Mode/Name]:	Specify an insertion point.
Specify insertion point or [Mode]:	Specify an insertion point.
Specify insertion point or [Mode]:	Press <b>ESC</b> to finish the command.

## Paste as Raster

-  Ribbon: **Home – Clipboard** >  **Paste as Hyperlink**
-  Menu: **Edit – Paste As** > **As Raster**



Command line: **PASTEASRASTER**

Command inserts raster image from clipboard to current document. Can be useful for inserting scanned drawings as backgrounds or for future editing using commands from **Raster** menu.

Raster image will be inserted as external reference with default name *Clipboard\_N*, where *N* – order number of inserted raster image. Link will have **Not Found** status. On the next document save operation **Save Image File** dialog will be displayed. In this dialog you can specify path, raster image file name and format. If more than one raster images were inserted - **Save Image File** dialog will be displayed for each image.

After saving status will be changed to **Loaded**, and in **External References** dialog (menu **Insert – External references**) raster image parameters will be displayed.

From this dialog it's possible to save the raster image without saving the document. **Save** button will open the same **Save Image File** dialog.

Note: **Options** button in **Save Image File** dialog allows to specify more options for some raster formats (for detailed information see [Image settings](#) section).

#### Command options:

Specify insertion point:

Specify point of raster image insertion.

## Paste to Original Coordinates



Ribbon: **Home – Clipboard** >  **Paste to Original Coordinates**



Menu: **Edit** –  **Paste to original coordinates**



Command line: **PASTEORIGIN**

This command inserts objects from the clipboard into the document with the same coordinates that they had in the initial document.

The command is applicable if the clipboard contains graphic data copied from other drawings.

This insertion method is useful when copying objects from one drawing to another to maintain geometry alignment. For example, for different floors of a building.

## Paste Special



Ribbon: **Home – Clipboard** >  **Paste special**



Menu: **Edit** –  **Paste Special**



Command line: **PASTESPEC**

The command pastes objects in the current document, which allows managing data format.

#### Options:

##### Data source

Contains information about the data copied to the clipboard. The kind of information depends on the type of data.

For example, for Excel document data, it displays the layout name and the range of copied cells:

Source: Layout1!R1C1:R3C3

- Paste** The clipboard content will be pasted to the specified location in the drawing as an embedded object. Embedded data cannot be updated in the drawing workspace if modified in the original document from where they were inserted.
- Paste link** The clipboard content will be pasted to the specified location in the drawing as linked data.  
 If the source application supports OLE or a data link, a link to the source file will be created. Linked data can be updated in the drawing workspace if modified in the original document from where they were inserted.  
 OLE object links are updated and configured in the [Update OLE-links](#) dialog box of the Update Data Links command
- As:** Formats in which you can paste the clipboard content into the current drawing. Depend on the type of data in the clipboard and the type of insertion (embed or bind).
- As an icon** Instead of data, the corresponding application icon will be placed in the drawing. To view or edit data, double-click the left mouse button on the icon.

## ***Copying Objects and Creating a Block by Dragging with the Right Mouse Button***

By dragging objects with the right mouse button, you can create their copies or create insertions of a new block from these objects. After dragging the selection, the context menu is displayed with possible variants of copying:

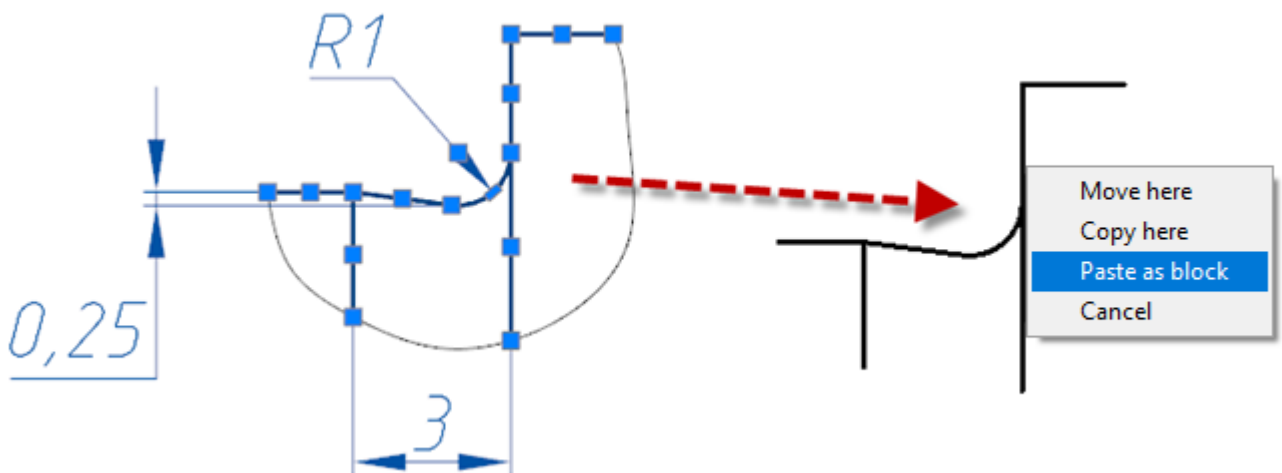

If you select the **Paste as block** option, a new block with insertion in the place of transfer will be created in the document.

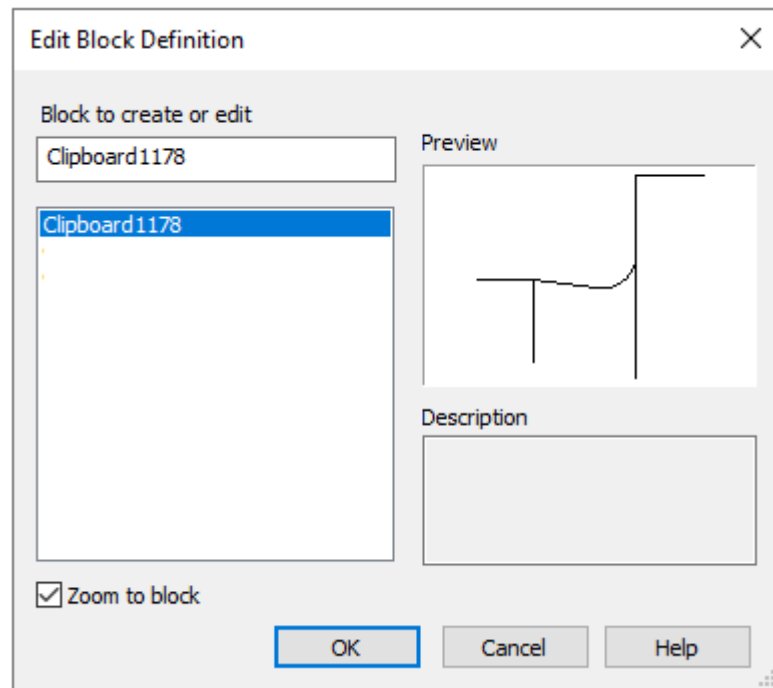

## Editing Objects Using Ordinary Grips

Editing commands can be applied to objects previously selected and marked with grips. Available parameters can be changed on the **Properties** panel. Sometimes, editing with grips without using commands from the **Edit** menu is the quickest and most effective method to change the shape and location of objects because actions with grips are performed with the cursor, so you do not need to use menus and toolbars.

There are two ways to edit objects using grips in nanoCAD:

- Editing objects using *ordinary* grips.
- Editing objects using *multifunctional* grips (for more information see the "Editing objects using multifunctional grips" section).

You can use ordinary grips to move, copy, stretch or scale objects.

The number and location of grips depends on the selected object's type; for example, a line segment has 3 grips. Two of them located at the endpoints and one in the middle, 5 grips are displayed for circle, four of them are located in the quadrants and one in the center etc.:

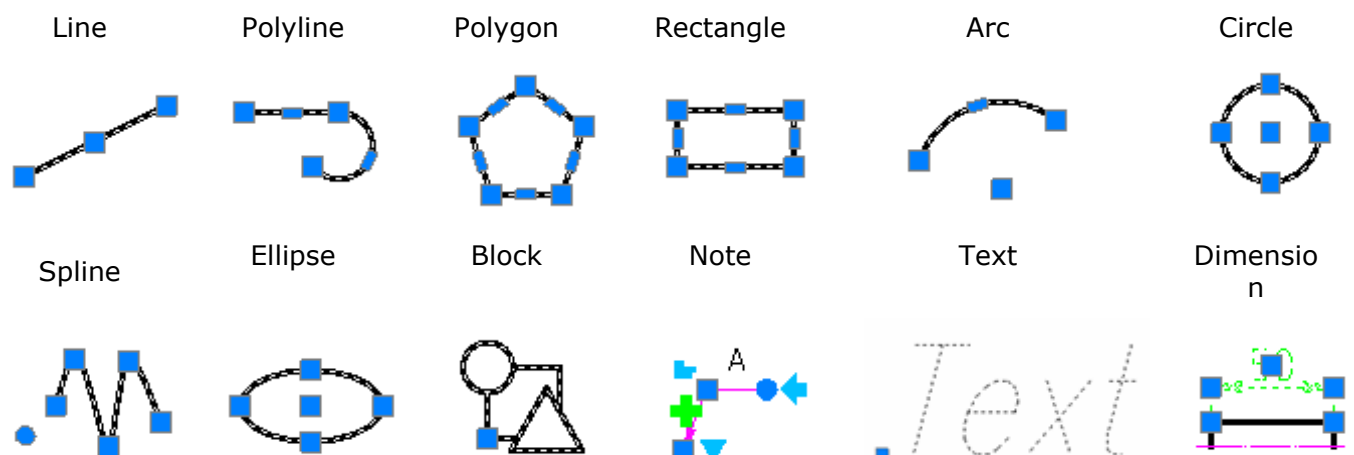

**ATTENTION!** Grips are not displayed for objects on locked layers.



By default the “Stretch” (**GRIP\_STRETCH**) mode is set to edit objects with grips.

To switch to the editing mode with ordinary grips, click on any grip after an object is selected. The selected grip becomes **active** and changes its color to red. This grip is used to perform editing operations and is called the **base**. According to grip selected as the **base**, the object can be stretched or moved, by moving the cursor (for example, if a middle grip of object is selected, the object is moved, if any of end grips of object is selected, the object is stretched). The selected base grip is snapped to the cursor’s crosshair and moved with it until you click to specify a new grip position.

Any grip in the drawing can be specified as the base if you select the **Base** option in the command line after the base point is selected:

Specify stretch point or [Base/Copy/Undo/eXit]:

**Options available in the command line for editing with grips:**

- Base                Specifies a point as the base.
- Copy                Switches to copying mode.
- Undo                Cancels the last operation.
- eXit                Exits from the editing with grips mode. The display mode of the selected objects is not cancelled.

You can make several grips of object *active* if the **SHIFT** button is pressed during grips selection. Shape of object between active (selected) grips does not change. Editing mode is switched on after one of these grips is selected as the **base** (select it without **SHIFT** button).

When several objects are selected, shape and position of objects with no active grips do not change.

**To stretch several objects using grips:**

1. Select objects.
2. With the **SHIFT** button pressed select the required grips on the objects (highlighted with red).
3. Release the **SHIFT** button.
4. Select a base grip.
5. Specify a new position of base point.

## **Movement, Rotation, Scale, Mirror**

Besides the “Stretch” mode, there are additional modes to work with grips: “Movement” (**GRIP\_MOVE**), “Rotation” (**GRIP\_ROTATE**), “Scale” (**GRIP\_SCALE**) and “Mirror” (**GRIP\_MIRROR**). You have to press the **ENTER** button or the spacebar for round robin of additional modes.

In “Rotation” and “Scale” modes there is a Reference option in the command line prompt:

Specify scale factor or [Base point/Copy/Undo/Reference/eXit]:

Specify rotation angle or [Base point/Copy/Undo/Reference/eXit]:

The option allows specifying a reference angle when rotating or referencing segment when scaling.

**To edit several objects using grips:**

1. Select objects.
2. Select a base grip.
3. You have to press the **ENTER** button or the spacebar for round robin of additional modes (movement, rotation, scale, mirror, stretching).
4. Move the cursor to dynamically display changes of the object.
5. Click to finish changes.

## Modified Copies Using Ctrl

It is possible to create modified copies of an object by specifying a new location of grips with **CTRL** button pressed.

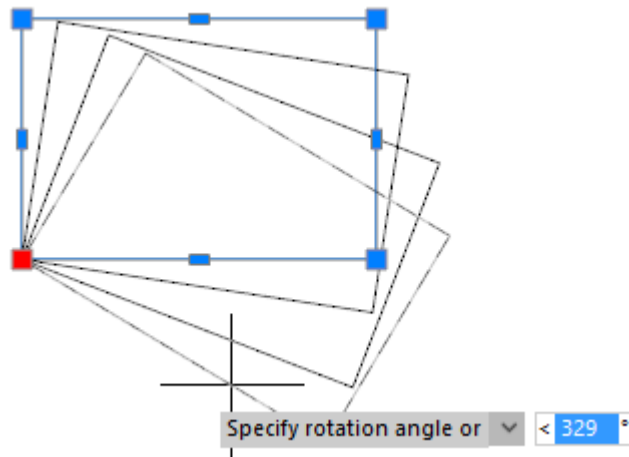

To do this:

1. Select one or more grips.
2. If you need not to stretch, but move, rotate, scale, mirror, switch to the desired editing mode by pressing **SPACE** or **ENTER**.
3. Press **CTRL** and without releasing it, indicate the new positions/modifications of the object by clicking the mouse on the screen. Each time you click the mouse while holding **CTRL** down, modified copies of the edited object will be created.

This mode of creating modified copies using **CTRL** is also available for multifunctional grips with their edit modes.

## Grips Settings

You can change grips in the **Grips** section of the **Options** dialog (**Tools** menu– **Options**):

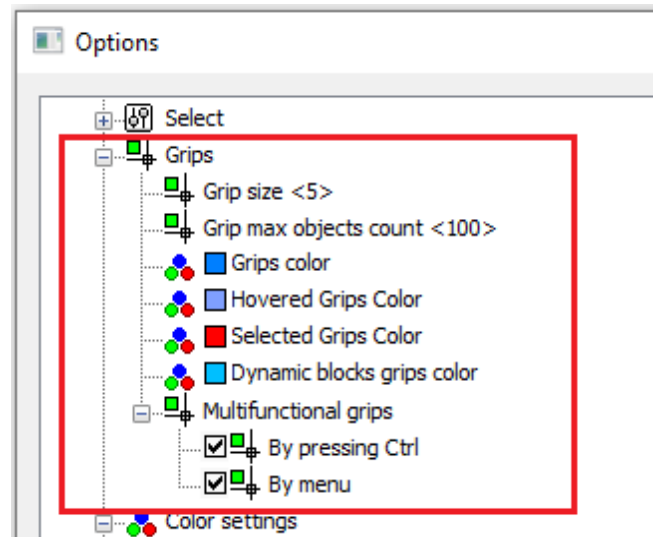

The **Grip max objects count** limits a number of objects with displayed grips. It is required to increase productivity, because it takes a lot of time to select objects in drawings with a great number of objects with a great number of grips (hatches, polylines). Default value is 100 (a value is stored in a system variable - **GRIPOBJLIMIT**).

## Editing Objects Using Multifunctional Grips

Grips that can change editing mode by round robin in rotation are called *multifunctional*. Rotation of editing modes is carried out for the active (selected) grip using the **CTRL** button.

*Multifunctional* are grips that have an ability to change edit modes by *Cycling* or by calling a *Dynamic menu*.

*Cycling* through the edit modes is carried out for the active (selected) grip by pressing the **CTRL** key.

A *dynamic menu* of the edit modes appears when you hover the cursor over the grip.

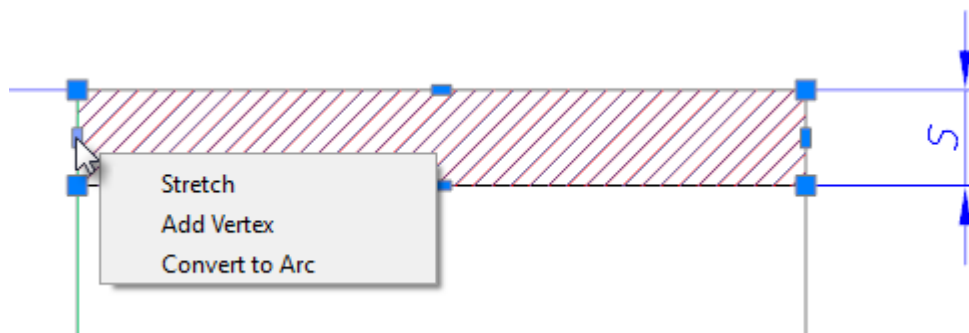

The dynamic menu items can be selected both by the mouse cursor, and by **ARROW UP** / **ARROW DOWN** keys on the keyboard.

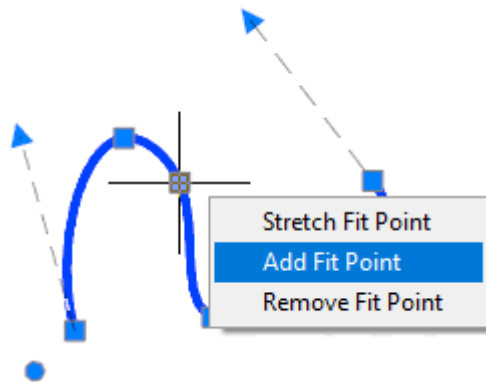

The method of access to commands to edit objects using multifunctional grips (GRIPMULTIFUNCTIONAL system variable) is selected in the section **Grips > Multifunctional grips** of the [Options](#) dialog box.



Objects which have multifunctional grips:

- line segment,
- arc,
- spline,
- polyline,
- hatch,
- viewport.

**To edit objects with multifunctional grips:**

1. Select an object.
2. Activate the multifunctional grip.
3. Press **CTRL** to select the editing variant.
4. Move the cursor for dynamic display of an object's properties.
5. Click to confirm the change.

## Segment Editing

A line segment has multifunctional grips at the endpoint. Two editing modes are available:

- *Normal mode*: the length of the segment changes when you move the grip. In general, not only the segment length is changed, but also its orientation.
- *Change of length*: only the length of the segment changes when you move the grip. A new position for the endpoint is provided by the projection of the specified point along the segment's imaginary extension. Segment orientation is not changed.

Normal mode

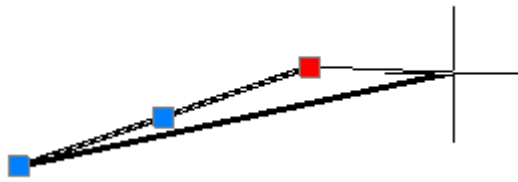

Change of length

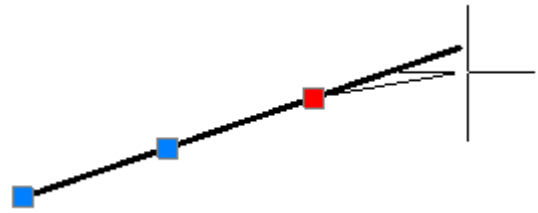

## Arc Editing

Multifunctional grips are at the endpoints and in the middle of the arc. Three editing modes are available:

- *Normal mode*: when you hold and move a grip on the end or middle point, the length and radius are changed:

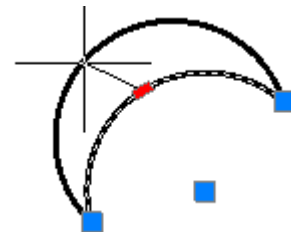
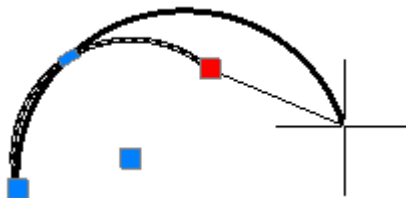

- *Change of arc length*: when you hold and move a grip on the end point, only the length is changed:

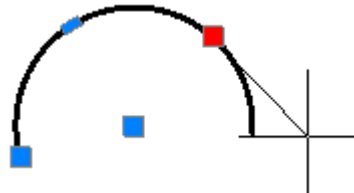

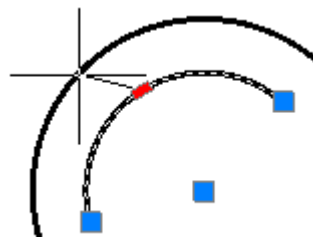

- *Change of arc radius and length*, when you hold and move the grip on the middle point, an arc is created similar to the source arc:





## Polyline Editing

Polyline has multifunctional grips at the end of the segments and in the middle of the segments. Rotational editing modes, accessed with the **CTRL** button, depend on the location of the grips (end point or middle point) and segment type (linear or arc).

For improved functionality, additional symbols are displayed beside the polyline shape and near the cursor. Which symbols are shown depends on the editing mode selected:

-  Adds a vertex
-  Deletes a vertex.

-  Transforms a linear segment to an arc.
-  Transforms an arc segment to linear.

Absence of a symbol means that the normal editing mode is current - stretching by moving a segment or stretching a vertex (depends on selected grip).

*Variants of polyline editing with grips in vertexes*

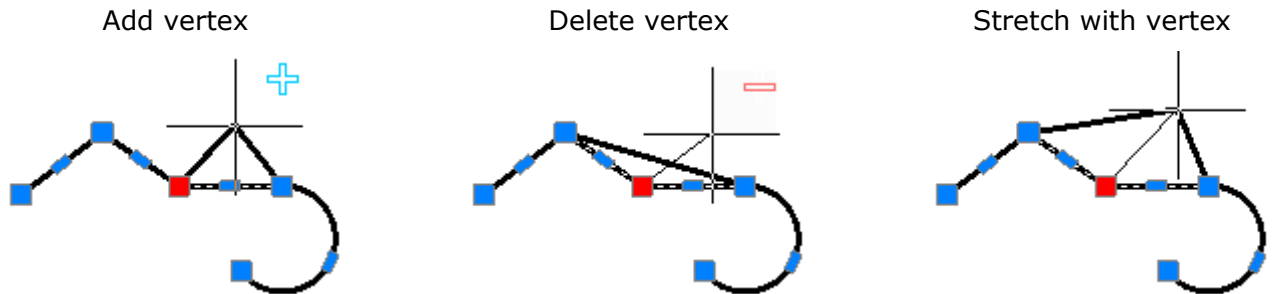

*Variants of polyline editing with grips in the middle of a linear segment:*

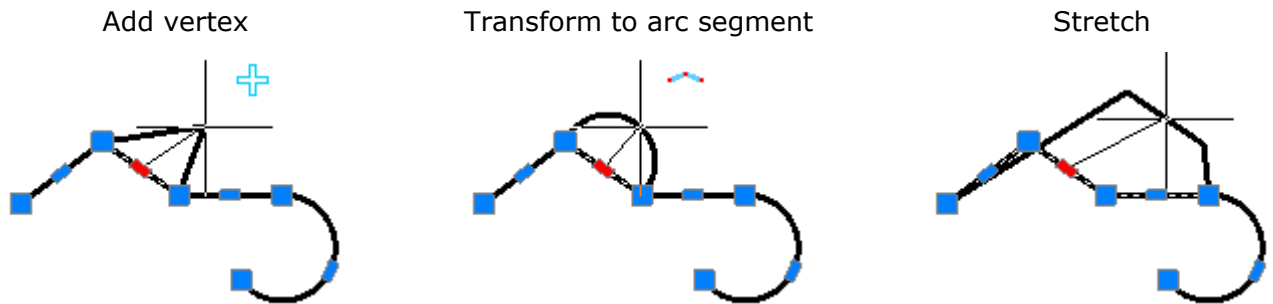

*Variants of polyline editing with grips in the middle of an arc segment:*

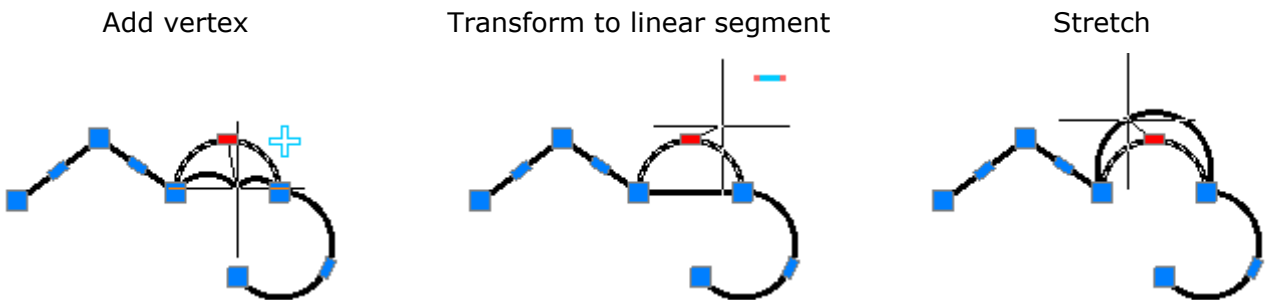

A multifunctional mode for editing polylines can be applied to several grips located in vertexes. Two editing variants are available: normal stretching of the polyline and deleting of selected vertexes. Instead of deleted vertexes, a linear segment is drawn, even if arc segments are between the deleted vertexes.



*To edit several vertices of a polyline using multifunctional grips:*

1. Press **SHIFT**.

2. Select the required grips with **SHIFT** pressed.
3. When you finish selecting grips, release **SHIFT**.
4. Select a base grip.
5. Select an editing mode with **CTRL**.
6. Move the cursor for dynamic display of the polyline shape.
7. Click to fix changes.

## Spline Editing

Spline has two edit modes using grips:

- *Editing fit points* (rectangular grips) that allows you to change the shape of a small part of a spline.
- *Editing control vertices* (round grips) that allows you to change the entire spline shape.

To switch between modes, click by a left mouse button on the round grip located near the spline and having a bigger diameter than the grips of control vertices.

Grips of fit points

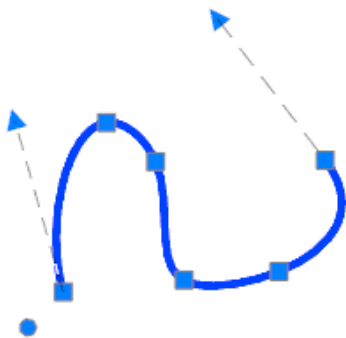

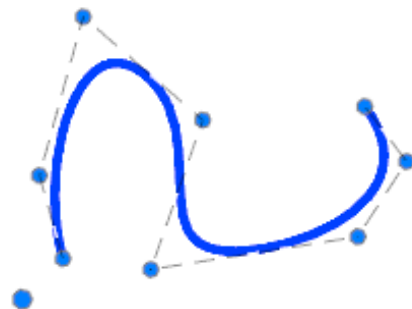

Grips of control vertices



In the mode of editing fit points, multifunctional grips are available with iteration by **CTRL** key.

Next to the cursor, conventional icons are additionally highlighted, their appearance depends on the selected edit mode:

-  Adds a vertex.
-  Deletes a vertex.

The absence of a conventional icon indicates that the current mode is a common mode of grips editing – stretching by moving a segment or stretching with a vertex (depending on the selected grip).

Options for spline editing using a grip located in the vertex:

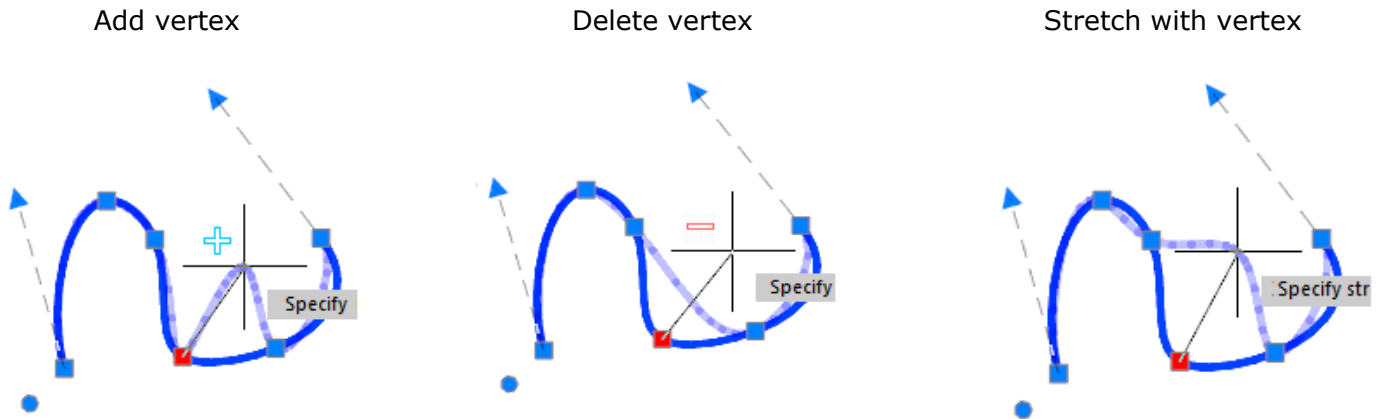



## Editing 3D-Polyline

To edit 3D-polylines, use multifunctional grips located in vertices.

The edit modes proposed when cycling through by **CTRL** key depend on the place handles are located (top or middle of a segment).

Next to the cursor, conventional icons are additionally highlighted, their appearance depends on the selected edit mode:

-  Adds a vertex.
-  Deletes a vertex.

The absence of a conventional icon indicates that the current mode is a common mode of grips editing – stretching by moving a segment or stretching with a vertex (depending on the selected grip).

Options for editing 3D-polyline using a grip located in the vertex:

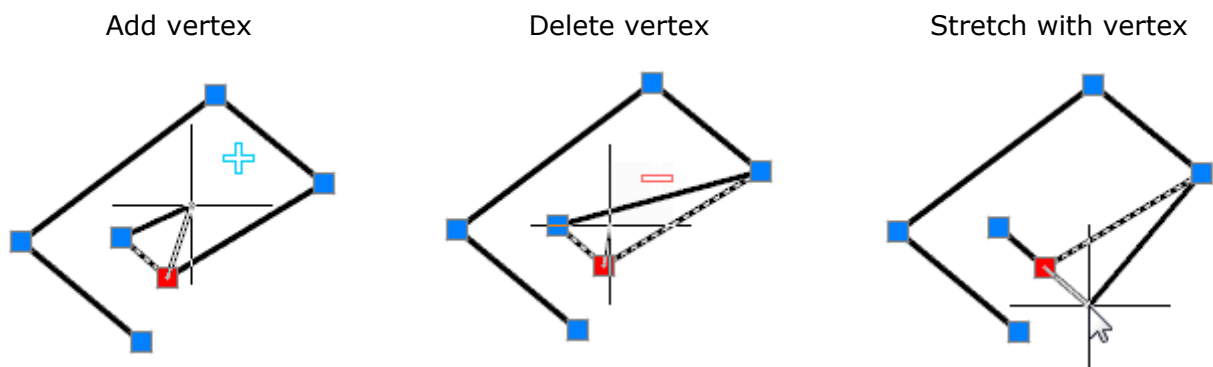

For 3D polylines multifunctional edit mode can be used for several grips located in vertices. Two editing options are available: common stretching a polyline or deleting selected vertices. A line segment is always drawn instead of deleted vertices.



Stretching vertices

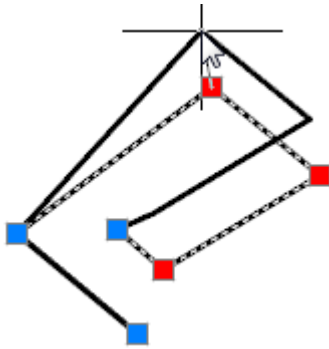

Deleting vertices

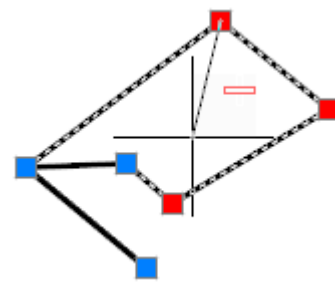

**To edit several vertices of 3D polyline using multifunctional grips:**

1. Press the **SHIFT** key.
2. Select the required grips holding down the **SHIFT** key.
3. After the grip selection is completed, release the **SHIFT** key.
4. Select the base grip.
5. Select the edit mode by the **CTRL** key.
6. Move the cursor for dynamic display of the change of polyline change.
7. Left-click to fix the changes.

## Editing Viewports in Paper Space

You can edit any viewports in paper space using multifunctional grips where closed polylines and splines are used as boundaries. The process of editing the boundaries of the viewport is the same as editing of a spline or polyline with multifunctional grips.

As viewports consist of two objects (viewport and display border), to edit them in the Selection dialog box select a polyline or spline, not a viewport:

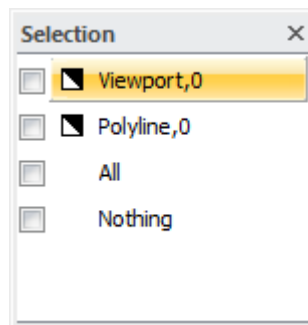

If display of the **Selection** dialog box is switched off, select a polyline or spline in the **Properties** panel in the **Object type** field:

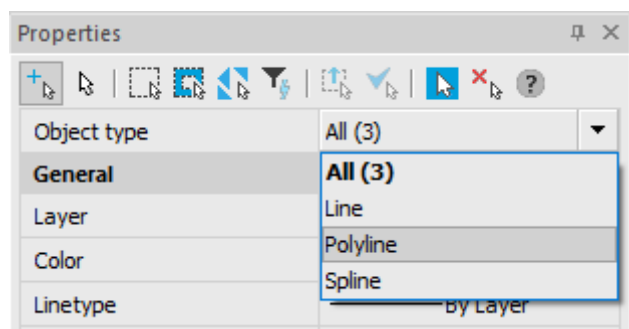

Select a viewport with a window or crossing window, if you select with the pickbox in the **Object type** field in the **Properties** panel, **Viewport is** displayed by default.

## *Editing Hatch and Fill*

In nanoCAD, using multifunctional grips you can edit the shape of:

- *associative hatches*, which use closed polylines and splines as linked contours;
- *non-associative hatches*.

Changing the shape of an *associative* hatch using multifunctional grips and a linked contour does not differ from the editing of a polyline or spline using multifunctional grips.

If you select *non-associative* hatch, the same multifunctional grips are displayed as in a polyline, except the round grips are used to move the hatch:

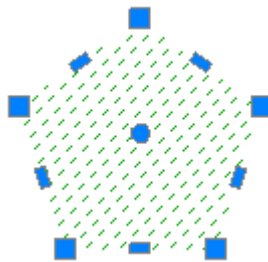

The process of editing a non-associative hatch shape is the same as editing of a polyline with multifunctional grips.

*Variants of non-associative hatch shape editing with grips in a boundary vertex:*

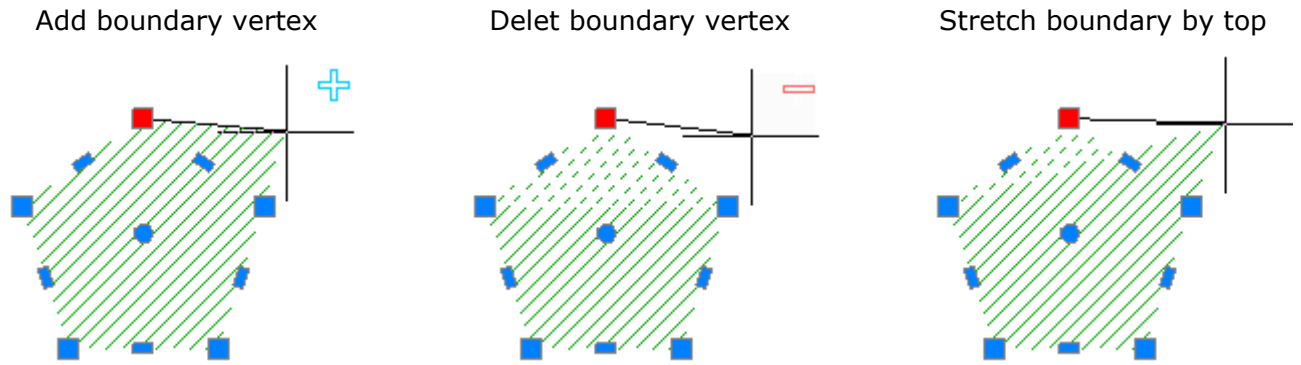

*Variants of non-associative hatch shape editing with a grip in the middle of a boundary linear segment:*

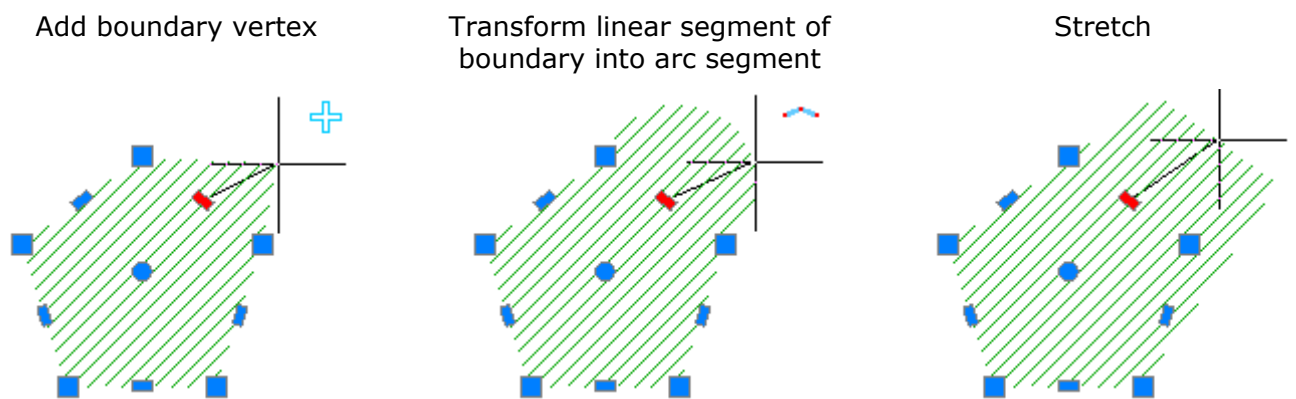

*Variants of non-associative hatch shape editing with a grip in the middle of a boundary arc segment:*

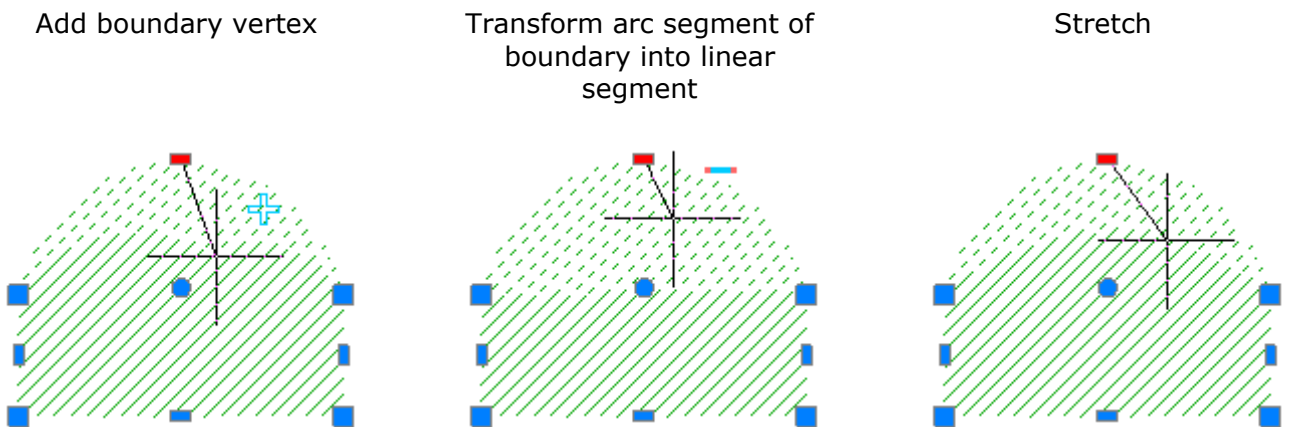

For non-associative hatch, a multifunctional editing mode can be applied to several grips located in the boundary vertexes. Two variants of editing are available: normal stretching of boundary and deleting of selected vertexes. Instead of deleted vertexes a linear segment is drawn, even if arc segments were between deleted vertexes.

Stretch boundary vertexes

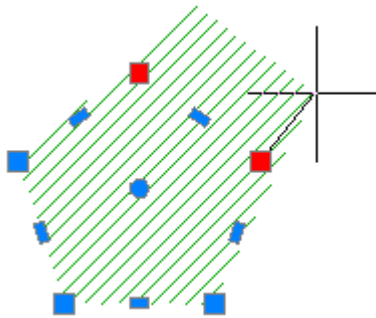

Delete boundary vertexes

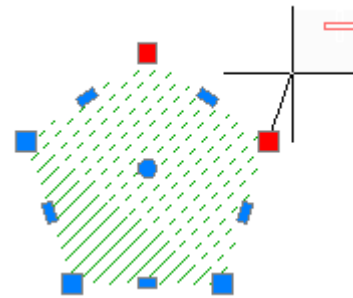

*To edit several vertexes of non-associative hatch area using multifunctional grips:*

1. Press **SHIFT**.
2. Select the required grips with **SHIFT** pressed.
3. When you have selected the grips, release **SHIFT**.
4. Select a base grip.
5. Select an editing mode with **CTRL**.
6. Move the cursor for dynamic display of the hatch shape.
7. Click to fix changes.

## Editing Polyline Segments

You can select individual segments of the **Polyline** object by holding down the **CTRL** key (or **SHIFT**+**CTRL** depending on the selection mode). Selected segments have functional grips that can be used to edit them.

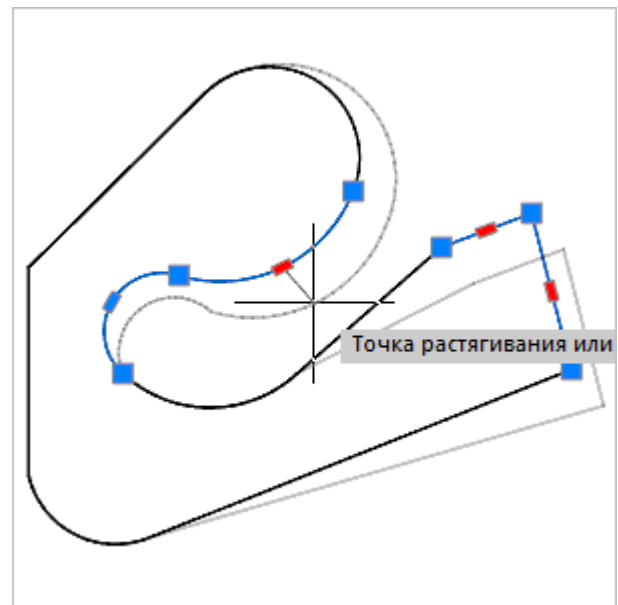
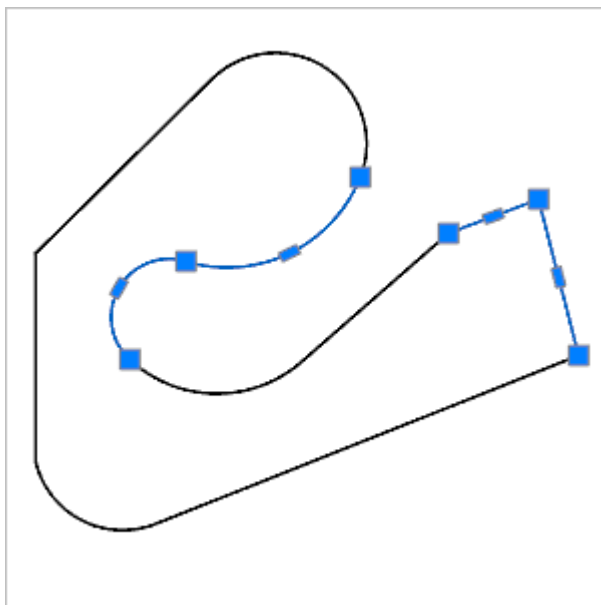





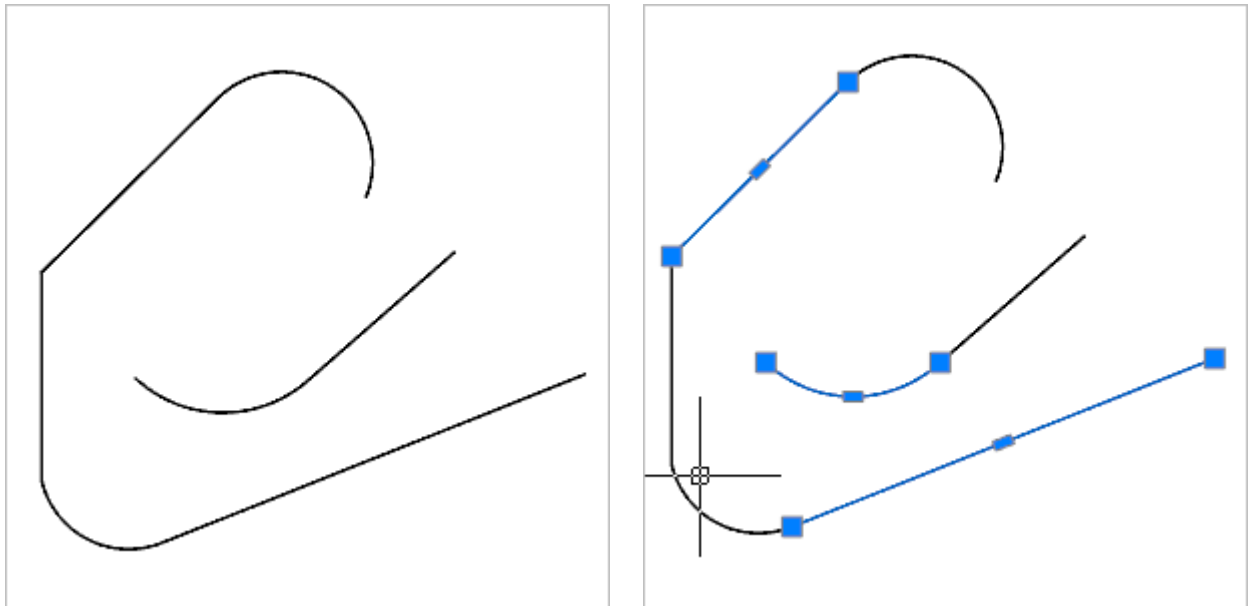





The selected segments can be moved, rotated and scaled with standard **Move** (MOVE), **Rotate** (ROTATE) and **Scale** (SCALE) editing commands.

You can delete such segments, including internal ones, with the formation of remaining polyline objects.



## Commands to Edit Objects Geometry

### Lengthen Objects

-  Ribbon: **Home, Draw - Modify** >  **Lengthen objects**
-  Ribbon: **Home, Draw - Modify** >  **Delta**
-  Ribbon: **Home, Draw - Modufy** >  **Dynamic**
-  Menu: **Modify** –  **Lengthen objects**
-  Toolbar: **Edit** – 



Command line: **LEN, LENGTHEN**

Using the **Lengthen** command you can change the central angle of arcs and the length of lines, arcs and open polylines. The length or angle of objects is changed on the side closest to the specified point or on both sides simultaneously. The length or angle of the same object can be changed several times whilst one command is being performed. If a value is positive, the arc is lengthened, if a value is negative – the arc is shortened.

#### Command options:

? Opens the additional options to select objects.

DElta The value of the object's length is changed.  
The option opens the prompt in the command line:

Enter delta length or [Angle]:

#### **Option:**

Angle-The value of the object's center angle is changed.

Percent The object's length as a percentage of the source length.

Total The total length or center angle.  
The option opens the prompt in the command line:  
Enter total length or [Angle]:

**Option:**

Angle-The value of the object's center angle is changed.

DYnamic Dynamic change of the selected object's length by replacing the endpoint closest to the selection point with the fixed position of another endpoint.

Selection of object



Specifying a new length

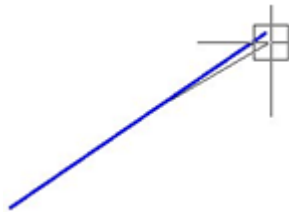

Result

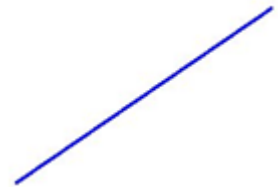

Close Closing arcs and elliptical arcs.

Bothends Lengthening an objects in two ends simultaneously (symmetrically).

ONEend Lengthening and object in one end closest to the specified point.

**Command prompts:**

Select objects  
or[?/DElta/Perce<sup>n</sup>t/Total/DYnamic]:  
Select an object to change or [?]:  
Specify new endpoint:  
Select an object to change or [?]:

Select the DYnamic.  
Specify an object.  
Specify a new length of the object.  
Specify an object or press **ESC** to finish the command.

The DElta and DYnamic command options can be run by buttons of the ribbon and the **Modify** toolbar:

 Ribbon: **Home, Draw - Modify >**  **Delta**

 Ribbon: **Home, Draw - Modify >**  **Dynamic**

**Trim Vectors**

 Ribbon: **Home, Draw - Modify >**  **Trim Vectors by Edge**

 Menu: **Modify -**  **Trim vectors**

 Toolbar: **Modify -** 



Command line: **TR, TRIM, VCTRIMBYEDGECMD**

The **Trim vectors** command allows the trimming of vector objects by their boundaries (or boundary edges), specified for one or several objects. Objects not intersecting with boundary edges can be cut at the point of their imaginary intersection. One object can be a boundary edge and a cut object.

If you press **ENTER** in the command prompt *Select objects or [?]:*, all existing objects are transformed into boundary edges. When you select object to be cut, nearest objects are selected as edges.

You can trim objects without closing the command. Press **SHIFT** when you are selecting objects.

### **Command options:**

- ? Opens the additional options to select objects.
  
- Fence Selection of objects by a crossing line which can consist of several segments.
  
- Crossing Selection of objects with a crossing frame.
  
- Project Mode for cutting objects by intersection of their projections with the boundary in 3D space.  
 The option opens the prompt in the command line:  
 Enter a projection option [None/Ucs/View/] <None>:  
**Options:**  
None Only objects that are crossed by the specified boundary in 3D space are selected.  
Ucs Defines the projections of objects in the XY plane of the current UCS and cuts objects which are not intersected by the boundary in 3D space.  
View Defines the projections of objects in the direction of the specified view and cuts objects which are not intersected by the edge.
  
- Edge Specifies the cutting mode of objects by imaginary extension of the edge.  
 The option opens the prompt in the command line:  
 Enter an implied edge extension mode [No extend/ Extend] <No extend>:  
**Options:**  
No extend Switches off the cutting of objects by imaginary extension of the edge.  
Extend Switches on the cutting of objects by imaginary extension of the edge.
  
- eRase Deletes the selected objects.
  
- Back Cancels the last change executed during performance of the command.

### Selection of edge

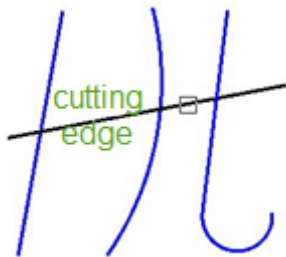

### Selection of object with pickbox

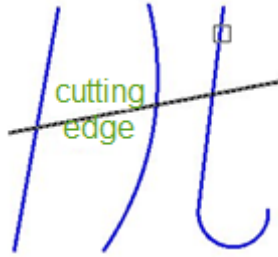

### Selection of objects with crossing frame

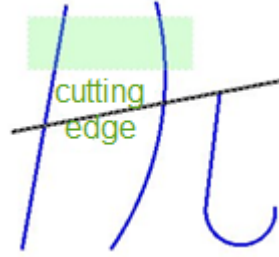

### Result

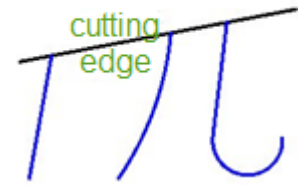

#### Command prompts:

Select objects or [?]:

Select an object which will be used as the cutting object.

Select object or [?]:

Select the next object or press **ENTER** to select the objects to be cut.

Select object to trim or [?/Fence/Crossing/Project/Edge/eRase/Back]:

Select an object.

Select object to trim or [?/Fence/Crossing/Project/Edge/eRase/Back]:

Select the next object or press **ENTER** to finish the command.

## Smart Trim



Ribbon: **Draw - Modify** >  **Smart Trim**



Menu: **Modify** -  **Smart trim**



Toolbar: **Modify** - 



Command line: **SMARTTRIM**

The **Smart trim** command differs from the **Trim vectors** in automatically selecting all vector objects in the document as potential cutting edges. Selected objects are cut to the nearest cutting edges.

#### Command options:

? Opens the additional options to select objects.

Fence Selection of objects by a crossing line which can consist of several segments.

Crossing Selection of objects with a crossing frame.

Project Mode of cutting objects by intersection of their projections with the boundary in 3D space.



The option opens the prompt in the command line:

Enter a projection option [None/Ucs/View/] <None>:

**Options:**

None Only objects that are crossed by the specified boundary in 3D space are selected .

Ucs Defines the projections of objects in the XY plane of the current UCS and cuts objects which are not intersected by the boundary in 3D space.

View Defines the projections of objects in the direction of the specified view and cuts objects which are not intersected by the edge.

Edge Specifies the cutting mode of objects by imaginary extension of the edge.

The option opens the prompt in the command line:

Enter an implied edge extension mode [No extend/Extend] <No extend>:

**Options:**

No extend Switches off the cutting of objects by imaginary extension of the edge.

Extend Switches on the cutting of objects by imaginary extension of the edge.

eRase Deletes the selected objects.

Back Cancels the last change executed during performance of the command.

**Command prompts:**

Select object to trim or

[?/Fence/Crossing/Project/Edge/eRase/Back]: Select objects to be cut.

Select object to trim or

[?/Fence/Crossing/Project/Edge/eRase/Back]: Select eRase.

Select objects to erase or [?]:

Select objects and press **ENTER** to delete them.

Select object to trim or

[?/Fence/Crossing/Project/Edge/eRase/Back]: Select Back to cancel deleting.

Select object to trim or

[?/Fence/Crossing/Project/Edge/eRase/Back]: Press **ENTER** to finish the command.

## Extend Vectors



Ribbon: **Home, Draw - Modify** >  **Extend Vectors by Edge**



Menu: **Modify** –  **Extend vectors**



Toolbar: **Modify** – 



Command line: **EX, EXTEND, VCEXPANDBYEDGECMD**

The **Extend** command extends vector objects to their real or imaginary crossing with other objects, called **boundaries** or **boundary edges**. Extended objects are selected by specifying an extended part.

When several boundaries are specified, the object is extended to the nearest one. The object can be selected again to extend it to the next boundary edge.

If you press **ENTER** in the command prompt *Select objects or [?]:*, all existing objects are transformed into boundary edges. When you select object to be lengthen, nearest objects are selected as boundary edges.

You can cut objects without closing the command. Press **SHIFT** when you are selecting objects.

### Command options:

**?**

Opens the additional options to select objects.

**Fence**

Selection of objects by a crossing line which can consist of several segments.

**Crossing**

Selection of objects with a crossing frame.

**Project**

Mode of extending objects by intersection of their projections with the boundary in 3D space.

The option opens the prompt in the command line:

Enter a projection option [None/Ucs/View/] <None>:

#### Options:

**None** Only objects that are crossed by the specified boundary in 3D space are selected

**Ucs** Defines the projections of objects in the XY plane of the current UCS and cuts objects which are not intersected by the boundary in 3D space.

**View** Defines the projections of objects in the direction of the specified view and cuts objects which are not intersected by the edge.

**Edge**

Specifies the extending mode of objects by imaginary extension of the edge.

The option opens the prompt in the command line:

Enter an implied edge extension mode [No extend/Extend] <No extend>:

#### Options:

**No extend** Switches off the cutting of objects by imaginary extension of the edge.

Extend Switches on the cutting of objects by imaginary extension of the edge.

Delete Deletes selected objects.

Back Cancels the last change executed during performance of the command.

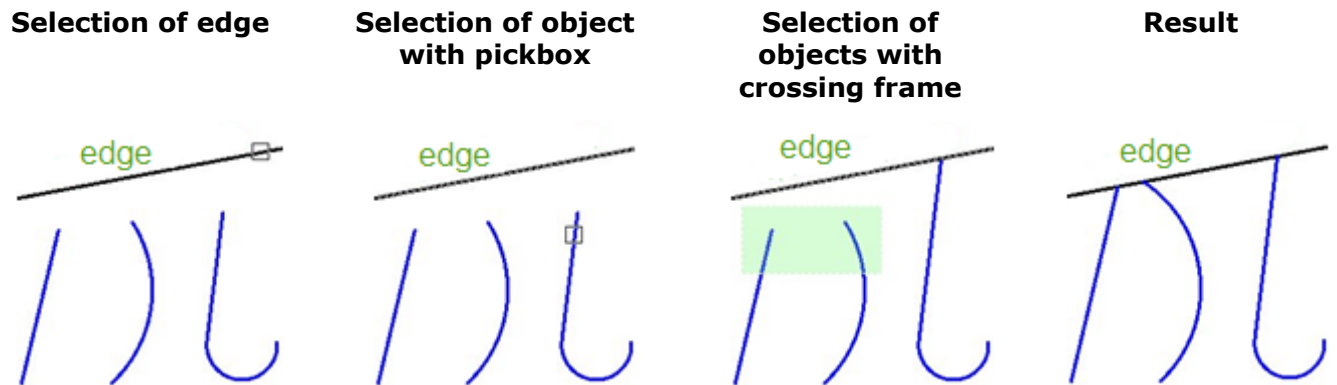

**Command prompts:**

Select objects or [?]:

Select the object that is to be used as the edge.

Select objects or [?]:

Select next object or press **ENTER** to start selecting objects to extend.

Select object to extend or

[?/Fence/Crossing/Project/Edge/Delete/Back]:

Select an object.

Select object to extend or

[?/Fence/Crossing/Project/Edge/Delete/Back]:

Select Crossing and select other objects. Press **ENTER** to finish the command.

## Break Vectors



Ribbon: **Home, Draw - Modify** >  **Break Vectors**



Menu: **Modify** -  **Break vectors**



Toolbar: **Modify** - 



Command line: **BREAK, BR, VCBREAKCMD**

The **Break vectors** command breaks lines, arcs, circles, polylines, ellipses, splines and other vector objects into two parts. A break can be performed by deletion of a part of it (breaking of the object at two points) or without deletion (breaking of the object at one point). Some closed objects for example, circle, ellipse, cannot be broken in one point.

To break an object at one point, at the command prompt to enter the second point, enter @0,0:

Specify second break point or [First point]: @0,0

**Command options:**

? Opens the additional options to select objects.

First point Switches to the mode of first point selection.

### Break of Object in Two Points

The part of the object between the specified points will be deleted. By default, the selection point of the object is the first point of the break. To specify another point as the first point, select the **First point** option.

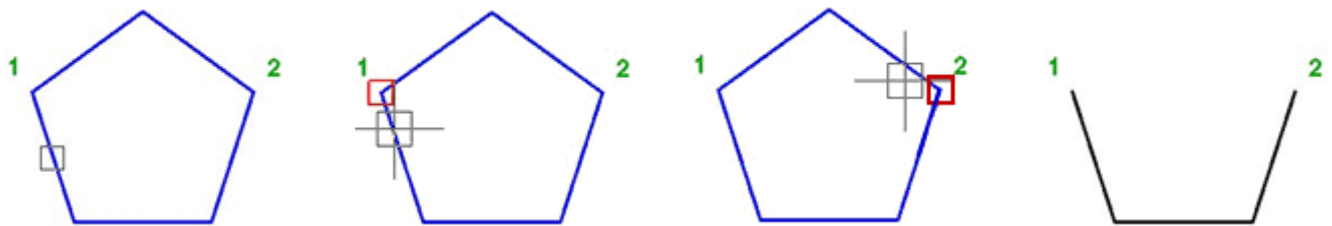

**Command prompts:**

Select objects or [?]:

Select an object.

Specify second break point or [First point]:

Select First point.

Specify first break point:

Specify point 1.

Specify second break point:

Specify point 2.

### Break of Object in One Point

Specify the same point as the first and the second points of the break.

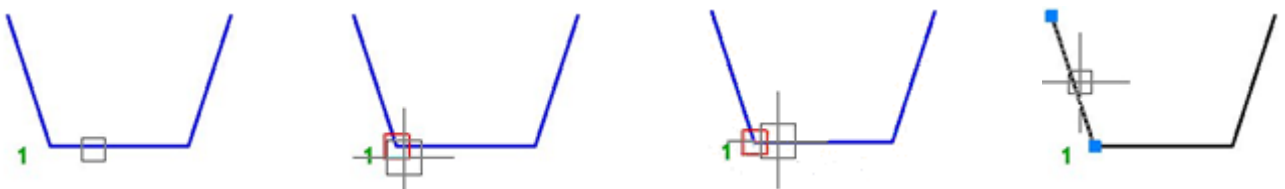

**Command prompts:**

Select objects or [?]:

Select an object.

Specify second break point or [First point]:

Select First point.

Specify first break point:

Specify point 1.



Specify second break point:

Specify again point 1.

## Break Vectors at Point

 Ribbon: **Home, Draw - Modify** >  **Break at Point**

 Menu: **Modify – Break vectors at point** 

 Toolbar: **Modify –** 

 Command line: **VCBREAKATPOINTCMD**

The **Break vectors at point** command breaks lines, arcs, circles, polylines, ellipses, splines and other vector objects into two parts at one point (without deleting part of the object). Some closed objects for example, circle, ellipse cannot be broken in one point.

### Command options:

? Opens the additional options to select objects.

### Command prompts:

Select objects or [?]: Select object.

Specify break point: Specify a point.

## Break All Vectors at Point *Break All Vectors at Point*

 Ribbon: **Draw - Modify** >  **Break All Objects at Point**

 Menu: **Modify – Break All Vectors at Point** 

 Toolbar: **Modify –** 

 Command line: **VCBREAKALLATPOINTCMD**

The **Break All Vectors at Point** command breaks intersection objects (lines, arcs, polylines, splines and other vector objects) in the intersection point. Some closed objects (ellipse, circle, etc.) can't be break at point.

Command options:

? Opens the additional options to select objects.

Command prompts:

Select objects or [?]: Select intersection object.

Specify break point: Specify an intersection point (s).

## Reverse

 Ribbon: **Home, Draw - Modify** >  **Reverse direction**

Menu: **Modify –**  **Reverse**



Command line: **REVERSE, FLIP**

This command is used to change the order of the vertexes of segments, polylines and splines.

For example, a segment with  $0,0$  coordinates for the start point and  $100,100$  for the end point will have  $100,100$  coordinates for the start point and  $0,0$  for the end point after the direction is changed.

#### Command options:

**?** Opens the additional options to select objects.

#### Command prompts:

Select object to Select an object.  
flip or [?]

Select object to Press **ENTER** to finish the command.  
flip or [?]

Select object to Press **ENTER** to close the command.  
flip or [?]

## Join Objects



Ribbon: **Home, Draw - Modify** >  **Join**



Menu: **Modify** -  **Join objects**



Toolbar: **Modify** - 



Command line: **JOIN**

The **Join objects** command joins separate segments of objects into one object. The command can be applied to segments, arcs and open polylines. The command can be applied to segments, arcs, open polylines, elliptical arcs, open splines and helixes. The resulting object type depends on types of selected objects, type of object selected as the source one, as well as coplanarity of objects.

Pre-selection of objects is allowed.

**NOTE.** Construction lines, rays and closed objects cannot be connected.

#### Command prompts:

Select line, arc, elliptical arc, open polyline, open spline or helix to join to source or [?]:

To select lines, polylines, arcs, elliptical arcs, helixes or splines.

After selecting a source object, press

**ENTER.**

Specify objects to join.

Further command prompts depend on the choice of the *source object* or *several objects* at once to join.

#### Source object

Specifies one source object to which other objects will join.

Additional restrictions for joined objects types:

<b>Line segments</b>	Must lie on the same line. There can be gaps between segments.
<b>Polylines</b>	Lines, polylines and arcs can be joined to a polyline. Objects must lie in one plane. Parallel to the XY plane of the UCS. There must be gaps between objects.
<b>Arcs</b>	Objects must lie in one imaginary circle. There can be gaps between arcs.
<b>Elliptic arcs</b>	Objects must lie in one imaginary ellipse. There can be gaps between arcs.
<b>Helix</b>	Any linear or arc object can be joined to the source helix. All objects must be contiguous, but can be non-coplanar. The resulting object is one spline.
<b>Spline</b>	Any linear or arc object can be joined to the source spline. All objects must be contiguous, but can be non-coplanar. The resulting object is one spline.

**Example. Connecting arcs with selecting the source object:**

*Command options:*

? Opens the additional options to select objects.

Close it Transforms an arc to a circle.

*Command prompts:*

Select source object or [?]:

Specify the first arc.

Select arcs to join to source or [?/Close it]:

Specify the second arc.

Select arcs to join to source or [?/Close it]:

Press **ENTER** to finish the command.

**Selection of first arc**

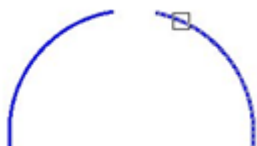

**Selection of second arc**

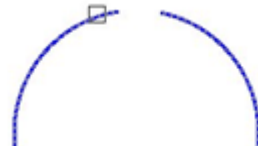

**Result**



**Multiple objects to join**

Joins multiple objects without specifying the source object.

When selecting multiple objects of different type to join, the resulting object will be the one with the most complex type.

So, when you apply the command to the selected lines and polylines, the result will be a single polyline. If the selection includes a polyline, line and spline, the resulting object will be a spline.

The creation rules and types of resulting objects are the following:

<b>Line object</b>	Created by joining collinear lines. Lines can have gaps between the endpoints.
<b>Arc or circular object</b>	Created from joining coplanar arcs with the same center point and radius. Arcs can have gaps between the endpoints. Lengthening is made in the counterclockwise direction. A circular object is created if joined arcs form a complete circle.
<b>Spline</b>	Created as a result of joining splines, elliptical arcs or helixes together or to other objects. The objects can be noncoplanar.
<b>Polyline</b>	Created as a result of joining coplanar lines, arcs, polylines.

## Editing a Polyline



Ribbon: **Home, Draw - Modify** >  **Edit Polylines**



Menu: **Modify - Object** >  **Polyline**



Toolbar: **Modify object** - 



Command line: **PE, PEDIT**



Double clicking on a polyline starts the editing mode.

Using the **Polyline** command you can edit polylines and also convert elementary objects, consisting of arcs and lines, into polylines.

### Command options:



Opens the additional options to select objects.

### Multiple

Selection of several objects mode.

### Close

Closes (draws a segment from start to end vertex) a polyline.

### Open

Opens a polyline (deletes a segment from start to end vertex).

### Edit vertex

Switches to the editing of vertexes mode (edited vertex is marked with "X" label).

The option starts the following prompt in the command line:

```
Enter          a          vertex          editing          option
[Next/Previous/Break/Insert/Move/Regen/Straighten/
Tangent/Width/Exit/] <N>
```

Next - Goes to the next vertex.

Previous- Goes to the previous vertex.

Break- Breaks a polyline at the selected vertex.

Insert- Adds a vertex in the specified place.

Move- Changes the position of the selected vertex.

Regen- Regenerates a polyline.



Straighten- Changes a line segment to an arc segment.

Tangent- Specifies the direction of the tangent in the selected vertex for further polyline fitting.

Width- Specifies the first and second width of the segment, going after the selected vertex.

Exit- Closes the editing of vertexes mode.

Join Joins segments, arcs and polylines into one object – polyline.

The option starts the following prompt in the command line:

Select polyline or [?/End]:

**Option:**

End- Closes selection of objects.

Width Specifies a new width for all polylines.

Fit Fits the polyline with arcs between polyline vertexes.

Spline Transforms a polyline into a spline which is an approximation of the source polyline between the start and end vertexes and is very similar to the source polyline.

Decurve Returns a polyline to its original condition, cancels the results of the Fit or Spline commands.

Ltype\_gen Specifies a mode of the specified line type generation.

The option starts the following prompt in the command line:

Enter polyline linetype generator option [ON/OFF/] <Off>:

If Off option is selected, generation of line type starts from dash and end dash in very vertex.

rEverse Changes the order of vertexes to the opposite.

The option is used to reverse the direction of objects that use linetypes with included text. For example, in accordance with the direction in which polyline was created, text for this linetype can be displayed inverted.

Undo Cancels the last action of polyline editing.

**Command prompts when selecting a polyline:**

Select polyline or [?/Multiple]:

Select Multiple.

Select polyline or [?/Multiple]:

Select objects.

Do you want to turn it into one? [Yes/No] <Y>:

Press **ENTER** or select No.

Enter an option [Close/Edit vertex/Join/Width/Fit/Spline/Decurve/Ltype\_gen/Undo]:

Select the required option. Press **ENTER** to finish the command.

### Command prompts to convert an object to a polyline:

Select polyline or [?/Multiple]:

Object selected is not a polyline. Do you want to turn it into one? [Yes/No/]<Y>:

Specify a tolerance <10>:

Enter an option  
[Close/Edit vertex/Join/Width/Fit/Spline/Decurve/Ltype\_gen/Reverse/Undo]:

Select an object (line, arc, spline).

Press **ENTER** or select Yes option. If you need to undo the selection, specify No.

When selecting a spline, enter the tolerance value to convert or press **ENTER**.

Select an option necessary for editing.

Upon completion of editing, press **ENTER** to end the command.

### Command prompts when selecting multiple objects:

Select polyline or [?/Multiple]:

Select objects [?/End]:

Select objects [?/End]:

Convert Lines, Arcs and Splines to polylines? [yes/No] <Y>:

Enter an option  
[Close/Edit vertex/Join/Width/Fit/Spline/Decurve/Ltype\_gen/Reverse/Undo]:

Select the Multiple option.

Select objects.

Select the End option.

Press **ENTER** or select Yes. If you need to undo the selection, specify No.

Select an option necessary for editing.

Upon completion of editing, press **ENTER** to end the command.

## Editing a Spline

 Ribbon: **Home, Draw - Modify** >  **Edit Splines**

 Menu: **Modify – Object** >  **Spline**

 Toolbar: **Modify Object** – 

 Command line: **SPE, SPLINEDIT**

Double clicking on a spline starts the editing mode.

This command allows changing of a spline's shape by adding, deleting or replacing characteristic points, changing the direction of tangents at the start and end points of the spline. Using this command, you can close or open a spline, change a tolerance value. A tolerance defines the maximum distance from the real spline to any of its characteristic points. The smaller the value a tolerance has, the closer the spline is to the characteristic points.

### Command options:

? Opens the additional options to select objects.

Fit data Switches to the editing of spline data mode, including tolerance values.

The option starts the following prompt in the command line:

Enter an option [Add/Close/Delete/Move/Purge/Tangents/Tolerance/Exit/] <Exit>:

**Options:**

Add - Adds characteristic points to the spline

Close/Open - Closes/Opens spline with fitting at a join point.

Delete - Deletes characteristic points from the spline and rebuilds the spline

Move - Changes the position of the previous point.

Purge - Deletes the spline data from the document database.

Tangents - Edits the start and end points of the spline.

tolerance - Specifies a new tolerance value.

eXit - Returns to the main prompt in the command line.

The Tangents option starts the following option in the command line:

Specify start tangent or [System default]:

**Option:**

System default - Sets tangents at the spline ends by default

- Close Closes an open spline with fitting at a join point.
- Open Opens a closed spline.
- Move vertex Changes the position of control vertexes and deletion of characteristic points.
- Refine Changes the spline's shape.  
The Refine options starts the following prompt in the command line:  
Enter a refine option [Add control point/Elevate order/Weight/Exit] <Exit>:  
**Options:**  
Add control point - Adds a control point near the point, selected on spline, between two control points.  
Elevate order -Increases the degree of the spline (increases the number of control points).  
Weight - Changes the weight factors at the control points of the spline (the greater the weight factor is, the closer the spline is to the control point).  
eXit - Returns to the main prompt in the command line.
- rEverse Changes the spline direction to the opposite (start and end points changes their places).

Exit Closes the spline editing mode.

The Move vertex and Weight of the **SPLINEDIT** starts the following prompts in the command line:

Specify new location or [Next/Previous/Select point/Exit/] <N>:

and

Specify new weight (current = 1.0000)<N> or [Next/Previous/Select point/Exit]:

**Options:**

<u>Next</u>	Selects the next point.
<u>Previous</u>	Selects the previous point.
<u>Select point</u>	Selects the control point.
<u>eXit</u>	Returns to the previous prompt in the command line.

**Command prompts:**

Select spline or [?]:	Select a spline.
Enter an option [ <u>Fit data/Close/Move vertex/ Refine/rEverse/Undo/eXit</u> ]:	Select the required option. To finish editing, select <u>Exit</u> option.

## Simplify Spline



Ribbon: **Main – Modify** >  **Simplify spline**



Menu: **Modify – Additional features** > 



Toolbar: **Modify 2** – 



Command line: **SIMPLIFYSPLINE**

Optimizes splines by managing accuracy of its approximation and specifying maximum number of fit points.

**Command prompts:**

Specify splines to simplify or [?]:	Select a spline.
Apply settings to splines or [ <u>tolerance (1.00e-009)/the maximum number of points (2000)</u> ]:	Select a required option.
<u>Enter tolerance &lt;1.00e-009&gt;:</u>	<u>Tolerance (1.00e-009)</u> – sets values of spline accuracy. Enter the value of tolerance in exponential format.
	<u>maximum number of points (2000)</u> –

sets maximum number of fit points.

Enter a required value

Enter the maximum number of fit points <2000>



## Commands to Edit and Replicate Objects

### Erase

 Ribbon: **Home, Draw - Modify** >  **Erase**

 Menu: **Modify** –  **Erase**

 Toolbar: **Modify** – 

 Toolbar: **Main** – 

 Command line: **E, ERASE, DELETE**

This command deletes objects from the document.

The **Erase** command is also available in the context menu.

Selected objects can be deleted by pressing the **DEL** button on the keyboard.

#### Command options:

**?** Opens the additional options to select objects.

#### Command prompts:

Select objects or **[?]**: Select objects.

Select objects or **[?]**: Continue selection of objects or press **ENTER** to finish the command.

### Copy

 Ribbon: **Home, Draw - Modify** >  **MoveCopy**

 Menu: **Modify** –  **Copy**

 Toolbar: **Modify** – 

 Hotkeys: **CTRL+SHIFT+D**

 Command line: **CO, COPY, CP, MOVECOPY**

This command can copy selected objects once or several times.

The **Displacement** option allows copying of objects by specifying a relative distance with coordinates. The coordinates define a displacement value for the objects being copied.

### Command options:

- ? Opens the additional options to select objects.
- Displacement Specifies a relative distance and direction with coordinates.
- Mode Changes the copy mode.  
The option starts the following prompt in the command line:  
Enter a copy mode option [Single/Multiple] <Multiple>:  
**Options:**  
Single - Single copy of objects.  
Multiple - Multiple copies of objects.
- Array Arranges a specified number of copies in a linear array.
- Exit Finishes the command in the multiple copy of objects mode.
- Undo Cancels the last action

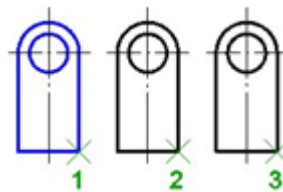

### Command prompts:

- Select objects or [?]: Select objects. Press **ENTER** when the selection is finished.
- Specify base point or [Displacement/moDe] <Displacement>: Specify 1 base point.
- Specify second point or [Array] <use first point as displacement>: Specify second point.
- Specify second point or [Array/Exit/Undo] <Exit>: In Multiple copy mode, specify end point 3. Press **ENTER** to finish the command.

### Command prompts for Array option

- Select objects or [?]: Select objects.  
Press **ENTER** when the selection is finished.
- Specify base point or [Displacement/moDe] <Displacement>: Specify base point.
- Specify second point or [Array] <use first point as displacement>: Select Array option.
- Number of elements in array: Enter the number of elements.
- Specify second point or [Fit]: Select required option.

The distribution of elements in the array depends on selection of Specify second point or Fit:

**Second point** - Determines a distance and direction for the array relative to the base point. The first copy in the array is positioned at the specified displacement. The remaining copies are positioned in a linear array beyond that point using the same incremental displacement

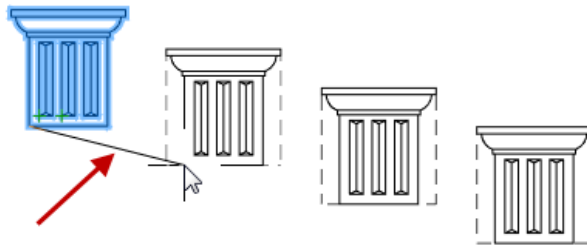

**Fit** - positions the final copy in the array (not the first one) at the specified displacement. The other copies are fit in a linear array between the original selection set and the final copy.

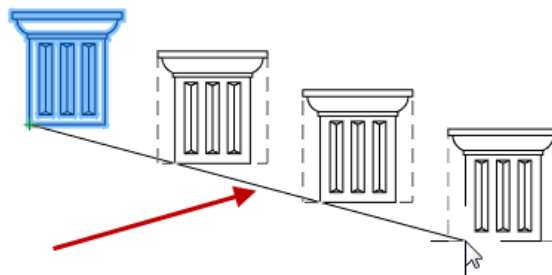

The **SHOWMODIFYFRAME** system variable is intended to control the visibility of the dotted frame around selected objects during editing operations (copying, moving, etc.). When the system variable is set to *1*, the cropping path box is displayed on the screen (default). A system variable value of *0* disables frame visibility.

## Mirror



Ribbon: **Home, Draw - Modify** >  **Mirror Objects**



Menu: **Modify** -  **Mirror**



Toolbar: **Modify** - 



Command line: **MI, MIRROR**

This command creates mirror copies of objects along the specified axis.

Using this command, you can quickly create symmetrical objects, you just create one part of the object and the other part of the object is drawn by the command.

Mirrored texts, attributes and their definitions have a mirror view. For a normal view of text, set 0 value (default value) for the **MIRRTXT** system variable.

### Command options:

?

Opens the additional options to select objects.

Yes

Deletes source objects.

No

Source objects are not deleted.

### Selection of objects by frame



### Specifying the first point

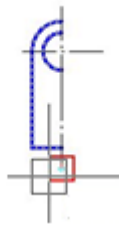

### Specifying the second point

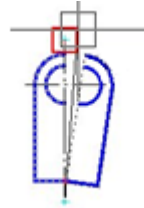

### Result

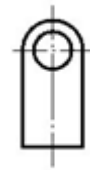

#### Command prompts:

Select objects or [?]:

Select objects. Press **ENTER** when the selection is finished.

Specify first point of mirror line:

Specify the first point.

Specify second point of mirror line:

Specify the second point.

Erase source objects? [Yes/No]  
<N>:

Select the No option.

## Offset



Ribbon: **Home, Draw - Modify** >  **Offset Object**



Menu: **Modify** -  **Offset**



Toolbar: **Modify** - 



Command line: **O, OFFSET, VCOFFSETCMD**

This command allows the creation of a new object similar to the selected one and is placed at the specified distance from it.

The **Offset** command is applicable to the following types of objects:

- line segment;
- arc;
- circle;
- ellipse and elliptical arc (as a result, splines of oval shapes are formed);
- two-dimensional polyline;
- line;
- ray.

Similarly, arcs and circles have diameters smaller or larger than the source objects, according to which side the offset was made.

If the **Multiple** option is selected, all similar objects are created with the current offset.

#### Command options:



? Opens the additional options to select objects.

Erase Erases the source objects after creating similar ones.  
 The option starts the following prompt in the command line:  
 Erase source objects after offsetting? [Yes/No] <No>:  
 Options:  
Yes - Deletes the source objects.  
No - Source objects are not deleted.

Layer Defines the layer of the source objects.  
 The option starts the following prompt in the command line:  
 Enter layer option for offset objects [Source/Current] <Current>:  
**Options:**  
Source - Creates similar objects on the source layer.  
Current - Creates similar objects on the current layer.

Multiple Switches on the mode for multiple creation of similar objects.

Undo Consecutive undo of previous actions.

Exit Finishes the command.

**Selection of object**

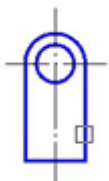

**Offset**

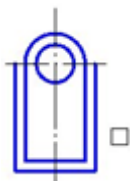

**Selection of object**

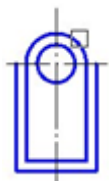

**Offset**

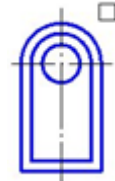

**Result**

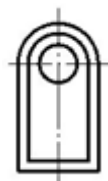

**Command prompts:**

Specify offset distance or [Erase/Layer] <10.0000>:

Select objects to offset or [?/Exit]:

Specify point on side to offset or [Exit/Multiple] <Exit>:

Select objects to offset or [?/Exit]:

Specify point on side to offset or [Exit/Multiple] <Exit>:

Select objects to offset or [?/Exit]:

Specify distance, entering it from the keyboard or specify on the screen.

Select an object.

Specify a point.

Select an object.

Specify a point.

Select the Exit option to finish the command.

## Arrays

This command is used to create two-dimensional arrays of the selected objects by placing their copies on the specified circle, in the nodes of the specified rectangular grid or along the trajectory.

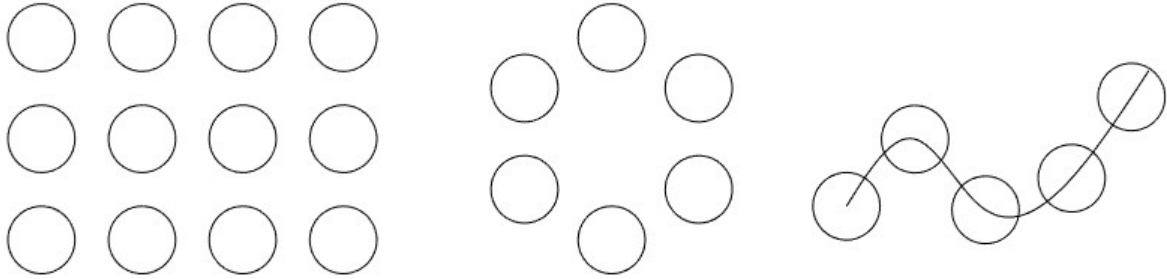

Each array object is called an *array element* and can consist of multiple objects. The source object of an array can be a block.

Arrays can be associative and non-associative (2D arrays, 3D arrays).

## Associative Arrays

Associativity allows you to quickly make changes in the entire array due to the established relationship between the elements, while all the elements of the associative array are perceived as a single object. In an associative array, you can change the number of elements and the distance between them, set the number of levels. You can control the parameters of an associative array using the array grips or **Properties** bar.

An associative array can be divided into separate objects by **Explode** command.

The **Associative** option of the commands for creating and editing arrays allows you to specify whether the arrays will be associative or non-associative. Associative array elements are selected, edited, and behave like a single dynamic block. Non-associative arrays, after the end of the command, decay into independent objects.

## Rectangular Array



Ribbon: **Home - Modify** >  **Rectangular Array**



Ribbon: **Draw - Modify** >  **Rectangular Array**



Menu: **Modify** -  **Rectangular Array**



Command line: **ARRAYRECT**

Arranged distribution of copies of objects in any combination of rows, columns, and levels.

### Creating an array:

1. Run the command.
2. Select objects to create an array, press **ENTER**.  
From this moment, a preview of the array based on the current values of its parameters will be displayed on the screen.

- In the Properties bar, in the command line, context menu or using a dynamic input, specify the array parameters.

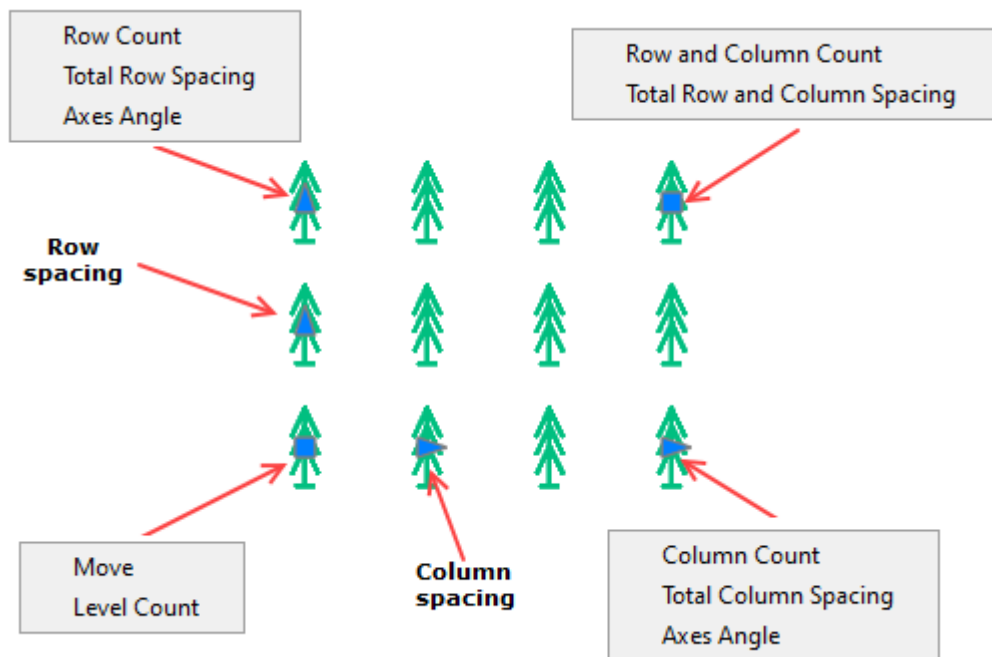

### Command prompts:

Select objects or [?]:

Selecting objects to be used in an array. The prompt appears if the objects were not preselected before the command starts.

Press **ENTER** upon the selection is completed.

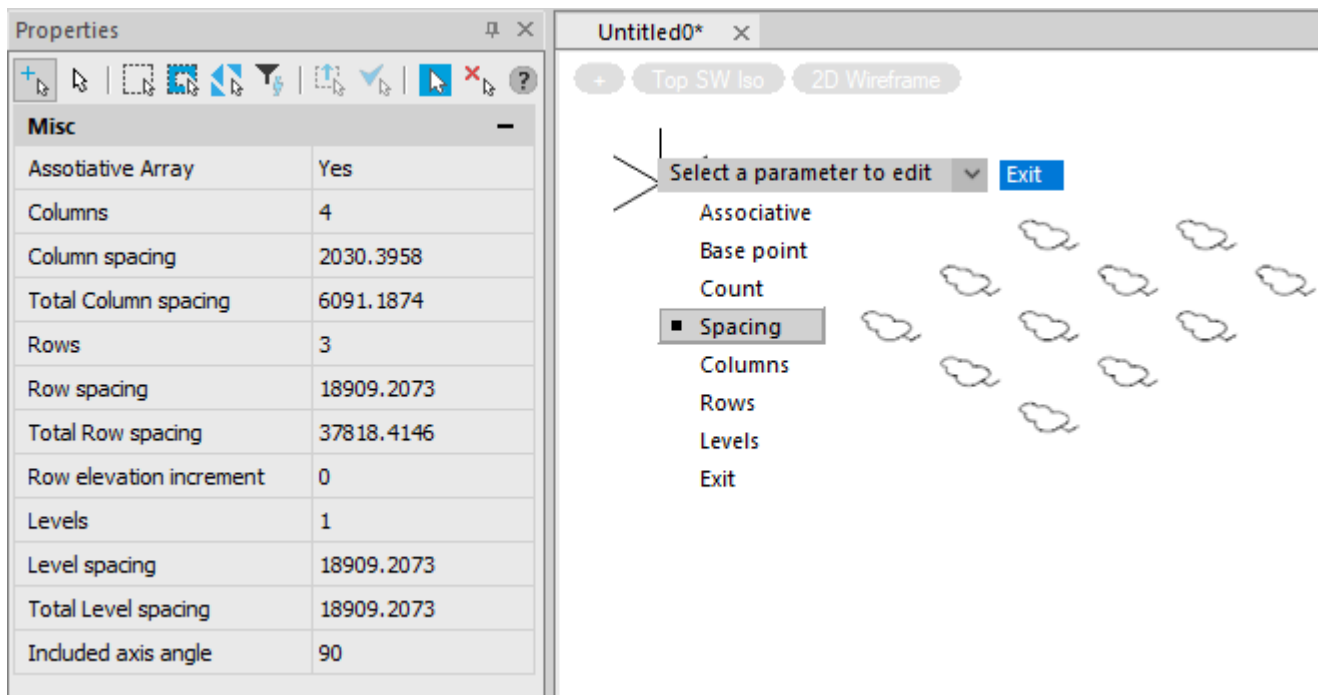

### Command options:

The command options can be edited in the **Properties** bar, in the dynamic input menu or in the command line.

**NOTE:** When specifying values in the dynamic input menu or command line, you should return to the **Properties** bar to display the actual values on it.

<u>Associative</u>	Determines whether array objects are associative or independent.
<u>Base point</u>	Determines the location of the array's base point.
<u>Count</u>	<p>Specifies the number of columns and rows in the array.</p> <p>The option initiates the following prompt in the command line:</p> <p style="padding-left: 20px;">Enter the number of columns:</p> <p style="padding-left: 20px;">Enter the number of rows:</p> <p>Identical to options <b>Columns</b> and <b>Rows</b> in the <b>Properties</b> bar.</p>
<u>Spacing</u>	<p>Specifies the spacing between rows and columns measured from identical points in array objects (for example, the spacing from the top of one object to the top of the second object).</p> <p>The option initiates the following prompt in the command line:</p> <p style="padding-left: 20px;">Specify the distance between columns [<u>Unit cell</u>]:</p> <p style="padding-left: 20px;">Specify the distance between rows:</p> <p>You can enter numerical values or measure distances on the screen.</p> <p><b>Options:</b></p> <p><u>Unit cell</u> - Determines the distance between rows and columns at the same time by specifying the start and end points of the rectangular area.</p> <p>Identical to options <b>Column spacing</b> and <b>Row spacing</b> in the <b>Properties</b> bar.</p>
<u>Columns</u>	<p>Sets the number of columns in the array and the spacing between them.</p> <p>The option initiates the following prompt in the command line:</p> <p style="padding-left: 20px;">Enter the number of columns:</p> <p style="padding-left: 20px;">Specify the distance between columns [<u>Total</u>]:</p> <p>You can enter numerical values or measure distances on the screen.</p> <p><b>Options:</b></p> <p><u>Total</u> - Specifies the total distance between the start and end column measured from identical points on the start and end object.</p> <p>Identical to options <b>Columns</b> and <b>Column spacing, Total Column spacing</b> in the <b>Properties</b> bar.</p>
<u>Rows</u>	<p>Sets the number of rows in the array and the spacing between them.</p> <p>The option initiates the following prompt in the command line:</p> <p style="padding-left: 20px;">Enter the number of rows:</p> <p style="padding-left: 20px;">Specify the distance between rows [<u>Total</u>]:</p> <p style="padding-left: 20px;">Specify the incrementing elevation between rows:</p> <p>Incrementing elevation between rows – the amount by which the distance between each successive row of objects increases or decreases. You can enter numerical values or measure distances on the screen.</p> <p><b>Options:</b></p> <p><u>Total</u> - Specifies the total distance between the start and end row measured from identical points on the start and end object.</p> <p>Identical to options <b>Rows, Row spacing, Total Row spacing</b> and <b>Row elevation increment</b> in the <b>Properties</b> bar.</p>
<u>Levels</u>	Sets the number of levels and the spacing between them for creating a

3D array.

The option initiates the following prompt in the command line:

Enter the number of levels:

Specify the distance between levels [Total]:

The distance between levels specifies the difference in Z coordinate values between the levels of objects. You can enter numerical values or measure distances on the screen.

**Options:**

Total - Specifies the Z distance between the start and end level measured between equivalent points on the first and last level objects.

Identical to options **Levels** and **Level spacing**, **Total Level spacing** in the **Properties** bar.

Axis angle

Allows you to create skewed patterns by changing the angle between the axis of columns and rows.

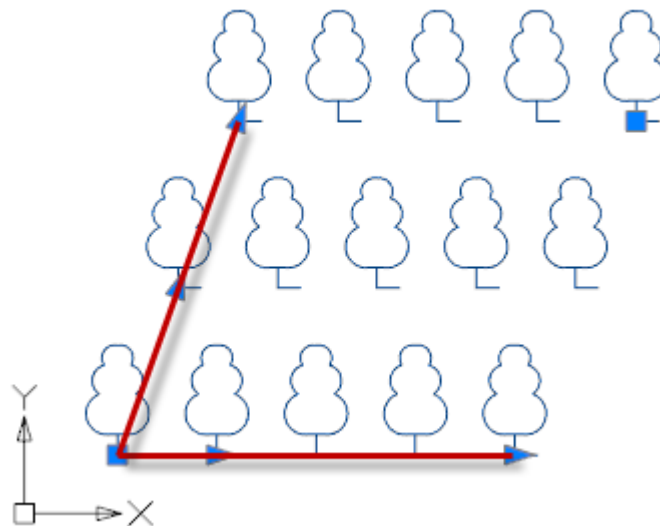

Exit

Completes creating the array.





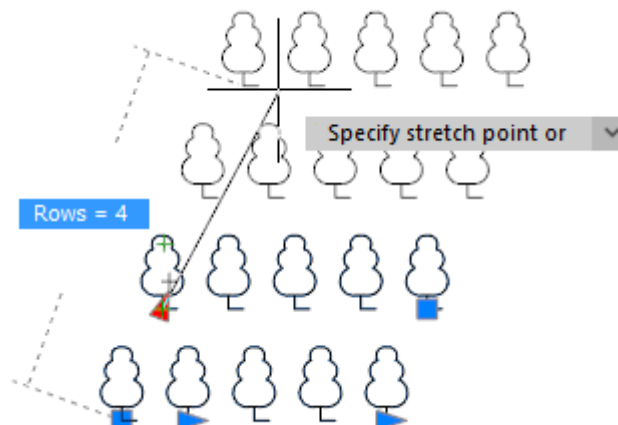

Undo

Undoes the last action

You can edit a rectangular associative array using grips. When you move the cursor over a grip, a menu with parameters available for changing is displayed.



## Polar Array

-  Ribbon: **Home - Modify** >  **Polar array**
-  Ribbon: **Draw - Modify** >  **Polar array**
-  Menu: **Modify** -  **Polar array**
-  Command line: **ARRAYPOLAR**

Even distribution of objects' copies in a circular array around a center point or rotation axis.

### Creating an array:

1. Run the command.
2. 2. Select objects to create an array, press **ENTER**.
3. Specify the array's central point – the point around which the array elements are distributed. The rotation axis is the Z axis of the current UCS.  
From this moment, the screen displays a preview of the array based on the current values of its parameters.
4. Configure the array parameters in the **Properties** bar, in the command line, context menu or using dynamic input.

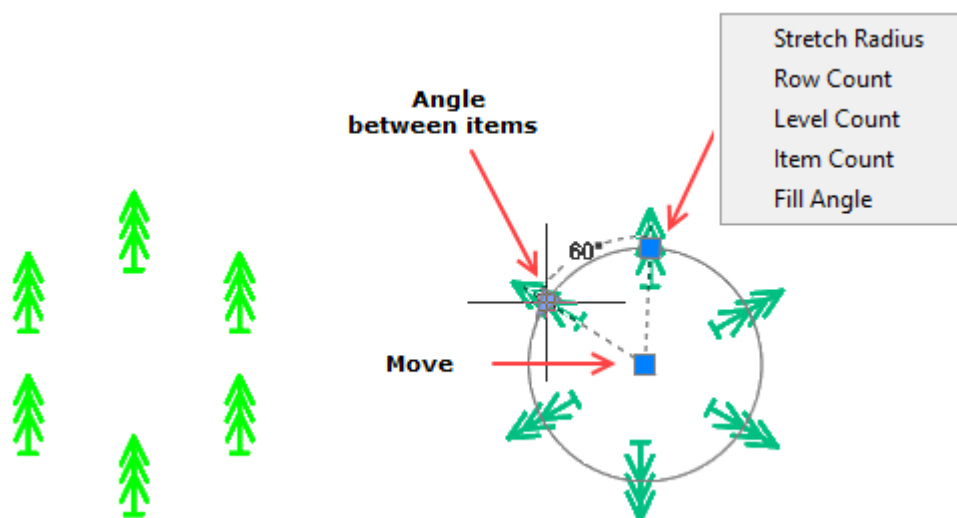

### Command prompts:

Select objects or [?]:

Selecting objects to be used in an array. The prompt appears if the objects were not preselected before the command starts.

Press **ENTER** upon the selection is completed.

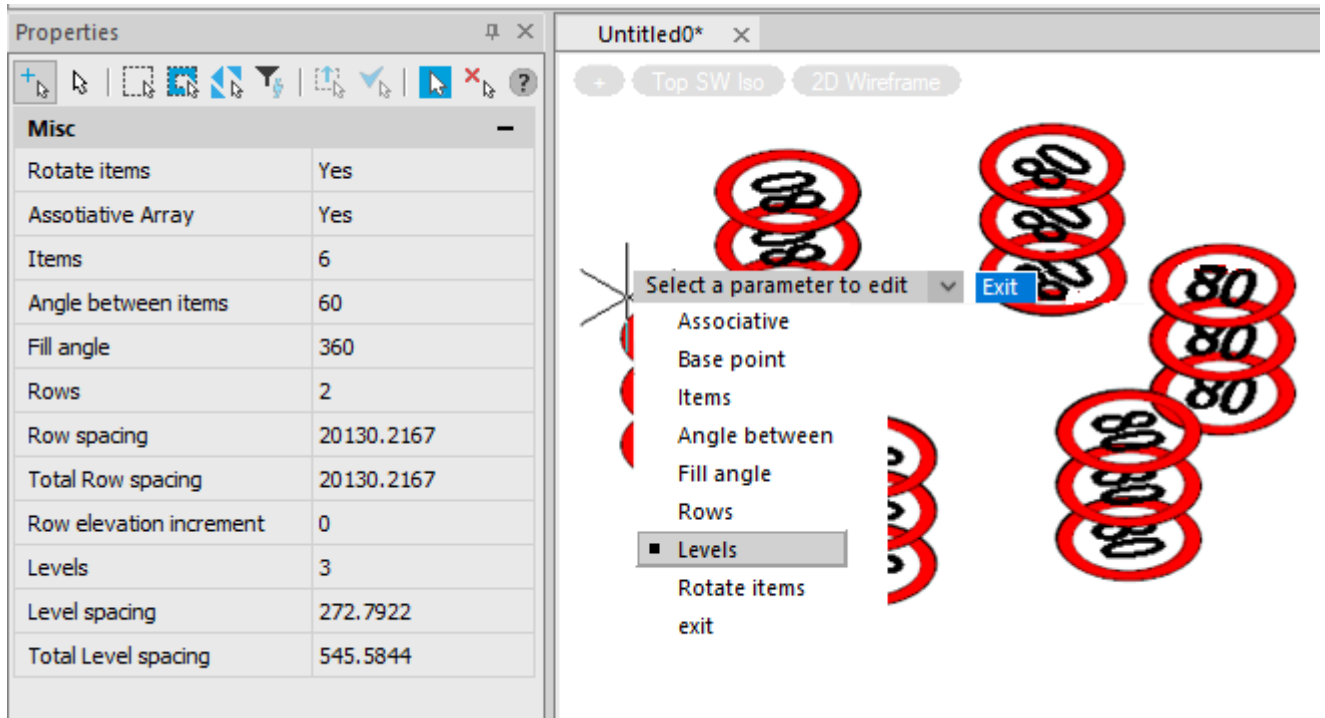

The command options can be edited in the **Properties** bar, in the dynamic input menu or in the command line.

**NOTE:** When specifying values in the dynamic input menu or command line, you should return to the **Properties** bar to display the actual values on it.

**Parameters:**

- Rotate items**      Whether to rotate the elements when creating the array relative to the array's center point.
- Associative**      Whether the array objects are associative or independent.
- Base point**      The location of the array's base point.
- Items**              The number of items in the array.
- Angle between**    Specifies the angle between adjacent elements.
- Fill angle**        The angle between the first and last items in the array.
- Rows**              Specifies the number of rows in the array.
- Row spacing**      Distance between rows.
- Total Row spacing** Specifies the total distance between the start and end row measured from their respective locations on the start and end item.
- Row elevation increment** The value by which the distance between each successive row of items increases or decreases. You can enter numerical values or measure distances on the screen.
- Levels**            The number of levels (for creating a 3D array).
- Level spacing**    Distance between levels - the difference in Z coordinate values between the levels of objects.
- Total Level spacing** The Z axis distance between the start and end level measured between equivalent points on the first and last level items.

The array can be edited using grips. When you move the cursor over a grip, a menu with parameters available for changing is displayed.

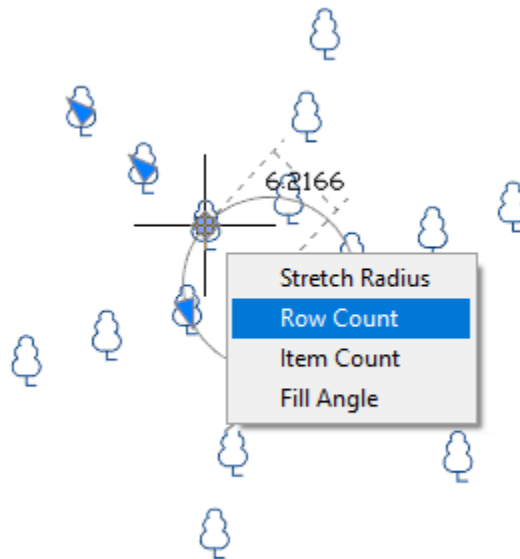

### Path Array



Ribbon: **Home - Modify** >  **Path Array**



Ribbon: **Draw - Modify** >  **Path Array**



Menu: **Modify** -  **Path Array**



Command line: **ARRAYPATH**

Even distribution of objects' copies in a circular array around a center point or rotation axis.

### Creating an array:

1. Run the command.
2.  Select objects to create an array, press **ENTER**.
3. Specify the path along which the objects should be placed.  
From this moment, the screen displays a preview of the array based on the current values of its parameters.
4. Configure the array parameters in the **Properties** bar, in the command line, context menu or using dynamic input.

### Command prompts:

Select objects or [?]:

Selecting objects to be used in an array. The prompt appears if the objects were not preselected before the command starts.

Press **ENTER** upon the selection is completed.



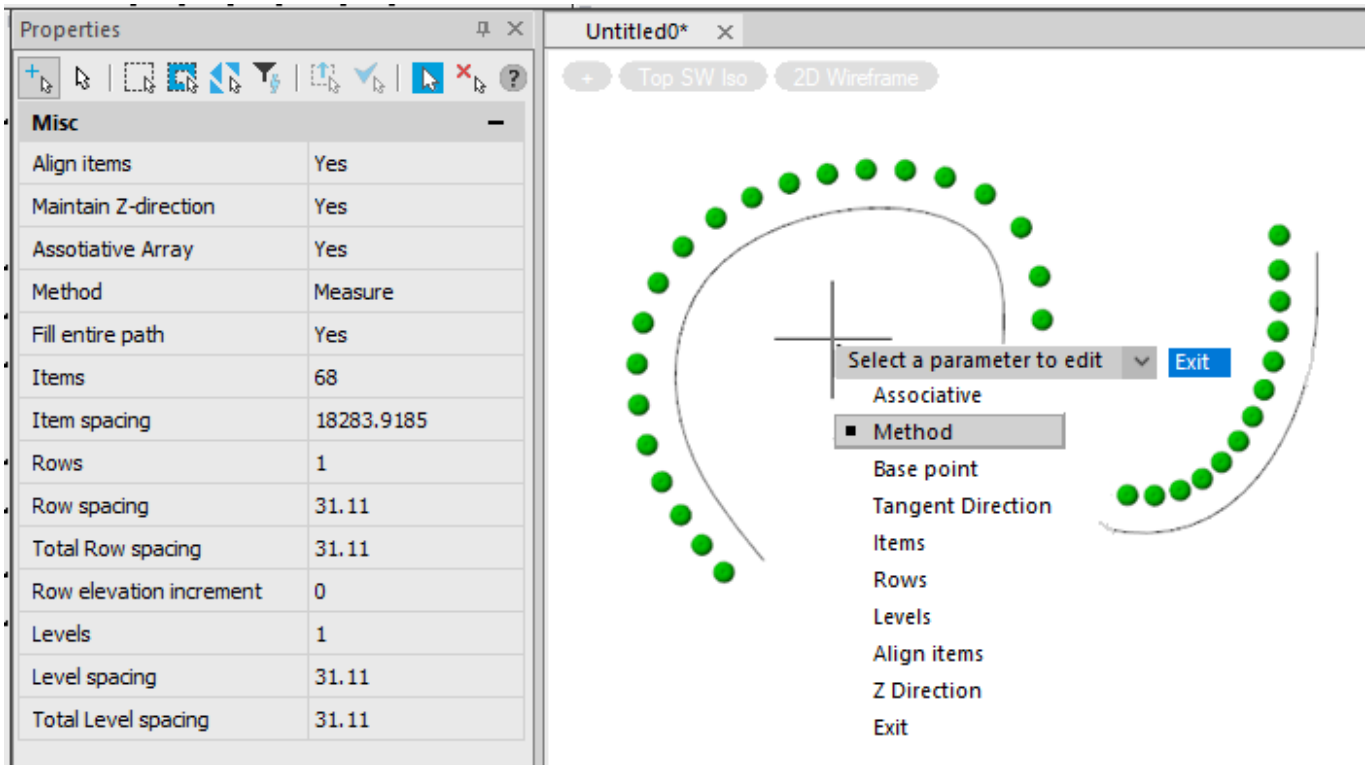

The command options can be edited in the **Properties** bar, in the dynamic input menu or in the command line.

**NOTE:** When specifying values in the dynamic input menu or command line, you should return to the **Properties** bar to display the actual values on it.

**Parameters:**

- Base point**                      Determines the base point of the array. Items in the path array are positioned relative to the base point.
- Tangent Direction**                      Determines how the array items are aligned relative to the starting direction of the path.  
Specifies two points that represent tangency of the array items with respect to the path. The vector of two points determines the tangency of the first element in the array. The **Align items** option controls whether other elements in the array are tangent or parallel.
- Align items**                      Whether to align each item tangentially to the path. Alignment is performed relative to the orientation of the first element.
- Z direction**                      Whether to maintain the original Z direction of the items or place them naturally along the 3D path.
- Associative**                      Whether the array items are associative or independent.
- Method**                      Controls the way the items are distributed along the path:  
**Divide** – even distribution of the specified number of elements along the entire path length.  
**Measure** – the distribution of items along the path at specified intervals.

<b>Fill entire path</b>	Adjusts the number of items when changing the path length: whether to strive to fill the entire path of the array with items to the end. The parameter is used, if <b>Measure</b> is selected as the <b>Method</b> for items distribution.
<b>Items</b>	The number of items along the path. The parameter is used, if <b>Divide</b> is selected as the <b>Method</b> for items distribution.
<b>Item spacing</b>	Specifies the spacing between adjacent items. The parameter is used, if <b>Measure</b> is selected as the <b>Method</b> for items distribution. By default, the array is filled with the maximum number of items that are placed along the path at the specified distance. Fewer items can be specified if desired. You can also enable the <b>Fill entire path</b> option to adjust the number of items as the path length change.
<b>Rows</b>	Specifies the number of rows in the array.
<b>Row spacing</b>	Distance between rows.
<b>Total Row spacing</b>	Specifies the total distance between the start and end rows measured from their respective locations on the start and end object.
<b>Row elevation increment</b>	The value by which the distance between each successive row of items increases or decreases. You can enter numerical values or measure distances on the screen.
<b>Levels</b>	The number of levels (for creating a 3D array).
<b>Level spacing</b>	Distance between levels - the difference in Z coordinate values between the levels of objects.
<b>Total Level spacing</b>	The Z-distance between the start and end levels measured between equivalent points on the first and last level items.



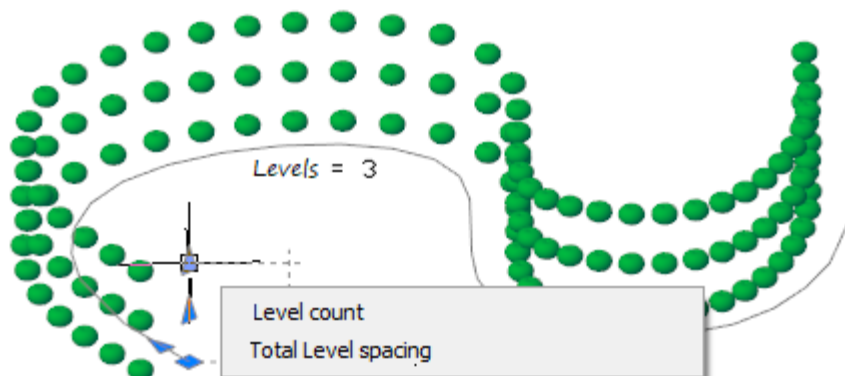



The array can be edited using grips. When you move the cursor over a grip, a menu with parameters available for changing is displayed.



### Editing an Array



Ribbon: **Home – Modify >**  **Edit Array**

-  Ribbon: **Draw - Modify >**  **Edit array**
-  Menu: **Modify -**  **Edit array**
-  Double click on an associative array
-  Command line: **ARRAYEDIT**

Command for editing associative array objects and their source objects.

**Command prompts:**

Select array or [?]:

Selecting an array for editing. The type of selected array (rectangular, circular, or path) determines subsequent prompts.

Press ENTER **ENTER** at the end of selection.

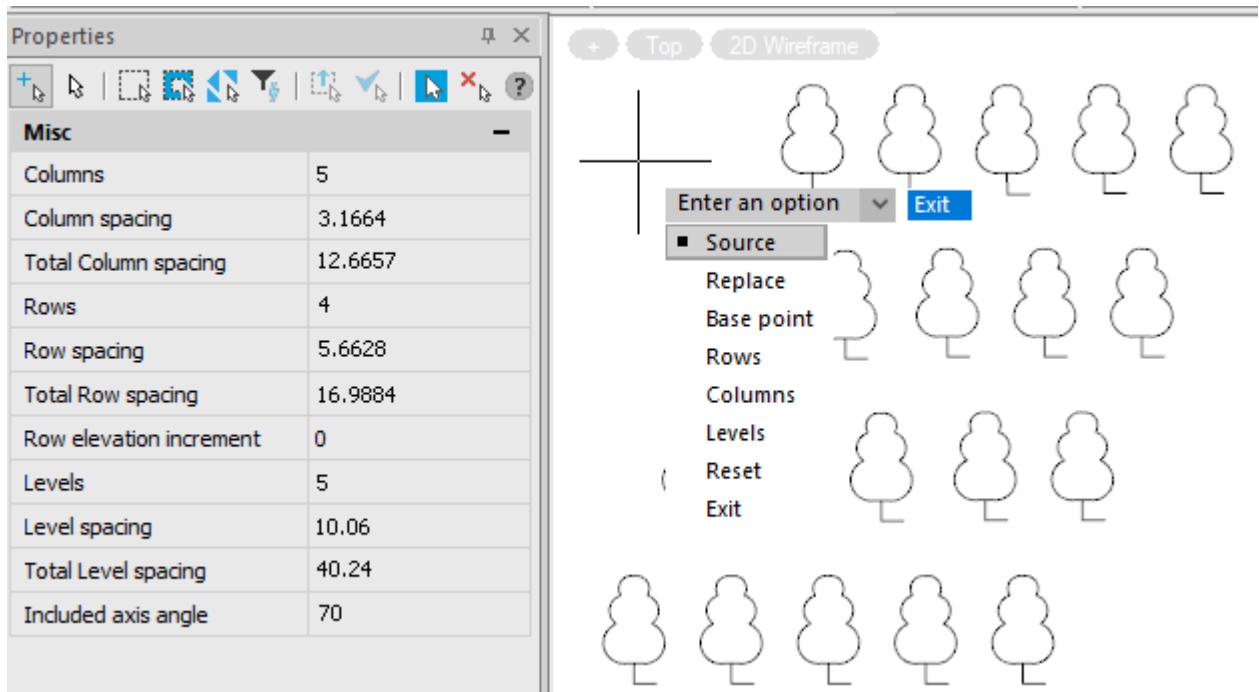

**Options:**

**Source**

Activates the mode to edit the array objects by the **Edit Reference** (REFEDIT) command, in which you can update the associative array by editing, adding and removing original elements.

In this mode, the Reference Editor tab is added to the ribbon, which allows you to edit, add or remove any existing or newly created object to the array, with the subsequent saving of the result.

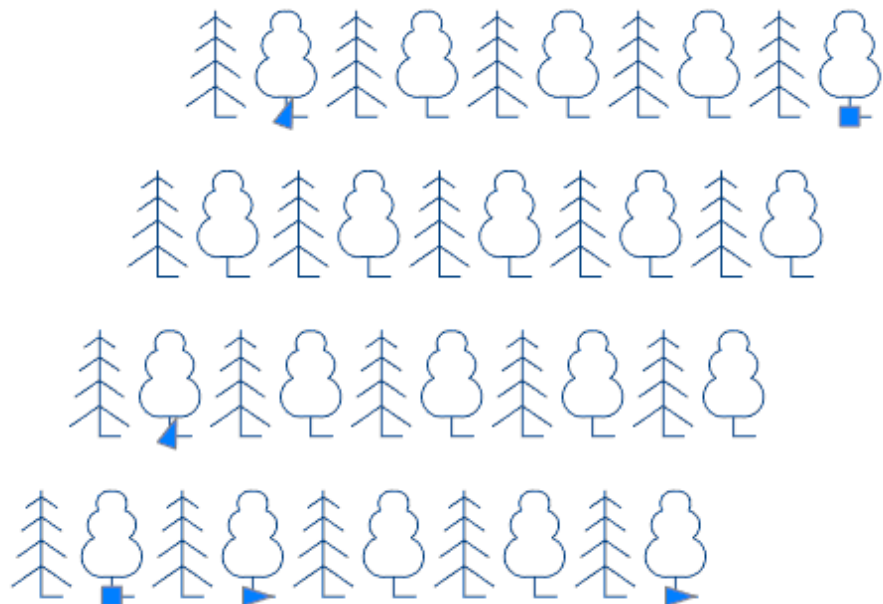
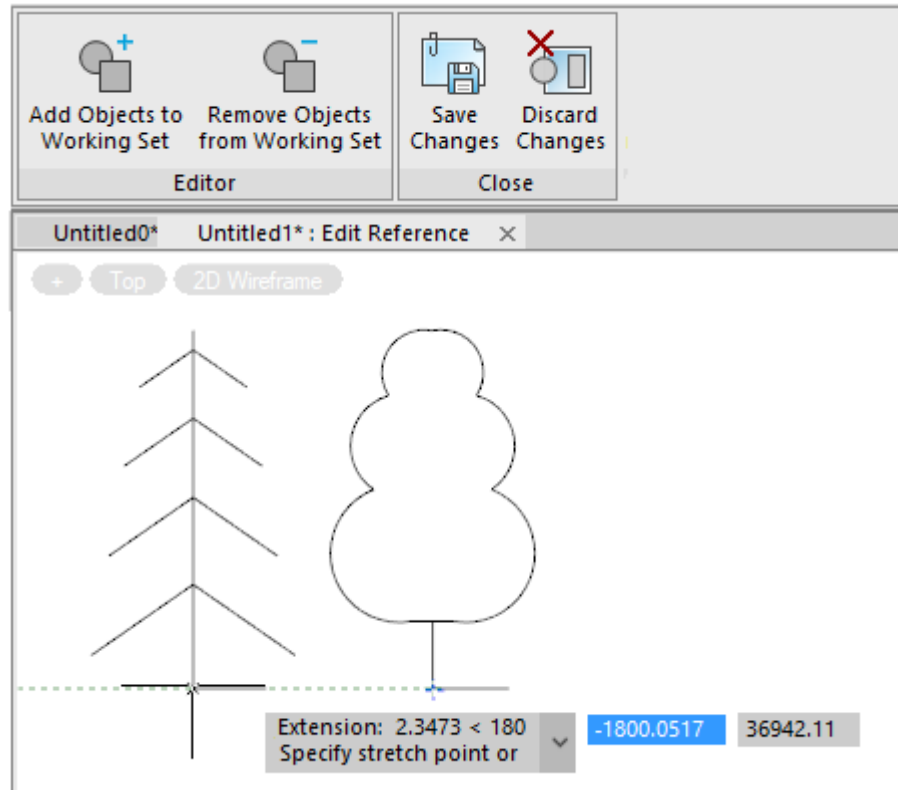

## Replace

Replaces the source objects for the selected items or for all items that refer to the source objects.

Select replacement objects or [?]:

Selection of new source objects.

Select base point of replacement objects [Key point]

<centroid>:

Specifies a base point for the placement of each replacement object.

Key point - Specifies the constraint point used for positioning.

Select an item in the array to replace or [Source objects]:

Specifies an array item for replacement and prompts to enter additional elements.

Source objects - Replaces the original set of source items in the array.

At the same time, all items that have not been replaced before are updated.

The rest of the parameters are determined by the type of the edited associative array and are described above in the commands for creating these arrays.

## 2D Arrays



Command line: **AR, ARRAYCLASSIC**

**Array** command opens the **Array** dialog box.



There is the **Select objects** command in the top corner of the dialog box; it temporarily closes the dialog box whilst selecting the source objects. There is a line showing the number of selected objects - **Objects selected** below the button.

There is a preview window below the line.

## Rectangular 2D Array

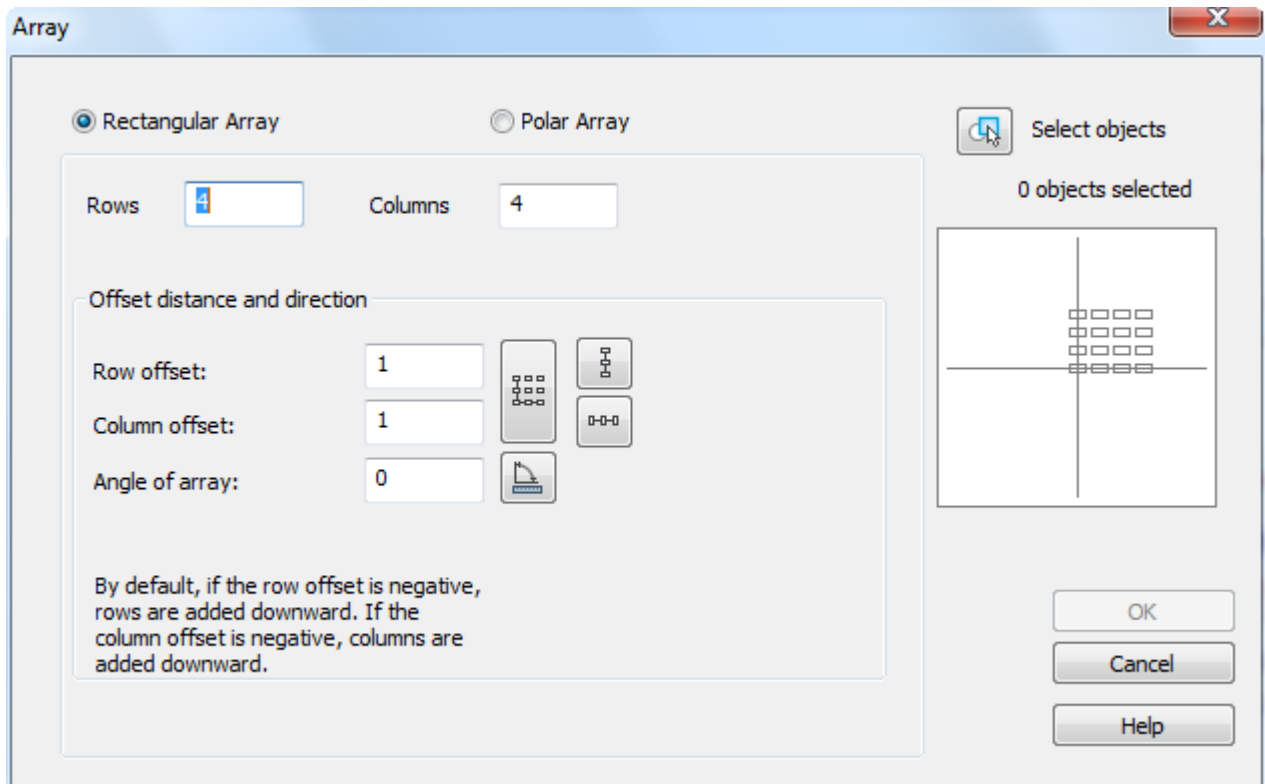

### Parameters:

**Rectangular array** Switches on the rectangular array mode.

**Rows:** Number of rows.

**Columns:** Number of columns.

### Offset distance and direction

**Row offset:** Distance between rows.

**Column offset:** Distance between columns.

**Angle of array:** Field to enter an angle of array.

**Buttons:** Button temporarily closes the dialog box to specify the distance or an angle on the screen.



Specify the distance between rows on the screen.



Specify the distance between columns on the screen.



Specify the distance between rows and columns on the screen.



Specify an angle of array on the screen.

### Example of creating stairs using rectangular array:

1. Create one more stair;
2. Select created objects;
3. Specify number of rows - 1;
4. Specify number of columns - 7;
5. Specify distance between columns (specify point 1, after that point 2);
6. Specify angle (specify point 1, after that point 2);

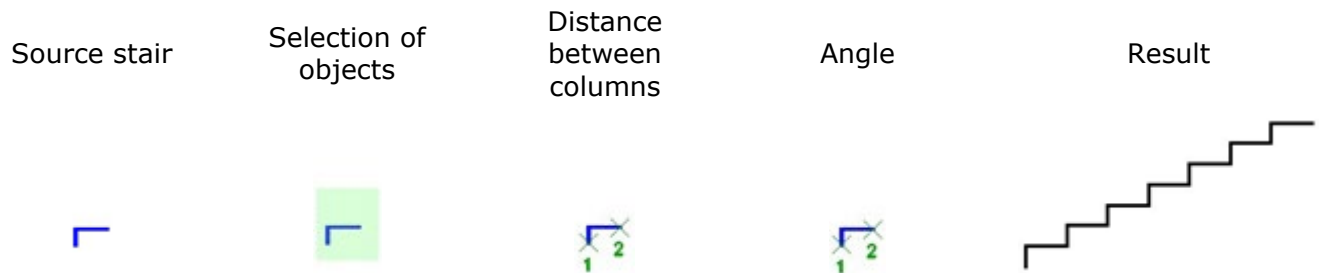

## Polar 2D Array

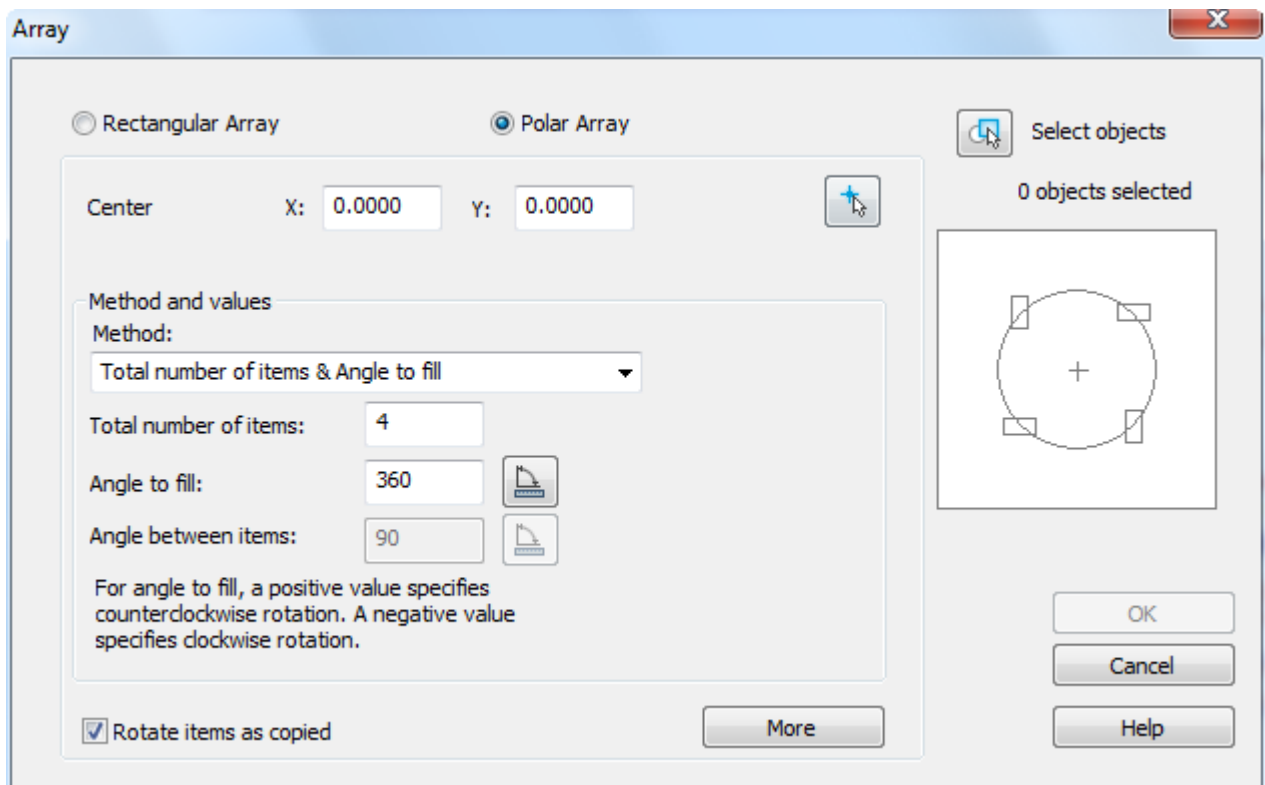

The **More** button opens an additional section of the dialog box to specify the base point of the X,Y axes.

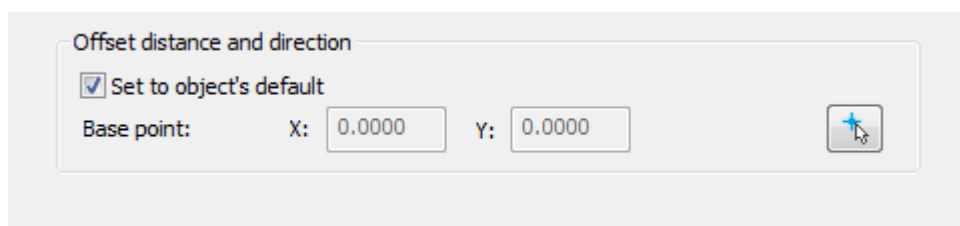

### Parameters:

**Polar array** Switches on the polar array mode.

**Center point: X: Y:**

Fields to enter the X, Y coordinates of the array center.



Button temporarily closes the dialog box to specify the center of the array on the screen.

*Method and values*

**Method:**

A drop-down list to select the method of array creation.  
Available options in the drop-down list:

- **Total number of items & Angle to fill**
- **Total number of items & Angle between items**
- **Angle to fill & Angle between items**

**Total number of items:**

Number of elements (with source object).

**Angle to fill:**

Angle of array fill.



Button temporarily closes the dialog box to specify the fill angle on the screen.

**Angle between items:**

Angle between neighboring array items.



Button temporarily closes the dialog box to specify the angle between neighboring array items.

**Rotate items as copied**

Switches on/off the mode for rotating the elements in the array.

**More/Less**

This button opens/closes an additional part of the dialog box.

*Offset distance and direction*

**Set to object's default**

Switches on/off the mode for specifying the base point.

**Base point: X: Y:**

Fields to enter the X,Y coordinates of the base point.



Button temporarily closes the dialog box to specify the base point on the screen.



### Example of creating polar array:

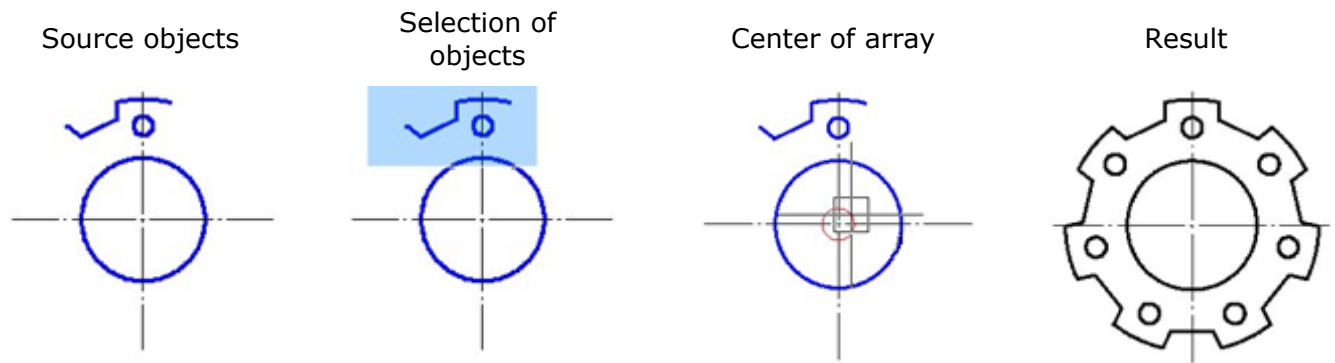

### ARRAY Command (non-dialog option)



Command line: - **AR**, -**ARRAY**

Creates non-associative 2D arrays using the command line.

#### Command options:

Select objects  
or [?]:

Selects objects to be used in the array. The request appears if the objects were not pre-selected before starting the command.

Press **ENTER** when you have completed your selection.

?

Calls additional options for selecting objects.

Rectangular

Creates an array of selected objects by orderly placing their copies at the nodes of a specified rectangular grid.

Polar

Creates an array of selected objects by orderly placing copies of them around a central point.

#### Command options in rectangular array creation mode:

Enter the  
number of rows  
(---) <4>:

Enters the number of rows (integer from 1 to 32767).

Enter the  
number of  
columns (|||)  
<4>:

Enters the number of columns (an integer from 1 to 32767). If the number of rows is 1, the number of columns must be at least 2, and vice versa.

Enter distance  
between rows  
(---) <1>:

Specifies the distance between rows, including the object length. If you enter a negative number, copies of objects will be located below the original.

Instead of distances between rows and columns, you can enter the coordinates of points (2 values), then the distances will be determined by a rectangle constructed by two opposite points. After entering the coordinates of the first point in the command line, the **Second point** prompt will appear

Enter distance  
between  
columns (|||)  
<1>:

Specifies the distance between columns, including the object length. If you enter a negative number, copies of objects will be located to the left of the original.

#### Command options in circular array creation mode:

Enter array center  
or [Base]:

Specifies the coordinates of the central point – the point around which the array elements are distributed.

**Options:**

Enter the number of items in the array:

Specify the angle to fill (+= ccw, - = cw) [360]:

Angle between items:

Rotate arrayed objects [Yes/No] <Yes>:

**Base** – Resets the base point of the object - the point that remains at a constant distance from the center point when constructing the array.

Enters the number of elements in the array, including the source object (an integer from 2 to 32767). If no value is entered, an array will be created based on the fill angle and element angle values.

Specifies the angle between the base points of the first and last array items. A positive value specifies counterclockwise rotation, a negative value specifies clockwise rotation.

Specifies the angle between two adjacent array items if the number of elements in the array has not been specified.

Enables/disables the mode of rotating elements relative to the center point of the array.

## 3dArray 3D Arrays

 Ribbon: **Draw - Modify** >  **3D Array**

 Menu: **Modify** -  **3D Array**

 Command line: **3DARRAY**

Creates copies of selected objects arranged in a rectangular or polar array.

### Rectangular 3D Array

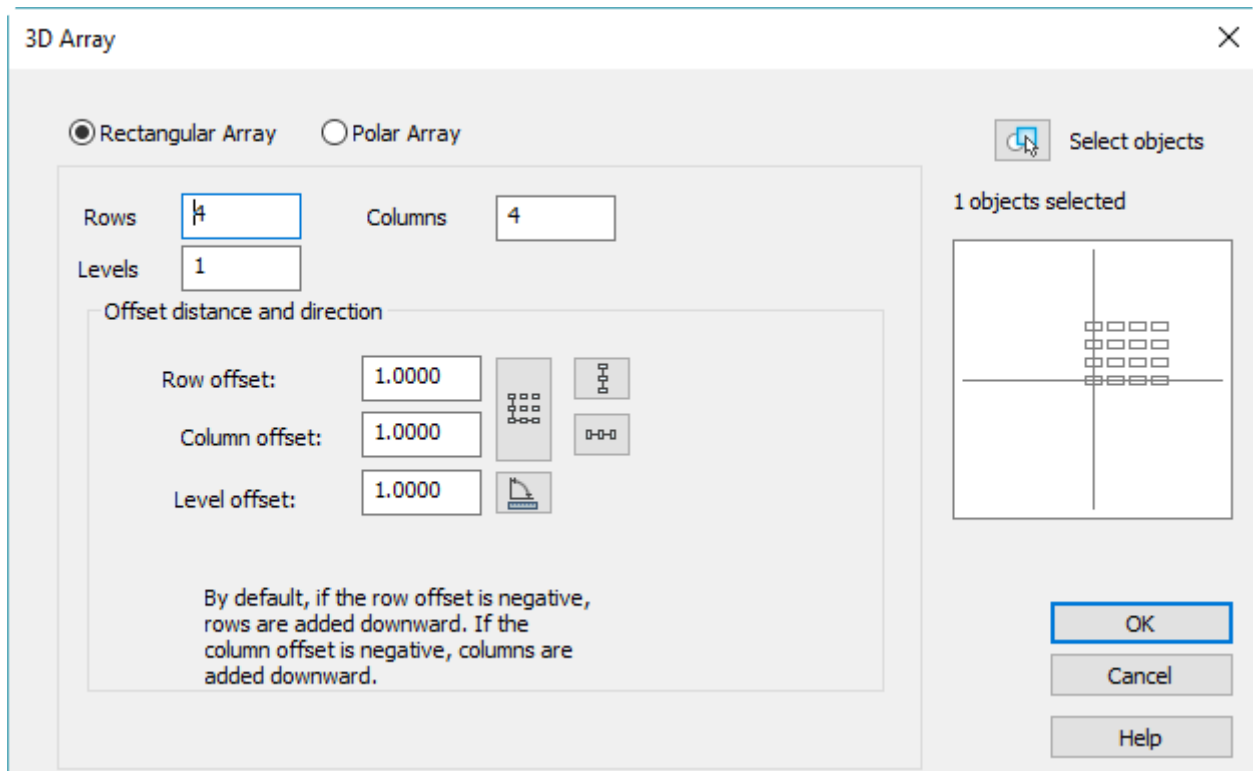

**Options:**

**Rectangular Array**

Selects the Rectangular Array mode.

- Rows:** Specifies the number of rows.
- Columns:** Specifies the number of columns.
- Levels:** Specifies the number of levels.

*Offset distance and directions*

- Row offset:** Specifies offset distance for rows.
- Column offset:** Specifies offset distance for columns.
- Level offset:** Specifies offset distance for levels.
- Measure buttons:** Measures distance on screen.



Specifies rows offset.



Specifies columns offset.



Specifies both offsets.



Specifies rotation angle.

**Polar 3D Array**

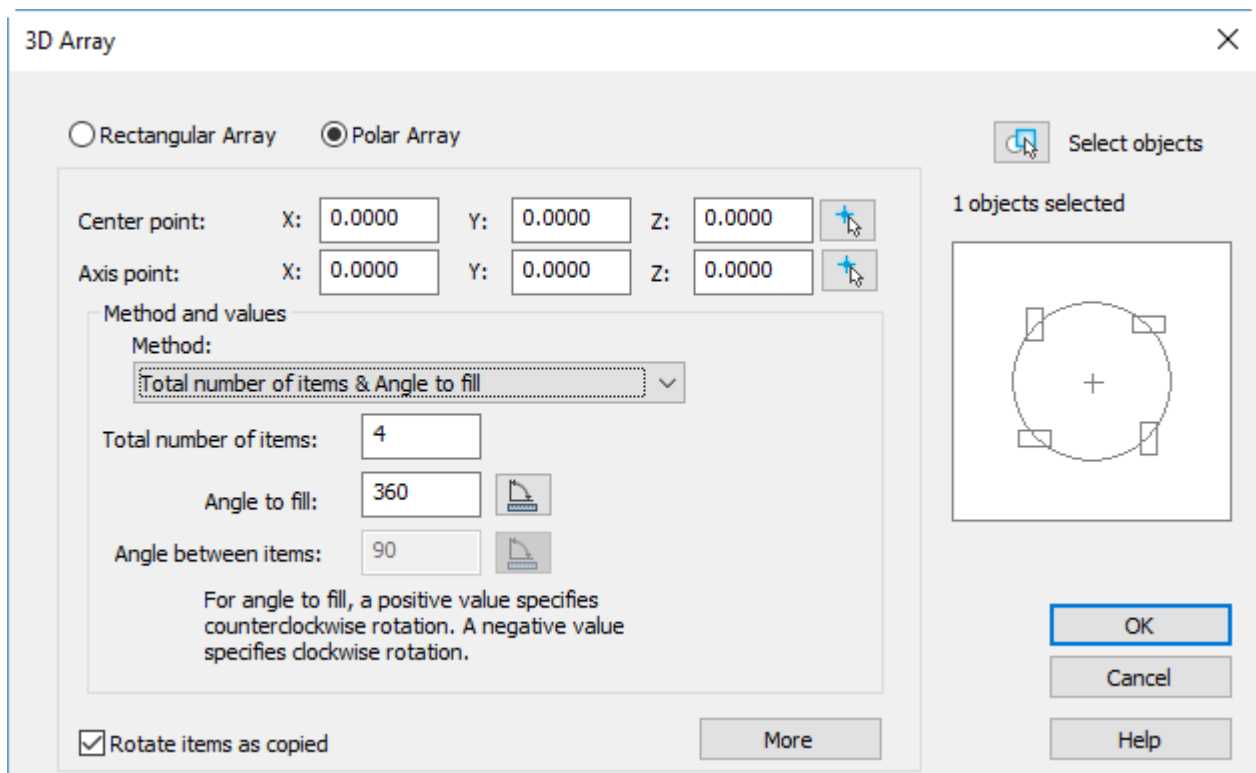

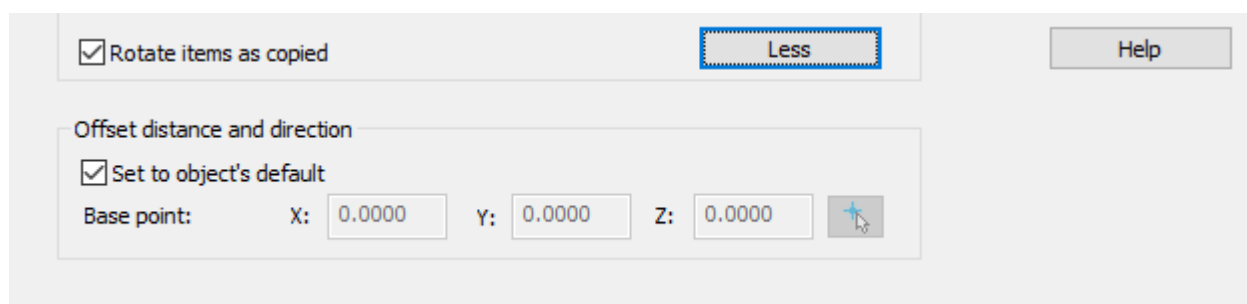

The **More** button shows additional options for Offset distance and direction:









### Options:

<b>Polar Array</b>	Selects the Polar Array mode.
<b>Center point : X: Y: Z</b>	Array center point X, Y and Z coordinates.
<b>Axis point: X: Y: Z</b>	Second axis point X, Y and Z coordinates.
	Selects point on screen.

### Method and values

<b>Method:</b>	Selects the method to create Polar array: <ul style="list-style-type: none"> <li>• <b>Total number of items and Angle to Fill</b></li> <li>• <b>Total number of items and Angle between items</b></li> <li>• <b>Angle to fill and Angle between items</b></li> </ul>
<b>Total number of items:</b>	Specifies the number of arrayed items, including the original.
<b>Angle to fill:</b>	Specifies the angle between the first and last item in the array. A negative number produces a clockwise array rotation.
	Specifies the angle on screen.
<b>Angle between items:</b>	Specifies the angle between items in the array.
	Specifies the angle on screen.
<b>Rotate items as copied</b>	Controls whether items are rotated as they are arrayed.
<b>More/Less</b>	Shows/hides additional options.

## Deleting Duplicate Objects

-  Ribbon: **Home - Modify >**  **Delete duplicates**
-  Menu: **Modify -**  **Delete duplicates**
-  Toolbar: **Modify Object -** 
-  Command line: **DELETEDUPLICATES, OVERKILL**

The command is intended for deleting repeating or overlapping objects: points of lines, arcs, circles and polylines.

In the process of the command work, the geometry of the selected objects is compared, duplicate elements are deleted.

1. Run the **Delete duplicates** command.
2. Select objects in the drawing.
3. Configure object comparison parameters in the dialog box that appears.

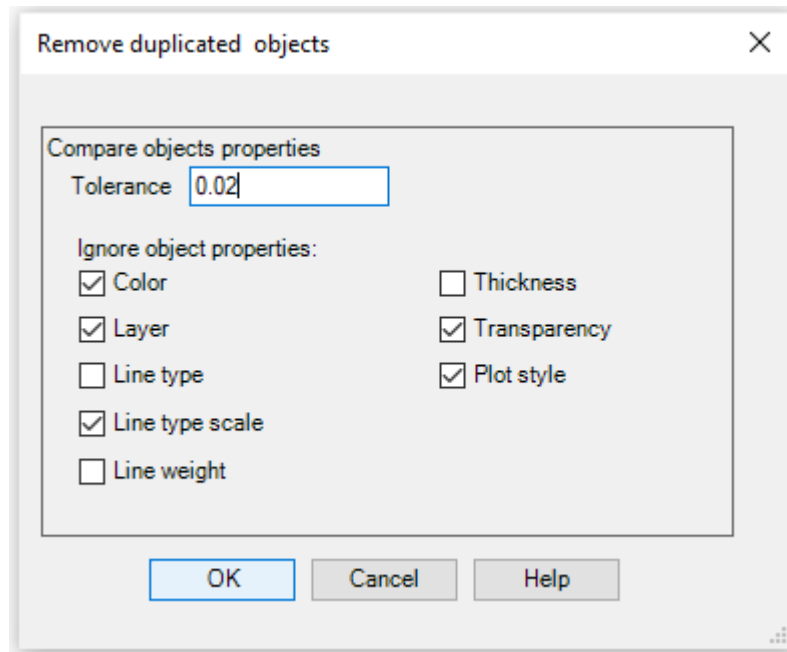

**Tolerance** Sets the precision with which numeric comparisons of object parameters is made. If this value is 0, the objects being compared must match completely for the command fulfillment.

**Ignore object property:** Selects object properties to ignore during comparison.

4. Click **OK**.
5. Select an action in the command line:

Delete duplicates? [All/Current/Skip] <All>:

**Command options:**

- All Delete all found duplicates.
- Current Delete the selected object.
- Skip Move to the next object without deleting the selected one.

## Move

 Ribbon: **Home, Draw - Modify >**  **Move**

 Menu: **Modify -**  **Move**

 Toolbar: **Modify -** 

 Hotkeys: **CTRL+D**

 Command line: **M, MOVE**

This command is used to move the selected objects to a specified distance and in a specified direction.

The **Displacement** option allows moving of objects by specifying a relative distance with coordinates. Coordinates define a value for the displacement of objects.

### Command options:

? Opens the additional options to select objects.

Displacement Specifies relative distance and direction using coordinates.

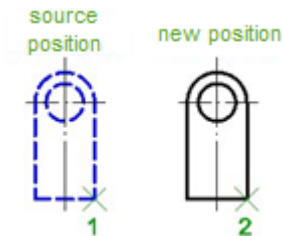

### Command prompts:

Select objects or [?]:

Select objects. Press **ENTER** when the selection is finished.

Specify base point or [Displacement]:

Specify a 1 base point.

Specify second point or <use first point as displacement>:

Specify a 2 second point.

## Rotate



Ribbon: **Home, Draw – Modify >**  **Rotate**



Menu: **Modify –**  **Rotate**



Toolbar: **Modify –** 



Hotkeys: **CTRL+E**



Command line: **RO, ROTATE**

The command rotates the selected objects to a specified angle around the specified point.

### Command options:

? Opens the additional options to select objects.

Copy Rotates a copy of the selected object.

Reference angle Specifies the angle from the reference angle.



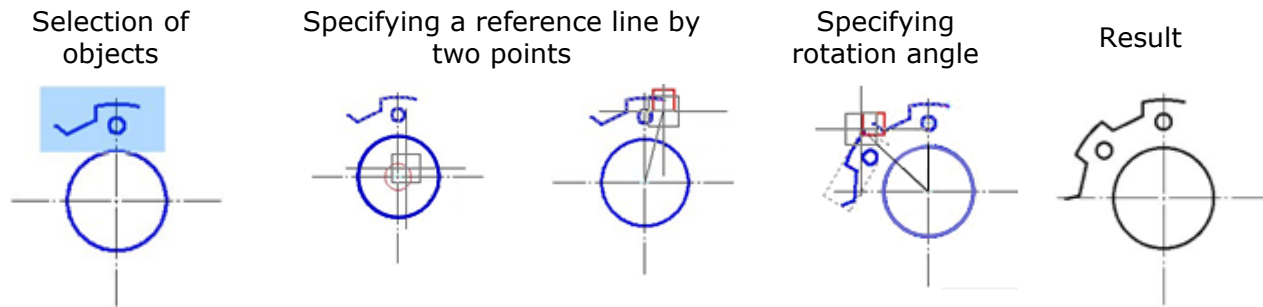



Points Specifies the angle from the reference angle to the line specified by two points.



### Command prompts:

Select objects or [?]:	Select objects. Press <b>ENTER</b> when the selection is finished.
Specify base point:	Specify a base point.
Specify rotation angle or [Copy/Reference angle]:	Select the <u>C</u> opy option.
Specify rotation angle or [Copy/Reference angle]:	Select the <u>R</u> eference angle option.
Specify the reference angle:	Specify a first point of reference.
Specify second point:	Specify a second point of reference.
Specify the new angle or [Points]:	Specify the angle.

## Scale

-  Ribbon: **Home, Draw - Modify >**  **Scale**
-  Menu: **Modify -**  **Scale**
-  Toolbar: **Modify -** 
-  Command line: **SC, SCALE**

This command is used to decrease or increase the size of the selected objects whilst retaining their proportions (the scale factors along the X and Y axes are identical). If the scale factor is more than 1, the objects are increased in size; if it is less than 1, they are decreased. The specified scale factor value is retained in the current work session until it is changed again. The command is applicable to lines, polylines, circles, arcs, splines, and ellipses.

### Command options:

<u>?</u>	Opens the additional options to select objects.
<u>C</u> opy	Scaling copy of the selected objects.
<u>R</u> eference <u>l</u> ength	Scaling the selected objects towards the reference line whose length is a single scale factor and a new length for the reference line.

Points                    Scaling the selected objects towards the reference line whose length is a single scale factor and a new length for the reference line, specified by two points.

Non-uniform scale                    Setting different scales along the X-axis and Y-axis. When scaling circles and arcs non-uniformly, they are replaced by ellipses.

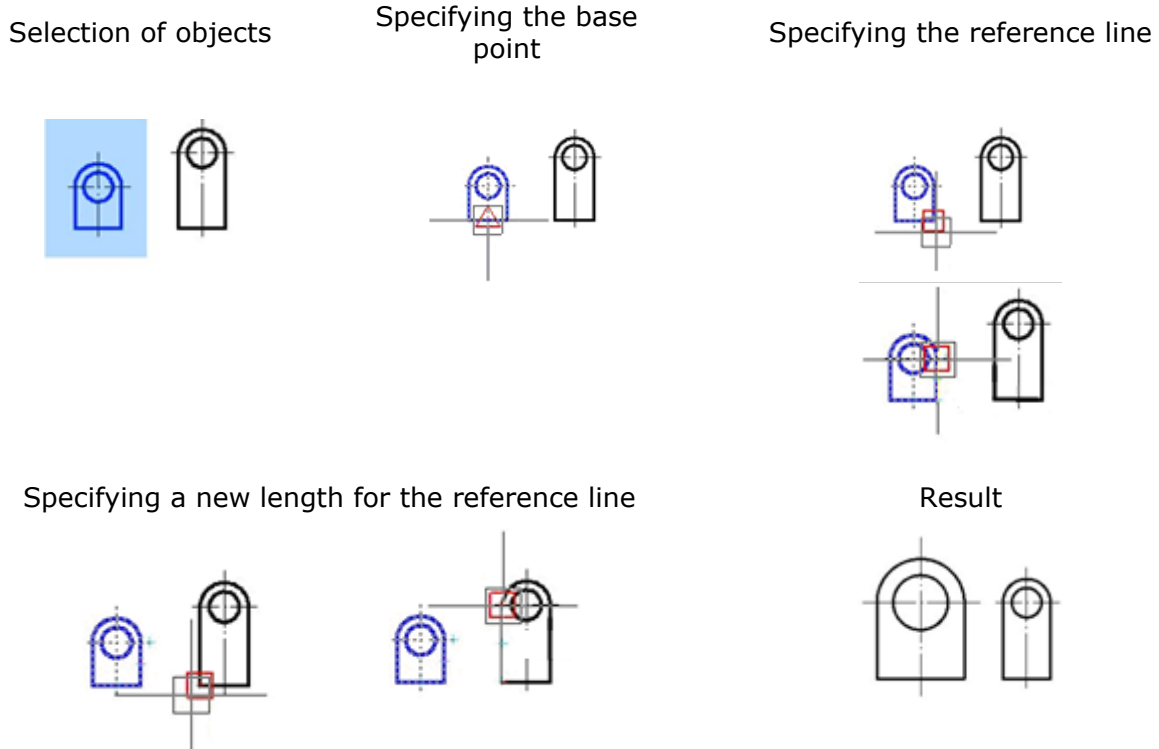

**Command prompts:**



- |  |  |
|--|--|
| Select objects or [?]:                           | Select objects. Press <b>ENTER</b> when the selection is finished. |
| Specify base point:                              | Specify the base point.  |
| Specify scale factor or [Copy/Reference length]: | Select the <u>Reference length</u> option.                         |
| Specify reference length:                        | Specify the first point.   |
| Specify second point:                            | Specify the second point.  |
| Specify the new length or [Points]:              | Select the <u>Points</u> option.                                   |
| Specify first point:                             | Specify the first point.   |
| Specify second point:                            | Specify the second point.  |



## Stretch

 Ribbon: **Home, Draw – Modify >**  **Stretch**

 Menu: **Modify –**  **Stretch**

 Toolbar: **Modify –** 

 Command line: **S, STRETCH**

This command allows stretching or moving of objects. Objects, intersecting with a secant frame or polygon are stretched. Objects inside a frame or polygon are moved by the **Stretch** commands as they are moved by the **Move** command.

Lines, arcs and segments are stretched only by moving their end points inside the secant frame or polygon. The position of endpoints outside the secant frame or polygon remain the same.

Other primitives are moved or not, according to whether or not their characteristic points are inside the secant frame (polygon).

Characteristic points are the center of a circle, the insertion point of a block, the leftmost point of a base line for text and to define attributes (it does not depend on the aligning type used for creation).

If the insertion point of a block is moved by the **Stretch** command, all its attributes are also moved.

During the preliminary selection of objects, only objects selected with the ordinary or secant frame (polygon) are stretched with **Stretch** command.

The Displacement option allows stretching or moving of objects by specifying a relative distance with coordinates. Coordinates define a value for the stretching or offset of objects.

### Command options:

? Opens the additional options to select objects.

Displacement Specifies the relative distance and direction using coordinates.

Selection of objects by secant frame

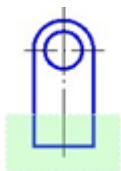

Specifying base point

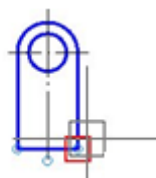

Specifying a new point

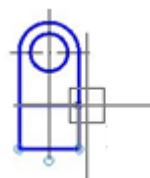

Result



### Command prompts:

Select objects or [?]:

Select objects. Press **ENTER** when the selection is finished.

Specify base point or [Displacement] <Displacement>:

Specify the base point.

Specify second point or <use first point as displacement>:

Specify the second point.

## Align

 Ribbon: **Draw - Modify >**  **Align**

 Menu: **Modify –**  **Align**

 Command line: **ALIGN**

This command moves and rotates an object to align it with another object; scaling is also possible.

The action performed by the command is determined by the number of pairs (source – destination) of the specified points.

When you *specify one pair of points*, you can move objects to the distance specified by the points.

### Command prompts to move objects:

Select objects or [?]:

Select objects to align.

Press **ENTER** when selection is completed.

Specify first source point:

Specify the first point on the object to be aligned.

Specify first destination point:

Specify the first point on the destination object.

Press **ENTER** to complete the action.

When you *specify two pairs of points*, the selected objects can be moved, rotated and scaled on a plane or in space.

The first pair of points sets the base point for the alignment

The second pair of points sets the rotation angle of the aligned object

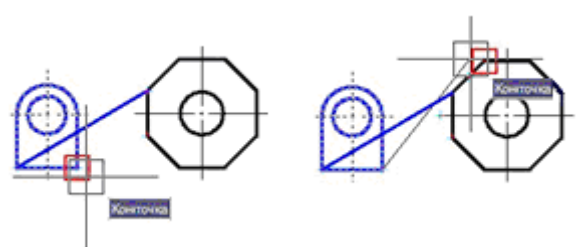
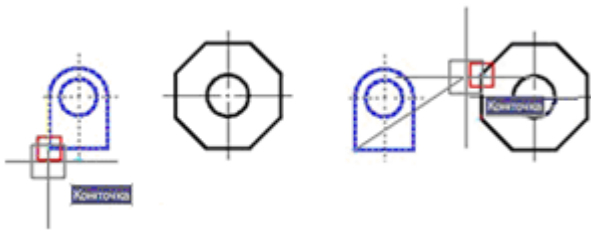

### Command prompts to move and rotate objects:

Select objects or [?]:

Select objects to align.

Press **ENTER** when selection is completed.

Specify first source point:

Specify the first point on the object to be aligned.

Specify first destination point:

Specify the first point on the destination object.

Specify second source point:

Specify the second point on the object to be aligned.

Specify second destination point:

Specify the second point on the destination object.

Specify third source point or:

Press **ENTER**. Select the option whether

to scale the object to be aligned.

*Scaling* is only possible when aligning with *two pairs* of points.

Scale objects based on alignment points? [Yes/No] <N>:

Select the desired option.

### Command options:

Yes Scales an object based on alignment points.  
The distance between the first and second destination points is taken as the reference length for scaling.

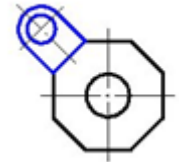

No Does not scale an object based on alignment points.  
The object to be aligned is rotated relative to the destination object without scaling.

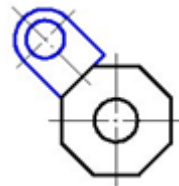

When you specify three pairs of points, objects can be moved and rotated in 3D space.

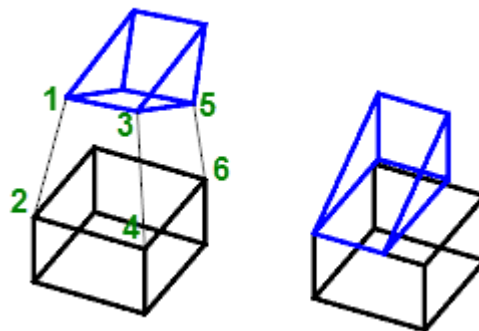

After specifying the first (1-2) and the second (3-4) pair of points, continue actions:

Specify third source point:

Specify the third point on the object to be aligned (5).

Specify third destination point

Specify the third point on the destination object (6).

**ATTENTION!** Scaling is not performed with this action and is only available when using two pairs of points.

## Distributing Copies



The **Divide** and **Measure** commands distribute points and blocks at the *same* or *specified distance* from each other along an object's perimeter or length. Objects are not actually divided into parts. The locations of the divisions are specified. Points located in the places of divisions can be used as geometric characteristic points for further creations.

### Divide



Ribbon: **Home, Draw - Draw** >  **Divide**

 Menu: **Draw – Point >  Divide**

 Toolbar: **Draw– **

 Command line: **DIVIDE**

The **Divide** command distributes points or blocks at the same distance from each other along an object’s length or perimeter. Distribution along object points or blocks divides the object into segments of a specified length.

**Command options:**

? Opens the additional options to select objects.

Block Switches to block insertion mode.

Yes Switches on the object to block aligning mode.

No Switches off the object to block aligning mode.

Block and objects to divide

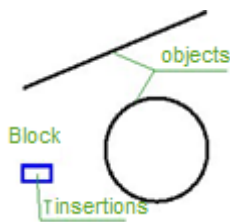

Dividing with block aligning

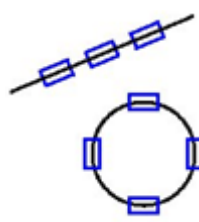

Dividing without block aligning

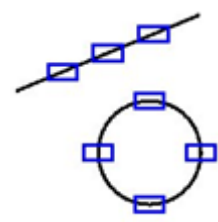

**Command prompts:**

Select objects to divide or [?]:

Select an object.

Enter number of segments or [Block]:

Select the Block option.

Enter name of block to insert:

Specify the block’s name and press **ENTER**.

Align block with object? or [Yes/No]:

Specify the option.

Enter number of segments:

Specify the number of segments and press **ENTER**.

**Measure**

 Ribbon: **Home, Draw - Draw >  Measure**

 Menu: **Draw – Point>  Measure**

 Toolbar: **Draw – **



Command line: **MEASURE**

The **Measure** command distributes points or blocks at the specified distance from each other along an object's length or perimeter. Distribution along object points or blocks divides the object into segments of a specified length. The last segment of the object is always smaller than others.

**Command options:**

- ? Opens the additional options to select objects.
- Block Switches to block insertion mode.
- Yes Switches on the object to block aligning mode.
- No Switches off the object to block aligning mode.

Block and objects to measure

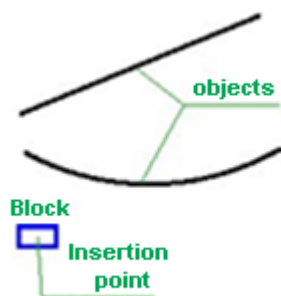

Measuring with block

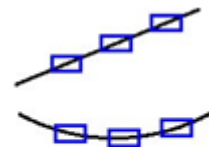

**Command prompts:**

Select objects or [?]:

Specify length of segment or [Block]:

Enter name of block to insert:

Specify length of segment:

Select the object.

Select the Block.

Enter a name of the block and press **ENTER**.

Specify a length or specify it on the screen.

## Chamfer



Ribbon: **Home, Draw - Modify** >  **Chamfer**



Menu: **Modify** -  **Chamfer...**



Toolbar: **Modify** - 



Command line: **CHA, CHAMFER, MCHAMFER**

This command is used to create chamfers at the points of intersection of objects, with automatic dimensioning ability. The command allows the creation of several chamfers individually.

The **Chamfer** command can be used for quick trimming or lengthening of selected objects. To do so, press the **SHIFT** button when you select objects: a current value of chamfer radius is temporarily changed to 0 and objects are lengthened or trimmed to intersection point.

After launching the command, the dialog box for specifying the chamfer parameters opens:

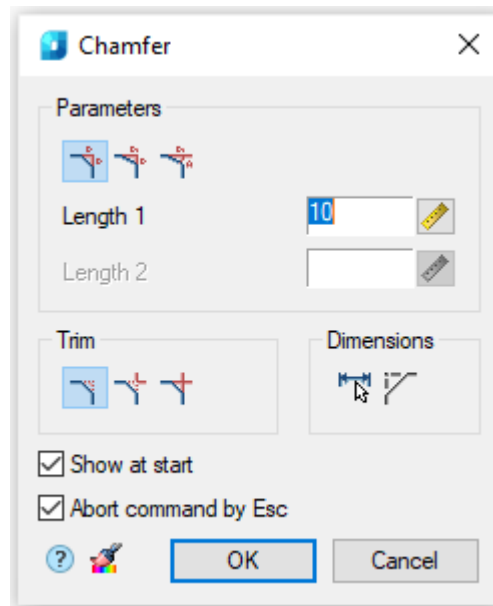

### Parameters:



This button switches on the mode for creating a chamfer with similar lengths.

In this mode the **Length 2** parameter is unavailable.

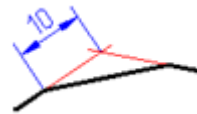

This button switches on the mode for creating a chamfer with different lengths.

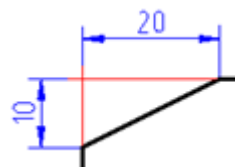

This button switches on the mode for creating a chamfer by length and angle.

In this mode there is a **Corner** parameter instead of the **Length 2** parameter.

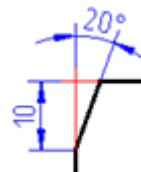

**Length 1** The first length of the chamfer. This field is used also to specify chamfers with similar lengths.

**Length 2** The second length of the chamfer.

**Angle** Angle of the chamfer.



This button temporarily closes the dialog box to permit measuring the chamfer length and angle on the drawing. The **Value picker** dialog box

appears to perform measurements.



This button switches on the mode for cutting of full contour lines.

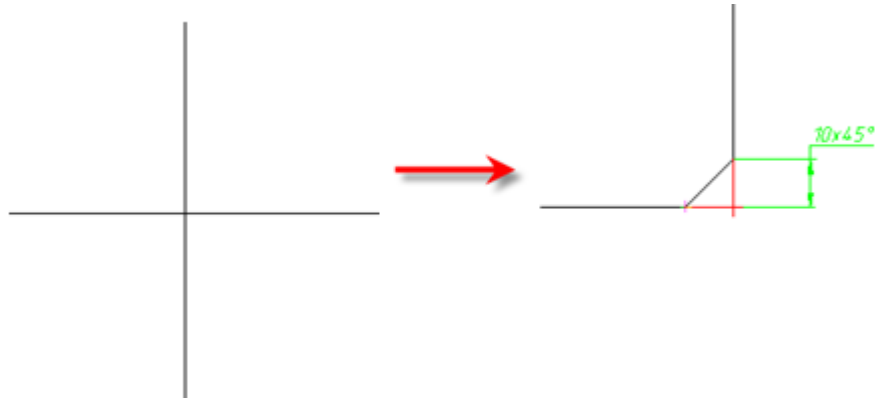

This button switches on the mode for cutting of partial contour lines before their intersection.

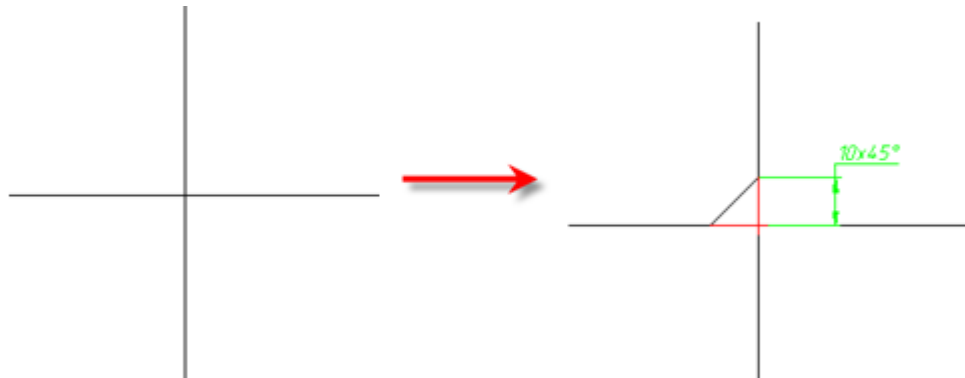

This button switches on the mode without lines cutting.



This button temporarily closes the dialog box to permit copying of properties from created chamfers.



This button switches the automatic dimensioning mode on/off.

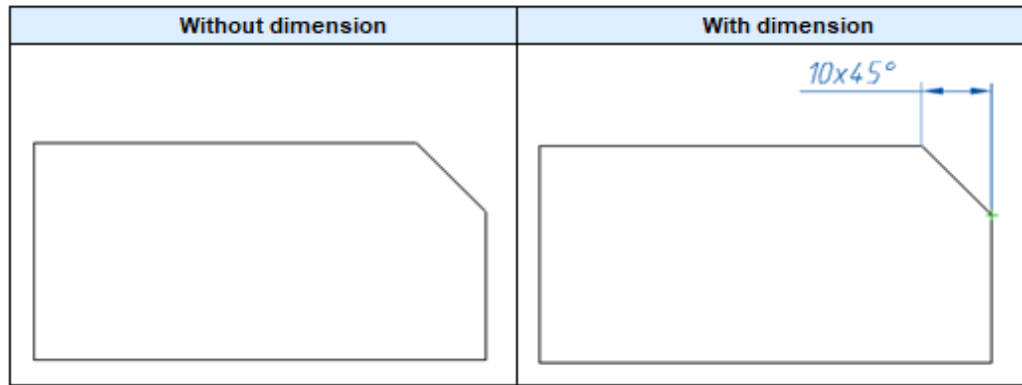

**Build auxiliary lines** – the switch that controls the display of an auxiliary line when dimensioning the chamfer.

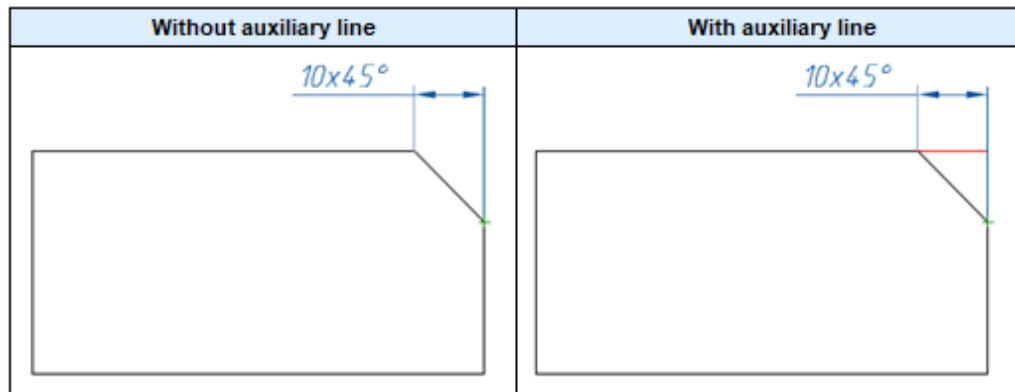

**Show at start**

When this check box is clear, **Chamfer** dialog box is not displayed, i.e. it allows you to reconfigure the command to work in a non-dialog mode. For a repeated call of the dialog, select the prOPERTIES option in the command line or in the context menu. Such mode of operation is convenient, when you have to frequently use the command without changing its parameters.

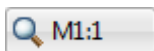

This drop list sets Object scale for dimension object.

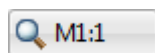

Field with a drop-down list that sets the drafting scale for a dimensional object created as a result of the command. This field is displayed only in case when the *Measurement scale* mode is selected in the program status bar.

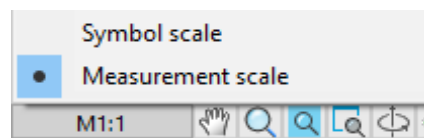

Double clicking or right clicking in the fields to enter values will open the context menu with a list of the recently entered values:

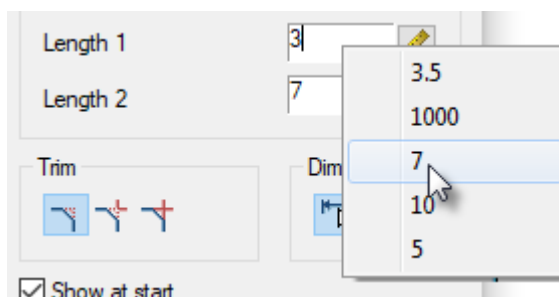



Options in the context menu and in the command line are available during the process of chamfer creation:

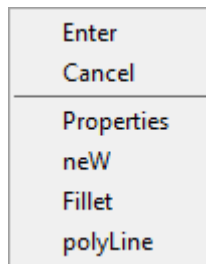

**Command options:**

**Properties** The **Chamfer** dialog box opens to change the chamfer parameters.

**neW** Finishes the creation of one group of chamfers and starts another. The command is applied when you need to create some chamfers with similar dimensions on one object and with the same dimensions on another object:

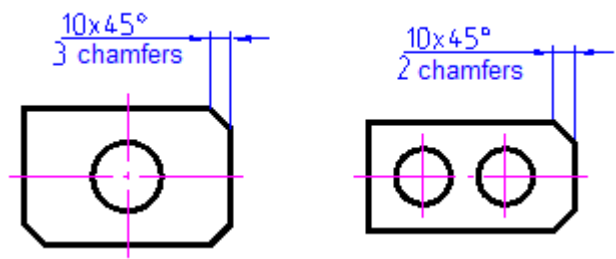

**Fillet** Switches to the mode for creating fillets. The **Fillet** dialog box opens to specify the parameters for the fillet.

**polyLine** Switches to the mode of making chamfers along a whole selected polyline.  
 Only segments with lengths which are more than chamfer length are processed.  
 It is recommended to specify the same values for both chamfer lengths.  
 This option is available for symmetrical chamfer.  
 Auto dimensions and cutting of countor modes are ignored.

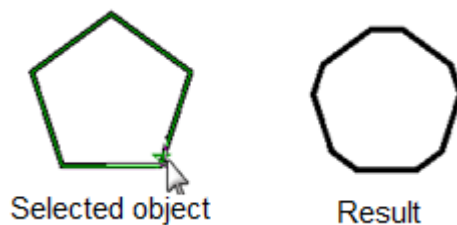

**Features of the command operation**

The command works in 3D. to perform the command, the original primitives should lie in the same plane.

If you press and hold the **SHIFT** key while selecting the second object, then a corner will be formed (snapping at the intersection point and cutting off).

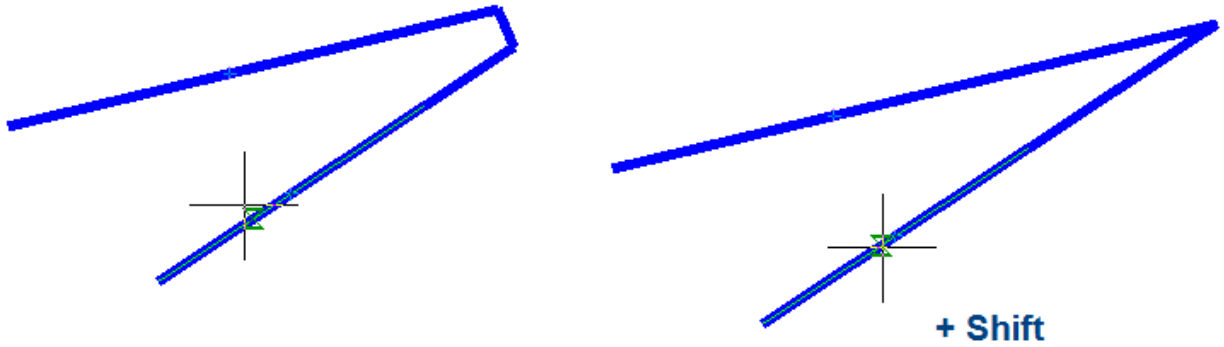

When making an insertion, a polyline retains its integrity.

If as a result of the command, one polyline is formed of two polylines, then it will be a single polyline object.

If you select segments of one polyline separated by other segments, then all these intermediate segments are deleted.

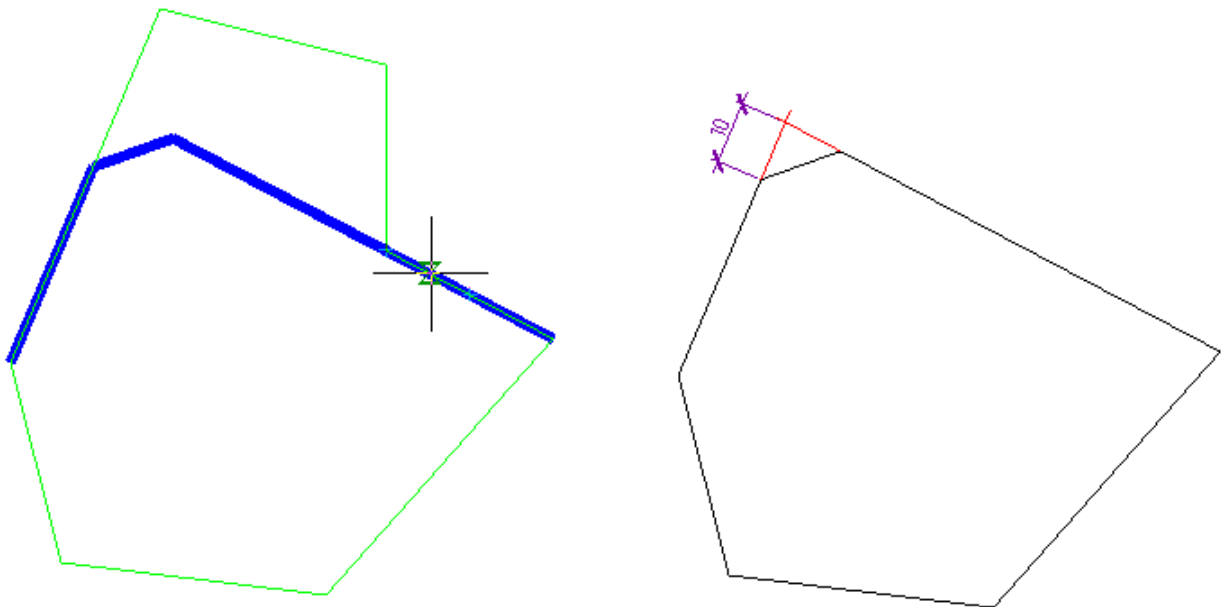

## Chamfer Command, Non-dialog Option



Command line: **CHA, CHAMFER**

Building chamfers using the command line.

Specify first line or [?/Undo/POLyline/Distance/ANgle/Trim/mEthod/Multiple]:

### Command options:

- ? Opens additional options for selecting objects.
- Undo Undoes the previous action in the command.
- POLyline Creates chamfers for all polyline vertices that are intersection points of two straight line segments. When the **Trim > Trim** mode option is set, the chamfer lines become new polyline segments.
- Distance Specifies the chamfer length from the intersection point of the first and the

second objects. If both values are zero, then the selected objects or line segments are lengthened or trimmed to the intersection point. You can specify the length in the drawing or by entering a value in the command line.

- ANgLe Specifies a chamfer along the length to the intersection point of the selected objects and the angle in the XY plane to the first object.
- Trim Controls the trimming of objects to chamfer lines.  
Trim – selected objects are removed to the end points of the chamfer lines. If objects do not intersect the chamfer line, they are extended or trimmed before the chamfer line is added.  
No trim – selected objects are not trimmed.
- mEthod Selects the chamfer construction method.  
Distance – specifies two chamfer lengths.  
Angle – specifies the length and angle.
- Multiple Adds a chamfer to multiple sets of objects.

### Command prompt:

Specify first line or  
 [?/Undo/Polyline/Distance/Angle/  
 Trim/mEthod/Multiple]:

Select the object or the desired option to set the parameters.

Specify second line or press  
 Shift to select or  
 [?/Distance/Angle/mEthod]:

Select the second object or use the **SHIFT** key to form an angle in the crosspoint. To change parameters, select the required option.

## Fillet

 Ribbon: **Home, Draw – Modify** >  **Fillet**

 Menu: **Modify** –  **Fillet...**

 Toolbar: **Modify** – 

 Command line: **MFILLET**

This command is used to create fillets in the intersection points of objects, with automatic dimensioning ability. The command can create fillets individually.

The **Fillet** command can be used for quick trimming or lengthening of selected objects. To do it, press **SHIFT** button when you select objects: a current value of fillet radius is temporarily changed to 0 and objects are lengthened or trimmed to intersection point.

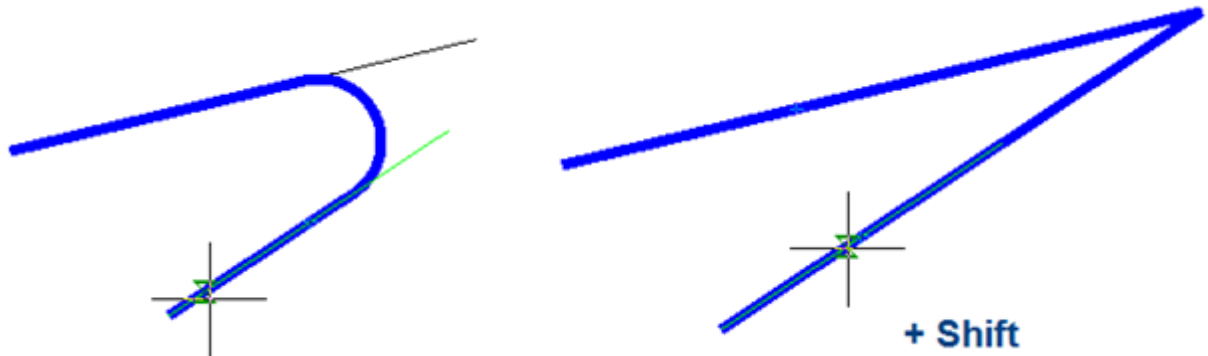

It is possible to make a fillet between parallel segments. A current value of fillet radius is temporarily changed to a value, which equals to half distance between parallel segments. The dialog box opens after the command is launched:

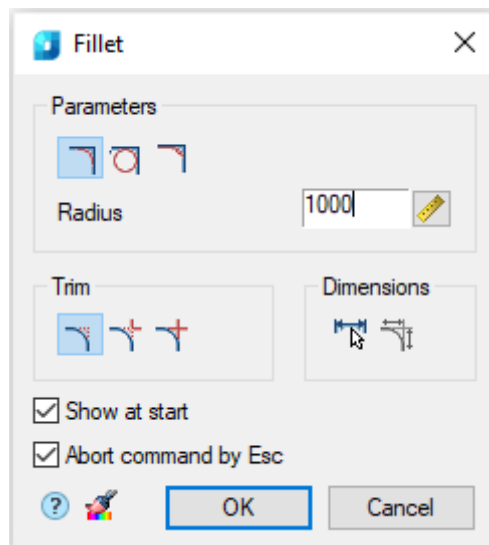

**Parameters:**



This button switches on the lines cutting mode.



This button switches to insert circle instead of fillet.

When performing an operation in this mode, the modes of dimensioning and complete or partial trimming of mating lines are ignored.

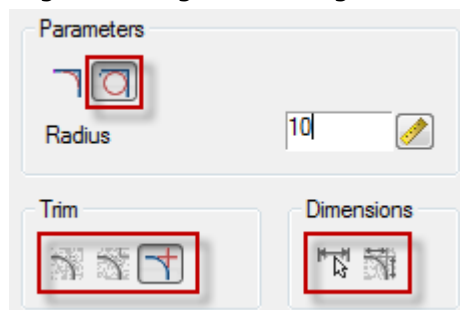

Button to enable fillet insertion mode as a mate.

**Radius**

Radius of fillet.



This button temporarily closes the dialog box to allow measuring of the fillet radius on the drawing. The **Value picker** dialog appears to perform measurements.



This button fully cuts lines before their intersection.



This button switches on the mode for cutting of lines before their intersection.



This button switches on the mode without lines cutting.



This button switches on the additional dimensioning mode.

The button becomes available when the  **Measure fillet** button is enabled.

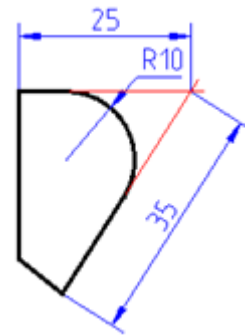

This button switches the automatic dimensioning mode on/off.



This button temporarily closes the dialog box to allow copying of properties from created fillets.

Double-click or right-click in the fields to enter values will open the context menu with the list of the recently entered values:

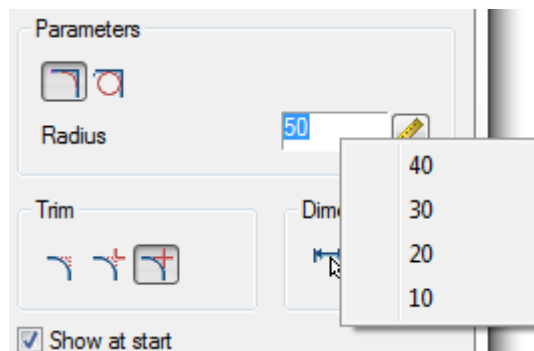

Options in the context menu and in the command line are available during the process of fillet creation:

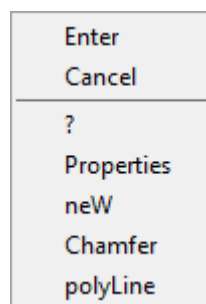

### Command options:

#### Properties

The **Fillet** dialog box opens to change the chamfer parameters.

#### neW

Finishes the creation of one group of fillets and starts another. The command is applied when you need to create some fillets with one

radius on one object and with the same radius on another object:

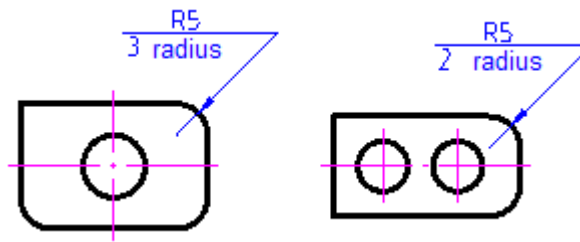

### Chamfer

Switches to the mode for creating chamfers. The **Chamfer** dialog box opens to specify the parameters of the fillet.

### polyLine

Switches to the mode of making fillets along a whole selected polyline. If a fillet radius does not equal zero the command creates fillet arcs for every node, created by crossed line segments, if they have a length enough for fillet creation.

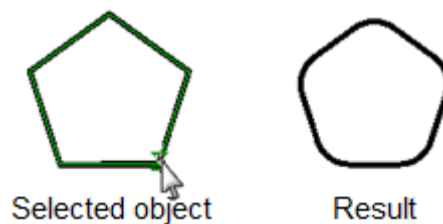

### Undo

Consecutive cancellation of previous actions, without exiting the command mode.

### To create a fillet:

1. Select the first object.
2. Move the cursor over the second object. Fillet options will be presented.
3. If there are no fillet options, select the **Properties** option from the context menu or the command line and adjust the radius.
4. Select the second object.
5. Select the fillet from the presented options.

### Features of the command work

The command works in 3D. To perform the command, the source entities should be located in the same plane.

If you press and hold **SHIFT** when selecting the second object, then a corner will be formed (closing in the intersection point and cutting off).

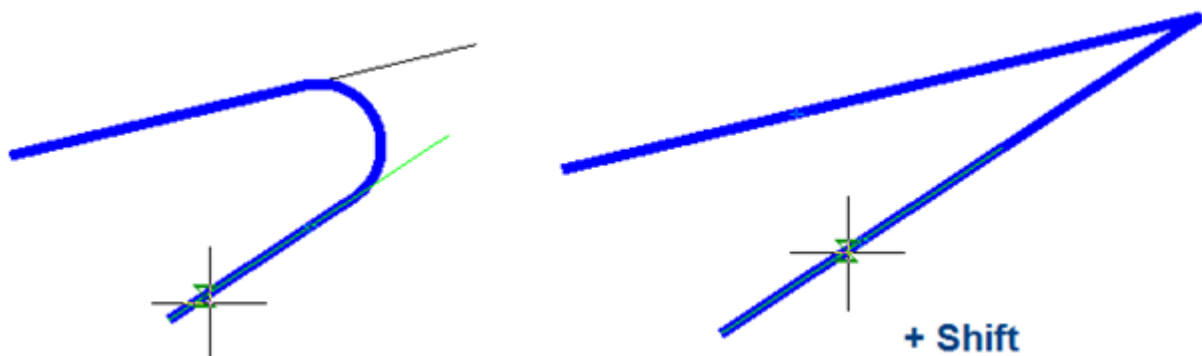

For pairs of objects LINE-ARC, ARC-LINE and ARC-ARC, two types of fillet are available: outside and inside ones.

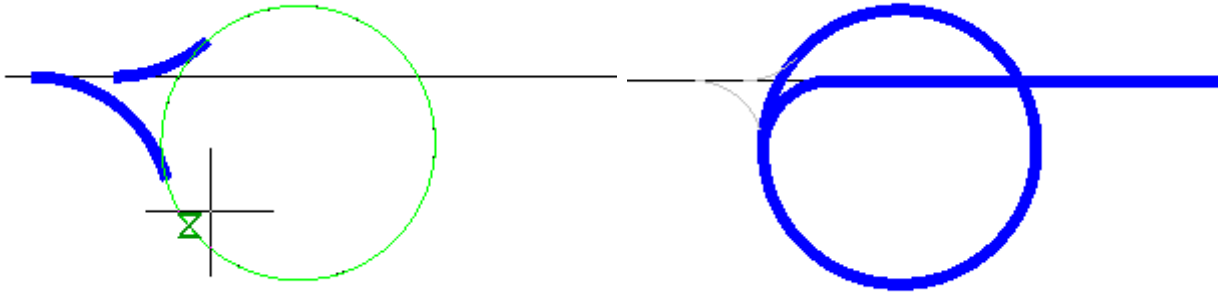

A fillet that combines inside and outside tangency is additionally available for ARC-ARC pair.

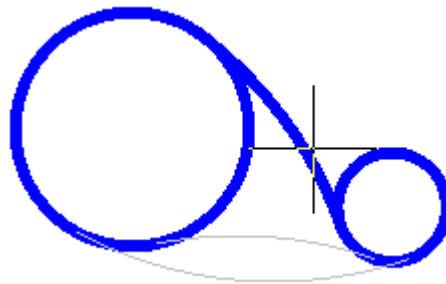

**NOTE:** Availability of different types of fillet depends on the fillet radius. Outside and combined fillets require larger radii than for inside fillets.

Selecting two parallel lines will create a fillet with a radius equal to half the distance between them (regardless of the specified Length). The sides will automatically align to the longest line.

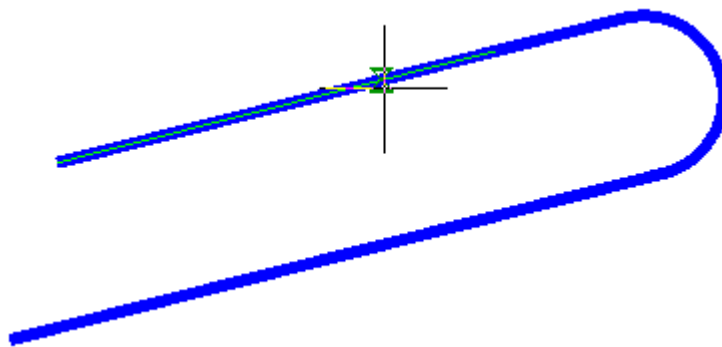

Fillet of parallel lines also works for segments of the same polyline.

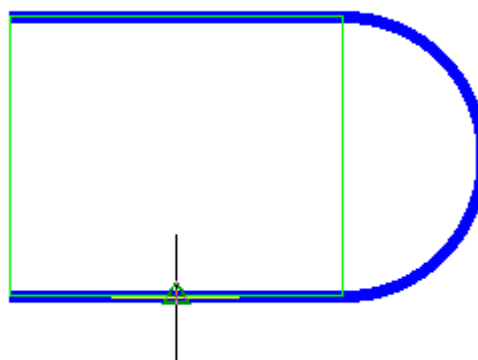

A fillet side depends on the mouse cursor position when the second object is selected  
When making an insertion, a polyline retains its integrity.

If one polyline is formed of two polylines as a result of the command, then it will be a single polyline object.

If segments of one polyline separated by other segments are selected, then all these intermediate segments are deleted.

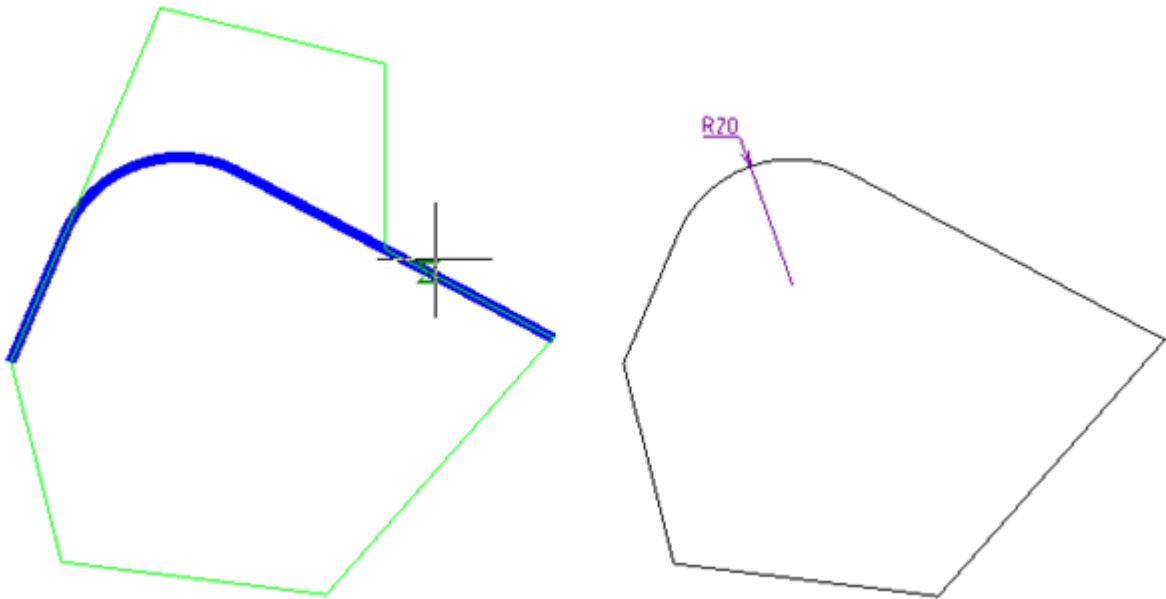

## Fillet Command (Non-dialog Mode)



Command line: **F, FILLET**

Creates a fillet using the command line.

### Command options:

<u>?</u>	Opens additional options for selecting objects.
<u>Undo</u>	Cancels a previous action in the command.
<u>POLyline</u>	Creates fillets for all polyline vertices which are the intersection points of two straight line segments. When the <b>Trim</b> option is enabled, fillet lines become new segments of polylines.
<u>RaDius</u>	Sets the fillet radius. When set to zero, objects are lengthened or cut to intersect.
<u>Trim</u>	Controls objects cut to fillet lines. <u>Trim</u> -selected objects are removed to the endpoints of the fillet lines. If the objects do not intersect with the fillet line, they are lengthened or clipped to the endpoints of the fillet line. <u>No Trim</u> - selected objects are not cut.
<u>Multiple</u>	Adds a fillet to multiple sets of objects.

### Command prompts:

Specify first object or  
[?/Undo/POLyline/RaDius/Trim/Multiple]:

Specify second object or Shift-select to apply corner or  
[?/RaDius]:

Select the first fillet object or the required option to set parameters.

Select the second fillet object or use **SHIFT** key to form an angle in the intersection point. To change



parameters, select the required option.

## Explode

 Ribbon: **Draw – Explode/erase >**  **Explode**

 Ribbon: **Home - Modify >**  **Explode**

 Menu: **Modify –**  **Explode**

 Toolbar: **Modify –** 

 Command line: **EXPLODE, X**

The **Explode** command divides complex objects, such as polylines, dimensions, hatches and blocks into separate elements. For example, dividing a polyline causes its separation into lines and arcs; an associative dimension divides into a set of simple objects; a block is divided into a set containing its objects; multiline text is divided into lines.

The **Explode** command is applied only to one nesting level of a complex object, i.e. if it is required to explode a polyline belonging to a block, firstly you have to explode the block and after that the polyline.

### Command options:

 Opens the additional options to select objects.

### Command prompts:

Select objects or [?]: Select an object.

Select objects or [?]: Select the next object and press **ENTER** to finish the command.

## Explode Geometry

 Ribbon: **Draw – Explode/erase >**  **Explode geometry**

 Menu: **Modify – Advanced Tools >**  **Explode Geometry**

 Command line: **EXPLODEGEOMETRY**

The **Explode geometry** command, as compared to the **Explode** command, splits complex objects into entities along the entire depth of the nesting levels. For example, it will explode several nesting blocks at once into their constituent segments, arcs, polylines without the need to repeatedly call the command.

### Command options:

 Opens additional options for selecting objects.

- Settings Changes the explode settings.  
The option opens the following prompt in the command line:  
Settings [Autoselect/Source/Properties/Text/Exit] <Exit>:
- Exit Exit from settings or the current settings section without changing the result.
- Autoselect Whether to put the results of command work in the selection (whether to create a post-selection upon the command completion).  
The option opens the following prompt in the command line:  
Autoselect results [Yes/No/Exit] <Exit>:
- Source Whether to erase source objects or not.  
The option opens the following prompt in the command line:  
Source objects [Erase/Keep/Exit] <Exit>:
- Properties Where to inherit properties of resulting objects: from the source object or set the current ones (based on values of CEXXX system variables).  
The option opens the following prompt in the command line:  
Specify object properties source [Original/Current/Exit] <Exit>:
- Text How to explode texts: create only boundary without filling \ with filling \ based on value of TEXTFILL variable.  
The option opens the following prompt in the command line:  
Specify text explosion mode [Boundary/Filled/Textfill/Exit] <Exit>:

### Command prompts:

- |  |   |
|--|---|
| Select objects or [ <u>?/Settings</u> ]: | Select the object.  |
| Select objects or [ <u>?/Settings</u> ]: | Select the next object or press <b>ENTER</b> to complete the command. |

After selecting the Exit option, an information message on all command settings will appear in the command line:

```
Command settings: *select* results, *erase* source objects, *current* object
properties, explode text as : *use TEXTFILL value*
```

## Explode All Objects



Ribbon: **Draw – Explode/erase** >  **Explode all selected entities**



Menu: **Modify –**  **Explode all objects**



Toolbar: **Modify –** 



Command line: **EXPLODEALL**

The command explodes all nanoCAD objects (notes, tables etc.) into primitives.

After explosion of objects you cannot apply nanoCAD special functions and editing commands to them.

# CREATING AND EDITING COMPLEX OBJECTS

## Groups of Objects

To edit a set of objects they can be grouped in the document. You can select the whole group and its elements to edit. New objects can be added to a group and existing objects can be excluded from a group. Objects can belong to several groups at once, and a group can belong to another group. To restore the configuration of source groups, grouped into one group, you have to ungroup nested groups.

Groups can be assigned names or use default names. An unnamed group (a group without its own name) has a default name -  $A_n$ , where  $n$  is the number of created groups.

A group name can contain up to 25 symbols and contain letters, figures and special symbols (dollar sign (\$), hyphen (-) and the break character (\_)).

Groups are saved with a document and can be used in the following working sessions.

Main distinction between groups and blocks:

- Objects in a group can be edited without ungrouping, but to edit objects in a block, the block must be exploded.
- A group cannot be transferred to another document; it can be used only in the document where it was created.

Commands to work with groups of objects are presented as:



Ribbon: **Home – Group**

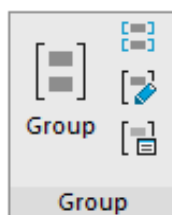

Toolbar: **Group**

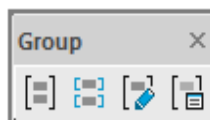

Menu: **Tools**



**Group** (GROUP,)

Creates a group of objects. Unlike the **New Group** option, GROUP allows creating both named and unnamed group.



**UnGroup**  
(UNGROUP)

Explodes or breaks a group.



**Editing a group**  
(GROUPEDIT)

Adds or removes objects from a group.



**Dialog for Creating Groups**  
(CLASSICGROUP)

Displays the **Object Grouping** dialog box to manage groups.

Commands to work with a group in the document's context menu:

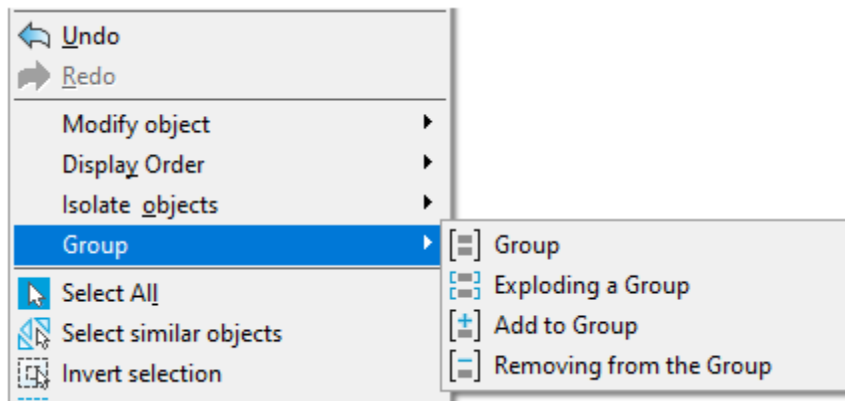

### Command to create a group of objects



Command line prompt:

Select objects or [?/Name/Description]

Command options:

Name	Set a group name.
Description	Enter description of a group of objects.

Selecting objects and pressing **ENTER** during the command will lead to creating an unnamed group. A prompt appears in the command line: `Anonymous (unnamed) group '*A1' was created.`

If objects in the drawing are preselected, the command will also create a group without name.

Unnamed groups are displayed in the **Drawing explorer**, by default they are assigned with the name `*An`, where  $n$  is a number increasing with each new group.

It is convenient to create, fill and edit groups using the [Drawing explorer](#) toolbar.

The [Object grouping](#) dialog box is intended for more detailed work.

## Using Drawing Explorer Bar to Work with Groups

The [Drawing Explorer](#) functional bar allows for full-value work with groups.

### Quick creation of a group

1. Select objects on the screen.
2. Call the context menu of the **Groups** section of the **Drawing Explorer** toolbar.
3. Select the **Create group from selection**. A group will be created and named `Group1`, where `1` is a sequence number of the created group.

### Editing a group

Edit commands are available in the context menu of the selected group.

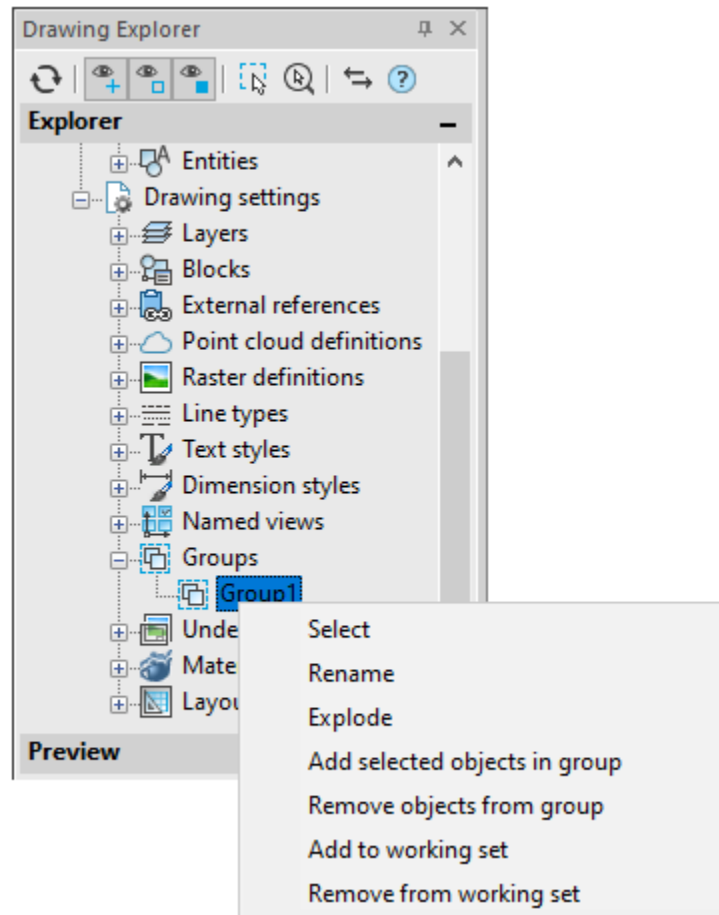

<b>Select</b>	Selecting and positioning the group's objects in the center of the screen.
<b>Rename</b>	Renaming the group.
<b>Explode</b>	Removing the selected group. Objects included in the group are not removed from the document.
<b>Add selected objects in group</b>	Adding preselected objects in a group.
<b>Remove objects from group</b>	Removing objects from the group selected in the workspace.
<b>Add to working set</b>	Adding all objects of the specified group in the current selection.
<b>Remove from working set</b>	Removing all objects of the specified group from the current selection.

To edit groups in the **Object grouping** dialog box, use the command of the context menu **Groups > Edit...**

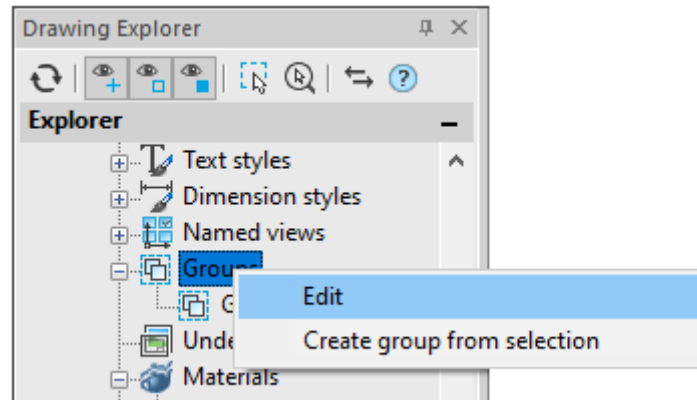

## Object Grouping Dialog

 Ribbon: **Home – Group** >  **Dialog for Creating Groups**

 Toolbar: **Group** –  **Dialog for Creating Groups**

 Command line: **G, CLASSICGROUP, GROUPCM**

The command opens the **Object Grouping** dialog box where there is a list with the names of existing groups in the document and descriptions for every group that is selectable:

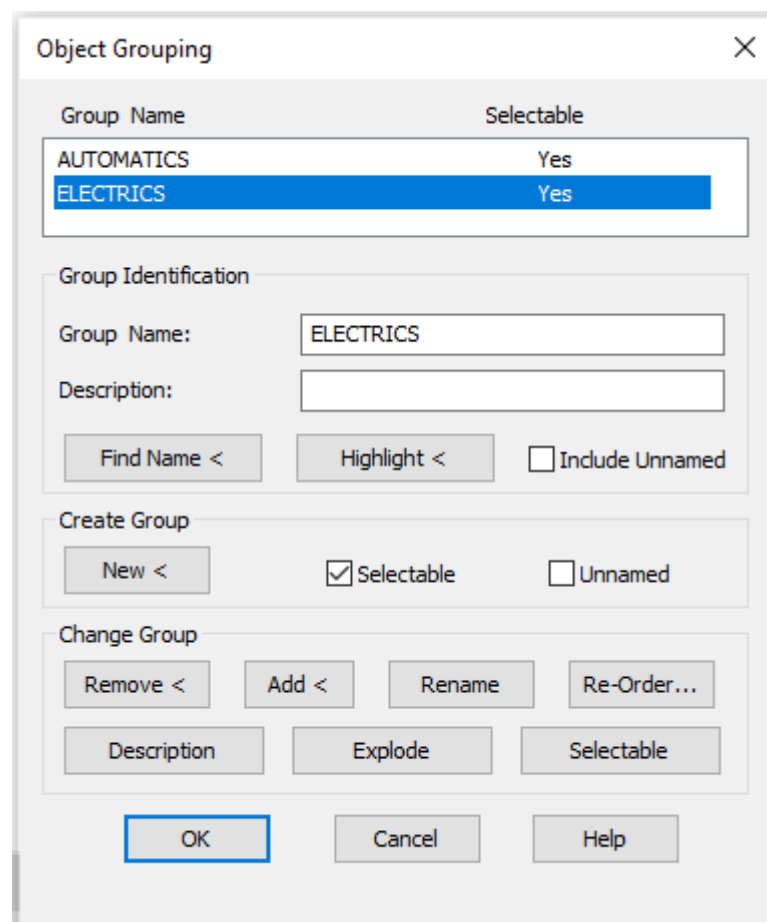

## Parameters:

### Group Identification

<b>Group Name:</b>	Specify a group name.
<b>Description:</b>	Displays the description of the group (if it was specified during group creation).

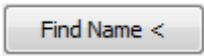
 This button temporarily closes the dialog box for selecting an object when you need to clarify its group.

 This button temporarily closes the dialog box for highlighting a group's objects on the screen.

**Including Unnamed** Switches on/off the input of unnamed groups in the list in the **Object Grouping** dialog box.

### Create Group

 This button temporarily closes the dialog box for selecting the objects of a group.

**Selectable** Switches on/off the mode of whole group selection if one object is selected.

**Unnamed** Switches on/off the mode for creating unnamed groups.

### Change Group

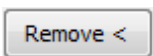
 This button temporarily closes the dialog box to allow selecting objects to delete from the selected group.

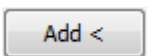
 This button temporarily closes the dialog box to allow selecting objects to add them to the selected group.

 This button updates a change of name for a group.

 This button opens the **Order Group** dialog box to change the order of objects in a group.

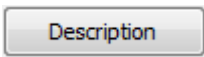
 This button updates the changed description for the selected group.

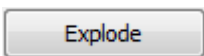
 This button deletes the selected group. Objects of the group are not deleted from the document.

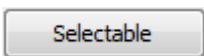
 This button changes the selectable property of a group in the document.

### To create a group:

1. Enter the name for the created group and its description in the **Group Name** and **Description** fields of the *Group Identification* section. A name can contain letters, figures and special symbols, but must not contain spaces. The **Description** field can be empty.
2. Select the **New** button to temporarily close the dialog box to select the objects of a group.
3. Select the objects, press **ENTER**.

4. Select **OK** in the opened dialog box.

**To identify a group:**

1. To define the groups the object belongs to, select the **Find Name<**.
2. After the dialog box temporarily closes, specify an object on the screen.
3. The **Group Member List** dialog box opens with all groups the selected object belongs to:

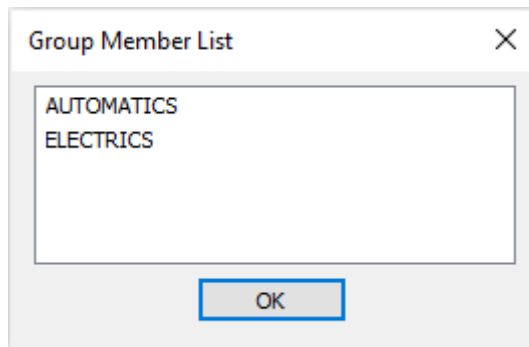

4. Select **OK** to get return to the previous dialog box.
5. Select **OK** to close the dialog box.

The **Highlight<** button temporarily closes the dialog box to allow highlighting of a group's objects on the screen. The **Object grouping** dialog box is displayed with the highlighted object:

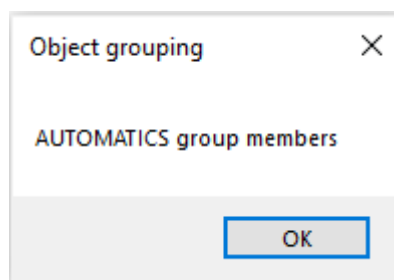

**To delete objects from a group:**

1. Select a group in the list.
2. Deselect the **Selectable** checkbox.
3. Select **Remove<**.
4. Select the objects to delete.
5. Select the **End** option (in the context menu or command line).
6. Select **OK** to close the dialog box.

**NOTE:** The description of the group is saved when all the objects are deleted from the group. To delete a group from a document, select **Explode**.

**NOTE:** When a group is deleted from a document, objects of the group are not deleted.

**To add objects to a group:**

1. Select group in the list.
2. Select **Add<**.
3. Select the objects to add.
4. Select the **End** option (in the context menu or command line).



5. Select **OK** to close the dialog box.

**NOTE:** When adding objects belonging to other groups to a group, the **Selectable** checkbox should be deselected. If it is selected, the groups that the objects belong to will be added to the group.

**To rename a group or change a description:**

1. Select the group.
2. Make changes in the **Group Name** and **Description** fields of the **Group Identification** section.
3. Select the Rename or Description.

The messages like **Group name** has been updated or **Group description** has been updated and are shown in the bottom left corner.

4. Select **OK** to close the dialog box.

**To change the order of objects in the group:**

1. Select the group.
2. Select **Re-Order**.
3. Specify the required parameters in the **Order Group** dialog box:

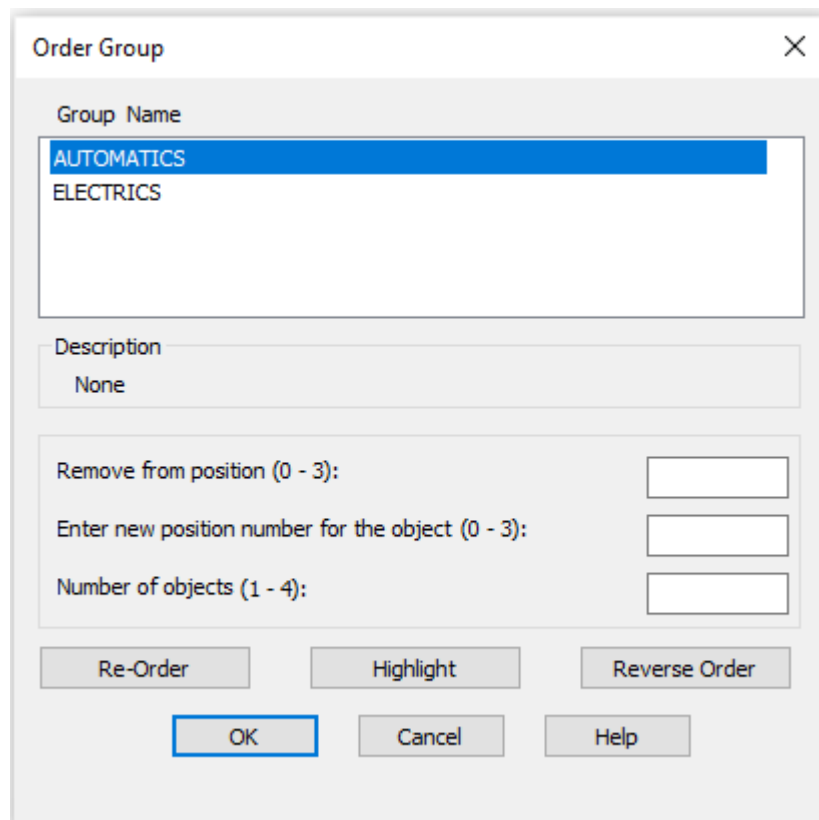

**Parameters:**

**Group Name**

List of existing groups.

*Description*

Shows the description of the selected group in the list (if it was specified when the group was created)

**Remove from position (0-3)**

Field to enter the current position (number) of the object in the group.

**Enter new position number for the object (0-3):**

Specifies the new position number of objects in a group.

**Number of objects (less than 4):**

Specifies the number of objects, whose positions are changed.

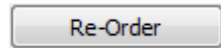

This button changes the positions of objects in the group.

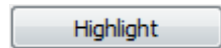

This button opens the **Object Grouping** dialog box to display the order of objects in the group.

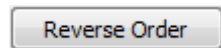

This button changes the objects into their opposite order.

**NOTE:** The order of object numbering is the order in which objects were selected when they were added to the group. Numbering starts from 0.

**NOTE:** You can change the positions of several objects at once.

The **Highlight** temporarily closes the **Order Group** dialog box and opens the **Object Grouping** dialog box:

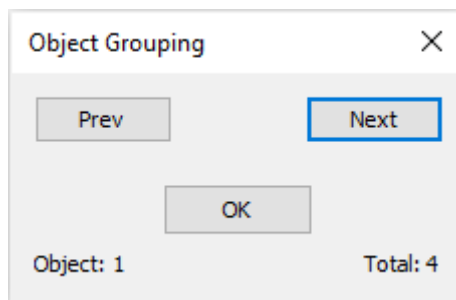

**Parameters:**

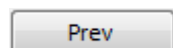

The button for the previous object selection.

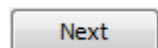

The button for the next object selection.

**Object: 1**

Shows the current position of the object in the group.

**Total: 4**

Shows the number of objects in the group.

**NOTE:** A selected object is highlighted on the screen.

## Blocks

A block is a collection of associated drawing objects processed as a whole entity. A block can be created of any number of objects and inserted in a drawing any number of times.

It is convenient to use blocks to create drawing elements for multiple use, thus accelerating and simplifying the drawing process.

Blocks can be used to create user libraries of frequently used parts and details.

Relating all references of a block to the same block description in the drawing database allows you to decrease the file size, as with every new insertion of a block, only information about the insertion place, scale factors and rotation angle is added to the information available.

A block creation implies its *definition* (description), which is stored in the block table of a document and is not displayed in a drawing. A block definition can contain links to other (nested) blocks. The only restriction to nesting blocks is that they cannot be inserted to themselves.

A block insertion in a drawing is called a block *reference* (block instance).

Any block description can have multiple references or not have any. When modifying a block description (or redefining a block), all its references are changed automatically.

An existing block (definition) can be changed by redefining it. After modifying a block definition, all references of this block in a document change automatically.

When a block is created, objects are placed in the block together with their current property values that cannot be changed without a block redefining. For example, if a block was created of red segments, it will be not possible to change segments color after the block is created. Therefore, it is required to take thought of the block behavior at its insertion in advance, i.e. at the stage of its creation.

### So that:

- *a block properties are defined by properties of a layer* it will be placed on, with assignment of color, linetype and lineweight of this layer to all objects included in the block, it is necessary to create all block objects on the 0 layer with assignment of color, linetype and lineweight **By layer**.
- *color, linetype and lineweight of block objects are defined at placing it in a drawing*, it is necessary to assign color, linetype and lineweight **By layer** to block objects when creating. In other words, block objects in this case inherit current values of color, linetype and lineweight. If current properties are not specified explicitly in a drawing, block objects will inherit properties of the current layer.
- *block objects retain their original properties*, i.e. always have certain color, linetype and lineweight, the respective properties should be explicitly specified before the objects are included in the block definition. In other words, when creating block objects in this case you should not use settings of color, linetype and lineweight **By layer** or **By block**.

When being created, a block can be attended with attributes, i.e. explanatory text, which is acceptable to change in the process of inserting the block in the drawing and which can be displayed on the screen or stay *invisible (hidden)* and is not printed out.

There are several ways to create and use blocks:

- It is possible to group objects and save them as a block in the current drawing (menu **Draw – Block > Create**);
- It is possible to save a block in a separate file to use it in other drawings by specifying **WBLOCK** command in the command line;
- It is possible to insert a drawing with available blocks as a reference to any other drawing (menu **Insert – Block, Open** button in the **Insert block** dialog box);
- It is possible to create a file with a set of frequently used blocks to use it as a library.



## Creating a Block



Ribbon: **Insert – Block Definition >**  **Create Block**



Ribbon: **Home – Block >**  **Create Block**

 Menu: **Draw – Block >  Make...**

 Panel: **Draw – **

 Command line: **ACADBLOCKDIALOG, B, BLOCK, BMOD, NEWBLOCK, NEWBL**

The **Create block** command is also available in the context menu.

The **Block definition** dialog box opened by the **Create block** command allows you to specify parameters for creating a new block or redefining the description of already existing block:

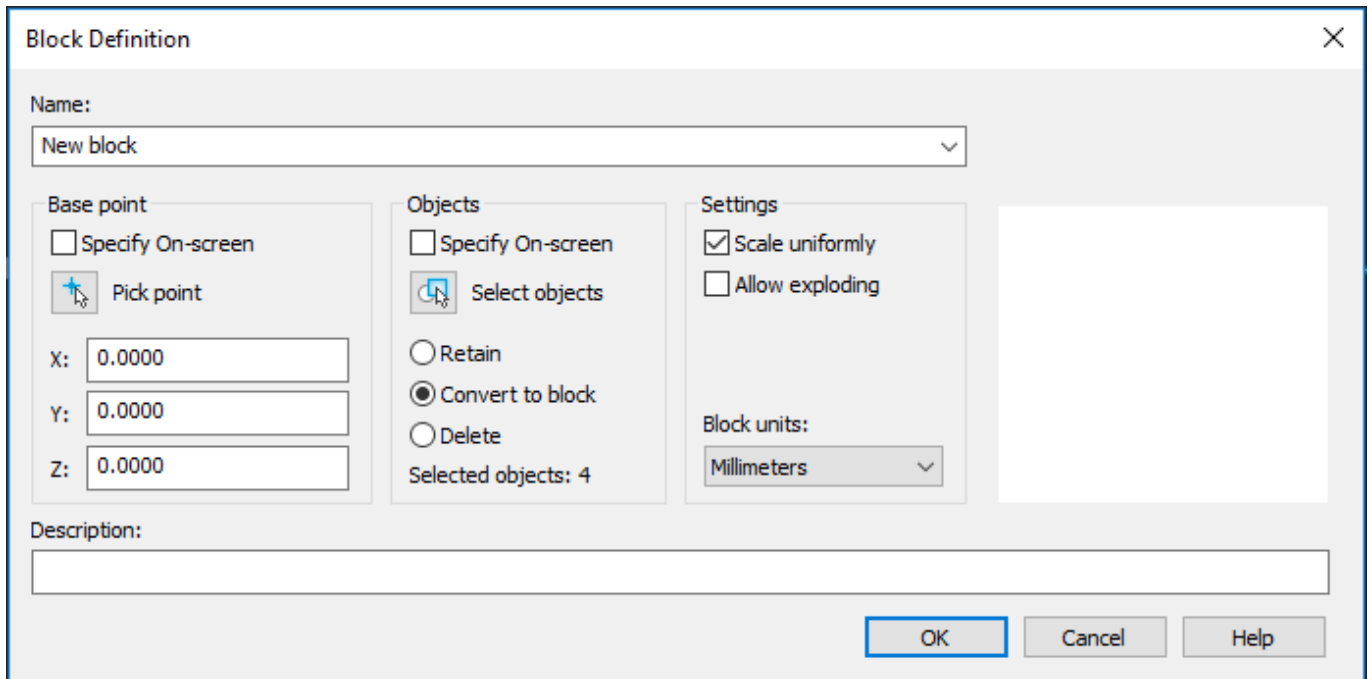

### Options:

**Name:** Names the block being created.  
To redefine the existing block, select the name from the drop-down list.

### Base point

**Specify On Screen** Turns on/off the mode for selecting the base point by cursor on the screen after the dialog box is closed.



**Pick point**

**X: Y: Z:** Fields to specify coordinates of the block insertion point.

### Objects

**Specify On Screen** Turns on/off the mode for selecting objects after the dialog box is closed.



**Select objects**

**Retain** Turns on the mode for retaining the selected objects in the drawing after the block is created.

**Convert to block** Turns on the mode for creating a block reference at the location of selected objects after the block is created.

**Delete** Turns on the mode for deleting the selected objects from the drawing after the block is created.

**Objects selected: 4** Displays information on the number of objects selected to create the block.

### Behavior

**Scale uniformity** Turns on/off the mode that specifies the uniform block scale by X, Y, Z axes.

**Allow exploding** Turns on/off the mode for breaking the block after it is inserted by the **Explode** command.

**Block units:** Drop-down list for selecting measurement units of the block being created.

**Description:** Field for entry of the text description (hidden attribute) to simplify future identification and search of the block.

**NOTE:** Objects included in the block being created can be selected in advance, before opening the Create block command.

## Block Insertion

 Ribbon: **Home, Insert – Block >**  **Insert**

 Menu: **Insert –**  **Block...**

 Panel: **Draw –** 

 Command line: **I, INSBL, INSERT**

A block insertion is also possible using the File Explorer functional bar.

The command inserts blocks or drawings (with \*.dwg or \*.dxf extension) in the current document.

If the rotation angle is specified, the point of its insertion is selected as the center of rotation. If the block's rotation angle is specified on the screen (by defining the point), the oblique angle of an imaginary line drawn from the specified point to the block insertion point is taken as the rotation angle.

After insertion in the drawing, the block is processed as a single object. To ensure the possibility to work with individual objects that form the block, it can be exploded during insertion by selecting the **Explode** checkbox in the **Insert block** dialog box, or after insertion by using the **Explode** command from the **Edit** menu.

To specify the parameters of the block being inserted the command opens the dialog box:

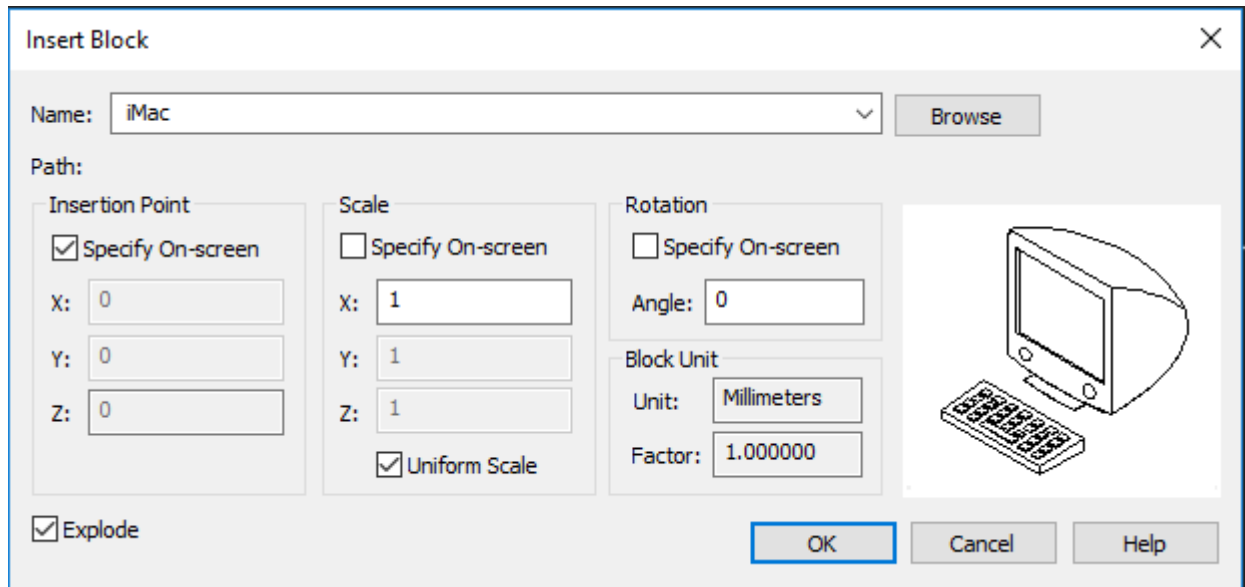

### Options:

- Name:** Drop-down list to select the name of the block being inserted. An empty list means that this document does not contain any block.
- Path:** Displays information about the path along which the block is located.
- Browse** Button to open a standard files selection dialog box, were it is possible to select a block or a file to insert in the document. Data of the file being inserted are copied into the table of blocks of the current document as the block definition.

### Insertion point

- Specify On Screen** Turns on/off the mode for selecting the block insertion point by cursor on the screen after the dialog is closed.
- X: Y: Z:** Fields to specify coordinates of block insertion point.

### Scale

- Specify On Screen** Turns on/off the mode for specifying the scale by cursor on the screen after the dialog is closed.
- X: Y: Z:** Fields to enter scale factors by X, Y, Z axes.
- Uniform scale** Turns on/off the mode of automatic application of the scale specified for X axis to Y and Z axes.

**NOTE** If, when inserting a block, you specify a negative scale value along any axis, the block will be mirrored relative to this axis.

**NOTE** For inserting blocks containing 3D the use of a non-unit scale is blocked. If you specify different values for **X: Y: Z:**, when inserting a block with 3D, the value 1 will be applied for all dimensions.

### Rotation angle

- Specify On Screen** Turns on/off the mode for specifying the block's rotation angle by cursor on the screen after the dialog is closed.
- Angle:** Enters the rotation angle for the block being inserted.

### Block units

- Unit:** Displays information on measurement units specified during the block creation.
- Factor:** Displays the scale factor calculated as the ratio of the block's measurement units to the drawing measurement units.
- Explode** Turns on/off the mode for exploding the block into component objects during insertion.

## Editing Block Definition (Block Redefinition)

Block definitions stored in a document can be modified. Change of a block definition (block redefinition) can influence not only on block references newly created in the current drawing, but also on already created, as well as on any attributes associated with this block.

Since there are two ways to insert blocks in the current drawing (both stored in a document, and from the external file), there are also two ways to redefine blocks:

- Block redefinition in the current document.
- External file change and its redefinition in the current document.

### Block redefinition in the current drawing

In most cases blocks are redefined in the Block Editor opened by the BEDIT command.

In addition, a block can be redefined manually by re-creating the block with the same name. To redefine the block manually, you should:

1. Insert the block in the drawing with its breaking into component objects by selecting the **Explode** checkbox in the **Insert block** dialog box or split the block reference available in the drawing by the **Explode** command from the **Edit** menu.
2. Edit the component objects.
3. Perform all actions to create a new block, but enter the name of the block being redefined.

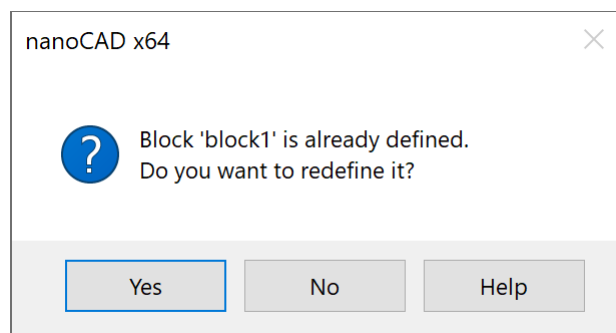

You can also redefine a block using the File Explorer functional bar. To do this:

Open the **File Explorer** functional bar (FILEEXPLORER).

In the tree of folders and files, select the drawing containing the block to insert.

3. In the right part of the file explorer window, open the context menu of the selected block. Select the **Insert and Redefine** or **Redefine only** option.

Immediately after the block redefinition all references of this block available in the drawing are updated automatically.

### Block redefinition from the external file

Block redefinition from the external file is performed similarly, if there is no necessity to change the external file.

Change of the external file has no influence on the current drawing, in which it is inserted as a block. To redefine (update) this block in the current drawing, it is necessary to insert it again.

### **Redefinition of block attributes**

When redefining blocks, it is possible to change the definitions of attributes included in them.

Change of attribute definitions while redefining blocks influences on block references already created in the current drawing as follows:

- New *variable* attributes do not appear in existing block references.
- Old *variable* attributes remain in the existing block references, even if the redefined block does not have attributes at all.
- New *constant* attributes in the existing block references are added to the old ones.
- Old *constant* attributes (having fixed values) will be lost, if the redefined block has no attributes at all, or replaced by new values specified for the redefined block.

## **Block Editor**



Ribbon: **Home – Block** >  **Block Editor**



Ribbon: **Insert – Block Definition** >  **Block Editor**



Menu: **Tools** –  **Edit block definition...**



Toolbar: **Main** –  **Edit block definition...**



Double-click on the block reference



Command line: **BEDIT**

This command allows you to edit block definitions of a drawing – to redefine blocks.

The command opens the **Edit block definition** dialog box.

Select in the list the block definition to be edited. If the **Zoom to block** box is checked, the selected block's insertion will be displayed on the screen.



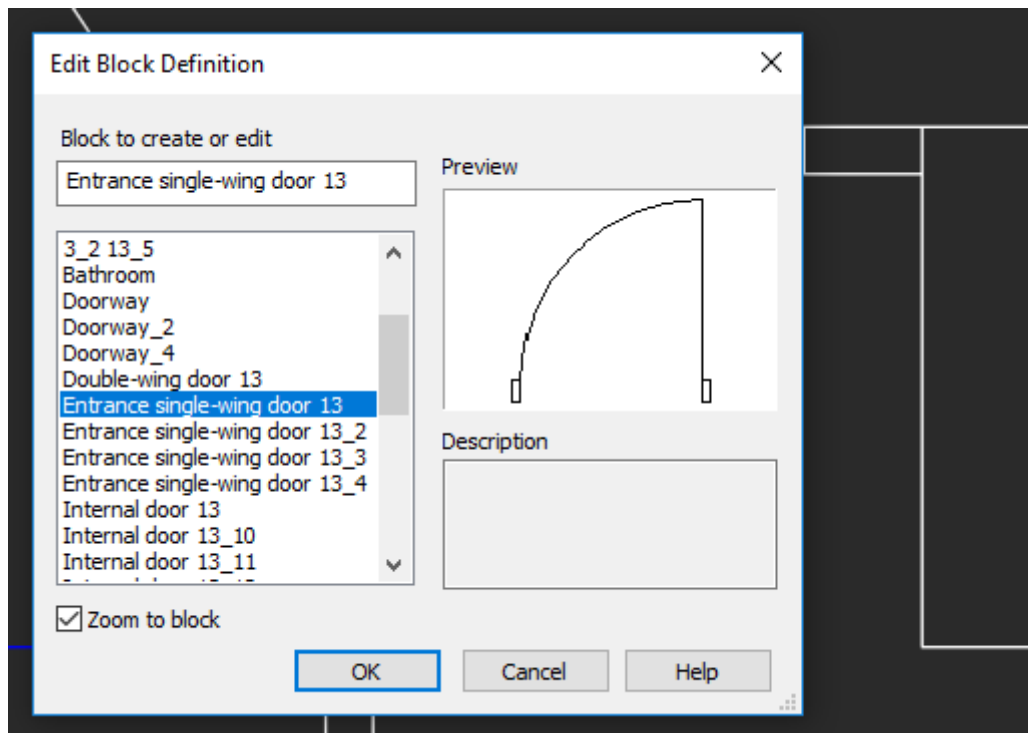

**Options:**

**Zoom to block**

Turns on/off the mode for full screen display of the selected reference.

Click **OK** to move to the block editor.

The block editor is a separate mode intended for editing a block definition.

Objects included in the selected block definition are displayed on the screen and become available for editing, and the additional **Block Editor** tab appears in the ribbon.

**NOTE:** If objects are not visible, double-click the mouse wheel to perform the **Show all** command.

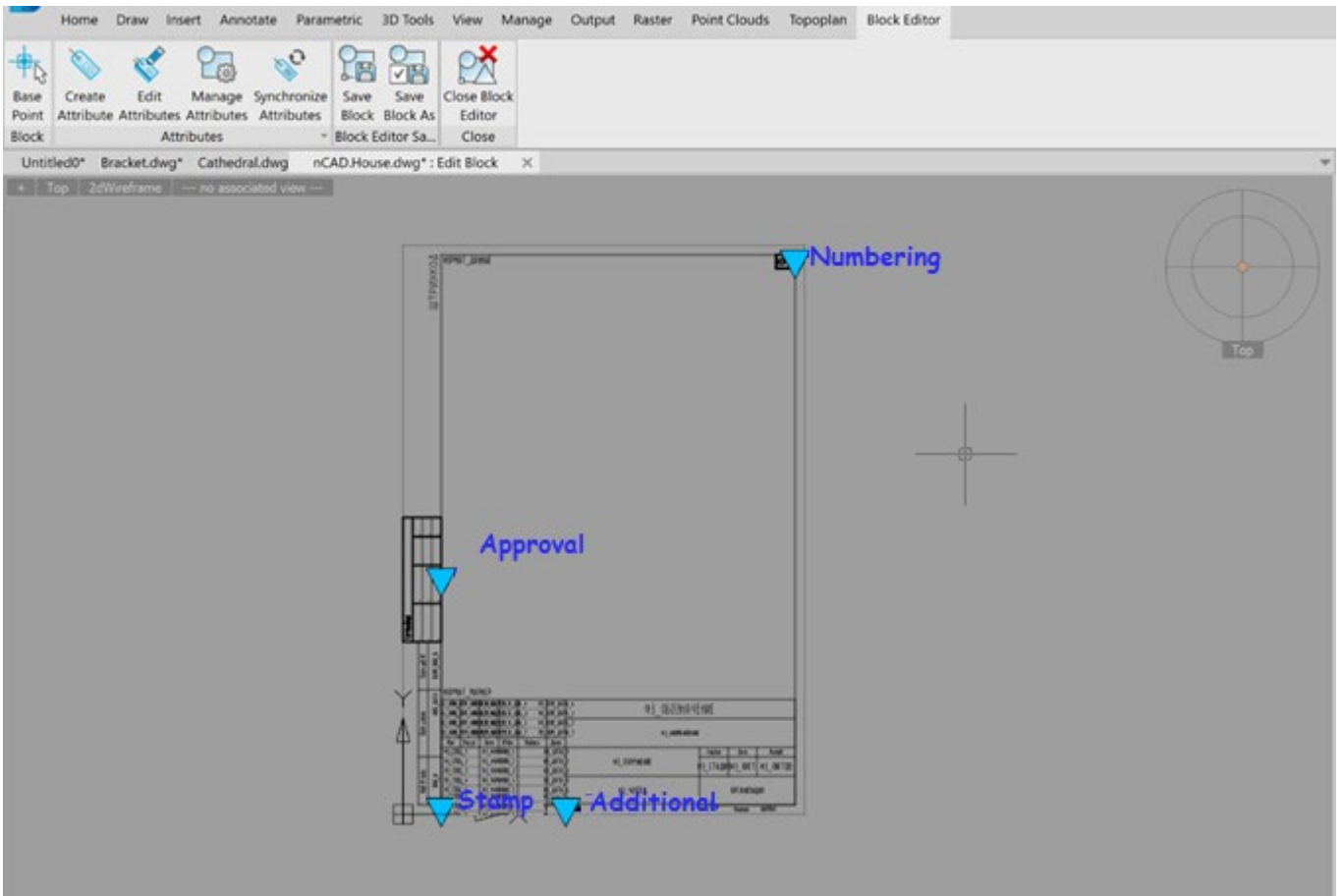

To indicate the mode of editing block definition, a word combination *Edit block* is added with a colon in the tab to the document name.

Background color changes to the color set in the **Tools** dialog, section **Color** > **Block editor background**.

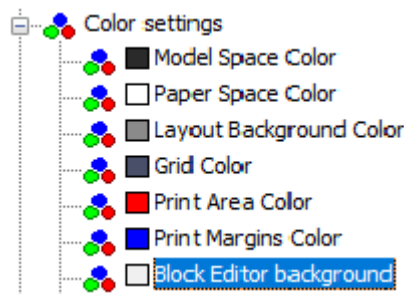

The additional **Block Editor** context tab with additional tools to edit a block and the button to exit the edit mode appears in the ribbon.

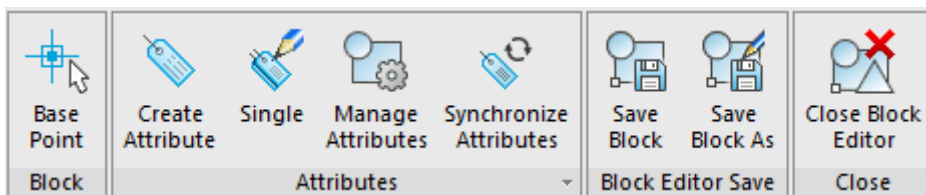

In the classic interface – the **Block Editor** toolbar appears:



**NOTE:** A number of platform commands is unavailable in the block definition edit mode.



The **Base Point of the Block** (BBASEPT) command specifies the position of the block definition base point. Corresponds to the grip position of the block reference insertion point.

### Completion of work



The **Save block** command (BSAVE) saves changes made in the block editor. Do not click if you plan to exit the block editing mode without saving changes.



The **Save Block as** command (BSAVEAS) saves a copy of the block definition being edited with a new name.

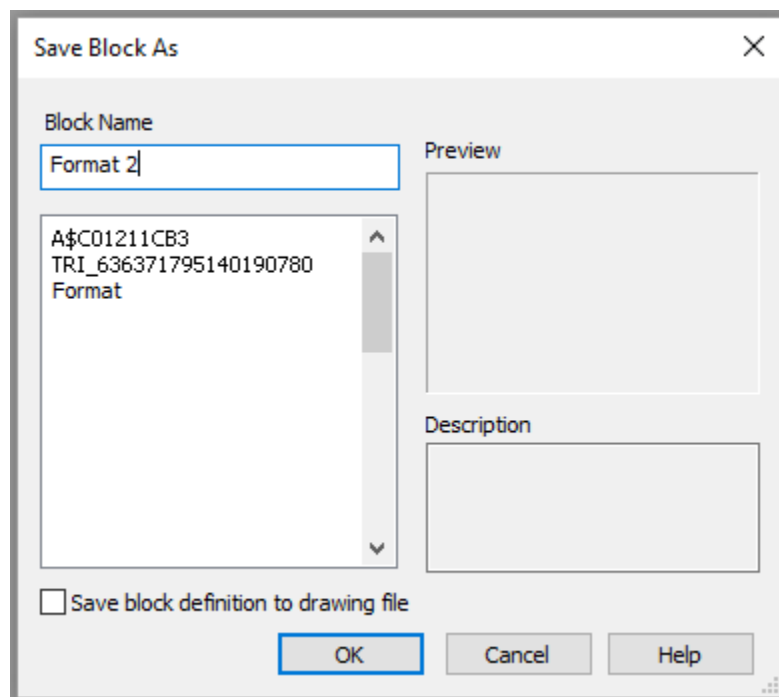

Upon the completion of editing a block, leave the editing mode using the **Close Block Editor** command (BCLOSE). You will be prompted to save changes.

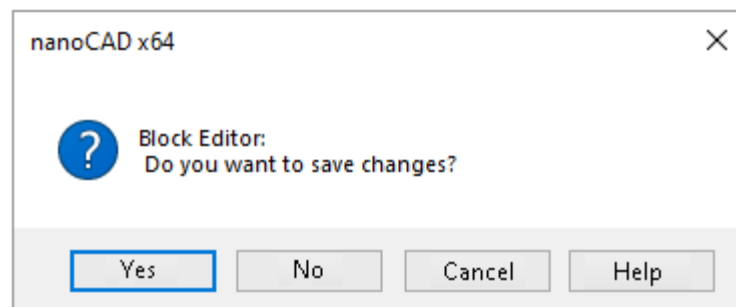

## 3D Block Editor





Ribbon: **Home – Block** >  **Edit 3D Reference**

 Ribbon: **Insert – Block Definition >**  **Edit 3D Reference**

 Menu: **Tools –**  **Edit 3D Reference ...**

 Toolbar: **Main –**  **Edit 3D Reference ...**

 Double click on a 3D block reference

 Command line: **3DBEDIT**

The command allows you to edit definitions of 3D blocks of the drawing - blocks containing solid objects (3D solids) or parametric bodies.

The command opens the **Edit 3D Reference** dialog box.

Select the block definition you want to edit from the list. If the **Autopan** box is checked, the insertion of the selected block will be displayed not only in the **Preview** dialog window, but also in the workspace on the screen:

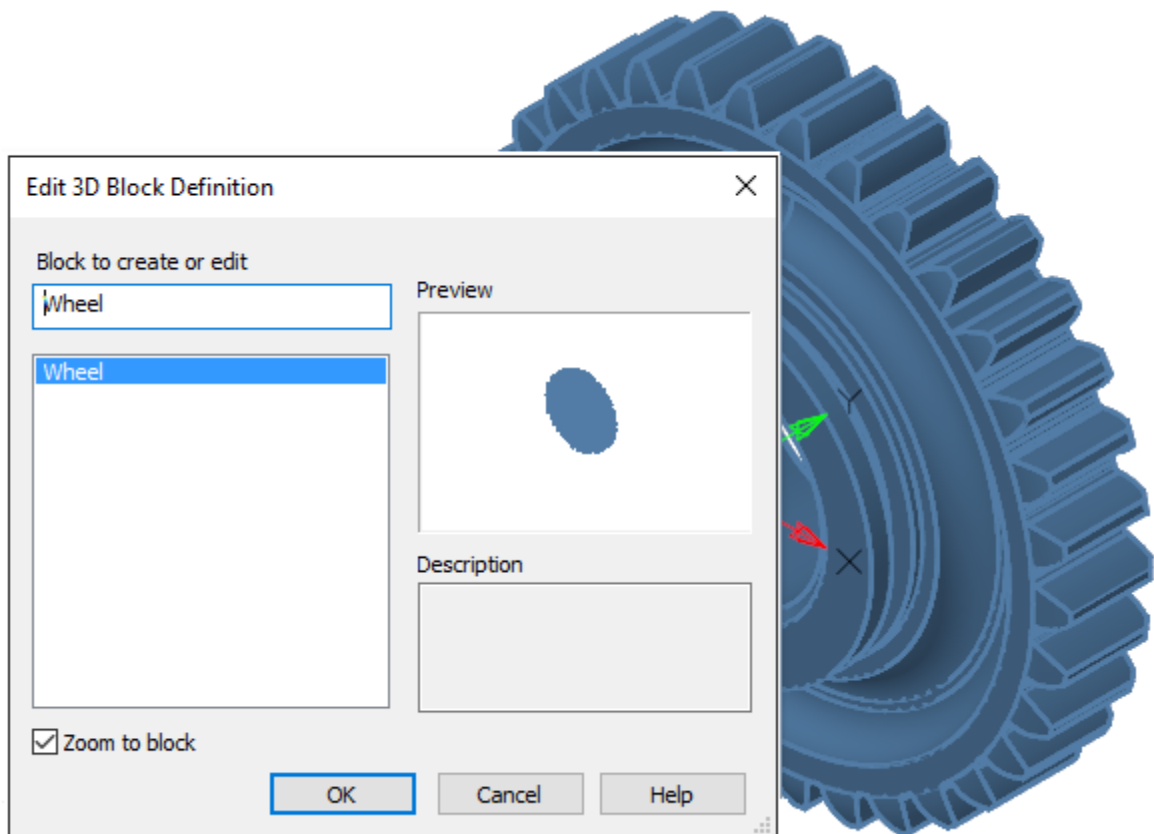

### Options:

#### Autopan

Turns on/off the mode to display the selected reference in full screen.

Click **OK** to go to the 3D blocks editor.

The background color changes to that specified in the **Options** dialog in the **Color settings > Block Editor background** section.

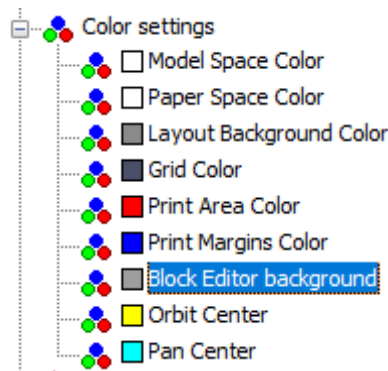

The 3D Block Editor is a separate mode for editing the 3D block definition. Objects included in the definition of the selected block are displayed on the screen and become available for editing.

An additional **3D Block Editor** tab with additional tools for 3D editing, buttons for saving changes and exiting the edit mode appears on the ribbon.

**NOTE:** The ribbon's context tab of the 3D Block Editor lacks a number of commands that are present in the standard block editor (BEDIT), for example, for work with attributes. However, these commands can still be called from other ribbon tabs, menu, or command line.

**NOTE:** If there is no license for 3D module, editing 3D blocks by standard methods will still be available, but without the possibility to use 3D editing commands.

To edit references, use the 3DREFEDIT command.

## Block Attributes

A block attribute is used to associate text information or any other data called *attribute value* with a block.

When inserting a block with *variable* attributes, it is supposed to enter the attribute value, which is then saved together with the block. Different values can be assigned to the attribute when inserting one and the same block.

*Constant* attributes, the values of which do not change at blocks insertion, can also be used in blocks.

Attributes can be *invisible*, they are not displayed on the screen and are not printed out.

Attributes can be *single-line* and *multiple-line*. Single-line attributes have a limitation – 255 characters. Different editors are used to edit single-line and multiple-line attributes.

Information stored in attributes can be exported to electronic tables or databases for further processing and generating a variety of documents, for example, schedules or bills of materials. It is acceptable to associate several attributes having different names with one block.

Attributes for inclusion in a block should be created before the block definition.

Type of **Text formatting** toolbar when creating and editing *multiple-line* attributes depends on **ATTIPE** system variable.

**ATTIPE = 0** - Displays the abbreviated Text Formatting toolbar:



**ATTIPE = 1** – Displays the full **Text Formatting** toolbar:

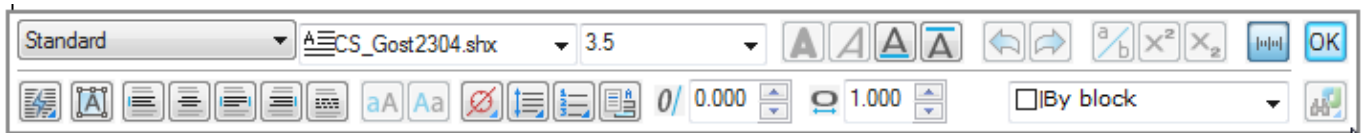

The information stored in attributes can be exported to spreadsheets or databases for further processing and generating a wide variety of documents, such as specifications or lists of materials. It is allowed to associate several attributes with different names with one block.

The attributes to be included in the block should be created before the block is defined.

## Creating Block Attributes



Ribbon: **Insert – Block Definition >**  **Define Attributes**



Menu: **Home – Block >**  **Define Attributes**



Menu: **Draw – Block >**  **Define attributes...**



Panel: **Draw –** 



Command line: **ATT, ATTDEF**

To define attribute parameters, open the **Attribute definition** dialog box.

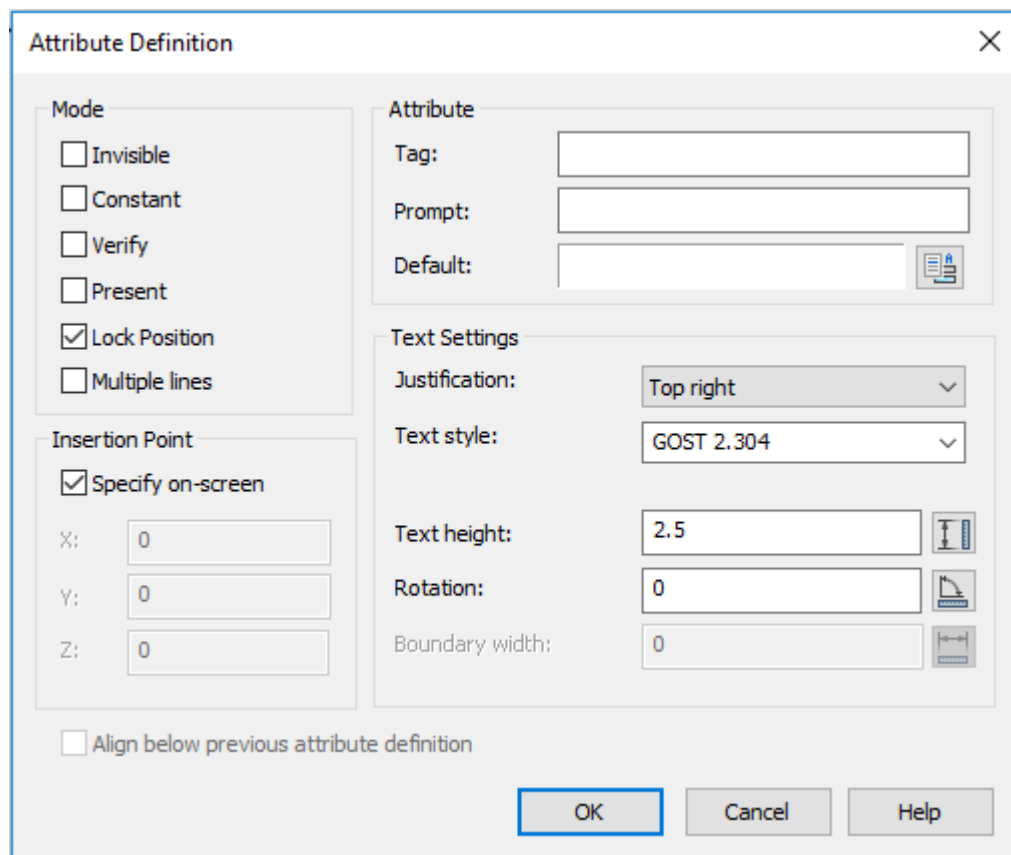

### Options:

#### Mode

#### Invisible

Turns on the mode at which the attribute value is not displayed on the screen and is not printed out.

<b>Constant</b>	<p>Turns on the mode that assigns a fixed value for the attribute for all block references.</p> <p>When inserting a block with the attribute having a constant value, this value is not requested.</p> <p>If the attribute has a variable value, this value is not requested during the block insertion.</p>
<b>Verify</b>	Turns on the mode of verifying the attribute value during the block insertion.
<b>Preset</b>	Turns on the mode that assigns the default value to the attribute during the block insertion.
<b>Lock position</b>	Turns on the mode that locks the location of the attribute within the block reference. When the mode is unlocked, the attribute can be moved relative to the rest of the block using grip editing.
<b>Multiple lines</b>	<p>Turns on the mode that creates the value of attribute containing multiple lines of text.</p> <p>When the mode is unlocked, the field for text entry is active for the <b>By default</b> parameter.</p> <p>When the mode is turned on, text entry field is blocked, the button  and the <b>Boundary width</b> parameter are enabled</p>

#### Attribute

<b>Tag:</b>	<p>Defines the attribute name.</p> <p>The name can consist of any characters except spaces.</p>
<b>Prompt:</b>	<p>Field to enter the prompt text displayed at request of the attribute value while inserting the block containing this attribute. If the field is empty, the attribute tag is used as a prompt.</p> <p>When the <b>Constant</b> mode is enabled, the field is blocked.</p>
<b>Default:</b>	Field to enter the default attribute value. The field can be empty.
 <b>Insert field</b>	<p>Opens the <b>Field</b> dialog box to insert the field with a default value. The field is automatically updated with changes of value associated with it.</p>

#### Insertion point

<b>Specify On Screen</b>	After the dialog box is closed, it will be proposed to specify on the screen the attribute insertion point in the block.
<b>X: Y: Z:</b>	Accurate coordinates of the attribute insertion point by three axes.

#### Text settings

<b>Justification:</b>	Drop-down list to select the type of justification of the attribute text.
<b>Text style:</b>	Drop-down list to select the text style.
<b>Text height:</b>	Field to enter the text height.
<b>Rotation:</b>	<p>Field to enter the rotation angle of the text.</p> <p>For <b>Fit in</b> and <b>By width</b> align options for single-line attribute the <b>Rotation</b> option is not available.</p>
	Buttons that temporary close the dialog box to specify on the screen by mouse cursor the text height, text rotation angle or boundary width for multiple-line attribute.

<b>Boundary width</b>	<p>Specifies the maximum value of lines length in a multiple-line attribute, at exceeding which the text is automatically wrapped to another line.</p> <p>When the value is 0, there is no restriction on the length of a line.</p> <p>The option is not available for creating single-line attributes.</p>
<b>Align below previous attribute definition</b>	<p>Ensures placement of this attribute tag directly below the previous attribute tag. When the flag is checked, the text options of the current attribute will be fully copied from the previous attribute. This option is not available at the first attribute definition.</p>

**To create a multiple-line attribute:**

1. In the **Attribute definition** dialog box, to check the **Multiple lines** flag.
2. Define the attribute name, prompt, insertion point, modes and text options.
3. If necessary, enter the value in the **Boundary width** field.
4. Click the button  to open the context editor to specify the format of multiple-line attribute in the drawing.
5. Specify the left upper position of the multiple-line attribute in the drawing.
6. After the text entry is completed, click **OK** button in the **Text format** dialog box to return to the **Attribute definition** dialog box.
7. Click **OK** to close the **Attribute definition** dialog box.
8. Specify the attribute insertion point in the drawing (if the **Specify On Screen** is checked for the insertion point).

After the attribute is created, it can be included in the set of objects in creating a block, i.e. in response to the query on objects selection in creating a block, it is necessary to select not only geometric objects, but also attributes. The attributes selection procedure determines the order of queries on entering attribute values when inserting the block.

It is also possible to associate the attribute with the block during the block redefinition.

**Example of the "Table\_title" attribute meaning "WARNING" (plate view and information displayed in Properties box):**



Before the attribute insertion in the block

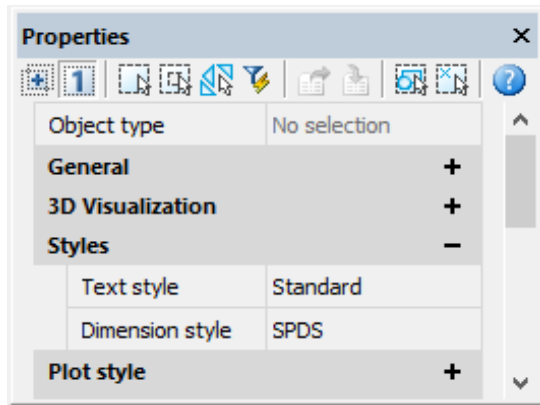

After the attribute insertion in the block

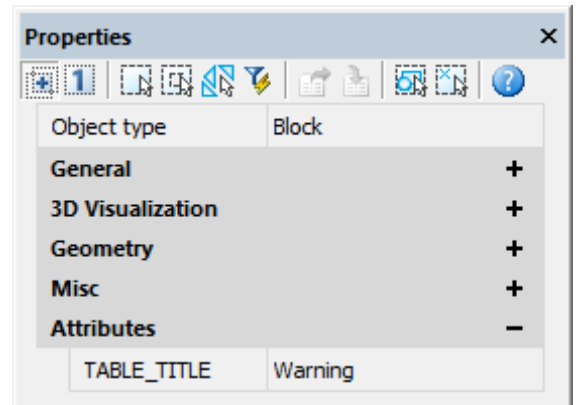
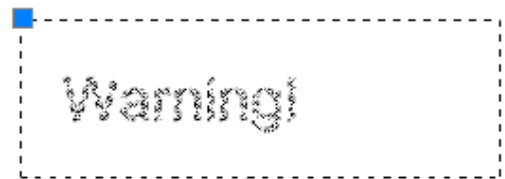

## Editing Values of Attributes in a Block Reference



Menu: **Modify – Object > Attributes >**  **Edit block attributes ...**



Toolbar: **Edit 2** – 



Command line: **ATTEDIT**

The command opens the **Edit of attributes** dialog box, where it is possible to change attribute values of the block reference specified in the drawing:

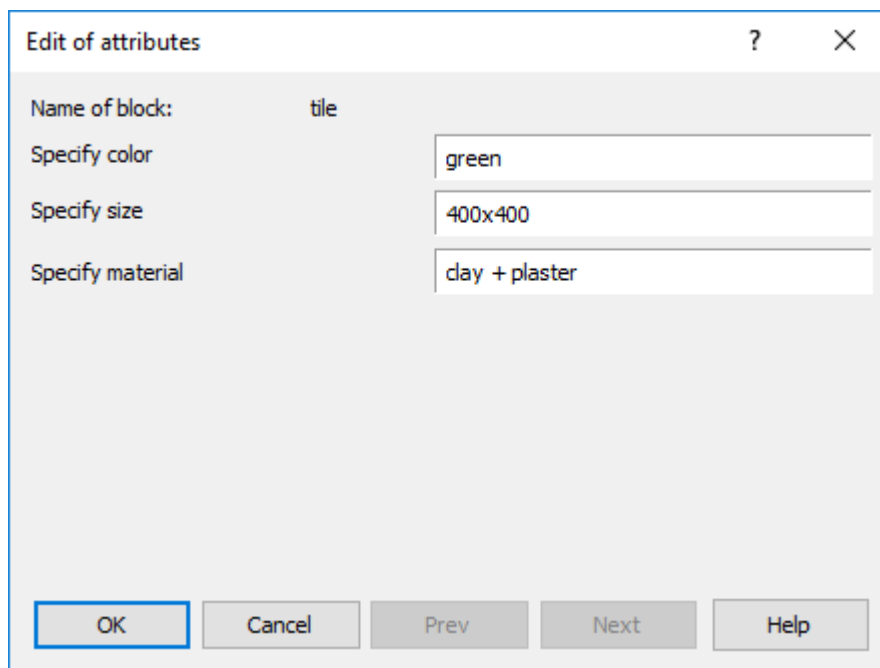

The dialog box displays the block name, prompts and enables to edit values of all attributes contained in the block reference.

Attribute values of the selected block reference can also be changed on the **Properties** functional panel in the **Attributes** section:

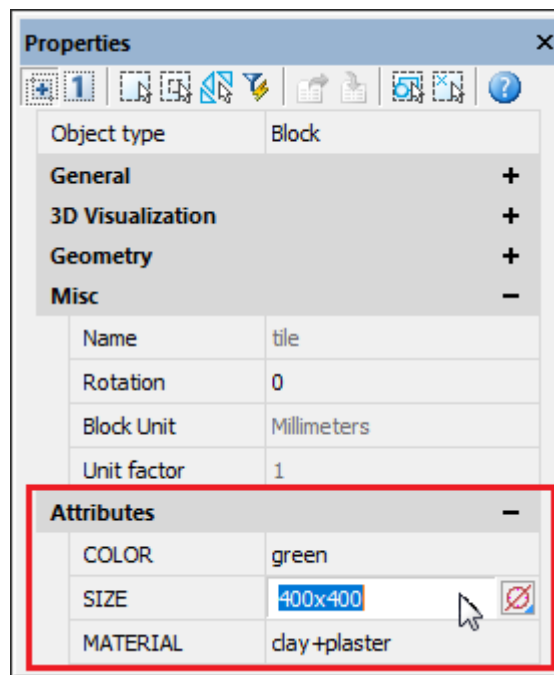

## Editing Attributes of a Block Reference



Ribbon: **Home, Insert – Block** >  **Single...**



Menu: **Edit – Object** > **Attributes** >  **Enhanced attribute editor ...**



Panel: **Edit 2** – 



Command line: **EATTEDIT**

Enhanced attribute editor allows you to edit the values, text options and properties of attributes in the selected block reference.

The **Enhanced attribute editor** dialog box displays the information:

**Block:** - name of the block whose attributes are being edited;

**Tag:** - name of the attribute being edited.

The **Select block** button allows you to select the block on the screen to edit attributes. The dialog box temporarily closes.

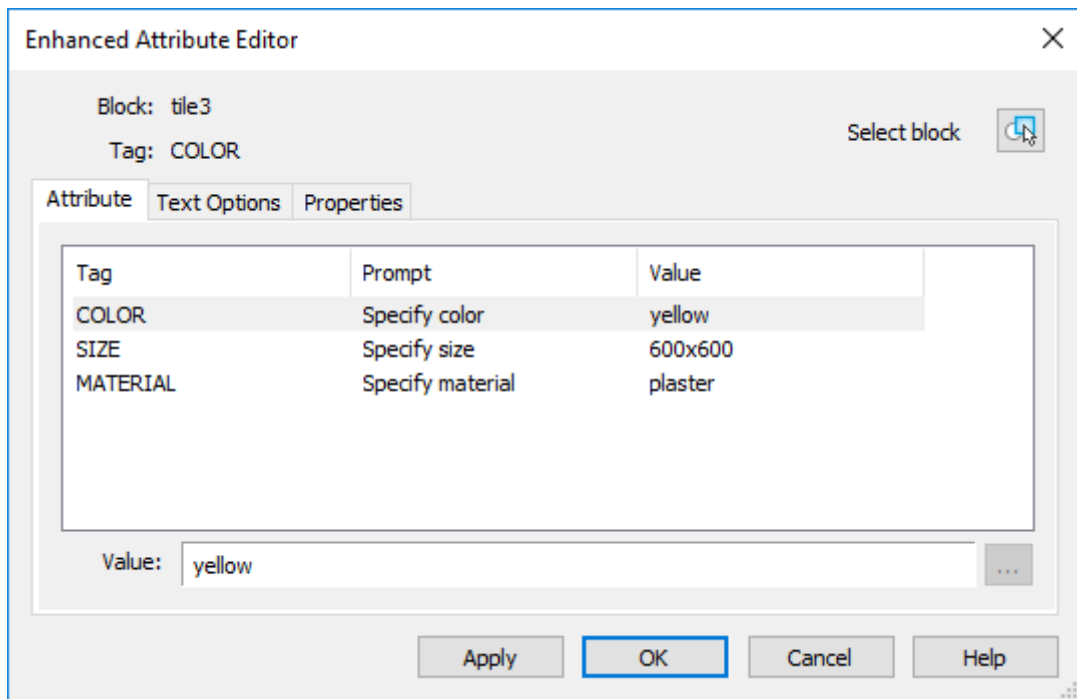

The **Apply** button is used to review all changes made without closing the **Enhanced attribute editor** dialog box.

#### **Attribute tab**

The tab contains the list of all attributes of the selected block and displays the following parameters for each attribute: **Tag**, **Prompt** and **Value**.

An attribute value can be changed in the **Value** field.

#### **Text options tab**

The tab sets the options for display of the attribute text in the drawing.

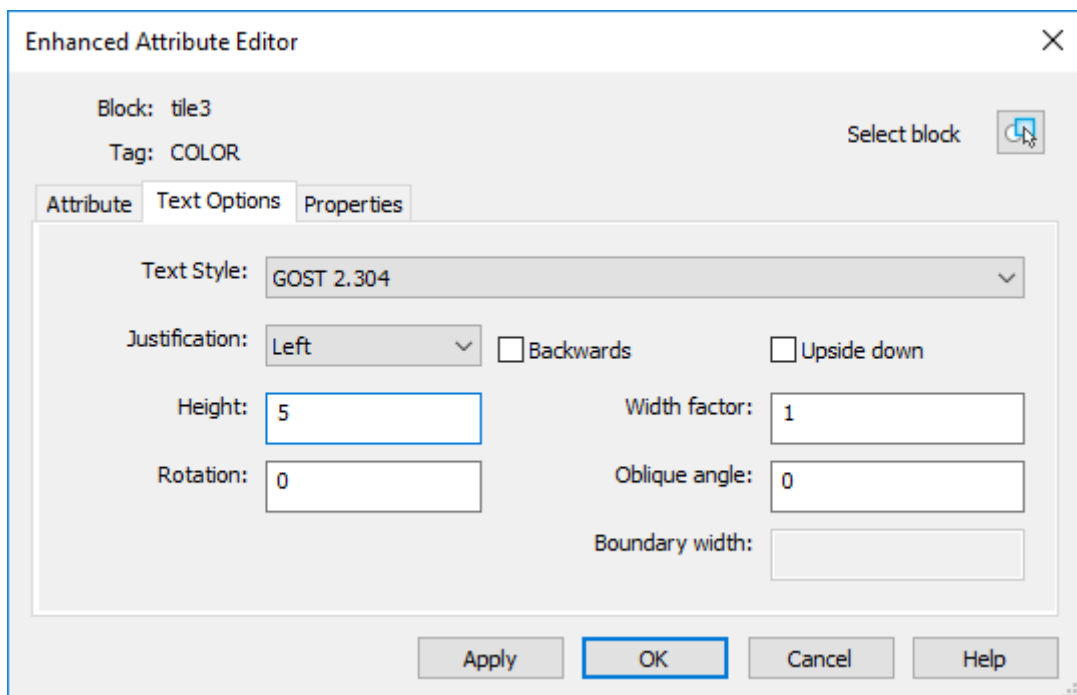

#### *Options:*

##### **Text style**

Drop-down list to select the text style.

##### **Justification**

Drop-down list to select the type how the attribute text is justified.

<b>Height</b>	Field to enter the text height.
<b>Rotation</b>	Field to enter the rotation angle of the text.
<b>Backwards</b>	Turns on/off the mode of displaying the attribute text from right to left. The option is not available for multiple-line attributes.
<b>Upside down</b>	Turns on/off the mode of displaying the attribute text upside down. The option is not available for multiple-line attributes.
<b>Width factor</b>	Specifies the degree of condensing/expanding the attribute text. Setting the value less than 1 condenses the text. Setting the value greater than 1 expands it.
<b>Oblique angle</b>	Angle of the text slant. Is measured relative to the vertical axis. The option is not available for multiple-line attributes.
<b>Boundary width</b>	Specifies the maximum value of lines length for a multiple-line attribute; when it is exceeded, the text is automatically wrapped to the next line. A value of 0 means there is no restriction on the length of a line. The option is not available for single-line attributes.

### Properties tab

The tab defines the **Layer** that the attribute is on, specifies the **Lineweight** and **Linetype**, as well as **Color** for the attribute text.

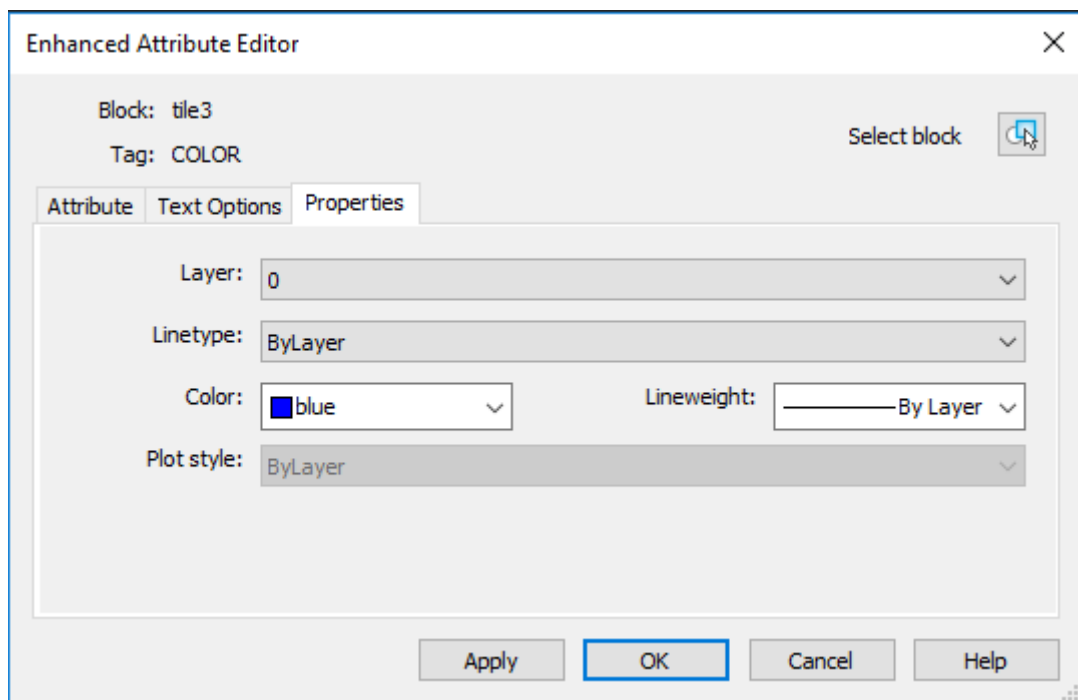

When named plot styles are used in the drawing, the style of the attribute is selected from the list of the **Plot style** option. If the current drawing uses color-dependent plot styles, the Plot style list is not available.

## Block Attribute Manager

If a block contains a large number of attributes, it is convenient to use **Block Attribute Manager** for quick editing of attributes directly in the drawing.

The Manager changes the attributes to define a block (not a reference). To update existing references, use block reference attribute synchronization.

You can edit attribute descriptions in blocks, remove attributes from blocks, and change the order in which attribute values are prompted when inserting a block.



Ribbon: **Home, Insert – Block** >  **Block Attribute Manager**



Menu: **Edit – Object > Attributes** >  **Block Attribute Manager**



Command line: **BATTMAN**

The Manager will be launched only in case if at least one block with attributes is available in the drawing.

The Manager displays the following information:

**Block:** - name of the block whose attributes are being edited;



The **Select block** button allows you to select on the screen the block for editing attributes. The dialog box temporary closes.

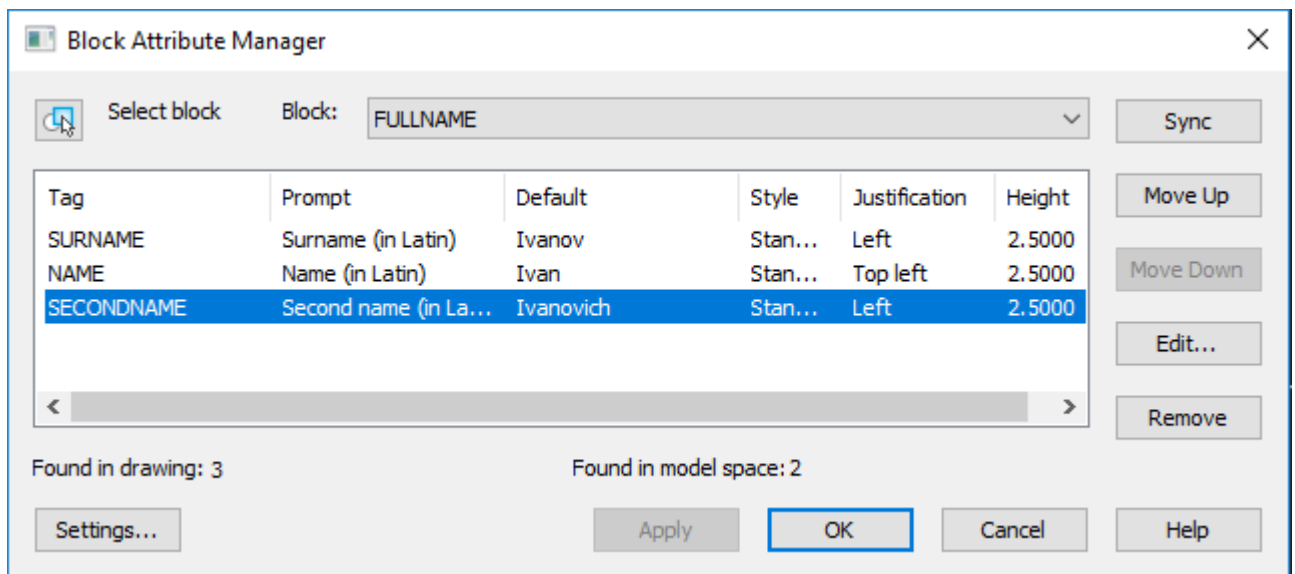

The **Apply** button is used to review the changes made without closing the **Enhanced Attribute Editor** dialog box

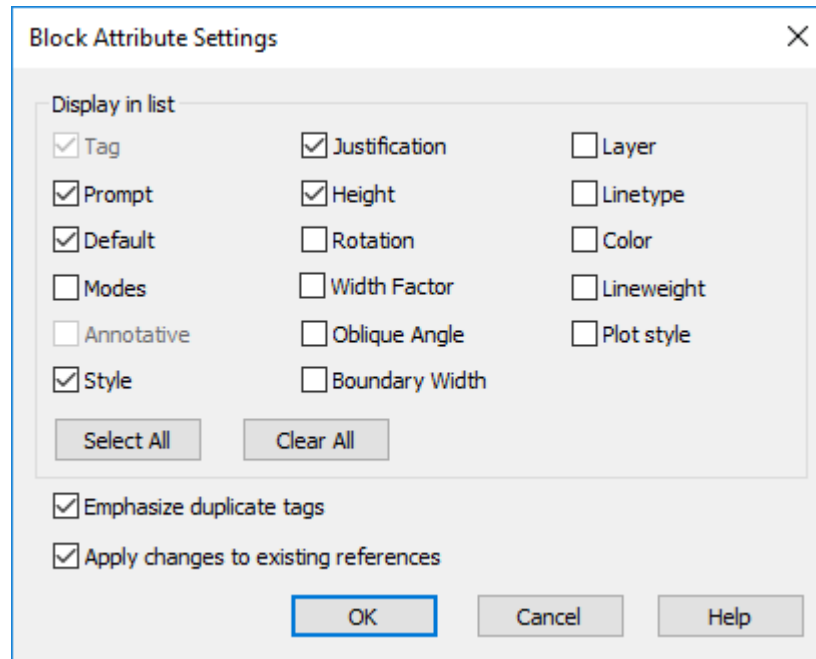

### *Attribute tab*

The tab contains the list of all attributes of the selected block and displays the following parameters for each attribute: **Tag**, **Prompt** and **Value**.

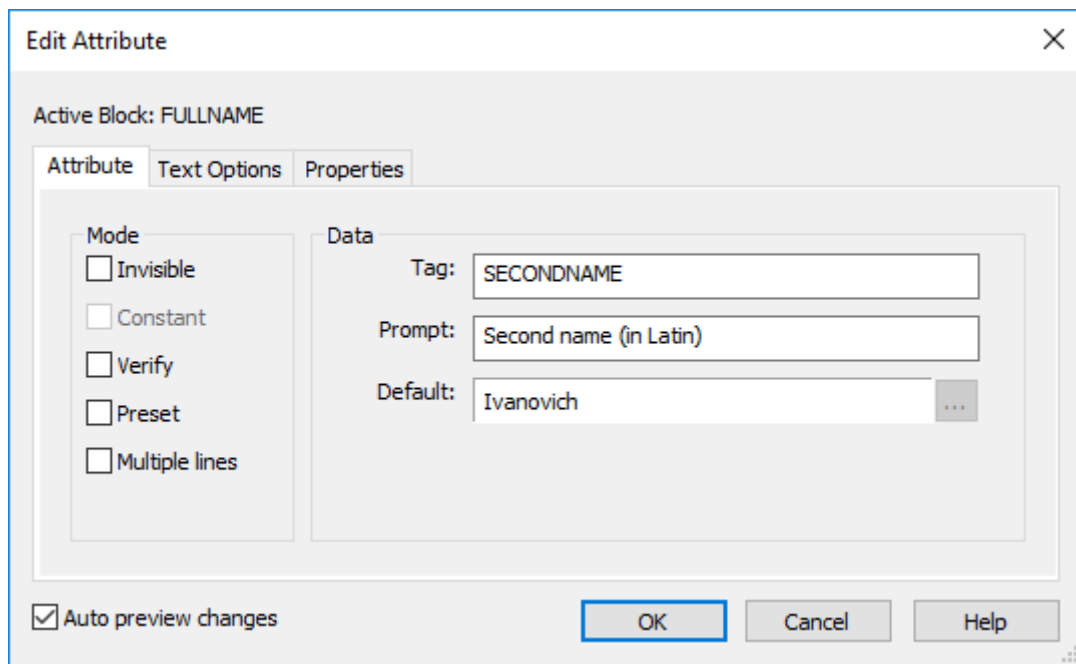

### *Text options tab*

The tab sets the options for display of the attribute text in the drawing.

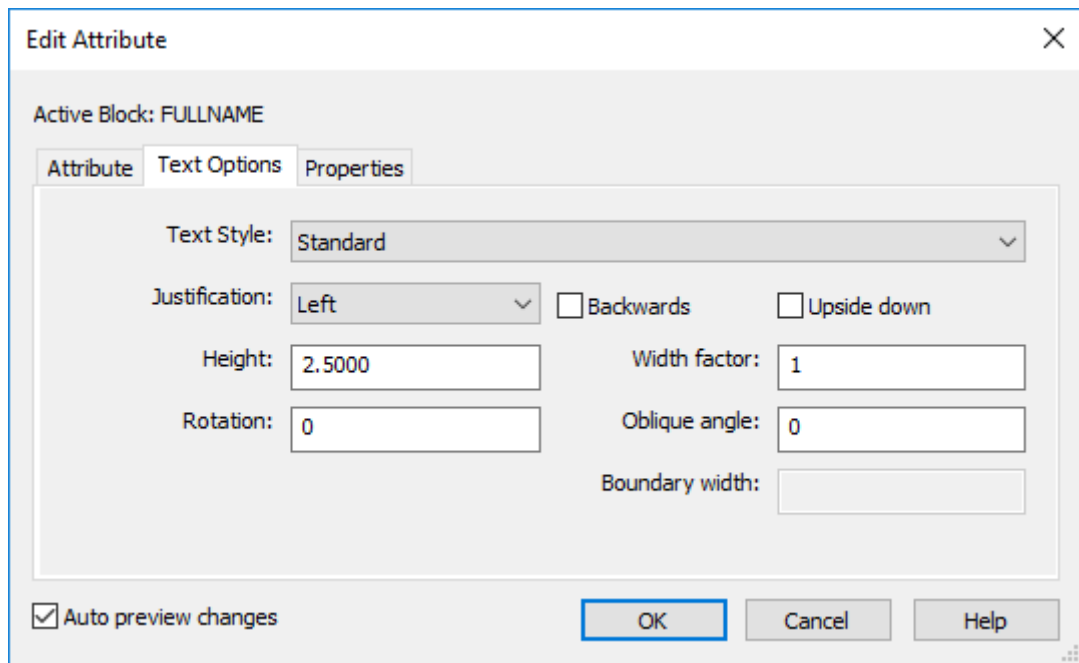

### Options:

<b>Text style</b>	Drop-down list to select the text style.
<b>Justification</b>	Drop-down list to select the type how the attribute text is justified.
<b>Height</b>	Field to enter the text height.
<b>Rotation</b>	Field to enter the rotation angle of the text.
<b>Backwards</b>	Turns on/off the mode of displaying the attribute text from right to left. The option is not available for multiple-line attributes.
<b>Upside down</b>	Turns on/off the mode of displaying the attribute text upside down. The option is not available for multiple-line attributes.
<b>Width factor</b>	Specifies the degree of condensing/expanding the attribute text. Setting the value less than 1 condenses the text. Setting the value greater than 1 expands it.
<b>Oblique angle</b>	Angle of the text slant. Is measured relative to the vertical axis. The option is not available for multiple-line attributes.
<b>Boundary width</b>	Specifies the maximum value of lines length for a multiple-line attribute; when it is exceeded, the text is automatically wrapped to the next line. A value of 0 means there is no restriction on the length of a line. The option is not available for single-line attributes.

### Properties tab

The tab defines the **Layer** that the attribute is on, specifies the **Lineweight** and **Linetype**, as well as **Color** for the attribute text.

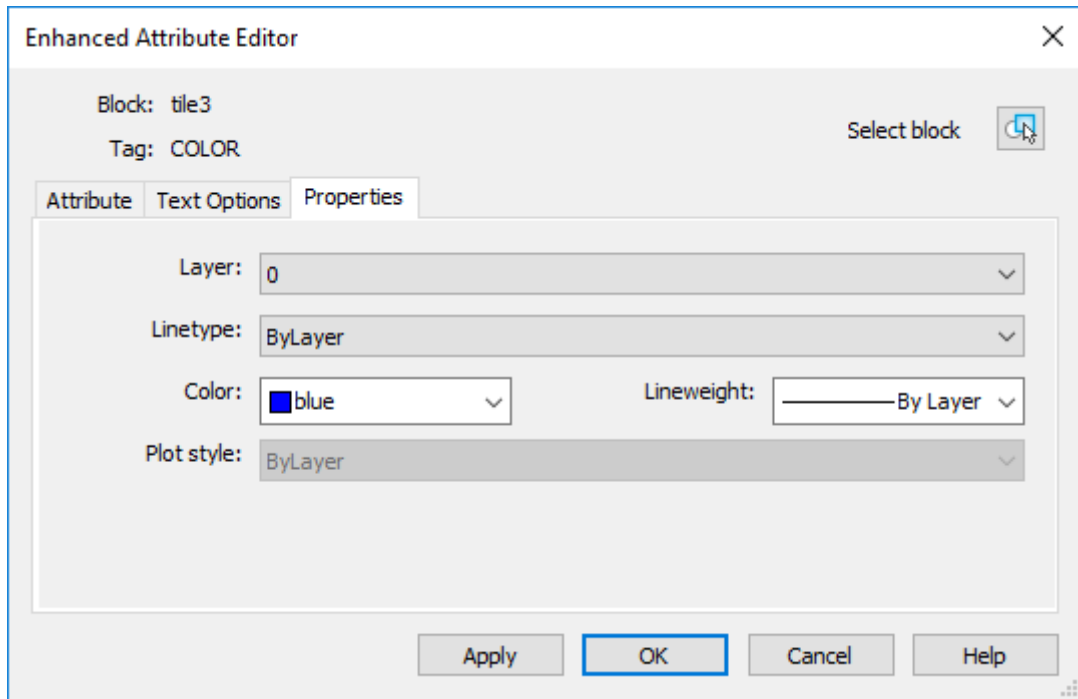

When named plot styles are used in the drawing, the style of the attribute is selected from the list of the **Plot style** option. If the current drawing uses color-dependent plot styles, the Plot style list is not available.

## In-Place Attribute Editing

Allows you to edit block attribute values directly in the drawing.



Ribbon: **Home – Block** >  **Edit in place**



Menu: **Modify – Object** > **Attributes** >  **Edit in place**



Command line: **ATTIPEDIT**



Hot keys: **CTRL** + left double click on the attribute.

1. Start the command;
2. Select the attribute;
3. Enter a new attribute value.

## Editing Block Attribute Definitions

Modes and options of attribute definitions can be modified of the *mode of editing a block definition*:

1. Open the **Block Editor** (menu **Tools – Block editor**), select the block, click **OK**.
2. In the mode of editing a block definition, select the attribute.
3. Set the required attribute modes and options on the **Properties** panel.

Left double-click on the attribute opens the **Attribute Redefinition** dialog box, where it is possible to modify **Tag**, **Prompt** and **By default** attribute value.



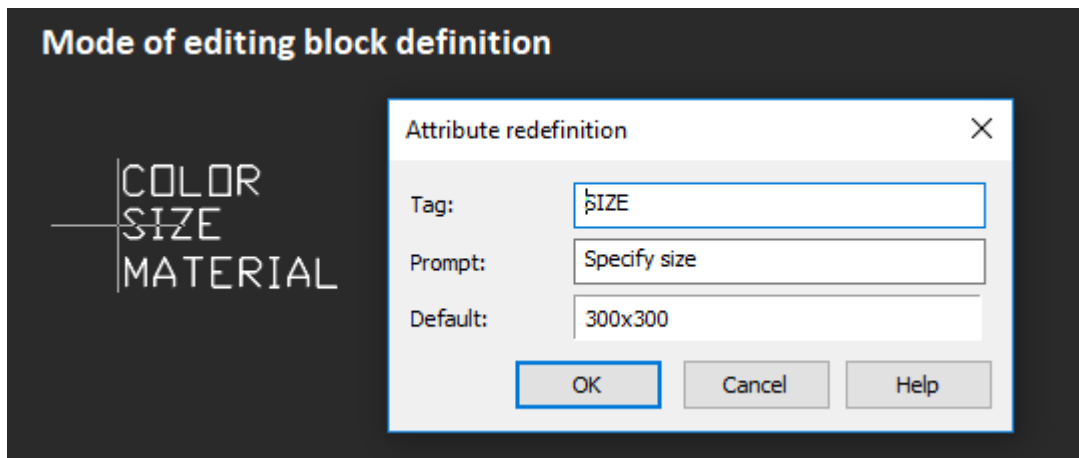

## Synchronizing Attributes of Block References



Ribbon: **Home – Block** >  **Synchronize Attributes**



Panel: **Edit 2** – 



Command line: **ATTSYNC**

Updates block references taking into account new and modified attributes from the specified block definition.

The command updates all instances of blocks containing attributes that were redefined with help of **BEDIT** command. The command does not change values assigned to attributes of the existing blocks.

### Command query

Define option [?/Name/Select]

### Command options:

- ? Opens the list of all block definitions in the drawing.
- Name Enters names of blocks that should be updated with the specified current attributes.
- Select Selects on the screen the blocks whose attributes should be updated.

**ATTENTION!** The **ATTSYNC** command deletes any change of format or property made in the block attribute management commands **ATTEDIT** or **EATTEDIT**. It also deletes any additional data associated with the block and can influence on dynamic blocks or blocks created in third party applications.

## Controlling Display of All Block Attributes in a Document

Commands that control the settings for visibility redefinition of all block attributes in the drawing are located in the menu **View – Display > Attributes**. Changing visibility state of attributes requires regeneration of the drawing.

The current visibility state of all attributes in a drawing is stored in the **ATTMODE** system variable. The *0* value of system variable corresponds to turned off state of attributes visibility, *1* – normal state, *2* – turned on.



Ribbon: **Home, Insert – Block** >  **Attributes: Normal**



Menu: **View – Display > Attributes > Normal**

Turns on the visibility state of all attributes defined during their creation: visible attributes are displayed on the drawing, invisible are not.



Ribbon: **Home, Insert – Block** >  **Attributes: On**



Menu: **View – Display** > **Attributes** > **On**

Turns on the visibility state of all attributes, including those that were defined as invisible during creation.



Ribbon: **Home, Insert – Block** >  **Attributes: Off**



Menu: **View – Display** > **Attributes** > **Off**

Turns off the visibility of all attributes, including those that were defined as visible during creation.

## Extracting Data from Attributes



Ribbon: **Insert – Block** >  **Attribute Extraction**



Command line: **ATTEXT**



Non-dialog version: **-ATTEXT**

The command allows you to extract data from attributes and save them in a text file, which then can be transferred into any database management system. This allows you to create easily different reports and specifications by using directly the data from a drawing. For example, if in the facilities layout plan each unit of equipment represents a block with attributive information, which specifies name, manufacturer, price, etc., it is easy to create reports with the number of equipment, total price of equipment and others.

After started, the command opens the **Attribute extraction** dialog box

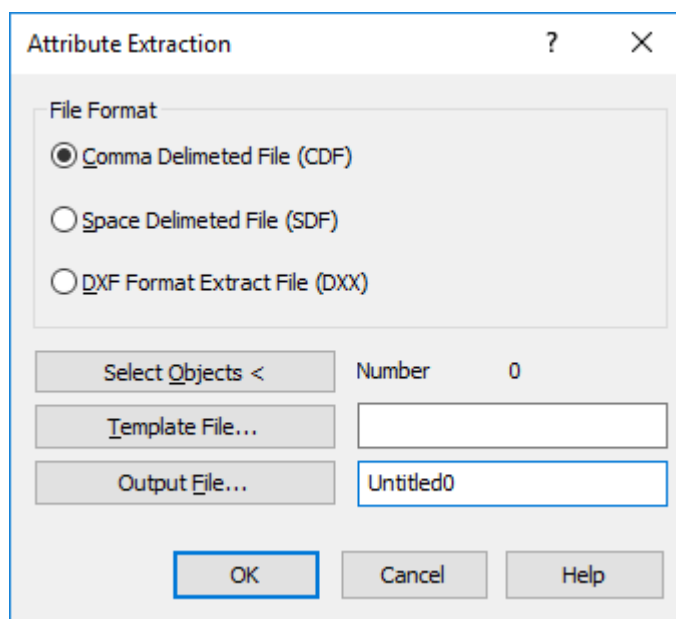

## Options:

### File format

#### Comma-delimited format (CDF)

Turns on the mode for saving the data extracted from attributes into a \*.cdf file (Comma Delimited Format), containing one record for each block reference in a drawing. Record fields are separated by commas. Character fields are taken in single quotation marks (apostrophes).

When extracting data from attributes in \*.cdf format, it is necessary to specify the template file. The template file should contain at least one attribute name.

#### Space-delimited format (SDF)

Turns on the mode for saving the data extracted from attributes into a \*.sdf file, containing one record for each block reference. Fields of each record have a fixed length, therefore, they require neither record separators, nor character-string delimiters.

When extracting data from attributes in \*.sdf format, it is necessary to specify the template file. The template file should contain at least one attribute name.

#### Drawing interchange format DXF (DXX)

Turns on the mode for saving the data extracted from attributes into a \*.dxx file (subset of a standard drawing interchange file format \*.dxf), containing only descriptions of block references and attribute values. The file extension .dxx distinguishes an extraction file from normal \*.dxf files.

When extracting data from attributes in \*.dxx format, it is not required to specify the template file.

### Buttons

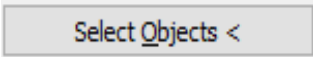

The button for temporary closure of the dialog box to select blocks with attributes in the drawing.

After clicking **ENTER** to finish the selection of objects, the **Attribute extraction** dialog box is displayed again.

#### Number:

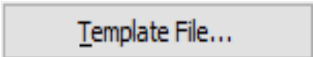

Displays the number of selected objects.

The button opens a standard dialog box for selecting files to specify the name and location of a template file in the format of which the data extracted from attributes will be recorded.

By default template files have .txt extension.

The path and name of the selected file are entered or displayed in the field right to the button.

When the **Drawing interchange format DXF (DXX)** option is specified, the **Template file** button and text field to the right are enabled.

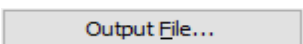

The button opens a standard dialog box for selecting files to specify the name and location of the file into which the data extracted from attributes will be recorded.

By default .txt. extension of the file name is added to CDF and SDF files, and .dxx extension is added to DXF files.

The path and name of the selected file are entered or displayed in the field right to the button.

## Converting block attributes to text



Ribbon: **Home – Block** >  **Explode Attributes to Text**



Menu: **Modify – Advanced tools >**  **Explode attributes to text**



Command line: **BURST**

The command allows you to extract text information from block attributes while breaking them.

Pay attention that in contrast to **Explode** command at using which the attribute values are deleted, and only names remain, the **BURST** command converts block attribute values to single-line and multiple-line texts.

Value of the field inserted during creation of a block attribute is also converted to text.

Hidden block attributes are not converted to text.

1. Select the block with attributes.
2. Start the **Convert block attributes to text** command

## Exploding a Block Reference

While breaking a reference, a block is split into component objects.

To break the block reference, it is necessary to enter the **Explode** command or click  button on the **Edit** panel. If exploding was prohibited during creation of a block definition, the references of such block will not be exploded.

## Reset Block



Block insert context menu:  **Reset block**



Command line: **RESETBLOCK**

Returns the parameters of the selected dynamic block inserts to their original state, resetting the entire history of their modifications.

The command is designed to restore dynamic block inserts to their original state in order to eliminate distortions that appeared during the block modification.

After inserting a dynamic block definition, any user intervention “detaches” it from the parent block, and generates a temporary block with the changed geometry, to which the definition is attached. At the same time, all interventions are written into the history, which is stored in the block definition.

When working in the **Block Editor**, it changes the parent block, after which the following actions are performed for each insert: a temporary block is deleted, a copy of the new parent block is generated, to which the entire change history of this particular insert is applied, step by step. The main problems can occur just at the last stage, since there are many types of interventions on the block insert available to the user - from changing properties to setting values through dynamic input. The **Reset Block** command resets everything and returns the selected dynamic blocks to their original state of the initial insert.

## Managing Blocks in the Current Drawing



Ribbon: **Insert – Block >**  **Blocks**



Menu: **Format –**  **Blocks...**



Command line: **BLOCKS, BLOCKSCMD**

The **Blocks** dialog box includes information on all block definitions contained in the document and on the number of their references:

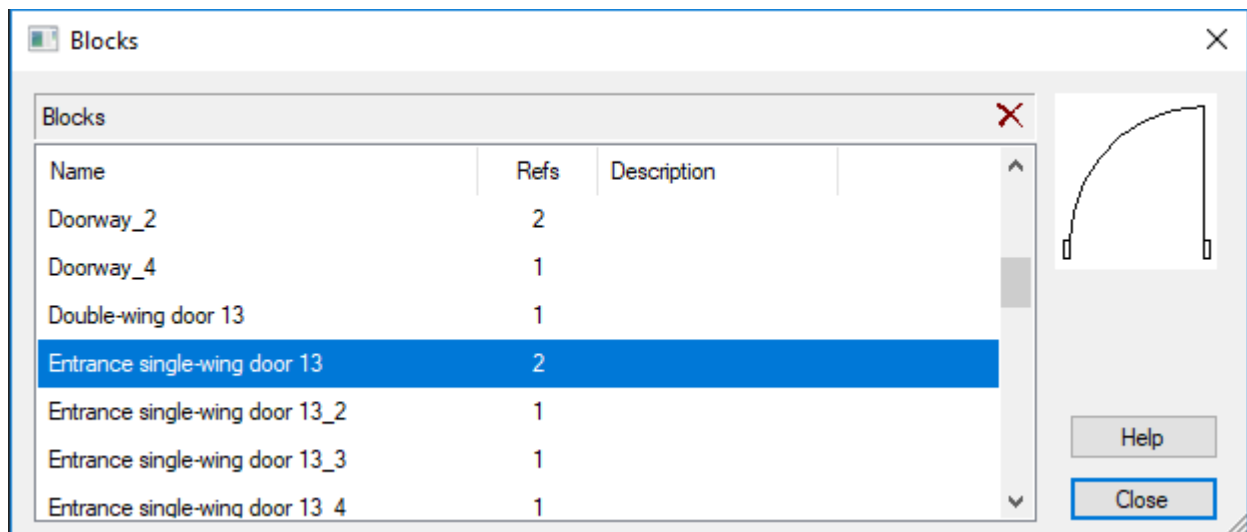

*Columns:*

<b>Name</b>	List of block definitions contained in the document.
<b>Refs</b>	Displays information on the number of block references in the current document.
<b>Description</b>	Displays information entered during the block creation in the <b>Description</b> section of the <b>Block definition</b> dialog box.

Left double-click on the column names separator automatically modifies the columns width.

**To rename a block:**

1. Left double-click on the block name.
2. Enter a new block name from the keyboard.

**To delete the block definition:**

1. Select in the list the block to delete.
2. Click  button or select the **Delete** command in the context menu opened by the right click
3. Confirm the deletion by clicking **Yes** button.
4. Click the **Close** button to exit the dialog.

**NOTE:** The block definition is deleted in the **Blocks** dialog box, while block reference is deleted by selecting it in the drawing area, with further opening of the **Delete** command (or **DEL** key).

**NOTE:** Some block definitions are systemic. They cannot be deleted.

## Saving a Block in a Separate File



Ribbon: **Insert – Block Definition >**  **Write Block**



Command line: **WBLOK, ACADWBLOCKDIALOG, W**

The command allows you to save in a separate file:

- a whole drawing with all changes made;
- a block contained in a drawing;
- separate fragments of a drawing.

Starting the **WBLOCK** command opens the **Write block** dialog box:

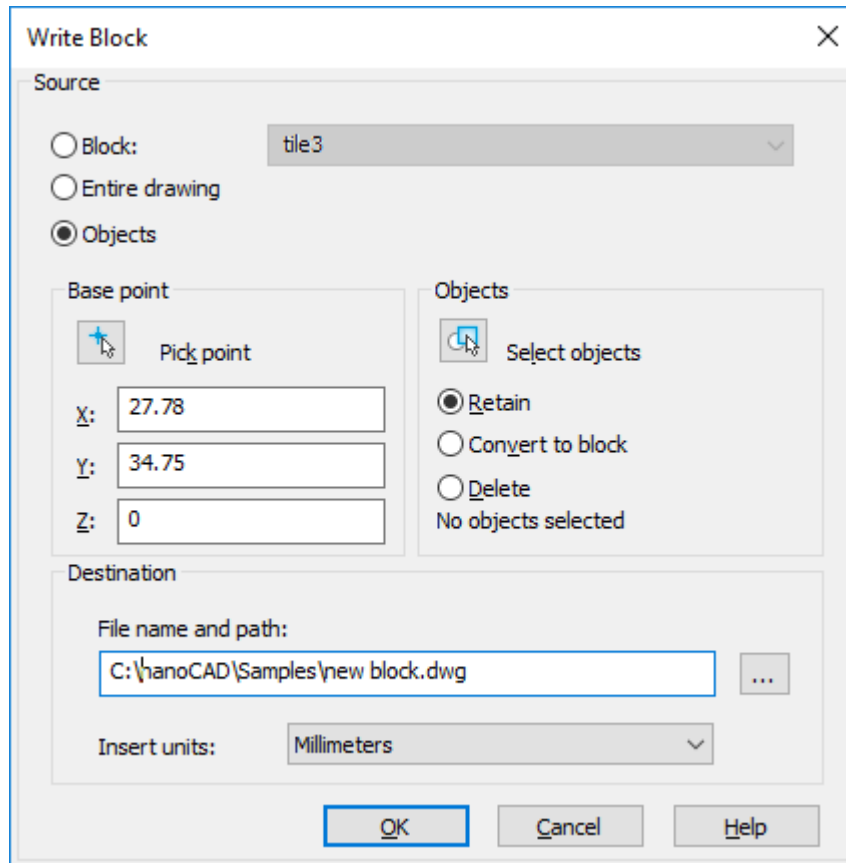

### Options:

#### Source

##### **Block:**

Turns on the mode for selecting from the drop-down list the block to be saved contained in the drawing.

Pay attention: If there is not a single block in the drawing, the option is disabled.

##### **Entire drawing**

Turns on the mode for saving the entire drawing in a separate file.

##### **Objects**

Turns on the mode for saving objects selected in the current drawing in a separate file.

#### Base point



##### **Pick point**

Button that temporarily closes the dialog box so that you can specify the base point on the screen by the mouse cursor.

##### **X: Y: Z:**

Enters base point coordinates.

#### Objects



##### **Select objects**

Button that temporarily closes the dialog box so that you can select objects on the screen by the mouse cursor.

##### **Retain**

Turns on the mode for retaining the selected objects in the drawing after they are saved in a separate file.

- Convert to block** Turns on the mode for creating a block reference in place of the selected objects after they are saved in a separate file.
- Delete from drawing** Turns on the mode for deleting the selected objects from the drawing after they are saved in a separate file.
- Objects selected:** Displays the information on the number of objects selected for saving.

### Destination

- File name and path:** Button  opens the **Save Document** dialog box to specify the path, name and format of file to be saved.
- Insert units** Drop-down list for selecting measurement units for the file being saved.

## Proxy Objects

DWG-files can contain foreign objects created in other applications. Definitions of such objects are understandable for nanoCAD system only in case of downloading the files of parent applications *adapters* (usually files with .nrx extension). All unidentified objects are called *proxy objects* (they can both have a graphic representation or not have it). Such objects cannot be edited, sometimes they cannot be broken by **EXPLODE** command, they have no grips. Graphics of a proxy object can differ from the real object's graphics displayed when the adapter is downloaded. Values of system variables PROXYGRAPHICS and PROXYSHOW make an additional impact on the procedure for displaying proxy objects.

The **Samples** folder includes the file **nCAD and proxy-objects.dwg**, which contains objects created by other applications (AutoCAD Architecture and nanoCAD SPDS). If no adapters are downloaded, all these objects are classified by nanoCAD system as proxy objects.

If you download adapters with necessary definition in nanoCAD, then proxy objects are converted into primitives and non-graphic objects you can perform actions with.

There are possible cases, when proxy objects (all or some) interfere with a normal work with a drawing. In such case they can be either deleted or broken into known primitives (segments, texts, etc.).

## Removing Proxy Objects



Ribbon: **Draw – Explode/erase** >  **Erase proxy**



Menu: **Modify – Advanced tools** >  **Removing proxy**



Command line: **RMPROXY**

The command is used to remove proxy objects. Pre-selection of objects is acceptable. If there are no selected objects, the command makes a query:

Select objects or [?/Drawing/Nongraphicalproxies]:

In response to the query it is possible to select objects or specify an option.

Option ? makes a query to change the method for selecting objects (similar to **SELECT** command):

Select an option or  
[Window/Last/Crossing/BOX/ALL/Fence/WPolygon/CPolygon/Group/Add/Remove/Current/Auto]:

The Drawing option is used to select all proxy objects in a drawing, including objects on other drawing tabs

The Nongraphicalproxies option is intended to delete only *proxy-objects without graphics*, objects without graphics, which cannot be selected in another way.

After the user specifies the required option, the system will perform removal and report on the number of detected and deleted proxy objects, for example, when selecting Nongraphicalproxies option:

1526 proxy objects found, including 348 graphical proxy objects.

1526 proxy objects removed, including 348 graphical proxy objects.

Objects that are not proxy objects may get in the set of objects selected for **RMPROXY** command. No actions will be performed with such objects.

## Exploding Proxy Objects



Ribbon: **Draw – Explode/erase** >  **Explode proxy**



Menu: **Modify – Advanced tools** >  **Exploding proxies**



Command line: **XPROXY**

The command is intended for breaking proxy objects having graphical representation into ordinary objects. Pre-selection of objects is acceptable. If there are no selected objects, the command makes a query:

Select objects or [?/Drawing]:

In response to the query it is possible to select objects or specify an option. The Drawing option is intended to select all proxy objects with graphics in a drawing, including objects on other drawing tabs, which cannot be selected in another way. Upon specifying this option, the system will perform the explode and report on the results, for example:

Proxies exploded: 348

New objects created: 5629

Option ? makes a query to change the method for selecting objects, similar to **SELECT** command query.

If objects that are not proxy objects get in the set of objects selected for **XPROXY** command, they will be ignored.

## Insert External Reference



Ribbon: **Insert – Reference** >  **DWG Reference**



Menu: **Insert** –  **DWG Reference**



Toolbar: **Draw** – 



Command line: **ATTACH, XA, XATTACH**

External references allow you to add information from other drawings to the current document. It is possible to insert several external references into one document. Conversely, the same document can be used as an external reference in several other documents. External references can contain inserted external references. When you add an external reference, all external references inserted in it will also be displayed in the current drawing.



External references can only link external documents to the current document. The objects placed in the drawing file with external references are displayed in the current drawing with other objects in this drawing, but they are not added into the drawing. The external reference is a kind of label that indicates the path to an external drawing. When you add the external reference, its objects are not copied into the current drawing or loaded from the external reference file every time you open basic drawing or restart the external reference. Any changes made to the external reference will be also displayed when you open the basic document or restart an external reference.

When you insert an external reference into the drawing, the file size of the current drawing is increased slightly.

Since the external references are always kept in separate files, then the exchange of drawings should convey not only the basic drawings, but all drawings which are referred to.

You can specify different types of external reference: attachment into the drawing and overlay on the drawing. When you insert an external reference using an attachment type, then all external references inserted into the drawing are added to it. If you choose an overlay type when you insert an external reference, then external references inserted into it are ignored. Overlay external references are used when the information provided by an external reference in the current drawing is not needed for later use of this drawing as an external reference.

There are three ways to save path information with an attached reference:

- **Full (absolute) path** is a fully specified folders hierarchy that locates the file reference. This is the most precise but the least flexible option. The full path includes a letter of a mapped local hard drive, a website URL, or a mapped disk letter on a network server.
- **Relative path** is a partially specified folders hierarchy that is defined relative to the current drawing (the folder in which it is stored). If you choose this type, it is necessary to save the current drawing. For the enclosed reference the relative path specifies a reference location, which can be the current open document. This is the most flexible option, and enables you to move your current drive to a different drive that uses the same folder structure. If the file that is being referenced is located on a different local hard drive or on a network server, the relative path option is not available.

Rules of making relative paths:

<b>\</b>	Root folder of hard drive, where a current drawing is stored.
<b>path</b>	A path starting from a folder where a current drawing is stored.
<b>\path</b>	A path starting from a root folder.
<b>.\path</b>	A path starting from a folder where a current drawing is stored.
<b>..\path</b>	A path starting from a folder which is one level up from a folder where a current drawing is stored.
<b>..\..\path</b>	A path starting from a folder which is two levels up from a folder where a current drawing is stored.

When a drawing containing external references is saved or replaced to other hard drive, computer or network server it is required to change all relative paths according to a new location of drawing or change location of external references files.

- **No path** – not specify a path to an external reference. Specifying the **No path** option is useful when moving a set of drawings to a different folder hierarchy or to an unknown folder hierarchy. If a path for an external reference is not specified, the program searches for the external references in a current folder of a main drawing.

To insert an external reference into the drawing, specify the path and file name in the opened External Reference dialog box: To insert an external reference, the **External Reference** dialog box opens, which is a standard Windows file open dialog in which you should specify the path and file name to insert as an external reference. To specify several files at once for simultaneous insertion, select them with the CTRL or SHIFT.

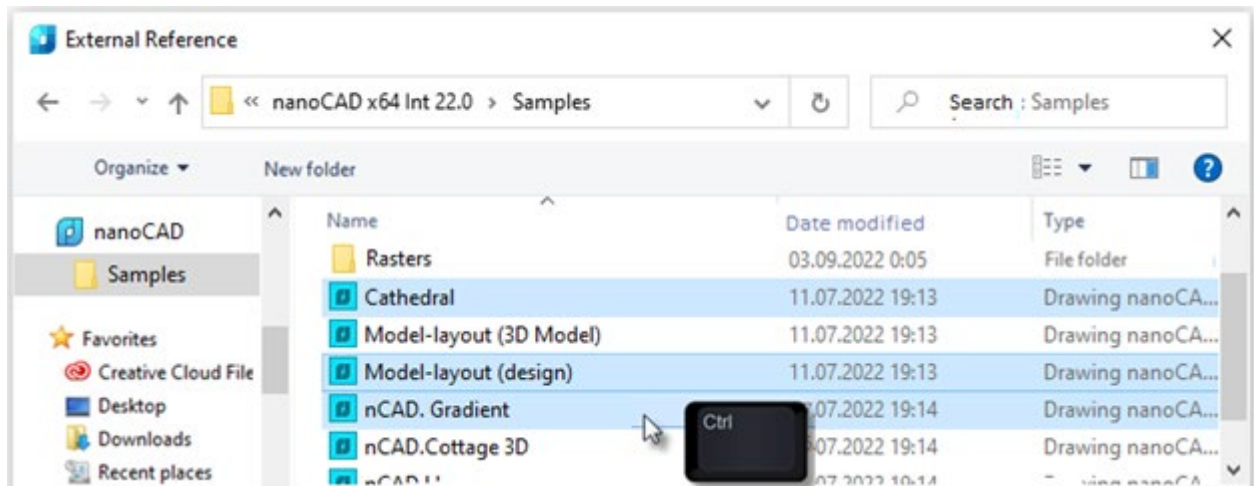

Select the necessary external reference and click **Open**. The **External Reference** dialog box will open.

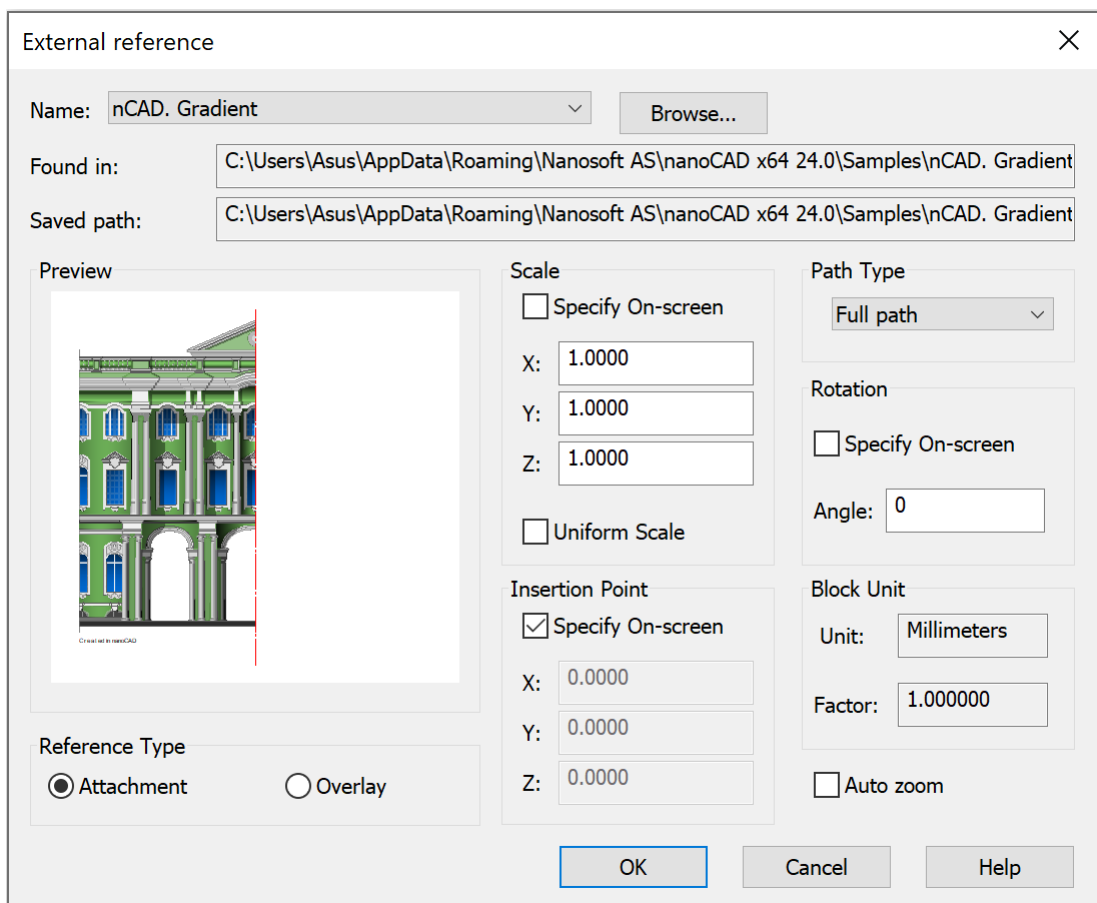

**NOTE:** In case you insert multiple files at once, many insertion parameters will not be available.

### Parameters:

**Name:** The list of the names of the external references inserted into the drawing.

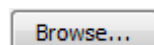
 Opens the Open dialog box to choose files for the insertion of new references.

**Found in:** Displays the file path where the external reference is to be found.

**Saved path:** Displays the saved path of access to the external reference.

*Reference Type*

**Attachment** When you attach a drawing file as an external reference, you link that referenced drawing to the current drawing.

**Overlay** An overlaid external reference is not included when the drawing is itself attached or overlaid as an external reference to another drawing.

*Path Type*

Selects the saved path type to the external reference:

- Full path**
- Relative path**
- No path**

*Insertion Point*

**Specify On-screen** Selects the box to set the X,Y,Z coordinates values in the command line or specify the position on the screen. The «X» «Y» «Z» fields of this section are inaccessible.

**X: Y: Z:** Sets the X, Y, Z coordinate values in the corresponding fields of the current document.

*Scale*

**Specify On-screen** Selects the box to set the scale values in the command line or specify the position on the screen. The «X» «Y» «Z» fields of this section are inaccessible.

**X: Y: Z:** Sets the scale values in the corresponding fields of the current document.

**Uniform Scale** Sets the scale factors on the Y and Z axes to the same scale factor as the X axis.

*Rotation*

**Specify On-screen** Selects the box to set the rotation angle value in the command line or specify its position on the screen. The Angle field of this section is inaccessible.

**Angle:** Sets the angle value on which it is necessary to turn the reference entry in the current document.

*Block unit*

**Unit:** Displays the specified parameter value of the insertion units for the inserted block.

**Factor:** Displays the scale factor, which is calculated based on the block insertion units parameter value and document units.

**Auto Zoom** Switches on/off the full screen mode of the inserted reference.

The presence of xrefs in a drawing is shown by an indicator appearing in the status bar:

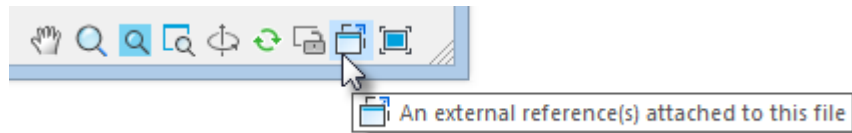

If in the course of work the xref file was changed in a third-party program, a warning will appear, and the indicator will change its appearance:

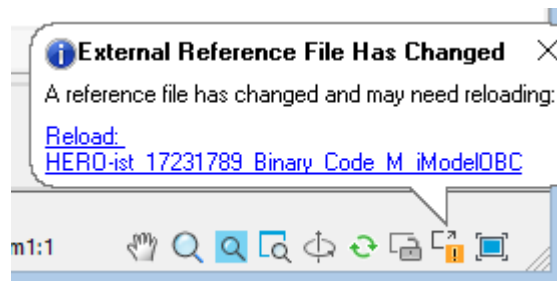

The indicator's context menu allows you to open the **External References** dialog box or **Refresh External References** of the drawing:

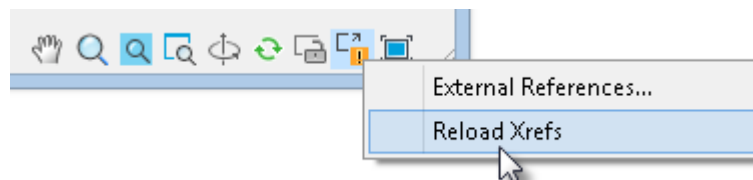

If the xref file was not found, a corresponding message appears and the status bar indicator button changes color to red:

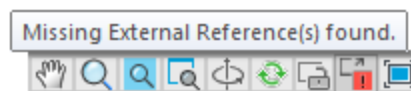

**XREFNOTIFY** variable allows you to disable notification about changes in xref files or change notifications appearance:

- 0** – disable notification about changes in external references.
- 1** – display notifications in the form of dialog boxes.
- 2** – display notifications as pop-up messages near the status bar.

The time after which external references are checked is set by the **XNOTIFYTIME** variable (in minutes).

## Edit References



Ribbon: **Insert – Reference** >  **Edit reference**



Menu: **Tools – External reference** >  **Edit reference**



Command line: **REFEDIT**

The use of external references allows you to quickly combine multiple drawings in a single document. To make work with external references more convenient, you can edit the references directly in the current drawing to which they are added.

To edit a referenced drawing from within the current drawing, you should use the working set to identify objects that belong to the external reference or block insertion rather than the current drawing. The working set includes only the objects belonging to the reference selected for editing.

You can add or remove objects from the working set. If you create a new object while editing a reference, it is almost always added to the working set automatically. Editing changes in the working set can be stored in the source file of the external reference or block insertion.

Start the **Edit reference** command. In the command line you can see:

Select reference or block insertion or [All insertions]:

Select the external reference on the drawing and in the **Select insertion** dialog box that opens, choose the objects to edit:

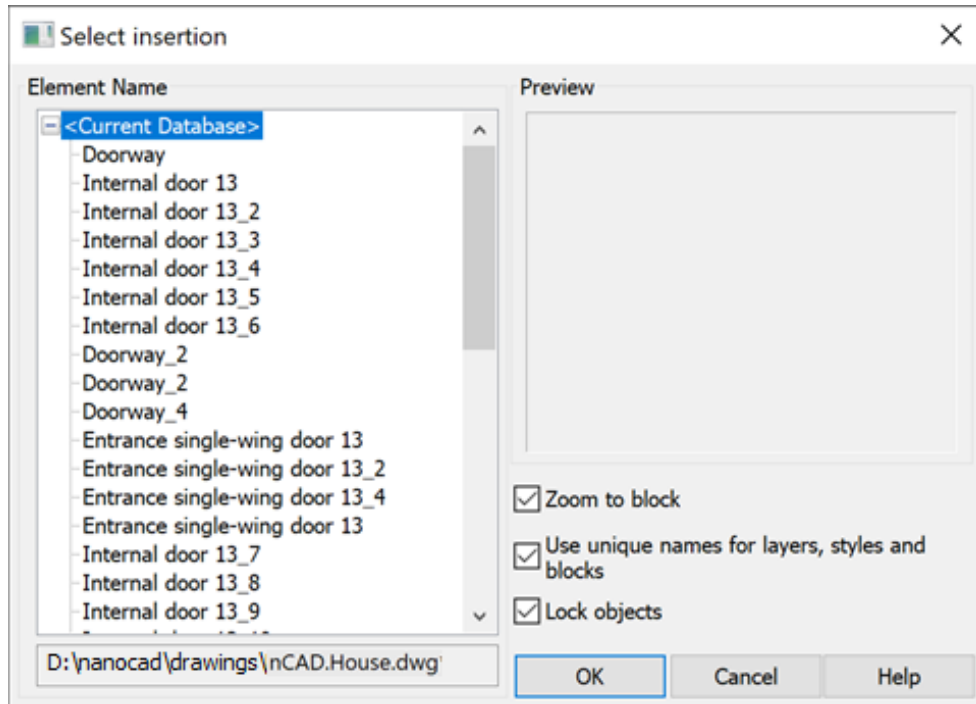

If you select the **All insertions** option in the command line, the Select insertion dialog box opens immediately and in the Element Name section all references and blocks inserted into the drawing will be displayed:

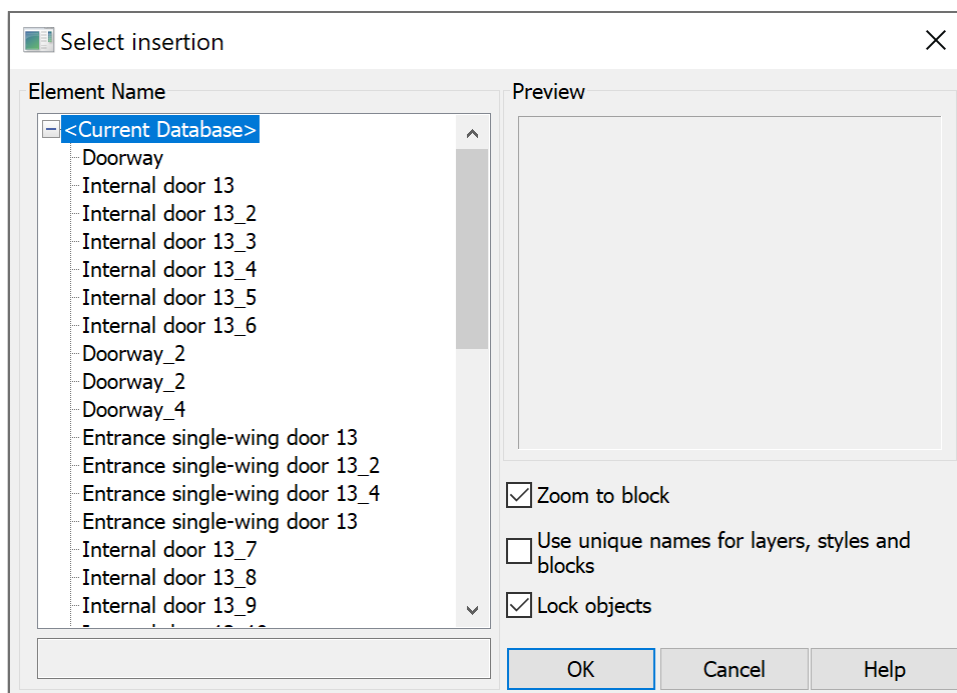

**Parameters:**

**Zoom to block** Switches on/off the mode to display the selected reference on the

screen.

**Use uncial names for layers, styles and block**

Controls whether layers and other named objects extracted from the reference are uniquely altered. If selected, named objects in external references are altered (names are prefixed with \$\$), similar to the way they are altered when you bind external references. If cleared, the names of layers and other named objects remain the same as in the reference drawing. Named objects that are not altered to make them unique assume the properties of those in the current host drawing that share the same name.

**Lock objects**

Locking objects that are not in the working set. Locked objects are not editable, which prevents objects in the source drawing from being accidentally changed in reference edit mode.

Select the objects for editing and click **OK**. The **External Reference** toolbar will appear automatically.



Use the **External Reference** toolbar to add or remove objects from a working set and also save and discard external reference editing.

*REFEDIT*, separated by a colon, is added to the document name in the tab and "Refedit mode" is shown in the top left corner of the working area. It means that work with the document occurs in the external reference editing mode.

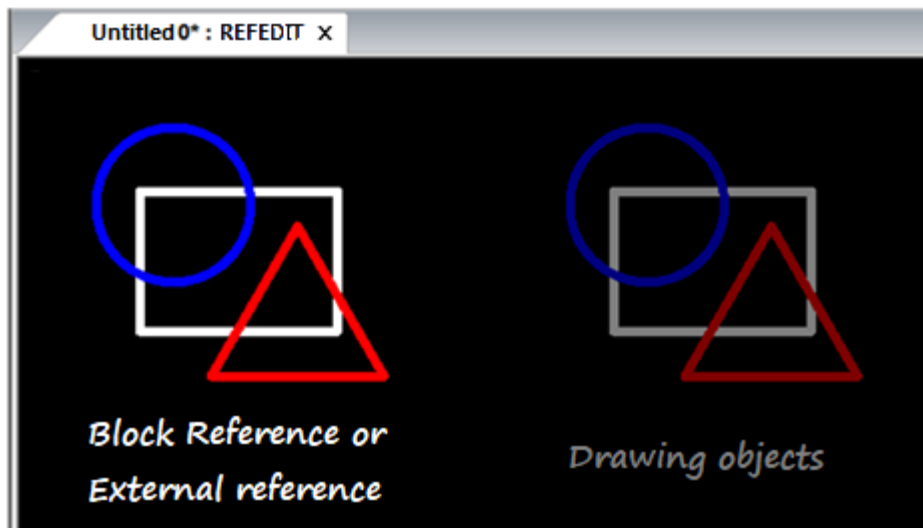

To indicate the mode of reference edit, a word **REFEDIT** is added to the document name in the tab, separated by a colon

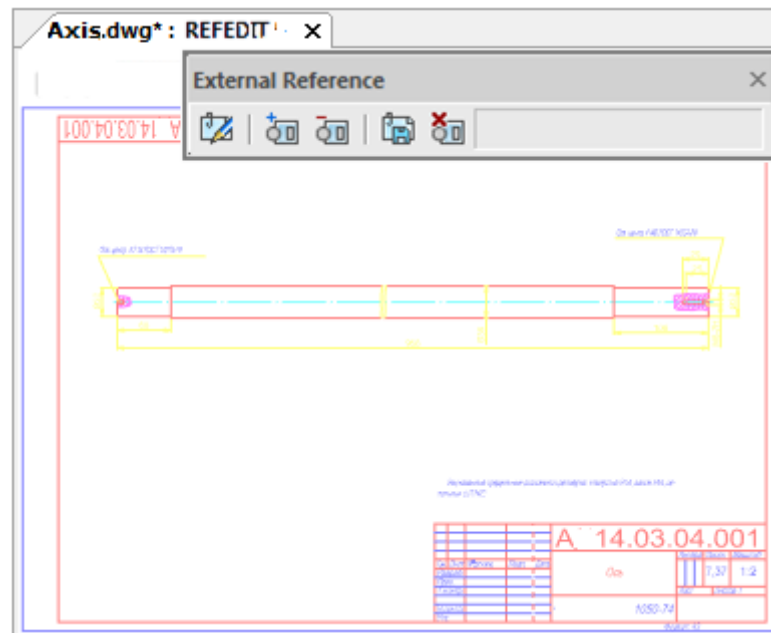

**ATTENTION!** In edit references mode you *MUST NOT (!)* close neither a document with edited reference nor nanoCAD till all changes are saved or discarded (**Save and Close** or **Discard and Close** buttons on the **Refedit** toolbar).

After saving or discarding all changes the **External Reference** toolbar closes and a document tab returns to its original view.

## Add Objects to the Working Set



Menu: **Tools – External reference** >  **Add objects to working set**



Toolbar: **External Reference** – 



Command line: **REFSET**

Use this command to transfer the objects from the current drawing to the working set.

## Remove Objects from the Working Set



Menu: **Tools – External reference** >  **Remove objects from working set**



Toolbar: **External Reference** – 



Command line: **REFSET**

Use this command to remove selected objects from the working set.

## Save External Reference Changes



Menu: **Tools – External reference** >  **Save and close**



Toolbar: **External Reference** – 



Command line: **REFCLOSES**

Use this command to save external reference changes and close the refedit toolbar. The external reference editing mode will be completed. The *REFEDIT* term, separated by a colon, that was added to the document name in the tab will disappear.

## Discard External Reference Changes

Menu: **Tools – External reference >  Discard changes**

Toolbar: **External Reference – **

Command line: **REFCLOSED**

Use this command to discard external reference changes and close the **External Reference** toolbar. The external reference editing mode will be completed. The *REFEDIT* term, separated by a colon, that was added to the document name in the tab will disappear.

## External References Manger

Ribbon: **Insert – Reference >  XREFs (External References)**

Menu: **Insert –  External References...**

Command line: **EXTERNALREFERENCES, IMAGES, XR**

The command opens the **External References** dialog box. It displays all external references contained in the document and manages these references.

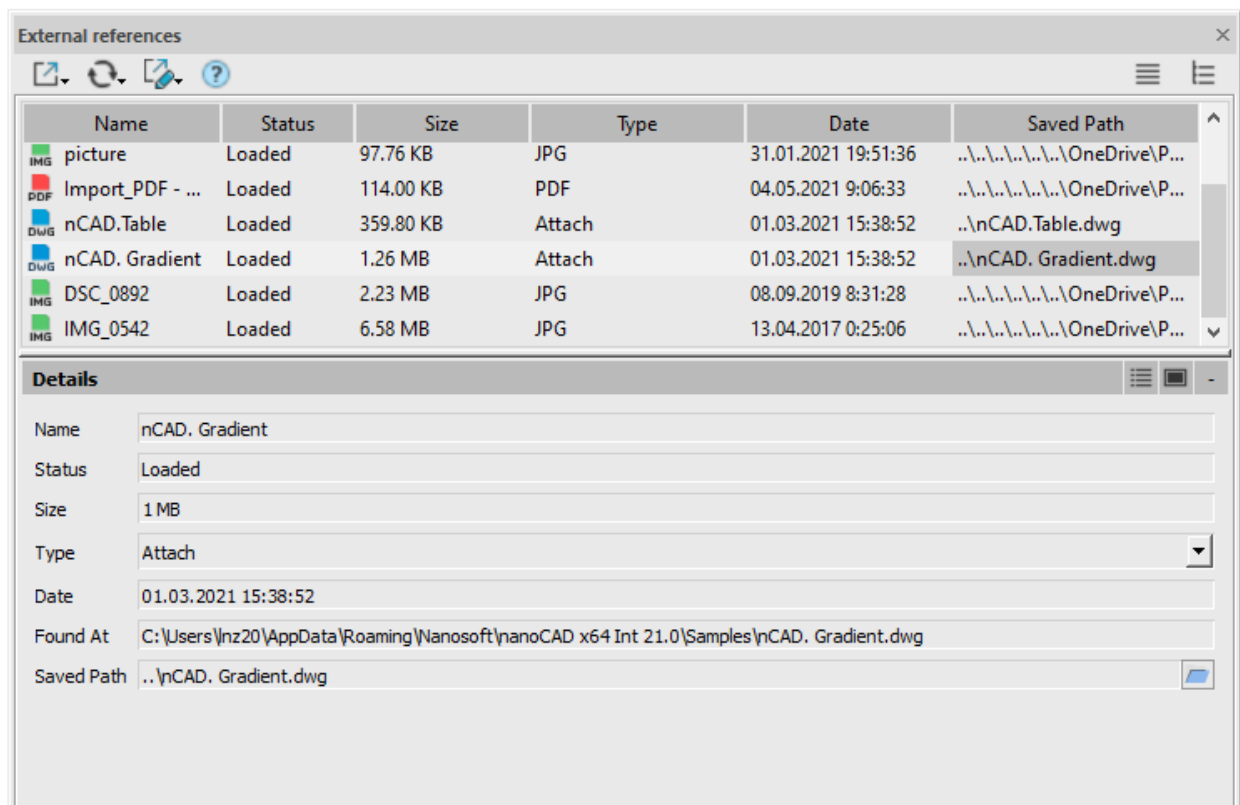

The **External references** palette allows you to perform the following operations with the referenced drawing files:

- Loading/unloading an external reference in the current drawing.



- Binding an external reference to the current drawing.
- Updating an external reference in order to display in the current drawing the latest changes made to the external reference file (without reloading the current drawing).
- Complete removing an external reference insert from the current drawing with all associated data. It is not sufficient to simply remove a reference from the drawing, since such removal would not lead, for example, to removal of layers associated with the external reference. To remove the external reference completely, use the **Remove** parameter on the **External references** palette.
- Changing the name of the reference file and its location (path).
- Changing the file type and the format settings of the file of reference to the raster image.

Xrefs selected in the dialog box are automatically selected and highlighted in the drawing. And vice versa: when xref objects are selected in the drawing, their names will be automatically selected in the **External references** dialog. The ERHIGHLIGHT system variable is responsible for synchronizing highlighting with objects in the drawing. Single and multiple selection is supported (using **CTRL** and **SHIFT**):

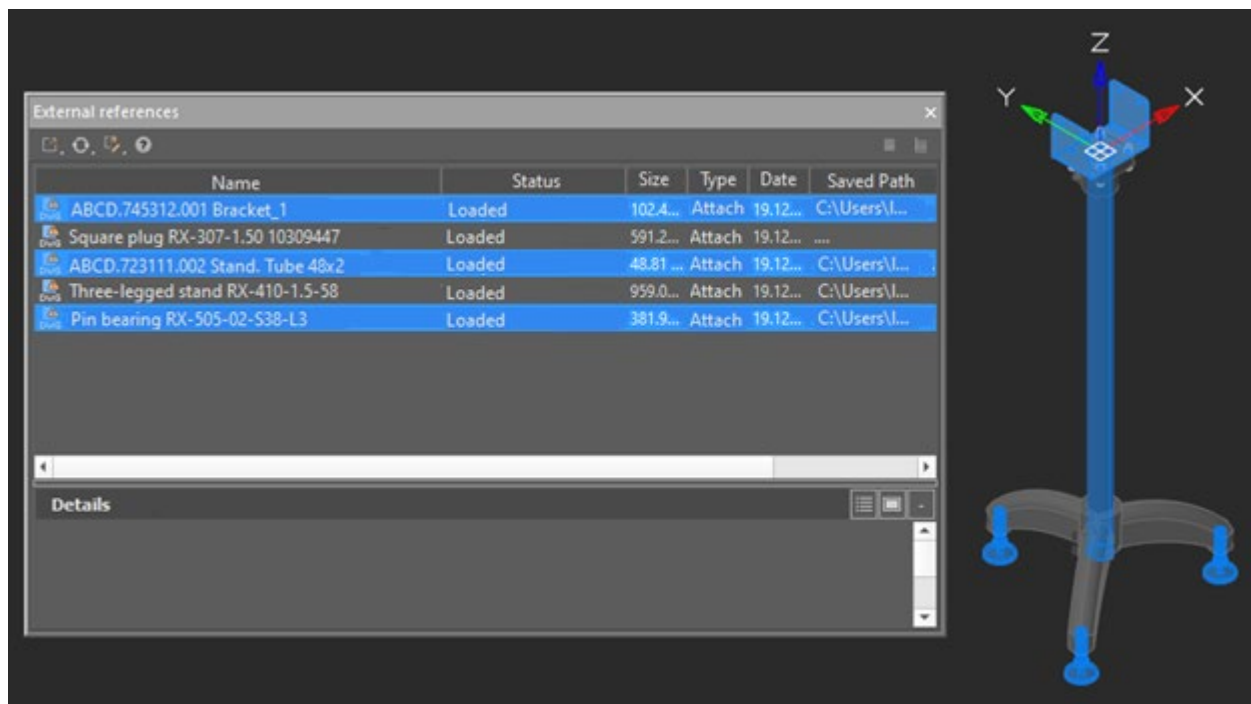

### Tools to control external references



#### Attach

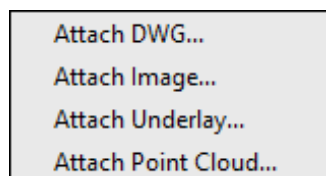

Selects xref file to attach to the current drawing.



#### Refresh

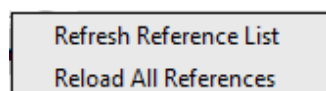

Updating information in the list.

Reloads all external references to display changes in the associated files.



### Change Path Type

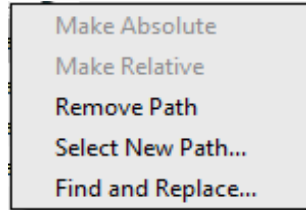

A path type can be changed to **absolute** or **relative** one.

**Remove Path** – it is expedient to remove a path, if the referenced file is located in the same folder as the current drawing.

**Select New Path** – allows you to set a new path for the missing reference.

**Find and Replace** – allows you to find those among the selected xrefs, which use the specified path and replace all references of these path to a new path. Opens the **Find and Replace Selected Paths** dialog box.



### Help

Opens help information.



### List View

Displays the palette information as a list.



### Tree View

Displays the palette information as a tree.

## Details

The section contains detailed information about the selected xref file.



### Details

Displays information about the selected file.



### Preview

Shows a thumbnail view of the selected file.



Controls visibility of the **Details** section.

## The options of the External References pane in the Show list:

<b>Name</b>	Displays the name of the external reference file
<b>Status</b>	<p>Displays the status of the external reference file:</p> <ul style="list-style-type: none"> <li>• <b>Loaded</b> – the referenced file is attached to the current drawing.</li> <li>• <b>Unloaded</b> – the referenced file is marked to be unloaded from the drawing.</li> <li>• <b>Not found</b> – the referenced file no longer exists in the valid search path.</li> <li>• <b>Unresolved</b> – the referenced file cannot be read.</li> <li>• <b>Orphaned</b> – the referenced file is attached to another file that has an <b>Unresolved</b> status.</li> </ul>
<b>Size</b>	Displays the size of the attached referenced file.
<b>Type</b>	<p>*.dwg files display the file type of the referenced file:</p> <ul style="list-style-type: none"> <li>• <b>Attachments</b></li> <li>• <b>Overlays</b></li> </ul> <p>Raster images display their file format:</p> <ul style="list-style-type: none"> <li>•</li> </ul>
<b>Date</b>	The date when the referenced file was created or last saved.
<b>Saved Path</b>	Displays the path that is saved with the drawing when the referenced file is attached.

### Context menu

The edit commands for a xref selected in the palette list are contained in the context menu and differ for different file types:

DWG	Image	PDF Underlay	Point Cloud
Reload All References	Reload All References	Reload All References	Reload All References
Select all	Select all	Select all	Select all
Open...	Open...	Open...	Unload
Attach...	Attach...	Attach...	Reload
Unload	Unload	Unload	Detach
Reload	Reload	Reload	Change Path Type ▶
Detach	Detach	Detach	Select New Path...
Bind ▶	Bind ▶	Change Path Type ▶	Find and Replace...
Xref Type ▶	Xref Type ▶	Select New Path...	
Change Path Type ▶	Change Path Type ▶	Find and Replace...	
Select New Path...	Select New Path...		
Find and Replace...	Find and Replace...		

#### Reload All References

Updates all external references of the document.

#### Select all

Selects all external references in the Manager.

#### Open

Opens the selected xref file in the source application (in which the file was created).

#### Attach

Opens the external reference dialog box with the selected file name, which allows for changing such settings as scale, insertion point and path type or select another page of an underlay file.

#### Unload

Unloads the selected reference to file from the drawing.

#### Reload

Updates the selected reference to the file.

#### Detach

Deletes the selected reference to the file.

#### Bind

The reference content is embedded in the drawing, reference to the file is deleted.

#### Xref type

#### Change xref type:

- **Attach**
- **Overlay**

#### Save as...

Changes the selected reference to a raster image. You can change xref file name, file type and file format parameters.

A World file with geocoordinates for each raster image is also created if the **Georeferencing – Use World or TAF file** box is checked in the **Options** dialog.

## External References Control (Classic Version)



Command line: **CLASSICXREF CLASSICIMAGE**

The command opens the classic version of the **External References** dialog, which is used for compatibility with previous versions of the program:

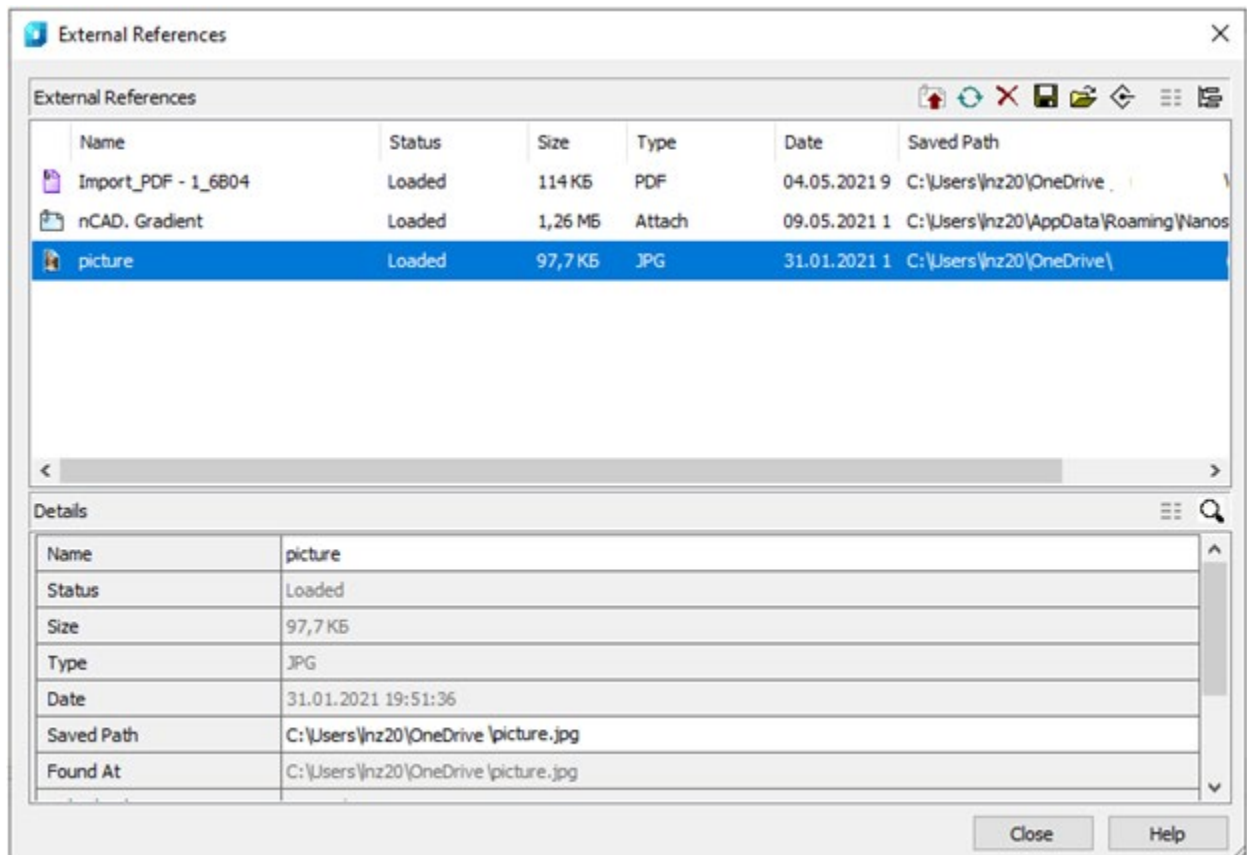

**ATTENTION!** In Edit References mode (**REFEDIT**) opening of **External references** dialog is blocked.

The dialog box displays information about the references to the inserted drawings as well as for the raster images.

The dialog box contains the tool buttons and two sections: **External References** and **Details**. Both panes are working in the double data display mode.

The **External References** pane can display information about references in a list structure (the **Show List** button) or in a tree structure (the **Show tree** button). The list view is set by default in the window.

The **Details** pane displays the properties of the references selected in the upper section in the list view (the **Show properties** button) or displays the content of the selected reference in a preview window (the **Show preview** button).

#### **Parameters of the References window in a Table mode:**









##### *Columns*

**Name** Displays the name of the external reference file

<b>Status</b>	<p>Displays the status of the external reference file:</p> <ul style="list-style-type: none"> <li>• <b>Loaded</b> – the referenced file is attached to the current drawing.</li> <li>• <b>Unloaded</b> – the referenced file is marked to be unloaded from the drawing.</li> <li>• <b>Not found</b> – the referenced file no longer exists in the valid search path.</li> <li>• <b>Unresolved</b> – the referenced file cannot be read.</li> <li>• <b>Orphaned</b> – the referenced file is attached to another file that has an <b>Unresolved</b> status.</li> </ul>
<b>Size</b>	Displays the size of the attached referenced file.
<b>Type</b>	<p>*.dwg files display the file type of the referenced file:</p> <ul style="list-style-type: none"> <li>• <b>Attachments</b></li> <li>• <b>Overlays</b></li> </ul> <p>Raster images display their file format:</p> <ul style="list-style-type: none"> <li>• <b>TIFF</b></li> <li>• <b>BMP</b></li> <li>• <b>JPG</b></li> <li>• <b>JPEG</b></li> <li>• <b>PNG</b></li> <li>• <b>PCX</b></li> </ul>
<b>Date</b>	The date when the referenced file was created or last saved.
<b>Saved Path</b>	Displays the path that is saved with the drawing when the referenced file is attached.

Left double click on separator of column names changes the width of columns automatically.

### Buttons

	<b>Unload XRef</b>	Unloads the selected file references from the drawing.
	<b>Reload XRef</b>	Reloads the selected file references to the drawing.
	<b>Detach XRef</b>	Detaches the selected file references.
	<b>Save XRef</b>	Changes the selected raster image references. It is possible to change the reference file name, file type and file format.
	<b>Open from</b>	Changes the full path to the selected reference. When you click this button the dialog window opens and you can select another path or external reference name.
	<b>Embed image</b>	Embeds raster images to the document. Such image saved in the document, not in separate file.
	<b>Show list</b>	Displays the references information in the list view.
	<b>Show tree</b>	Displays the references information in the tree view.

When the **External References** pane is set to the list view, it is possible to select several references:

- when the **SHIFT** key is pressed, then all references located between the first and last click will be selected;
- when the **CTRL** key is pressed, you can select any references from the list by clicking.

When the **External References** pane is set to the tree view, a tree structure of all external references along with their levels of nesting within the drawing will be displayed.

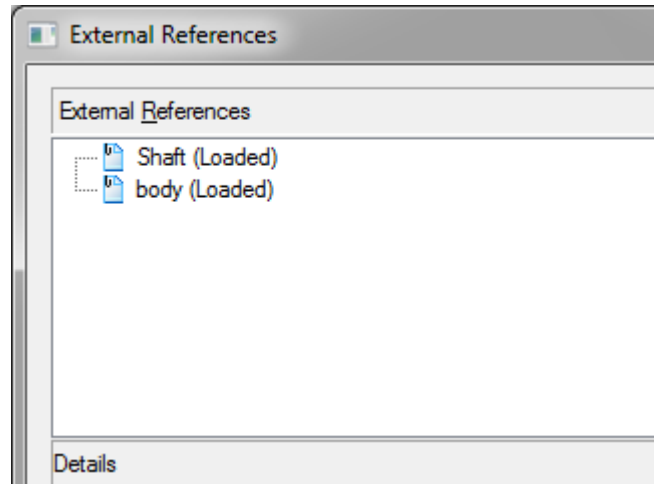

It is possible to select only one file reference in the tree view of the **External References** pane.

***The options of the Details pane in the list view:***

*Columns*

<b>Name</b>	Displays the name of the external reference file.
<b>Status</b>	<p>Displays the status of the external reference file:</p> <ul style="list-style-type: none"> <li>• <b>Loaded</b> – the referenced file is attached to the current drawing.</li> <li>• <b>Unloaded</b> – the referenced file is marked to be unloaded from the drawing.</li> <li>• <b>Not Found</b> – the referenced file no longer exists in the valid search path.</li> </ul>
<b>Size</b>	<p>Displays the size of the attached referenced file.</p> <p>The size of the attached referenced file doesn't display when the reference has the status:</p> <ul style="list-style-type: none"> <li>• <b>Unloaded</b></li> <li>• <b>Not Found</b></li> </ul>

<b>Type</b>	<p>*.dwg files display the file type of the referenced file:</p> <ul style="list-style-type: none"> <li>• <b>Attachment</b></li> <li>• <b>Overlay</b></li> </ul> <p>Raster images display their file format:</p> <ul style="list-style-type: none"> <li>• <b>TIFF</b></li> <li>• <b>BMP</b></li> <li>• <b>JPG</b></li> <li>• <b>JPEG</b></li> <li>• <b>PNG</b></li> <li>• <b>PCX</b></li> </ul>
<b>Colordepth</b>	Color information of raster.
<b>Resolution</b>	Resolution of raster (points per inch).
<b>Pixel Width</b>	Width of raster, pxl.
<b>Pixel Height</b>	Height of raster, pxl.
<b>Date</b>	<p>The date when the referenced file was created or last saved.</p> <p>The date doesn't display when referenced file has the status:</p> <ul style="list-style-type: none"> <li>• <b>Unloaded</b></li> <li>• <b>Not Found</b></li> </ul>

**Saved Path** Displays the path of the referenced file.



**NOTE!** The saved path does not necessarily indicate the present file location.

**Found at** Displays the path where the external reference file is located. This place is the actual file location.

**NOTE!** The full path and saved path may be different.

<b>Colordepth</b>	Color information of raster.
<b>Resolution</b>	Resolution of raster (points per inch).
<b>Pixel Width</b>	Width of raster, pxl.
<b>Pixel Height</b>	Height of raster, pxl.

*Buttons*

	<b>Show properties</b>	Displays the properties of the selected referenced file in the list view.
	<b>Show preview</b>	Displays contents of the selected referenced file in the preview window.

*Context menu*

The following context menu commands are available for the xref selected in the dialog box:

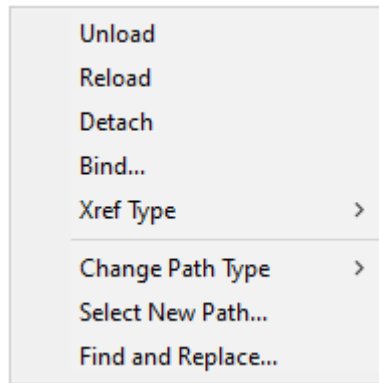

**Xref Type**

**Change xref type:**

- **Attach**
- **Overlay**

**Change Path Type**

**Changes the type of path to the xref:**

- **Make Absolute**
- **Make Relative**
- **Remove Pathe**

**Select New Path**

Searches for a new path for not found xref file. **Opens the External reference selection box to specify a new path.**

**Find and replace**

Allows you to fund among the selected xrefs the ones that use the specified path and replace all references of this path to a new path. **Opens the Find and Replace Selected Paths dialog.**

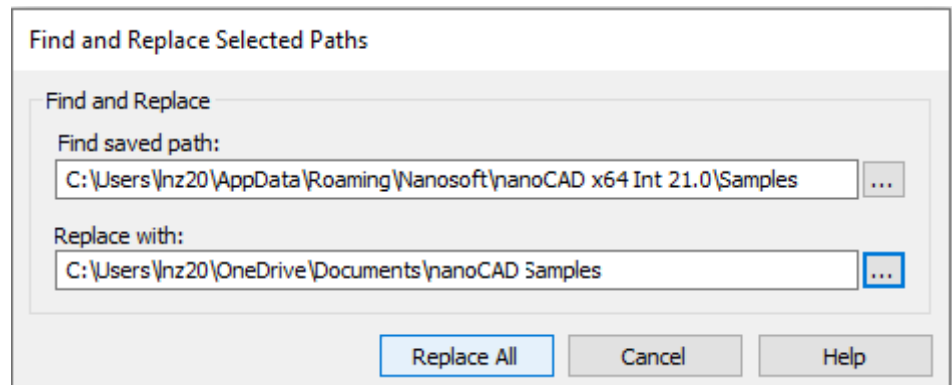

The context menu that opens when you right-click on the xref name on the **Drawing Explorer** palette, contains the following commands:

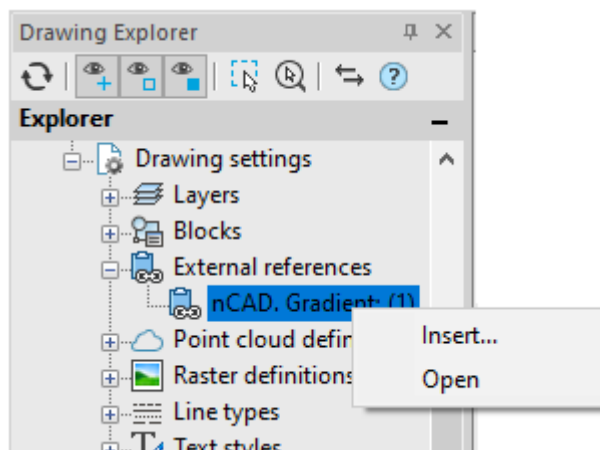

**Insert** – opens the **Insert external reference** dialog box with the name of existing external reference to re-insert or to select a file of a different xref file.



**Open** – opens the referenced drawing in a new window.

## Change of an External Reference to a Raster Image

To change reference to the image:

1. In the **External References** dialog box, select the reference to the image in the list.
2. Click the **Save**  button.
3. In the opened **Save Image File** dialog box, specify the file name and file type:

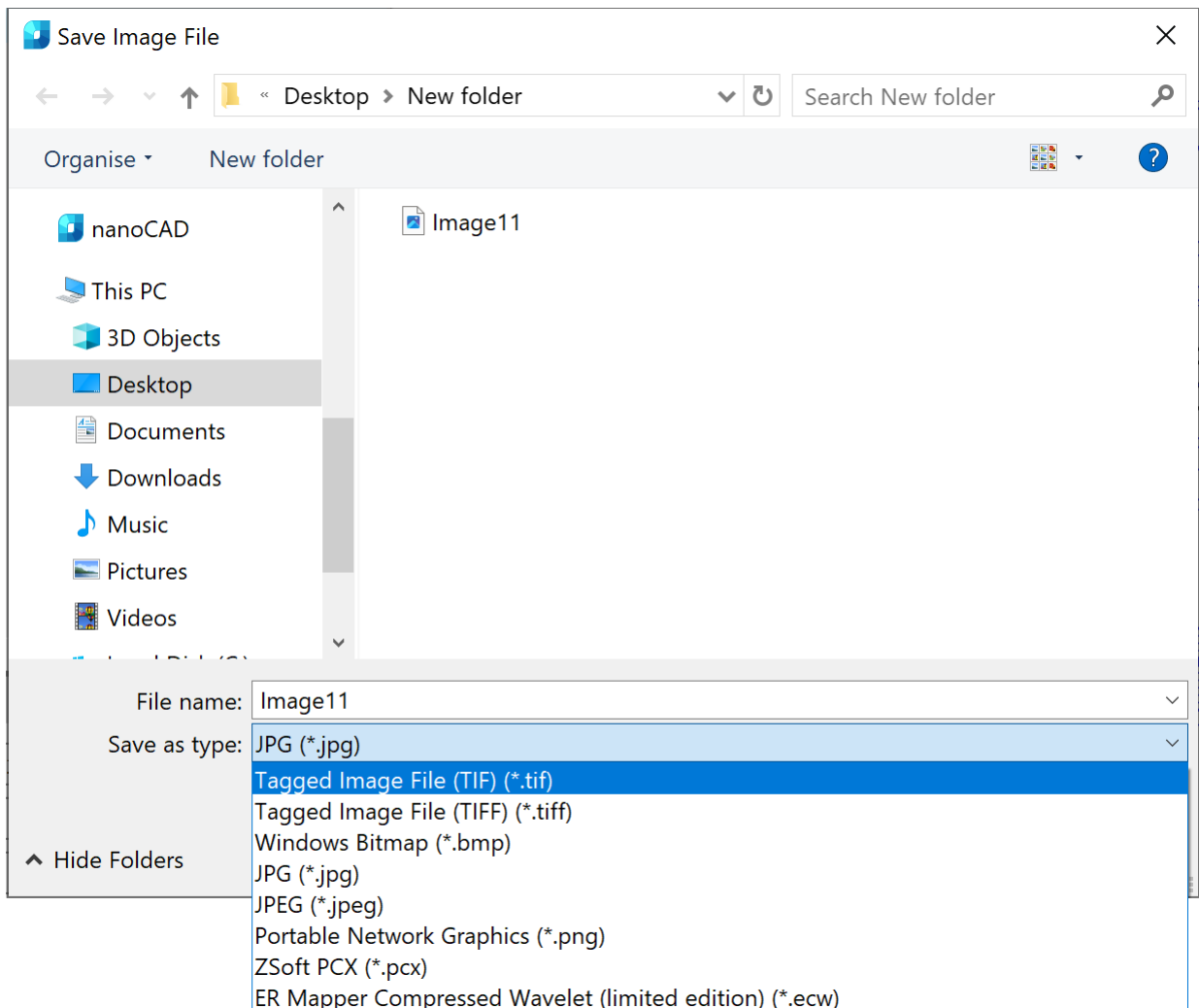

4. Click the **Options** button.
5. In the **TIFF Options** dialog box, set the necessary parameters:

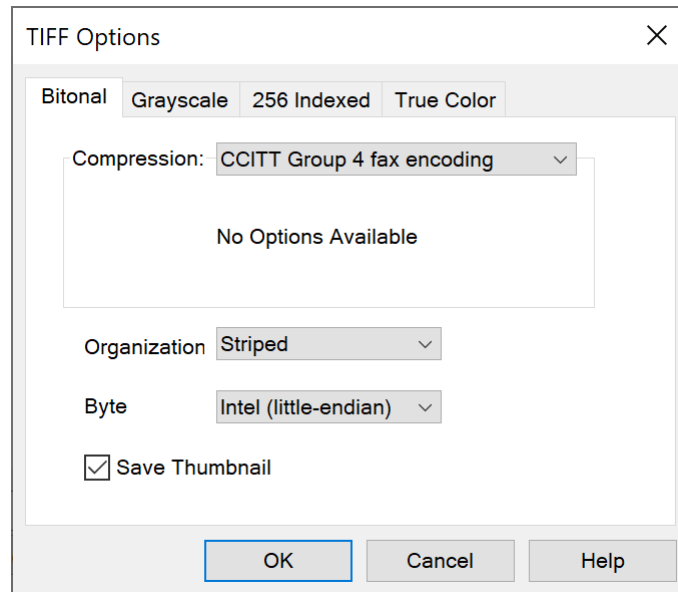

6. Click **OK**.
7. Click **Save**.

## TIFF Saving Options

The settings of this dialog box also apply to other types of **TIFF**-formats, including multiple-page **TIFF** and **TIFF** with geodata.

If part of a multiple TIFF-file includes images of different types, such as color and bitonal, then you can adjust separately for each of these types.

There is a separate tab for each of the color modes. For example, to adjust the saving options for a 256-color image in **TIFF**, it is necessary to use the **256 Indexed** tab.

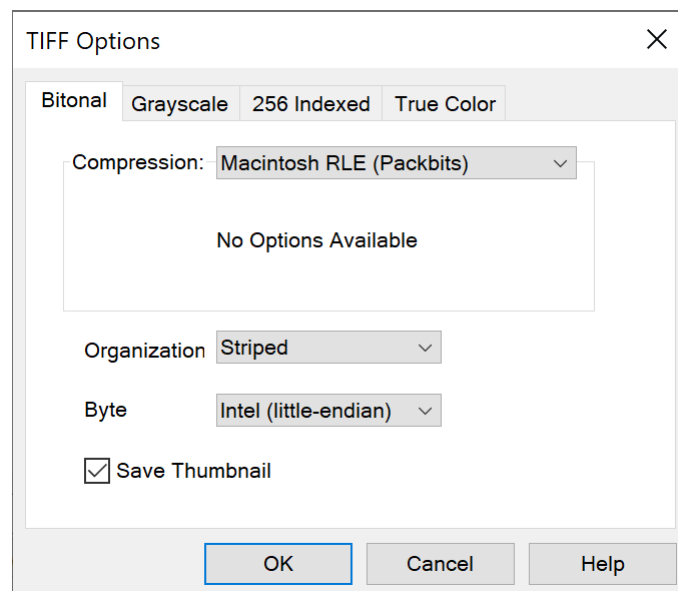

## Options:

### Compression:

Drop-down list to select the raster degree of compression.

Depending on the selected color mode, the following parameters in the list are available:

- **No compression** - Raster is saved without compression. In this case, the file will be of a large size. At the same time the file can be read by any program that supports working with **TIFF**.
- **CCITT modified Huffman RLE** - The compression type, which combines Huffman and RLE algorithms. It is used to compress the bitonal raster images.
- **CCITT Group 3 fax encoding** - The compression type, which uses the Huffman algorithm with a fixed table for compressing bitonal raster images. The following options are available for this compression type:
  - **2-D Encoding** - The most effective data compression.
  - **Fill To Byte Boundary** - Controls the method of defining the line start. When this option is on, a new line always starts with the bits number of a multiple byte.
- **CCITT Group 4 fax encoding** - The compression type that is optimal for the bitonal raster images. It is supported by most raster editors and ensures the best compression of bitonal data.
- **Macintosh RLE (Packbits)** - The compression type that is optimal for color images. It is supported by most raster editors. At the **Striped** or **Tiled** internal organization, the use of this compression type in some cases can give an increase of file size compared to the saved file without compression
- **ZIP (Deflate compression)** - The compression type that uses an algorithm similar to that used in the ZIP archiver. It can be used with any raster types. Versions of the AutoCAD 2005 and earlier don't support reading TIFF-files with ZIP-compression. Versions of the Spotlight 6.0, RasterID 3.0 and earlier also cannot read files of this compression type. In some cases, attempting to open files of this compression type can lead to fatal errors. Use the slider to control the degree of compression:

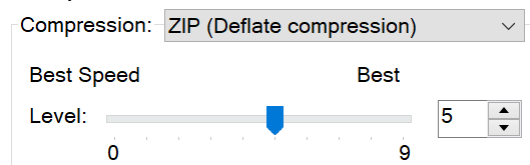

Set the maximum degree of compression to reduce the file size. But this leads to an increase in the time taken for reading/saving the raster image.

- **Lempel-Ziv & Welch** - The compression type that uses a universal compression algorithm without data loss. This algorithm has a high work speed when compressing and when decompressing. The inconvenience is the low degree of compression in comparison with a scheme of two stage encoding. This compression type is used also in GIF and PDF formats.
- **JPEG DCT compression** - The compression type that uses a

JPEG algorithm. The same algorithm is used in the similarly-named JPEG format. It is designed to compress color raster images. It allows the highest degree of compression to be achieved. Also, as described above for the ZIP-compression, JPEG-compression is not supported by all raster editors. JPEG-compression, unlike any other compressions which are used in TIFF-format, is performed with some data loss. This compression type is very useful to create a reduced size file, for example, for Internet transmission. But it is not recommended to use it to store important information. Indeed, whenever you save a TIFF-file to JPEG-compression, recompression is performed, in which the quality of raster deteriorates. Use the slider to control the degree of compression:

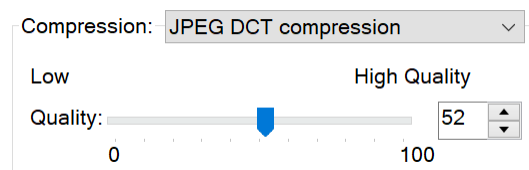

Increasing the degree of compression reduces the file size, but this leads to a reduction of its quality. At the maximum degree of compression you can get raster that may be deformed beyond recognition.

**Organization:**

A drop-down list to select the type of internal organization of the TIFF-file.

The following options are available:

- **Row** – All data within the file are written in one block. This organization type is also called *blocked*. TIFF-files of this organization have the highest compatibility with other programs designed for viewing and editing of raster images.
- **Striped** – All data within the file are written in the form of individual portions of lines. In this way, in some cases, the downloading and viewing of images are accelerated. But in some cases, a combination of the row and striped organization and one of the compression types, for example, Macintosh RLE (Packbits) leads to an increase of the file size instead of the expected reduction.
- **Tiled** – All data within the file are written in the form of fragment, so-called *tiles*. This organization type is not supported by all raster editors. The use of the tile organization can speed up viewing of raster images.

**Byte Order:**

A drop-down list to select the byte order in the word, which is different for PC and Macintosh.

Two options are available:

- **Intel (little-endian)** - Byte order in which the junior (least significant) byte is written first.
- **Motorola (big-endian)** - Byte order in which the senior (most significant) byte is written first.

**Save Thumbnail**

Switching on/off the mode to save a file with a reduced copy of the image (thumbnail).

Thumbnail is used to quickly view the file content in the file open dialog box.

It should be remembered that when you switch on the Save Thumbnail mode, the TIFF-file will be saved as multipage and it cannot be read by

all raster editors.

## JPG and JPEG Saving Options

You can change the degree of compression for JPG and JPEG file formats.

Use the slider to control the degree of compression:

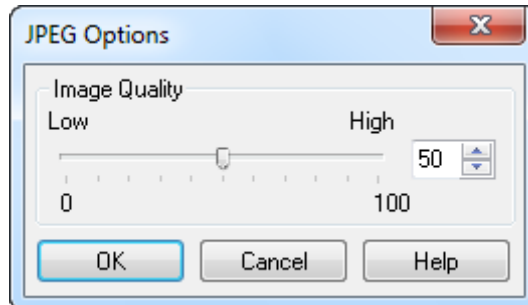

Increasing the degree of compression reduces the file size, but this leads to a reduction in its quality. At the maximum degree of compression you can get a raster that may be deformed beyond recognition.

## Bind External References

When you bind external reference into a current drawing, the reference becomes the part of drawing and converts into a standard block description. There are two ways to bind external reference: binding and insertion.

When external reference binds, descriptions of its named objects (blocks, layers, text and dimension styles, line types) are changing. For example, before binding the layer named HATCH from the Ex\_ref.dwg displayed in dialog **Layers** like Ex\_ref|HATCH. After binding it displayed as follows: Ex\_ref\$n\$HATCH (n=0,1,2,3... - the number increases automatically, if the layer with the same name already exists in the current drawing). Unique names are thus generated in symbol table of current drawing for all descriptions of named objects binding into external reference.

Bind external reference mode is equivalent to the removal xref and subsequent insertion of xref drawing as block to current layer using button **Open** in **Insert block** dialog (menu **Insert – Block**). Names of dependent xref descriptions of named objects in this case are not converted. Redefinition of named object not made if the name of description of binding named object coincides with name of an object that already exists in the drawing. Binded named object inherits properties of exist in current drawing named object. For example, before binding the layer named HATCH from the Ex\_ref.dwg displayed in dialog **Layers** like Ex\_ref|HATCH. After binding of external reference it will have name: HATCH.

### To bind external reference:

1. Select external reference in dialog box **External references**.
2. Show popup menu.
3. Select the command **Bind...**
4. In the box **Bind xrefs** select the bind type: **Bind** or **Insert**.

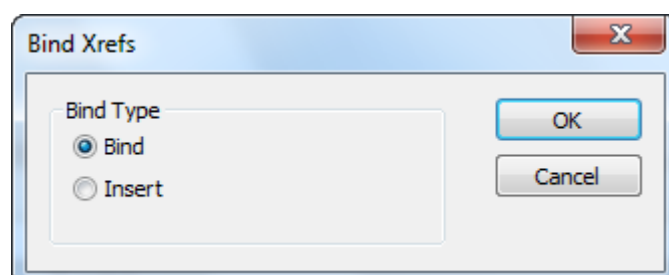

5. Click **OK**.
6. Click the button **Close** to close the dialog **External references**.

## Bind Named Objects of External References



Menu: **Modify – Object** >  **Bind external reference**



Command line: **XBIND, XB**

The command binds into a current drawing descriptions of named objects (blocks, layers, text and dimension styles, line types), which external reference contains.

An inserted external reference contains not only graphical objects (lines, circles, arcs and etc.) but also block descriptions, dimension styles, text styles and line types. Descriptions of named objects of an external reference do not become a part of a current drawing: during every update of an external reference the objects are loaded again from the drawing of the external reference, because descriptions of named objects can change or even delete when a file of external reference is edited. The names of blocks, dimension styles and etc. of an external reference are different from the names of similar objects in a current drawing. A vertical line (|) and a file name of an external reference are placed before named object name belonging to an external reference. For example, a layer having HATCH name of Ext\_reference.dwg external reference file name is displayed as Ext\_reference|HATCH in the **Layers** dialog. If the HATCH layer is deleted from an external reference file, its name disappears in a current drawing. That is why it is forbidden to use named objects of an external reference in a current drawing. For example, it is impossible to insert a block in a current drawing, belonging to an external reference or make a layer, belonging to an external reference, current and create object on it.

To allow using named objects of an external reference in a current drawing it is needed to bind them into a current drawing using the **XBIND** command. Named objects depending on an external reference becomes object of a current drawing after binding, and can be edited and used as named objects of a drawing.

Names of objects of an external reference are modified during binding – a vertical line (|) is changed to two dollar signs, and a value (0 – the first binding, 1 – the second binding etc.) is placed between them. For example, a layer's name of an external reference *Ext\_reference|HATCH* becomes *Ext\_reference\$0\$HATCH* after binding. Binded named objects of an external reference can be renamed in contrast with objects depending on an external reference.

Run **Bind external reference** command

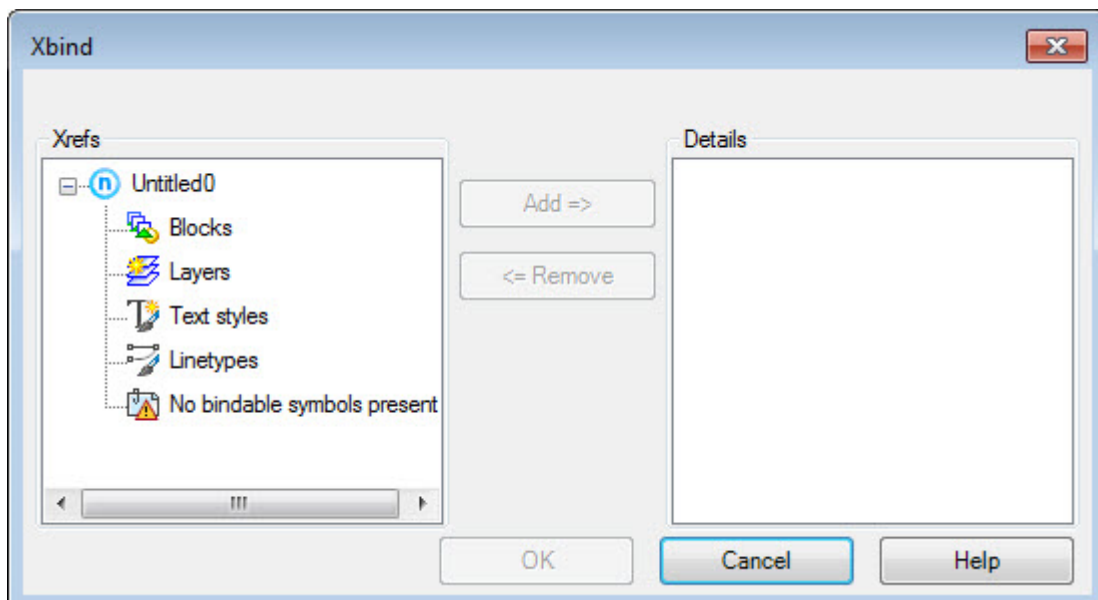

**Parameters:**

**Xrefs** The window contains a structure tree of a current file and shows definitions of named objects, external references and depending definitions of named objects in a file.

**Details** The window shows information about external references and definitions of named object in a current drawing and external references.

**To view information about external reference:**

- Select the link in the **XBIND** dialog:

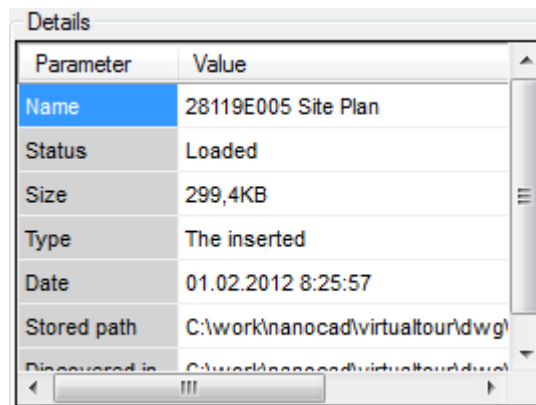

**To view information about definitions of named objects in a current drawing:**

- In the **XBIND** dialog select a required definition of a named object. Names of windows are changed dynamically:

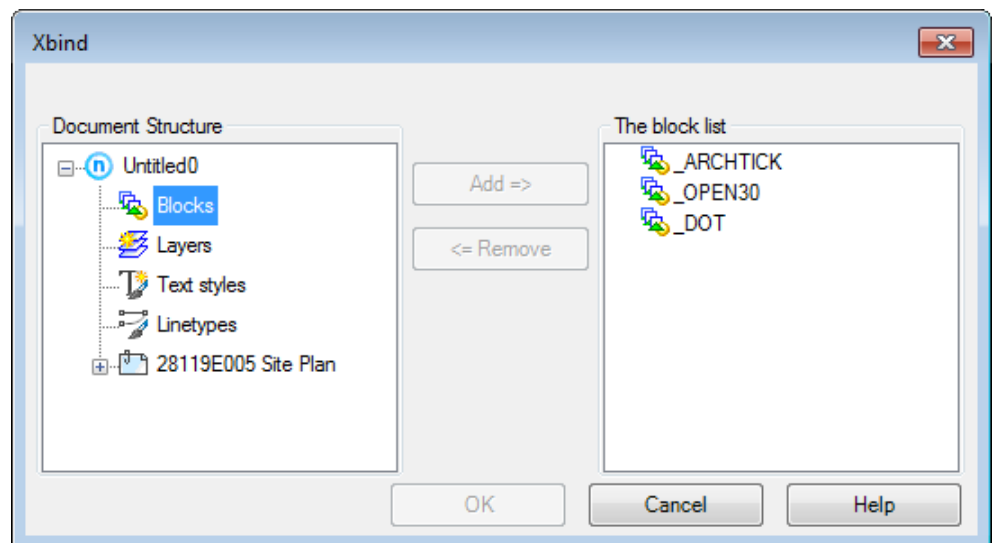

**To select definition of a named object in an external reference:**

- In the **XBIND** dialog select the required definition of a named object of an external reference. Names of windows are changed dynamically:

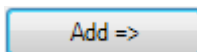
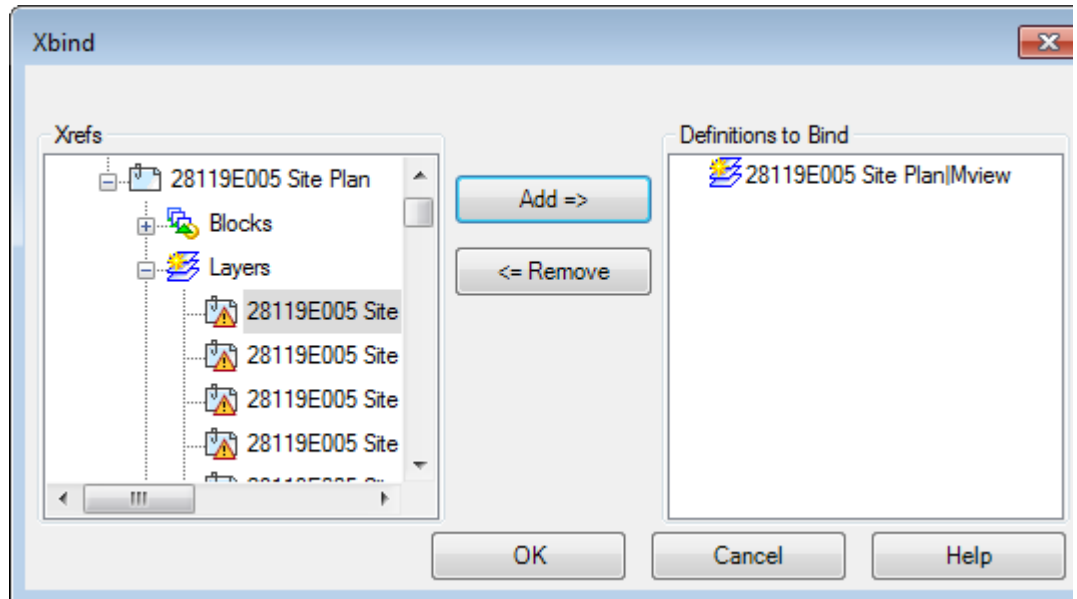

Copies selected definition of the named object of external reference to **Bind** list.

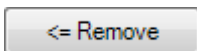

Removes selected definition of the named object of external reference from **Bind** list.

**To bind definitions of named objects into a current drawing from an external reference:**

1. In the **XBIND** dialog **Xrefs** field click on «+» sign to the left of the selected link.

Unfolded branch of a tree contains a list of objects definitions (blocks, line types and text styles).

2. Click the "+" sign to the left of definition name of a named object.

A new branch of a tree contains a list of definitions of a named object.

3. Select a definition of a named object.
4. Click the **Add** button.

Definition of the named object is moving to **Bind** list.

5. Repeat 2, 3 and 4 steps to select other definitions of named objects.
6. You can remove incorrectly added definition from **Bind** list using **Remove** button.
7. To bind selected definitions of named object in a current drawing click the **OK** button.

## External References Notification

While working in a document, changes in the files of external references made by external programs are tracked. Changes in the files of external references (xrefs), underlays, and raster images are tracked.

The status bar displays an indicator button of the status of external links in the active document.



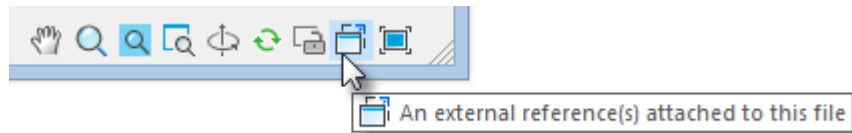

If an external link file was changed in a third-party application while working in the drawing, a warning message will appear and the indicator will change its status.

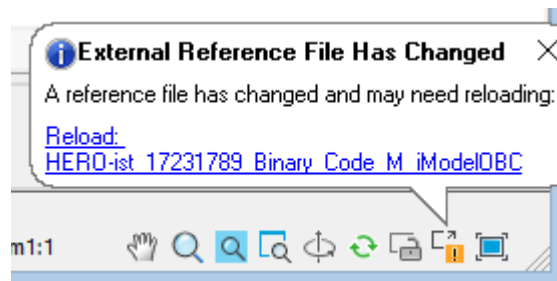

Right-clicking on the button opens a context menu from where you can call the **External Links** dialog box or update the external links of the drawing.

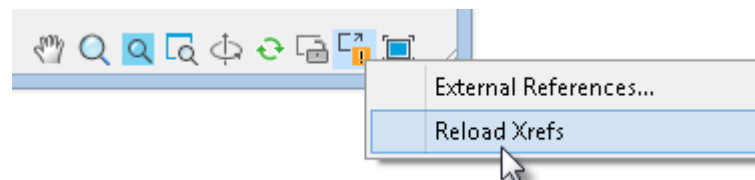

If the external link file was not found at all, the message appears, and the indicator button turns red.

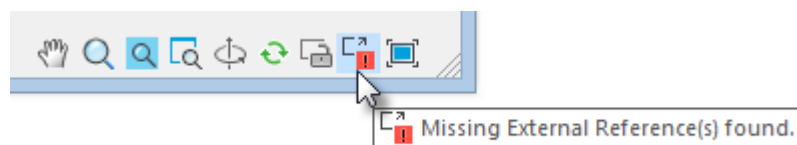

The **XREFNOTIFY** variable allows you to disable notification or change the type of notifications:

- 0 - disable notification of changes of external link files.
- 1 - display notifications in the dialog boxes.
- 2 - display notifications as pop-up balloons near the status bar.

The **XNOTIFYTIME** variable sets the time interval at which external link files are checked (in minutes).

## Renaming Named Objects

Changing names assigned to named objects. It is convenient to use the command to bring such named objects as layers, dimension styles, linetypes, text styles, etc. in conformity with certain naming standards.



Menu: **Format** –  **Rename...**



Command line: **RENAME**

The command opens **Rename** dialog box, which displays the list of drawing elements containing named objects.

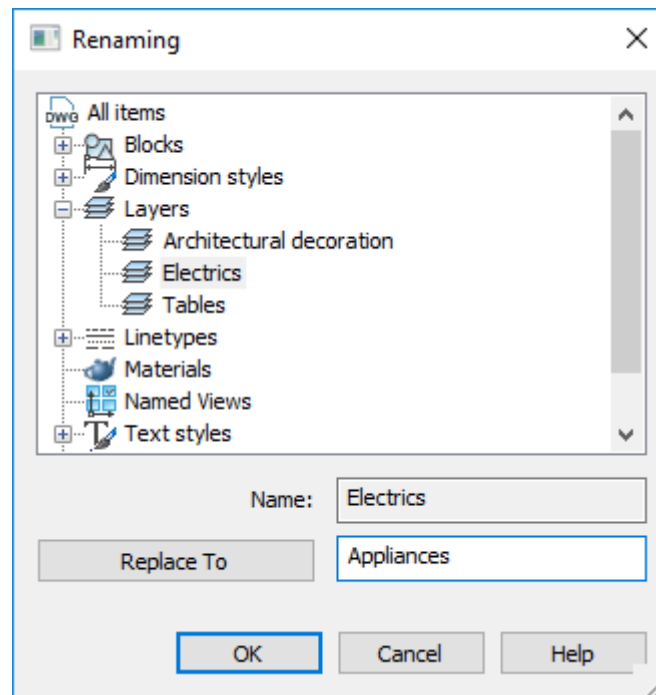

### Renaming procedure

1. Open the element category by pressing **+** icon.
2. Select a named object in the list. The object name will be displayed in the **Name** field.
3. Enter a new name in the field, next to the **Replace to** button.
4. Click the **Replace to** button.
5. Click **OK**.

### Renaming a group of named objects

It is possible to rename only a part of the name that is common for selected objects.

1. Open the element category by pressing **+** icon.
2. Select named objects in the list using **SHIFT** or **CTRL** keys.
3. In the **Common part name** field to leave the part of name common for all objects, which should be replaced.
4. Enter a new value in the field, next to the **Replace to** button.
5. Click the **Replace to** button.
6. Click **OK**.

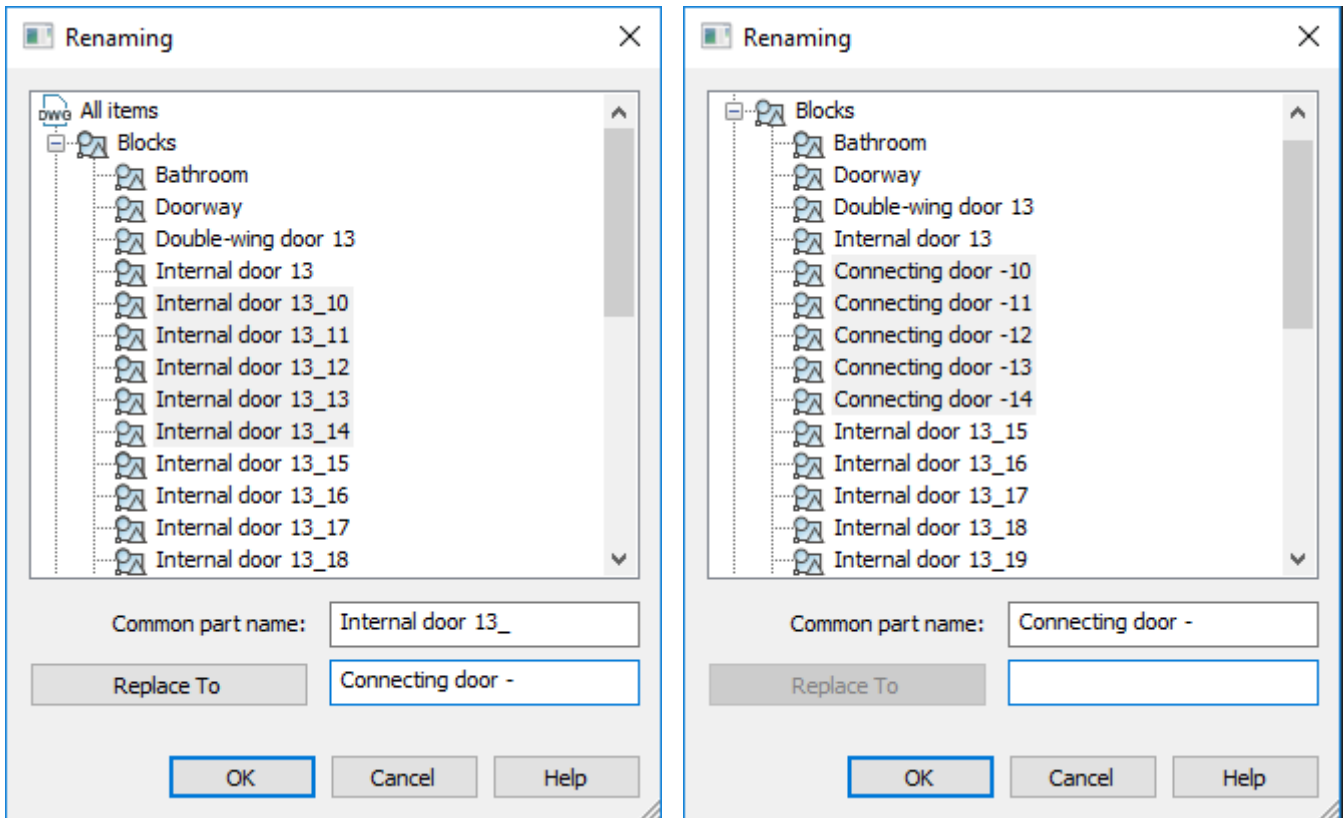

## *Binding and Embedding OLE-Objects*

Binding and embedding objects allows you to use information from one application in another one. To use OLE technology, it is necessary that both the source application and the target application support OLE mechanism.

Both binding and embedding insert information from one document into another. Further, in both cases an object is edited in the document of the receiving application. However the results of binding and embedding objects differ from each other by the method how the information is stored.

Embedding objects and their binding are similar to inserting blocks and creating external references.

### **Embedding objects**

When embedding by OLE method, a copy of embedded data is placed in the compound document. This copy loses contact with the source document. Embedded data in the compound document can be edited using the application they were created in; but the source document does not change. When embedding objects, the link with the source file is not maintained. Embedding should be used, if modification of the source document while editing the compound document is undesirable.



### **Binding objects**

When binding by OLE method, a link is created between the server document and the compound document. A link is a convenient way to use the same data in different documents: if the source data are modified, only update of links is required to change the compound documents. Most receiving applications can also be configured to update them automatically.

When linking a drawing, you should maintain access to both the source application and the document. If any of them are renamed or moved, the link may need to be re-defined.

**NOTE:** Copying of the current view to the clipboard for linking with other OLE applications is performed by the [Copy OLE-link](#) command.

## Insert OLE-Object

-  Ribbon: **Insert – Data** >  **Insert OLE-object**
-  Menu: **Insert** –  **OLE-object**
-  Command line: **INSERTOBJ**

The command allows you to insert linked or embedded OLE-objects into the drawing





**NOTE:** Linked data inserted into a drawing field from another document can be updated in accordance with their changes in the source document. Embedded data cannot be updated in a drawing field in case they are changed in the source document.

The **Insert Object** dialog box will open.

### Options:

<b>Create new</b>	Runs the application selected in the <b>Object type</b> list to create a new object for insertion.
<b>Object type</b>	A list of applications that support OLE technology. To create an embedded object, double-click the appropriate application in the list. In the application that opens, the <b>Save</b> item from the <b>Main</b> menu is replaced by <b>Update</b> . When this item is selected, the object is inserted into the drawing or updated. In addition
<b>Create from file</b>	Selects the linked or embedded file.
<b>File</b>	Specifies the name (including the path) of embedded or linked file.
<b>Review</b>	Opens the standard file selection window, in which select the file to be embedded or linked.
<b>Link</b>	Linking (not embedding) the specified file.
<b>As an icon</b>	Displays the source application icon in the drawing. The embedded/linked information is open after double-click by the left mouse button on the icon.

## Open OLE-Object

-  Ribbon: **Insert – Data** >  **Open OLE-object**
-  OLE-object: double-click on the object
-  Command line: **OLEOPEN**

Opens the selected OLE-object in the source application for editing.

A drawing from another application, which is *linked* in the document, stores information about the location of the linked drawing file, and it cannot be modified in the source and target application.

A drawing, which is *embedded* in the document from another application, can be edited only in the target application.

## Update OLE-Links



Ribbon: **Insert – Data** >  **Update data links**



Menu: **Edit** –  **OLE-links**



Command line: **OLELINKS**

Update, change and cancel the selected linked OLE-object

### Options:

<b>Links</b>	Contains information about linked objects. The type of information depends on the type of the linked object. To change information about the linked object, select it in the list.
<b>Source</b>	Displays the path to file containing the linked object and the type of this object.
<b>Type</b>	Displays the name of application the linked object is created in.
<b>Update: Auto</b>	Enables automatic update of the linked object in the current drawing in case of any modifications in the source application.
<b>Update: Manual</b>	Enables the request to confirm the need to update links when opening a drawing containing linked objects.
<b>Update now</b>	Updates links selected in the list.
<b>Open source</b>	Opens the source file and marks its part linked with the current drawing.
<b>Change source</b>	Opens the dialog box for selecting files, using which you can specify other source files. If the linked object is a part of the source file (not the whole file is selected), then a line identifying the selected element will appear.
<b>Break link</b>	Breaks the link between the linked object and its source file. Further modifications of the source file do not influence on this object in the drawing.

## Update All OLE-Links



Menu: **Edit** –  **Update All OLE-links**



Command line: **OLEUPDATEALLLINKS**

The command updates simultaneously all linked OLE-objects in a document.

## Underlays

nanoCAD supports DWF, DWFx, PDF files insertion as underlays. Editing commands like **Copy**, **Move**, **Rotate**, **Mirror**, **Scale**, and others are available for underlays.

**Properties** dialog box displays some underlay settings: Contrast, Fade, Adjust colors for background, monochrome:

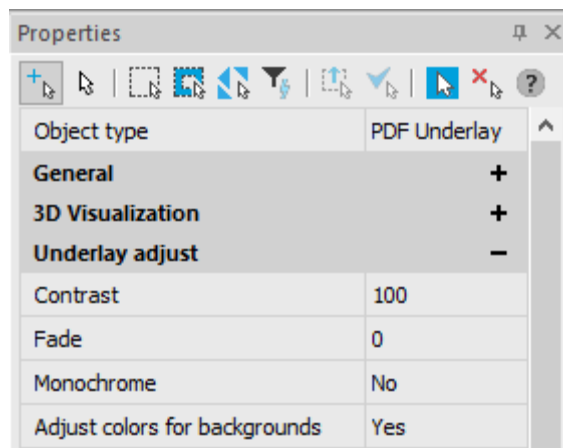

Underlay in the drawing has one grid in the bottom left corner. Use it to move the underlay.

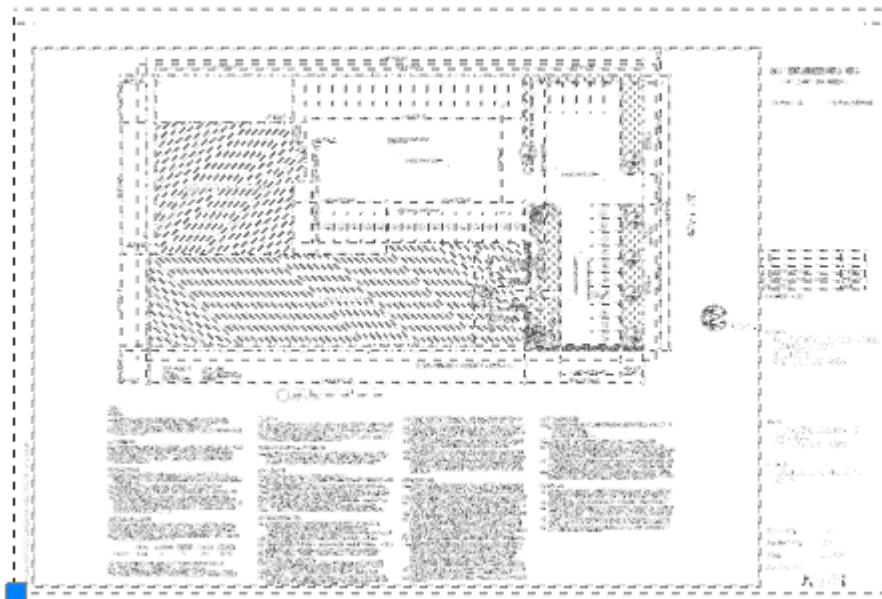

Underlay has a frame that shows max underlay size. Use **PDFFRAME** system variable to show (**1**) or hide (**0**) a frame.

It is possible to set the display border to show only the cropped part of the background. Trimming is performed with the [UNDERLAYCLIP](#) command.

## Insert Underlay



Ribbon: **Insert – Reference** >  **Underlay...**



Menu: **Insert** >  **Underlay...**



Command line: **UATTACH**

Insert DWF, DWFX or PDF underlays to the drawing. In case of using C3D graphics core, the following 3D formats can be inserted:

Format	Version
Parasolid (*.x_t; *.x_b)	25.0
IGES (*.igs; *.iges)	5.3
STEP (*.step; *.stp)	203, 214
ACIS (*.sat)	22.0
VRML (*.wrl)	2.0
STL (*.stl)	-

**NOTE:** Date from inserted PDF underlays can be further converted into a document by the [Convert PDF](#) command.

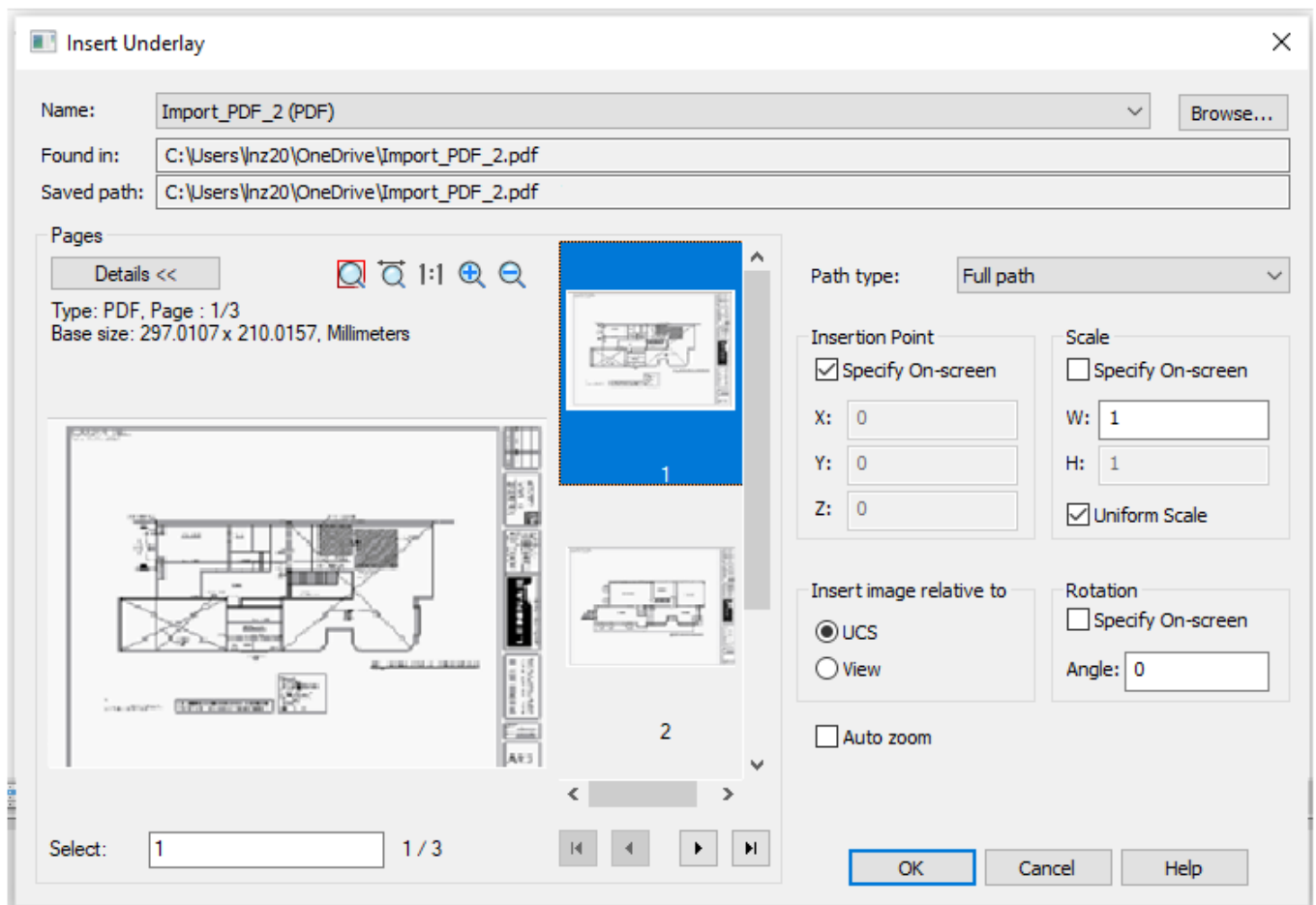

### Options:

- Name:** List of inserted underlays' names.  
 Opens **Select Underlay file** dialog to select and insert new underlay.
- Found in** Displays information about the path by which the underlay file was found.
- Saved path:** Displays information about the saved path to the underlay file.

**Path type:**

Information about path of underlay file. Variants:

- **Full path**
- **Relative path**
- **No path**

*Insertion point*

**Specify on-screen**

Selects the insertion point after the dialog box is closed.

**X: Y: Z:**

Specifies the point coordinates for the underlay insertion.

*Scale*

**Specify on-screen**

Specifies the scale of underlay after the dialog box is closed.

**W:**

Width scale factor.

**H:**

Height scale factor.

**Uniform scale**

Specifies the scale factor for the Width or Height values. A value specified for Width is also reflected in the Height value.

*Rotation*

**Specify on-screen**

Specifies the rotation angle for the inserted underlay, using the pointing device.

**Angle:**

Sets the rotation angle for the inserted underlay.

*Insert image relative to*

**UCS**

Sets the insert underlay mode relative to the User Coordinate System (UCS).

**View**

Sets the insert underlay mode relative to the World Coordinate System (WCS).

**Auto zoom**

Switches on/off the full screen mode of the inserted underlay.

*Pages*

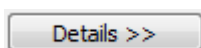

Shows/hides underlay page information (type, size, layer).

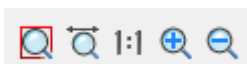

Zoom and pan buttons in preview dialog.

**Selected**

Numbers of selected pages to insert.



Buttons for transition between pages in underlay.

## Show Boundary

This option shows a set of raster images, blocks or external references in the enclosed area. (see "Set show boundary for a viewport" section).

The show boundary defines the visibility of objects in the current document. The original objects are not changed.

Setting of the clip boundary is achieved using the clipping contour.

Clipped blocks or external references, raster images and viewports can be edited as well as unclipped ones.



Tools to work with boundaries are located:  
on the **Insert** ribbon tab in the **Reference** section:

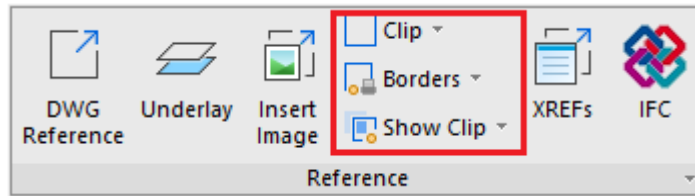

and in the menu: **Modify – Clip:**

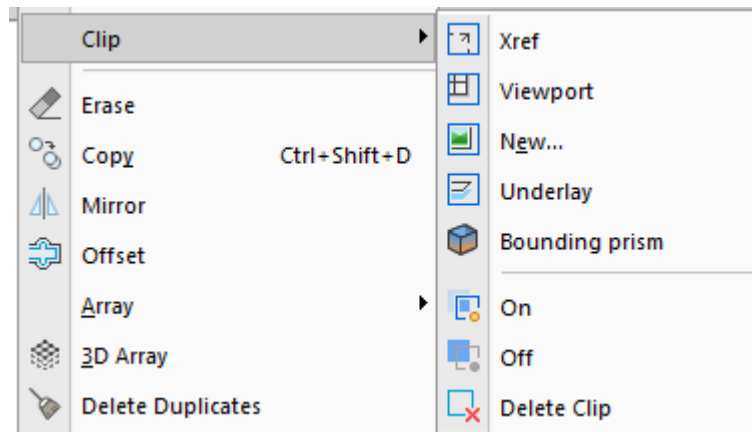

## Show Clip



Ribbon: **Insert – Reference – Show Clip**



Menu: **Modify – Clip**



### Show Clip ON

Displays the clipped insertion fragment.



### Show Clip OFF

Displays a full insertion.

## Show Clipping Borders

The form and size of clip contour can be changed using grips located in the contour vertices.  
Commands to manage the display of clip borders:



Ribbon: **Insert – Reference – Borders >**



### Show but not Print Borders



### Show and Print Borders



### Hide Contours

## Setting Clip



Ribbon: **Insert – Reference – Clip** >  **Object clip**



Command line: **CLIP**

The general command for setting a clip allows you to select any of the below objects to overlay the display area:

- [block reference or external reference](#);
- [viewport](#);
- [raster image](#);
- [underlay](#).

### Inverting the display of clip data

For quick display of the data contained outside the clipping, use an arrow grip . The grip is located in the middle of the first edge of the clip contour.

The original image of the xref.

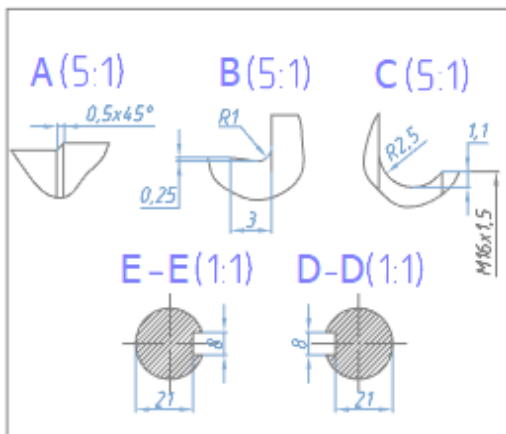

The selected display border is highlighted with grips.

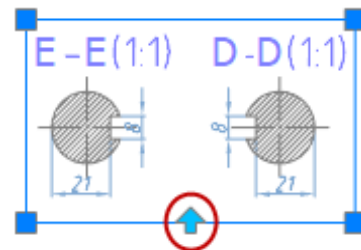

Clicking the arrow grip turns off visibility of the clipping data and turns on visibility of the hidden parts of the clipped reference.

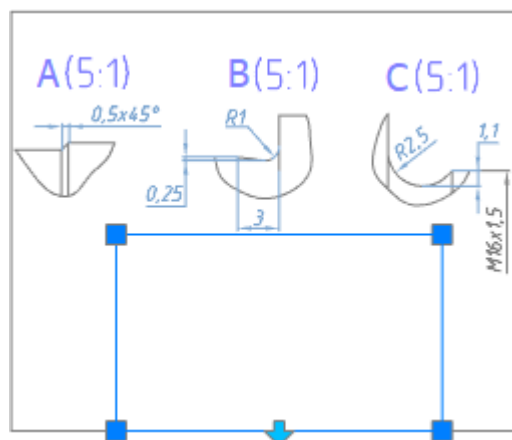

The repeated click on the arrow returns the display of the clipped fragment.

## Setting of the Show Boundary for the Block or External Reference

 Ribbon: **Insert – Reference – Clip** >  **XReference Clip**

 Menu: **Modify – Clip** >  **XRef**

 Command line: **XCLIP**

The command sets the clipping contour of the show boundary to display the section of the inserted block or external reference.

When a block or external reference is selected, the command to show boundary becomes available from the context menu for your convenience:

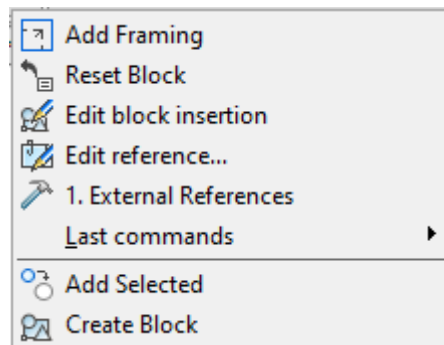

The command doesn't change the objects of the block or external reference (the definition of the block or external reference remains unchanged). Creation of the clipping contour affects only the display block or an external reference in the current document.

If a block or external reference has been inserted more than once, it is possible to specify different clipping contours for each entry, but each entry can have only one contour.

Clipping of the block or external reference is carried out by a polygonal contour: rectangle, polygon or closed polyline.

The **XCLIPFRAME** system variable is designed to set the visibility of the boundary of the clipping contour. If the system variable is set to a value of 1, the boundary of the clipping contour will be displayed on the screen. You can select it and print it out. If the system variable is set to a value of 0, the visibility of the boundary will be turned off (set by default).

Display of the boundary of the clipping contour is turned on

(system variable **XCLIPFRAME = 1**)

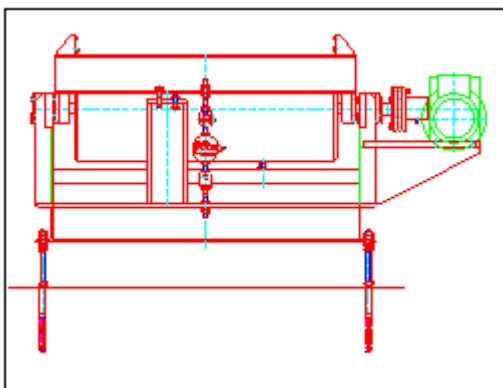

Display of the boundary of the clipping contour is turned off

(system variable **XCLIPFRAME = 0**)

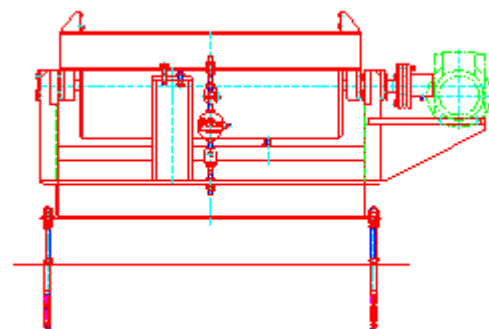

You can turn off the clipping of the block or external reference to display the full entry and then turn it on again to display only the clipped area.

A clipped section of the block or external reference can be copied, moved and rotated in the same way as an entry of the block or external reference that is not clipped. The clipping contour is copied, moved or rotated with the entry.

The clipping options also extend to attached references: when the main reference is clipped, all attached references will be clipped too.

The clipping contour can be redefined. Set the new clipping contour to remove the old contour.

After removing the clipping contour, the block or external reference is displayed on the screen in full.

### Options:

- ? Calls additional options to select the objects.
- On Mode displays a clipped section of the block or external reference.
- Off Mode displays the full entry of the block or external reference.
- Clip depth Sets near and far clipping planes for the external reference or block. Objects beyond the limit of the contour set by planes of the space will not be displayed on the screen.  
This option calls the following prompt in the command line:  
Specify point for front clipping plane or [Distance/Remove]:  
**Options:**  
Distance - Create a clipping plane, passes at a prescribed distance parallel to the clipping contour.  
Remove - Delete near and far clipping planes.
- Delete Deletes the clipping contour for the selected entry of the block or external reference.  
This option deletes the clipping contour and clipping plane.
- Generate Polyline Automatically creates a polyline whose vertices match the vertices of the clipping contour.  
This option is used to change the current clipping contour: the created polyline is edited by the **PEDIT** command (the **Modify** menu – **Object > Polyline**). Then the edited polyline is used to change the existing clipping contour so that it is based on the new contour.
- New Creates a new clipping contour.  
This option calls the following prompt in the command line:  
[Select polyline/Polygonal/Rectangular] <Rectangular>:  
**Options:**  
Select polyline - Set the limits contour by the selected closed polyline. The polyline should be created previously and consist of straight-line segments.  
Polygonal - Set the polygonal contour of the show boundary by sequenced specifying of the polygonal vertices.  
When you set the second and next vertices, you can see the following prompt in the command line *Specify next point or [Undo]*:  
Undo - Sequenced cancelling of the specified points of the polygonal vertices. Specified first point cannot be cancelled.  
Rectangular - Set the rectangular contour of the show boundary by sequenced specifying of the opposite rectangular vertices.

External reference before setting of the show boundary

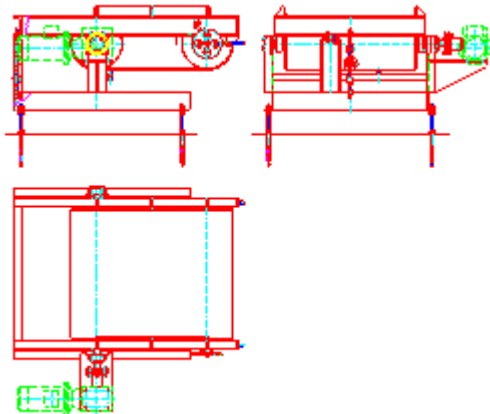

External reference after the setting of the show boundary

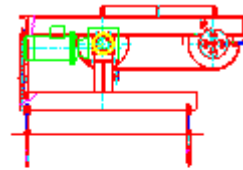

**The command prompts when you specify a rectangular boundary:**

Select block or X-references or [?]:

Enter clipping options  
[ON/OFF/Clip\_depth/Delete/generate\_Polyline/New]  
<New>: N

[Select polyline /Polygonal/Rectangular]  
<Rectangular>:

Specify first corner:

Specify opposite corner:

Select the block or reference and press **ENTER**.

Choose New or press **ENTER**.

Press **ENTER**.

Specify the first corner.

Specify the opposite corner.

**The command prompts when you specify a polygonal boundary:**

Select block or X-references or [?]:

Enter clipping options  
[ON/OFF/Clip\_depth/Delete/generate\_Polyline/New]  
<New>: N

[Select polyline /Polygonal/Rectangular]  
<Rectangular>:

Specify first point:

Specify next point or[Undo]:

...

Specify next point or[Undo]:

Select the block or reference and press **ENTER**.

Choose New or press **ENTER**.

Choose Polygonal.

Specify the first point.

Specify the second point.

...

Specify the end point and press **ENTER**.

**The command prompts when you specify a boundary by polyline:**

Select block or X-references or [?]:

Enter clipping options

Select the block or reference and press **ENTER**.

Choose New or press

```
[ON/OFF/Clip_depth/Delete/generate_Polyline/New]
<New>: N
[Select_polyline /Polygonal/Rectangular]
<Rectangular>:
Select_polyline:
```

**ENTER**.

Choose Select  
polyline.

Select polyline.

#### To turn on/off clipping of the block or external reference:

1. In the **Modify** menu click **Clip** and then **On** or **Off** commands.
2. In reply to the prompt in the command line `Select block` or `X-references` or `[?]`: Select the entry and press **ENTER**.

#### To change the clipping contour of the block or external reference:

1. In the **Modify** menu click **Clip** and then the **New** command.
2. In reply to the prompt in the command line `Select block` or `X-references` or `[?]`: Select the entry and press **ENTER**.
3. In reply to the prompt in the command line `Delete old boundary(s)?` `[Yes/No]` `<Yes>`: Select Yes or press **ENTER**.
4. In reply to the prompt in the command line `[Select_polyline/Polygonal/Rectangular]` `<Rectangular>`: Select the required option and set the new clipping contour.

**NOTE!** It is possible to create a new clipping contour if the old contour is deleted.

#### To delete the clipping contour:

1. In the **Modify** menu click **Clip** and then **Delete** command.
2. In reply to the prompt in the command line `Select block` or `X-reference` or `[?]`: Select entry and press **ENTER**.

## Setting of the Show Boundary for a Raster Image



Ribbon: **Insert –Reference – Clip** >  **Image Clip**



Menu: **Modify – Clip** >  **New**



Command line: **IMAGECLIP, ICL**

The command allows you to insert a clip of the raster image into the drawing, to set the display on the screen and print only the required part of the raster image.

When a raster image is selected the command to show boundary becomes available from the context menu for your convenience:

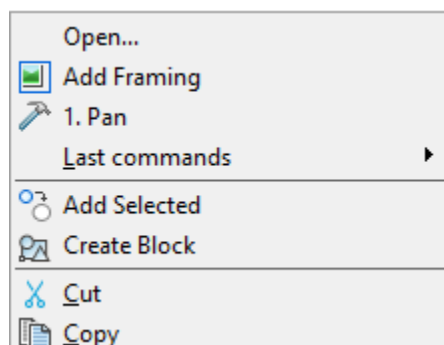

Setting of the show boundary of the raster image affects its display in the current document, but does not change the source image.

Clipping of the raster image is done using a polygonal outline (rectangular, polygonal or closed polyline), whose vertices are inside the image boundary.

It is possible to specify a different clipping contour for each entry of the same raster image, but each entry can have only one contour.

The clipping contour can be turned off to display the original image and then back on to show the clipping image.

The clipping contours can be redefined. When you specify a new clipping contour, the old contour should be deleted.

After deleting the clipping contour, the raster image is displayed on the screen in its original boundaries.

The **IMAGEFRAME** system variable allows you to manage the visibility of the clipping contour and raster counter. If the system variable is set to value *1* (set by default), the counter is displayed on the screen and you can select it and print it. If system variable is set to value *0*, the counter visibility is turned off and you cannot select it and print it. If system variable is set to value *2*, the counter is displayed on the screen, but you cannot print it.

There are commands in the **Modify** menu – **Object** > **Image** > to make work with **IMAGEFRAME** system variable easier:

**Frame On** - Sets **IMAGEFRAME** = **1**

**Frame Off** - Sets **IMAGEFRAME** = **0**

**Print Off** - Sets **IMAGEFRAME** = **2**

**Options:**

- ? Calls additional options to select the objects.
- Select polyline Sets the limits contour using the selected closed polyline. The polyline should be created previously and consist of straight-line segments.
- Polygonal Sets the polygonal contour of the show boundary by sequenced specifying of the polygonal vertices. When you set the second and next vertices, you can see the following prompt in the command line:  
Next point or [Undo]:  
**Option:**
- Undo Sequenced cancelling of the specified points of the polygonal vertices. Specified first point cannot be cancelled
- Rectangular Sets the rectangular contour of the show boundary by sequenced specifying of the opposite rectangular vertices.

Setting the rectangular contour of the show boundary of the raster image

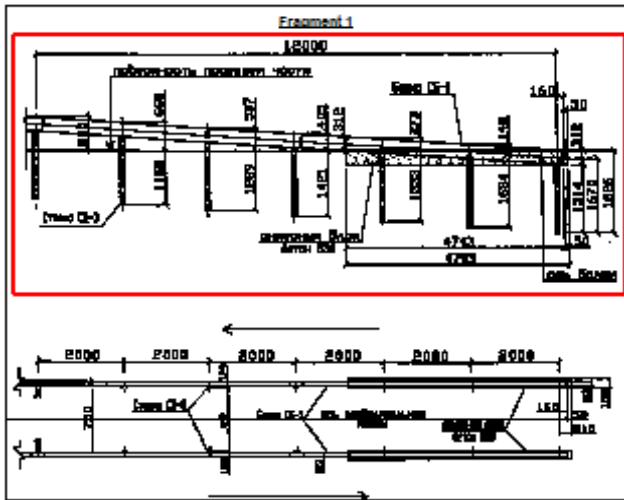

Displaying of the raster image after setting the show boundary

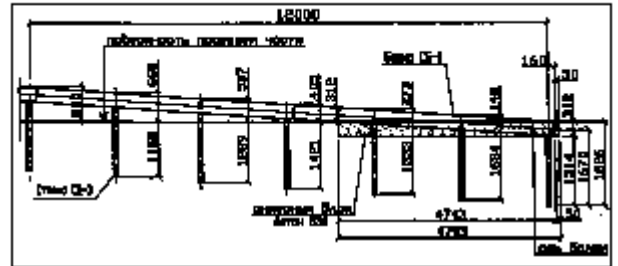

**The command prompts when setting the rectangular boundary:**

Select block or X-references or [?]:

[Select polyline /Polygonal/Rectangular]  
<Rectangular>:

Specify first corner:

Specify opposite corner:

Select raster and press **ENTER**.

Press **ENTER**.

Specify the first corner.

Specify the opposite corner.

**The command prompts when setting the polygonal boundary:**

Select block or X-references or [?]:

[Select polyline /Polygonal/Rectangular]  
<Rectangular>:

Specify first point:

Specify next point or [Undo]:

...

Specify next point or [Undo]:

Select raster and press **ENTER**.

Select Polygonal.

Specify the first point.

Specify the second point.

...

Specify the end point and press **ENTER**.

**The command prompts when specifying a boundary by a polyline:**

Select block or X-references or [?]:

[Select polyline /Polygonal/Rectangular]  
<Rectangular>:

Select\_polyline:

Select raster and press **ENTER**.

Choosez Select polyline.

Select the polyline..

**To turn on/off the clipping contour:**



1. In the **Modify** menu, click **Clip** and then the **On** or **Off** commands.

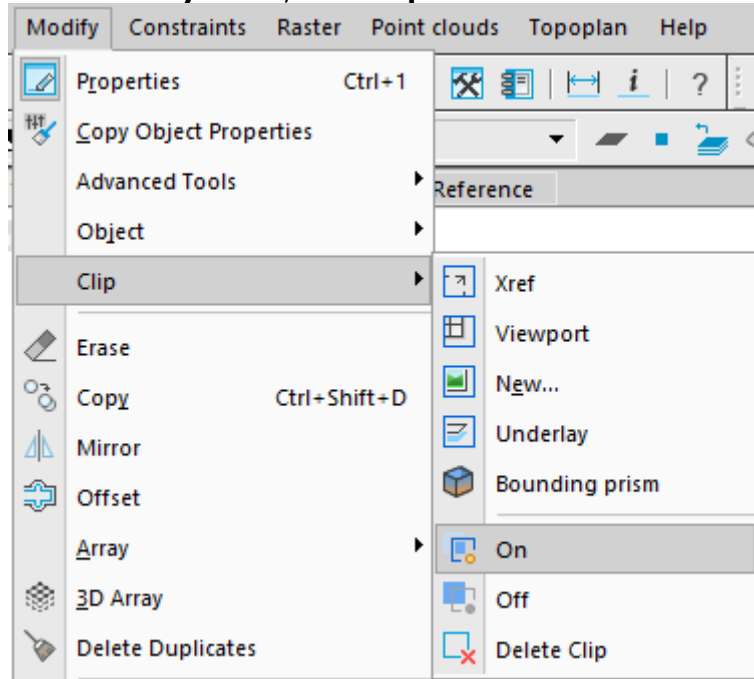

2. In reply to the prompt in the command line *Select block or X-references or [?]*: Select the raster image and press **ENTER**.

You can also switch the clip show in another way: select a raster image and switch **Show Clipped** option in the **Properties** bar.

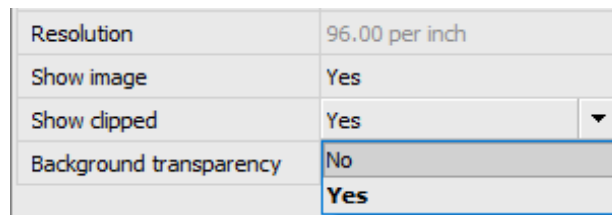

#### **To change the clipping contour:**

1. In the **Modify** menu, click **Clip** and then the **New** command.
2. In reply to the prompt in the command line *Select block or X-references or [?]*: Select the raster image and press **ENTER**.
3. In reply to the prompt in the command line *Delete old boundary(s)? [Yes/No] <Yes>*: Select **Yes** or press **ENTER**.
4. In reply to the prompt in the command line *[Select polyline/Polygonal/Rectangular] <Rectangular>*: Select the required option and set the new clipping contour.

**NOTE!** It is possible to create a new clipping contour if the old contour is deleted.

#### **To delete the clipping contour:**

1. In the **Modify** menu, click **Clip** and then the **Delete** command.
2. In reply to the prompt in the command line *Select block or X-references or [?]*: Select the raster image and press **ENTER**.

## Setting Viewport Border for Underlay

 Ribbon: **Insert – Reference – Clip >**  **Underlay Clip**

 Menu: **Modify – Clip >**  **Underlay**

 Command line: **UNDERLAYCLIP**

The command allows you to clip underlays inserted in a drawing so that only its desired part is displayed on the screen and plotted.

In pre-selection of the underlay for more convenient work the command of setting the viewport border becomes available in the context menu:

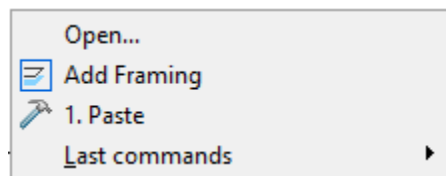

Setting the underlay viewport border impacts only on its display in the current document, the underlay itself is not changed.

The underlay clip is identical to the clip of a bitmap image and is carried out by using a polygon contour (rectangle, polygon or closed polyline), whose vertices lie inside the image border.

It is acceptable to assign different clip boundaries for different underlay insertions, but each insertion can have only one boundary.

The underlay clip can be disabled to display the original image, and then enabled again to display the clipped image. The clipping boundaries can be overridden. When setting a new clipping boundary, the old boundary should be deleted.

After deleting the clipping boundary, the underlay is displayed on the screen in its original boundaries.

To control the display of the underlay boundary, use the system variables **PDFFRAME** and **DWFFRAME** – depending on the type of underlay file. The variable value **0** disables the display of underlay boundary. To enable the boundary display, you should assign **1** value to the variable. When assigning **2** value to the system variable, the boundary is displayed but not printed.

### Command options:

- ? Opens additional options for selecting objects.
- Select polyline Defines the boundary with the selected polyline. The polyline should be created in advance and cannot intersect itself. For arc segments of the polyline, their chords are used as a clipping boundary.
- Polygonal Defines a polygonal clipping boundary by sequential specifying the polygon vertices.  
When specifying the second and the next vertex points, the command line displays the prompt:  
Next point or [Undo]:  
**Option:**  
Undo - Sequential cancellation of the specified points of polygonal area vertices.
- Rectangular Defines a rectangular border of display boundary by specifying the opposite corners of the rectangular.

Defining rectangular border of display boundary

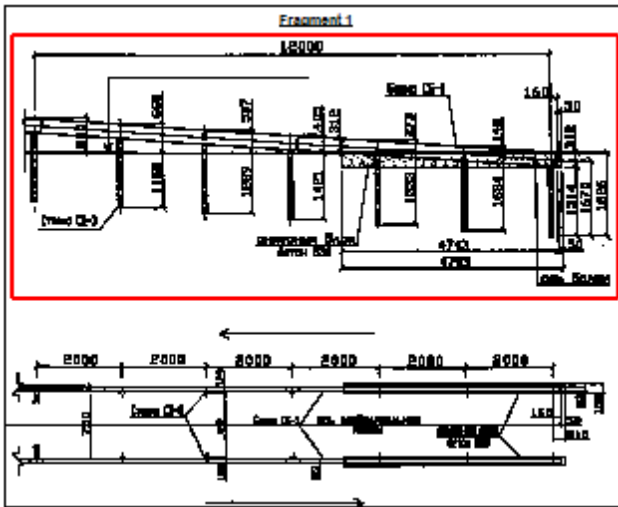

Displaying underlay after defining display boundary

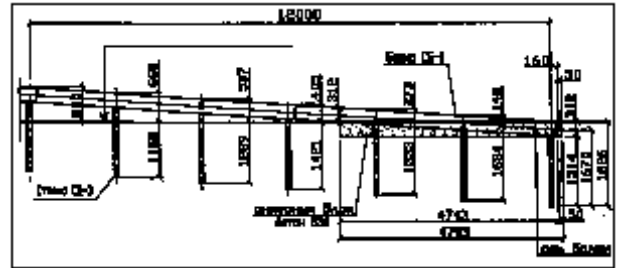

**Command queries when defining a rectangular border:**

Select a block or X-reference or [?]:

[Select polyline/Polygonal/Rectangular]  
<Rectangular>:

Define the first corner:

Opposite corner:

Select bitmap, press **ENTER**.

Press **ENTER**.

Define the first corner.

Define the second corner.

**Command queries when defining a polygonal border:**

Select a block or X-reference or [?]:

[Select polyline/Polygonal/Rectangular]  
<Rectangular>:

First point:

Next point or [Undo]:

...

Next point or [Undo]:

Select bitmap, press **ENTER**.

Select option Polygonal.

Define the first point.

Define the second point.

...

Define the last point and press **ENTER**.

**Command queries when defining a polyline border:**

Select a block or an external reference or [?]:

[Select polyline/Polygonal/Rectangular]  
<Rectangular>:

Select polyline:

Select bitmap, press **ENTER**.

Select option Select polyline.

Select the option.

**To enable/disable clipping:**

1. In the menu **Modify – Clip** select **ON** or **OFF** command.

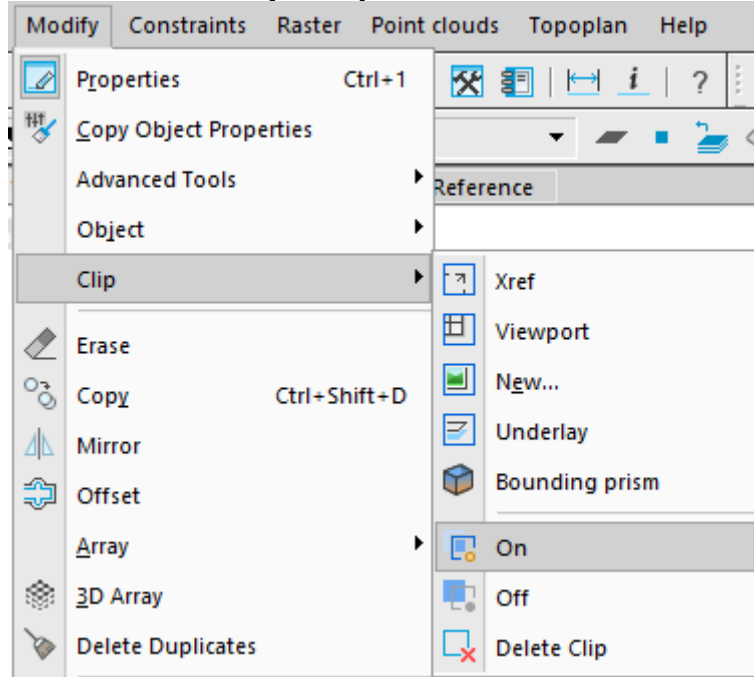

2. In response to the query in the command line `Select block or external reference or [?]`: specify underlay and press **ENTER**.

It is also possible to switch the clipping display in another way: select the underlay and switch the **Display Clipped** option on the **Properties** panel.

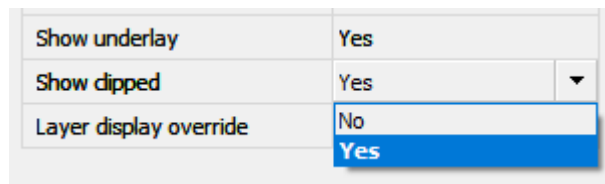

#### To modify the clipping boundary:

1. In the menu **Modify – Clip** select the **New** command.
2. In response to the query in the command line `Select block or external reference or [?]`: specify underlay and press **ENTER**.
3. In response to the query in the command line `Delete the previous boundary(ies)? [Yes/No] <yes>`: select **Yes** option or press **ENTER**.
4. In response to the query in the command line `[Select polyline/Polygonal/ Rectangular] <Rectangular>`: select the relevant option and define a new clipping boundary.

**ATTENTION!** It is possible to create a new clipping boundary only if the old one is deleted.





#### To delete the clipping boundary:

1. In the menu **Modify – Clip** select the **Delete** command.
2. In response to the query in the command line `Select block or external reference or [?]`: specify underlay and press **ENTER**.

## Insert Map Underlay



Ribbon: **Insert – Maps** >  **Insert map**

-  Ribbon: **Topoplan – Maps** >  **Insert Map Underlay**
-  Menu: **Topoplan – Maps** >  **Insert Map Underlay**
-  Command line: **MAPVIEW**

Inserts map underlay into the current drawing.

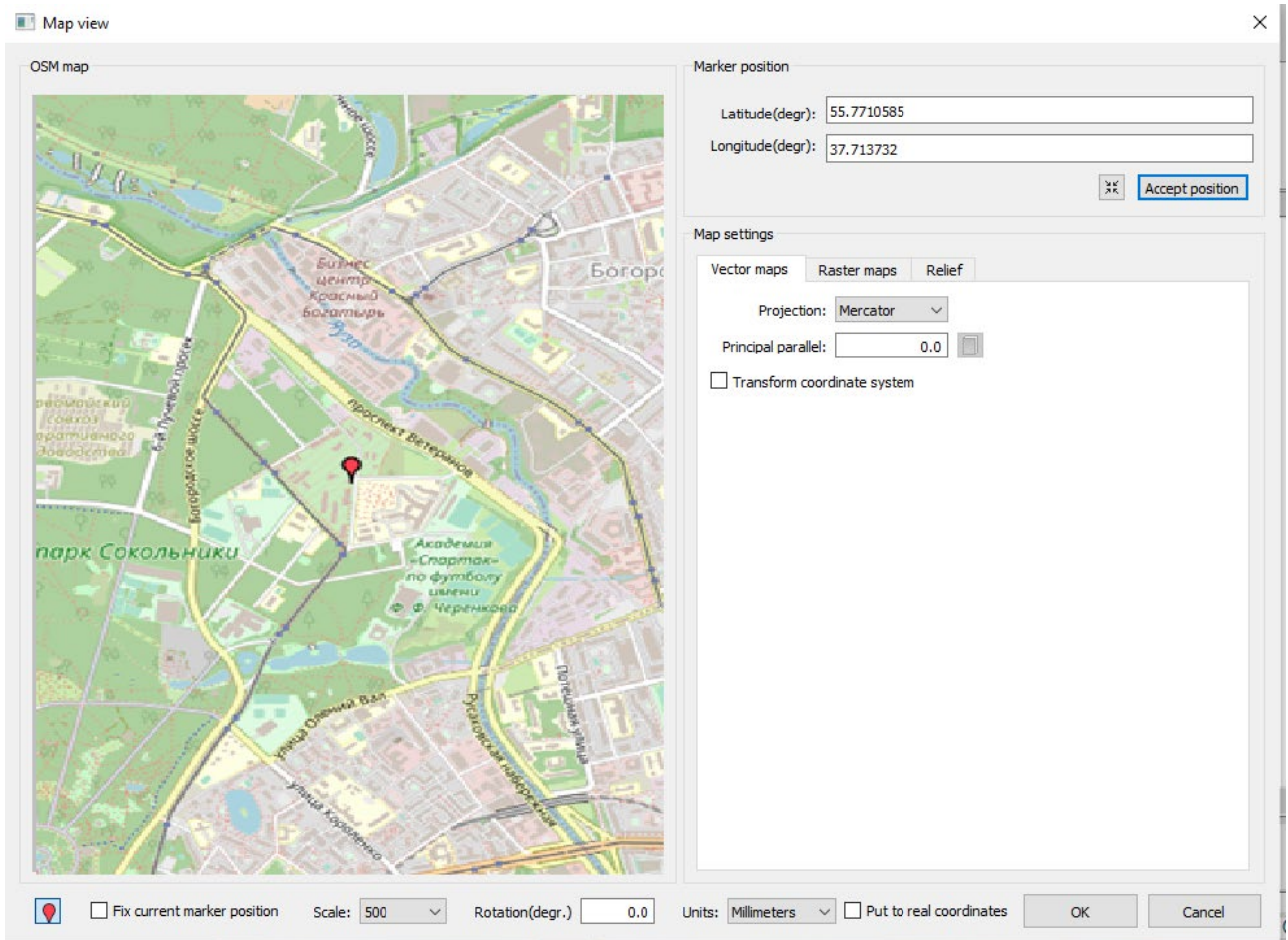

Set the required parameters in the dialog box that opens.

The dialog allows you to load three types of maps: vector, raster or relief maps. Each type of map is set on its own tab in the right part of the dialog box.

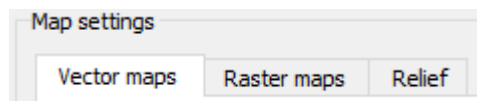

### Vector maps

The provider of vector maps is the **OpenStreetMap** service.

Go to the **Vector maps** tab.

In the representation window, select the desired area of import. The map is shifted with the left mouse button pressed, and scaled by rotating the wheel.

After selecting the desired area, the following settings are required at the bottom of the dialog box:

Fix current marker position    Scale: 500    Rotation(degr.): 0.0    Units: Meters

- Specify position of the marker relative to which insertion in the drawing will be made. To do this, press the button for setting the marker  at the bottom of the dialog box. It is fixed in the pressed state. After that the marker's position on the map is indicated by left double-click. In addition, the position can be specified by manually entering coordinates in the **Marker position** section.

Marker position

Latitude(degr): 55.7710585

Longitude(degr): 37.713732

- Checking the **Fix current marker position** box fixes the last set position for all windows.
- Set the map scale, rotation angle of the inserted fragment relative to the marker (positive angle indicates counterclockwise rotation) and drawing units.
- On the **Vector maps** tab, select the projection of map representation in the drawing from the drop-down list **Projection: Mercator, Gauss-Krueger** or **UTM**.

Map settings

Vector maps    Raster maps    Relief

Projection: Gauss-Kruege

Principal meridian: 39 

Transform coordinate system

- When selecting rectangular projections, specify the principal meridian of the zone. For the current marker position, the field is filled automatically, but you can select by the zone number from the corresponding dialog called by  button.

Gauss-Krueger principal meridians

	Zone	Meridian
5	05	027°E
6	06	033°E
7	07	039°E
8	08	045°E
9	09	051°E

- If it is necessary to recalculate coordinates from WGS84 ellipsoid, which represent the OSM service data, check the Transform coordinate system

box. Then select the target transformation ellipsoid from the ellipsoids library opened by  button.

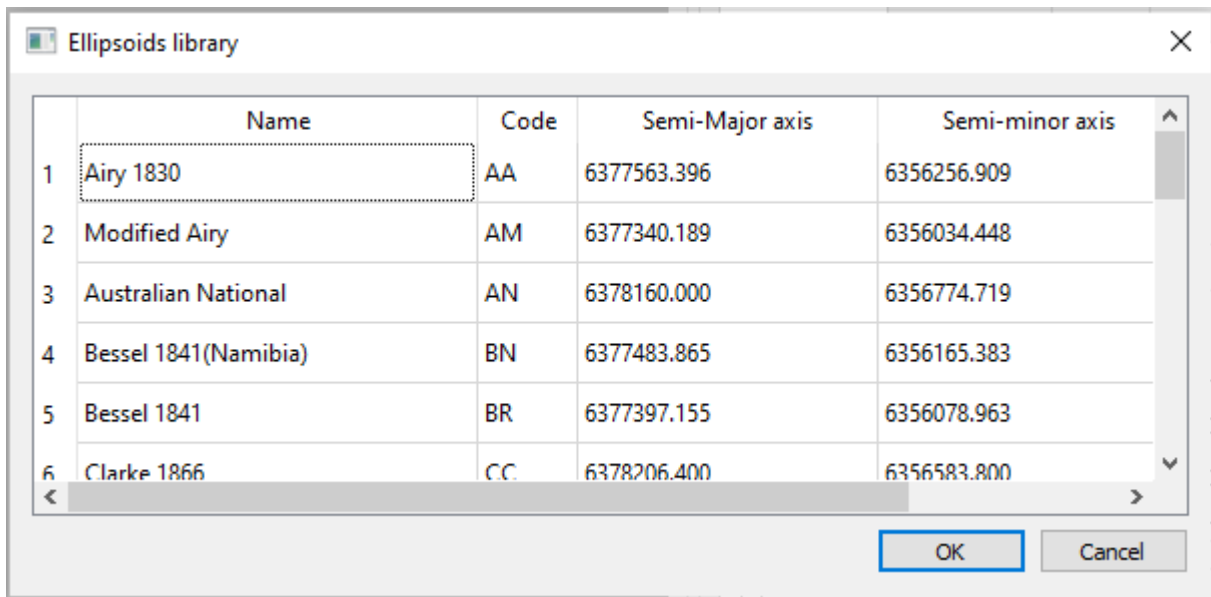

Fields of the **Target ellipsoid** section will be filled automatically:



- Then specify parameters of recalculation from WGS84 to the target ellipsoid. Seven-parameter Helmert transformation is used for recalculation. Upon calling the Helmert parameters dialog by  button, select the required set of parameters:

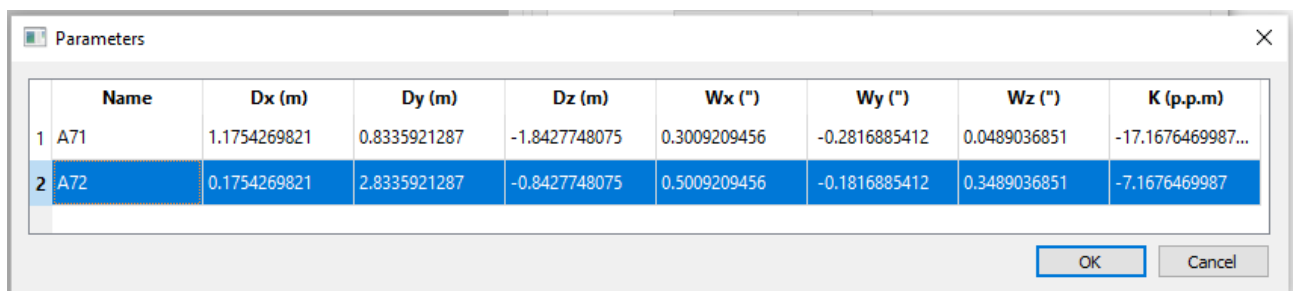

Fields of the **Transform parameters** section will be filled automatically:

Transform parameters

	Parameters	Value
1	Dx (m)	0.175
2	Dy (m)	2.834
3	Dz (m)	-0.843
4	Wx (")	0.5009209456
5	Wy (")	-0.1816885412

The transform parameters are selected from the file transform\_params.csv, which is located in the folder %nanocad%/UserDataCache/maplib/LIB and can be edited for adding new transformation parameters.

File fragment:

```
H7,A71,1.1754269821,0.8335921287,-1.8427748075,0.3009209456,
0.2816885412,0.0489036851,-17.1676469987
```

where:

- H7 – sign of transformation;
- A71- name (user identification);
- next three fields Dx, Dy, Dz – center offset relative to WGS84 center in meters;
- next three fields Wx, Wy, Wz – rotation of axes relative to WGS84 angular seconds;
- last field – scale factor in p.p.m. units (parts per million)- it is 1/1000000 from the factor's complement to one.

After setting all necessary properties, click the **Insert** button and specify the insertion point in the drawing. The marker position will be placed at this point.



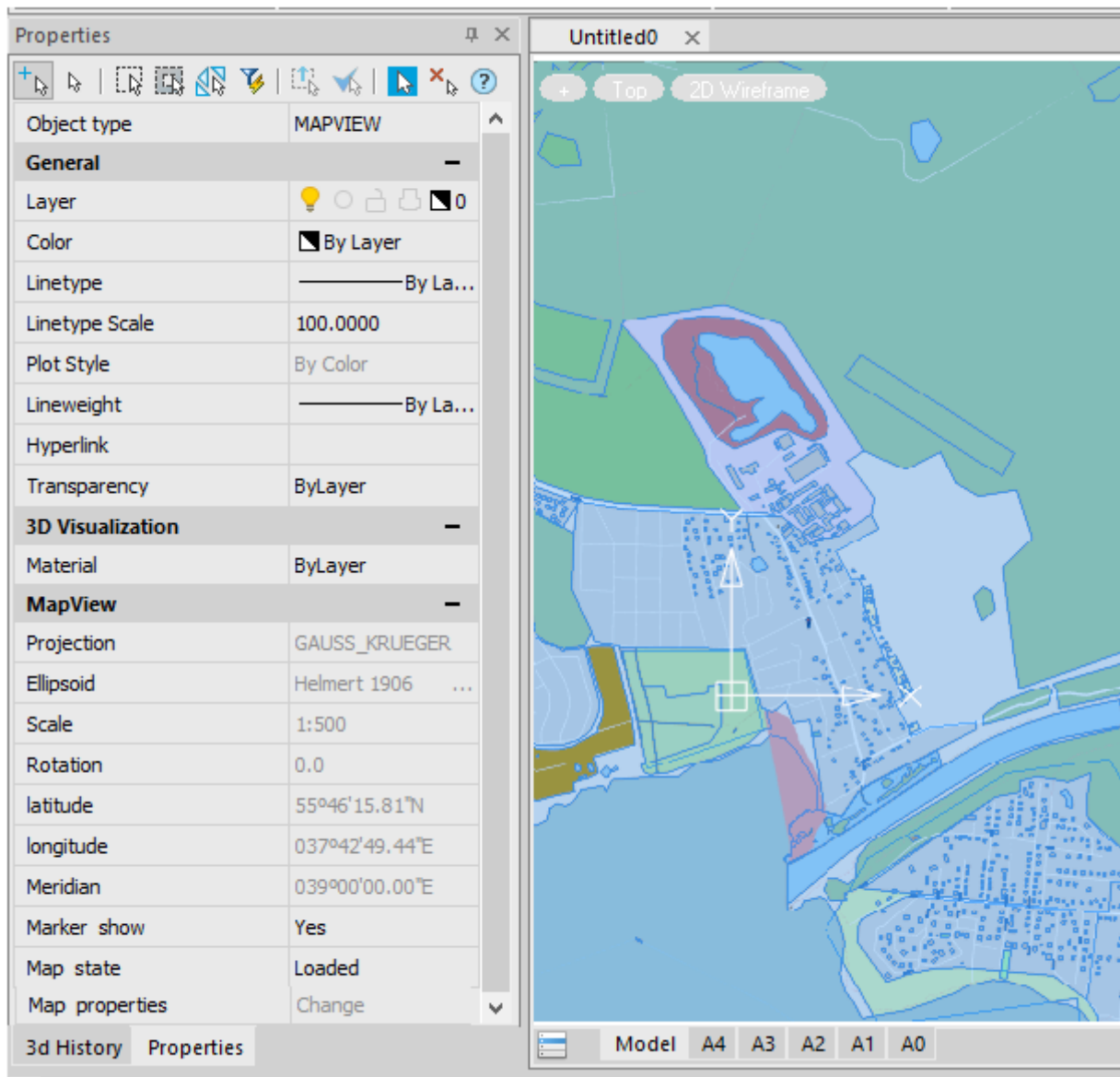

On the **Properties** toolbar, the following properties are displayed for vector map underlay: projection, ellipsoid, marker show, scale, rotation.

The marker display can be disabled (**Marker show** parameter).

Map underlays can be temporarily unloaded, if necessary (**Map state** parameter). In this case, only the outline of underlay will be displayed in the drawing, without its content. The UNMAPVIEW REMAPVIEW commands allow group operations of uploading and downloading map underlays.

For loaded vector maps, a choice of displayed layers is available. To do this, click the button to the right of **Map properties** item.

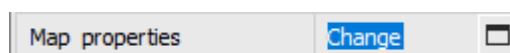

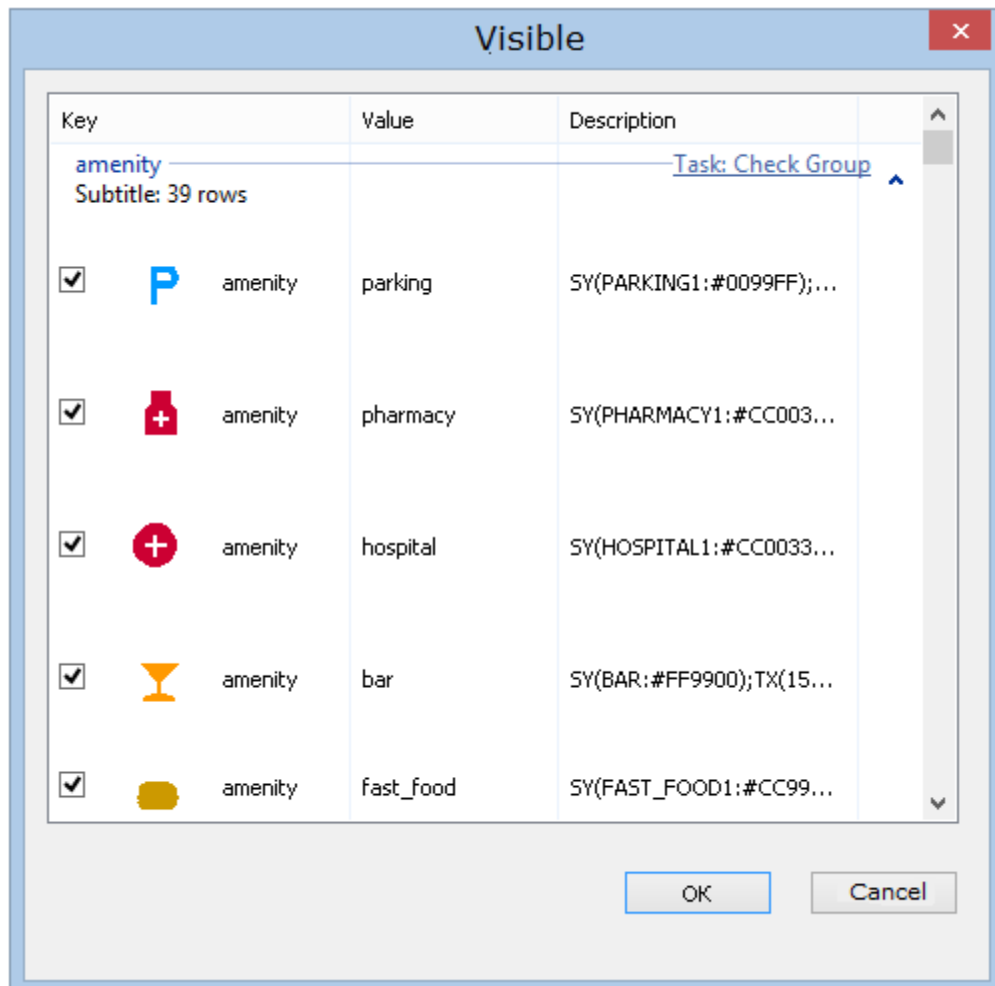

To disable a layer, clear a box. Names of displayed objects and instruction for their display are given in columns on the right. Object display settings files are located in the folder UserDataCache/maplib/styles

### Raster maps

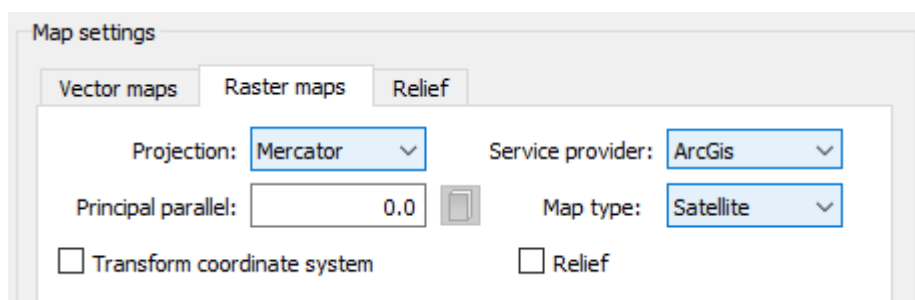

Providers of raster maps (**Provider** field) are several services: OpenStreetMaps, Google Maps, Yandex Maps, OSM Topo, MapBox, ArcGis, Bing.

In addition, some providers present different types of maps (**Map type** field): street maps, satellite, hybrid, terrain, topo.

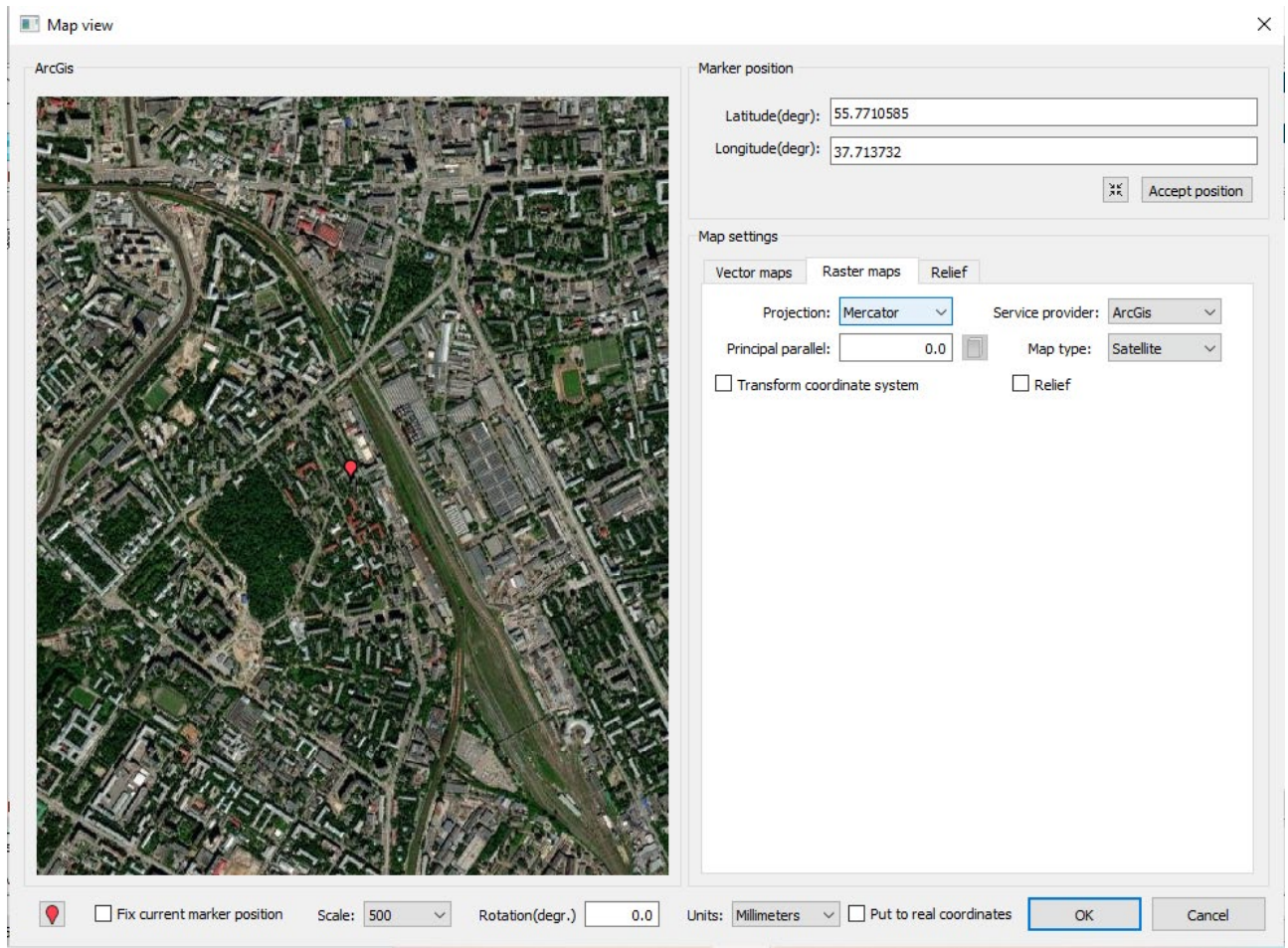



Import setting is similar to that of raster maps.

Additionally, for raster maps you can specify the **Relief** option, which allows you to add terrain height to the raster. An image becomes a texture stretched over a 3D terrain model.

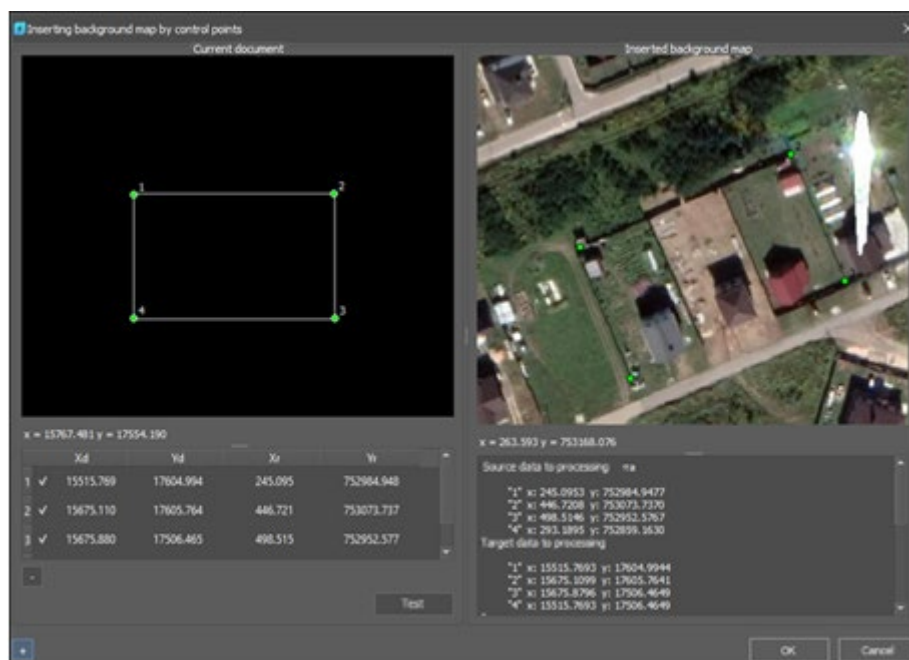
To insert raster cartographic underlays by control points, check the **By control points** box. After clicking the **OK** button, another dialog box will open, in which you will need to specify the source and resulting control pairs of points for which an attempt will be made to insert a raster map.



Stretch the preview areas of the current document (top left) and raster underlay (top right) if they are too small.

1. Click the plus  button.
2. Click in the left preview area of the current document to set the first target point.
3. Click in the right preview area of the raster underlay to mark the corresponding source point.
4. The coordinates of the first pair of points will appear in the left part of the dialog box.
5. Specify at least three more pairs of points. The points will change color from red to green.
6. To delete a pair of points, select it in the table and click the minus  button.
7. By clicking the **Test** button, you can see the conversion results and the maximum error. To exclude a pair of points from the calculation, it is not necessary to delete it, just uncheck the box next to it.
8. If the conversion result is satisfactory, click **OK**.

## Relief

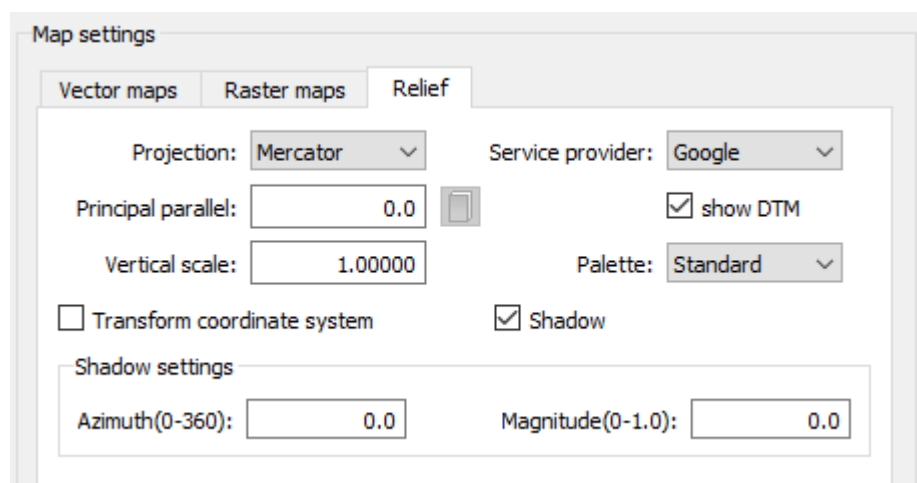

The **Relief** tab allows using 3D terrain model as an underlay.

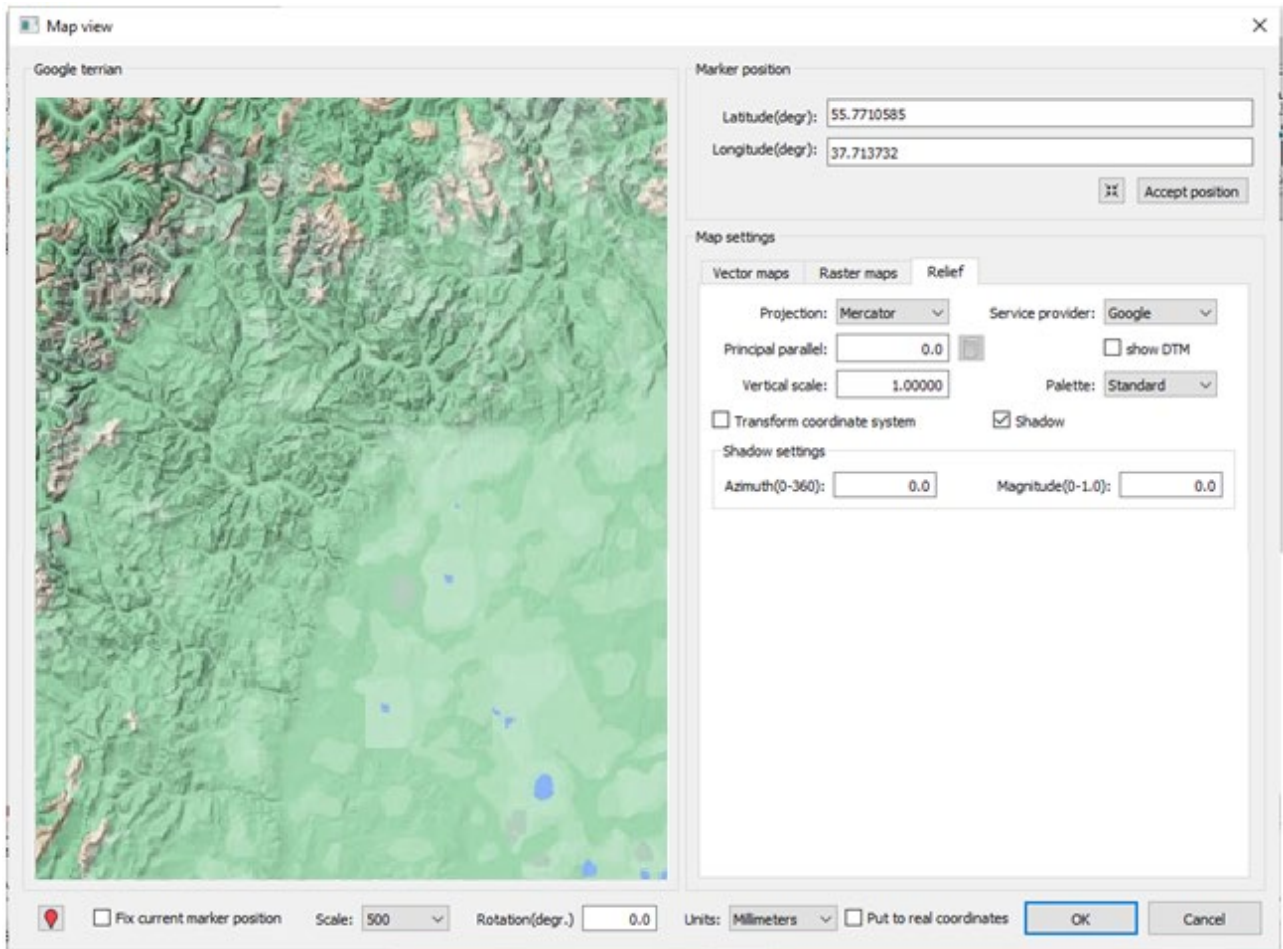

To select the area, relief raster images of Google or satellite images of MapBox are used. The model provider is MapBox service.

In addition to standard import settings, the following are available: vertical scale of relief, selection of height color palette, shadow.

The **show DTM** checkbox allows displaying actual DTM in the window when selecting MapBox provider.

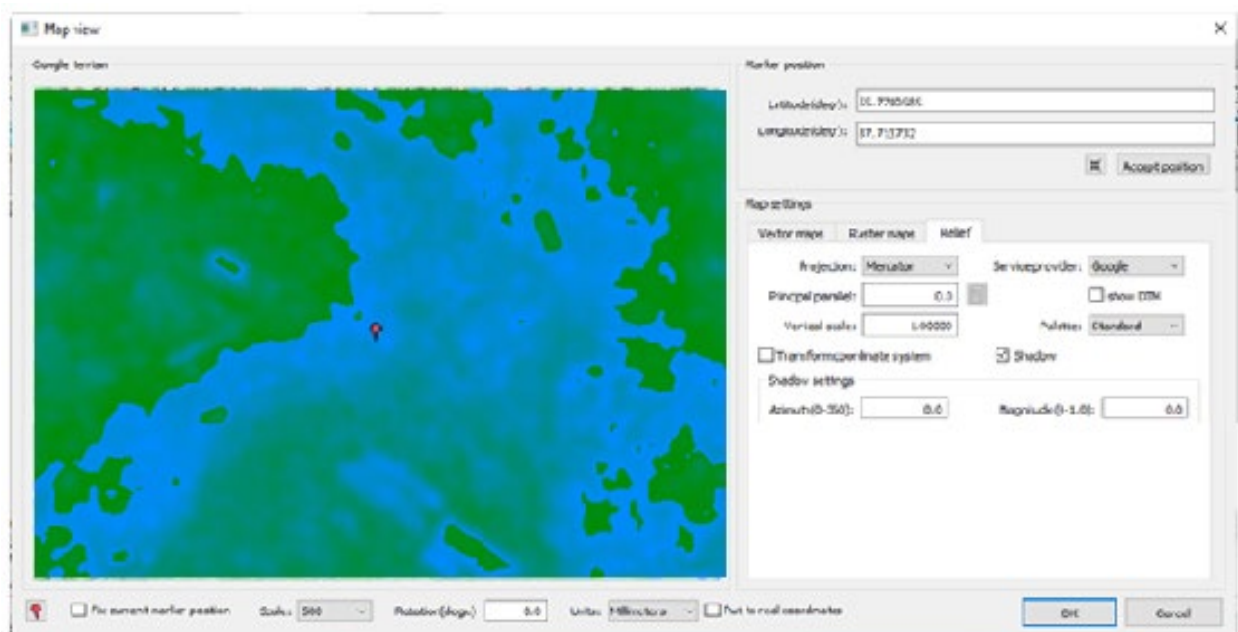



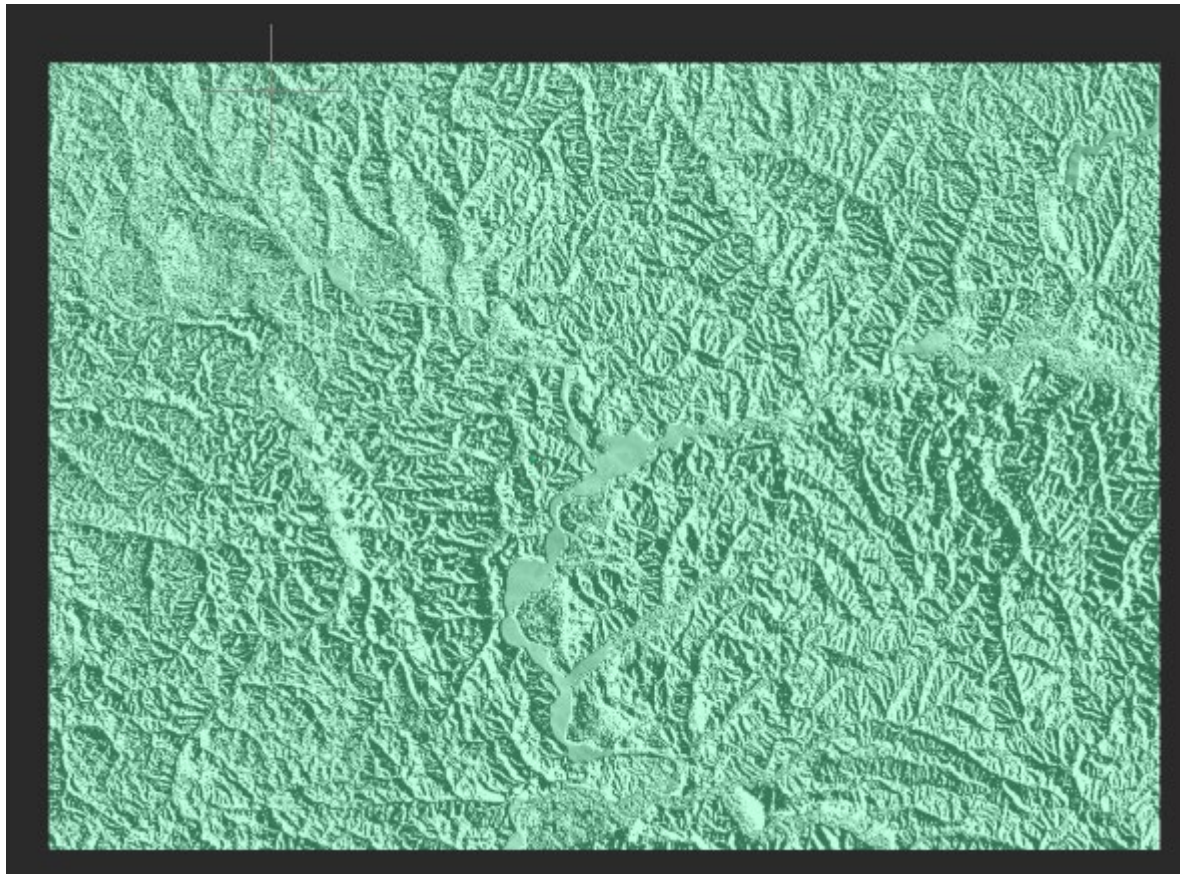

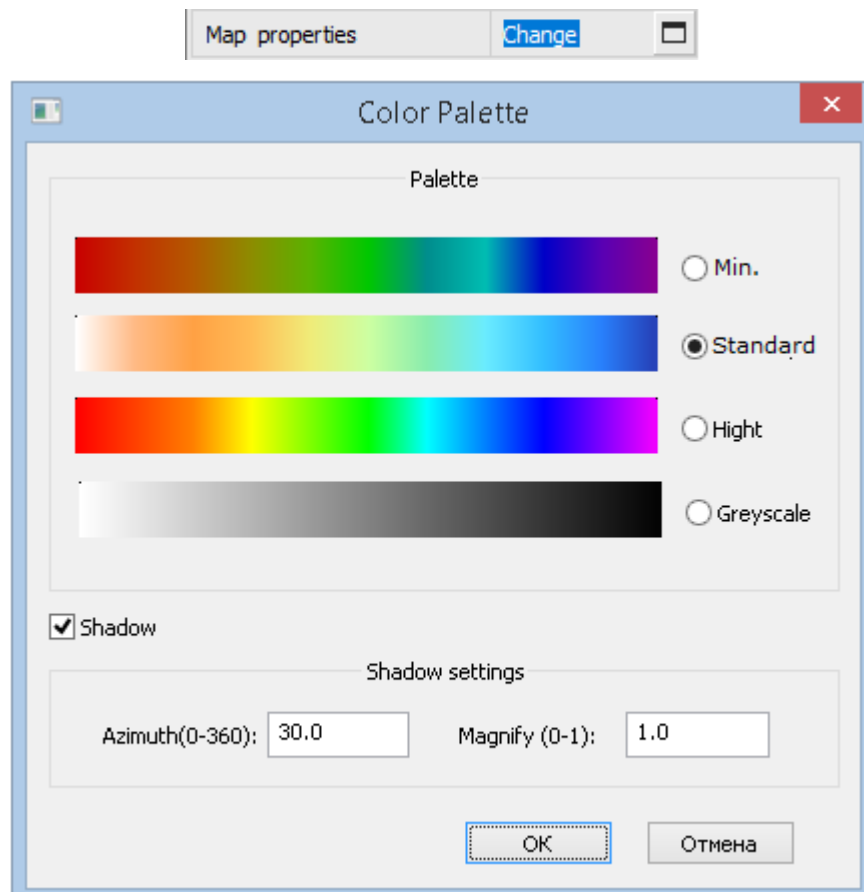

When selecting "Shadow" item, shadow parameters become available



For underlays of **Relief** type loaded in a drawing it is possible to change the relief parameters. To do this, click the button to the right of **Map properties** item.



## Clip Map Underlay

-  Ribbon: **Insert – Maps >**  **Clip Underlay**
-  Ribbon: **Topoplan – Maps >**  **Clip Underlay**
-  Menu: **Topoplan – Maps >**  **Crop Underlay**
-  Command line: **CLIPMAP**

Visibility of underlays can be partially limited by a clip contour.

After calling the command, you will need to specify the underlay to which the operation will be applied.

Further, points of the clip contour are specified in an interactive mode.









As a result of operation, a clip contour will be created, limiting the visibility of map underlay.

The contour can be edited using grips.

You can turn off the display of the vector border of the contour on the **Properties** toolbar (**Show clip** option).

## Unload Map Underlay

-  Ribbon: **Insert – Maps >**  **Unload Underlay**
-  Ribbon: **Topoplan – Maps >**  **Unload Underlay**
-  Menu: **Topoplan – Map >**  **Unload Underlay**
-  Command line: **UNMAPVIEW**

The command unloads the underlay content. Only the underlay contour is displayed.

You can load the underlay content back by the **Load Underlay** command.

The command works identically to the **Map State** underlay parameter on the **Properties** bar.

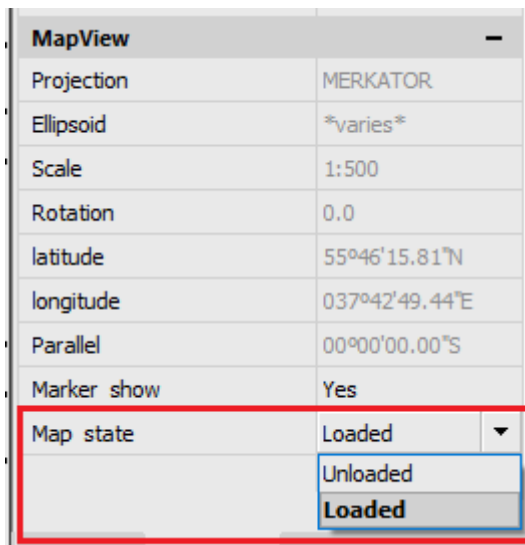

## Load Map Underlay



Ribbon: **Insert – Maps** >  **Load Underlay**



Ribbon: **Topoplan – Maps** >  **Load Underlay**



Menu: **Topoplan – Maps** >  **Load Underlay**



Command line: **REMAPVIEW**

The command allows you to load back the underlay content after unloading it by the **Unload Underlay** command. Only the outline is displayed for the unloaded underlay.

The command works identically to the **Map State** underlay parameter on the **Properties** bar.

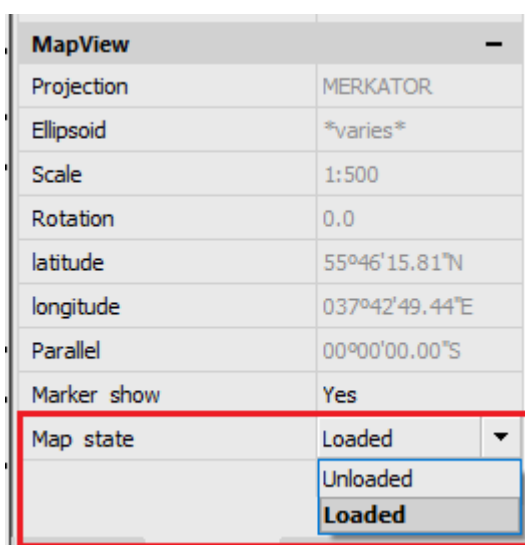



## Hyperlinks

Hyperlinks are the convenient tool to link graphical objects of the current document with others (drawings, specifications, etc.) and represent the references to related files. Hyperlinks can point to files located on your computer, a local network or the Internet as well as to named position in the current or linked document.

When you place the cursor over an object that is connected to a hyperlink, the hyperlink and tooltip will display:

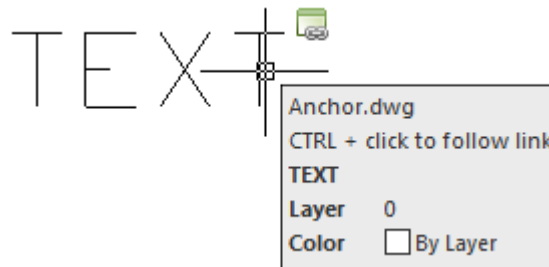

Left click on hyperlink with **CTRL** button pressed to go to the reference. If the named position was defined for the reference in the current drawing, for example, layout A3, it will be displayed (recreate) on the screen. If the file was defined for the reference, the corresponding editor (for example, MS Word for the text file or nanoCAD for \*.dwg) will be opened. The hyperlink to the web-page activates browser and switching it to the specified web site. In some cases it is useful when the hyperlink opened e-mail client to create the message in it.

Hyperlinks can be *absolute* and *relative*. *Absolute hyperlink* contains the full path to the file. *Relative hyperlink* contains only part of the path, measured from some URL or from the folder specified in the **HYPERLINKBASE** system variable.

## Add Hyperlinks to the Document



Ribbon: **Insert – Data** >  **Hyperlink**



Menu: **Insert – Hyperlink Edit ...**



Command line: **HYPERLINK**

The command allows you to select one or several objects in the document to add a hyperlink to them. After selecting objects and pressing **ENTER** to confirm the selection, the **Hyperlink** dialog box with the following tabs opens: **Existing file or Web page**, **View of This Drawing** and **E-mail address**.

The **Text to display** field at the top of the dialog box is common to all of tabs and is used to enter a hyperlink description in cases when the file name or address, to which reference is made, do not evidence of the contents of the file or address.

### The “Existing File or Web Page” Tab

The tab is used to create a hyperlink for an existing file or web page.

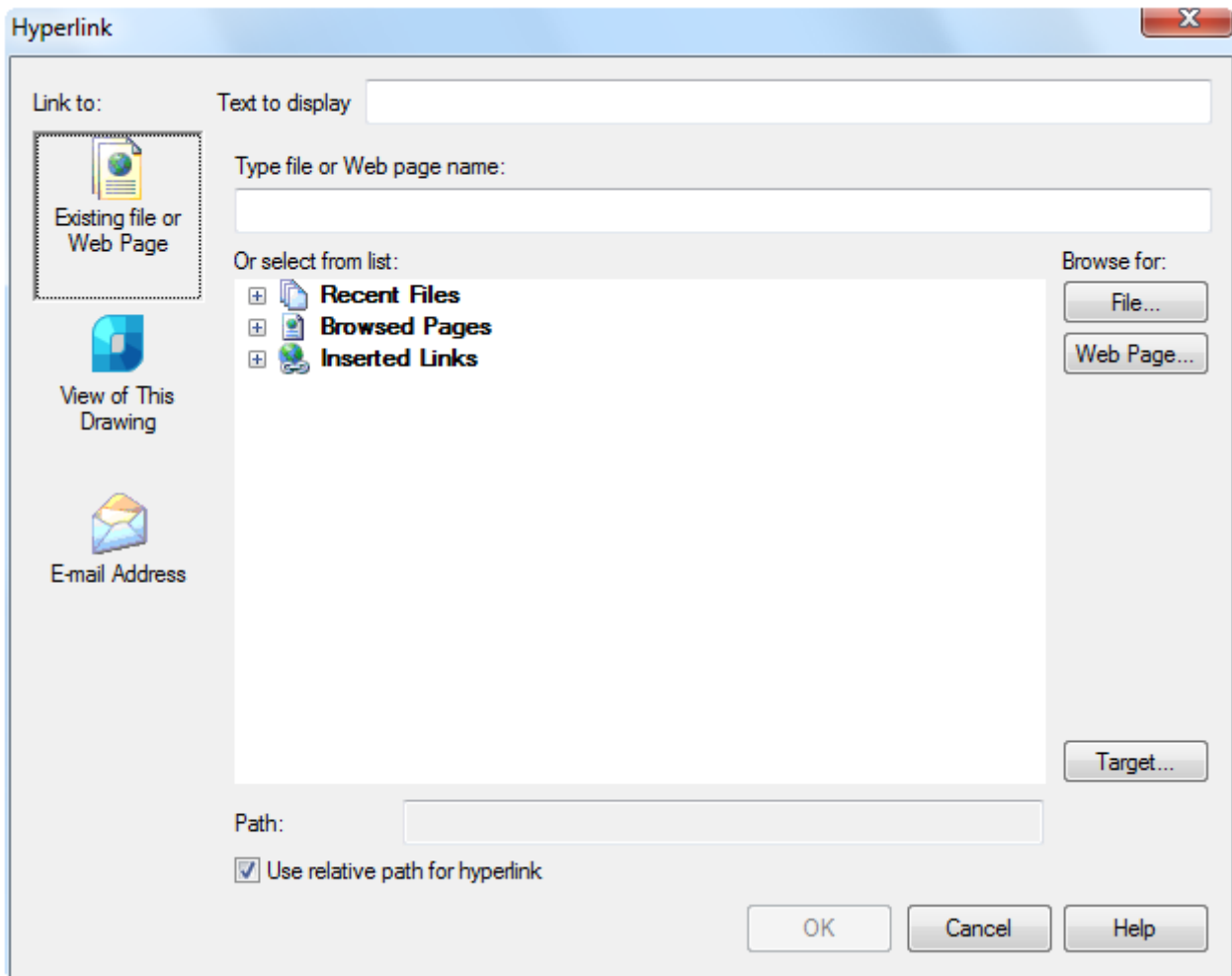

### Options:

*Type file or Web page name:*

Sets the file or web-page.

The file name or URL can be entered manually, inserted from the clipboard or automatically when you choose from the **Or select from list:** section.

*Or select from list:*

The drop-down list to select the recent files, recently browsed pages and the recent inserted hyperlinks.

**Recent Files**

The drop-down list of recently used files.

**Browsed Pages**

The drop-down list of recently browsed pages.

**Inserted Links**

The drop-down list of recently inserted hyperlinks.

*Browse for:*



The button calls the standard file selection dialog box, where it is possible to find the file, on which you create a hyperlink.

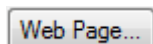

The button calls the browser to access the web-page for which it is necessary to set a hyperlink.

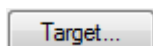

The button calls the **Select Place in Document** dialog box to specify a named position in the document on which the hyperlink is created.

*Path:*

The field displays the file path for the hyperlink.

When the **Use relative path for hyperlink** option is on, the file name only displays.

When the **Use relative path for hyperlink** option is off, the full path to the file displays.

**Use relative path for hyperlink**

Turns on/off the use of a relative path for hyperlinks.

When the option is on, a relative patch to the related file is stored in the hyperlink. The value specified by the **HYPERLINKBASE** system variable is set for the relative path. If this variable is not set a value (by default), the relative path is defined as the path to the current drawing.

When the option is off, the full path to the related file is stored in the hyperlink.

## The “View of This Drawing” Tab

The tab is used to create a hyperlink to a named position in the current file or a file for which it is created.

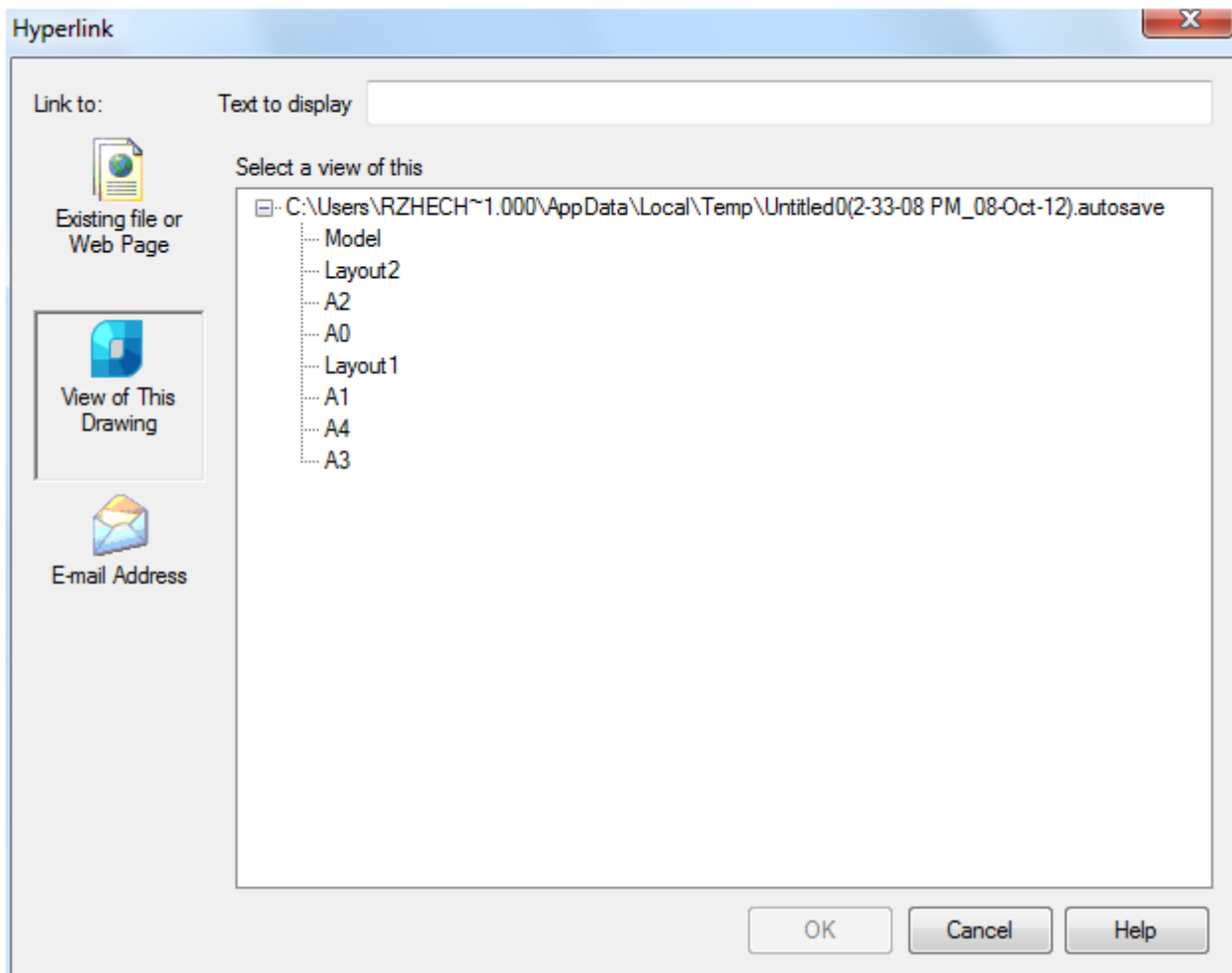

**Option:**

*Select a view of this:*

Selects a named position in the current drawing for which a hyperlink is created.

## The “E-mail Address” Tab

The tab is used to specify an e-mail address of created hyperlink. When you select a hyperlink in the document, the registered by default e-mail client in which you create new message opens.

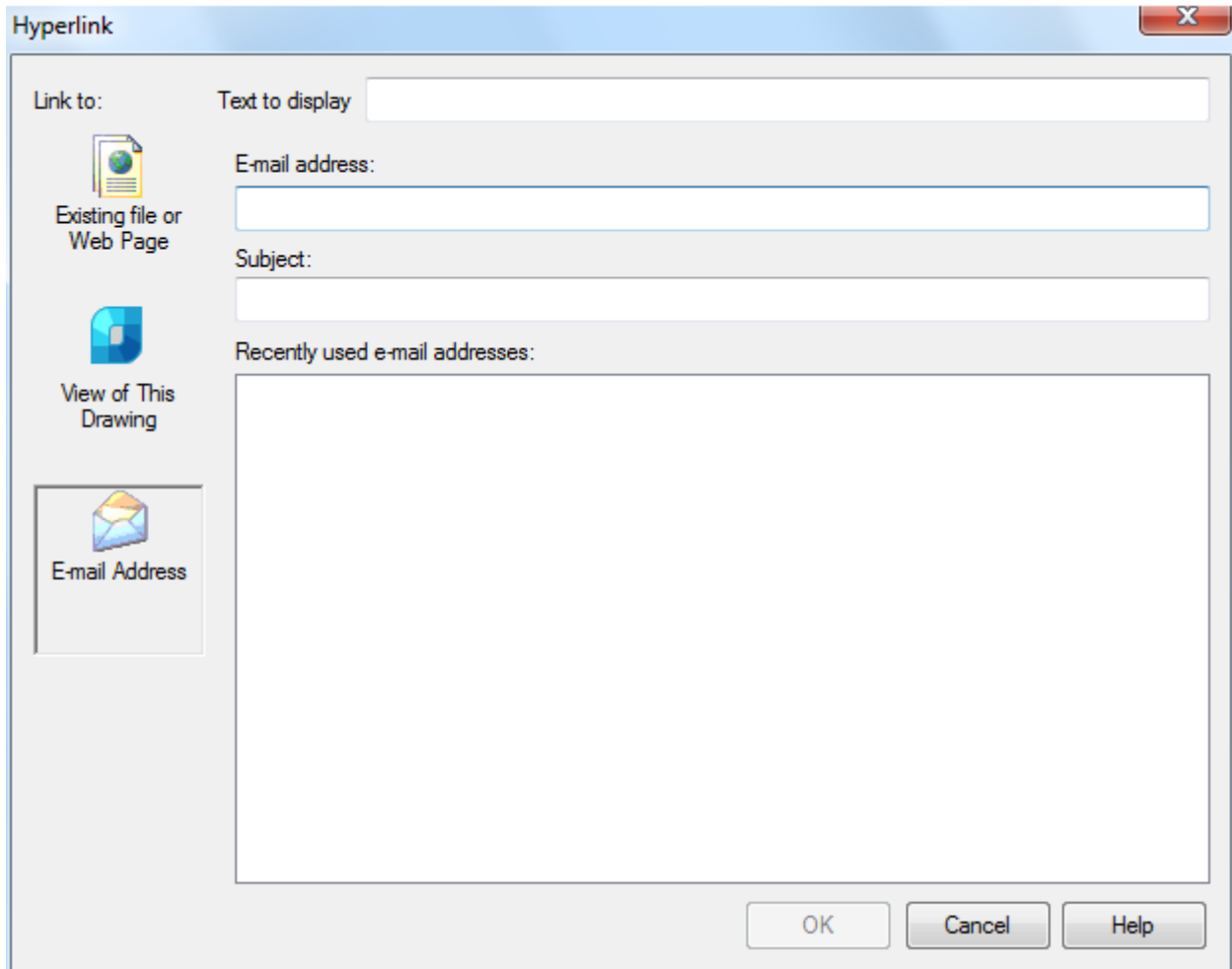

**Options:**

- E-mail address:** Enter an e-mail address.
- Subject:** Enter a subject.
- Recently used e-mail addresses:** The list of recently used e-mail addresses.

## Edit Hyperlinks



Menu: **Insert – Hyperlink Edit...**



Command line: **HYPERLINK**

To edit hyperlinks you should use a slightly different **Hyperlink** dialog box. It is different from the dialog box used when you add a link in only one additional option – **Remove link** button.

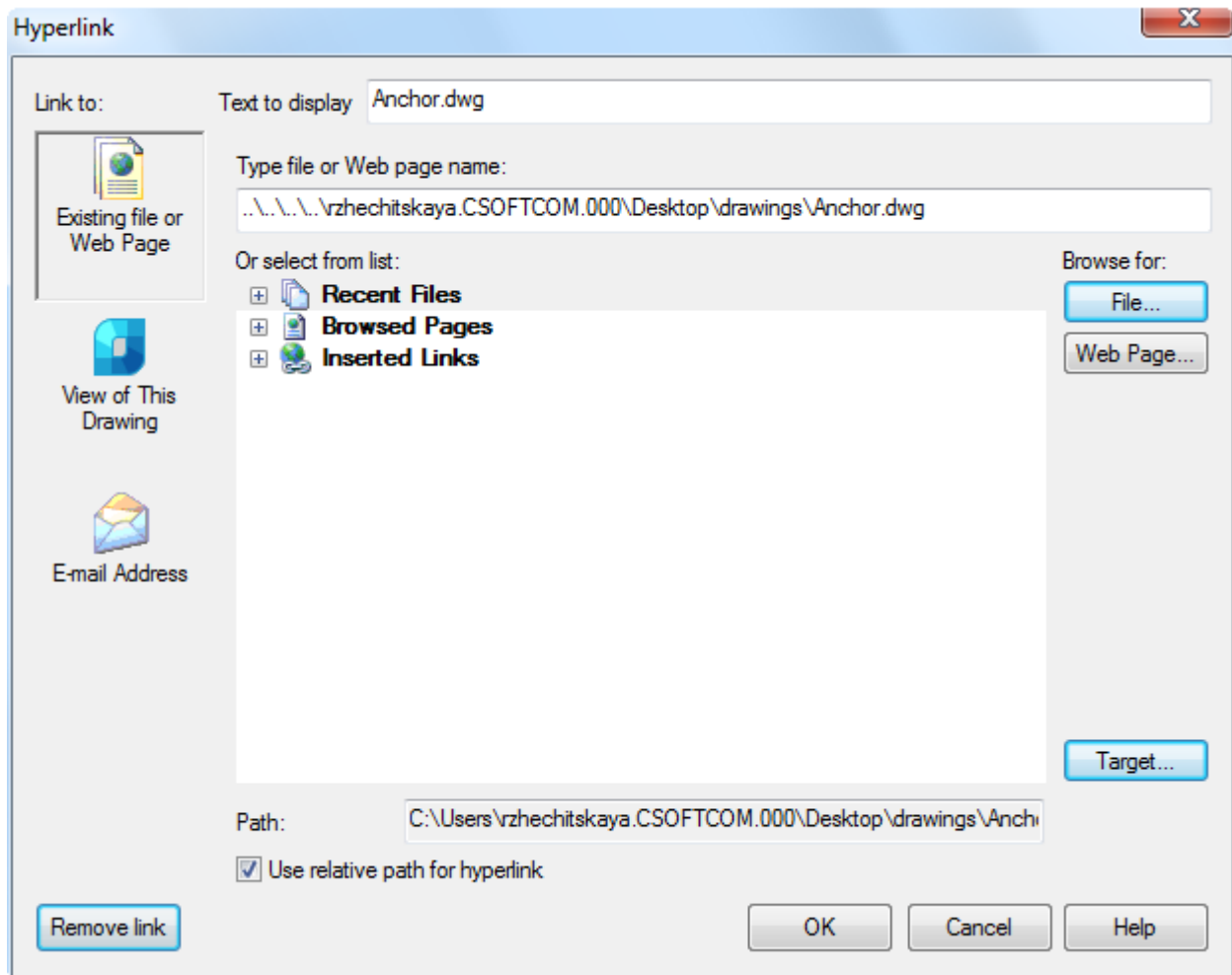

**Option:**

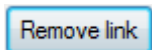

Removes a hyperlink from the selected objects.

Description of other options you can see in the «Add hyperlinks to the document» section.

## WORKING WITH RASTER IMAGES

nanoCAD contains tools for creating and editing of raster images.

According to used tool you can edit monochrome, color and/or grayscale images saved in internal or external format (TIFF, BMP, JPG, JPEG, PNG, PCX, GIF).

Most of the functionality of professional raster image processing (elimination of geometric distortions, alignment, calibration, automatic and semi-automatic vectorization, text recognition, color correction and color raster filters) is available in the **Raster** module. Description of the module commands is marked with the phrase:



This functional is available only in the Raster module.

The **Raster** module provides an extended set of raster image editing functions:

- Calibration of raster images to eliminate complex distortions in geometry;
- An extended set of raster selection methods with support for intelligent geometry recognition;
- Changing the size and resolution of an image;
- Filtering monochrome and color images using various algorithms to eliminate noise and improve the raster quality;
- Binarization and adaptive binarization for layer-by-layer separation depending on the established criteria;
- Automatic search and selection of text areas and linear objects on a raster.

It also contains a powerful functionality for converting a raster to a vector representation and vice versa:

- Automatic vectorization with text recognition;
- Semi-automatic vectorization (tracing) of polylines, contours, hatches and basic geometric entities;
- Various tracing modes, including intelligent deletion from the raster;
- Rasterization of vector objects.

### Insert Raster Image



Ribbon: **Raster – File** >  **Insert Image**



Ribbon: **Insert– Reference** >  **Insert Image**



Menu: **Insert** –  **Image from file...**



Menu: **Raster** –  **Image from file...**



Toolbar: **Draw** – 



Command line: **IAT, IMAGEATTACH, ROPEN, INSERTRASTER**

You can insert images into the drawing. The list of supported raster formats is displayed in the Raster file formats section of the **Options** dialog box (the **Tools** menu – **Options**):

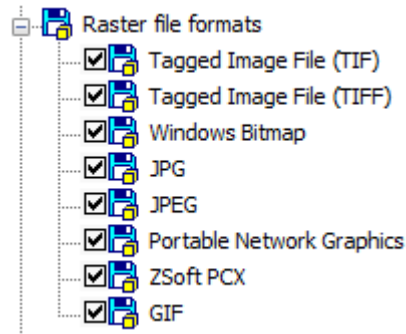

Raster images can be referenced and placed in drawing files but, like external references, they are not actually part of the drawing file. The image is linked to the drawing file through a path name. Linked image paths can be changed or removed at any time.

Once you've attached an image, you can reattach it multiple times, treating it as if it were a block. Each insertion has its own clip boundary and its own settings for brightness, contrast, fade, and transparency.

You can insert in the drawing a number of raster image files with the same name but different content. In such a case, a sequence number will automatically be added to the names of such images via an underscore sign "\_" starting with 1.

To insert a raster image, specify the necessary options in the opened **Insert Raster Image** dialog box.

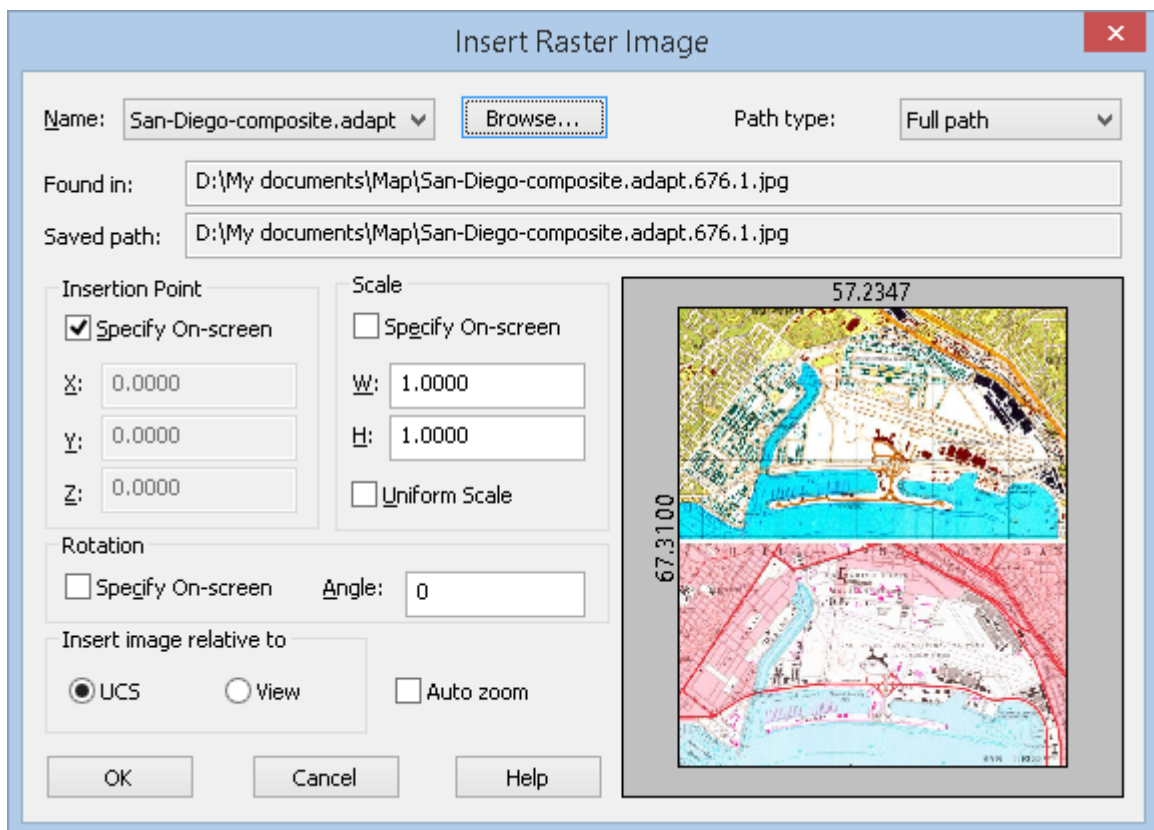

**Parameters:**

**Name:** Includes the list of names of the inserted images.

**Browse...** Opens the **Insert Raster Image** dialog box.

**Path type:** Sets the way to describe the location of the source file for the raster image insertion. Dropdown list contains several variants:

- Full path (absolute);

- Relative path;
- No path.

For more information on specifying a path, see the [Insert External Reference](#) section.

### *Insert Point*

**Specify On-screen** Selects the box to set the X,Y,Z coordinates values in the command line or specify the position on the screen. The «X» «Y» «Z» fields of this section are inaccessible.

**X: Y: Z:** Enters the X, Y, Z coordinate values for the raster image insertion in the corresponding fields.

### *Scale*

**Specify On-screen** Selects the box to set the scale value of the raster image in the command line or specify the position on the screen. The «X» «Y» «Z» fields of this section are inaccessible.

**W:** Sets the scale factor width.

**H:** Sets the scale factor height.

**Uniform Scale** Specifies the scale factor for the Width or Height values. A value specified for Width is also reflected in the Height value.

### *Rotation*

**Specify On-screen** Specifies the rotation angle for the inserted image, using the pointing device.

**Angle:** Sets the rotation angle for the inserted image.

### *Insert image relative to*

**UCS** Sets the insert image mode relative to the User Coordinate System (UCS).

**View** Sets the insert image mode relative to the World Coordinate System (WCS)

**Auto zoom** Switches on/off the full screen mode of the inserted reference.

To insert georeferenced raster image, check **Use World of TAF file** in **Options** dialog.



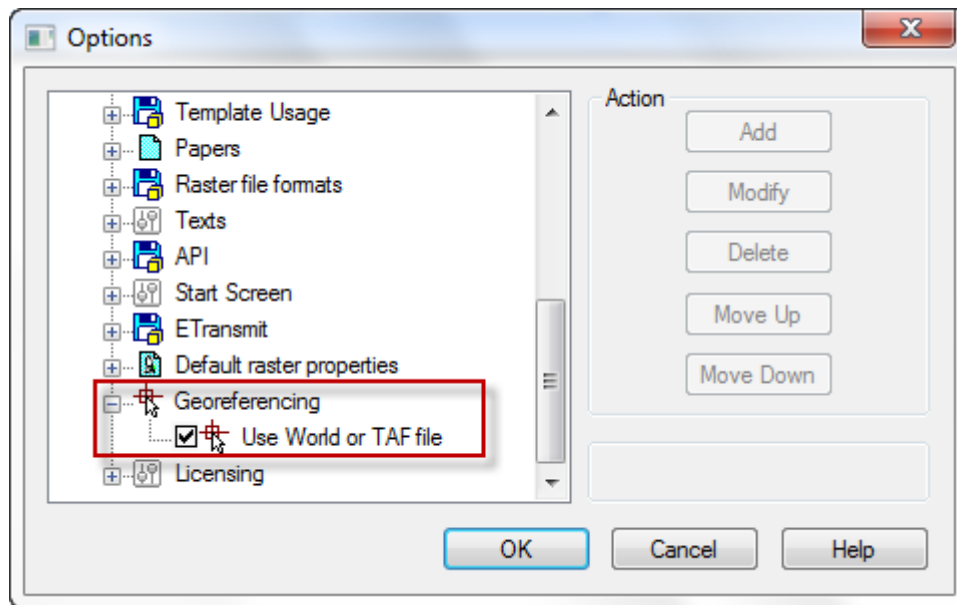

When inserting raster images with geodata, the coordinates of the insertion point, scale and rotation angle are automatically substituted in the **Insert Raster Image** dialog box.

## Create New Image and Rasterize Objects

### New Image from Selection



Ribbon: **Raster – File** >  **New Image from selection**



Menu: **Raster –**  **New Image from Selection**



Toolbar: **Raster –** 



Command line: **NEWRASTERFROMSELECTION**

Selection for new image can contains:

- raster images;
- vector objects.

When there is no selection, the operation will apply to all data in the current workspace.

When you select vector data, they are rasterized. Color of rasterized objects depends on color of the resulting raster image:

- **Monochrome images** - rasterized objects will have color of monochrome image.
- **Color Image** - rasterized objects will have original color.

#### How to create new image from selection

1. Select objects and run **New Image from Selection** command;
2. Set options in **New Image from Selection** dialog.

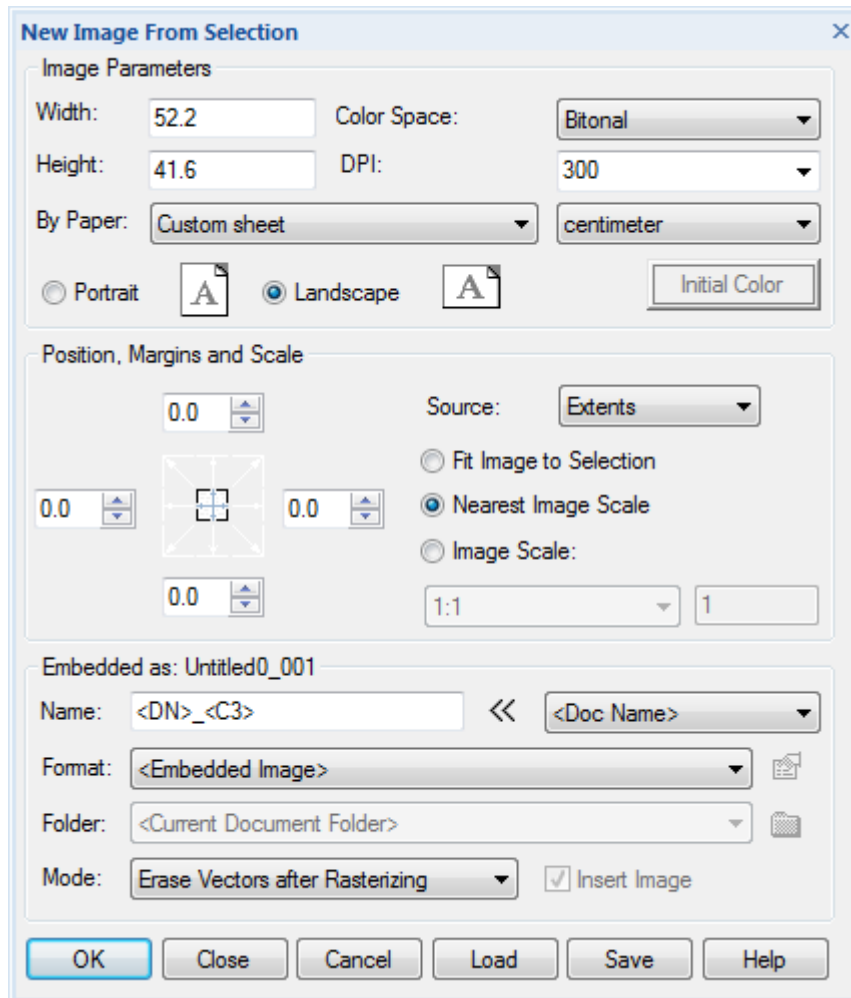

3. Click **OK**.

### New Image from Selected dialog settings:

#### Image Parameters

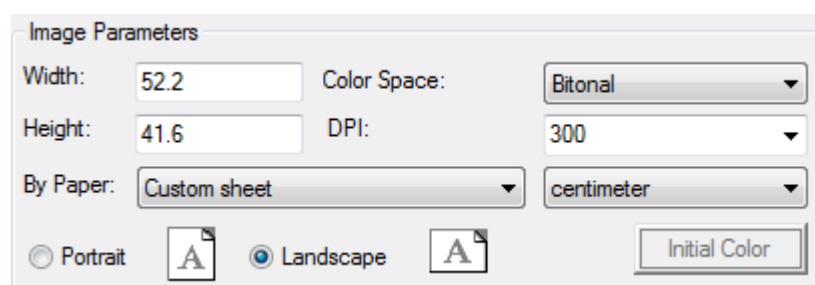

Option	Description
<b>Width Height</b>	Specify width and height for the new image.
<b>By Paper</b>	Select from the list of standard paper sizes.
<b>Color Space:</b>	Specify color space – monochrome, grayscale, indexed or TrueColor. By default, the type with the highest color depth is suggested. If you have monochrome and color raster data, set the type to match the color raster.
<b>DPI</b>	Set resolution in DPI (dots per inch).
<b>Portrait</b>	Select orientation.

<b>Landscape</b>	
<b>Initial color</b>	Choose background color for color images.

If your selection contains raster images it's better to set **Resolution** and **Color Space** not lower than best raster image to avoid quality reduction. For example, if you have raster grayscale raster image with 300 dpi, you should set **Grayscale** or **TrueColor**, and **Resolution not lower** than 300 dpi.

*Source*

Select objects/area for rasterization:

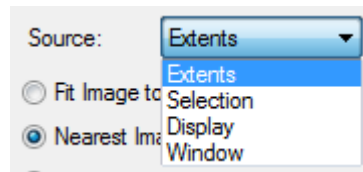

Option	Description
<b>Extents</b>	Rasterizes all objects in the drawing's current space.
<b>Selection</b>	Rasterizes preselected objects.
<b>Display</b>	Rasterizes the current view of the graphic area.
<b>Window</b>	Selection of rasterized area with a rectangular. The area request is initiated immediately after selecting the <b>Window</b> option from the drop-down list. To redefine the rasterization area, use  button.

*Position, Margins and Scale*

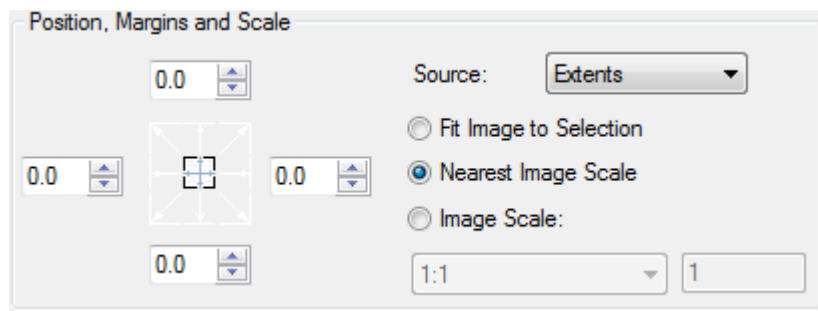



The image scale is set by selecting the desired position:

Option	Description
<b>Fit Image to Selection</b>	Select scale to fit all objects to single image.
<b>Nearest Image Scale</b>	Select nearest standard scale to fit all objects to single image.
<b>Image Scale</b>	Set scale manually or from list

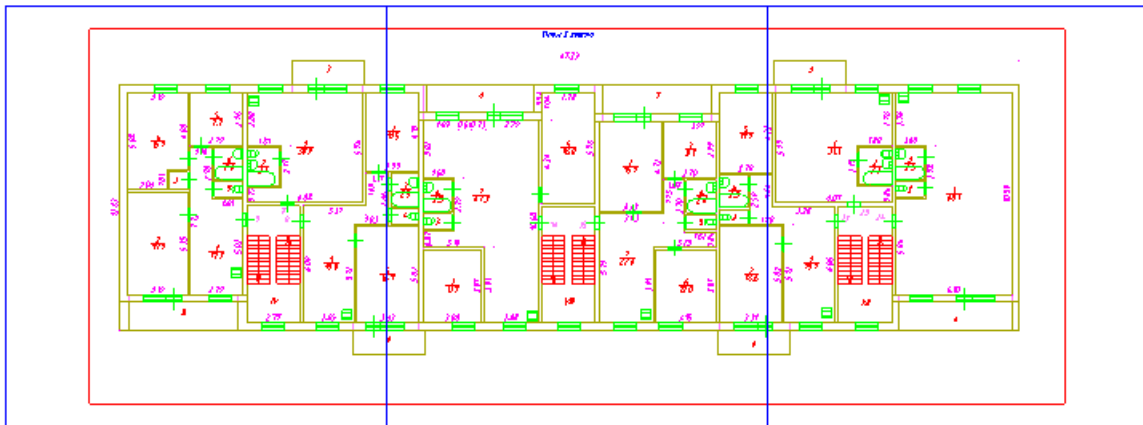
Using Image Scale, you can create more than one image with specified scale.



In this case files will be created with order number. In this case, the results will be saved to separate files with adding page numbers to the set name:

-  4Floor\_plan\_1\_001.tif
-  4Floor\_plan\_1\_002.tif
-  4Floor\_plan\_1\_003.tif

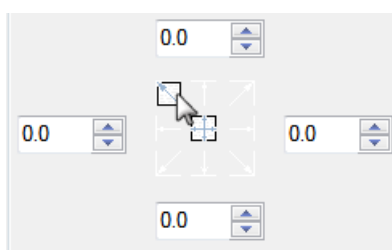



Set margins and image position. Positions the image relative to the sides of the fixed aspect. Enter indentation values in the section fields corresponding to the image sides. If the image fits into one page of the current format, you can set alignment to one of the sides by left-click on the arrow with the desired alignment type

*Embed or save as*

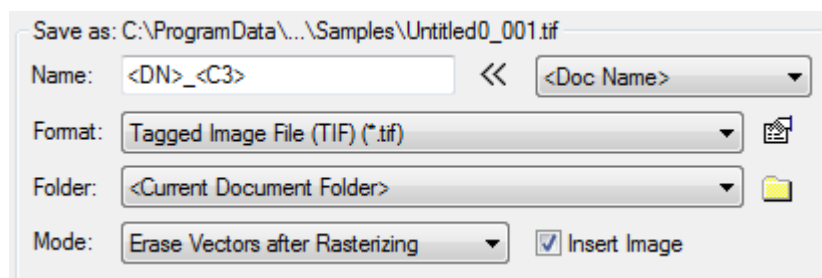
Settings for saving the resulting image.



Option	Description
<b>Name</b>	<p>Specify name for the image It can be done manually or using macros. When naming, you can use the macro definition in the name mask, either by entering it manually or by selecting a value from the list in the right field:</p> <ul style="list-style-type: none"> <li>• Select variable, press  button.</li> </ul> <p>Macro definitions from the list are always added to the end of the mask (but you can transfer them manually). When naming, they are replaced with their corresponding value.</p> <p>A sample full name is displayed at the top of the section.</p>

<b>Format</b>	Select format for raster file: Embedded TIF, TIFF, BMP, JPG, JPEG, PNG, PCX, GIF. For some formats, additional options are available by  button.
<b>Folder</b>	Specify folder for raster image file. If <b>Current document folder</b> is selected – image will be saved to the same folder where drawing is stored. This option is unavailable, if the <b>&lt;Embedded Image&gt;</b> value was selected in the <b>Format</b> drop-down list.
<b>Mode</b>	Action with selected object after rasterization: <ul style="list-style-type: none"> <li>• <b>Keep Vectors after Rasterizing;</b></li> <li>• <b>Erase Vectors after Rasterizing.</b></li> </ul>
<b>Insert Image</b>	Checking this box allows you to immediately insert the created raster image saved in a separate file into the original document. If the checkbox is not checked, only the raster image is saved to the specified folder, without inserting a link to it. The checkbox is unavailable if the <b>&lt;Embedded Image&gt;</b> value was selected in the <b>Format</b> drop-down list

### Finish your work

Buttons.





Button	Function
<b>OK</b>	Creates raster image. All dialog settings will be saved.
<b>Close</b>	Closes the dialog with saving all dialog settings. Raster will be not created.
<b>Cancel</b>	Closes dialog without changes.
<b>Load</b>	Loads the dialog settings from the template file <b>.tpl</b> .
<b>Save</b>	Saves the dialog settings to template file <b>.tpl</b> .
<b>Help</b>	Opens Help.

## Save Objects to a File

 Ribbon: **Raster – File >**  **Save as Image**

 Menu: **Raster >**  **Save Objects to a File**

 Toolbar: **Raster –** 

 Command line: **RASTEROUT**

The command exports part of drawing to graphic format.

After start you will see prompt with a list of selectable options in the command line.

When the command runs in Model space:

Specify area to rasterize <Screen> or [Screen/Extents/Window]:

When the command runs in Layout:

Specify area to rasterize <Screen> or [Screen/Layout/Window]:

**Options:**

- Screen Exports the current view of the screen into graphic format.
- Window Selects export area by frame.
  - Specify first window corner: - Specify the first corner of rectangle frame.
  - Specify second window corner: - Specify opposite corner of rectangle frame.
- Extents Exports of all objects. Option is displayed when the command runs in Model space.
- Layout Exports of all layout contents. Option is displayed when the command runs in Layout.

**Further command prompts:**

Input file folder <C:\ProgramData\Nanosoft AS\nanoCAD Int 24.0\Samples> or [Browse]:

Press **ENTER** to save the file in the previous path, or browse the path in dialog by selecting option Browse.

Input file name <Untitled0\_Layout1>:

Press **ENTER** to save the file under the previous name or enter new name.

Choose file type <EMF> or [EMF/WMF/TIF/TIFF/BMP/JPG/JPEG/PNG/PCX]:

Press **ENTER** to save the file in the previous format or enter other format.

Specify DPI <300> or [75/150/200/300/400/600/1000/1200]:

Press **ENTER** to save the file in the previous format or enter other format.

## Save Screenshot to a File

 Ribbon: **Raster – File >**  **Save screenshot as to file**

 Menu: **Raster –**  **Save Screenshot to a File**

 Toolbar: **Raster –** 

 Command line: **RASTERPRINTSCREEN**

Save the current view of workspace to EMF-file.

1. Run **Save Screenshot to a File** command.
2. Specify the path for file.
3. Click **OK**.

Screenshot saves to specified folder with the name of drawing file at the first time and nameN, N – is the number of saved file:

**Untitled0.EMF**



**Untitled0\_1.EMF**

**Untitled0\_2.EMF** etc.

## Create New Raster Image

 Ribbon: **Raster – File >**  **New Image**

 Menu: **Raster –**  **New Image**

 Toolbars: **Raster –** 

 Command line: **NEWRASTER**

Create new (empty) raster image and insert it to current document.

1. Run **New Image** command.
2. In **New Image** dialog set desired options.
3. Click **OK**.
4. Specify insertion point.

**New Image** dialog options

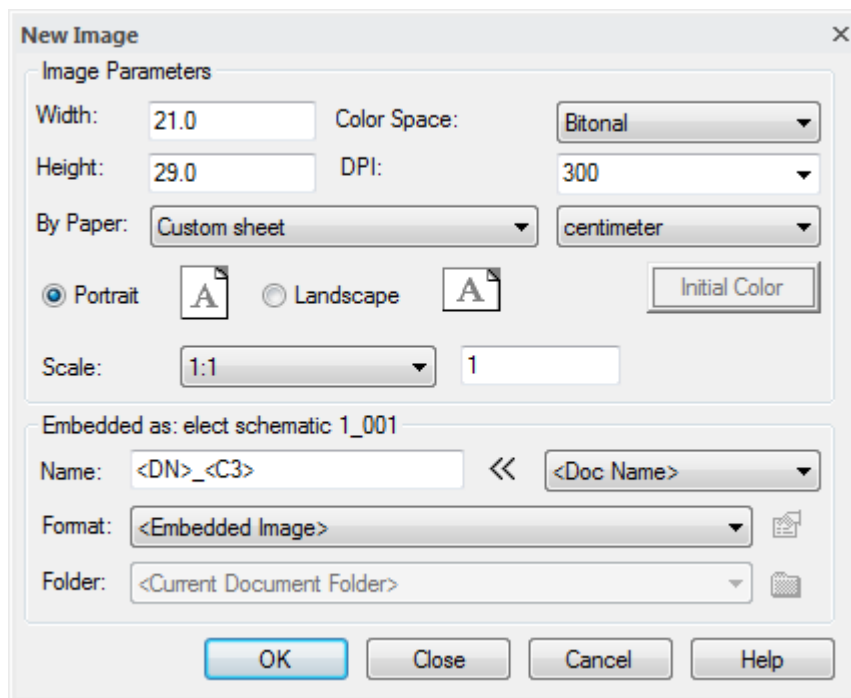

See the [New Image from Selection](#) command for options details.

## Separate Raster Image

 Ribbon: **Raster – Settings >**  **Separate raster**

 Menu: **Raster –**  **Separate raster**

 Toolbar: **Raster –**  **Separate raster**

 Command line: **SEPARATERASTER**

You can separate raster images from original reference and assign new name and path, if raster image was inserted to drawing more than once or its copies were created in a session.

1. Run command **Separate raster**.
2. Select raster images to create separate references to files.
3. Press **ENTER**.

Separated raster images marked in **External references** dialog by adding *\_clone\_N* to the name, *N* – ordinal number of copy, and by status – *Not Found*.

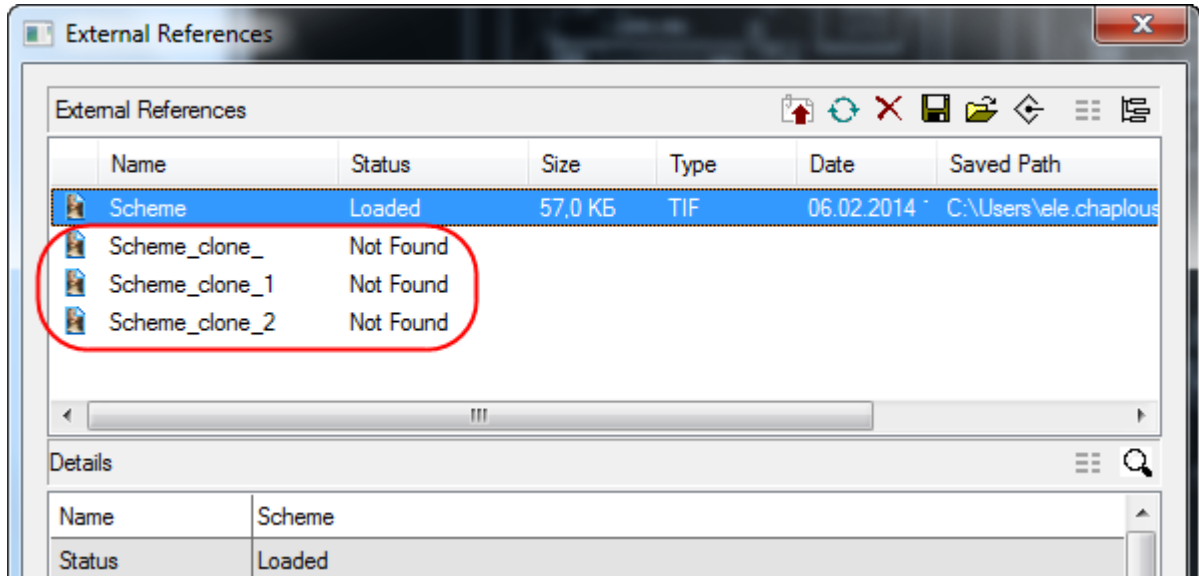

You can give new name and path for raster image if click the **Save** button.

If separate raster images are not saved, then program prompts you to save them on exit.

## Embed Raster Image

In nanoCAD there is a mechanism for embedding of raster images. Inserted images saved in external raster files can be embedded and saved in drawing file.

### To embed the raster:

1. Open dialog **External References** (menu **Insert** – **External References**).
2. Select reference to a raster image.
3. Click the  **Embed image** button.

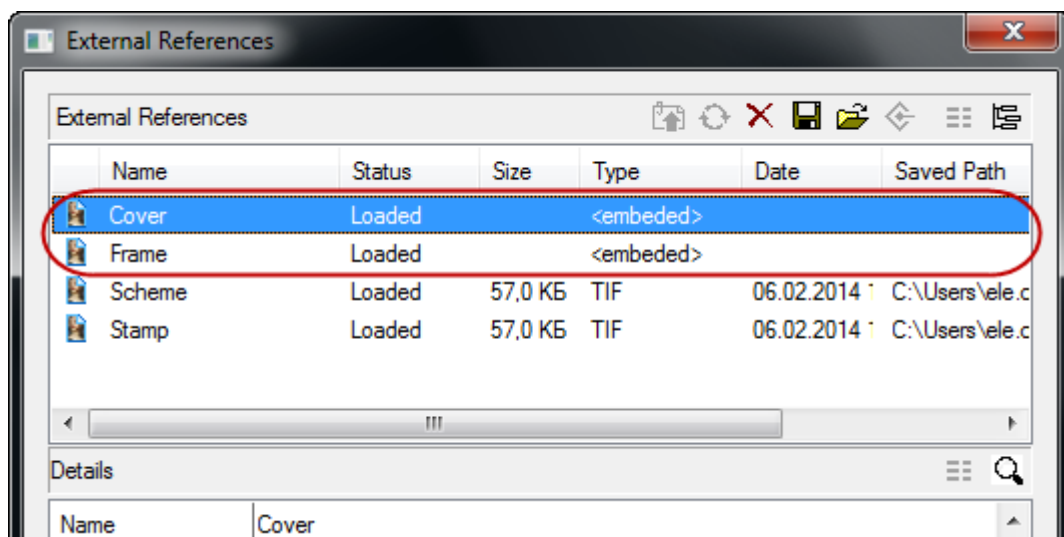

Embedded image has no saved path, and type of reference becomes *Embedded*.



**ATTENTION!** Embedded raster images increase the file size greatly.

**ATTENTION!** In programs that do not support the mechanism for embedding bitmap images, there may be problems with their display.

Using  **Save file** dialog command and assigning saved path you can make the image inserted as reference again.

## Image settings

nanoCAD allows you to convert the inserted images into other supported raster file formats. The list of supported raster file formats is shown in the **Options** dialog box (the **Tools** menu – the **Options** command).

For the **TIFF** format, you can also change settings such as color mode, compression, organization, byte order; for **JPG** and **JPEG** formats – Image Quality.

*To save an image to another format or to change the format parameters:*

1. In the **External References** dialog box select raster references and click **Save**.
2. In the opened **Save Image File** dialog box, type the new file name, select the file type from the drop-down list and click the **Options** button.
3. Depending on the selected file type, the [TIFF Options](#) dialog box or the [JPEG Options](#) dialog box will be open.

## Displaying quality of raster images

The commands in this section adjust the display of raster images on the screen without modifying their raster data. Changes made by these commands will not in any way affect the display of the same images in another document or another program.

### Image Adjust



Ribbon: **Raster – Settings** >  **Image Adjust**



Menu: **Raster** –  **Image Adjust**



Toolbar: **Modify Object** – 



Command line: **IMAGEADJUST, IAD**

You can adjust the brightness, contrast and fade for the display of the raster image without affecting the original raster image file. The image adjustment is intended for improvement of the display of raster images (adjust contrast to make poor-quality images easier to read) or special effects.

**NOTE:** To change the intrinsic brightness, contrast, hue and saturation of raster images, use the **Brightness/Contrast (LEVELS)** command. This command, unlike the **Adjust Raster** command, modifies the raster image data. 

Bitonal images cannot be adjusted for brightness, contrast or fade.

Raster image is selected by its contour (frame or clip border).  
 To adjust raster image options, use the **Image Adjust** dialog box.

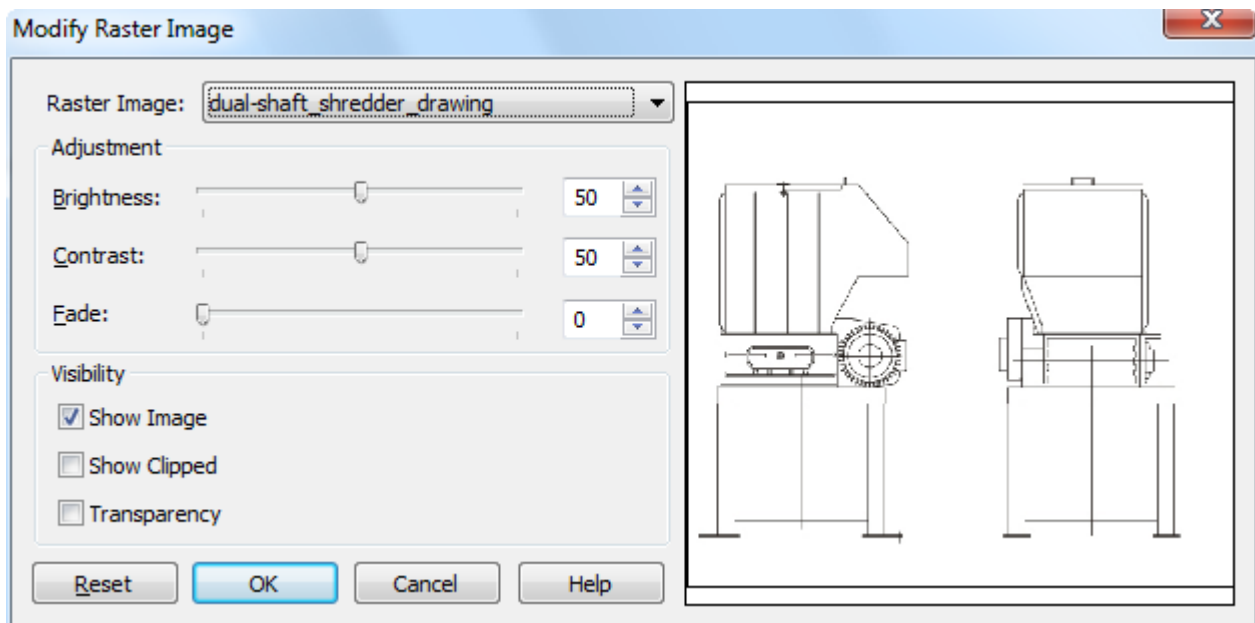

**Parameters:**

**Raster Image:** List of the raster images inserted in the drawing.

*Adjustment*

**Brightness:** Controls the brightness of the raster image display.

**Contrast:** Controls the contrast of the raster image display.

**Fade:** Controls the fading effect of the raster image display.

These parameters are also available in the **Image Adjust** section of the **Properties** functional bar:

Image Adjust	
Brightness	50
Contrast	50
Fade	0

*Visibility*

**Show Image** Controls the display of the image content on the screen. If this checkbox is not selected, then only the contour of the raster image is shown.

**Show Clipped** If this checkbox is selected, only the clipped area of the raster image is displayed. Otherwise, the raster image is displayed completely, even if a clip has been set for it.

To set a clip for the raster image use the **Image Clip** command (ribbon > **Insert** tab > **Reference** > **Hatch** > **Image Clip**).

**Transparency** Used only for bitonal raster images and images with transparent pixels. Makes the background color of the image transparent. When enabling the transparency mode, it becomes possible to view

through transparent pixels of the raster image of objects that are in the graphics area behind the raster.

The transparency property is supported for those raster file formats in which transparent pixels exist, for example, in monochrome images (\*.BMP) background pixels are transparent.

These parameters are also available in the **Misc** section of the **Properties** functional bar:

Misc	
Name	3ea70dadd6f653f86e9155...
Saved Path	D:\My documents\3ea70d...
Color depth	TrueColor
Pixel width	620
Pixel height	584
Resolution	72.00 per inch
Show image	Yes
Show clipped	No
Background transparency	No

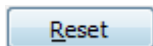

Resets the values for brightness, contrast and fade to the default settings.

You can set transparency level for the raster image as for drawing object.

**To change the transparency of the raster image as drawing object:**

1. Select the raster image.
2. Select a transparency value in the **Transparency** drop-down box in the **General** section of the **Properties** panel.

The **IMAGEFRAME** system variable allows you to manage the visibility of the clipping contour and raster contour. If the system variable is set to value **1** (set by default), the contour is displayed on the screen and you can select it and print it. If system variable is set to value **0**, the contour visibility is turned off and you cannot select it and print it. If system variable is set to value **2**, the contour is displayed on the screen, but you cannot print it.

There are commands in the **Raster** menu – **Object** > **Image** > to make work with **IMAGEFRAME** system variable easier:

- Frame On** - Sets **IMAGEFRAME** = **1**
- Frame Off** - Sets **IMAGEFRAME** = **0**
- Print Off** - Sets **IMAGEFRAME** = **2**

## Quality of Raster Images

This function changes quality of raster images from high (by default) to draft, accelerates image downloading and improves system performance when processing large images.



Ribbon: **Raster – Settings** >  **Image Quality**



Menu: **Raster** –  **Image Quality**



Command line: **IMAGEQUALITY**

**To change the quality of raster image:**

1. Run command **Image Quality**.
2. Select the required option in the command line: **IMAGEQUALITY <High>: [High/Draft]**.

## Transparency of Raster Images Background



Ribbon: **Raster – Visualisation >**  **Transparency**



Menu: **Raster –**  **Transparency**



Command line: **TRANSPARENCY**

Changing the transparency of raster images background on the screen.

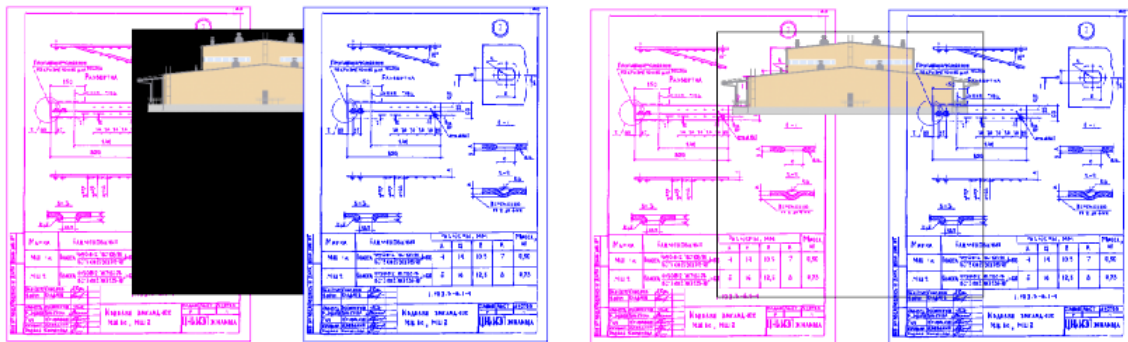

The command allows you to switch the transparency of the background pixels of bitonal raster images (for example, TIF format), as well as the alpha channel pixels of color images (for example, PNG format).

**NOTE:** The command switches the transparency of raster images background only on the screen. Raster images are not modified.

**To change the transparency of raster image background:**

1. Run the command.
2. Select the required option: Enter transparency mode **[ON/OFF] <ON>**:

The background transparency of selected raster images can also be changed in the **Properties** bar.

Resolution	300.00 per inch
Show image	Yes
Show clipped	No
Background transparency	Yes <span style="float: right;">▼</span>
	No
	<b>Yes</b>

## Correcting Raster Image Geometry

This section provides procedures for correcting geometric distortions in monochrome, color, and grayscale raster images. Such operations are applied before using more complex procedures such as interleaving or vectorization.

### Resizing a Raster Image



Ribbon: **Raster – Modification** >  **Change Size**



Menu: **Raster** –  **Change Size**



Command line: **IMAGESIZE**



This functionality is available only in the Raster module.

It is used to bring the image size in accordance with predetermined values.

It is advisable to carry out after performing such operations as deskewing and cropping the image, as well as after scanning, which results in an image of a non-standard size. If the new image is smaller than the original one, the image is cropped. If the new image is larger than the original one, margins are added to the image. Changes are tracked in the preview window.

The operation can be applied to only one image.

Select an image and run the command.

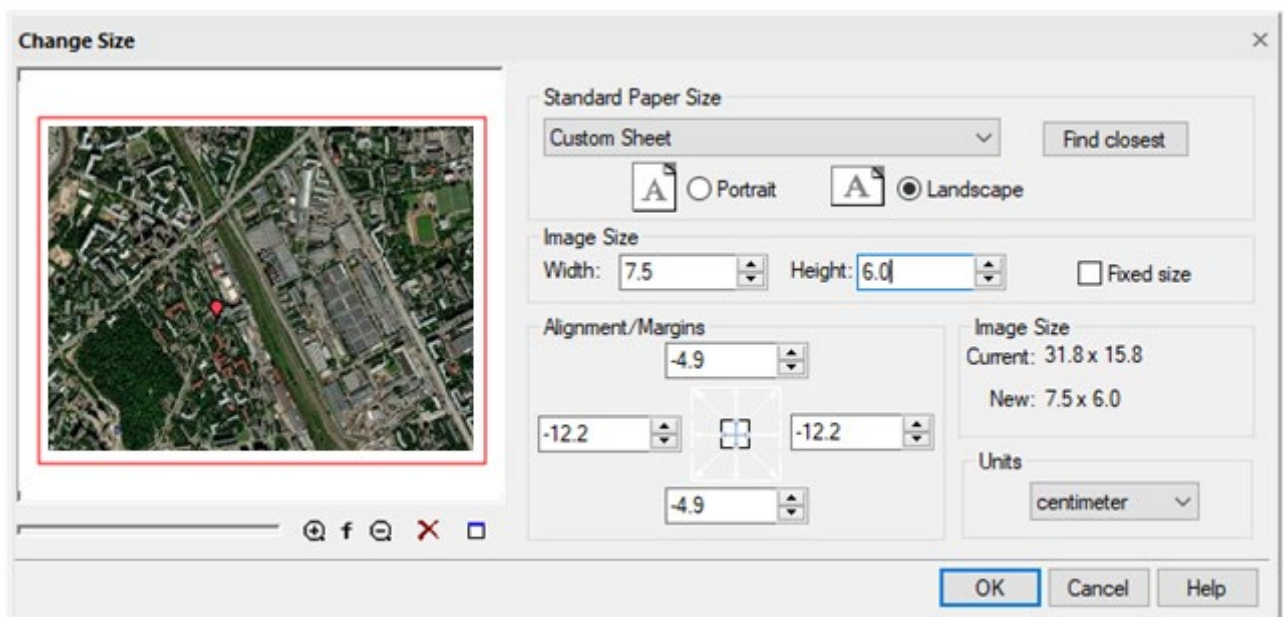

In the dialog box that appears, set the following parameters:

1. In the **Units** field, select measurement units from the list;
2. Determine the required image size by one of the following ways:
  - Automatically determine the closest format – click the **Find closest** button in the **Standard Paper Size** section;
  - In the **Standard Paper Size** list, select one of standard paper formats and the required orientation (Landscape or Portrait). You can customize the **Standard Paper Size** list in the **Papers** section of the **Options** dialog;
  - Enter values in the **Width** and **Height** fields of the **Image Size** section;

- If you work with a color or grayscale image, the color of added image edges is specified by the **Layout Background Color** parameter in the **Color settings** section of the **Options** dialog box;
  3. Align the image using one of arrows of the **Alignment/Margins** field. For example, you can align the image to the top left by clicking the top left corner arrow. To center the image, select the central button;





4. Specify sizes of the image margins by one of the following ways:
  - Resize the image by increasing or decreasing the margins. To do this, clear the **Fixed size** checkbox and, using the appropriate fields in the **Alignment/Margins** section, increase or decrease the size of margins in required directions by entering positive or negative values in the appropriate fields;
  - Align the fixed size of the image by changing the margin values. Check the **Fixed size** box. Then for the required image margins, enter the changed values in the appropriate fields;
5. Press **OK**.

## Changing Image Resolution

 Ribbon: **Raster – Modification** >  **Resample**

 Menu: **Raster –**  **Resample**

 Command line: **RESAMPLE**

 This functionality is available only in the Raster module.

The operation allows you to proportionally change geometric dimensions (scale) of an image and its resolution (DPI).

When scaling, the image dimensions in pixels can be changed or left unchanged. In the latter case, the image is resized in relative units (millimeters or inches) by changing the resolution value.

You can change the image in pixels by:

- Changing the actual image size while maintaining the resolution value;
- Changing the resolution;
- Changing the actual image size and its resolution.

**ATTENTION!** When changing the image resolution without a corresponding change in its size, the image file size will be proportional to the square of its resolution. For example, a 200 ppi image file is four times the size of an image file of the same size and 100 ppi resolution.

The operation can be applied to only one image.

1. Select an image and run the command.
2. Specify the parameters in the **Resample** dialog box that appears.

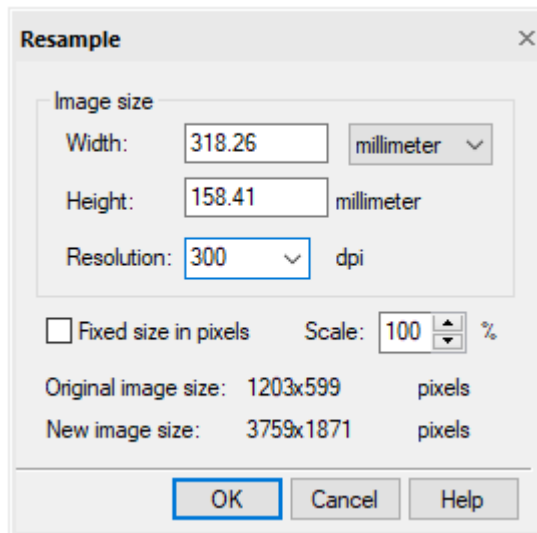

3. If you want to save the original image size in pixels, check the **Fix size in pixels** box;
4. To increase or decrease the image size by changing the value of image pixels, clear the **Fix size in pixels** box.
5. Select the measurement units from the list;
6. Specify the image size in the required way:
  - Enter new values for the image width or height in the **Width** or **Height** fields (with selected pixels as a measurement unit and the checked **Fix size in pixels** box these values are blocked). When you enter any value in one field, the value in another one changes automatically to maintain the image proportions;
  - Enter the scale factor as a percentage of the current image size in the **Scale** field. If the **Fix size in pixels** box is checked, then setting a new actual size affects the resolution value. The image size in pixels remains unchanged. If the **Fix size in pixels** box is cleared, then setting a new actual size affects the size in pixels. The image resolution remains unchanged;
7. To change the image resolution, enter the required values in dots per inch (dpi) in the **Resolution** field. If the **Fix size in pixels** box is checked, then the program remains the image size in pixels unchanged, changing only the image resolution;
8. Click **OK**.

## Editing of Raster Images

### Cropping of Raster Images

The size of raster image can be reduced to determined area by using Crop operations. This area can be determined by set clip of image or rectangle. Also, raster can be cropped automatically using procedure that determines empty image fields and crops them.

These operations apply to multiple images at once. For example you can crop pack of images by placing them on top of each other.

### Automatic crop

Automatic crop trims the "empty" image field to the smallest possible rectangle that includes all raster data.



Ribbon: **Raster – Crop – Crop** >  **Auto**



Menu: **Raster – Crop –**  **Auto**



Toolbar: **Raster –** 



Command line: **CROPAUTO**

1. Select raster to be processed on the screen. If there was no selected images, then the command processes all visible images placed in non-locked layers.
2. Run the command.

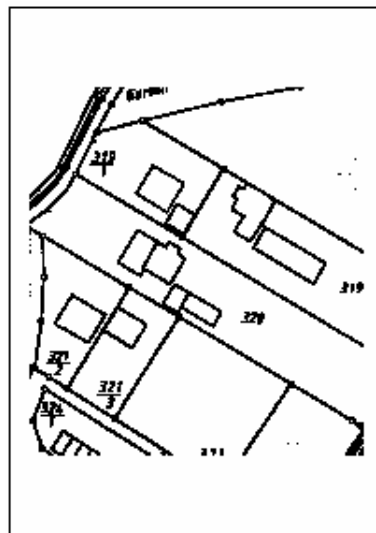

**Original raster image**



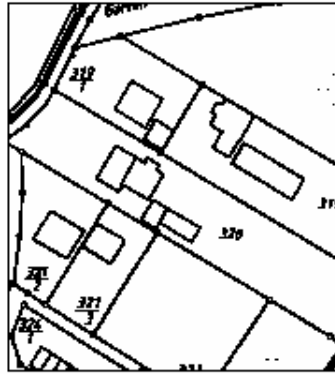

The result of the Automatic crop command

## Auto crop by frame

If the raster has a frame, then the command automatically changes the size of raster by the frame.

 Ribbon: **Raster – Crop – Crop >  By Frame**

 Menu: **Raster – Crop –  Auto by frame**

 Toolbar: **Raster – **

 Command line: **CROPBYFRAME**

If the image has deformations, use the **Deskw** command for correct CROPBYFRAME behavior.



1. Select raster to be processed on the screen. If there was no selected images, then the command processes all visible images placed in non-locked layers.
2. Run the command.



If the raster has no frame, then the result of Auto crop by frame is similar to the **Crop → Auto**.

## Crop by Rectangle

Cropping can reduce an image size to a specified rectangular area size.

 Ribbon: **Raster – Crop >  By Rectangle**

 Menu: **Raster –  Crop by Rectangle**

 Toolbar: **Raster – **

 Command line: **CROPBYRECT**

1. Start the command.
2. Specify two opposite corners for the rectangular area in the raster.

Parts of an image outside the specified area are cropped.

## Crop by clip

 Ribbon: **Raster – Crop >  By Clip**

 Menu: **Raster – Crop –  By Clip**

 Toolbar: **Raster – **

 Command line: **CROPBYCLIP**

To crop the raster by clip, the clip of the raster image should be predefined (**Modify** → **Clip** → **New...** command).

1. Select raster to be processed (visible and placed in non-locked layers). If there was no selected images, then the command processes all visible images placed in non-locked layers that have the clip.
2. Run the command.

The raster image will be cropped by the clip of the raster image.

## Mirroring

The operation allows mirroring an image around either vertical or horizontal axis crossing the image center.

 Ribbon: **Raster – Align >  Mirror By X axis**

 Ribbon: **Raster – Align >  Mirror By Y axis**

 Menu: **Raster – Mirror >  By X Axis**

 Menu: **Raster – Mirror >  By Y Axis**

 Toolbar: **Raster –  **

 Command line: **MIRRORX, MIRRORY**

1. Select images to mirror. If no image is selected, then this command processes all visible images located on unlocked layers.
2. Start the command **Raster Modify – Mirror >** select condition:
  - **By X Axis**, to flip image vertically;
  - **By Y Axis**, to flip image horizontally.

## Rotation

The operation rotates image around a central point, using three fixed rotation angles (90°, 180° or 270°) or any angle. When an image is rotated at any angle the image size increases to inscribe rotated initial image.

**To rotate at 90°, 180°, 270° angles:**

 Ribbon: **Raster – Align >  Rotate 90 ccw**

 Ribbon: **Raster – Align >  Rotate 180**

 Ribbon: **Raster – Align >  Rotate 90 cw**

 Menu: **Raster – Rotate >**

-  **90 ccw**

-  **180**
-  **90 cw**

 Toolbar: **Raster** –   

 Command line:

- **ROTATEAT90**
- **ROTATEAT180**
- **ROTATEAT270**

Select the images to rotate. If no image is selected, then this command processes all visible images located on unlocked layers.

Start the command **Raster Modify – Rotate** > select rotation condition.

### *To rotate at custom angle:*

 Ribbon: **Raster – Align** >  **Rotate Custom Angle**

 Menu: **Raster – Rotate** >  **Custom Angle...**

 Toolbar: **Raster** – 

 Command line: **ROTATEATANGLE**

1. Select the images to rotate. If no image is selected, then this command processes all visible images located on unlocked layers.
2. Start the command.
3. Enter rotation angle to **Angle** field.

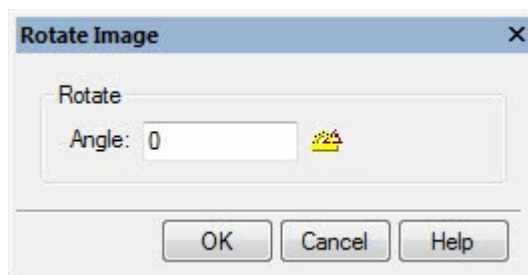

Or press  **Measure** and specify line by 2 points. Angle will be measured between this line and X-axis.

4. Select **OK**.

## **Deskewing**

This operation enables an image skew resulting from scanning to be corrected. The whole image is rotated about its central point in order to eliminate either horizontal or vertical skew. When an image is rotated at any angle the image size increases to inscribe rotated initial image.

 Ribbon: **Raster – Align – Deskew** >  **Auto**

 Ribbon: **Raster – Align – Deskew** >  **Manual**



Menu: **Raster – Deskew >**

-  **Auto**
-  **Manual**



Command line:

- **DESKEWAUTO**
- **DESKEW**



Toolbar: **Raster Modify –**



### *To deskew an image automatically:*

1. Select the images to deskew. If no image is selected, then this command processes all visible images located on unlocked layers.
2. Start the command **Deskew > Auto**.

If the program is able to estimate the rotation angle, then raster images will be deskewed. Otherwise, use the manual deskewing procedure.

### *To deskew an image manually:*

1. Select the images to deskew. If no image is selected, then this command processes all visible images located on unlocked layers.
2. Start the command **Deskew > Manual**.
3. Enter angle value to the **Angle** field.

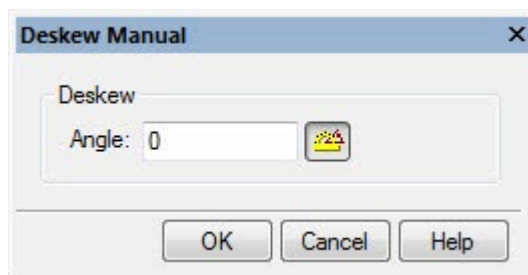

Or press  **Measure** and specify line for deskew by start and end points.

4. Press **OK**.

## ***Correction by Four Points***



Ribbon: **Raster – Crop >**  **4 point correction**



Menu: **Raster –**  **4 point correction**



Toolbar: **Raster –** 



Command line: **FRAMING**

The command is used for correction of scanned images with frame. It is suggested that the image frame and its content are distorted equally.

To perform this procedure, specify the desired frame size – its height and width, and the appropriate current position of the frame corner dots on the image. After correction the image is



transformed so that the frame corners are moved to the rectangular frame corners of the specified size, whose sides are parallel to image sides.

If no image is selected, then this command processes all visible images located on unlocked layers.

**To perform four point correction:**

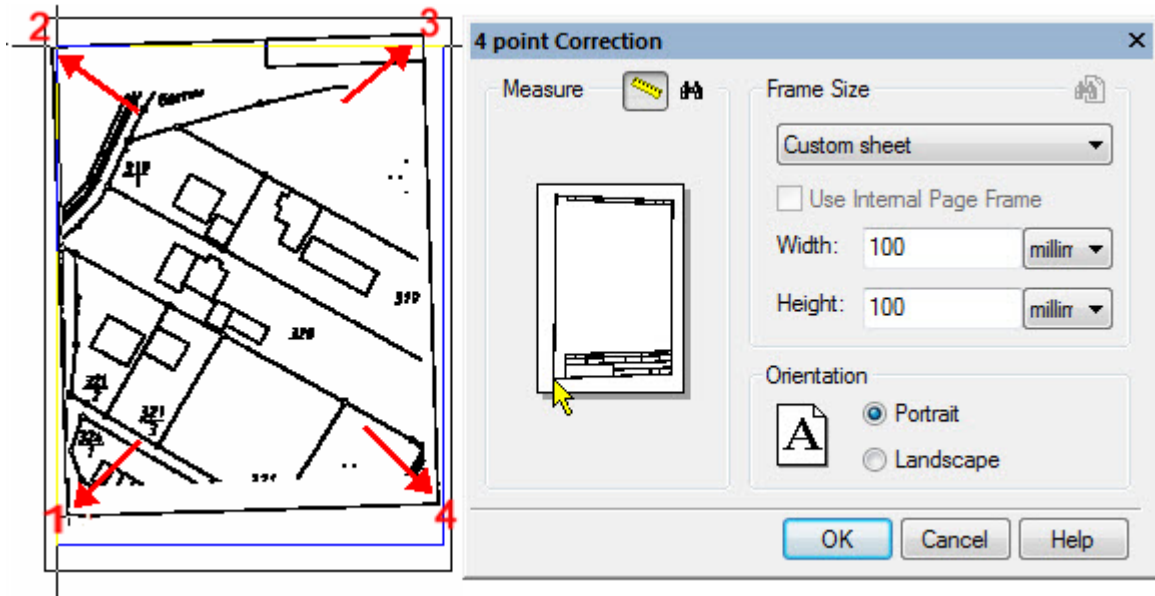
1. Select the images to correct by four-point correction. If no image is selected, then this command processes all visible images located on unlocked layers.
2. Start the command. The **4-point Correction** dialog will be displayed:



3. Click the **Find frame**  button. If the program is able to find the drawing frame, then you will see a blue polygon over the image close to the raster lines. If a frame is not found specify it manually.
4. To specify the frame corners manually, press the  button and click the frame corners on the image. These points can be specified in an arbitrary order because the program always sorts them so they form the frame without intersections. Watch the red rubberline to control, press **BACKSPACE** to go to previous frame corner if necessary.
5. In the **Frame size** field specify **Width** and **Height**.
6. Select orientation – **Landscape** or **Portrait**.
7. Press **OK**.

**Find closest format** button  starts searching closest standard paper format.

Or you can select format manually in **Frame Size** combo-box.

For standard paper formats you can use the **Use internal frame** option to correct frame size depending on paper format settings. Internal frame size can be defined in **Papers** section of the **Options** dialog ( **Tools - Options**).

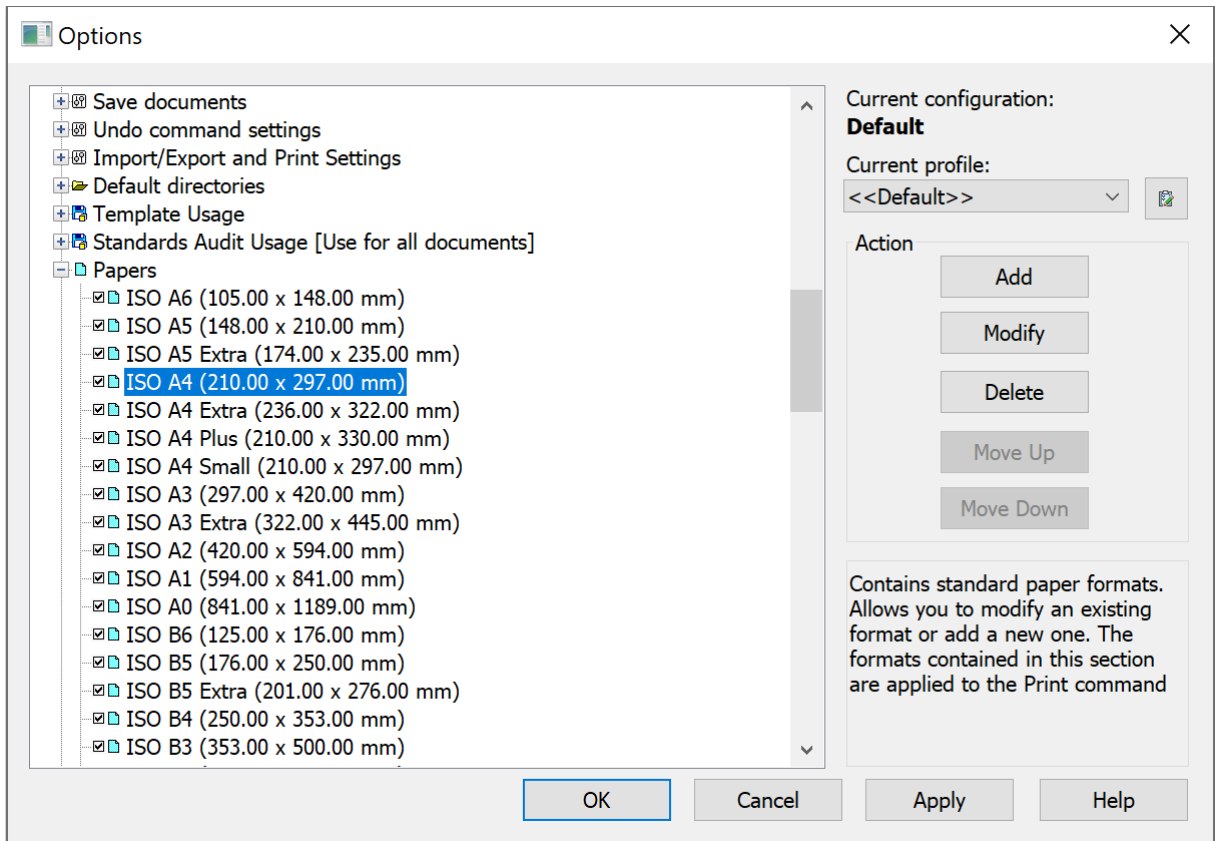

**Set the internal page frame size:**

1. Select paper format in **Paper formats** section.
2. Press **Modify** button.
3. In the **Modify paper format** dialog - set **Internal frame** and specify margins in **Frame margins** fields.

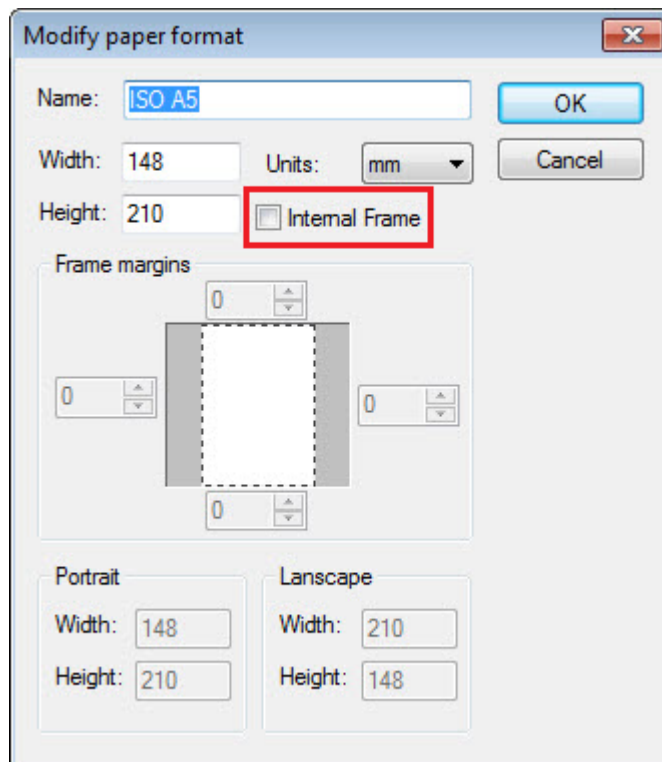

For paper formats without internal frame specified, the **Use Internal Page Frame** option in **4-point Correction** dialog will be disabled.

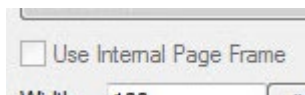

## Calibration



Ribbon: **Raster – Modification >**  **Calibration**



Menu: **Raster –**  **Calibration**



Command line: **CALIBRATION**



This functionality is available only in the Raster module.

The calibration operation affects the entire image. When multiple images are selected, the command is applied to visible images located on unlocked layers.

The calibration transformation is determined by the transformation model and a set of calibration pairs.

When preparing calibration, it is necessary to specify the vectors of raster points displacement. To do this, specify a *set of calibration pairs*. Each of these pairs determines two coordinates - the current position of a point on the image (*measured point*) and its required theoretical position (*real point*).

A *transformation model* is a type of parametric transformation used in calibration. Each model determines a family of transformations of the same type.

When using some sets of calibration pairs and individual methods, the program is not able to perform the transformation of a given type in such a way that all measured points move to the corresponding real points. This leads to deviation of the points obtained as a result of transformation from the corresponding real points. The criterion for choosing the conversion parameters is to minimize the root-mean-square error at all calibrated points.

Each of the calibration pairs is one of the following types:

- *Grid* – if a pair is part of the calibration grid; used in calculating the calibration parameters and assessing the calibration accuracy;
- *Check* – if a pair is used when calculating the calibration parameters and assessing the calibration accuracy;
- *Control* – if a pair is used only to assess the calibration accuracy and does not affect the calibration parameters;
- *Unused* – if a pair is not used when calculating the calibration parameters and assessing the calibration accuracy.

### Basic Calibration steps

1. run the calibration command;
2. create a set of calibration pairs;
3. specify the position of measured points;
4. choose a suitable calibration method;
5. calibrate.







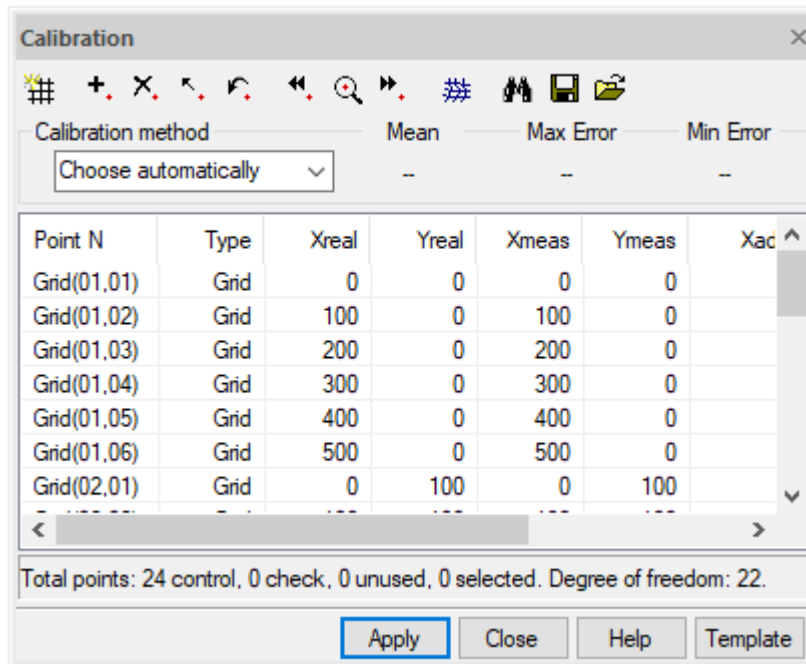

Before performing the calibration, it is recommended to set the coordinate system - origin and scale.

### Calibration command

The command opens the calibration dialog box.



### Calibration dialog button

Button	Description
 Define grid	Creates a set of calibration pairs located at the nodes of a rectangular grid
 Add point	Creates a calibration pair using a dialog box
 Modify point	Allows you to change the location of the measured and real points, as well as the type of selected calibration pair
 Reset point	Moves measured points to real points position for selected calibration pairs
 Delete point	Removes all selected calibration pairs from the list and their corresponding points in the drawing
 Previous point	Pans the drawing to show the previous calibration pair in the center of the screen
 Zoom to point	Pans the drawing to show the selected calibration pairs in the center of the screen
 Next point	Pans the drawing to show the next calibration pair in the center of the screen
 Estimate	Estimates calibration accuracy

### Specifying a set of calibration pairs

When creating calibration pairs, their definitions are added to the list in the **Calibration** dialog box:

1. Specify the known theoretical coordinates of points (real points) in one of two ways: by specifying a calibration grid or adding points one by one, or both at the same time. When created, each calibration pair has the same coordinates of measured and real points;
2. Set the corresponding measured points for all real points by selecting them in the image or by entering their coordinates from the keyboard.

### Setting the calibration grid

When specifying a calibration grid, it creates a set of calibration pairs, the points of which are located at the nodes of a rectangular grid. Such calibration pairs relate to the **Grid** type.



The position of the calibration pair points specified when creating a grid is determined by the origin of the grid, the cell size, and the number of cells in the horizontal and vertical directions.

There can be only one grid in a calibration object. Re-setting the calibration grid will delete all calibration pairs belonging to the existing grid.

Click the **Define grid** button

The **Calibration grid** dialog box appears:

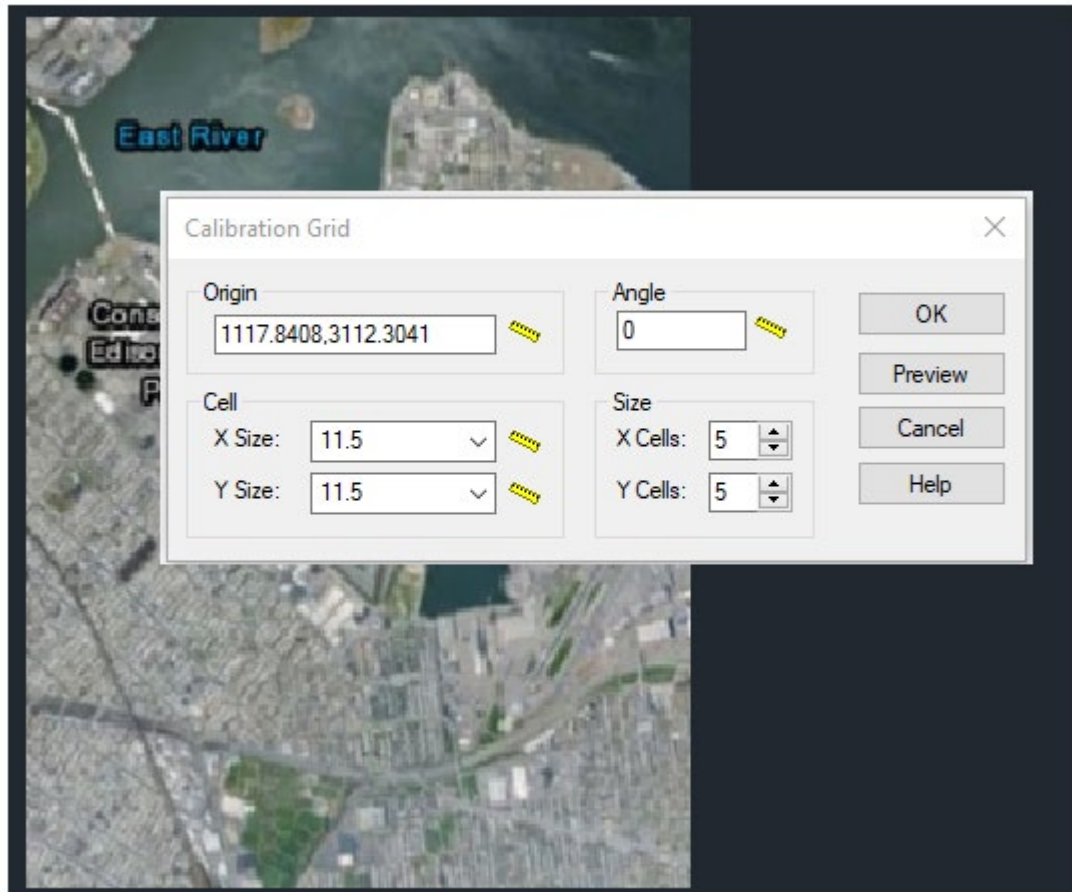

1. Specify the calibration grid origin;
2. Enter coordinates in the **Origin** field or click the **Choose origin** button and specify with the mouse the location of the grid origin in the image. The bottom left corner of the grid is taken as the grid origin, and the grid is generated in the positive direction of X and Y axes;
3. Set cell dimensions along X and Y axes;
4. If necessary, you can also add columns in the negative direction of X or Y axes by specifying a negative value for the X or Y dimensions;
5. Specify the number of cells along X and Y axes using the **X cells** and **Y cells** respectively;
6. To avoid errors, click the **Preview** button and view the specified grid. If necessary, correct errors;
7. Select **OK** to create a calibration grid and return to the **Calibration** dialog box.

You can create a rectangular grid rotated by a specified angle. Otherwise, the grid rows and columns will be orthogonal to the X and Y axes.

### Setting the calibration grid through the loaded file

To add an arbitrary calibration grid, it is possible to create a text file with the RPT extension. After specifying the coordinates and parameters of all real calibration points in it, and starting the calibration dialog before starting to change the measured calibration points, you should load this file through the **Import grid** button.

#### RPT file format:

first line:

- Unsigned Int – Calibration method

second line:

- Unsigned Int – Number of points

next lines (separated by a space):

- Unsigned Int – Sequential number of the calibration pair
- Double – Real point x coordinate
- Double – Real point y coordinate
- Double – Measured point x coordinate
- Double – Measured point y coordinate
- Double – Calculated point x coordinate (identical to x-measured point before calculation)
- Double – Calculated point y coordinate (identical to y-measured before calculation)
- Bool – Check point
- Bool – Control point?
- Bool – Used point?
- Unsigned Int – Sequential number of point in the grid along x axis (starting from 0)
- Unsigned Int – Sequential number of point in the grid along y axis (starting from 0)

String – Point label (name)

#### Example of RPT file

```

10
16
0 414.250000 -312.500000 415.789786 -311.284805 414.250000 -312.500000 1 1 1 0 0 Grid(01,01)
1 436.250000 -312.500000 437.410740 -310.659621 436.250000 -312.500000 1 1 1 1 0 Grid(01,02)
2 458.250000 -312.500000 460.386260 -308.679871 458.250000 -312.500000 1 1 1 2 0 Grid(01,03)
3 480.250000 -312.500000 481.694622 -309.044562 480.250000 -312.500000 1 1 1 3 0 Grid(01,04)
4 414.250000 -288.500000 414.799911 -285.027068 414.250000 -288.500000 1 1 1 0 1 Grid(02,01)
5 436.250000 -288.500000 431.221632 -307.526974 436.250000 -288.500000 1 1 1 1 1 Grid(02,02)
6 458.250000 -288.500000 464.815333 -257.650194 458.250000 -288.500000 1 1 1 2 1 Grid(02,03)
7 480.250000 -288.500000 419.868235 -297.301982 480.250000 -288.500000 1 1 1 3 1 Grid(02,04)
8 414.250000 -264.500000 414.250000 -264.500000 414.250000 -264.500000 1 1 1 0 2 Grid(03,01)
9 436.250000 -264.500000 436.250000 -264.500000 436.250000 -264.500000 1 1 1 1 2 Grid(03,02)
10 458.250000 -264.500000 458.250000 -264.500000 458.250000 -264.500000 1 1 1 2 2 Grid(03,03)
11 480.250000 -264.500000 480.250000 -264.500000 480.250000 -264.500000 1 1 1 3 2 Grid(03,04)
12 414.250000 -240.500000 414.250000 -240.500000 414.250000 -240.500000 1 1 1 0 3 Grid(04,01)
13 436.250000 -240.500000 436.250000 -240.500000 436.250000 -240.500000 1 1 1 1 3 Grid(04,02)
14 458.250000 -240.500000 458.250000 -240.500000 458.250000 -240.500000 1 1 1 2 3 Grid(04,03)
15 480.250000 -240.500000 480.250000 -240.500000 480.250000 -240.500000 1 1 1 3 3 Grid(04,04)

```

### Adding calibration pairs one at a time

When using this method, pairs are added one by one. The created pairs can be of one of the following types: *Check*, *Control* or *Unused*. This procedure is designed so that you can create pairs by specifying only the real point coordinates. The measured points can be specified later.

Adding points:

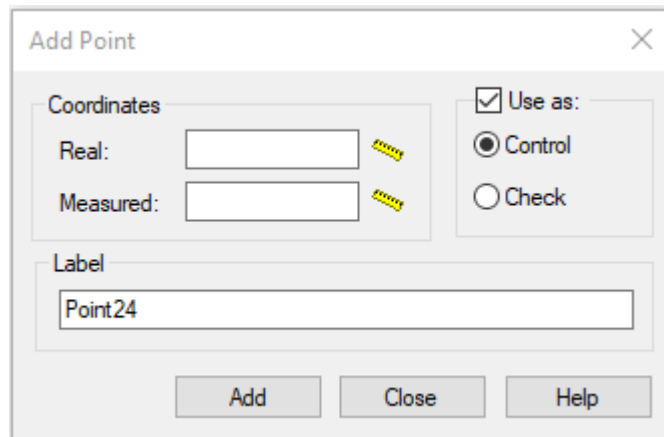

1. Select **Add** in the context menu or click the **Add point** button located in the **Calibration** dialog box. The dialog box for adding a point will appear;



2. Enter the real point coordinates in the **Real** field;
3. Enter the pair name in the **Label** field, otherwise this pair will be named **PointNN** by default;
4. Enter the measured points coordinates in the **Measured** field or specify them on the screen using  button. If this is not done, their coordinates will coincide with the real ones and can be changed later;
5. If necessary, in the **Use as** field, change the type of pair from *Control* to *Check* or, by clearing the checkbox, define the pair type as *Unused*;
6. Press **ENTER** or select **Add** to create the pair and continue the operation.

### Specifying measured points on the screen

The measured points can be specified on the screen using the mouse:

1. Select the calibration pair to be changed from the list of the **Calibration** dialog box or on the screen. The program will highlight the selected point with help of "grips";
2. Specify the selected pair using  button or by the **Zoom to** command of the context menu. The program pans the image so that to show the measured point of the selected pair in the center of the screen;
3. Change the location of the measured point. Place the cursor over the "grips" and left-click. Move the cursor and click again to determine a new location of the measured point;
4. Move to the next or previous calibration pair. Select **Next** or **Previous** in the context menu or click  or  button on the toolbar of the **Calibration** dialog box. The program will pan the image so that to show the next (previous) measured point of the selected pair in the center of the screen.

### Choosing a calibration method

A calibration method is chosen taking into account the nature of image distortion, as well as the number and location of calibration pairs.

If there is no information regarding image distortion, you can use the **Choose automatically** method. In this case the program itself will choose the calibration method that is optimal for a given set of calibration pairs.

The table lists possible distortions and calibration methods used to correct them.

**Calibration methods to correct distortions**

Method	Distortions
Linear conformal	For linear transformations (moving, rotation, and proportional scaling).
Affine	For linear transformations (moving, rotation, and non-proportional scaling); raster ellipses can be converted to circles.
Bilinear	For 4-point parallelogram or trapezoidal distortions.
Grid adaptive bilinear	For complex raster grid distortions (more than four calibration pairs required); can only be used if there is a given grid.
Polynomial	For non-planar distortion in aerial photography caused by the uneven surface of the Earth.
Surface Splines	For distortions of all types; this is the most accurate method that works on an arbitrary set of pairs.

Each calibration method assumes the minimum number of calibration pairs the model can use. If the number of calibration pairs exceeds a certain value, all models except Surface Splines will produce non-zero distortion.

The following table lists the limits on the number of calibration pairs for each calibration method:

**Limitations on the number of pairs for each distortion correction method**

Method	Number of calibration pairs	Number of calibration pairs giving a non-zero error
Linear conformal	2	3
Affine	3	4
Bilinear	4	5
Grid adaptive bilinear	Necessary to specify the calibration grid	Points specified do not belong to the grid
Polynomial 2 degree	6	7
Polynomial 3 degree	10	11
Polynomial 4 degree	15	16
Polynomial 5 degree	21	22
Polynomial 6 degree	28	29
Surface Splines	3	Not applicabel

**Calibration accuracy estimation**

Calibration transforms the entire raster image through a calculated transformation. Usually not only the points specified in the calibration pairs are moved, but all the image points. Accuracy estimation allows you to determine the offset of each raster point for the selected calibration method prior to performing the calibration procedure.

During the estimation, another point is created for each calibration pair, called the *calculated* one. It shows the position of the measured point after performing the selected calibration method. Labels of such points are highlighted in yellow (labels of real points – blue, labels of measured points - red; you can change these default colors in the **Options** dialog box). Then the

program calculates and displays the distances between each calculated point and the corresponding real point. These distances determine the calibration deviations for each pair.

The program calculates the parameters of the selected method, therefore, after transformation, each measured point is placed as close to the corresponding real point as possible. For these calculations the program uses only calibration pairs of the control and grid types.

To estimate the displacement of any point in the image after calibration, it is necessary to create a calibration pair with measured and real points that have the coordinates of the required image point and assign this pair a check type. This pair will not be considered when determining the transformation parameters, but the program will find the calculated point for it and calculate the deviation from the actual point location.

### To estimate the calibration accuracy

1. Create calibration pairs required to correct image distortions.
2. Specify the location of the measured points.
3. If necessary, create test pairs to determine the direction of movement of arbitrary pairs.
4. Select the desired method from the list of calibration methods. Only models applicable to a given set of calibration pairs can be used. If these requirements are not met, the estimation cannot be completed.
5. Click the  button located in the **Calibration** dialog box.

The **Mean error** parameter shows the mean error of the chosen method. Note also the **Xerr** and **Yerr** values, which are used to estimate the error of each point when using the chosen method.

## Color Correction



This functionality is available only in the Raster module.

A real map or color scheme, as a rule, is performed using a small number of colors, however, when scanning a paper original, a color raster image is obtained, the points of which have several tens or even hundreds of colors. Color filtering and color correction tools are used to prepare images for subsequent complex operations such as binarization, slicing, raster editing, and vectorization. Color filters are also used to improve the quality of images after applying operations that move objects in the image or change the resolution (scaling, alignment, rotation, calibration, or four-point correction).

### Conversion to True Color, Grayscale and 256 Colors



This functionality is available only in the Raster module.

A raster image can be converted to color modes: TrueColor (full color), Grayscale (half-toned), and to indexed colors.

Conversion operations can be applied to several images of the same type at the same time.

Converting monochrome images to grayscale, TrueColor or indexed color models makes it possible to apply color filters to them (**Blur**, **Adaptive blur**, **Contour Sharpness**, **Average**).

#### Conversion to True Color (Full Color)



Ribbon: **Raster – Processing – Convert to 24 bits** >  **Conversion to True Color**



Menu: **Raster – Processing the raster – Convert to –**  **True Color.**



Command line: **CONVERTTO24**

1. Select images.
2. Perform the command.

## *Conversion to Grayscale*



Ribbon: **Raster – Processing – Convert to 24 bits** >  **Convert to Grayscale**



Menu: **Raster – Processing the raster – Convert to** –  **Grayscale**



Command line: **CONVERTTOGRAYSCALE**

1. Select images.
2. Perform the command.

## *Conversion to the Indexed Colors*



Ribbon: **Raster – Processing – Convert to 24 bits** >  **Convert to 256 Colors**



Menu: **Raster – Processing the raster – Convert to** –  **Convert to Indexed colors**



Command line: **CONVERTTO256COLORS**

The command allows you to reduce the image file size by changing the color depth. The command also provides the ability to fine-tune the colors. As a result of its application to an image represented by the True color model, the number of colors used is reduced to 256 (or less). You can further reduce the number of colors by deleting selected colors or merging several colors into one. You can replace selected colors and add them to the palette.

1. Select the images to be converted.
2. Run the command.

The **Convert to indexed colors** dialog has a preview window, a table of current colors and editing tools.

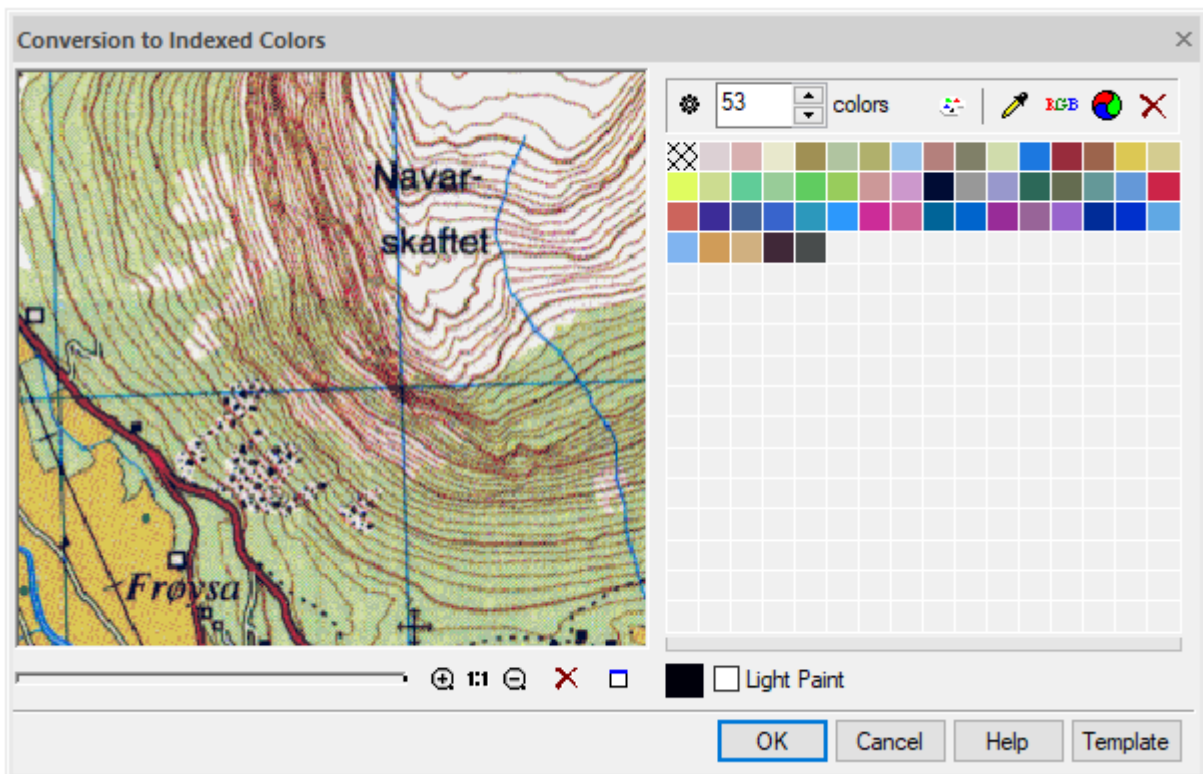

### **Convert automatically**

To obtain an image with the maximum possible number of colors, enter the value 256 (suggested by default) in the color field and click  **Reset palette** button.

To automatically reduce the number of colors in the selected image, click  **Set auto palette** button.

If the results are satisfactory, click **OK** in the preview window

### **Setting the number of colors in the palette**

Set the desired value in the color counter  colors, click  **Reset palette** button. The palette will be automatically rearranged in order to display the image in the best possible way in the colors, the number of which is set in the counter.

### **Removing a color from the palette**

1. Select the color(s) to be removed from the table. Multiple colors are selected while holding down the **SHIFT** key.
2. Click  **Delete selected colors** button. The image will be redrawn in a new palette.

### **Adding a color to the palette or replacing one color with another**

1. Select a color in the table to be replaced, or point to an empty square if you want to add a color.
2. Click  **Get color to set** button and specify the required color to be added or replaced in the dialog box.

To get color from an image: click  **Choose color to change palette** button, specify the point on the raster image.

### **Combining multiple colors into one**

1. Select multiple colors in the table while holding down the **SHIFT** key.

2. Click  **Merge colors** button. The selected colors will be reduced to one of the colors existing in the palette, which is as close as possible to the average value of all selected ones.

Changes are controlled in the preview window.

Click **OK** to apply changes to the image.

## Changing Brightness, Contrast, Hue and Saturation



Ribbon: **Raster – Processing** >  **Brightness/Contrast**



Menu: **Raster – Processing the raster** >  **Brightness/Contrast...**



Command line: **LEVELS**



This functionality is available only in the Raster module.

Using the **Brightness/Contrast** command, you can adjust brightness, contrast, hue and saturation of pixels of one or several color or grayscale images.

*Brightness* characterizes the relative lightness or darkness of a color and is measured as a percentage: from 0 (black) to 100 (white).

Changing the *contrast* allows you to increase or decrease the brightness differences in the image pixels. An image with the same pixel brightness has zero contrast. Increasing the contrast increases the differences in brightness by darkening dark colors and brightening bright colors. The contrast of an image changes as a percentage: from 0 (solid gray) to 100. The hue is usually understood as the color, and the saturation is the color purity. The command allows you to completely change the color content of an image.

*Hue* is the wavelength of light reflected or transmitted through an object. Typically, a color name (red, orange, green, etc.) is used to describe a color tone. Each hue occupies a specific position on the standard color wheel and is characterized by an angle ranging from  $-180^\circ$  to  $+180^\circ$ .

*Saturation* is the degree of a color purity. It defines the ratio of gray to a given hue and is expressed as a percentage: from 0 (gray) to 100 (fully saturated).

1. Select color or grayscale raster images to be processed.
2. Run the **Brightness/Contrast...** command.
3. In the dialog box, use the corresponding input fields or sliders for changing values of **Brightness**, **Contrast**, **Hue** and **Saturation** parameters.

In the preview window, you can observe the change in parameters.

Click **Apply**.

The **Reset** button sets 0 value for all parameters.



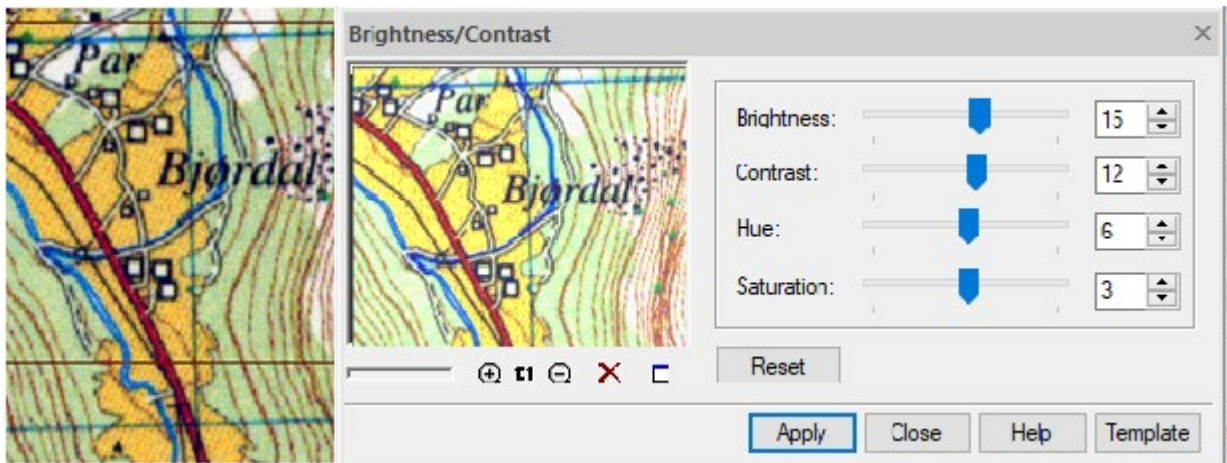

## Correction by Histogram



Ribbon: **Raster – Processing** >  **Equalize**



Menu: **Raster – Processing the raster** >  **Equalize...**



Command line: **EQUALIZER**



This functionality is available only in the Raster module.

The operation is used to adjust the brightness, color hue and contrast of an image. To do this, a histogram correction algorithm is used with the setting of two threshold brightness levels - the darkest and brightest pixels, as well as the image gamma, which determines the position of the average brightness value relative to the current threshold values.

Gamma specifies the ratio of length of the brightness range between the average and the brightest values to the length of the brightness range between the dark threshold and the average value. As a result of using the command:

- pixels with a brightness value below the dark threshold receive a zero brightness value;
- pixels with brightness values higher than the brightest - maximum brightness value (255);
- the brightness values of pixels lying between the darkest and average values and between the average and the brightest levels are redistributed evenly in accordance with the lengths of the intervals given to them, which are determined by the image gamma.

Increasing the gamma value decreases the interval provided for brightness in the dark range and therefore increases the contrast in it, while simultaneously decreasing the contrast in the light range, and vice versa.

The command allows you to redistribute both the average brightness of the image pixels and the brightness by individual color components of pixels (Red, Green and Blue). This allows you to correct the color of pixels in the image - for example, make a pink background pure white.

1. Select raster images to be processed.
2. Run the command.

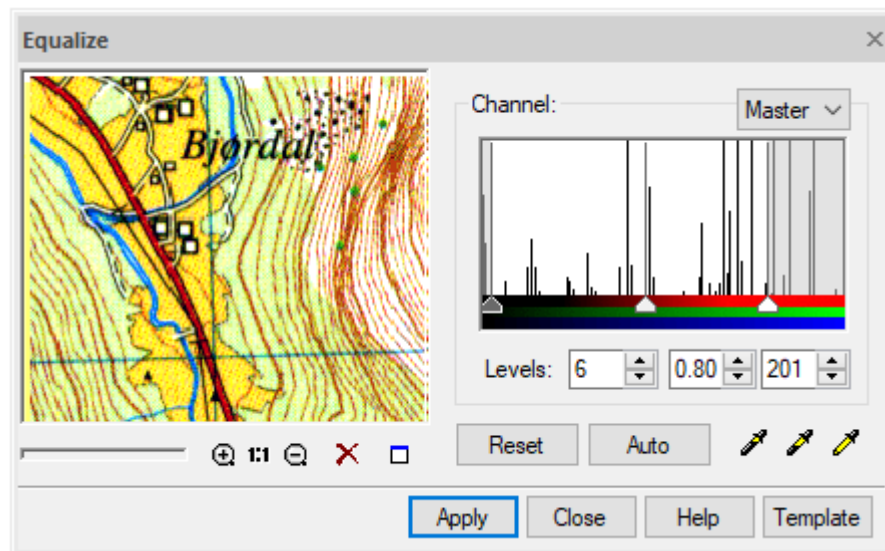

The **Equalize** dialog box presents the image histogram that shows the averaged number of pixels corresponding to each brightness value:

- low brightness values correspond to the left side of the histogram;
- high (lightest tones) - the right side of the histogram.

The slides at the bottom of the histogram show the threshold values: black on the left is the darkest, gray in the middle is the average, and white on the right is the brightest pixel.



It is possible to choose one of four histograms:

- **Master** shows the summarized distribution of pixel brightness;
- **Red, Green** and **Blue** show the brightness distribution of the corresponding color components of pixels (red, green, and blue).

Select the histogram corresponding to the color component to be corrected.

Set the brightness values of the darkest, lightest pixel and gamma of the image using the **Levels** fields or the eyedropper. For fine tuning, use the histogram sliders.

The **Levels** fields contain a numerical expression of the current thresholds. Using the sliders of the **Master** histogram, you can proportionally change the values of the thresholds of all components at the same time. The **Red, Green, and Blue** histogram sliders change the brightness thresholds separately for their respective color components. The eyedroppers are used to select thresholds and gamma in an image. If a color sample is taken by an eyedropper

 **Pick low level** (or  **Pick high level**), then the value of the darkest (brightest) threshold component is set. If a color sample is taken by an eyedropper  **Pick middle level**, the middle tone position is defined and thereby – the image gamma. The brightness values of all other pixels will be proportionally redefined within the boundaries of the new tone range. Moving the middle slider changes the gamma value and redistributes the contrast between the light and dark parts of the image.

The **Auto** button automatically sets the values of the light and dark thresholds so as to cut off the brightness values for each color component that are not found in the image.

Click **Apply** to perform the operation.

This correction can be performed repeatedly by sequentially changing the brightness distribution of the image pixels.

## Gamma Correction



Ribbon: **Raster – Processing** >  **Gamma Correction**

 Menu: **Raster – Processing the raster >  Gamma Correction ...**

 Command line: **GAMMAEDIT**

 This functionality is available only in the Raster module.

This operation is used to enhance the overall quality of an entire image by changing its so-called “color profile” through an algorithm that changes the distribution of brightness of image points.

Points with intermediate values of color intensity are usually unevenly distributed and form a curve (gamma) of an arbitrary shape. The gamma value determines the slope of the curve exactly halfway between the white and black points. Changing the gamma increases or decreases the brightness of points that fall within a certain brightness range, as well as changes the brightness of red, blue and green colors.

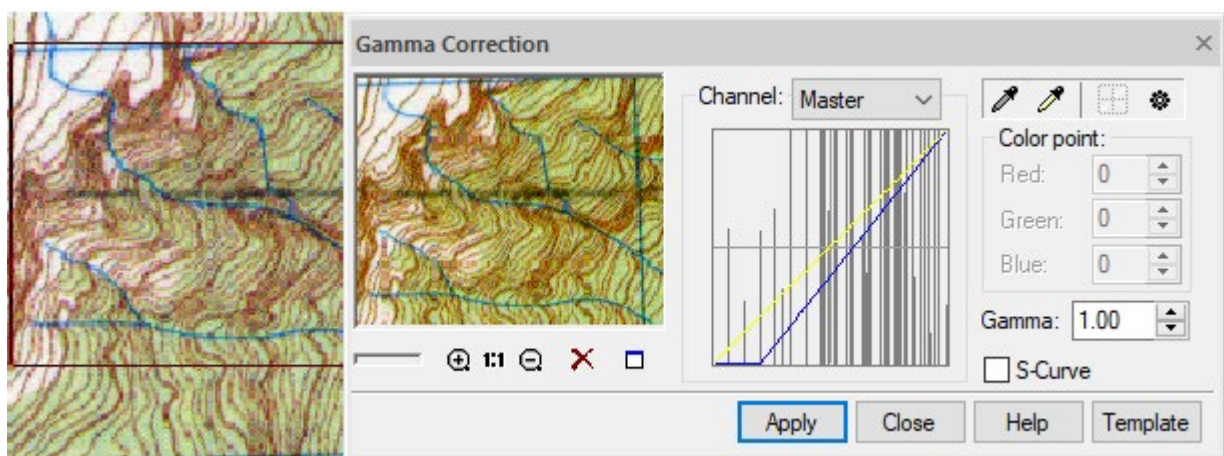

1. Select raster images to be processed.
2. Run the command.



In the **Gamma Correction** dialog box that opens:

3. Set white and black points by selecting them with the eyedroppers on the image.
4. Select a color channel.
5. Create a gamma curve automatically or adjust it manually.
6. Click **Apply**.

### **Setting black and white points**

To select the values of white and black points directly on the image, use the eyedroppers  **Black point** and  **White point**. Select the appropriate eyedropper and outline an area on the screen.

You can fine tune the color values in the **Color point** section of the dialog box.

If color values other than (0,0,0) for black and/or (255,255,255) for white points are specified in this section, then points outside the specified range will not be gamma corrected.

The  **Auto set** button calculates the white and black point values for each color channel. The histogram in the middle of the dialog box displays the distribution of brightness of the colors. The curve can be changed for each channel separately.

Press to return the gamma curve to its original view, click .

### **Changing the gamma curve**

There are three ways to change the shape of gamma curve of the **Master** channel and curves of individual channel curves. These ways are interconnected.

1. Check or clear the **S-Curve** box. S-curve is a form of gamma curve that is always symmetrical about the center point of the distribution range. This means that by adding brightness to dark areas, we automatically darken bright areas to the same level and as a result the image looks better balanced in brightness. If the **S-Curve** checkbox is cleared, you can create a gamma curve by moving the overall brightness balance in the resulting image.
2. Entering a value in the **Gamma** field changes the slope of the curve.
3. Move the curve of the **Master** channel or curves for individual channels in the histogram window.

If the **Master** is selected in the **Channel** list, all curves are shown.

When you move the mouse cursor over the curve, a marker appears in the form of a point, which can be moved by changing the slope of the curve. If you hold the mouse cursor on the curve, you can see the real distribution of brightness of the image colors.

To change the shape of curves for red, blue and green channels, select the corresponding channel from the **Channel** list.

In some images you can also "split" the Master curve into components (red, blue and green) by clicking the **Auto set** button.

## *Editing Color Palette (Color Classifier)*



Ribbon: **Raster – Processing** >  **Color classifier**



Menu: **Raster – Processing the raster** >  **Color Classifier...**



Command line: **PALEDITOR**



This functionality is available only in the Raster module.

With the help of edit operations, the color palette of the image can be calculated automatically or changed based on the colors specified by the user.

Colors in the image are managed in the **Color Classifier** dialog box. The dialog tools allow you to:

- reduce the palette by deleting selected colors or combining several colors into one;
- replace the selected colors;
- add new colors in the palette;
- save the customized palette for use when processing the same type of color images.

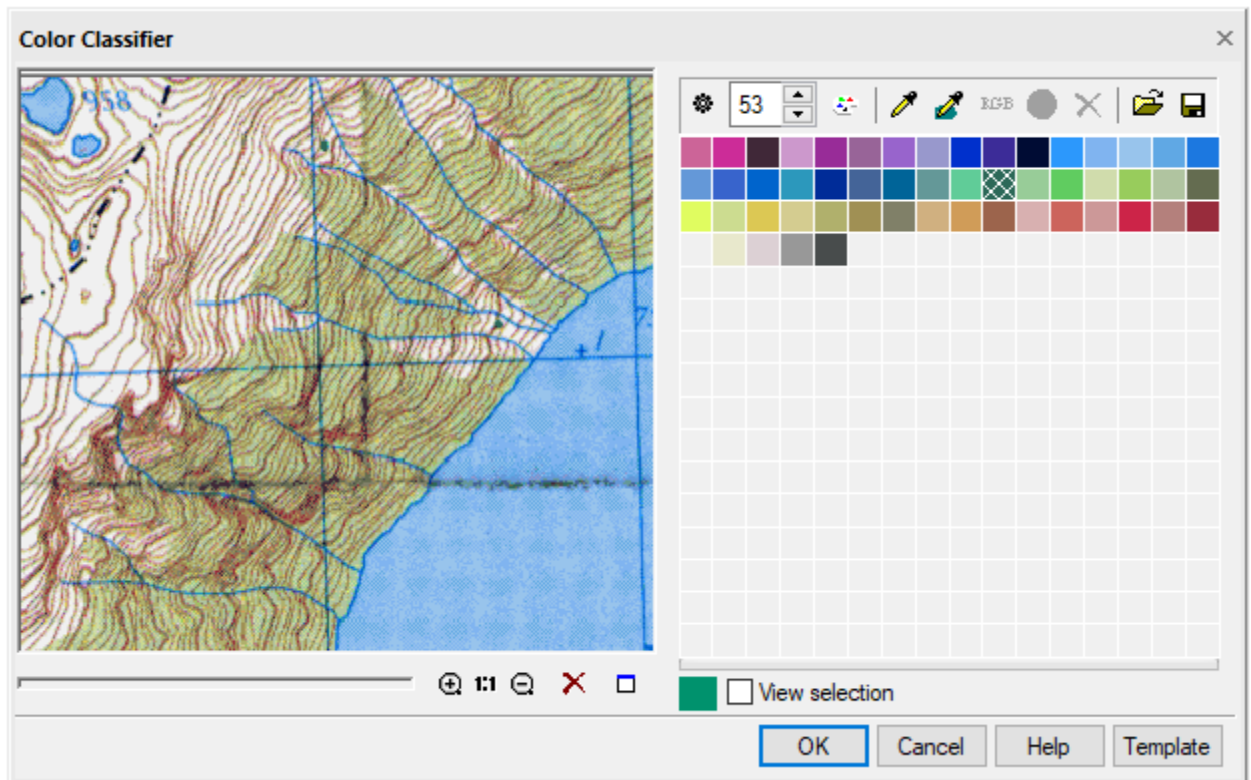

### *Set auto palette*

Click the  button. The program will automatically determine the set and number of colors that represent the image the most accurately.



### *Create a new palette*

Set the number of colors in the **Color Counter** field or edit the palette in the **Color samples table**.

Click  button. It is used to recalculate the palette based on the number of colors specified in the **Color counter**. The changes are controlled in the preview window. When the required result is achieved, click **OK**.

### *Color selection*

Methods:

- specify the color in the **Color samples table** by the mouse; several colors are selected while holding down the **SHIFT** key;
- click  button, specify the point in the image; the selected color will be highlighted in the table;
- Click  button, select the area in the image with a polygon; colors contained within the specified polygon will be highlighted in the table (to close the polygon, press the right mouse button or **ENTER**).

You can control the selected colors in the image using the **View selection** tool.

### *Delete color from the palette*



1. Select color(s) to be deleted.
2. Click **Delete colors** button.

You can reduce the number of colors by setting their number in the counter window and clicking  button.

### Add color to the palette or replace existing one

1. Select the colors to be replaced or specify an empty square if you need to add a color.
2. Click  button and specify in the dialog that opens the color to be added or replaced.

### Merging several colors into one

1. Select several colors in the table while holding down the **SHIFT** key or specify them in the image using  tool.
2. Click  button.

The **Apply** button starts application of the settings made.

## Filtering Color Raster Images

### Blur

 Ribbon: **Raster – Filters – Blur** >  **Blur**

 Menu: **Raster – Filters** >  **Blur...**

 Command line: **GAUSSBLUR**

 This functionality is available only in the Raster module.

The filter has the effect of blurring the image, creating the impression that the image is slightly out of focus. Blur filtering reduces the image sharpness, but makes the image areas containing texture fills more uniform, which makes it easier to binarize or separate the image by color.

When calculating a pixel color, the program replaces its color value with the one averaged over the neighborhood.

*Radius* is the only filter parameter. The higher its value, the more blurry the image becomes.

1. Select images on the screen to be processed and start filtering in one of the following ways.
2. Run the command.
3. In the **Radius** field enter the value from 0.1 to 10.0 to set the degree of the image blurring. The higher the value, the stronger the blur effect.
4. Select **Apply** to start filtering.

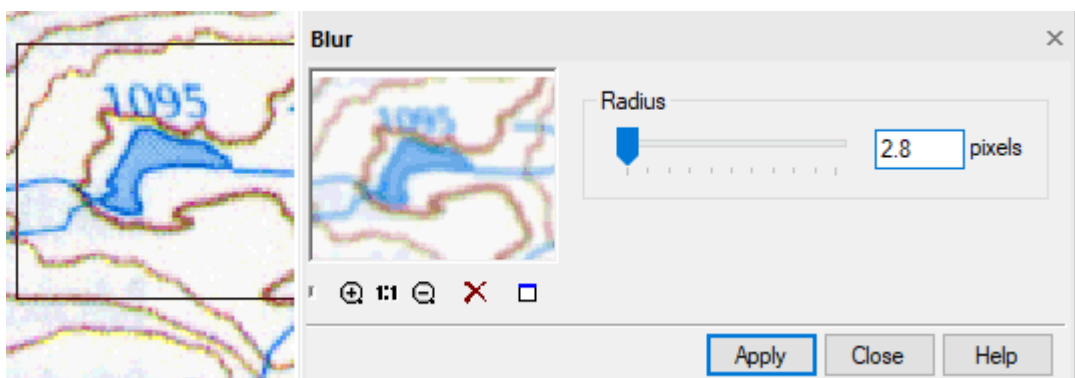

## Adaptive Blur

 Ribbon: **Raster – Filters – Blur** >  **Adaptive blur**

 Menu: **Raster – Filters** >  **Adaptive blur...**

 Command line: **ADAPTIVEBLUR**

 This functionality is available only in the Raster module.

Adaptive blur allows, while maintaining sufficiently clear boundaries between contrasting colors, to smooth out areas of similar colors. This makes it possible to eliminate grain and remove “printing raster” in color and grayscale images.

The **Radius** parameter determines the number of pixels at the border of the transition of colors analyzed during the operation.

Run the command. In the **Adaptive Blur** dialog box:

1. In the **Radius** field, enter the value from 0.1 to 10.0 or regulate the parameter with the slider. The changes are controlled in the preview window;
2. When you get a desired result, click **Apply** to start the operation.

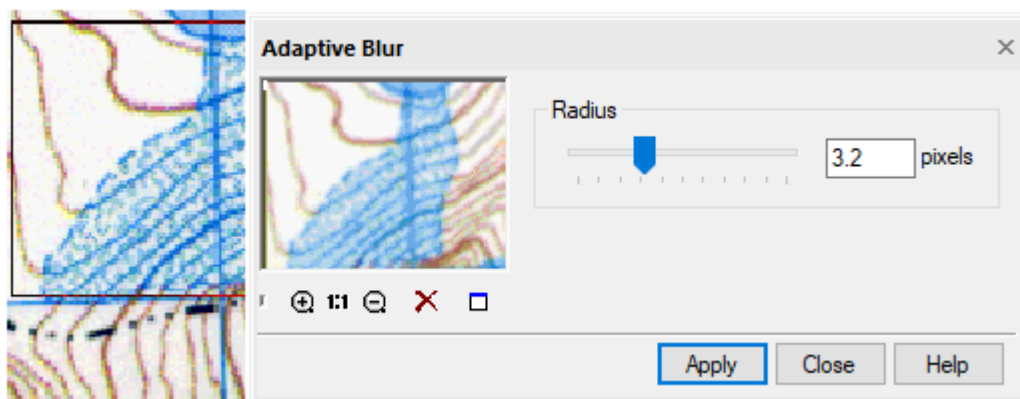

## Contour Sharpness

 Ribbon: **Raster – Filters** >  **UnSharp Mask**

 Ribbon: **Raster – Filters** >  **Unsharp mask...**

 Command line: **UNSHARPMASK**

 This functionality is available only in the Raster module.

The filter finds the boundaries of color transitions in the image and sharpens them.

The filter changes the contrast of pixels at the boundaries of color transitions, producing an overall sharpening of the image. It can be used to correct images that are blurry as a result of interpolation (for example, after scaling, resizing, or calibrating).

1. Select the images on the screen to be processed.
2. Run the command.

3. Enter in the **Sensitivity** field or specify using the corresponding slider the value in percent (from 0 to 100). The higher the value, the stronger the filter effect.
4. Enter the **Radius** value. The radius determines the “depth” of the filter’s effect. The higher the value, the more pixels surrounding the transition border will be processed. Low values provide sharpening only at the boundaries themselves. To find the optimal value for the parameters of the entire image, first set them for a small typical area of the image in the preview window.
5. Select **Apply** to start filtering.

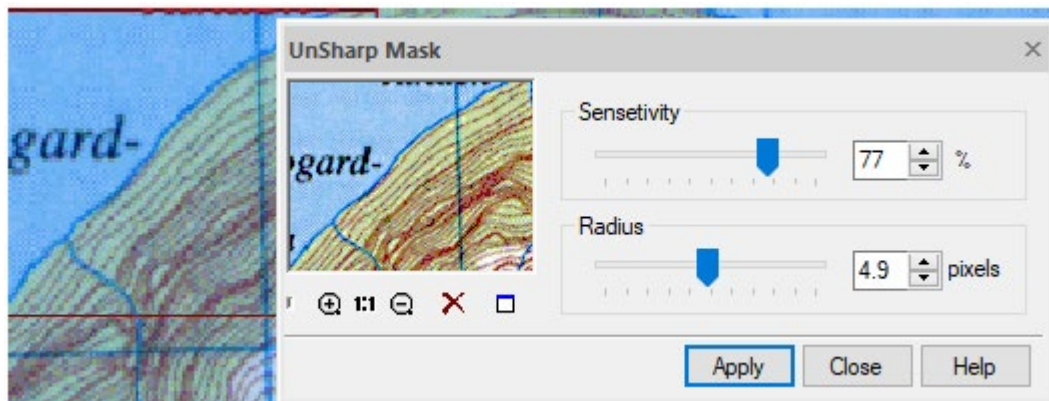

## Median

 Ribbon: **Raster – Filters** >  **Average**

 Menu: **Raster – Filters** >  **Median...**

 Command line: **MEDIANER**

 This functionality is available only in the Raster module.

Averaging filtering suppresses noise in the image by analyzing all pixels within a given radius and assigning the median value of the analyzed pixels characteristics to the central pixel. As a result, the color and brightness of the pixels are averaged.

1. Select the images on the screen to be processed.
2. Run the command.
3. Specify the **Radius** value in the range from 1 to 5. This value determines the radius of the neighborhood (in pixels) within which the filter will analyze color values.
4. To start filtering, select **Apply**.



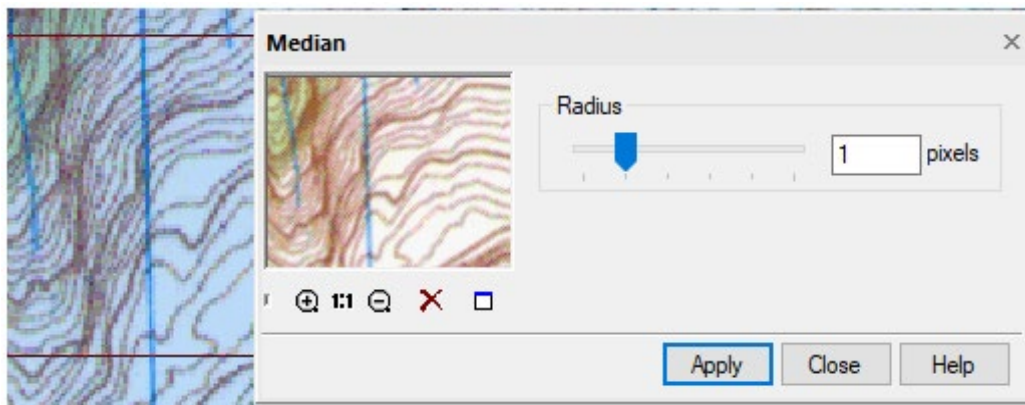

## Color Reducing



This functionality is available only in the Raster module.

This section describes the procedures for producing monochrome raster images (raster layers) from color and grayscale images.

The original image is a raster file obtained as a result of a color or grayscale scan. The binarization operation allows you to create monochrome raster images containing a black-and-white representation of objects in a color image. For example, objects of different colors (level lines, roads, rivers, etc.) can be sequentially extracted from one color image of a scanned map and placed on separate monochrome layers. This separation method allows you to place objects on one monochrome layer that correspond to one or more different colors in the original image.

Another way to get monochrome images from color ones is color layering. The program can convert a color image to a set of monochrome raster layers. At the same time, it is guaranteed that the black and white representation of all pixels of the original image will fall on this or that layer.

## Binarization



Ribbon: **Raster – Processing** >  **Binarization**



Menu: **Raster – Processing the raster** >  **Binarization...**



Command line: **BINARIZATION**



This functionality is available only in the Raster module.

When performing binarization, a new monochrome image of the specified color is created and placed on the specified layer. Using a certain criterion, the program determines the pixels of the original image (color or grayscale), which should become black (image pixels) and white (background), and then generates a monochrome image and places it on a new raster layer. The criterion for dividing pixels into two sets is determined by the selected binarization method and its parameters (threshold values or a set of color range). Pixels are placed on the image, they are selected in accordance with the setting specified in the tabs of the **Binarization** dialog box. The new monochrome image is named *Original Image Name\_N*, where N is an integer.

This operation can be applied to multiple images at the same time. If no image is selected, the command will be applied to all visible images located on unlocked layers.

Binarization works on images that have a display border. Using this property, you can limit the binarization area on any image by setting the display border for it.

## **Binarization methods**

To convert color and grayscale images to monochrome, various conversion algorithms are used, called binarization methods. It is recommended to select the conversion method appropriate for the type of image.

### **Brightness threshold**

The *Brightness threshold* method converts color pixels with brightness values above the specified level to background points, and below that level to image points.

This method can be used to convert both color and grayscale images. When converting a grayscale image, the program uses the grayscale of this image. When converting a color image, the grayscale is determined by the brightness value of colored points.

### **Threshold by RGB**

When using the *Threshold in RGB* method, specify three separate thresholds for the **Red**, **Green** and **Blue** components. The program converts colored points with Red, Green and Blue values below the corresponding thresholds to black points (image points) of a monochrome image.

### **Brightness ranges**

The *Brightness ranges* method converts colored pixels with any brightness value to image points. This method selects a number of base gray levels. These levels are used as the midpoints of the ranges. For each selected level, you can define the half-lengths of the ranges. The half-length of the range is the number of gray levels below and above the selected level.

Brightness ranges method converts pixels whose gray level is within the specified ranges to image points. The rest of the pixels are converted to background points.

This method can also be used to convert color and grayscale images. The gray level calculation for colored points is described in the Brightness Threshold section.

### **Ranges by RGB**

Using this method, you can convert color pixels belonging to specified RGB ranges to image points.

To set the *RGB range*, first select the center color of the range. **Red**, **Green** and **Blue** components of this color determine the position of the center point of the RGB range. For each color component (R, G and B), specify the corresponding half-lengths of the ranges. The red, green, or blue range half-length is the number of R, G, or B levels below and above the selected R, G, or B level. For example, if the R level for the selected color is 50 and the range half length is 10, then the RGB range contains colors with an R component from 40 to 60.

### **Ranges by HSV**

The *Range by HSV* method simplifies the conversion of RGB color images. It converts pixels of similar colors to image points. Colors that are similar from the point of view of human perception are called analogous (red - orange, dark green - light green, etc.).

To convert an image using the Range by HSV method, specify one or more HSV ranges. The HSV range is determined by the selected color and the half-lengths of the H, S, V ranges. The HSV range is similar in structure to the RGB range. **Hue** is expressed as an angle from 0° to 360°, and **Saturation** and **Value** - as a percentage from 0 to 100.

When converting grayscale images, the results of applying this method are of poor quality.

### **Configuring binarization**

To fine-tune the binarization procedure, you need to choose the appropriate method. The type of the selected method determines the tuning method. For each of the two threshold methods, you should assign one or three threshold values in the histogram. For any range method, you should specify a set of ranges of appropriate types that contain the colors to be extracted.

In addition, for any method, it is necessary to assign a layer on which the image obtained as a result of binarization will be placed.

The **Binarization** dialog box.

Until options are specified, the preview shows the original view of the image. But as soon as the selection of parameters begins, the results of binarization settings will be dynamically displayed in this window.

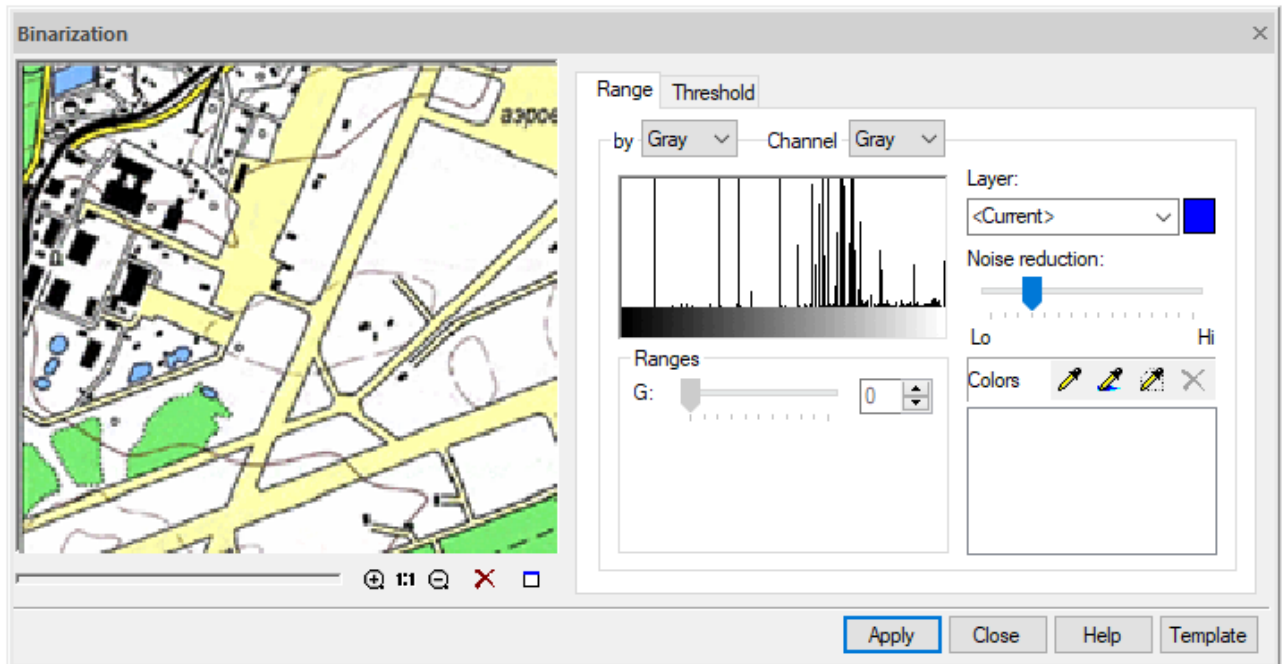

### Setting range binarization

In the **Binarization** dialog box, select the **Range** tab.



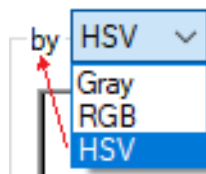

In the **By** list, select the desired type of the range method.



The adjustable parameters depend on the selected method.

Specify a set of ranges that capture the colors of those color image data (objects) that should be transferred to a separate monochrome layer.

### Adding a range

Click  or  button and specify in the image a pixel of the color of the data to be binarized . Or click  button and specify the area. An elements corresponding to the created range will appear in the **Colors** list. By successively clicking the buttons and indicating similar colors, achieve an acceptable result in the preview window.

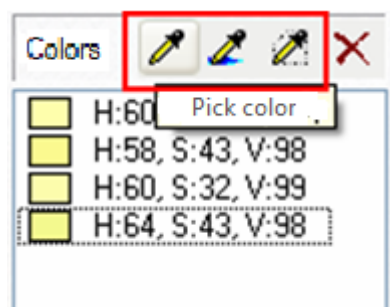

When configured, the preview window dynamically displays the results of adding each range. The most reliable results are obtained by viewing the image at a scale of 1:1.



### Changing parameters of the created range

If adding a range causes unwanted capture of image pixels, you can change its parameters using the channel histogram sliders or sliders and input fields in the **Ranges** section

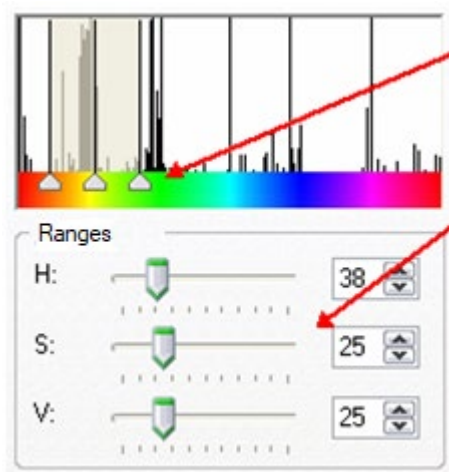

### Deleting a range

If you cannot achieve acceptable results by adjusting the range or it is selected by mistake, select it in the **Colors** list and click  **Remove color**.

Use the **Noise reduction** slider to improve the binarization quality.

To binarize large "filled" areas, increase the value of this parameter (closer to **Low** mark) to reduce the amount of raster "garbage" and unfilled holes in the objects obtained during binarization.

To obtain a monochrome image of small or thin objects (texts, symbols, level lines or grids), decrease the value of this parameter to prevent distortion of the shape of small objects.

Set the color and name of the layer on which the binarization result will be placed:

- enter the name in the **Layer** field;

- specify the layer's color by clicking on its swatch. Select **Color** in the windows that appears. Click **OK**.



### Configuring threshold binarization

In the **Binarization** dialog box, select the **Threshold** tab.

In the **By** list, select the required method

Find threshold values for the selected method.

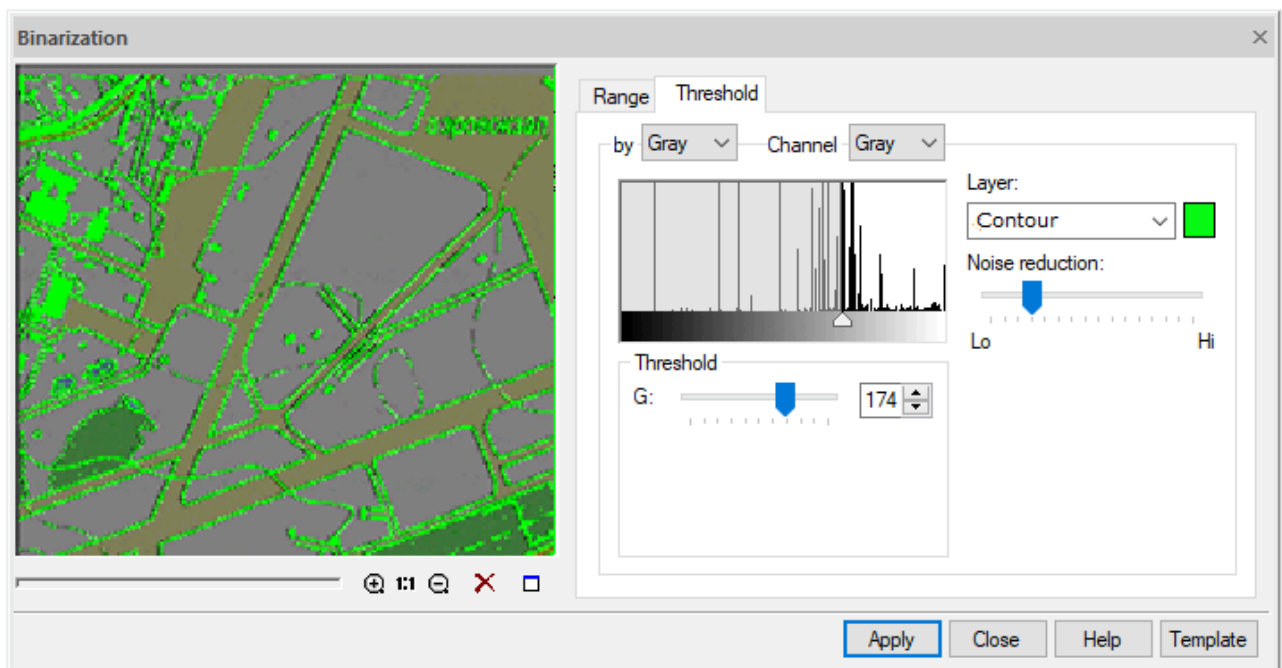

With the selected **Threshold by brightness** method, select **Gray** in the **Channels** list to see the gray level histogram. Specify the threshold value using the **slider** or **G slider**.

With the selected **Threshold by RGB** method, configure the threshold methods R, G and B. For this you can also use sliders on histograms of **Red**, **Green** and **Blue** channels.

Use the **Noise reduction** slider to improve the binarization quality.

Specify the color and name of the layer on which the binarization result will be placed.

Enter the name in the **Layer** field. To set the color, click on its swatch and make a selection in the window that appears. Click **OK**.

The binarization procedure is started by the **Apply** button.



The binarization result is a monochrome image of data having black and close to it pixel colors on the original color raster.

## Adaptive Binarization

 Ribbon: **Raster – Processing** >  **Adaptive Binarization**

 Menu: **Raster – Processing the raster** >  **Adaptive Binarization...**

 Command line: **FONESMOOTHER**

 This functionality is available only in the Raster module.

It is recommended to binarize scanned images made in grayscale mode from originals with a non-uniform background (blue, sepia) using the **Adaptive Binarization** tool. This operation combines binarization and image quality enhancement procedures. The program analyzes the boundaries of color transitions in an image and distributes pixels to the background and information.

The command can be applied to color images as well.

All parameters of the **Adaptive Binarization** dialog box are set using sliders or by entering values into the corresponding fields.

**Radius** is a “depth” of the filter effect. The higher the value of the radius, the more pixels surrounding the border of the color transition will be taken into account in the processing.





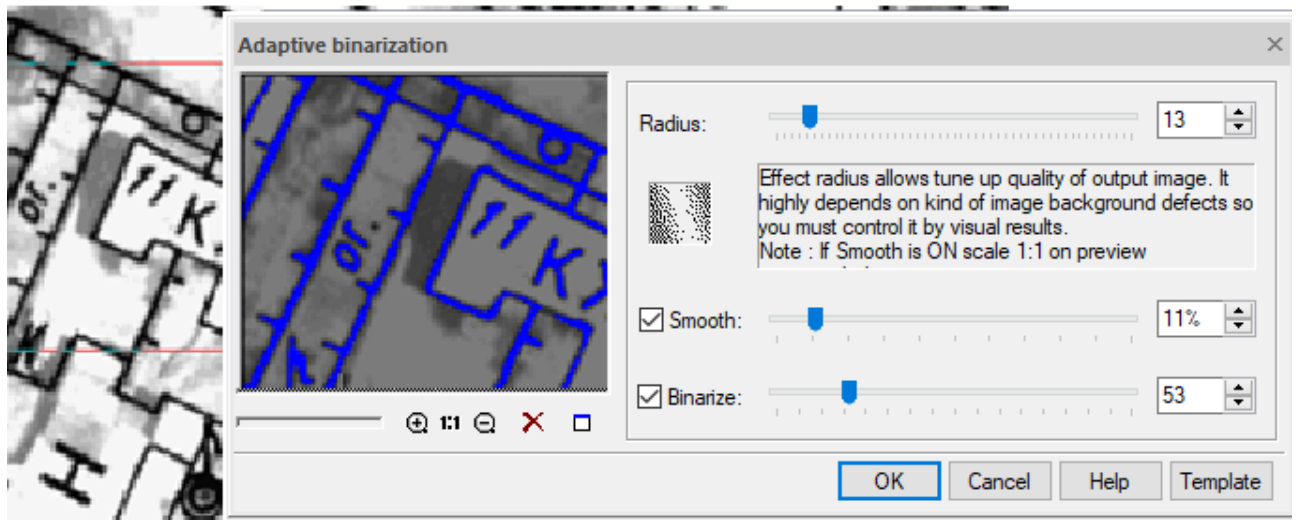

**Smooth** – smooths the background and makes the image objects more distinct, and removes “garbage” when performing binarization.

**Binarize** – creates a monochrome image of selected information.

When satisfactory results are achieved in the preview window, click the **Apply** button.



## Color Separation

-  Ribbon: **Raster – Processing >  Color Separation**
-  Menu: **Raster – Processing the raster >  Color Separation...**
-  Command line: **COLORSEPARATION**
-  This functionality is available only in the Raster module.

The operation allows you to separate points of a color image into disjoint sets – categories.

Each category is defined by a set of base colors. The purpose of such procedures is to highlight the colors by which the original image was made. Usually, objects of the same kind are indicated by one color, therefore, by dividing image points by color, you get the opportunity to select the necessary image objects into separate monochrome raster layers (images).

The example shows the creation of monochrome background layers, rivers and level lines using the procedure of separation by color.

1. Run the command.
2. Create a set of categories using the **Add category** button:

Use the eyedropper to indicate an object on the image, the points of which should fall into the category being created.

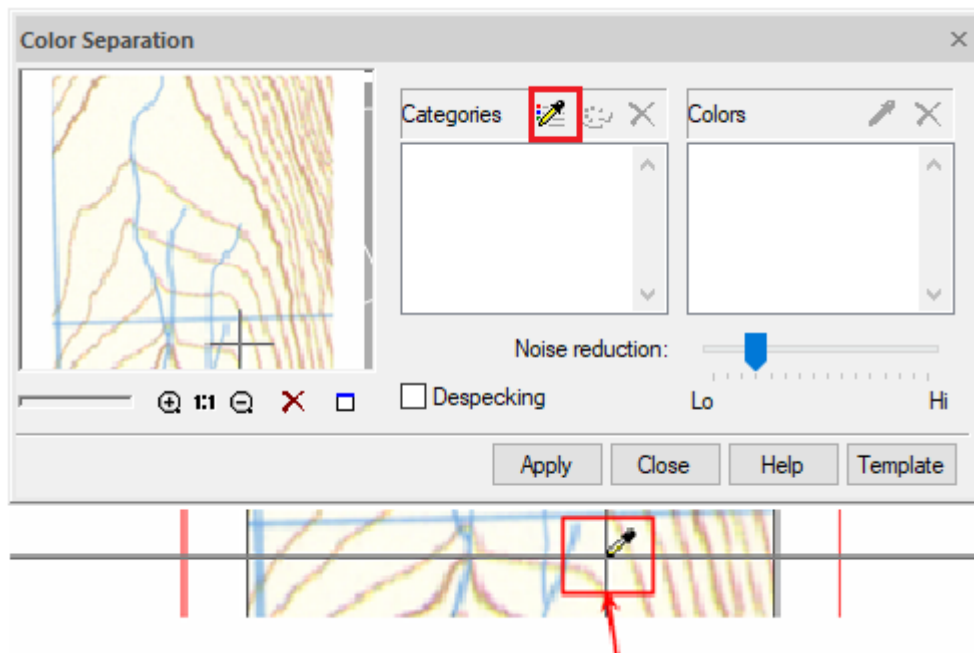

specify point on the background

On the screen the **Category Name and Color** window will appear, in which you can assign a symbolic color and a category name.

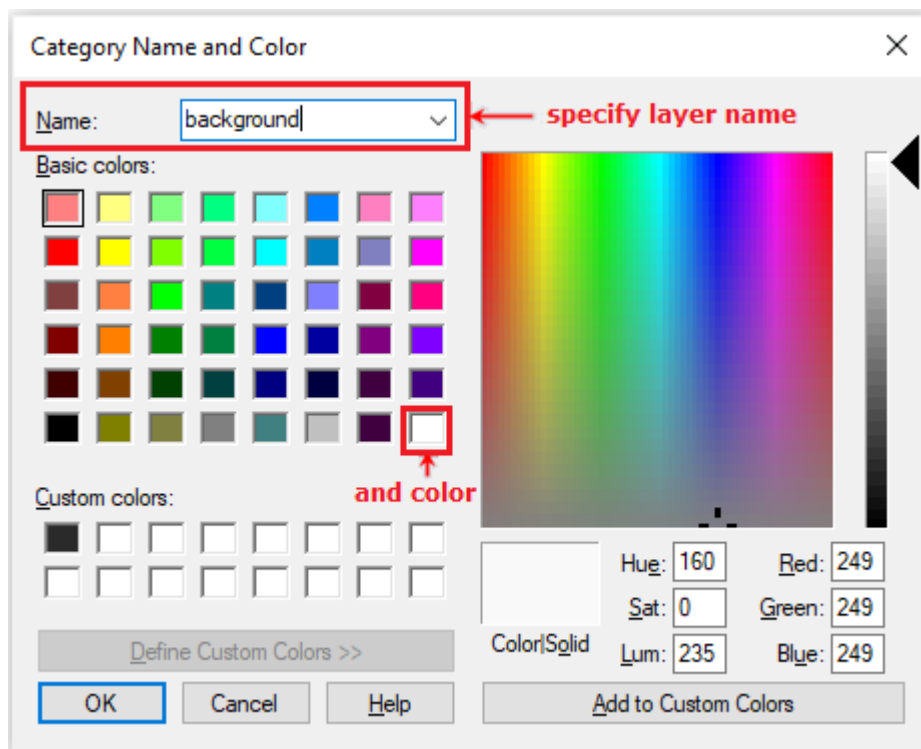

3. In the same way, use the eyedropper to indicate the level lines. Specify the layer name – **Level lines** and select the color – **dark brown**.
4. Add basis colors to the **Level lines** category. Click the eyedropper button in the **Colors** field and specify point on the image. The color of the specified point will be added to the list of the **Colors** field.



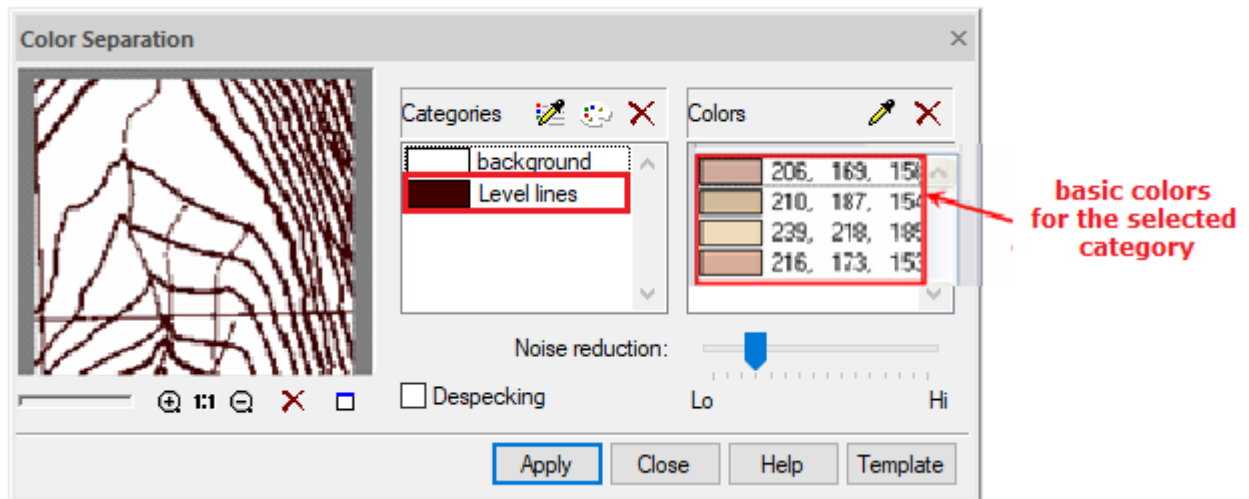

In case of an error when choosing a basic color, delete it. The error in the color selection is determined by the separation results, which are dynamically displayed in the preview window.

5. In the same way, create a category for rivers and set the basic colors.

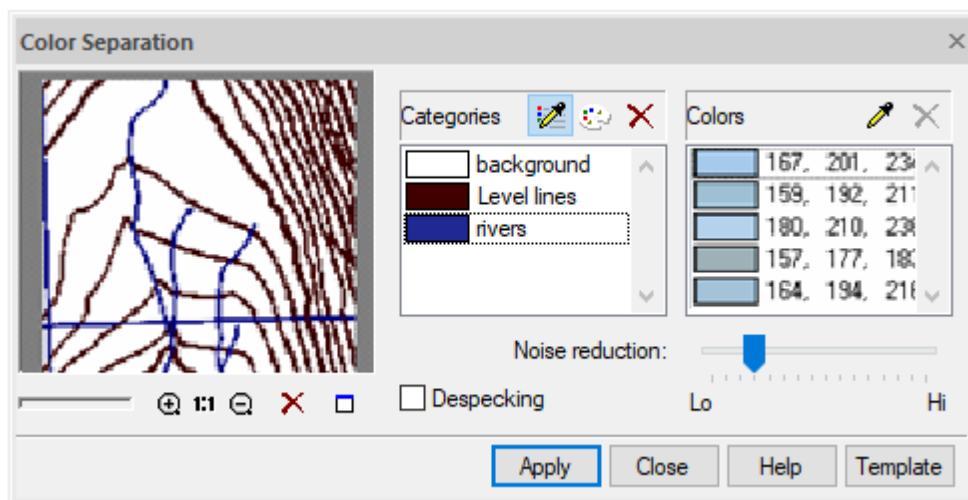

6. To process a larger number of images of the same type, it is convenient to save the color separation parameters in a special file. Select the **Template** button and save the setting in the template. The saved setting can be later loaded to work with another image.
7. Having achieved an acceptable separation quality, click the **Apply** button.

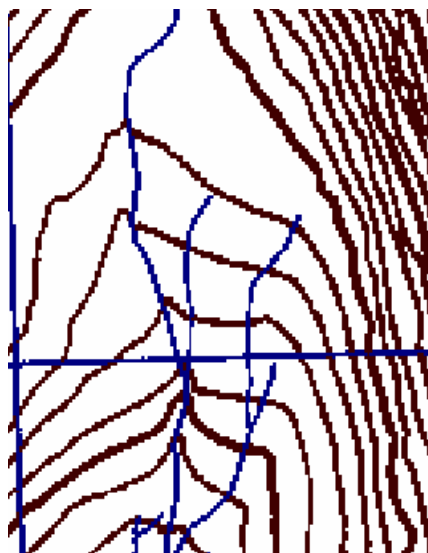

## Color Reduction

 Ribbon: **Raster – Processing** >  **Color Reduction**

 Menu: **Raster – Processing the raster** >  **Color Reduction...**

 Command line: **COLORREDUCTION**

 This functionality is available only in the Raster module.

The procedure for reducing the number of colors is the same as for separating by color described in the previous section. The only difference is that you do not need to define the category names, since the procedure for reducing the number of colors does not create additional layers.

The procedure is set up in the same way as in the separation procedure. The purpose and functions of elements of this dialog box are identical to the purpose and functions of the elements in the **Color Separation** dialog box.

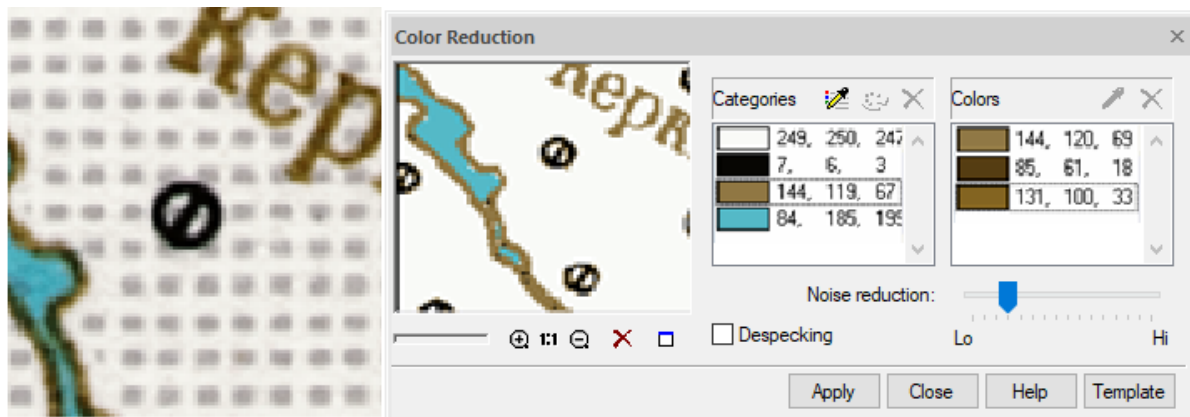

## Monochrome Filtering

 This functionality is available only in the Raster module.

Monochrome filters are used to process monochrome (black and white) images. Monochrome images are also called bitonal because they only use one bit of information to describe the color of each pixel (black or white).

Filtering operations can be applied to images located on visible and unlocked layers. One or several raster images can be filtered.

## Removing “Speckle”

 Ribbon: **Raster – Filters** >  **Speckle Remover**

 Menu: **Raster – Filters** >  **Speckle Remover...**

 Command line: **SPECKLEREMOVER**

 This functionality is available only in the Raster module.

The filter removes raster objects (isolated groups of pixels), the size of which is less than the specified value, and automatically estimates the size of spots in the image. This filter can be

used after binarization or separation procedures to remove small raster objects from the resulting monochrome layer images.



**Fragment of a monochrome raster obtained as a result of binarization**



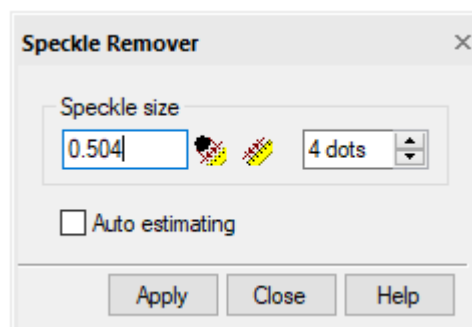

**After "speckle" removal**

1. Select images to be processed and run the  **Speckle Remover** command.



2. Enter the maximum size of raster objects to be deleted in the current units (left input field) or in points (right input field).
3. Or check the **Auto estimating** box to let the filter estimate the size of the raster "speckle" before filtering.

To measure the size of a raster object on the screen, click  button and specify a point inside the object, or click  button and specify two points on the screen. The program will set the "speckle" size equal to the distance between the specified points.

4. Click **Apply**.

## Filling "Holes"



Ribbon: **Raster – Filters** >  **Hole Remover**



Menu: **Raster – Filters** >  **Hole Remover...**



Command line: **HOLEREMOVER**



This functionality is available only in the Raster module.

The filter fills small holes in raster objects. In this case, only those “holes” are filled, the size of which is less than the specified value. This filter can automatically estimate the size of holes in image objects.

The filter can be used after binarization or separation procedures to fill in unwanted holes in raster objects.



Original image



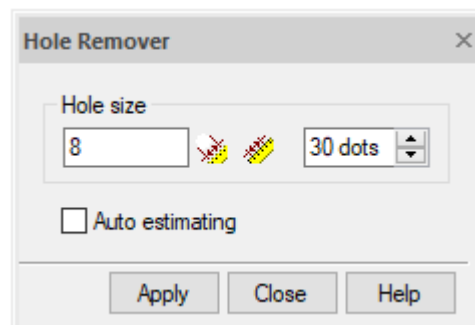

After removing “holes”

1. Select images to be processed and run the  **Hole Remover** command.



2. Enter the maximum size of the raster “holes” to be removed in the current units (left input field) or in points (right input field).
3. Or check the **Auto estimating** box to let the filter automatically estimate the size of raster “holes” before filtering.

To measure the size of the raster “hole” on the screen, click  button and specify a point inside the “hole”, or click  button and specify two points on the screen. The program will set the “hole” size equal to the distance between the specified points.

4. Click **Apply**.

## Smoothing



Ribbon: **Raster – Filters** >  **Smoothing**



Menu: **Raster – Filters** >  **Smoothing...**



Command line: **SMOOTHER (SMOOTHING)**



This functionality is available only in the Raster module.

The filter smooths outlines of raster objects, fills in edge and internal background speckles, and also partially removes raster “garbage”.



**Fragment of the original image**



**After smoothing**

Work of the **Smoothing** filter consists of two stages. At the first stage it works like the **Median** filter on a grayscale image, analyzes the neighborhood of a given radius of each pixel and replaces the brightness of the central pixel with the average brightness of the neighborhood. As a result, the outlines of the raster object are blurred. Increasing the **Medianning** value makes gray strips wider.

At the second stage, the filter converts to black those pixels whose brightness value is less than the value of the **Threshold** parameter. Wide black lines show the binarization boundaries. Pixels inside boundaries turn black, outer pixels turn white. Increasing the **Threshold** value makes the objects thicker, while decreasing makes them thinner.



**First stage – blurring edges**

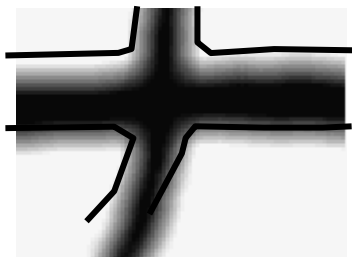

**Second stage - binarization**

1. Select images to be processed and run the  **Smoothing** command.
2. Set the **Medianning** – the degree of medianning in percent. This value determines the degree of blurring the outlines of raster objects.

3. Set the **Threshold** – gray level from 0 to 255. This value determines the degree of cropping of blurred edges. Higher values increase the amount of smoothing, but the raster lines get thicker.

Use the preview window to select the optimal values of the parameters.

4. Click **OK**.

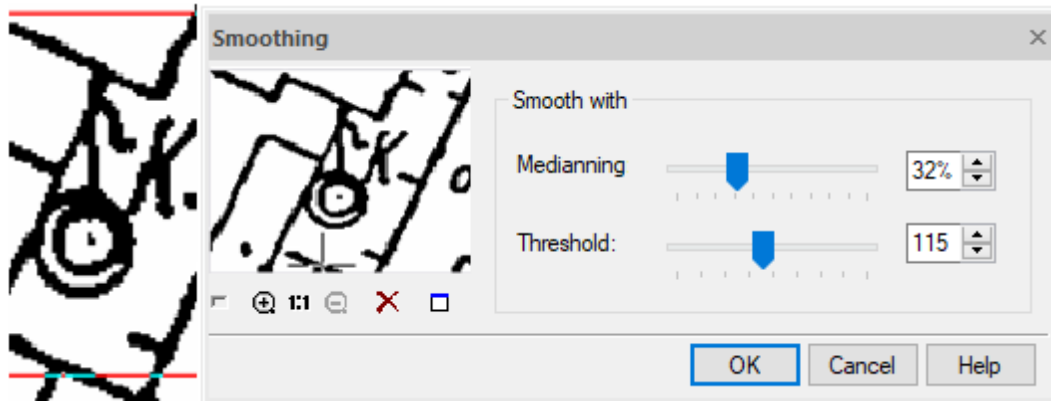

## Thinning



Ribbon: **Raster – Filters** >  **Thinning**



Menu: **Raster – Filters** >  **Thinning...**



Command line: **THINNING**



This functionality is available only in the Raster module.

The filter in one pass thins raster fragments by one point (pixel) simultaneously in all directions. This filter has an additional parameter that allows you to thin raster objects to the skeleton (only the pixels located in the middle remain).

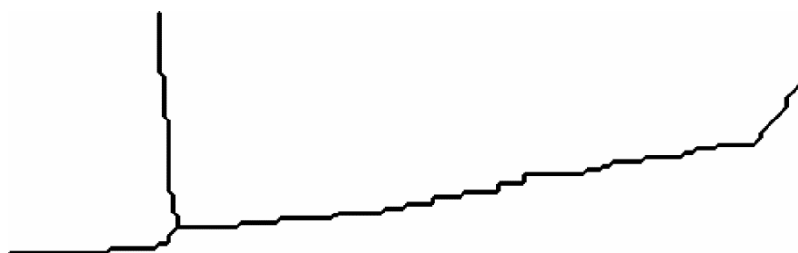

**After thinning to skeleton**

Select images to be processed and run the command.

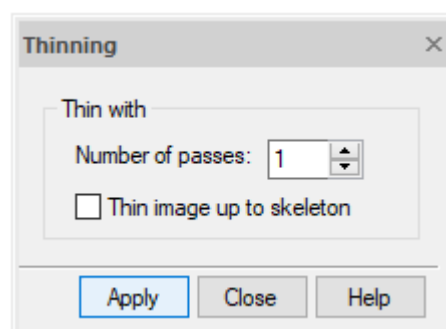

Specify the number of filter passes, or select **Thin image up to skeleton** to turn all objects into one-pixel lines.

Click **Apply**.

## Thickening

 Ribbon: **Raster – Filters >  Thickening**

 Menu: **Raster – Filters >  Thickening...**

 Command line: **THICKER**

 This functionality is available only in the Raster module.

This filter thickens raster objects by a specified number of pixels in a specified direction - horizontal, vertical, or simultaneously in all directions.

The pictures below show how thickening works when all directions are selected. On the left there is the original raster image, and on the right there is the result of applying the filter after three passes.



**Thickening filtration in all directions**

The figure below illustrates how the **Thickening** filter works when only the vertical direction of the thickening is selected. On the left there is the original raster image, on the right there is the result of applying the **Thickening** filter after three passes.



**Vertical thickening filtration**

Select the images to be processed and run the command.

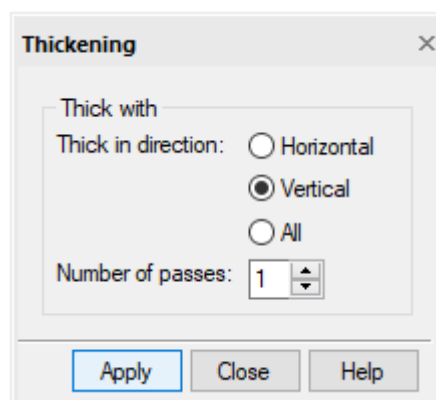

Select the required direction of thickening – **Horizontal**, **Vertical** or **All** (horizontal, vertical or diagonal).

Click **Apply**.

## Contour

 Ribbon: **Raster – Filters** >  **4 Connected Contour**

 Ribbon: **Raster – Filters** >  **8 Connected Contour**

 Menu: **Raster – Filters – Contour** >  **4-coupling**

 Menu: **Raster – Filters – Contour** >  **8-coupling**

 Command line: **CONTOUR4**

 Command line: **CONTOUR8**

 This functionality is available only in the Raster module.

Contour filters turn filled raster areas into single-pixel contours. In a four-connected contour, adjacent pixels can only be joined by the sides, in an eight-connected contour, contiguity is also allowed at the corners, so such contours look thinner.

The images below show the results of applying contour filters.

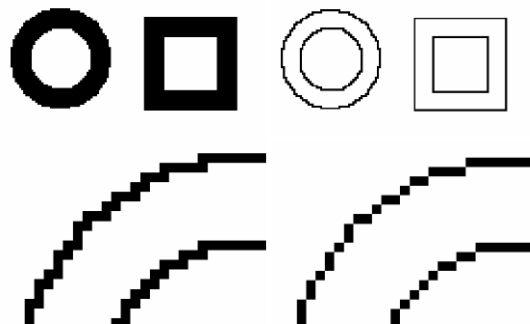

**Parts of contours obtained with four-connected and eight-connected filtering**

Select the images to be processed and run the command.

## Inversion

 Ribbon: **Raster – Filters** >  **Inversion**

 Menu: **Raster – Filters** >  **Inversion...**

 Command line: **INVERSION**

 This functionality is available only in the Raster module.

Inversion changes the color value of each point of a monochrome image to the opposite (creates a “negative image”). The background points become the image points, and the points transmitting the image of the objects - the background ones. The figure below shows the result of applying the filter.





**Result of applying the Inversion filter**

Select the images to be processed and run the command.

## Selection of Data in Raster Images



This functionality is available only in the Raster module.

To edit the content of monochrome raster images, apply the raster selection. Using various types of selection, you can select on raster images:

- *raster objects* – raster lines, arcs and circles;
- *areal fragments of a raster image*;
- *raster lines segments* – fragments of raster lines of any shape limited by points of intersection with other raster lines or endpoints;
- *isolated raster fragments* – multiple interconnected raster points.

## The Order of Raster Selection

- set the selection mode: add data to selection, remove from selection, single selection;
- run one of the selection methods: specifying, within the rectangle, clipping polygon, etc. The selection method is assigned based on the type of raster data being selected;
- carry out the procedure for pointing on the image in accordance with the running method.





## Quantitative Raster Selection Modes



Ribbon: **Raster – Raster Selection – Basic methods > ...**









Menu: **Raster – Raster Select > ...**

Button	Mode	Action
	Single	Each new selection cancels the previous selection
	Remove	The selected data are excluded from the existing selection.
	Add	New raster data are added to the selection set.
	Select All	The content of all raster images is selected.
	UnSelect All	All data are unselected.

## Basic Selection Modes



 Ribbon: **Raster – Raster Selection > ...**



 Menu: **Raster – Raster Selection > ...**

Button	Method name	Specifying procedure	Selected raster data
	Select Auto	Specify the object.	Raster object.
	Select by rectangle (rectangular area)	Specify opposite corners of rectangular area.	All raster data inside the rectangular area. The selection border runs exactly along the edge of the rectangular selection box.
	Select by polygon (polygonal area)	Specify points that determine the boundary of a polygonal area that completely covers the selected data. Press <b>ENTER</b> .	All raster data are polygon-bound. The selection border runs exactly along the edge of the polygonal selection box.
	Select Raster Line	Specify two points - the ends of the reference line.	Raster line below the reference line
	Select Raster Arc	Set three points - start, arbitrary midpoint, and end point of the reference arc.	Raster arc below the reference arc.
	Select Raster Circle	Specify two points - the ends of the reference circle diameter.	Raster circle below the reference circle.
	Select Raster Flood Fill	Specify any point on a raster object	Parts of an image whose raster points touch each other. This is useful for selecting isolated raster objects.

## Object Raster Selection Methods





The trace selection of raster data is based on the principle of recognition of individual raster objects: raster lines, arcs and circles in the selected area or on its border.

	Inside window	Specify opposite corners of the rectangular area.	Objects that are completely within the rectangle. Raster objects crossed by the rectangle border are not selected.
	Inside polygon	Specify points that determine the boundary of the polygonal area.	Objects that are completely inside the polygon. Raster objects

		Press <b>ENTER</b> .	crossed by the polygon border are not selected.
	Cross window	Specify opposite corners of the rectangular area.	Objects that are inside the region, as well as all raster objects crossed by the rectangle border.
	Cross polygon	Specify points that determine the boundary of the polygonal area. Press <b>ENTER</b> .	Objects that are inside the polygon, as well as all raster objects crossed by the polygon boundary.
	Fence	Specify a set of points – polyline vertices. Press <b>ENTER</b> .	Raster objects crossed by the specified line.





## Trace Selection Methods.

Trace selection of raster data is based on the principle of recognizing raster line segments in a given area or before crossing with other segments.

Button	Method name	Specifying procedure	Selected raster data
	Inside window (trace)	Specify opposite corners of the rectangular area.	Objects that are completely within the area before crossing with other segments. Raster objects crossed by the rectangle border are not selected.
	Inside polygon (trace)	Specify points that determine the boundary of the polygonal area. Press <b>ENTER</b> .	Objects that are completely inside the polygon before crossing with other segments. Raster objects crossed by the polygon border are not selected.
	Cross window (trace)	Specify opposite corners of the rectangular area.	Objects that are inside the region and crossed by the rectangular border before crossing with other segments.
	Cross polygon (trace)	Specify points that determine the boundary of the polygonal area. Press <b>ENTER</b> .	Objects that are inside the polygon and crossed by the polygon boundary before crossing with other segments.
	Fence (trace)	Specify a set of points – polyline vertices. Press <b>ENTER</b> .	Raster objects crossed by the specified line before crossing with other segments

## Fill Selection Methods

The fill selection of raster data is based on the principle of recognition in a given area of contacting (merging) raster points.

Button	Method name	Specifying procedure	Selected raster data
	Inside window (fill)	Specify opposite corners of the rectangular area.	Objects that have contacting pixels and are completely within the rectangle.
	Inside polygon (fill)	Specify points that determine the boundary of the polygonal area. Press <b>ENTER</b> .	Objects that have contacting pixels and are completely within the polygon.
	Cross window (fill)	Specify opposite corners of the rectangular area.	Objects inside the area, crossed by the rectangle border and all contacting areas.
	Cross polygon (fill)	Specify points that determine the boundary of the polygonal area. Press <b>ENTER</b> .	Objects inside the polygon and crossed by the polygon border and all contacting areas.
	Fence (fill)	Specify a set of points – polyline vertices. Press <b>ENTER</b> .	Raster objects crossed by the specified line and all contacting ones.

## Setting Selection Options

For correct recognition of raster objects when using the object selection methods, it is necessary to make settings in the **Options** tab of the **Conversion options** dialog box:

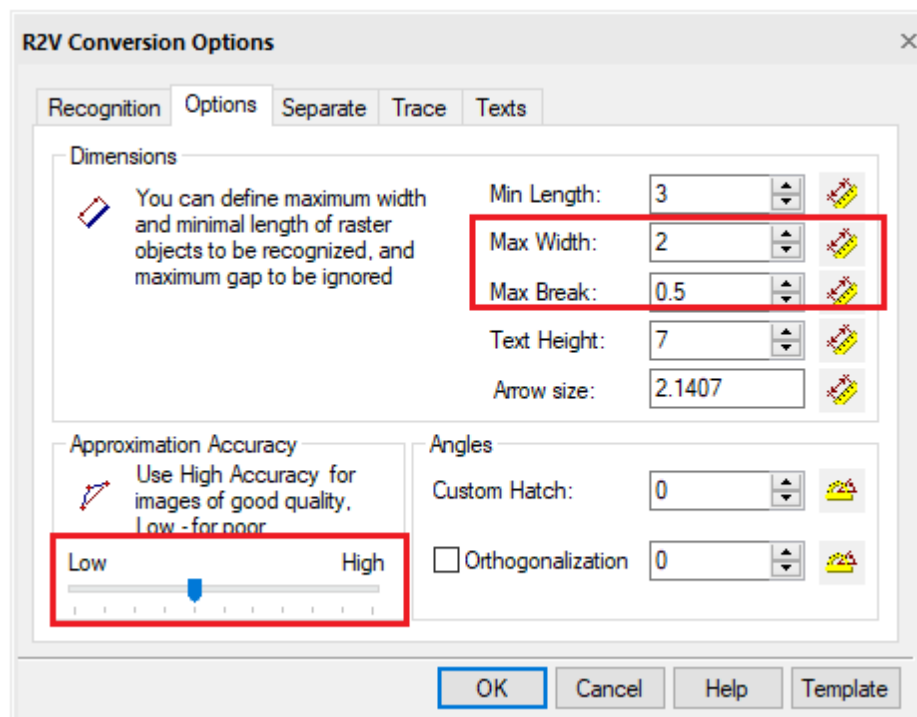

















### Selection options for recognizing raster objects

Option	Description
Max. width	The maximum thickness of raster objects that can be selected using object recognition or line-following methods. Lines that are thicker than the specified value will not be selected.
Max. break	The amount of the maximum ignored raster line break. If the raster line breaks are less than the specified value, the line will be selected as a single object.
Approximation Accuracy	When a raster is selected using methods based on object recognition, the Accuracy parameter sets the acceptable degree of deviation of the shape of raster entities from their vector prototypes.  If the original raster entities are distorted, for example, the raster circles are elliptical, the selection accuracy will increase as you move the Accuracy slider to the left. To make a selection on the original raster image of good quality, move the slider to the right.

The values of **Max. thickness** and **Max. break** parameters can be measured in a raster image using  buttons next to the fields.

## Separation by Type and Size

-  Ribbon: **Raster – Processing** >  **Separation by size**
-  Ribbon: **Raster – Processing** >  **Separation Linear Objects**
-  Ribbon: **Raster – Processing** >  **Separate Text Areas**
-  Menu: **Raster – Processing the raster** >  **Separation by size**
-  Menu: **Raster – Processing the raster** >  **Separation Linear Objects**
-  Menu: **Raster – Processing the raster** >  **Separate Text Areas**
-  Command line: **SEPARATIONBYSIZE**
-  Command line: **SEPARATELINEAROBJECTS**
-  Command line: **SEPARATETEXTAREAS**
-  This functionality is available only in the Raster module.

Selection operations allow you to transfer specific monochrome raster objects to new raster images placed on specified layers. From the original image, you can select hatches, text, linear objects and objects by size (isolated groups of adjacent points).



When performing an operation, the program finds objects of the specified type with the specified parameters in the image and transfers them to a new raster image. The new raster image created as a result of the operation has the same parameters (size, insertion point, resolution, scale) as the original one, but is placed on the specified layer. In this case, the loss of objects removed from the original image does not occur - they are simply moved to a separate raster layer.

The separation procedures can be used:

- instead of speckle remover, when it is necessary to save small-sized image objects, which the program can attribute to raster "garbage";
- when it is necessary to use operations only to objects of a certain type, for example, editing texts or hatches.

After making selection, the displaced objects can be saved as a separate raster image, selected and returned to the original image, or the entire resulting raster layer can be deleted.

### *The order of performing object separation operations*

- select the images to be processed. If no selection is made, the operation will be applied to all visible images located on unlocked layers;
- Run the appropriate command;
- In the dialog box that opens, configure the parameters by which the selection of objects will be carried out. The type and settings of the dialog box depend on the type of the selected object. The    buttons in the dialog boxes located next to the fields are designed to measure the set parameters in the image. To measure the object parameter in the image, click the button and indicate the required on the screen. The measured value appears in the corresponding field. The principle of filling in the **Output layer** field, in which it is necessary:
  - enter the name of the layer on which the created image with the selected objects will be placed;
  - set the color of the created layer by left-clicking on the color swatch located next to the field and choosing a color in the dialog box that appears.
- The settings results are controlled in the preview window of the dialog box. When satisfactory results are achieved, click **Apply**.

### *Setting parameters in the dialogs of object separation commands*

#### *Separation by size*

- set the minimum and maximum size of objects in the corresponding fields;
- select linear objects;
- in the **Max.width** field, set the value of thickness of the raster line of objects to be selected;
- in the **Max. break** field, specify the ignored break size in lines.

#### *Separate text areas*

- in the **Max.width** field, set the maximum line width of the raster text;
- in the **Text Height** field, specify the maximum size of an upper case letter in the text;
- in the **Text Orientation** field, select from the drop-down list the orientation of texts **Horizontal**, **Horizontal and Vertical** or **Arbitrary Oriented**;
- if necessary, check the boxes **Overlapped texts** and **Single Letters**.

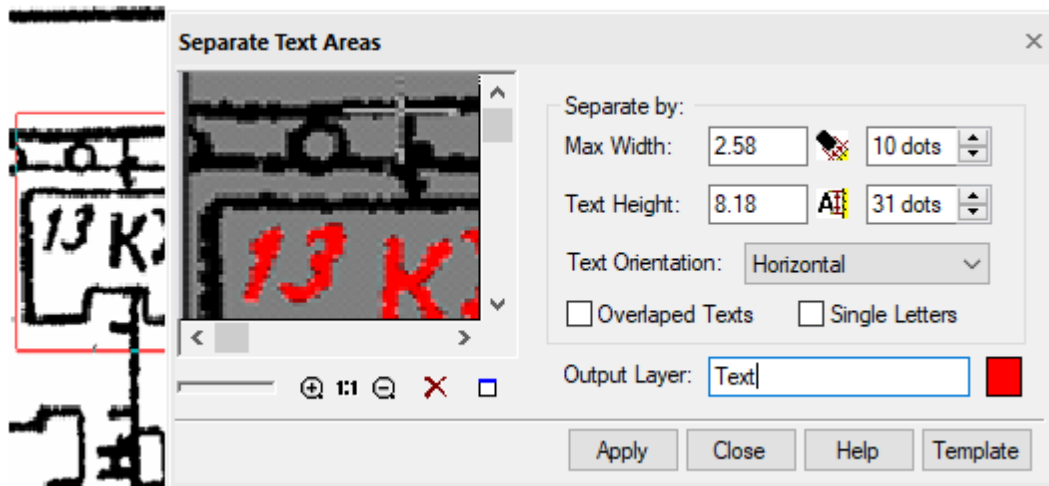

### *Saving and deleting the created raster image*

The created raster image with the selected objects automatically receives the status of embedded in the document and the name of the layer specified in the **Output layer** field.

## **Rasterization**

The following commands rasterize the selected vector and raster data onto underlying raster images. Selection can consist of:

- raster images;
- raster selection;
- vector data.

When these rasterization commands are executed, only the part of the selection that is located within the bounds of the underlying image is rasterized. The part of the selection outside the destination image bounds is ignored.

The commands will rasterize the selection to all underlying visible images located on unlocked layers.

## **Merge**

Add selected data to raster image.



Ribbon: **Raster – File >**  **Merge/Rasterize**



Menu: **Raster –**  **Merge (Rasterize)**



Toolbar: **Raster –** 



Command line: **MERGE**

1. Select data for rasterization.
2. Place it over the destination image.
3. Run the command **Merge**.

Source data will be deleted.

## Merge a Copy (Rasterize)

Add the copy of data to raster image and save original.



Ribbon: **Raster – File** >  **Merge a Copy/Rasterize**



Menu: **Raster –**  **Merge a Copy (Rasterize)**



Toolbar: **Raster –** 



Command line: **DUPLICATE**

1. Select data for rasterization.
2. Place it over the destination image.
3. Run the command **Merge a Copy (Rasterize)**.

Copy of selected data will be rasterized. Original data will be kept.

## Raster Drawing

With pixel-based painting tools, you can draw and erase raster lines on monochrome, grayscale, and color images. When working on a monochrome image, these tools allow you to paint images with the color or erase – that is, draw with the background color. When working on a color or grayscale image, you can choose the color (grayscale) that will be used for drawing.

The fill tools can work on both monochrome and color images and let you fill raster areas within closed contours with the color of raster objects and erase isolated raster objects by filling them with the color of the raster background.

### Pixel drawing

Tools for pixel drawing used for drawing and erasing raster data of an image.

#### To draw on raster image:



Ribbon: **Raster – Draw** >  **Pencil**



Menu: **Raster –**  **Pencil**



Toolbar: **Raster –** 



Command line: **PENCIL**

#### Options:

##### Color

Setting the color of the pencil. The option opens the **Select Color** dialog box.

The option is available only if the drawing contains color raster images.

On monochrome images, the raster line will be displayed in the main color.

On grayscale images - by one of the shades of gray that most closely matches the selected color in terms of brightness.

On color images - by the selected color.

#### Command prompts:

Current color <R: 255 G: 255 B: 255>







Shows current color and an option to



or [Color]:  
 Draw or input pencil width <1.00000>:  
  
 Draw curve on raster or "Enter" to finish:

change it.  
 Shows current width of a line. Can be changed with user input.  
 Draw a line.

**To erase on raster image:**

-  Ribbon: **Raster – Draw >**  **Eraser**
-  Menu: **Raster –**  **Eraser**
-  Toolbar: **Raster –** 
-  Command line: **RASTERERASER**

**Options:**

Color      Setting the color of the eraser. The option opens the **Select Color** dialog box. The option is available only if the drawing contains color raster images. On monochrome images, the raster line will be displayed in the main color. On grayscale images - by one of the shades of gray that most closely matches the selected color in terms of brightness. On color images - by the selected color.

**Command prompts:**

Current color <R: 255 G: 255 B: 255>  
 or [Color]:      Shows current color and an option to change it.

Draw or input eraser width <1.00000>:  
                          Shows current width of a line. Can be changed with user input.







Draw curve on raster or "Enter" to finish:  
                          Draw a line.

## Floodfilling

The floodfilling tools allows the filling of closed raster outlines with the raster object color (foreground) and also to erase isolated raster objects by filling them with the raster background color.







The commands only work on a monochrome raster image.

**To fill raster contour with flood:**

-  Ribbon: **Raster – Draw – Fill >**  **Flood Fill**
-  Menu: **Raster –**  **Flood Fill**
-  Toolbar: **Raster –** 
-  Command line: **WHITEFLOODFILL**



Specify a point within a closed outline on a monochrome raster image.

### To erase with flood:

-  Ribbon: **Raster – Draw – Fill >  Flood Erase**
-  Menu: **Raster –  Flood Erase**
-  Toolbar: **Raster – **
-  Command line: **BLACKFLOODFILL**

Specify any point in the isolated raster area to be erased.

## Editing Raster Text

-  Ribbon: **Raster – Rasterize >  Editing Raster Text**
-  Menu: **Raster – Rasterization >  Editing Raster Text**
-  Command line: **RTEXTEDITCMD**

 This functionality is available only in the Raster module

1. Run the command

In the image set a rectangular area above the text being edited. In the process of specifying the area, you can specify its parameters **Base point**, **Area angle** (coordinates of the second point) in the corresponding fields of **Options** window and the text rotation angle in the **Angle** field.

2. Specify text base point (bottom left corner of the text).
3. Specify text base line.
4. Draw a rectangle around the raster text, the content of which will be removed from the raster.



5. Enter a text line in the command line or edit the recognized one, if text recognition is enabled.
6. Select the text insertion or rasterization mode.

## Digitizing Raster Data (Vectorization)

 This functionality is available only in the Raster module

- Trace (semi-automatic vectorization);
- Automatic vectorization.

## Trace (Semi-Automatic Vectorization)



This functionality is available only in the Raster module

Tracing is an interactive procedure that allows you to vectorize a raster. Tracing is based on the technology of local recognition of raster geometric entities. Using this technology, the program identifies raster lines as a line, arc or circle and generates the corresponding vector objects. You specify raster on the image, and the program creates vector objects that approximate the selected raster images. As a result of tracing, a vector copy of the raster object is created.

When tracing, you have the ability to transform and place only selected objects on different layers, as well as obtain vector objects with lineweights that depend on the width of the raster line.

Tracing is performed only on monochrome raster images.

The trace order:

- configure tracing parameters;
- select the tracing mode;
- select the method corresponding to the object being vectorized;
- specify object in the image.

### Configuring Trace

During tracing, local recognition of vector objects on a raster image occurs. For correct identification of objects, the program always uses two numerical parameters that determine the maximum width and value of the ignored raster line break, as well as the parameter that sets the degree of acceptable deviations of the shape of raster objects from vector prototypes.

Trace is configured in the [Conversion Options](#) dialog box, in the **Options** and **Trace** tabs.

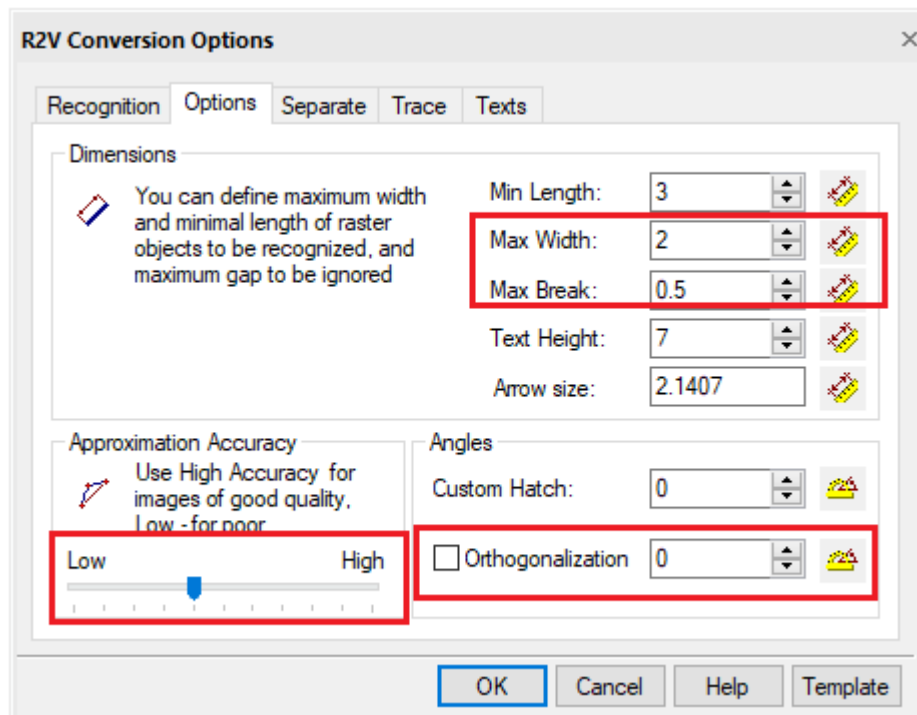

#### Best parameters when configuring trace

Set the values of parameters by entering them in the appropriate fields or measure them directly in the image by pressing the ruler button.

Click **OK**.

## Options tab





### Trace configuration options

Option	Description
Min.length	Minimum size of raster object, which is analyzed by recognition algorithm.
Max. Width	Sets the maximum width of raster lines, which can be approximated by lines, arcs, circles. If the width of a raster line exceeds the Max. Width value, trace is possible only in the Auto mode with approximation by a boundary object.
Max. Break	Specifies the length of the maximum ignored break of raster lines. If the raster line is split into several parts in the image, and you need to trace this line as a single object, set the Max. break slightly larger than the maximum spacing between parts of a raster line. The program will remove the gaps and create one vector object that approximates the entire raster line.  By setting a sufficiently large value of the parameter, you can, for example, trace dash-dot raster lines, arcs and circles as a whole. Values of Max. thickness and Max. Break can be entered from the keyboard or measured on the screen.
Accuracy	This parameter determines the accuracy of approximating the original raster object with a vector one. If the original image is distorted (for example, circles have the shape of an ellipse), then the value of the Accuracy parameter should be decreased. In this case, however, recognition inaccuracies may arise - for example, the program may take a short arc as a segment.  Applying a smoothing filter before tracing improves the quality of the raster image. If the quality of the raster image is good, the value of the Accuracy parameter can be increased.
Orthogonalization	When this box is checked, tracing in Auto and Line modes aligns the created lines perpendicular or parallel to the base direction, if the object deviation from these directions is insignificant. The base direction is set in the parameter field.  Enter the angle determining the base direction of orthogonalization - or - click the button and specify two points in the image - the value of the angle between the lines connecting these points and the direction of the X axis will be shown in the field. The value of the acceptable deviation is determined automatically by the Accuracy parameter value.

## Trace Modes

While *trace methods* determine how to recognize objects in the raster and which objects to recognize, the *trace mode* determines the final result of tracing – what should be the output.

The trace result can be:

- Creating vector objects ( **Make Vector and Keep Raster**),
- Deleting raster objects when creating vector ones ( **Make Vector and Erase Raster**),
- Deleting raster objects ( **Erase Raster**),
- Smoothing raster objects ( **Smooth Raster**).

The trace mode remains active till you choose another mode.

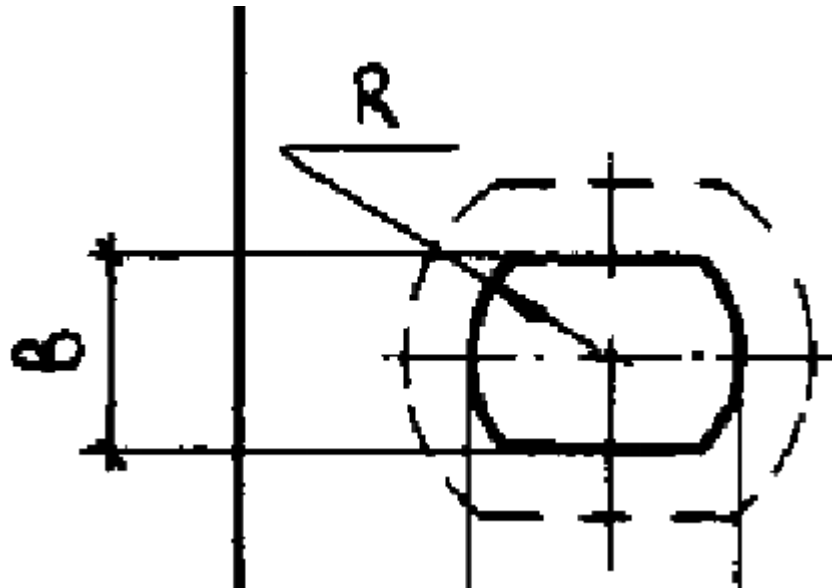

### Make Vector



Ribbon: **Raster – Trace – Mode** >  **Make Vector and Keep Raster**



Menu: **Raster – Trace** >  **Vector (keep raster)**



Command line: **MAKEVEKTORANDKEEPRASTER**

This mode creates vector objects while saving the original raster – the raster image is vectorized. The **Make Vector and Keep Raster** trace mode is used by default.

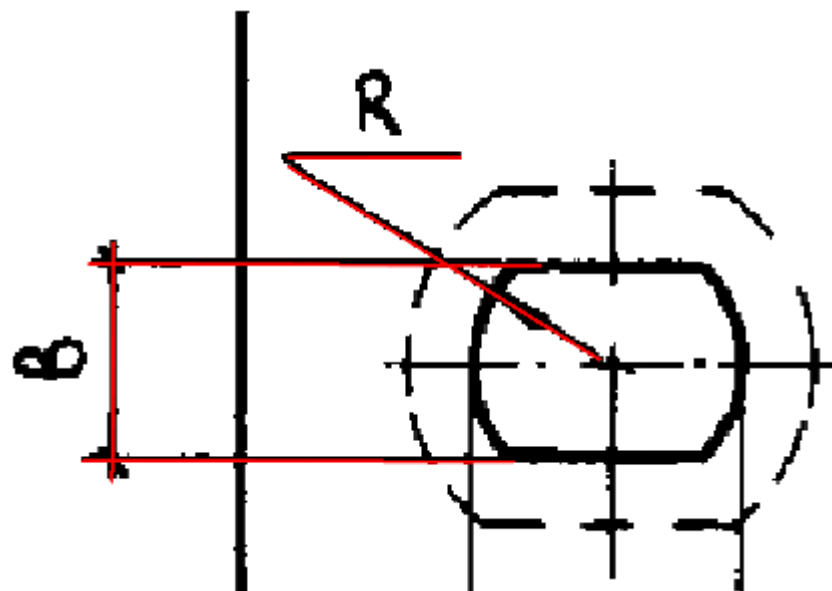

### Make vector and erase raster



Ribbon: **Raster – Trace – Mode** >  **Make Vector and Erase Raster**



Menu: **Raster – Trace** >  **Vector (erase raster)**



Command line: **MAKEVEKTORANDERASERASTER**

In this mode trace creates approximating vector objects and deletes the traced parts of raster lines. The mode converts raster objects into vector ones.

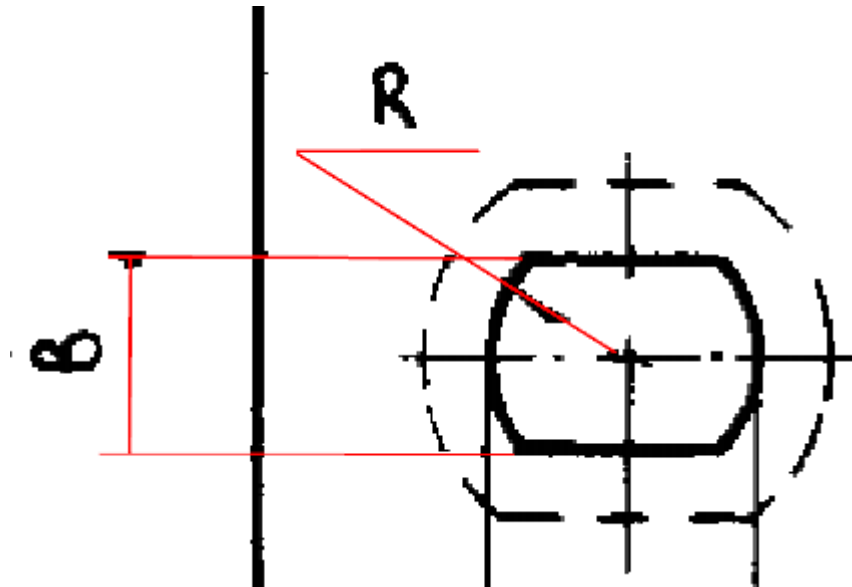

### Erase raster

 Ribbon: **Raster – Trace – Mode** >  **Erase Raster**

 Manu: **Raster – Trace** >  **Erase Raster**

 Command line: **ERASERASTER**

In this mode trace removes the traced parts of the raster line and does not create vectors. Intersections or parts of other raster objects under the traced data remain unchanged.

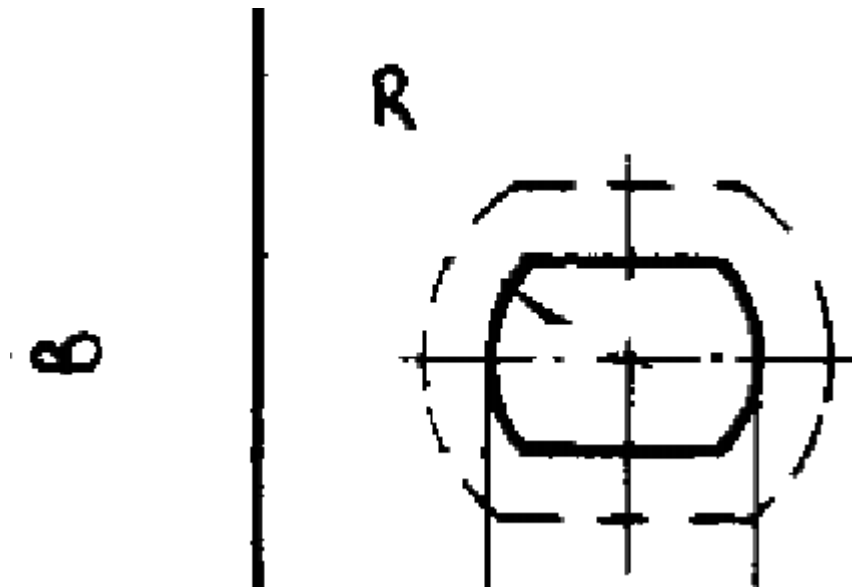

### Smooth raster

 Ribbon: **Raster – Trace – Mode** >  **Smooth Raster**

 Menu: **Raster – Trace** >  **Smooth Raster**

 Command line: **SMOOTHRASTER**

In this mode trace smooths raster lines.

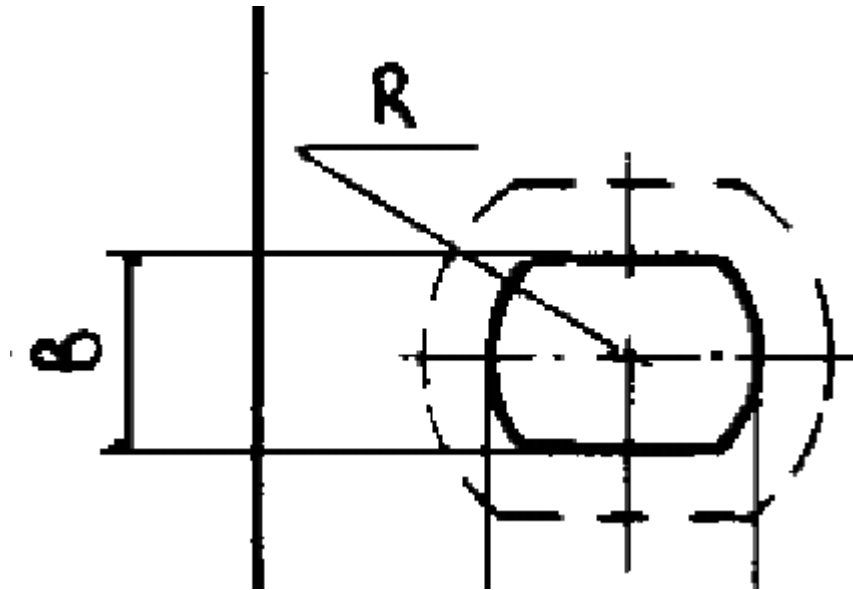

## Trace Methods

The trace method is determined by the type of vector object used to approximate the raster line. You can trace objects using automatic detection or indication of the object type.

### Trace with Automatic Detection of Object Type



Ribbon: **Raster – Trace – Trace** >  **Trace Auto**



Menu: **Raster – Trace** >  **Trace Auto**



Command line: **TRACEAUTO**



This functionality is available only in the Raster module

This method is used for tracing raster entities: line segments, arcs and circles.

*Raster entities* are raster objects that coincide in shape with basic vector objects – vector image entities (lines, arcs, circles). We will use the terms of *raster circle*, *raster arc* and *raster line* to mean circular, arc and line-shaped raster objects. Raster entities can also be defined as objects obtained by rasterizing the corresponding vector analogs, which happens, for example, when a vector drawing is output to a printer. It should be borne in mind that real raster entities may have defects that make it difficult to identify them by the program, for example, breaks, elliptical circles and arcs, uneven width, etc.

When tracing with automatic object detection, after specifying a point on the raster line, the program selects the type of vector object most suitable for approximating the specified raster line (line, arc or circle) and traces the specified raster object. If this object cannot be approximated by any of the above objects and its width exceeds the value set in the **Max. thickness** field of the **Options** tab, the program creates its vector contour, consisting of closed polylines.

When tracing a raster line by indication, the program determines the type of raster entity (line, arc or circle) and tries to trace the object as large as possible. In this case, the intersections of the entity with other objects are ignored and the set of points of the object is extended as long as the shape of the raster object corresponds to the recognized entity. Since real raster objects may differ from ideal raster entities, the recognition algorithm uses the **Accuracy** parameter, which sets the acceptable degree of mismatch between the shape of real raster objects and ideal ones.

### Trace with automatic detection of the object type

- Run the command;
- Click on the raster object to be traced.

The point should be selected on the least distorted and largest segment of the raster object, outside of its intersections with other objects.

If the program recognizes a raster entity, then it will be traced with the most suitable vector object.

If the specified object is not a raster line, arc, or circle, a vector contour approximating it will be created. The graphics editor distinguishes raster lines.

### Forced Trace



This functionality is available only in the Raster module

Forced tracing allows you to replace raster objects with vector ones of a specified type. The user selects one of the three object types (line, arc or circle) to be used as reference object for tracing (line, arc or circle), and then specifies points on a raster line, as if drawing a vector entity above the raster entity. The program tries to trace the specified object with a vector of the same shape. If possible, the raster line is traced. Unlike the **TraceAuto** command, these methods allow you to trace a part of a raster entity, as well as entities with significant shape distortions.

If the object width exceeds the value of **Max. thickness** parameter, or its shape cannot be approximated by the object of the specified type, then it is not traced.

When tracing by **Line** and **Arc** method, the ends (both or one of them) of reference lines and arcs can be specified outside the traced raster objects – on their imaginary continuation. In this case, the raster object is traced to its endpoints. If the ends of the reference objects lie on a raster object, then the part of the raster object located under the reference object is traced. If you want to recognize the line up to its finite limits, Check the **Auto-extend vectors** box in the **Trace** tab of the **R2V Conversion Options** dialog box.

#### Trace Line



Ribbon: **Raster – Trace – Trace >**  **Line**



Menu: **Raster – Trace >**  **Line**



Command line: **TRACELINE**

- Run the command;
- specify the beginning and end of the line lying on the raster object to be traced.

If the program cannot recognize the object under the vector line, a beep sounds.

#### Trace Arc



Ribbon: **Raster – Trace – Trace >**  **Arc**



Menu: **Raster – Trace >**  **Arc**



Command line: **TRACEARC**

- Run the command;
- Specify the first, middle and end points of the arc, lying on the raster arc to be traced.

To trace the next raster arc, repeat steps 1 and 2.



### Trace Circle

 Ribbon: **Raster – Trace – Trace >**  **Circle**

 menu: **Raster – Trace >**  **Circle**

 Command line: **TRACECIRCLE**

- Run the command;
- Specify two points – the ends of diameter of the raster circle to be traced.

To trace the next circle, repeat steps 1 and 2.

### Trace Outline

 Ribbon: **Raster – Trace – Trace >**  **Outline**

 Menu: **Raster – Trace >**  **Outline**

 Command line: **TRACEOUTLINE**





The **Trace outline** method is intended for tracing raster objects with closed boundaries. As a result of this operation, a closed polyline is created, it reproduces the object outline and the hatched area inside the outline.

To trace the outline:

- In the **Trace** tab of the **R2V Conversion Options** dialog box, set parameters for tracing outline with the selected method;
- Run the command;
- Specify a point inside the outline.

The outline trace results depend on the parameters set in the **Trace** tab of the **R2V Conversion Options** dialog box.

#### Trace options

Specified option	Trace result	View
Auto extend vectors – disabled	The vector is created along the border of two colors; the hatch type depends on the type selected in the <b>Options</b> tab	
Auto extend vectors – enabled	Creates a vector at the center of the raster line, taking into account its width; the line thickness is set in the <b>Options</b> tab	
Export single contour – disabled	Creates outer and inner contours based on raster data within the boundaries of the specified area	
Export single contour – enabled	Creates an outer contour only; raster data are ignored	

## Trace Polyline

 Ribbon: **Raster – Trace – Trace >**  **Line Following**

 Menu: **Raster – Trace >**  **LineFollowing**

 Command line: **LFCMD**

 This functionality is available only in the Raster module

The method belongs to the forced trace commands.

The method allows you to trace arbitrary raster lines, approximating them with a vector polyline. When tracing, specify a point on the raster line, and the command automatically follows this line (the tracing direction must be determined) to the nearest *node point* of the line or to *the intersection point* and creates an approximating vector polyline - a polyline consisting of linear segments. *The node point* of a raster line is either its endpoint or the point of intersection with another raster object. Thus, in one step, a part of an arbitrary raster line bounded by two node points is traced – *a raster polyline segment*. One trace step can create an arbitrary number of segments, the number of which depends on the line complexity and the trace settings.

After tracing each polyline segment, select the further direction of tracing or complete the procedure. Direction is selected by specifying a point on the next raster curve segment adjacent to the last traced segment. The steps and polyline segments can be undone.

The command provides for the mode in which the direction of continuing trace is determined automatically. In this mode, the program offers one of possible directions by showing a special marker on the segment selected as a continuation. Within a specified period of time (by default, the waiting time is 0), you can choose another direction or agree with the proposed one. If the direction is not selected, then after the waiting time has elapsed, the program will automatically continue tracing in the selected direction.

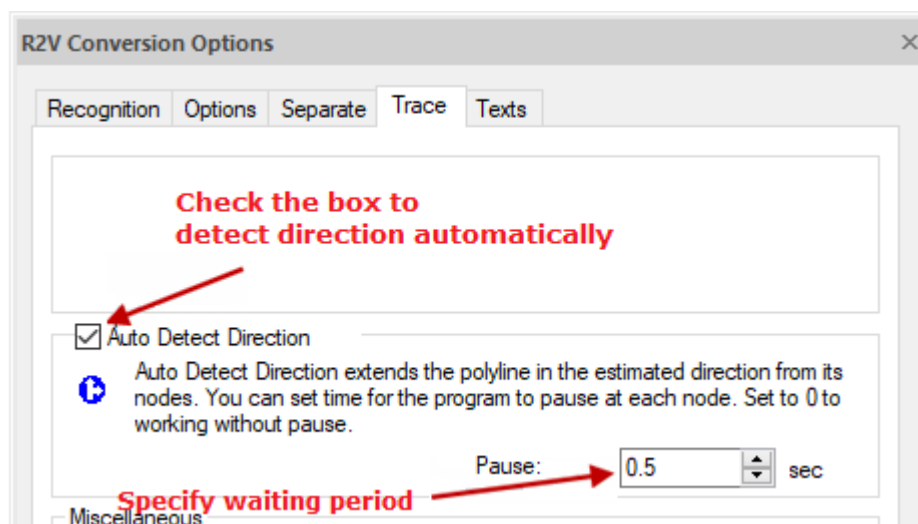

### Setting auto detect direction

The tracing of raster polylines is influenced by the parameters set in the **R2V Conversion Options** dialog box on the **Options** tab: **Max. thickness**, **Max. Break** and **Accuracy**, which specify the maximum thickness of the raster polyline, the size of the ignored break, and the accuracy of the raster polyline approximation.

The color and width of the polyline created by tracing depend on the checked **Use table** box and specified values of parameters in the **Separation** tab in the **R2V Conversion Options** dialog.

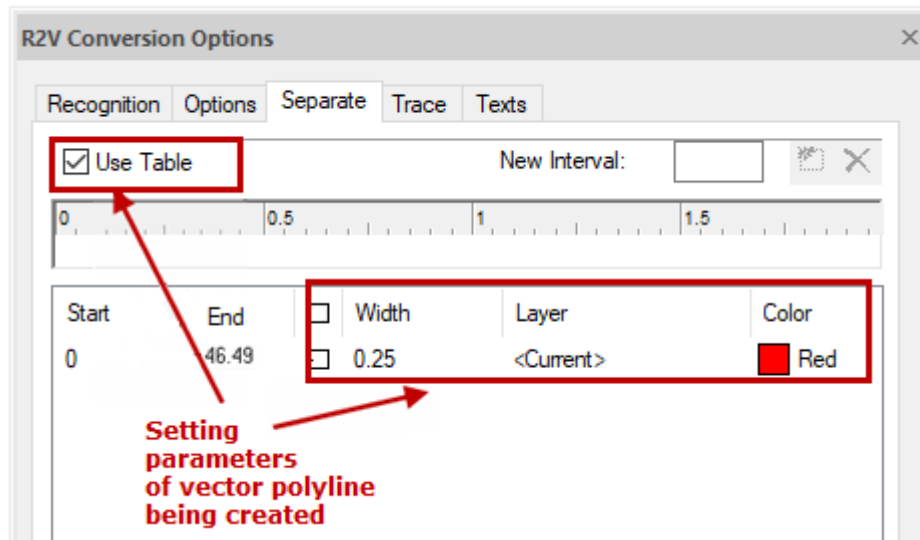

**Setting parameters of vector polyline being created**

**Context menu commands when tracing polyline**

Command	Description
Enter	Completes the polyline trace process and selects the polyline. The command continues.
Cancel	Stops the tracing process and cancels all work done. In addition, the tracing process is interrupted by pressing <b>ESC</b> .
BackStep	Undoes the last tracing step.
BackSegment	Undoes the last polyline segment.
Direction	Inverts the tracing direction.
DrawLine	Adds a line segment to a polyline without tracing. To add multiple segments, press <b>SHIFT</b> .
Center	Zooms the image to show the last added polyline vertex in the screen center.

**The order of tracing a polyline**

1. Set the command parameters in the **R2V Conversion Options** dialog box;
2. Specify the trace mode (**Make vector**, **Erase Raster** etc.);
3. Run the polyline trace command;
4. Pick points on the raster curve. When the **Auto Detect Direction** box is checked, a "rubber" line is drawn from the mouse cursor showing the current trace direction;
5. Manage the tracing process from the context menu;
6. To complete the polyline creation, select **Enter** or press **ENTER**;
7. To exit the command, press **ESC**.

**Tracing polyline with orthogonal segments**

When tracing raster polylines, you can use the orthogonalization mode, which allows you to align the generated polyline segments at a predefined *base angle*:

1. In the **R2V Conversion Options** dialog box, when tracing, check the **Line Follow Orthogonalization** box on the **Trace** tab;
2. Check the **Auto Estimate Base Angle** box or set the first segment direction in the **Base angle** field (or using  button measure it on the screen);

3. Decrease the **Accuracy** value in the **Options** tab to avoid creating superfluous segments;
4. Select the required trace mode and run the polyline trace command;
5. Specify the point on the screen to start the trace.

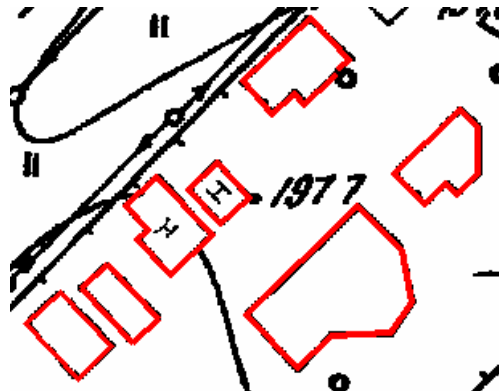

**Results of trace with orthogonalization**

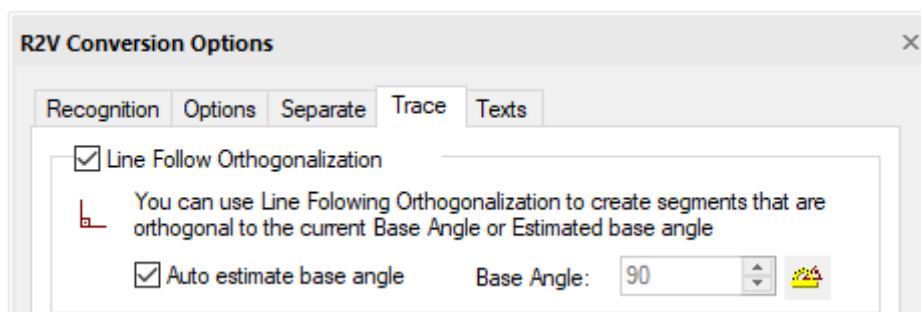



**Setting orthogonalization when tracing**

## ***Automatic Vectorization (Raster to Vectors)***

 Ribbon: **Raster – Conversion** >  **Raster to Vectors**

 Menu: **Raster – Convert** >  **Raster to vectors**

 Command line: **R2VCONVERTOR**

 This functionality is available only in the Raster module

As a result of automatic vectorization, vector objects are generated that approximate the raster image.

Vectorization can work on a raster selection set or on a group of images. If you have created a raster selection set and started vectorization, it will start to run on this set.

If there is no raster selection, and several images are inserted into the current drawing and they are available (visible and located on unlocked layers), then when performing vectorization, you need to select a group of raster images.

Vectorization also works on images that have a display border. Using this property, you can limit the vectorization area on any image by setting a cropping border for it.

Vector object thicknesses can be rounded to predefined values. Vector objects that correspond to raster lines of different thickness can be placed on different layers or assigned different colors.

The order of vectorization:

1. configure vectorization parameters (**R2V Conversion Options**);

2. select images to be converted;
3. start the automatic vectorization.

Vector objects appear above the source raster.

## Conversion Options



Ribbon: **Raster – Conversion** >  **R2V Conversion Options**



Menu: **Raster – Convert** >  **Conversion options**



Command line: **R2VSETUP**



This functionality is available only in the Raster module

Raster selection and vectorization are configured using the **R2V Conversion Options** dialog box. The main options are set in the **Recognition** and **Options** tabs. If text search and recognition algorithms used, then it is also necessary to configure options specified in the **Texts** tab described below in this chapter.

The thicknesses of the objects obtained during vectorization can be rounded to predefined values, as well as placed on different layers and assigned different colors. These operations are performed using the **Separate** tab.

### Recognition tab

In this tab you can select a set of algorithms that will be used when vectorizing a raster image.

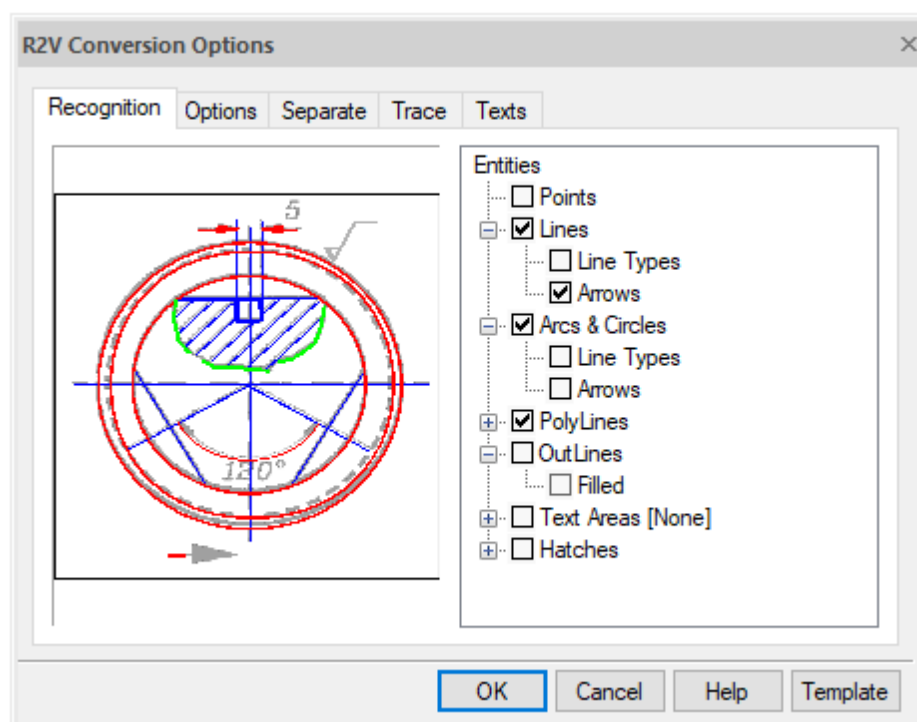

### Recognition tab

Different types of raster images should be vectorized using different sets of entities. For example, to vectorize images of maps or sketches, you should use polylines that approximate raster curves of arbitrary shape, and when vectorizing engineering drawings - algorithms that create segments, circles, arcs, then the vector drawing will most accurately reproduce the original drawing.

To ensure the possibility of optimal recognition of images of different structure, the Graphics Editor uses several vectorization algorithms that recognize raster analogs of vector entities and

generate approximating vector objects of the corresponding types. You can use one or more recognition algorithms in one vectorization operation.

The tree of algorithms is located in the right part of the **Recognition** tab. At the first level, there are recognition algorithms. To enable the desired algorithm, check the box next to its name. The second level of the tree contains additional functions and parameters of the corresponding algorithms.

The vectorization process is also directly influenced by the geometric recognition parameters located in the **Options** tab of this dialog box.

### Points

This algorithm is used to recognize geodetic marks and similar labels on specific images, for example, on geographic maps.

The graphics editor recognizes as a point an object with dimensions of at least 2x2 pixels (smaller objects are considered "speckle" and are deleted) and no more than the **Max. thickness** vertically and horizontally.

The **Point** type object can be recognized only in an automatic mode.

It is not recommended to use this algorithm when recognizing images of low quality or containing many small spots and "speckle".

### Lines

Includes line segment recognition algorithm. As a result of the algorithm work, straight lines are created.

The figure illustrates the results of vectorization using a single enabled **Lines** algorithm. The original raster fragment is shown on the left; the right drawing shows the result of vectorization with disabled display of object thicknesses.

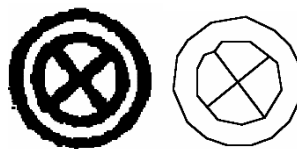

**Lines vectorization**

It has the following additional options:

- **Arrows** – when the option is enabled, it recognizes dash and dash-dot straight lines, creating vector lines with the corresponding line type;
- **Line Types** - when the option is enabled, it recognizes raster analogs of dimension lines (lines with one or two arrows at the end points) and, if the arrows are found, saves them as end markers of the line.

This algorithm is influenced by the following parameters of the **Options** tab.

The algorithm recognizes raster objects, the length of which is greater than the value of the **Min. length** option, and thickness is less than the value of the **Max. thickness** option.

The **Max. break** option sets the maximum length of an ignored raster line break.

The **Approximation Accuracy** option sets the accuracy of approximation of raster lines by vector objects. If the raster quality is poor, the option value should be decreased so that the algorithm recognizes raster objects with significant shape distortions.

When the **Orthogonalization** parameter is activated, the recognized line segments are aligned parallel and perpendicular to the direction specified in the **Base angle** field. Sections with small angles of deviation from the corresponding directions are aligned. The acceptable deviation for orthogonalization is determined by the **Accuracy** parameter. The closer this parameter is to the **Low** value, the greater the deviation can be.

### Arcs and circles

Enables the algorithm for recognizing raster circles and arcs.

The figure illustrates the results of vectorization using the **Lines** and **Arcs and Circles** algorithms. The original raster fragment is shown on the left; the right drawing shows the result of vectorization with disabled display of object thicknesses.

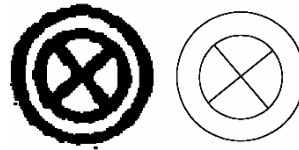

**Circle vectorization**

It has the following additional options:

- **Arrows** – when the option is enabled, the program searches for raster analogs of dimensional arcs (arcs with one or two arrows at the end points) and, if arrows are found, creates the corresponding dimensional objects;
- **Line Types** - when the option is enabled, the program recognizes dash and dash-dot arcs and circles, creating vector objects with the appropriate line type.

This algorithm is influenced by the following parameters of the **Options** tab.

The algorithm recognizes raster circles and arcs that are larger than the **Min. length**, and thickness is less than the value of **Max. thickness**.

The **Max. break** option sets the maximum length of an ignored raster arc and circle break.

The **Approximation Accuracy** option sets the accuracy of approximation of raster arcs and circles by vector objects. If the raster quality is poor, the option value should be decreased so that the algorithm recognizes raster objects with significant shape distortions.

### **Polylines**

This algorithm approximates the center lines of raster objects by polylines. The algorithm creates polylines consisting of straight segments only. You can use this algorithm alone or in conjunction with the **Outlines** algorithm when vectorizing maps and other images consisting of arbitrary lines (i.e., hand-drawn lines).

It has the following additional options:

- **Line Types** - when this option is enabled, the program recognizes dash and dash-dot arcs and circles, creating vector objects with the appropriate line type;
- **Create Vertex on Intersection** - when this option is enabled, the algorithm creates vertices at the intersections of polylines.

This algorithm is influenced by the following parameters of the **Options** tab.

**Max. length** determines the maximum length of the recognizable segment added to the polyline. Longer segments are not added to the polyline. This allows, for example, to trace curved contours on maps that intersect with coordinate lines; the algorithm automatically stops at the intersection of the traced contour with a long straight coordinate grid line.

Approximates raster lines that are thinner than the **Max. thickness**.

The **Max. break** option sets the maximum length of an ignored raster line break.

The **Approximation Accuracy** option sets the accuracy of the raster curve approximation by the vector polyline.

### **Outlines**

This algorithm is designed to approximate the outlines of filled areas by polylines by creating closed polylines that approximate the boundaries of raster objects. Contour polylines consist of straight segments only.

The figure shows the results of vectorization using the only enabled Outlines algorithm. The original raster fragment is shown on the left; on the right there is the result of vectorization.



### Outlines vectorization

This algorithm is influenced by the following parameters of the **Options** tab.

The algorithm approximates raster lines that are thicker than the **Max. thickness**. To get the outlines of all raster objects, enable only this algorithm and set the **Max. thickness** equal to zero.

The **Max. Break** option sets the maximum length of an ignored raster line break.

The **Approximation Accuracy** option sets the accuracy of approximating the raster object boundaries by vector polylines.

### Text areas

Enables the text recognition algorithm. The program finds image fragments containing raster texts and applies an operation specified as an additional parameter of the algorithm to the found texts.

The settings of search for raster texts and the OCR module are configured in the **Texts** tab of the same dialog box. The setting is described below in this chapter.

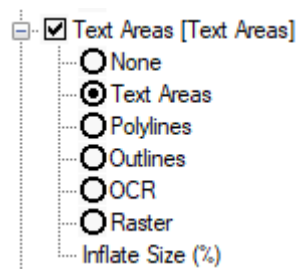

### Options of text areas vectorization

- **None** – does not vectorize raster texts. Areas containing found raster texts are not vectorized.
- **Text Areas** – creates vector rectangles that limit raster texts. Areas containing found raster texts are not vectorized. Vector texts can be entered manually using the procedure for viewing and correcting recognized texts described later in this chapter.
- **Polylines** – approximates the center lines of raster texts with polylines.
- **Outlines** – approximates the boundaries of raster texts with outline polylines.
- **OCR** – recognizes raster texts and creates text objects.
- **Raster** – recognizes raster texts without creating vector text objects.

The algorithm uses the values in the **Text Height** list of the **Options** tab as the maximum height of upper case raster text characters.

### Options tab

To optimally configure the raster entities recognition algorithms on a certain raster image, you can use information on measurement values of raster objects in the **Options** tab.



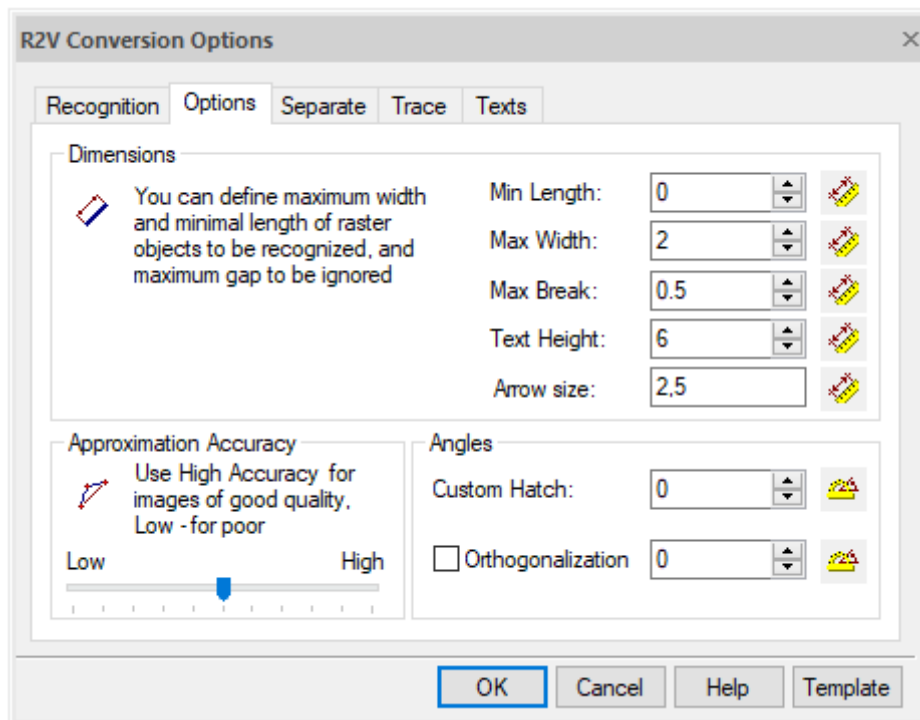



### Options tab

Options values can be entered from the keyboard or measured on the screen.

#### Measuring option value on the screen

Click the button located next to the corresponding dialog field (  or  ).

Specify two points in the image.

In the process of measurement, the program draws a “rubber” line connecting the specified points, therefore, in the text below the process of measurement in the image will be defined by the *draw a line* term. At the end of the measurement, the value is entered into the corresponding field.

#### Raster vectorization options

Option	Description
Min. Length	Specifies the minimum length of a raster fragment that should be recognized as a line, circle or arc during vectorization. Set the value of this parameter equal to the length of the shortest raster line or the diameter of the smallest raster circle (arc). When measuring in the image, draw a line along the smallest raster line, arc or circle. Min. Length value will be equal to the length of the drawn line.
Max. Thickness	Specifies the maximum thickness of a raster object that should be recognized as a line, arc or polyline. Set this value to slightly larger than the maximum thickness of the raster line to be vectorized using the Lines, Arcs and Circles or Polylines algorithms. If the program does not vectorize raster lines, circles, arcs of the image, increase the value of this option. If the program does not approximate filled raster areas with boundary objects, reduce the value of this option. When measuring distances in the image, the measurement (“rubber”) line should be drawn perpendicular to the thickest raster line, which should be recognized using Lines or Arcs algorithm or approximate using the Polylines algorithm. The measured value will be equal to the length of the part of the drawn line that passes along the raster line.
Max.	Specifies the maximum length acceptable for ignored raster lines break.

Option	Description
Break	If a line (arc) in the image is split into two parts, and you need to vectorize this line (arc) as a single vector object, set the option value, which exceeds the distance between these two parts. The break will be eliminated, and the parts of the vector line (arc) will be connected. When measuring in an image, draw a line along the largest break in the raster line (arc). This value will be equal to the length of the part of the drawn line that passes along the break.
Arrow size	Specifies the width and length of the object to be recognized as an arrow at the ends of the line. To determine the arrow dimensions, enter values in the field, separated by commas, or click the button and draw a rectangle that delimits the arrow.
Text height	Set this value equal to the maximum height of upper case raster text characters. When measuring in the image, draw a line over the raster text. The Text Height value will be equal to the distance between the first and last image points that fall on the drawn line.

### Separate Tab

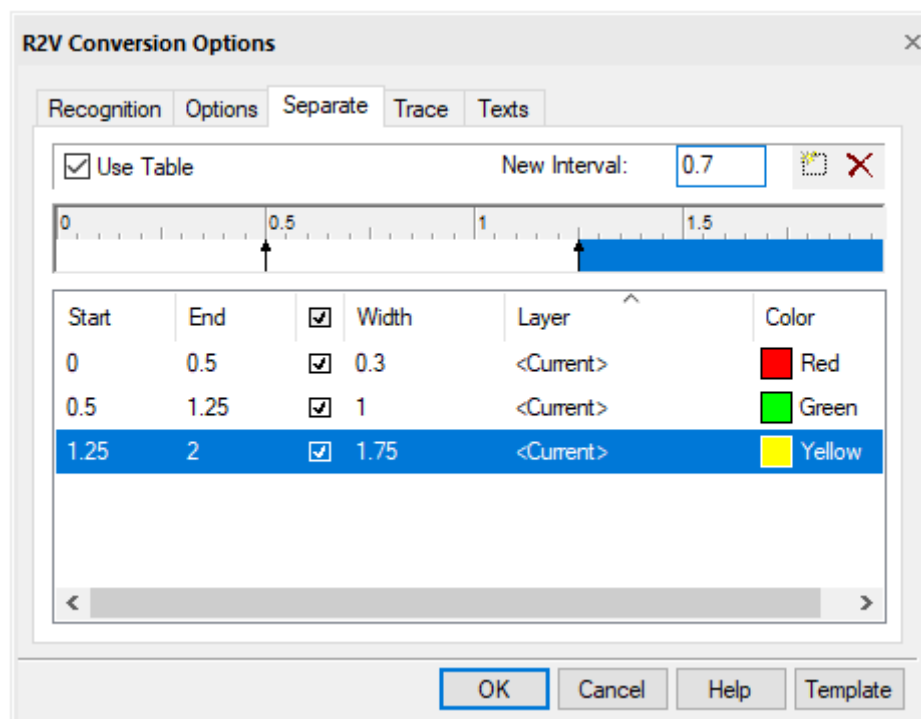

Using the **Separation** tab of the **R2V Conversion Options** dialog box, you can manipulate the properties of the vector objects being created: calibrate the thicknesses of the resulting vector objects, distribute vector layers objects corresponding to raster lines from the specified ranges of thicknesses to different layers and / or assign different colors to such objects.



Separate tab

### Separation options

Option	Description
Use Table	If this box is not checked, the program assigns the current property values (color and layer) to the objects; line weights of objects are set according to the thicknesses of the corresponding raster lines
<b>New Interval</b>	Allows you to create and delete thickness intervals in the table

field and buttons  	
Table of thicknesses	Allows you to edit intervals of objects thickness, assign color, layer and lineweight to the interval

### Thicknesses Table

The criterion for dividing vector objects by layers and / or by colors is the thickness of the original raster lines.

The table specifies the intervals of widths of the image raster lines, which, during vectorization, will be converted into vector objects with a specified line width and a specific color, and then placed on the specified layers.

The thickness table can contain an arbitrary number of elements – *thickness intervals*. Each interval is determined by two values - the lower and upper boundaries of the thicknesses of vector objects that fall into this interval. Each interval is assigned properties (thickness, color and layer), which are assigned to objects with thicknesses that fall within the interval.

All intervals are created within the thickness range from zero to the **Max. thickness** specified in the **Options** tab of the same dialog box. The initial contents of the table are as follows:

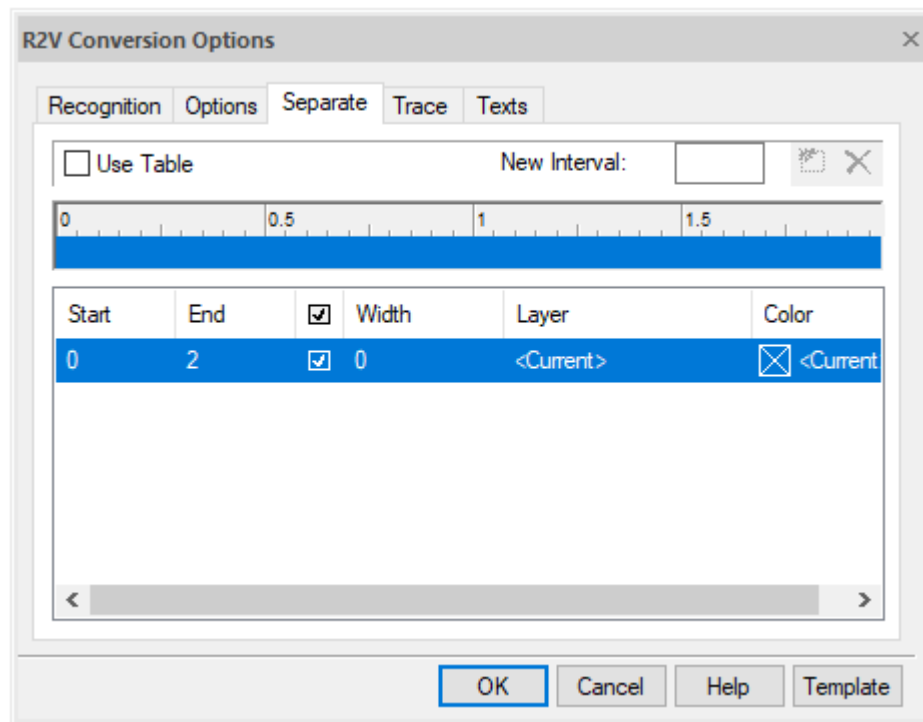

**Original content of the thicknesses table**

### Creating a new interval in the thicknesses table

Enter the value of the upper limit of the thickness interval in the **New Interval** field, click  **New Interval** button.

You can create an interval by left-clicking on the desired place in the thickness table ruler.

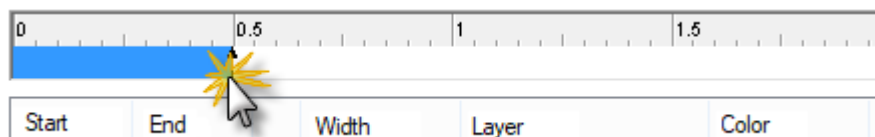

**Creating a new interval in the thicknesses table**

The existing interval, which contains the specified thickness value, will be split into two intervals. The properties of the new interval are inherited from the existing one. An arrow appears on the ruler to show the position of the upper boundary of the created interval.

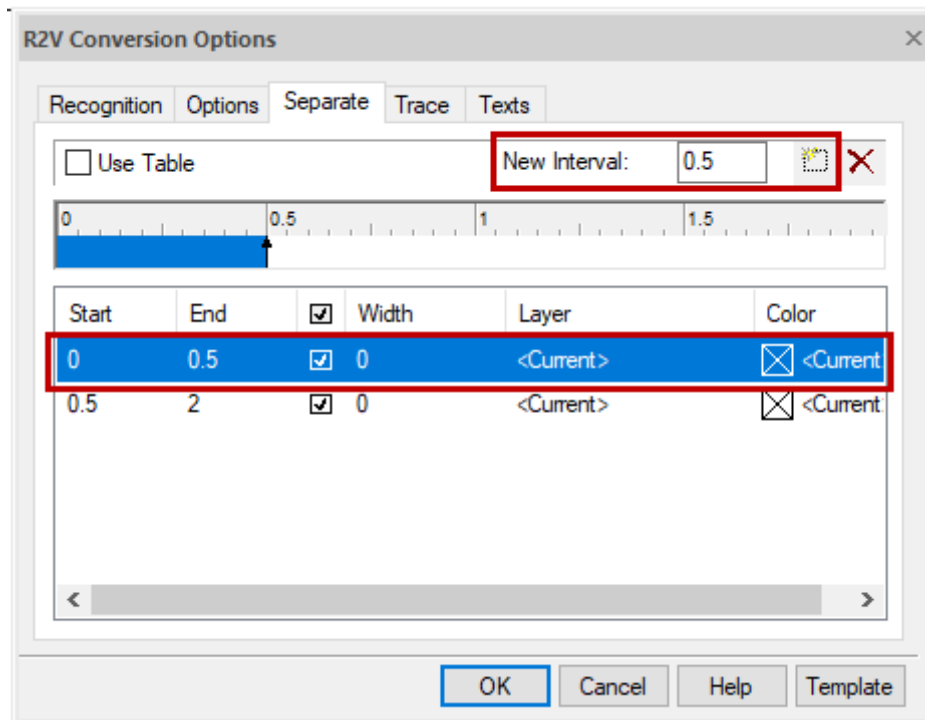

**Specifying the upper limit of the specified interval**

### *Changing the interval boundary*

You can change the boundaries of all intervals, except for the upper boundary of the last and the lower first, which always have the **Max. thickness** and **0** respectively. Changing the upper (lower) boundary of the interval entails a change in the lower (upper) boundary of the adjacent interval. If you set the value of the upper (lower) boundary greater (less) than the value of the upper (lower) boundary of the adjacent interval, then this interval will be deleted.

Left-click on the row of the thickness table corresponding to the required interval, and then on the field in the **Start** or **End** columns in the selected row and change the value of the upper or lower boundary of the interval, or move the corresponding arrow on the ruler of the table of thicknesses.

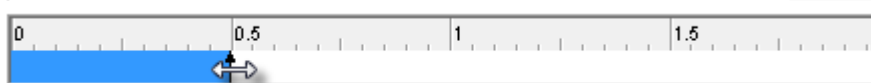

### *Deleting interval in the table of thicknesses*

In addition to the initial one, you can delete any interval.

Left-click on the row of the thickness table corresponding to the interval to be deleted, click  **Delete Interval** button or move one boundary arrow of the interval in the table ruler until it connects with another boundary arrow of the same interval. The interval will be deleted and one of the adjacent intervals will be given a new width value. If the movement occurs from left to right, then the width of the left adjacent interval increases; the width of the right adjacent interval increases as you move the cursor from right to left.

### *Changing interval properties*

Each interval has the following properties: measured thickness (**Start** and **End** columns), specified **Width**, **Color** and **Layer**.

During the vectorization process, these properties will be assigned to objects that have a thickness within the given interval.

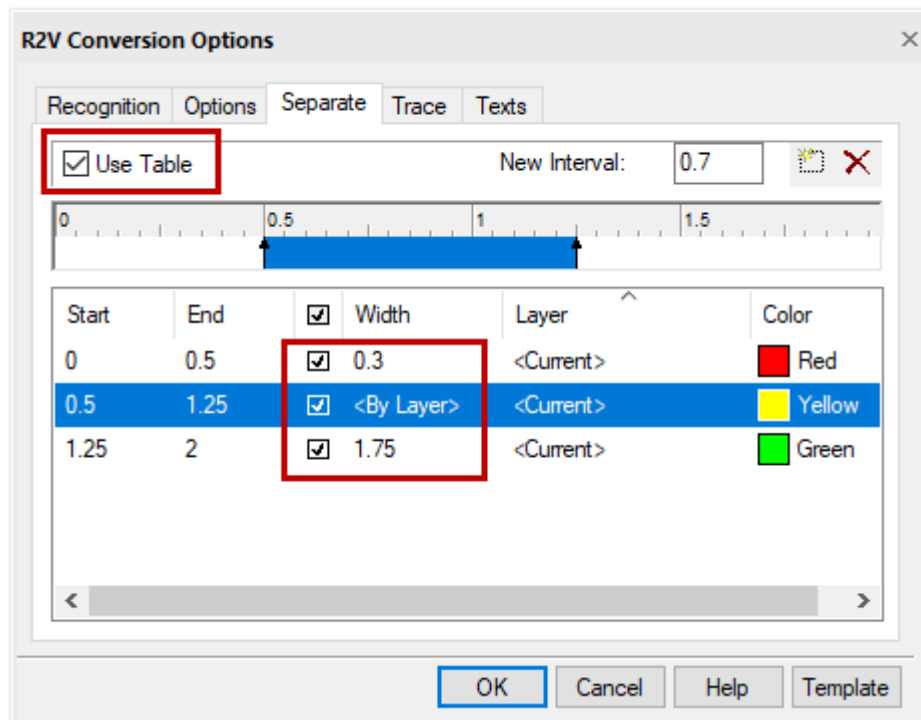

### Interval properties

When the **Use table** box is checked, the value specified in the **Width** field is assigned to all vector objects whose width is within the specified interval.

If you do not need to round off the line thickness within the interval to the values preset in the **Width** field, clear the checkbox in the corresponding line of the interval properties.

#### *Specify the interval width*

Select with the mouse the row of the thickness table corresponding to the desired interval, and then click in the **Width** column.

Enter the required value.

#### *Assign layer to interval*

You can assign name of any layer to the interval or select **Current**. All vector objects with thicknesses within the specified range will be created on the specified layer. If there is no such layer yet, it will be created automatically during vectorization. When you select the **Current** layer, objects will be created on it.

Select with the mouse the row of the thickness table corresponding to the desired interval, and then click in the **Layer** column.

Select the existing layer in the list or enter the name of a new layer that will be created during vectorization.

#### *Assign color to interval*

You can assign any color to the interval, including **Current**, **By Layer**, and **By Block**. All vector objects that have thicknesses within the specified interval inherit the specified color. If **Current** is selected, objects of the specified interval will be created with the current color.

Select with the mouse the row of the thickness table corresponding to the desired interval, and then click in the **Color** column.

Select the color from the list or specify it in the dialog box that opens when you click the **Other** option.

#### *Saving settings of the table of thicknesses*

Settings of the table of thicknesses can be saved in the settings file.

Click the **Template** button, select **Save**.

In the Save Template File dialog box:

1. set the file name with .TPL extension;
2. click **OK**.

By default, the file will be saved in the **Recognition options** folder located in the root folder.

### *Loading setting of the table of thicknesses*

Click the **Template** button, select **Load**.

In the **Open template File** dialog box:

1. specify the file name;
2. click **Open**.

## **Trace Tab**

To trace outlines, it is necessary to configure the parameters that affect the conversion procedure by this method.

In the **R2V Conversion Options** dialog box, open the **Trace** tab.

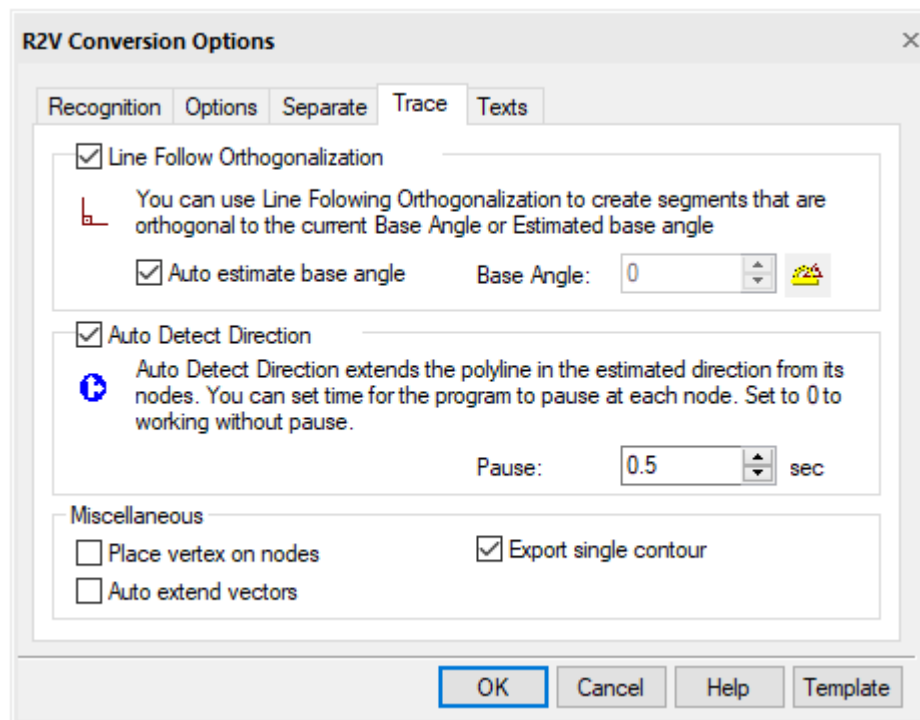

**Trace tab**

### **Trace tab options**

<b>Option</b>	<b>Description</b>
Line Follow Orthogonalization	When the box is checked, the polylines tracing automatically aligns the segments of the generated polylines perpendicular to each other. All segments are either perpendicular or parallel to the base direction. Base direction is set in the Base Angle field. When the Auto estimate base angle box is checked, the program automatically determines the base direction towards the longest polyline segment. The use of this option makes it easier to trace raster objects consisting of perpendicular segments (for example, tracing buildings on floor plans).
Auto estimate base	Automatically determines the base direction of orthogonalization

Option	Description
angle	of polyline segments. The base direction for each traced polyline is determined individually.
Base Angle	<p>Enter the angle defining the base direction of the orthogonalization or click the button next to the field name and specify two points in the image - the value of the angle between the line connecting these points and the direction of the X axis will be shown in the Base Angle field.</p> <p>When you check the Auto estimate base angle box, the Base Angle field is disabled.</p>
Auto Detect Direction	Enables a mechanism for determining the direction of continuation of tracing. Upon reaching the node point, the program tries to determine the next section of the raster line, which is a continuation of the traced object.
Pause	Specifies the time interval in seconds, during which the user should select a segment to continue tracing when working in the auto detect direction mode. If during the specified period the user does not manually specify another continuation, the program will continue tracing in the automatically selected direction. Setting this parameter to 0 specifies the trace procedure without delays.
Place vertex on nodes	When the box is checked, the program, while tracing polylines, inserts vertices at the intersections of the generated vector polyline with raster objects (at the node points)
Auto extend vectors	<p>This checkbox sets the forced selection and trace of arcs and lines.</p> <p>When recognizing lines, you should specify two arbitrary points on the line and the program will automatically extend the line to its endpoints.</p> <p>When recognizing arcs, specify three arbitrary points on the arc, the program will automatically extend the arc to its endpoints.</p>
Export single contour	When checked, tracing creates the outer contour of the object. If the checkbox is cleared, tracing creates both the outer contour of the object and the outlines for the inner closed regions ("holes"), if any.

## Texts Tab

### The order for automatic vectorization of texts:

1. configure vectorization parameters. In the **R2V Conversion Options** dialog box, in the **Recognition** tab, the **Text area** item should be checked, the required settings are made in the **Texts** tab;
2. select images to be converted;
3. run the automatic vectorization command  **Raster to vectors**. Vector objects will appear above the source raster;
4. to interrupt vectorization process, press **ESC**.

The text search and recognition module parameters are configured in the **Texts** tab of the **R2V Conversion Options** dialog box.

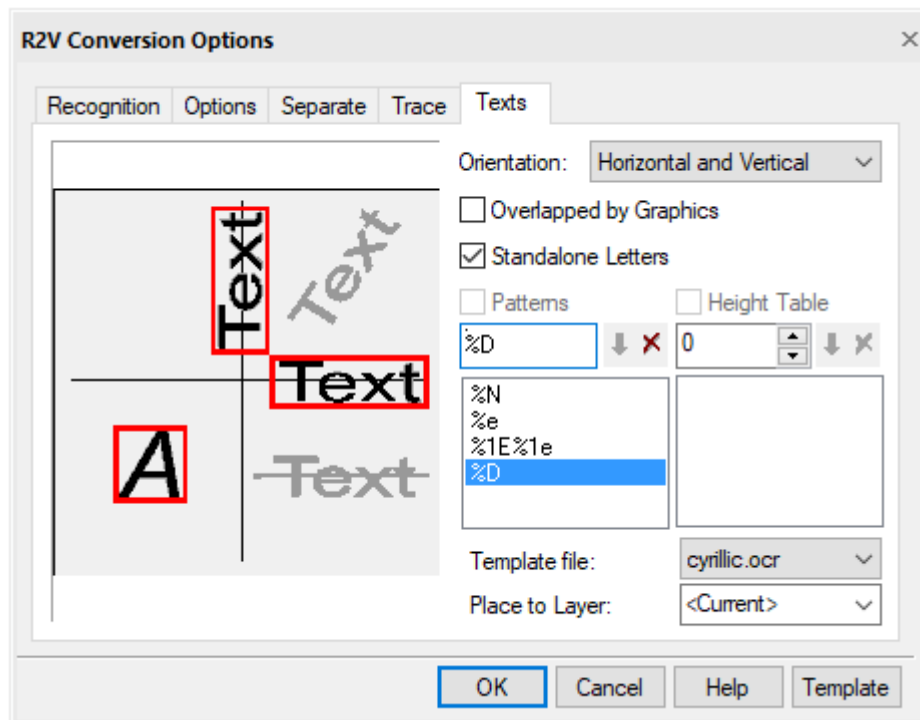

### Texts tab

Processing of raster texts is divided into two stages. First, the program searches for raster fragments containing raster texts. These fragments are called text areas.

Then the program applies to the found raster texts the operation specified as an additional parameter of the **Text area** algorithm in the **Recognition** tab.

One of such operations is raster text recognition using the built-in text recognition module (OCR).

The OCR module recognizes raster texts and creates text objects. It calculates the height and rotation angle of the created texts.

The program contains a file of OCR letter patterns (DEFAULT.OCR and CYRILLIC.OCR), with which the module recognizes English characters, digits, punctuation marks and special characters (the first half of the ASCII table). In addition, you can train the OCR module to recognize any other text characters.

If OCR cannot recognize a character, then that character is replaced in the text line with a "~" (tilde) character. If all the characters in the word are not recognized, OCR does not generate a corresponding text object.

#### Text Recognition Options

##### Orientation

Specifies the acceptable orientation of raster texts:

- **Horizontal** – searches for horizontal text lines. Text areas will be only horizontal;
- **Horizontal and vertical** - searches for horizontal and vertical text lines. Text areas will only be horizontal and vertical;
- **Arbitrary oriented** - searches for all text lines. Selecting this option can slow down the search for text areas.

##### Overlapped by graphics

When this option is enabled, the program searches for raster texts related to other raster objects. Selecting this option can slow down the search for text areas.





### Standalone letters

Searches for single text characters. If this option is disabled, the program will not find single text characters, but it will also not recognize graphic objects, markers, dashes, etc. as text.

### Patterns

To customize OCR, define a set of word patterns. A word pattern is a rule that defines the allowed sequence of characters within one recognized word. The OCR module will only recognize words that match one of the specified patterns (patterns are listed in the **Texts** tab of the **R2V Conversion Options** dialog box).

The  **Add Pattern** and  **Delete Pattern** buttons control the composition of the word pattern list.

Below there is the formal description of the word pattern definition:

```
[% [length] character type] || [letter]
```

#### Parameters for defining a word pattern

Parameter	Value
[%]	Start defining the character sequence
[length]	Any decimal number; absent for variable length
[type]	Character type (D, E, e, N, n, S)
[letter]	Standalone letter

#### Character type encoding

Character encoding	Decoding
D	Figures
E	Uppercase English letters (first alphabet)
e	Lowercase English letters (first alphabet)
N	Uppercase letters of the national alphabet (second alphabet)
n	Lowercase letters of the national alphabet (second alphabet)
S	Special characters (plus and minus signs, equal sign, etc.)
%%	Standalone character “%”
[letter]	Standalone character

#### For example:

- The **Rz%D** pattern corresponds to words that start with “Rz” followed by any sequence of digits, for example, “Rz40”, “Rz2.5”, “Rz5000”.
- The **%1N%n** pattern corresponds to words of the national alphabet with an uppercase first letter, for example “Hannover”, “Oslo”, “Moscow”.
- The **%D%%** pattern corresponds to words of the following type: “20%”, “1100%”, “12.50%”.
- The **%DV** pattern corresponds to words of the following type: “5V”, “220V”, “13.8V”.

### Height Table

In this field you can set the possible text heights. If you check the box, when generating recognized texts, the OCR module will create text objects with heights from this list, rounding the recognized height to the nearest one specified in the list.

### Template file

Specifies a sample letter library file used for recognition. Samples of letters are topological models of text symbols (letters, special characters, etc.), which are used to recognize raster text symbols.

It is possible to train the OCR module to recognize other text characters as well. During the learning process, OCR creates sample letters and writes them to the library. You can save sample letters both in an existing and in a newly created library file.

**NOTE.** If a custom library file with letter patterns is used, the OCR recognizes characters described only in that file.

### Place to layer

In this list, you can enter the name of the layer on which the texts obtained as a result of OCR work will be located.

## Train OCR



Ribbon: **Raster – Conversion** >  **Train OCR**



Menu: **Raster – Convert** >  **Train OCR...**



Command line: **OCRTRAIN**



This functionality is available only in the Raster module

The standard capacities of OCR module allow to recognize English letters, digits, punctuation marks and special characters (the first half of the ASCII table).



The OCR module can be trained to recognize any character. To do this, either replenish one of the existing libraries with new letter patterns, or create your own library.

The training process creates the examples (topological model) of text characters and place them in an open letter patterns library. Several patterns can correspond to one text character. Character patterns are stored in special letter pattern file libraries. These files are located in the OCR folder by default. You can replace any patterns in the existing library with your own.

### Letter pattern library

Run the **Train OCR** command.

In the **Train OCR** dialog box:

To create a new pattern library, click  **New** button or to add new patterns in the existing library, click  **Open** button, select the required library file in the dialog box and click **OK**.

Create new, replace or delete patterns of existing symbols.

Save the library in its own or a new file using the **Save** button.

Click **OK**.

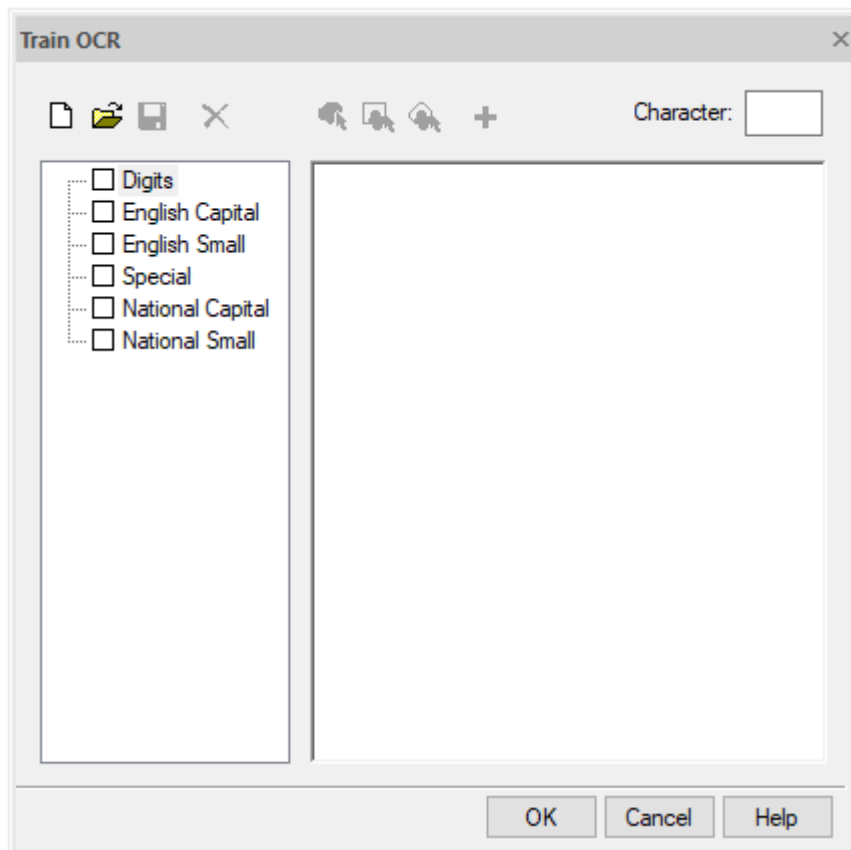

**Train OCR dialog box**

Creation, replacement and deletion of patterns in the library is performed using the buttons of the dialog box toolbar and the **Character** input field.



 - tools to pick a raster character.

 - **Add** and **Delete** buttons.

### *Creating a new letter pattern*

Enter the required letter in the **Character** field.

Using one of the selection tools, pick the raster character corresponding to the specified letter:

-  **Select character by floodfill.** To select, point with the cursor to an isolated raster character;
-  **Select character by window.** To select, set the opposite corners of the window that bounds the desired raster character;
-  **Select character by polygon.** To select, specify vertices of the polygon bounding the desired raster character; to complete the selection, press **ENTER**.

In case of mistake, repeat the selection procedure.

Click the **Add character to library** button.

The program will create a topological pattern of the letter and add it to the appropriate section of the patterns library.

The left part of the dialog box display the sections of the current pattern library: digits, English capital, English small, special, national capital, national small. Closed and non-empty sections are marked with "+" sign.

- Digits
- English Capital
- English Small
- Special
- National Capital
- National Small

### Sections of the current pattern letter library

The box to the left of the section name, when checked, connects all patterns in this section for recognition. Clearing the checkbox removes the connection of all patterns in this section. Any section can be opened by clicking on the field with the “+” sign, and enable or disable the necessary patterns located in this subsection. In order to connect/disconnect the pattern, check/clear the checkbox to the left of the pattern name.

Multiple patterns can be specified for each letter. For example, as shown in the following illustration for the letter “a”. The pattern set corresponding to this letter can be expanded by clicking “+”. The pattern can be selected by clicking on it with the mouse. When you select a pattern, its shape is displayed in the field on the right side of the window.

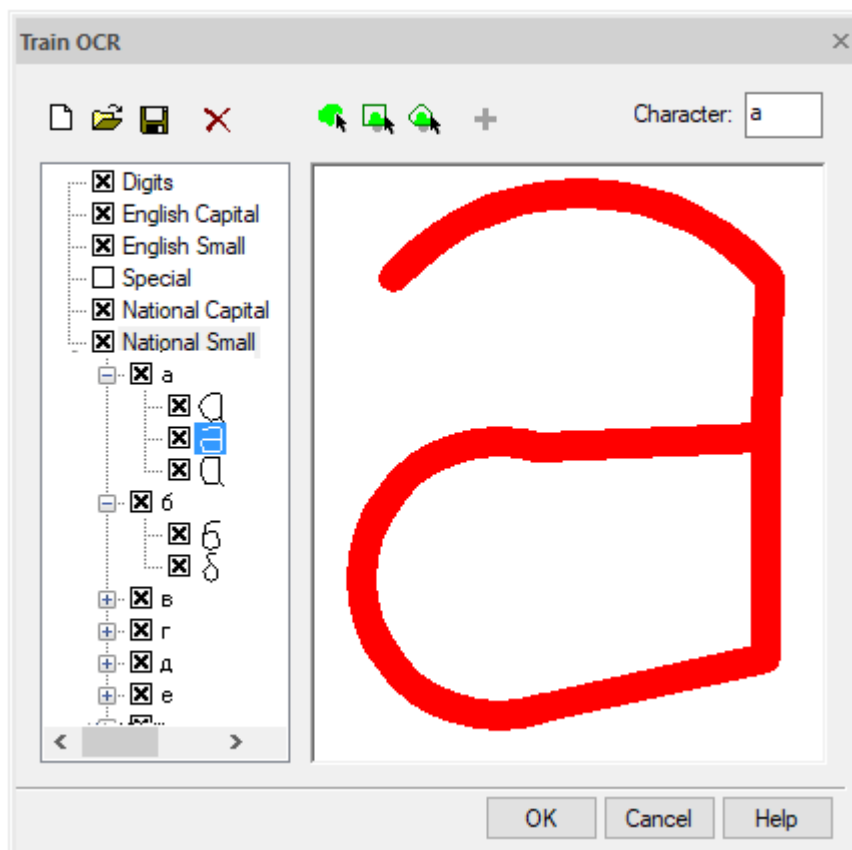

### Creating a letter pattern

Patterns can be both disabled (in this case they will not be used for recognition), and removed.

#### Removing a letter pattern

1. select the required pattern.
2. click  **Remove character** button.

# EXECUTION OF DRAWINGS COMMANDS

---

## *The Filling and Hatch Commands*

 Ribbon: **Annotate - Hatch** >  **Hatch**

 Ribbon: **Home - Draw** >  **Hatch**

 Menu: **Draw** -  **Hatch...**

 Toolbar: **Draw** - 

 Command line: **BHATCH, H, HATCH, HATCHCMD**

Hatching in nanoCAD means filling the selected area with the predefined *pattern*.

The *Hatch pattern* is a predefined pattern used to represent different materials such as steel, concrete, glass and so on. A solid fill can also be used as a hatch pattern.

The hatch can be *associative* or *annotative*.

An *associative* hatch is updated when you change the boundary.

An *annotative* hatch does not depend upon the boundary.

More details about hatch creating and editing are given in the following sections:

- Hatch dialog box
- Create Hatch;
- [Gradient](#);
- [Fast Hatch](#);
- [Fast Gradient](#);
- [Edit hatch](#).

## *Hatch Dialog Box*

The **Hatch** dialog box appears to select the hatch pattern and specify options:

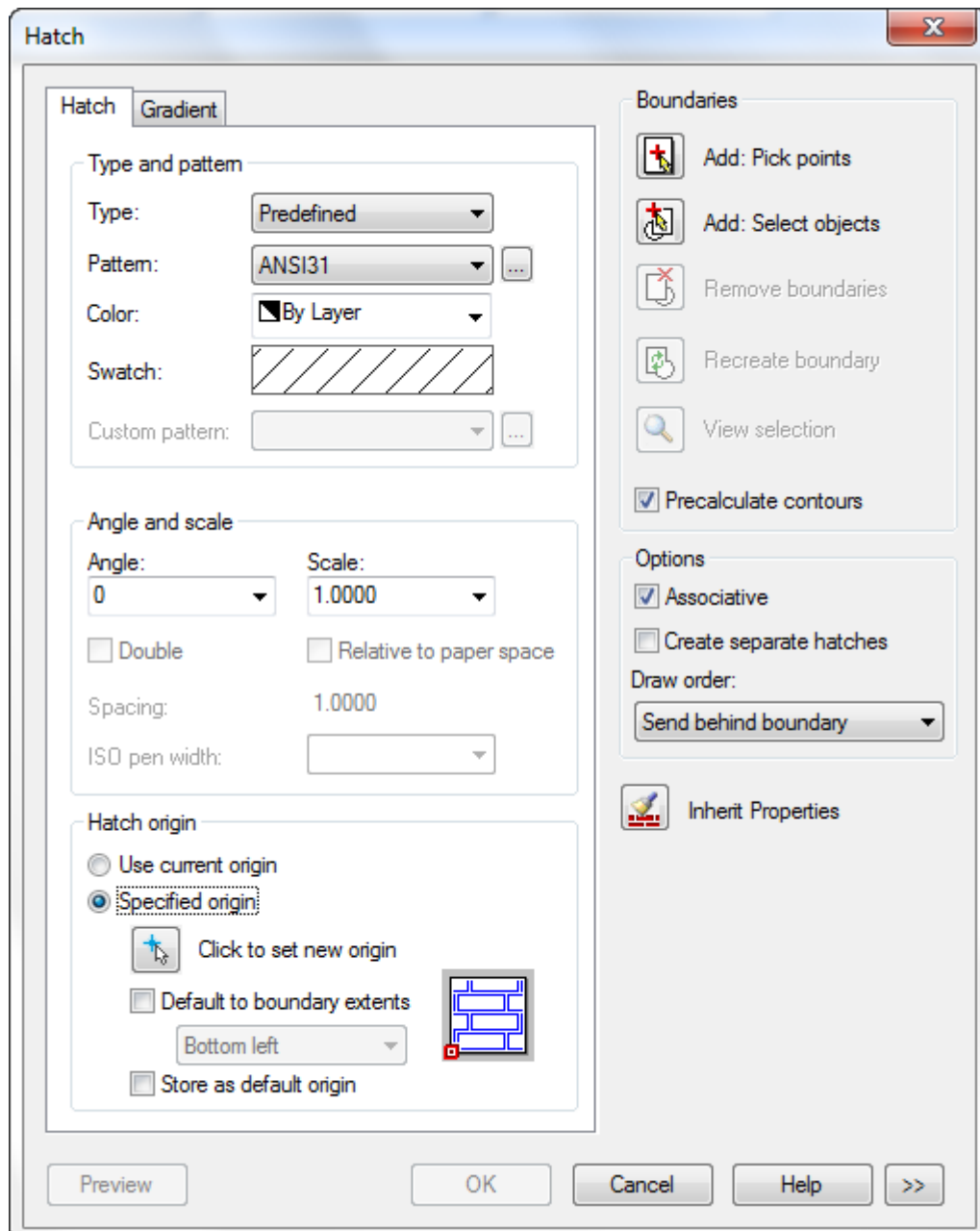

**Options:**

*Type and pattern*

**Type:** Drop-down list to select the type of hatch pattern:  
The following types are available:

- **Predefined**
- **User defined**
- **Custom**

**Pattern:** Drop-down list to select the available predefined patterns.  
The **Pattern** option is available only if you set the Type to **Predefined**.



This button opens the **Hatch pattern** dialog box.

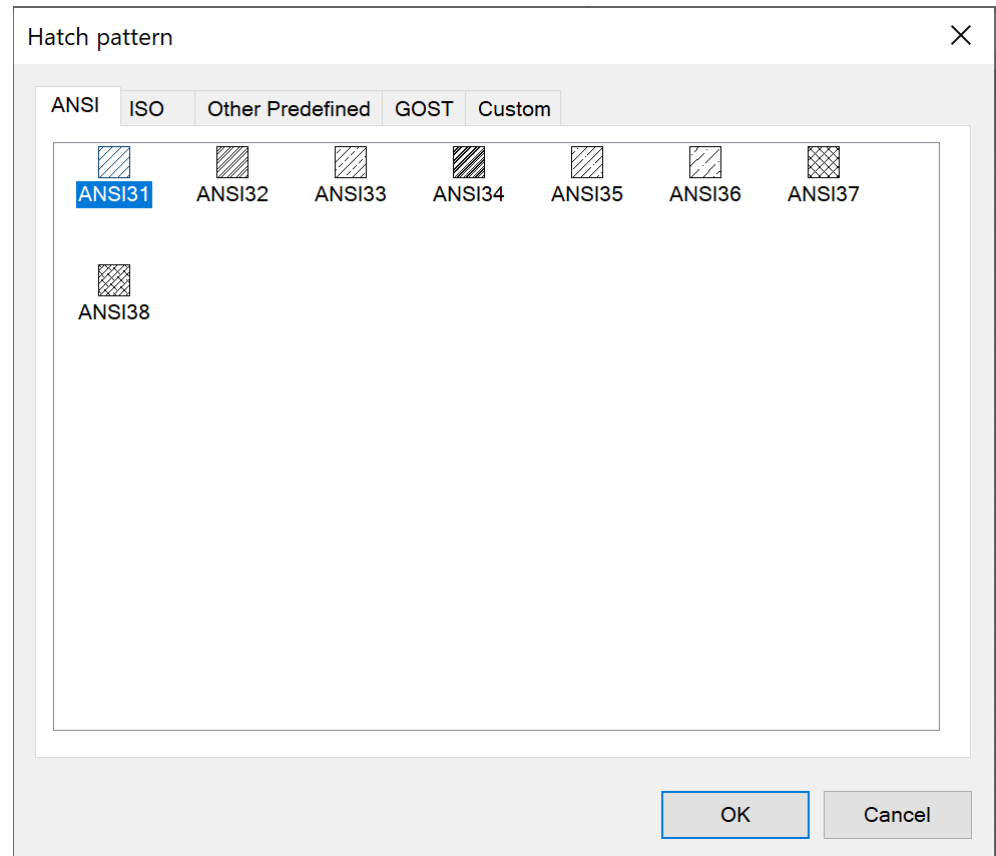

The dialog box contains the tabs:

- **ANSI** – the hatch patterns of the ANSI standard;
- **ISO** – the hatch patterns of the ISO standard;
- **Other Predefined** – the hatch patterns that are not related to the ANSI and ISO standards;
- **GOST** – samples of shading of materials graphic representations according to GOST;
- **Custom** – the list and patterns of the custom file format \*.pat.

By default, hatch samples are located in the C:\ProgramData\Nanosoft\nanoCAD X.X\SHX folder. You can change its location in the Options settings in the Standard Directories – Hatch Sample Files location. Custom hatch patterns are placed in the same folder.

**Color:** Drop-down list to select the hatch color.

**Swatch:** Displays a preview of the selected pattern.

Click the swatch to display the **Hatch pattern** dialog box.

**Custom pattern:**

Drop-down list to display the available custom patterns.

The **Custom pattern** option is only available for **Custom** type of hatch pattern.

If you select the **Custom** option in the drop-down **Type** list, the **Hatch Pattern** dialog box opens on the **Custom** tab:

The available custom hatch patterns display in the left part of tab. The selected pattern displays in the right part:

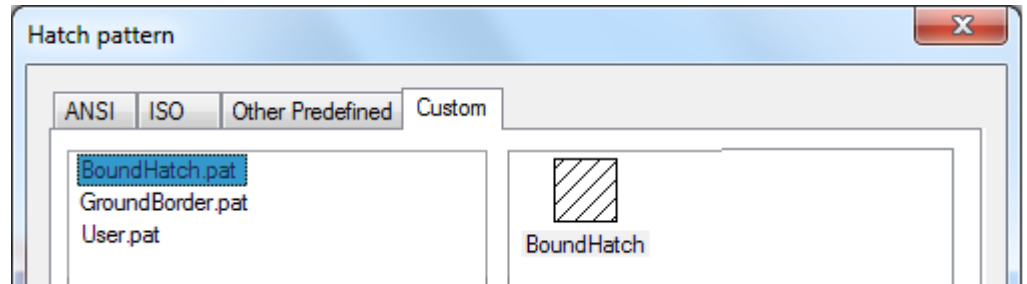

The custom hatch pattern (file with \*.pat extension) are placed in the folder:

*C:\ProgramData \Nanosoft AS\nanoCAD Int 24.0\SHX.*



This button opens the **Hatch pattern** dialog box.

*Angle and scale*

**Angle:**

Drop-down list to specify an angle for the hatch pattern relative to the X axis of the current UCS.

Values can be input from the keyboard.

**Scale:**

Drop-down list to expand or contract a predefined or custom pattern. Values can be input from the keyboard.

This option is only available if you set the Type to **Predefined** or **Custom**.

**Double**

Turns on/off the mode to draw a second hatch positioned at 90 degrees to the original hatch.

This option is only available if you set the Type to **User Defined**.

*Hatch origin*

Sets the start point to create the hatch.

Some hatches, such as brick patterns, need to be aligned with a point on the hatch boundary.

By default, all hatch origins correspond to the current UCS origin.

**Use current origin**

Turns on the mode of origin setting stored in the **HPORIGINMODE** system variable.

The origin is set to 0,0 by default.

**Specified origin**

Specifies a new hatch origin.



**Click to set new origin**

Specifies the new hatch origin point on the screen using the cursor.



### Default boundary extents

Turns on/off the mode for calculation of a new origin based on the rectangular extents of the boundary for the hatch.

From the drop-down list the following options are available:

- **Bottom left**
- **Bottom right**
- **Top right**
- **Top left**
- **Center**

The icon displays the current position of the origin point:



### Store as default origin

Turns on/off the mode for saving the value of the new hatch origin in the **HPORIGIN** system variable.

### Boundaries



#### **Add: Pick points**

Determines a boundary from the existing objects that form an enclosed area around the specified point. The dialog box closes temporarily and you are prompted to pick a point.



#### **Add: Select objects**

Determines a boundary from selected objects that form an enclosed area. The dialog box closes temporarily and you are prompted to select objects.



#### **Remove boundaries**

Removes from the boundary definition any of the objects that were added previously.

This option is unavailable if you have not specified points or not selected objects.



#### **Recreate boundary**

Creates a polyline or region around the selected hatch and optionally associates the hatch object with it.

This option is available when you edit the hatch.



#### **View selection**

Temporarily closes the Hatch dialog box and displays the currently defined boundaries with the current hatch settings.

This option is unavailable if you have not specified points or not selected objects.

## Precalculate contours

The checkbox activates the mechanism for contour preliminary search, which is used to dynamically highlight potential contours under the cursor during the procedure

for adding contours by specifying an internal point ( **Add: Pick points** button).

A preliminary search for contours is carried out immediately after clicking the **Add: Pick points** button. The search for contours will be performed only for the drawing geometry that will be displayed in the current view window at that time. If it takes time to search for contours, a window with a progress bar will appear.

The found contours are highlighted under the cursor in green, and if contours with an acceptable gap value are found (the value of the **Gap tolerance** field) – in red. In this case, the locations of the gaps in the contour are outlined with red circles.

The process of selecting hatch areas when the preliminary contour search mechanism is enabled is described in more detail below in the **Creating hatches** section.

### Options

#### Associative

Turns the associative hatch mode on/off.

#### Create separate hatches

Turns on/off the mode for changing a single hatch object that has several separate boundaries into individual hatch objects.

When this mode is turned on, the hatch will be created for each counter, which representing a separate object.

#### Draw order:

Drop-down list to assign the draw order to a hatch or fill. From the drop-down list the following options are available:

- Do not assign
- Send to back
- Bring to front
- Send behind boundary
- Bring in front of boundary



#### Inherit Properties

Temporarily closes the Hatch dialog box to specify boundaries using the hatch properties of a selected hatch object.

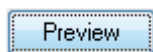

Temporarily closes the Hatch dialog box and displays the currently defined boundaries with the current hatch settings.

Press **ESC** to return to the dialog box.



Expands the **Hatch** dialog box to display more options.

The **More Options** section of the **Hatch** dialog box:

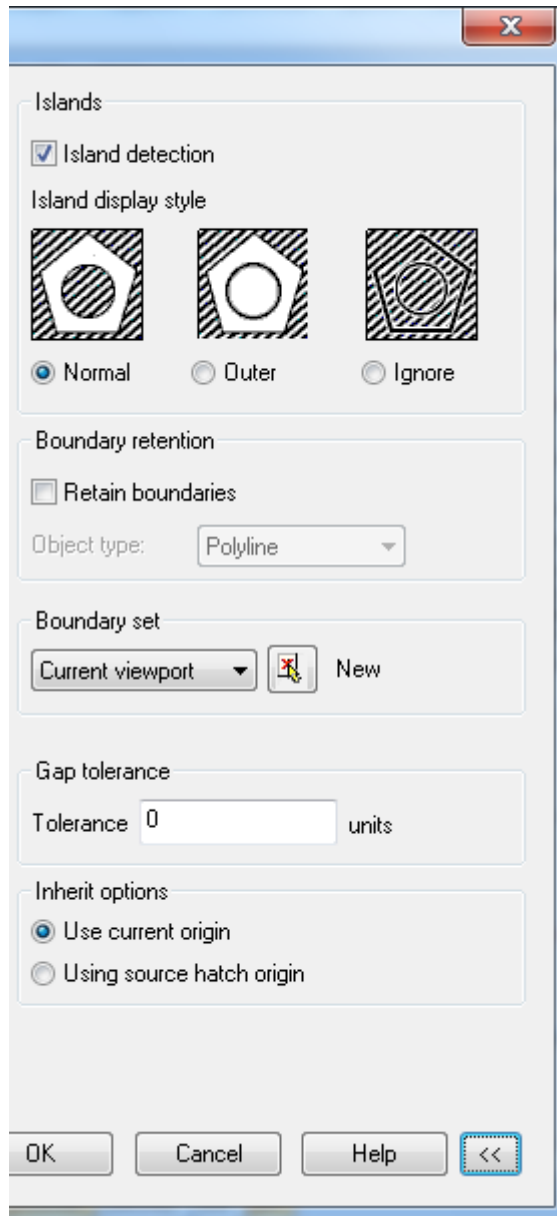

**The More Options section of the Hatch dialog box:**

*Islands*

**Island detection**

Turns on/off the mode to detect internal closed boundaries (islands).

**Island display style**

Selects the island display style.



**Normal**

Hatches inward from the outer boundary.

If the hatch encounters an internal island, it turns off hatching until it encounters another island within the island.



**Outer**

Hatches inward from the outer boundary. Hatch turns hatching off if it encounters an internal island. This option hatches only the outermost level of the structure and leaves the internal structure blank.



**Ignore**

Ignores all internal objects and hatches through them.

### Boundary retention

#### Retain boundaries

Creates boundary objects from the temporary hatch boundaries and adds them to the drawing.

#### Object type:

Controls the type of the new boundary object. The following types are available:

- **Region**
- **Polyline**

### Boundary set

Defines the set of objects analyzed when defining a boundary from a specified point. The selected boundary set has no effect when you use Select Objects to define a boundary.

From the drop-down list the following object sets are available:

- **Current viewport** - Defines the boundary set from everything within the current viewport.
- **Existing set** - Defines the boundary set from the objects that you selected with **New**.



#### New

Sets the maximum size of gaps that can be ignored when objects are used as a hatch boundary.

### Gap tolerance

#### Tolerance

Sets the maximum size of gaps that can be ignored when objects are used as a hatch boundary.

Enter a value, in drawing units, from 0 to 5000 to set the maximum size of gaps that can be ignored when the objects serve as a hatch boundary.

Any gaps equal to or smaller than the value you specify are ignored and the boundary is treated as closed.

### Inherit options

When you use **Inherit Properties** to create a hatch, these settings control the location of the hatch origin.

#### Use current origin

Uses the current hatch origin setting.

#### Using source hatch origin

Uses the hatch origin of the source hatch.

## Creating Hatch

The process of creating hatch can be divided into several conventional stages.

### 1. Set hatch parameters in the "Hatch" dialog

Including the selection of the desired hatch pattern in the **Pattern** drop-down list or in the **Hatch Pattern** dialog that opens after clicking the  button. The graphic structure of the selected pattern will be displayed in the **Swatch** field.

### 2. Specify the hatch area

To specify hatch areas, use one of the following methods:

- By specifying a point inside the area bounded by objects (using the  **Add: Pick point** button);

or

- By selecting objects that form a closed area (using the  **Add: Pick point** button).

**NOTE** When setting a hatch contour by specifying a point inside a closed area, the following nanoCAD objects are ignored (not taken into account): single-line and multi-line texts, dimensions, leaders and tables.

### 2.a Selecting hatch areas by specifying points inside contours

The process of specifying points inside hatch contours largely depends on the state of the **Precalculate contours** checkbox.

Checking the box activates the contour pre-search mechanism, which is used to dynamically highlight potential contours under the cursor during the procedure for adding contours by specifying an internal point. In addition, this mechanism significantly speeds up the process of specifying contours, since contour recognition occurs not during each mouse click, but in

advance, immediately after clicking the  **Add: Pick point** button.

A preliminary search for contours will be performed only for the drawing geometry that is currently displayed in the current viewport.

Information about the search process dynamics is displayed in the status bar.

Searching contours 26% Elapsed time: of

The preliminary search for contours is background and during its process you can specify the desired contours by clicking the mouse inside the contour. Selected contours are marked with green dots:

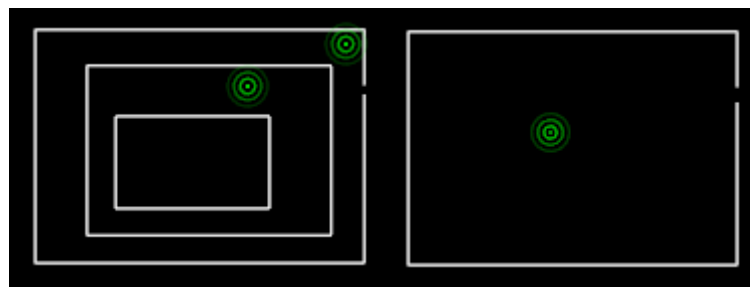

After contours precalculation is completed, the specified contours are selected for hatching and the points are erased. If there are breaks in the contours greater than the **Gap tolerance** parameter, the point indicator turns red:

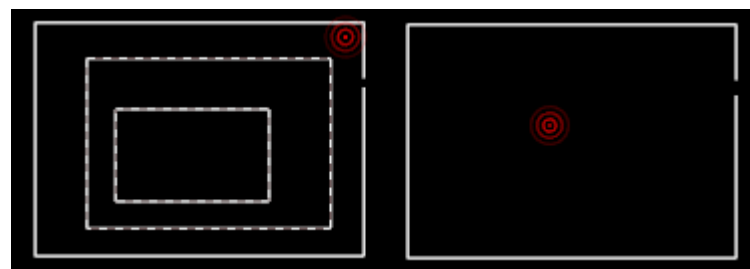

A message is displayed suggesting solutions to the detected problem:

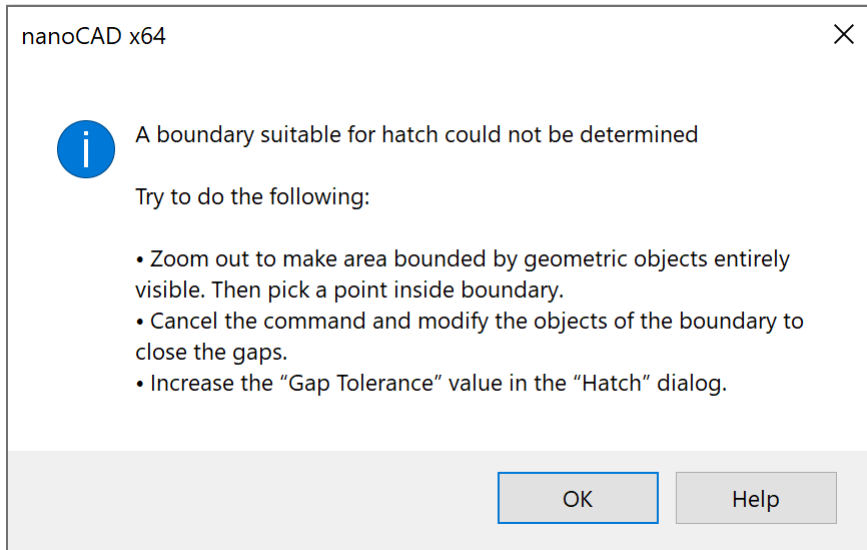

To deselect the problematic contours, click **OK** and click on the red dot again.

After a preliminary search, the found contours are highlighted in green under the cursor:

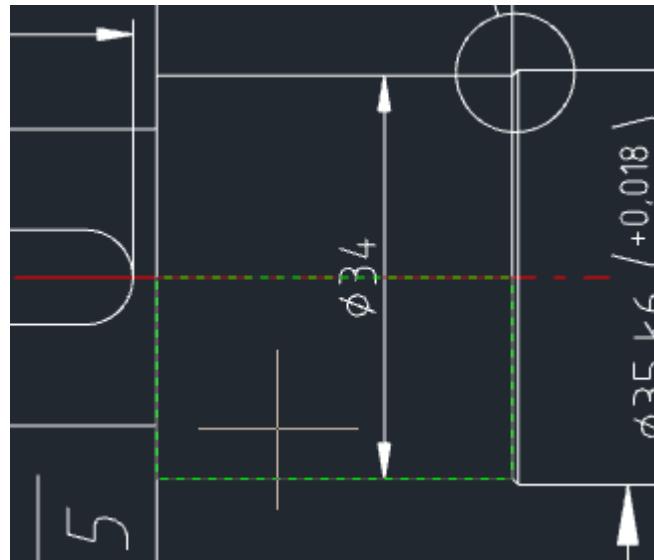

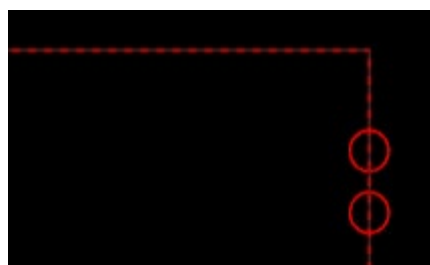

If you hover the cursor over contours with an allowable gap value (the value of the **Gap Tolerance** field) – red. In this case, the locations of the gaps in the contour are outlined in red circles:

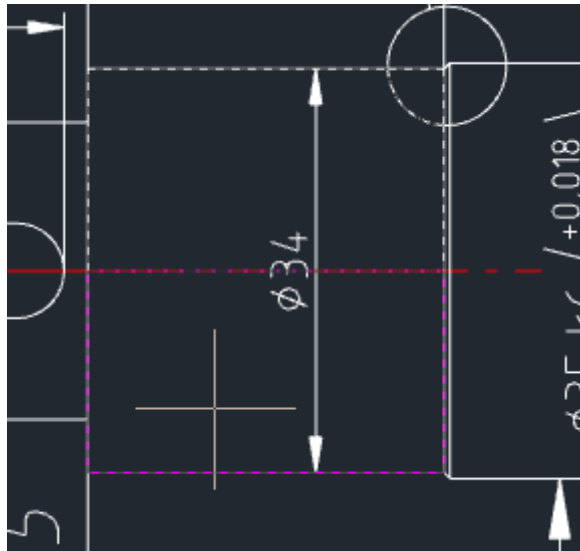

If you are satisfied with the highlighted contour, you need to mark it by clicking the left mouse button to add it to the set of contours for hatching.

The highlighting of contours added to the set under the mouse cursor turns pink.



It should be taken into account that the operation of preliminary search for contours was performed only for contours that were completely displayed in the viewport at the time of clicking the  **Add: Pick point** button. Therefore, if after clicking this button the drawing area was moved or the view was scaled (zoomed), the search process will begin again.

If, before starting the process of specifying points inside contours, the **Precalculate contours** checkbox was not selected, then the contours under the cursor will not be highlighted, since the process of recognizing all contours in the current view will not be carried out in advance. However, the process of specifying contours may take longer because each time you click the mouse, an attempt will be made to recognize a closed contour.

If it takes time to recognize the contour, a window with a progress bar will appear.

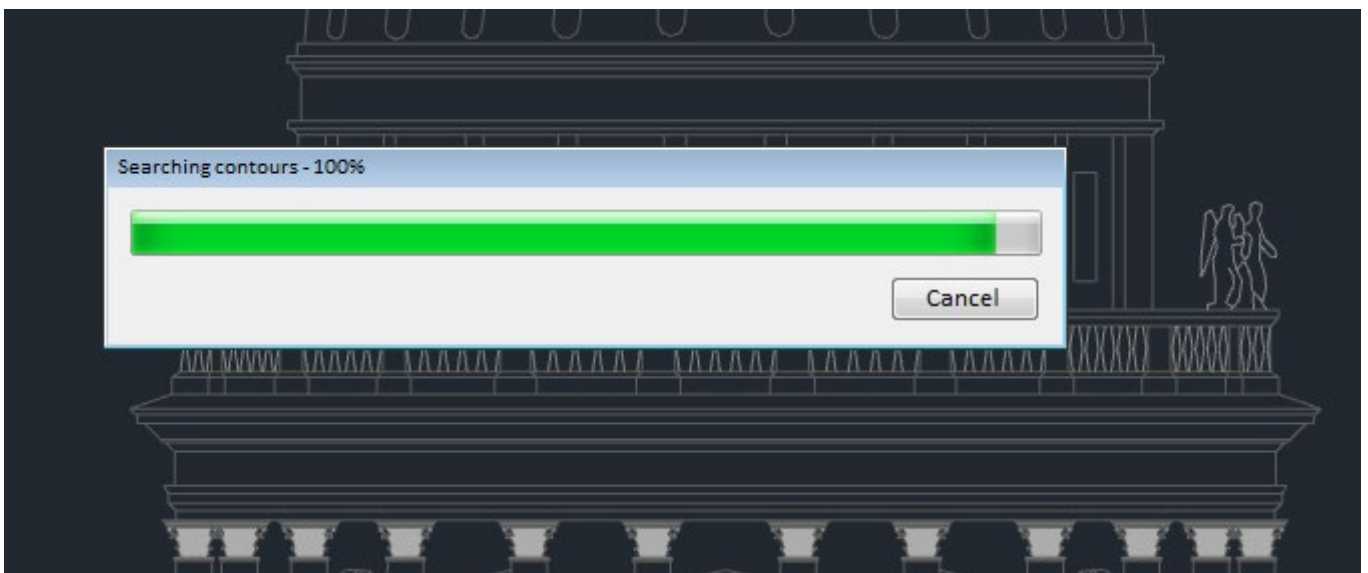

To exclude a contour that has already been selected, select it again by clicking the mouse.

If for some reason the selection results are not completely satisfactory, press **ESC** or select the **Cancel** command in the context menu to cancel the selected contours and return to the **Hatch** dialog to re-set the selection. The **Preview** and **OK** buttons in the dialog that opens will be disabled in this case.

To finish adding contours to the set, press **ENTER** or select the **Enter** command in the context menu to return to the **Hatch** dialog. Upon returning to the dialog, to preview the hatching result, click the **Preview** button. To complete the command without preview, click **OK**.

### *2.b Selecting hatch areas by specifying the objects that form the hatch areas*

Click the  **Add: Pick point** button and select the objects that bound the areas to be hatched.

To exclude an object from the selection, click on it again.



If the selection results are not completely satisfactory for any reason, press **ESC** or select the **Cancel** command in the context menu to cancel the selected objects and return to the **Hatch** dialog to re-set the selection. The **Preview** and **OK** buttons in the dialog that opens will be disabled in this case.

To finish adding objects to the set, press **ENTER** or select the **Enter** command in the context menu to return to the **Hatch** dialog. Upon returning to the dialog, to preview the hatching result, click the **Preview** button. To complete the command without preview, click **OK**.

### *When you preview the hatch result:*

1. If the preview of the hatch is satisfactory, click **Accept** in the command line or click **Enter** or **Accept** in the context menu to finish the command. Pressing **ENTER** also finishes the command.
2. If the preview is not satisfactory, select **Reject** in the command line or click **Cancel** or **Reject** in the context menu to return to the dialog box and change the hatch options. Pressing **ESC** also returns to the dialog box.

### *To create the hatch using the inherited properties of a selected hatch:*

1. Click the  **Inherit properties** icon. The **Hatch** dialog box closes temporarily, to select the prototype hatch.
2. Select the hatch object whose properties you want the hatch to inherit. The **Preview** and **OK** buttons in the opened dialog box will be blocked.
3. After selection, you can right-click in the drawing area and use the options on the context menu to switch between the  **Pick Internal Point** and  **Select Objects** options to create boundaries.
4. The order of the rest of the actions corresponds to the order of actions performed when you create a hatch.



## **Gradient Fill**

Gradient filling is sort of filling with effect of smooth transition from one color to another.

 Ribbon: **Annotate - Hatch** >  **Gradient**

 Ribbon: **Home - Draw** >  **Gradient**

 Menu: **Draw** -  **Gradient...**

 Toolbar: **Draw** - 

 Command line: **GRADIENTCMD, GRADIENT**

You can set options of gradient filling in **Gradient** tab of **Hatch** dialog.



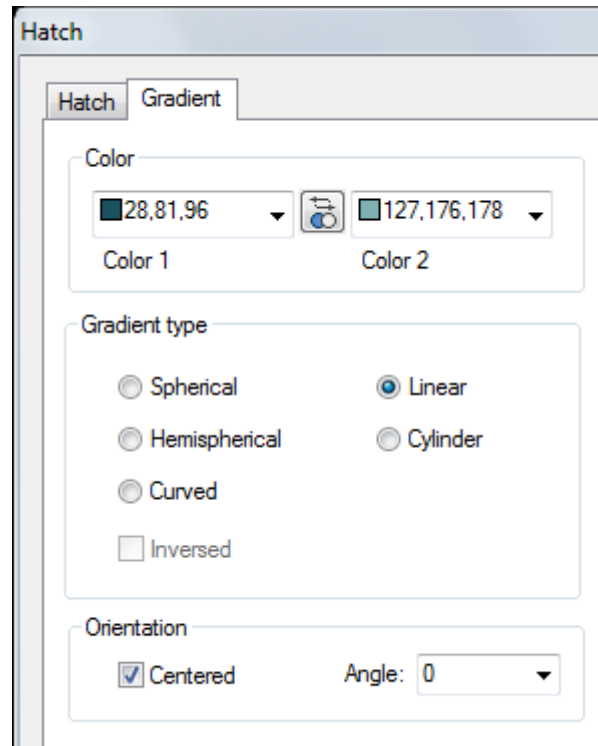

**Options:**

*Color*

**Color 1**

Specifies the first color of gradient filling.

**Color 2**

Specifies the first color of gradient filling.



Swap colors.

*Gradient types*



**Linear**

Enable the mode for creating linear gradient fill



**Cylinder**

Enable the mode for creating cylinder gradient fill



**Spherical**

Enable the mode for creating spherical gradient fill



**Hemispherical**

Enable the mode for creating hemispherical gradient fill



**Curved**

Enable the mode for creating curved gradient fill



**Inversed** (inversion of colors)

Enable/disable the mode for creating inversed gradient fill.



Spherical gradient fill

Inversed spherical gradient fill

### Orientation







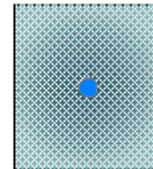

- Centered** Specifies a symmetrical configuration of gradient.  
If this parameter is not set, the gradient filling shifts up and left, making the illusion of light located to the left from object.
- Angle** Specifies the angle of gradient filling. Angle specified about current UCS and independently of angle of rotation of hatch.

Parameters of gradient fill can be edited on the **Properties** bar:

Pattern	
Gradient name	<input checked="" type="radio"/> Inverted spherical
Origin X	0
Origin Y	0
Associative	Yes
Islands detection style	Outer
Color 1	<input checked="" type="checkbox"/> 28,81,96
Color 2	<input checked="" type="checkbox"/> 127,176,178
Gradient angle	0
Centered	Yes
Geometry	



## Fast Hatch







-  Ribbon: **Annotate - Hatch** >  **Fast Hatch**
-  Ribbon: **Home - Draw** >  **Fast Hatch**
-  Menu: **Draw** -  **Fast Hatch**
-  Toolbar: **Draw** - 
-  Command line: **FASTHATCH, FH**



**Fast Hatch** command creates hatch in selected contours using last parameters of **Hatch** dialog box.

### To create a fast hatch:

1. Call **Fast Hatch** command.
2. Specify points inside of contours.
3. Click **ENTER** to create a hatch.

## Fast Gradient

-  Ribbon: **Annotate - Hatch** >  **Fast Gradient**
-  Ribbon: **Home - Draw** >  **Fast Gradient**
-  Menu: **Draw** -  **Fast Gradient**

 Toolbar: **Draw** - 

 Command line: **FASTHGRADIENT, FG**

**Fast Gradient** command creates gradient fill in selected contours using last parameters of **Gradient** dialog box.

*To create a fast gradient:*

1. Call **Fast Gradient** command.
2. Specify points inside of contours.
3. Click **ENTER** to create a gradient.

## Overriding Layer for New Hatches and Fills (HPLAYER)

Using the HPLAYER variable, you can override a layer for new hatches and fills. The variable allows you to specify a layer that does not exist in the document. In this case, a layer with this name will be created when creating a new hatch, and it will inherit its properties from layer 0. To use the current layer as a layer for new hatches, enter the dot ".".

## Modify Hatched Areas

 Ribbon: **Home - Modify** >  **Edit hatches**

 Menu: **Modify – Object** >  **Hatch ...**

 Toolbar: **Modify Object** - 

 Command line: **HATCHEDIT**

As with any other object, a hatch can be deleted, copied, moved, rotated, etc.

If a hatch is selected, you can change its scale and angle.

Hatch properties are edited in the same **Hatch** dialog that is used to create hatches.

You can edit the hatch properties in the **Hatch** dialog box that is used to create the hatch.

The **Edit Hatches** command allows you to recreate removed hatch boundaries. When you use the **Edit Hatch** command, the **Recreate boundary** option will be available in the **Hatch** dialog box.

*To recreate a boundary:*

1. Start the **Hatch** command from the **Modify – Object**
2. In response to the command line prompt *Select hatch object or [?]:* select the hatch for which you want to restore the contour.
3. In the **Hatch** dialog box, click the **Recreate boundary**  icon.
4. In the command line or context menu, select the Region or Polyline option to specify the object type to recreate the boundary.
5. Select Yes or No In the command line prompt *Reassociate hatch with new boundary? [Yes/No] <N>:*
6. In the **Hatch** dialog box click **OK**.

## Shape

 Ribbon: **Home - Draw** >  **Shape**

 Menu: **Draw** -  **Shape...**

 Command line: **SHAPE**

Shapes represent the objects described in a special format and are saved in text files with SHP extensions.

Shapes can be part of the description of complex line types (for more information, see the «Line Types» section).

SHX-fonts are also described and stored in the SHP-files. Each symbol of this font is a special type of figure.

*Shapes* are objects that you use like blocks. User-defined shapes are helpful when you need to insert a simple part many times and when speed is important. Blocks are more versatile and easier to use and apply than shapes. However, shapes are more efficient to store and draw.

The nanoCAD delivery includes two files (GOST 2.303-68.shx and ltypeshp.shx), containing forms descriptions. After installation, data files are located in a folder:

*C:\ProgramData\Nanosoft AS\nanoCAD Int 24.0\SHX.*

The GOST 2.303-68.shx file contains the shapes used to describe complex lines types in the GOST 2.303-68.lin file.

nanoCAD supports shapes created for AutoCAD.

To use the compiled file in nanoCAD, just place it to the folder:

*C:\ProgramData\Nanosoft AS\nanoCAD Int 24.0\SHX.*

The **Shapes** command allows you to insert shapes from (\*.SHX) files into the document. Selection of the file containing the shapes is carried out in the **Choose Form** dialog box.

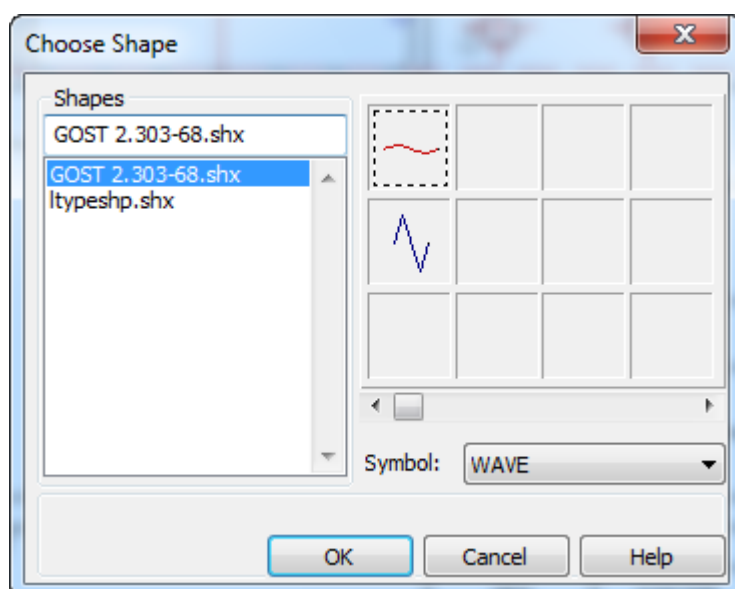

### To insert a shape:

1. In the **Shapes** section, choose the file. The slides with graphic images of the available shapes in the file are displayed in the box located in the top right part of the dialog.
2. Select the shape to insert and left click on the shape slide or select the shape name from the drop-down **Shape** list.

3. Click **OK**.
4. After closing the dialog box, perform the appropriate actions from prompts in the command line:



Specify insertion point:	Specify the point.
Specify shape rotation <0>:	Type the angle of rotation.
Specify shape scale <100.0000>:	Type the scale factor.

**NOTE:** You can set the parameter values of the shape using the cursor on the screen, in which case there are dynamic changes in the appearance of the inserted shape, depending on the cursor movement.

## Boundary

 Ribbon: **Annotate - Hatch >**  **Boundary**

 Menu: **Draw -**  **Boundary...**

 Toolbar: **Draw -** 

 Command line: **BO, BOUNDARY, BPOLY**

This command creates a region bounded by a closed polyline (boundary). A boundary can be created from lines, polylines, circles, arcs, ellipses, elliptic arcs, and splines. A boundary can be created from a single closed object or from several intersecting or adjoining end points of the objects bounded by the closed region.

You can calculate area or create a hatch for boundaries.

After starting the command, the **Boundary Creation** dialog box opens:

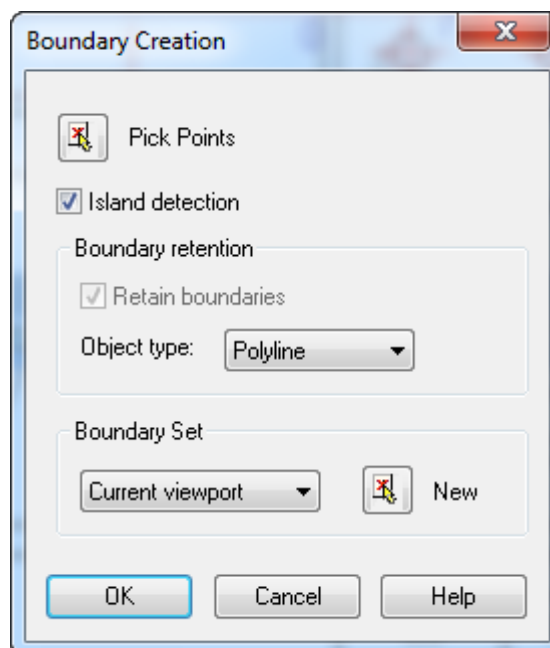

### To create a region or boundary:

1. From the **Object type** list select the **Polyline** or **Region**.
2. To search for internal closed boundaries (islands), select the **Islands detection** checkbox.

3. Click the  **Pick Points** icon.
4. Specify a point on the drawing for each internal closed boundary from which you want to create a region or a polyline.
5. Click **OK**.

*To limit the number of objects included in boundary determination, you can create a new set of boundaries:*

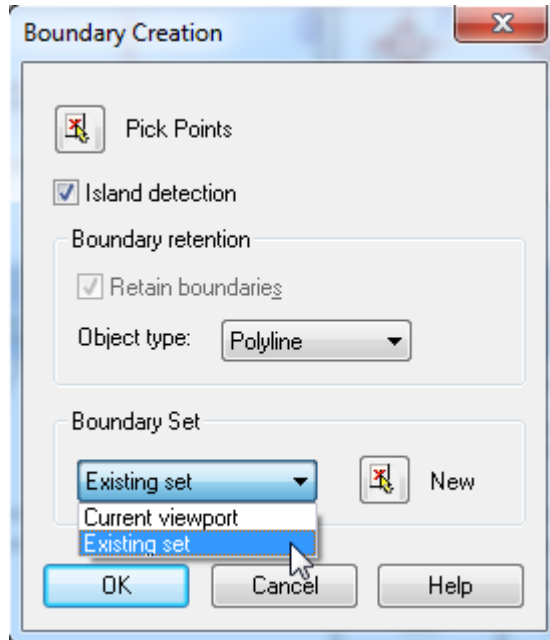

1. In the **Boundary Set** section, click the **New** icon.
2. Select the objects on the drawing that define the boundary.

When you select the **Current viewport** option from the list, the current boundaries set is cancelled, and a new boundaries set is created of all objects within the boundaries of the current viewport.

## Region

 Ribbon: **Home - Draw** >  **Region**

 Menu: **Draw** –  **Region...**

 Panel: **Draw** – 

 Command line: **REG, REGION**

The command to create a 2D region having a closed boundary and such properties as the centroid and the moment of inertia. Any enclosed area formed from segments, polylines, circles, arcs, ellipses, elliptic arcs and splines can be converted into a region.

The region boundary can be created of connected straight and curved objects having common boundary points. Any intersections or self-intersections of objects are not applicable.

Several regions can be created by one command.

### *To create a region*

1. Launch the command.
2. Select objects that define the region boundary.

After creating the region, the original objects are not saved.

For region there are two edit modes using grips, which are switched by the object's round grip ●:

Mode to move a region by the central square grip



Mode to edit geometry using grips on the contour.

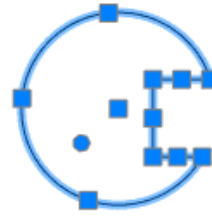

## Solid

 Ribbon: **Home - Draw** >  **Draw Solid**

 Menu: **Draw** –  **Solid**

 Command line: **SOLID**

This command creates filled polygons.

The first two points define one edge of the polygon.

Pressing Cancel or **ENTER** at the fourth point prompt creates a filled triangle. Specifying a fifth point creates a quadrilateral area.

The last two points form the first edge of the next filled area. The prompts *Specify third point: Specify fourth point or [Exit]:* are repeated. Specifying successive third and fourth points creates further connected triangles and four-sided polygons in a single solid object.

The order of specifying the vertices when you create a quadrilateral area affects the shape:

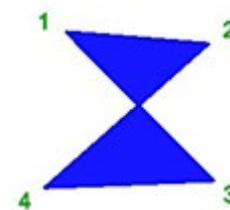
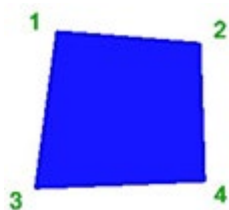

### Options:

Exit Ends the command.

### The following prompts are displayed:

Specify first point:

Specify point 1.

Specify second point:

Specify point 2.

Specify third point:

Specify point 3.

Specify fourth point or **ENTER**:

Specify point 4 or press **ENTER** to create a triangle or cancel the command.



Specify third point:

Press **ENTER** to end the command.

## Wipeout

 Ribbon: **Home - Draw** >  **Wipeout**

 Menu: **Draw** -  **Wipeout**

 Toolbar: **Draw** - 

 Command line: **WIPEOUT**

This command creates a polygonal area that masks underlying objects with the current background color.

The wipeout area is bounded by a frame that you can turn on for editing and turn off for plotting. You can convert a closed polyline consisting of line segments into a masking object.

Masking objects can be created in paper space to hide objects that are in model space.

**NOTE:** A masking object must lie above the masked ones.

### Options:

Undo                      Undoes the last specified point.  
This option allows you to undo all the specified points except the start point.

Close                      Closes the boundary and ends the command.

Polyline                    Creates a mask boundary from an existing closed polyline.

Frames                    Selects the visibility of the boundaries.  
The following prompt is displayed:  
Enter mode <ON> or [ON/OFF]:

#### Options:

ON    - Display the boundaries.

OFF   - Hide the boundaries.

### Options:

Specify start point or [ <u>Frames/Polyline</u> ]:	Specify the point.
Specify next point <Start tangent>:	Specify the next point.
Specify next point <Start tangent> or [ <u>Undo</u> ]:	Specify the next point.
Specify next point <Start tangent> or [ <u>Undo/Close</u> ]:	Specify all subsequent points defining the boundary inside which is necessary to hide the objects.
Specify next point <Start tangent> or [ <u>Undo/Close</u> ]:	Press <b>ENTER</b> or select the <u>Close</u> option to end the command.

When you create the boundary from closed polyline, the following prompts are displayed:

Specify start point or [ <u>Frames/Polyline</u> ]:	Select the <u>Polyline</u> option.
Select closed polyline:	Select the polyline.
Erase polyline? [ <u>Yes/No</u> ]:	Select the necessary option.



*When you create the boundary in the frames mode, the following prompts are displayed:*

Specify start point or [Frames/Polyline]:                      Select the Frames option.  
 Enter mode <ON> or [ON/OFF]:                                      Select the required option.

**NOTE:** Selecting the boundary visibility mode affects all mask objects on the drawing.

## Revision Cloud

 Ribbon: **Home - Draw** >  **Revision Cloud**

 Menu: **Draw** -  **Revision Cloud**

 Toolbar: **Draw** - 

 Command line: **REVCLLOUD**

Revision clouds are polylines that consist of sequential arcs. The maximum arc length cannot be set to more than three times the minimum arc length.

Revision Clouds are used to drawing explanatory labels and markings on the drawings.

When you start the command, the current parameters of the revision cloud are displayed in the command line:

Minimum arc length: 15000.000000 Maximum arc length: 15000.000000 Style: Normal

**NOTE!** The last specified arc length value is stored into the registry. To ensure consistency when you use different scale factors, this value is multiplied by the current value of the **DIMSCALE** system variable, which corresponds to the current value of the **Dimension Scale** or **Symbol Scale**.

### Options:

?                      Calls additional options to select the objects.

Arc length                      Specifies the minimum and maximum length of the arcs in a revision cloud.

Object                      Specifies a closed object to be converted to a revision cloud or to reverse the direction of the arcs in the revision cloud.

Style                      Specifies the style of the revision cloud.  
 The following prompt is displayed:  
 Select arc style or [Normal/Calligraphy]:

#### Options:

Normal                      - Normal style.  
Calligraphy                      - Calligraphy style.

Normal Style



Calligraphy Style



Revision Cloud



### Options:

Specify first point [Arc length /Object/Style]<Object>:

Specify the first point.

Guide crosshairs along cloud path...:

Move the cursor to the start point of required contour. When the cursor draws near to the start point, automatic closing of the cloud contour will happen and the command will be finished.

**When you convert a closed object to a revision cloud and change the direction of the arcs in the revision cloud to the opposite, the following prompts are displayed:**

Specify first point [Arc length /Object/Style]<Object>:

Select the Object option.

Select object or [?]:

Select object.

Reverse direction [Yes/No]<NO>:

Select the required option.

## Work with Text

The text you add to your drawings conveys a variety of information. It may be a complex specification, title block information, a label, or even part of the drawing.

In nanoCAD you can create and edit *single-line text* and *multi-line text*.

For short entries that do not require multiple fonts or lines, create *single-line text*. *Single-line text* is most convenient for titles and labels.

For long, complex entries, such as technical requirements or technical specifications, create *multi-line text*.

Single-line text, multi-line text, and attribute values can contain fields that are used in cases where the content of the text should depend on the value of a property of a document or other object.

To input text, the vector fonts with an .shx extension are used. These fonts are installed when you install nanoCAD. In addition, it is possible to use the TrueType fonts which are installed in the operating system and have a TTF extension.







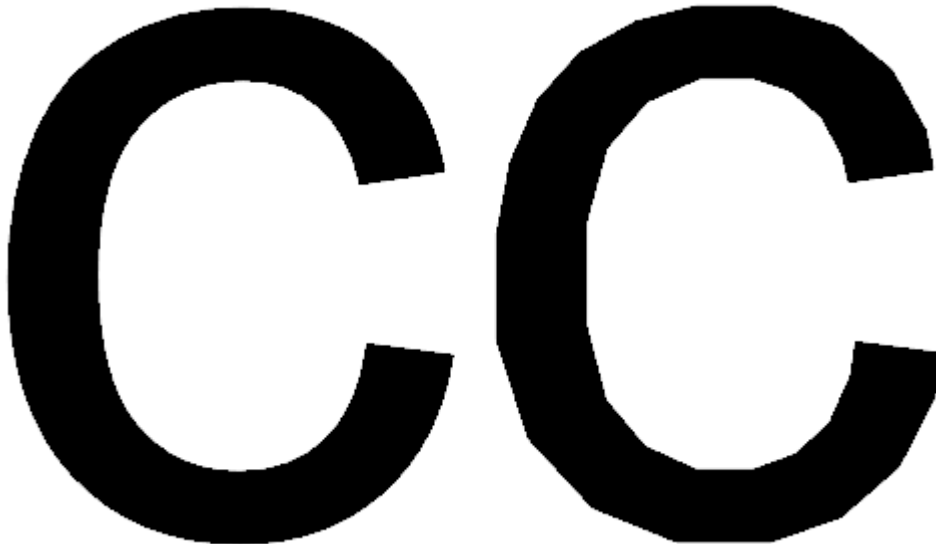

The nanoCAD tools for text creation allow you to select the typeface, set and edit the text height, weight and alignment modes.

### Text display quality

The text display quality is controlled by the TEXTQLTY variable. The lower the value of the variable, the less smoothing the text on the screen, but the faster the redraw speed. The variable can take integer values from 0 to 100. By default, TEXTQLTY = 50. Text characters are shown below with TEXTQLTY = 80 and TEXTQLTY = 50.



## Text

-  Ribbon: **Home, Annotate - Text** >  **Singleline Text**
-  Menu: **Draw – Text** >  **Single-line Text**
-  Toolbar: **Draw** – 
-  Toolbar: **Text** – 
-  Command line: **TEXT, DTEXT**

The command allows you to create one or more lines of text. Each text line is an independent object.

To create multiple lines of text, after each line is inputted press **ENTER** to move the cursor to the next line. You can also start a new line, by specifying it with the cursor on the screen.

To input «degree», «plus/minus», «diameter», you can use the special symbols: **%%d**, **%%p** and **%%c**.

Press **ESC** to cancel the command and remove the typed text.

To finish text input, press two times **ENTER** key or the key combination **CTRL+ENTER**.

By default, when you input text, the text style that is set as current in the **Text Style** dialog box is used.

If necessary, you can change the text style in the command line immediately after the start of the command.

### Options:

- Style            Type the name of the text style in the command line.
- Justify           Selects the mode of text justification.
- ?                    The display of all available text styles in the command line.

### The following prompts are displayed:

Input origin of text or [Justify/Style]:    Select the Align option.

Select justify mode [Left/Align/Fit/Center/Middle/Right/TL/TC/TR/ML/MC/MR/BL/BC/BR] <Left>:

Input origin of text or [Justify/Style]:

Type the text style or <Standard>:

Input origin of text or [Justify/Style]:

Specify text height <250.0000>:

Specify rotation of text <0>:

Type the text. Finish input with <Ctrl>+<Enter> or cancel it with <Esc>....:

Select text align mode.

Select Style option.

Type the name of the text style or ? symbol to show the names of all available text styles in the command line.

Input the origin of the text on the drawing.

Type in the command line or set by cursor on the screen the text height.

Type in the command line or set by cursor on the screen the rotation of the text.

Type the text. Press **CTRL+ENTER** to finish input and end the command.

When prompted to enter text, the context menu with text editing commands becomes available. This menu is described below in the **Editing singleline text** chapter.

## Singleline text

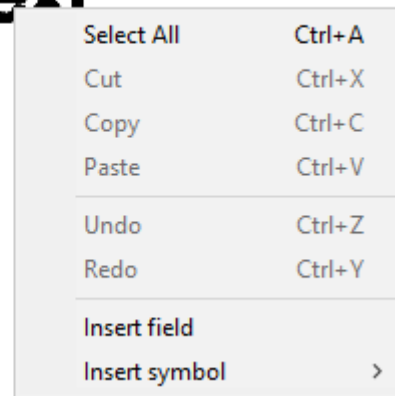

### Rotation mode for rotated text when creating and editing

Rotation variant is set by the option – **Rotate text in edit mode** in **Texts Settings** section of **Options** dialog box (menu **Tools – Options**).

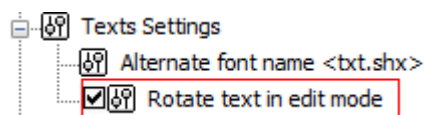

When the option is *enabled* in the mode of creating rotated text, only text object is rotated (text line becomes horizontal):

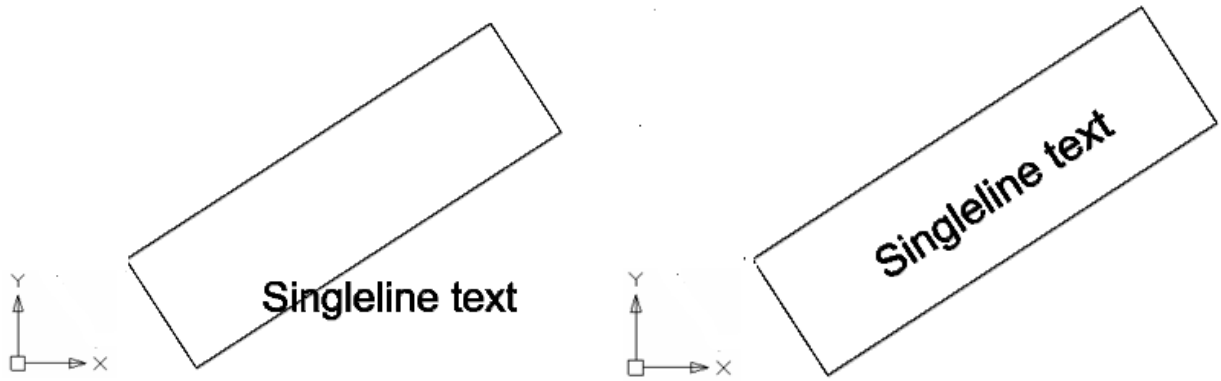

When the option is *disabled* – the whole drawing is rotated.

*Example of rotated text creation with disabled option:*

Option **Rotate text in edit mode** is *disabled*.

**To create rotated text:**

1. Input the origin of the text.
2. Specify the text height.
3. Specify the rotation of the text:

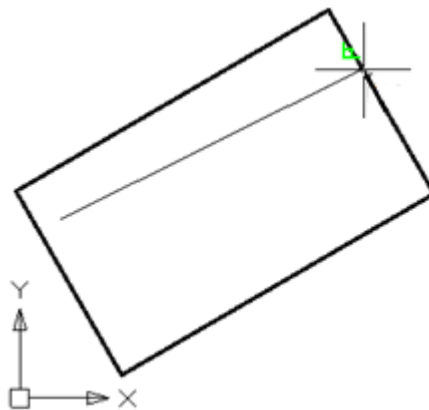

4. After specifying the rotation, the text line remains horizontal for convenience during input. The objects on the drawing will be rotated by the specified angle, but in the opposite direction:

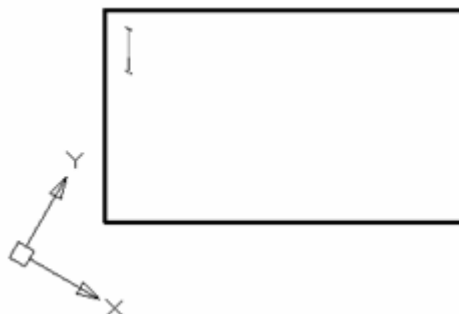







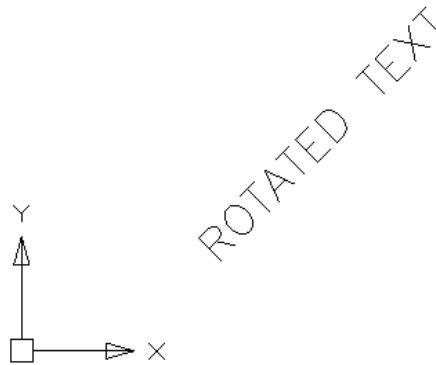

5. Type the text:



6. Finish input with **CTRL** + **ENTER**. The image on the screen returns to its normal view:



## Multiline Text

-  Ribbon: **Home, Annotate - Text** >  **Multiline Text**
-  Menu: **Draw - Text** >  **Multiline Text...**
-  Toolbar: **Draw** - 
-  Toolbar: **Text** - 
-  Command line: **MT, MTEXT, MTEXTCREATE, T**

Multiline text consists of any number of text lines or paragraphs that fit within a width you specify. It can extend vertically to an indefinite length. Can be split into columns. Multiline text is a single object.

There are more editing options for multiline text than there are for single-line text. For example, you can apply underlining, fonts, color, and text height changes to individual characters, words or phrases within a paragraph.

Draw a rectangular frame by double clicking a point to place multiline text there. Specify the top left corner first and then the bottom right corner.

In the **Text format** dialog box that opens, set the parameters of the multiline text:

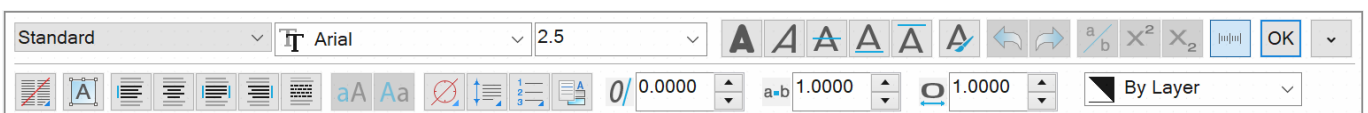

### Options:



Drop-down list to select the text style.



Drop-down list to select the font file that defines the style of the characters.

2.5 ▾

Input field for the characters height.

*Text formatting modes*



**Bold**

**CTRL** + **B**

Turns bold formatting on and off for new or selected text. This option is available only for characters using TrueType fonts.



**Italic**

**CTRL** + **I**

Turns italic formatting on and off for new or selected text. This option is available only for characters using TrueType fonts.



**Striked**

Turns strikethrough on or off for new or selected text.



**Underlined**

**CTRL** + **U**

Turns underlining on or off for new or selected text.



**Overlined**

**CTRL** + **O**

Turns overlining on or off for new or selected text.



**Copy text format**

Enables/disables the text format copy function. The function allows you to copy the following properties within one multiline text: font, height, style (bold, italic, strikethrough, underline, overline), slant, tracking (character spacing), aspect ratio, text color, text alignment (left alignment, center, justify, right, distributed), line spacing, bulleted and numbered list options, paragraph options (indents, tab stops). To use the function, select a part of the text or place the cursor on the text the properties of which you want to copy. Click the **Copy text format** button. Select the text to be formatted. To complete the formatting, press **ESC** or release the **Copy text format** button.



**Stack**

Converts the selected text with (/) symbol to stacked text with horizontal stack and vice versa. The text height of the numerator and denominator of fractions, as well as superscript and subscript text, is controlled by the TSTACKSCALE variable. The value of the variable is set as a percentage relative to the height of the main text and can vary from 25 to 125%.

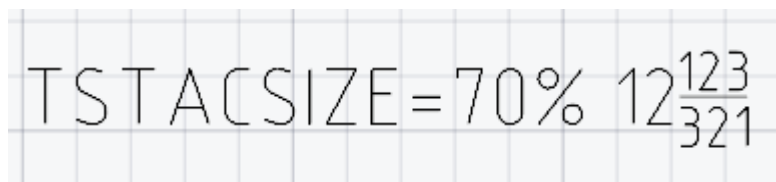

By default TSTACKSCALE = 70.

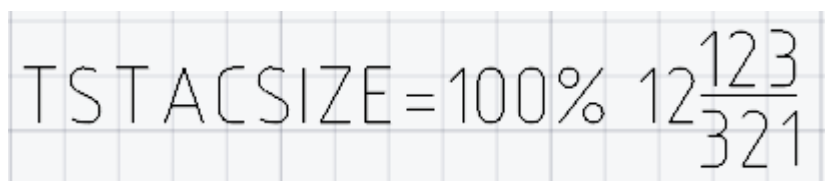

Makes text superscript and vice versa.



**Superscript**

Makes text subscript and vice versa.



**Subscript**

## Columns



### Columns

Creates and edits multiple columns. Opens the list of parameters:

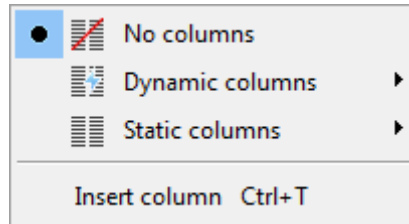

### No columns

Combines all columns.

### Dynamic columns

Dynamic columns modes:

- **Auto height**
- **Manual height**

### Static columns

Mode of static columns.

Set from 2 to 6 columns.

All static columns have the same height and alignment in the edges.

### Insert column

Inserts new column manually **CTRL+T**

### Column parameters

Opens the **Column Settings** dialog box.

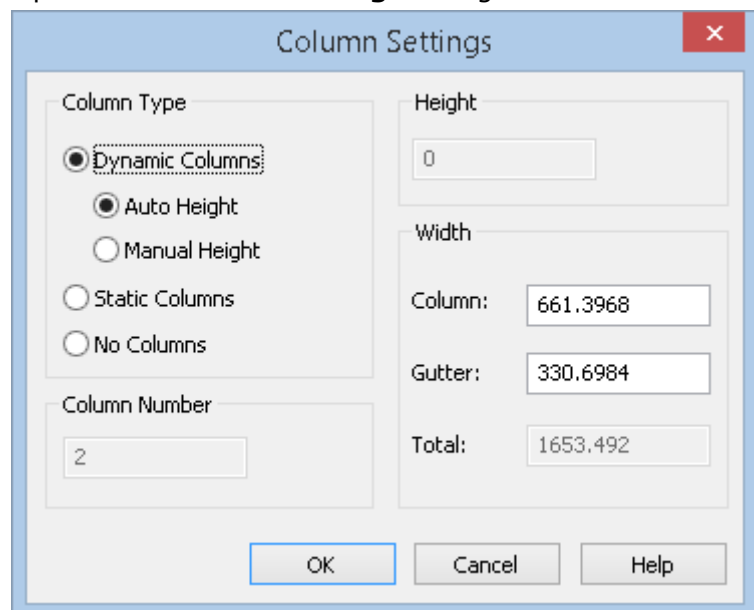

Displays and sets the following parameters:

- **Column type** - select the type of columns to be created.
- **Column Number** - set the number of columns. The parameter is available only for the **Static Columns** option.
- **Height** - displays and sets the height of the column. The parameter is available for editing **Static Columns** and **Manual Height** setting for dynamic columns.
- **Width** - Displays and sets column widths and column spacing. Parameter **Total** - displays the value of the total width of the text object.



### Text alignment



#### Change alignment

Selects the alignment mode for the insertion point and direction

### Text position modes



#### Align left

Sets the alignment of the text to the left.



#### Align center

Sets the alignment of the text to the center.



#### Align right

Sets the alignment of the text to the right.



#### Justified

Sets the text mode to justified.



#### Distributed

Sets the text mode to distributed.

### Change the case of selected text



#### Uppercase

Changes the selected text to uppercase (replace the lowercase characters with uppercase).



#### Lowercase

Changes the selected text to lowercase (replace the uppercase characters with lowercase).



#### Insert symbol

Inserts symbol from the list..

Degrees
Plus/Minus
Diameter
Almost Equal
Delta
Identity
Not Equal
Ohm
Omega
Squared
Cubed
Non-breaking Space
Symbols...
Other...

It is also possible to insert a non-breaking space by the combination of **CTRL**+**SHIFT**+**SPACEBAR** keys.

**Symbols...** and **Other...** open tables with other special symbols.



## Line Spacing

Sets line spacing between separate lines in the current or selected paragraph.

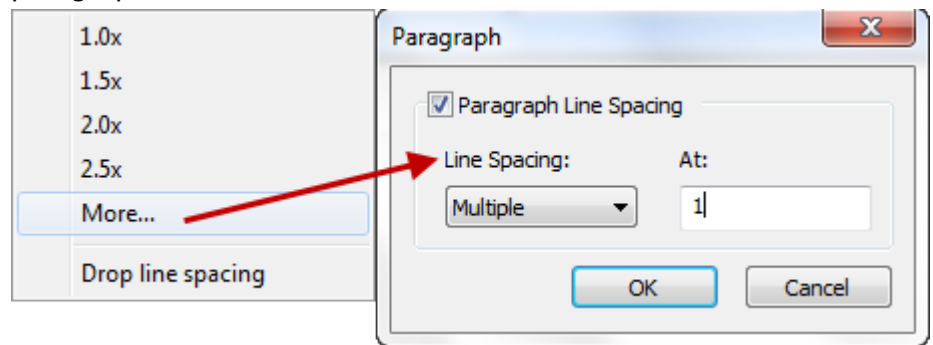

**1,0x, 1,5x, 2,0x, 2,5x** – Set the factor of line spacing on the text height.

**Drop line spacing**– drop line spacing to default of selected or current paragraph.

**More...** – calls **Paragraph** dialog box. Select other variants of line spacing

- **Exactly** – defines the space with an arbitrary unit value which user specified. Text height does not affect the line spacing.
- **Multiple** – sets the factor for text height. When text height is not consistent in one line, the line space will be determined by the largest text height value in that line.
- **At least** – considers specified value and text height. If text height is smaller than specified value then the line spacing takes user specified value. Otherwise line spacing takes text height.



## Numbering

Creates lists with numbers, letters or markers.

**Off** – numbering in turned off.

**Lettered** – alphabeting numeration with selected parameters:

- **Lowercase**
- **Uppercase**

**Numbered** – create numbered list.

**Bulleted** – create bulleted list with a specified marker: dot or hyphen.

To create a list, select the text and select the desired type of marking or numbering.

To start forming a numbered list, you can enter a number (or a number with a dot) at the beginning of the line and press the **TAB** key

By entering a letter (with or without a dot) followed by a tab, you can start forming a letter list.

A period or dash with a tab starts the formation of a bulleted list.

It is possible to create several numbered lists at once in one multiline text.

In this case, the numbering of the first list in a multiline text may start not from the first element. To start creating such a list, enter the desired initial value (with or without a dot) and press the **TAB** key. The list will begin to form from the specified value.

To form multi-level lists, select the required lines of the list and press the **TAB** key, moving the numbering one level deeper.

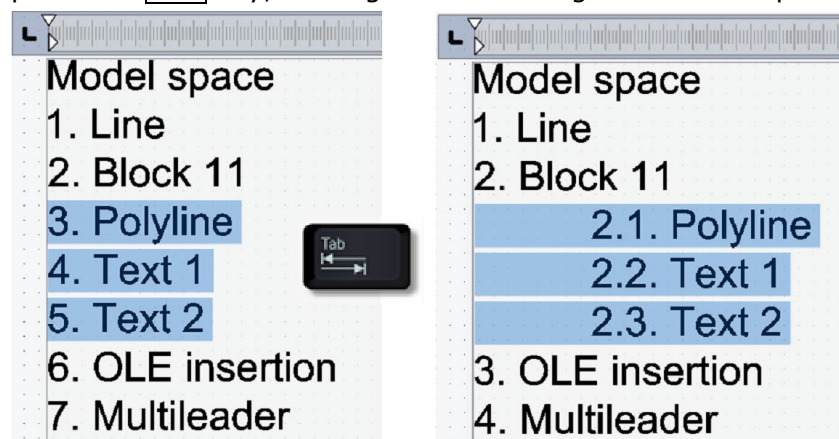

With the **TAB** key, you can shift not only the levels of numbered lists, but also the levels of alphabetic and bulleted ones, with automatic formatting of the correct labeling.

To form complex nested lists (alphabetic inside numbered, and vice versa), you need to select a regular nested list and change its type.

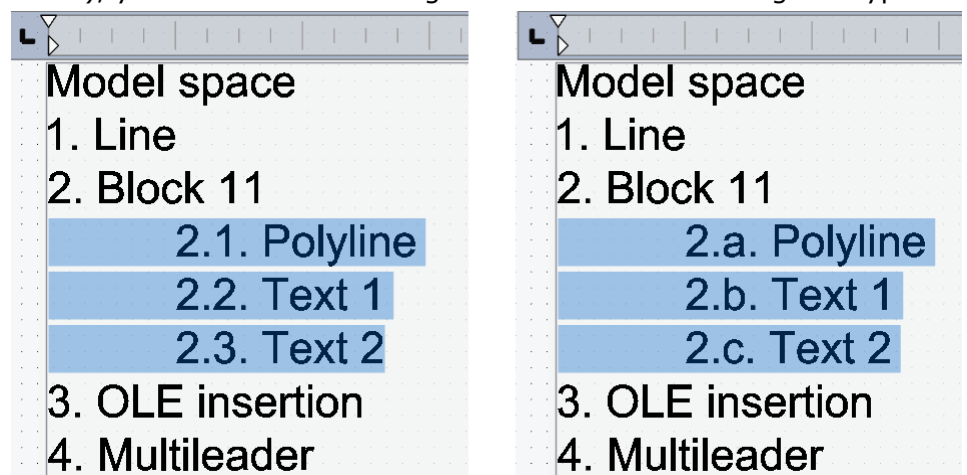



## Insert field

Opens **Field** dialog box to insert field to the text.

### Additional options

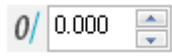

Determines the forward or backward slant of the text.  
A positive angle slants text to the right. A negative angle slants text to the left.

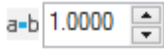

Specifies character spacing. Values from 1 to 0 shorten the interval. Values >1 increase it.

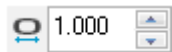

Widens or narrows the selected characters.

The *1.0* setting represents the normal width of the letter in this font.

Set to more than *1.0* to increase the width, and set to less than *1.0* to decrease the width.

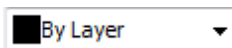

Drop-down list to select the color for the text.



**Undo**

Undoes actions in the text editor.



**Redo**

Redoes actions in the text editor.



Enables / Disables the display of the ruler at the top of the text editor.



Completes editing multiline text and closes the text editor. To do this, you can also use the key combination **CTRL** + **ENTER**.



Context menu calling.

### To create multiline text:

1. Set the text area by specifying the top left corner first and then the bottom right corner.
2. Set the required options in the **Text format** dialog box.
3. Click the cursor inside the text area on the drawing.
4. Type the text from the keyboard.

To move to a new line, press **ENTER**.

To insert «degree», «plus/minus», «diameter» symbols, use the **Insert symbol** command from the context menu:

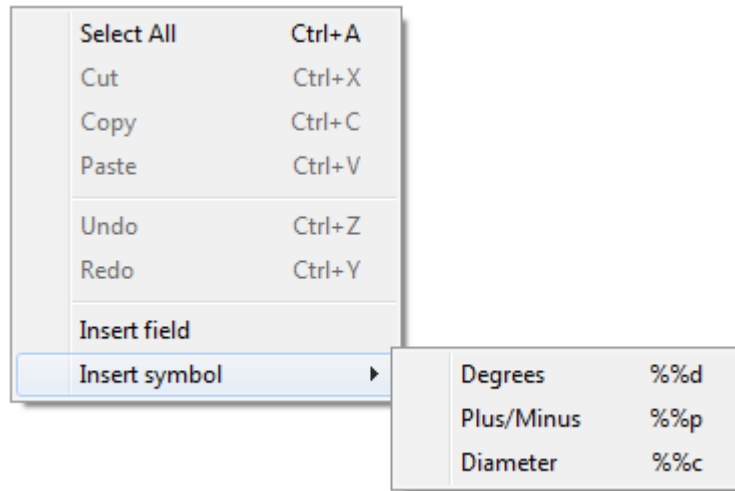

**NOTE!** Text can be overlooked if the font size in the **Text format** dialog box is set too small compared to the scale of the drawing.

5. Set the position of the selected text using the text input window elements:

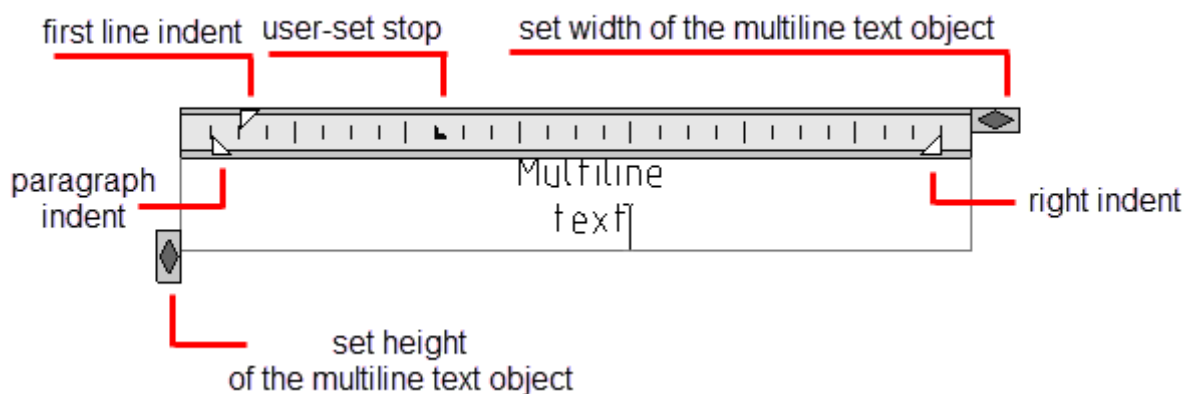

Double-clicking the left mouse button on the  width button adjusts the frame width to the text size.

6. To complete typing the multiline text, press the key combination **CTRL** + **ENTER** or click **OK** in the **Text format** dialog box. You can also click outside the text input area on the drawing to complete the typing of the multiline text. The **ESC** key also completes the command, but the following prompt to save the changes appears:

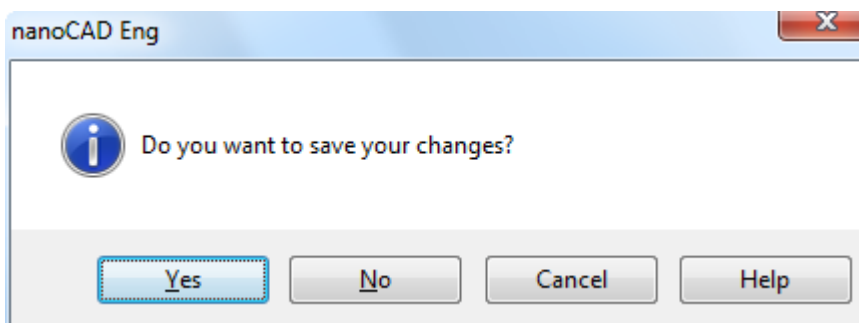

**NOTE:** Press **ESC** to cancel the text input and finish the command.

## Background Mask



Ribbon: **Annotate - Text** >  **Hiding the Background**



Toolbar: **Modify 2** - 



Command line: **BACKGROUNDMASK**

You can specify a background mask for multiline text, for multiline multileader text and for multiline block attribute text. A background mask allows text to appear on an opaque background of a specified size and color.

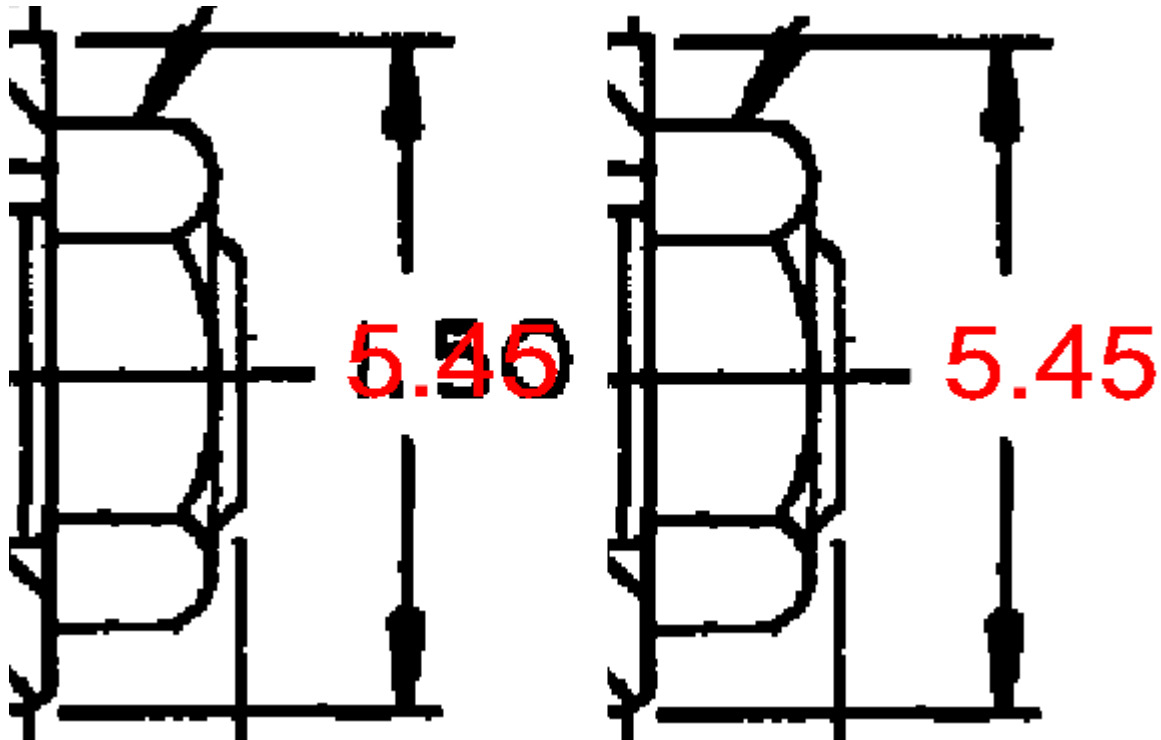

A mask is created for the entire text area. When you resize the text area using grips, the mask (background) is also resized.

Objects can be selected before or after command execution. This allows you to apply the command to several selected heterogeneous objects at once (multiline texts, multileaders, block attributes).

### To create a background mask:

1. Select the multiline text, multiline multileader text or multiline block attribute text.
2. on the **Properties** panel, click the  button to the right of the **Background Mask** parameter (the **Text** section):

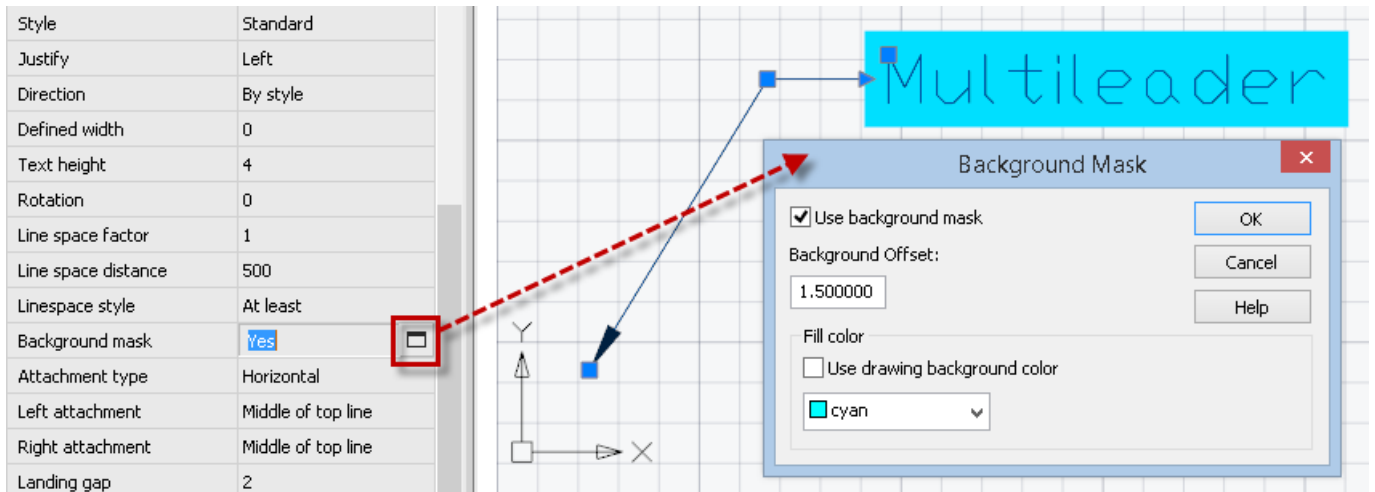

Or select the **Background Mask** item in the context menu, while editing multiline text (or multileader multiline text, or attribute multiline text):

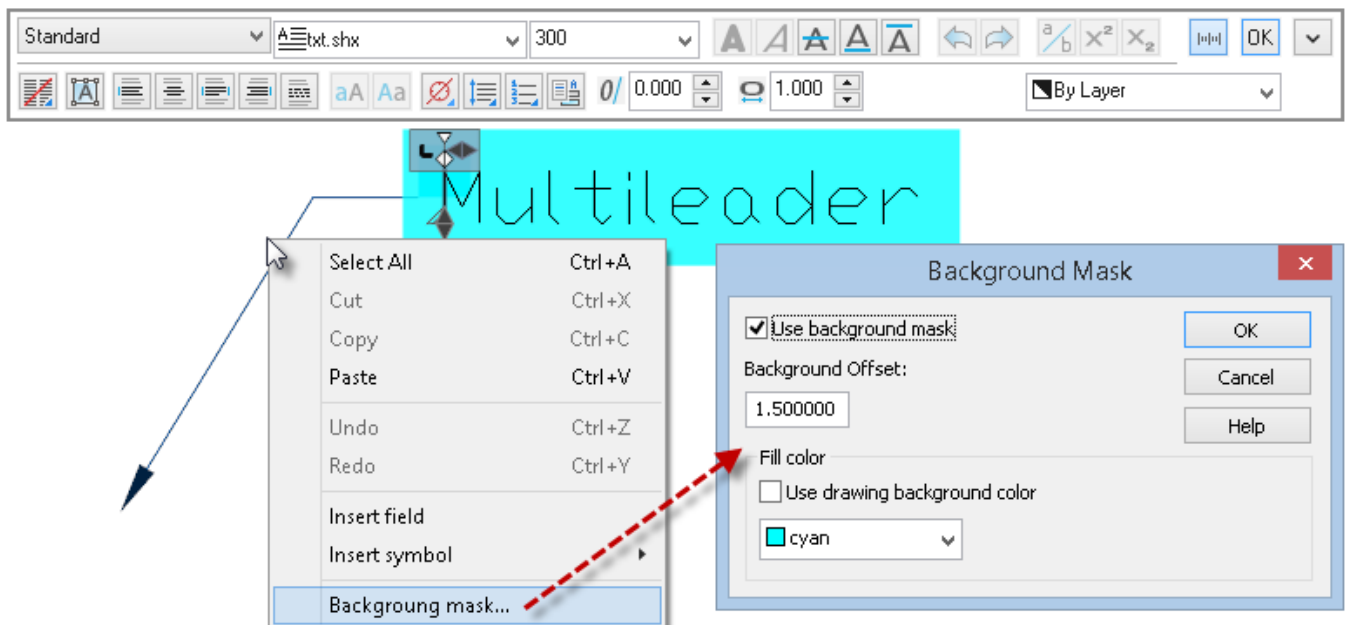

In the dialog that opens, configure the parameters.

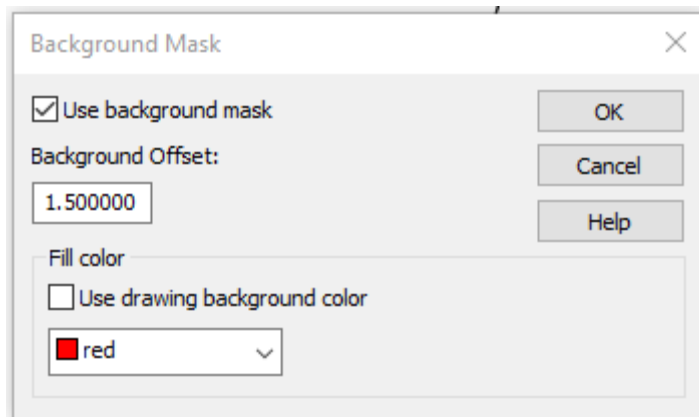

**Options:**

**Use Background Mask**

Whether or not to hide the background of multiline text.

## Background Offset

The size of the mask margins around the text area.  
 The coefficient value is tied to the height of the text. If the coefficient value is 1, then the size of the mask corresponds to the size of the text area. With a value of 1.5, the background extends out of the text area by a distance equal to half the height of the text. Cannot be less than 1.

Below is the result for values 1 and 2.8.

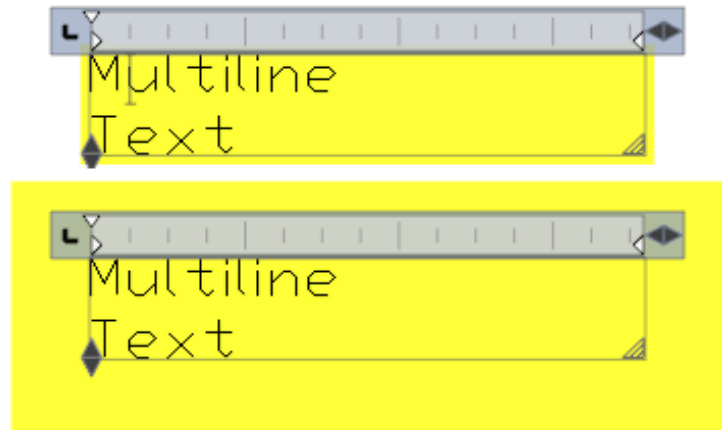

## Fill color

Mask color. Use the current background color or set your own.

To display the text area mask frame on the screen, in the **Properties** bar, in the **Text** group, for the **Text frame** property, select **Yes** from the drop-down list:

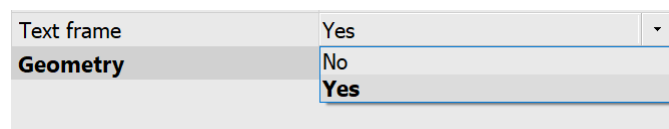

## Editing Text

Text objects can be edited like other nanoCAD objects: rotated, removed, copied etc.

When selecting a text object, the text area is highlighted with grips:

single line text

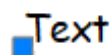

multiline text

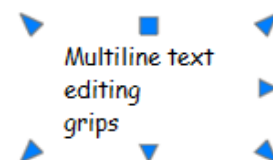

The rectangular grip is basic and is used to change the text object location.

Multiline text corner grips change the size of the text area.

Triangular grips on the faces of a text object allow you to symmetrically change the width or height of the area:



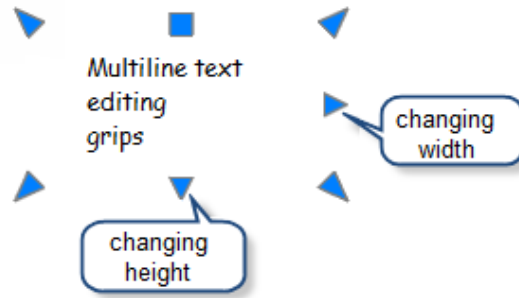

The location of grips depends on the preset text alignment type.

If you are editing rotated texts – you can specify should be all drawing rotated or only edited text in **Options – Text settings - Rotate text in edit mode**.

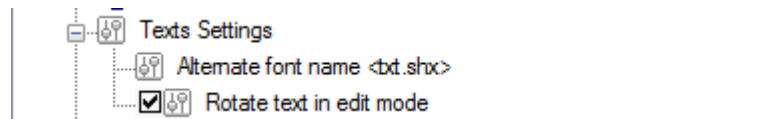

If this option is tuned on – only text object will be rotated, otherwise all drawing will be rotated. The properties of text objects can be changed in the **Properties** panel.

**NOTE:** It is only possible to change single-line text properties in the **Properties** panel.

## Justification of the Text Objects



Ribbon: **Annotate - Text** >  **Justify Text**



Menu: **Modify – Object** > **Text** >  **Justify text**



Toolbar: **Modify Object** – 



Toolbar: **Text** – 





Command line: **JUSTIFYTEXT**



The command changes the alignment, but does not change the position of single-line or multiline text in the drawing (only the number and position of the grips are changed).

To do this you should first select the text object and then specify the required type of justification in the **Properties** panel.

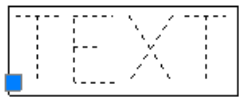
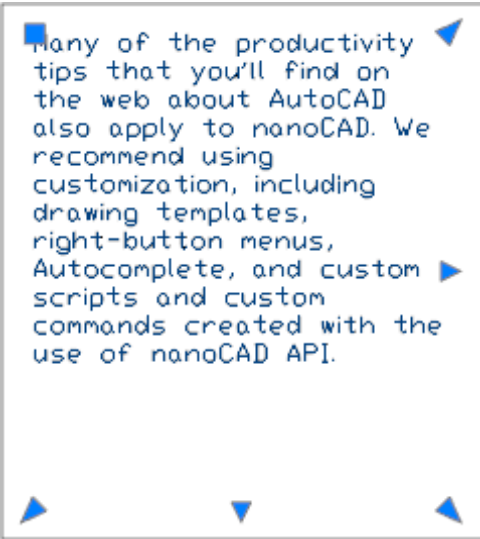
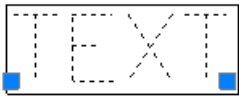
**NOTE:** Changing the alignment type with a simultaneous change in the position of the text object (for single-line text) and the text area (for multiline text) is performed by the  **Justify Text** (TJUST) command or **Justify** property on the **Properties** panel.

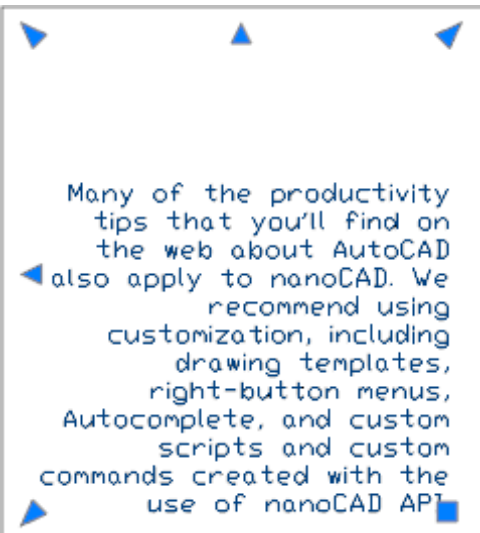
The  JUSTIFYTEXT vs. the  TJUST text alignment differences:

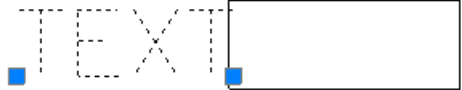

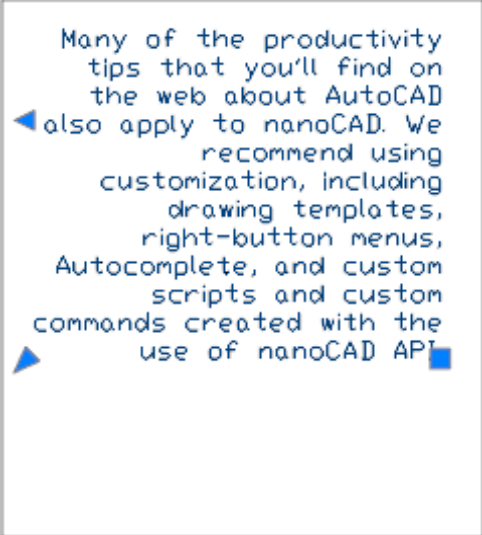

<p>Original TEXT, justified to the Left:</p> 	<p>Original MTEXT, justified to the Top Left:</p> 
<p>TEXT view when you choose the <b>Right</b> justification type from the <b>Modify</b> menu:</p> 	<p>MTEXT after applying the <b>BR</b> (Bottom Right) alignment with the  <b>JUSTIFYTEXT</b> command:</p> 



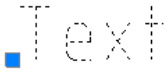
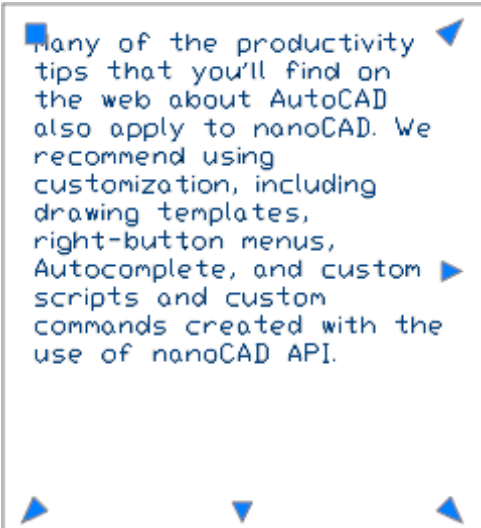

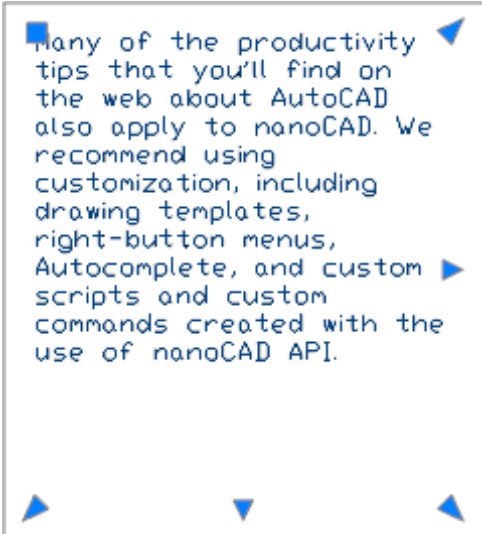
<p>TEXT view when you set the <b>Right</b> justification type in the <b>Properties</b> panel:</p> 	<p>MTEXT after applying the <b>BR</b> (Bottom Right) alignment with the  <b>TJUST</b> command:</p>  
---	---

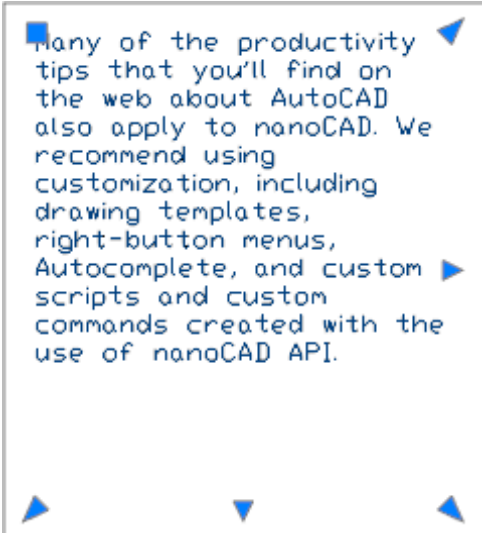

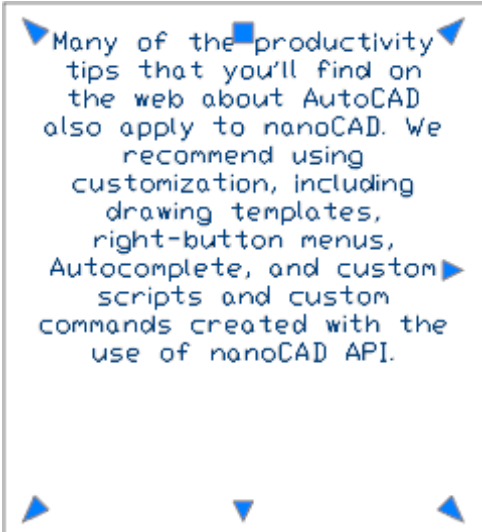
Start the  JUSTIFYTEXT command and select the text object on the drawing. Specify the type of justification in the command line or the context menu.

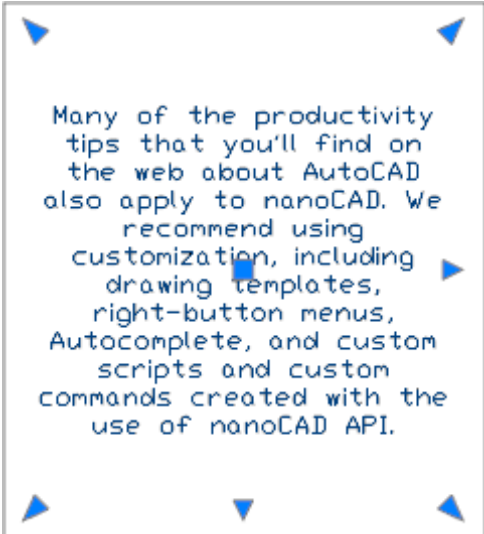

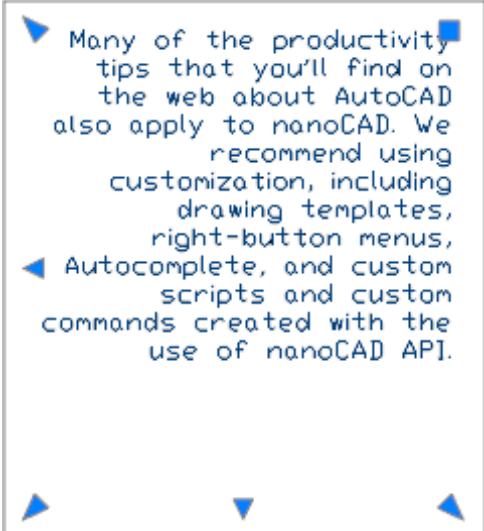
**Options:**

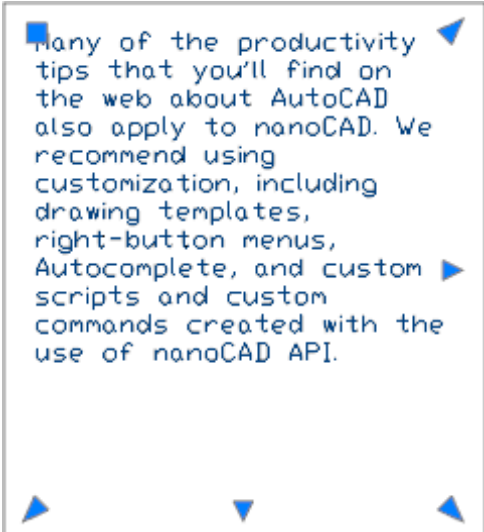

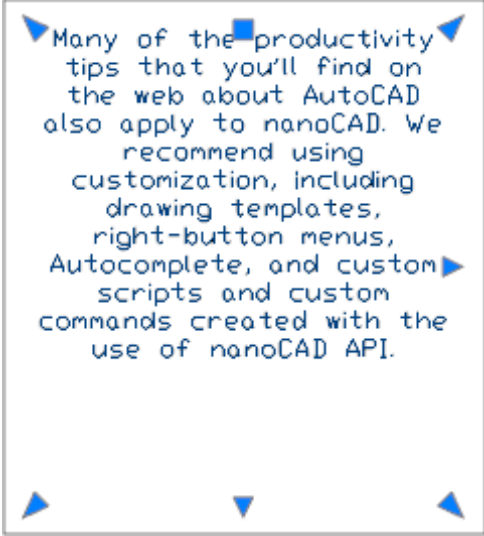
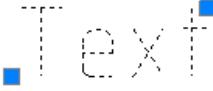
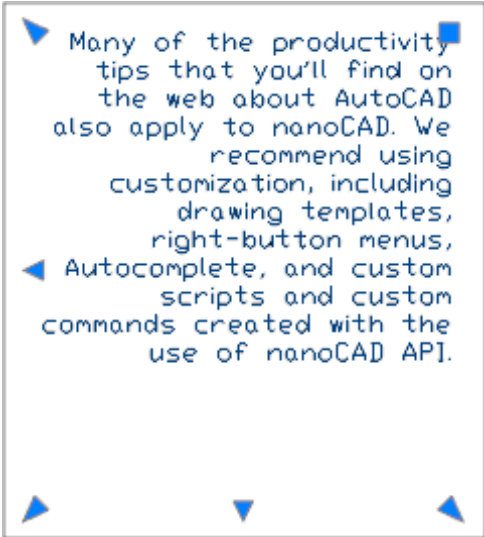
<p><b>Left</b></p>			<p>Left-justifies the text at the baseline.</p>
--------------------	---	--	---

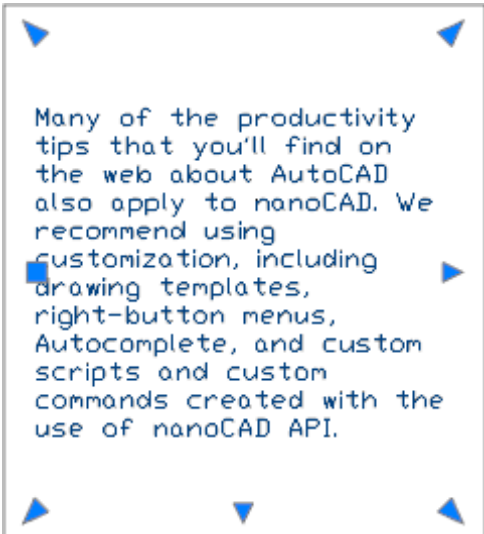
<p><b>Aligned</b></p>			<p>Inscribes text between two points. The height and width of each character are calculated automatically so that the text exactly fits into the specified area. The character height is changed.</p>
<p><b>Fit</b></p>			<p>Inscribes text between two points. The width of each character is calculated automatically so that the text exactly fits into the specified area. The character height is not changed.</p>
<p><b>Center</b></p>			<p>Aligns text from the horizontal center of the baseline, which you specify with a point.</p>

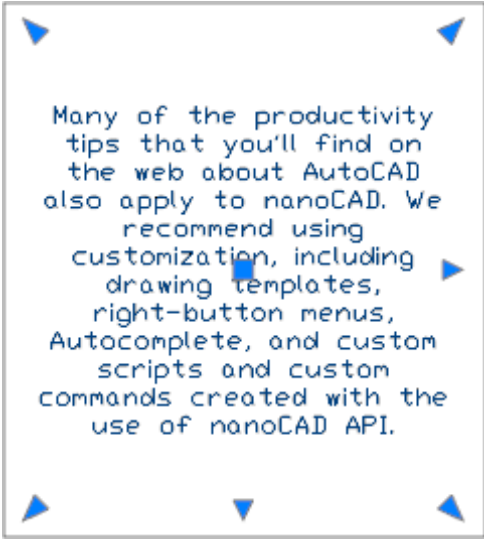
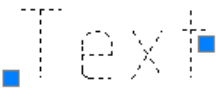
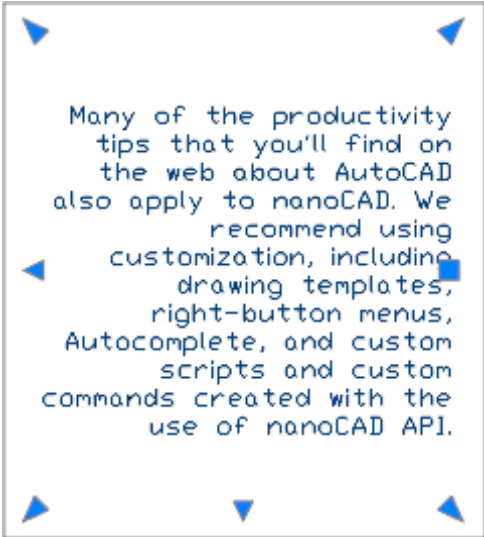
<p><b>Middle</b></p>			<p>Aligns text at the horizontal center of the baseline and the vertical center of the height you specify.</p>
<p><b>Right</b></p>			<p>Right-justifies the text at the baseline</p>
<p><b>TL (Top Left)</b></p>			<p>Left-justifies text at a point specified for the top of the text.</p>

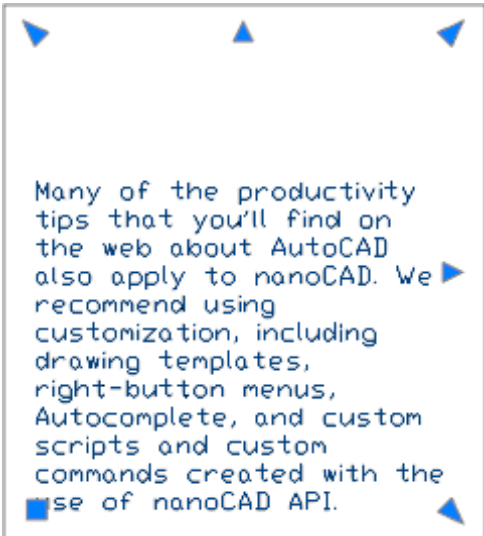
<p><b>TC (Top Center)</b></p>			<p>Centres text at a point specified for the top of the text.</p>
<p><b>TR (Top Right)</b></p>			<p>Right-justifies text at a point specified for the top of the text.</p>
<p><b>ML (Middle Left)</b></p>			<p>Left-justifies text at a point specified for the middle of the text.</p>

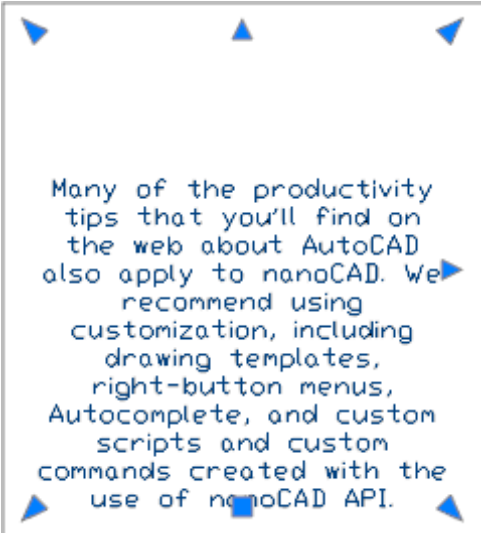
<p><b>MC (Middle Center)</b></p>			<p>Centres the text both horizontally and vertically at the middle of the text.</p>
<p><b>MR (Middle Right)</b></p>			<p>Right-justifies text at a point specified for the middle of the text.</p>
<p><b>BL (Bottom Left)</b></p>			<p>Left-justifies text at a point specified for the baseline.</p>

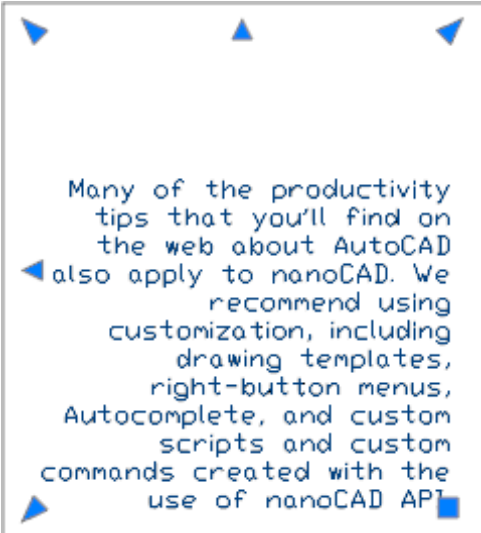

<p><b>BC (Bottom Center)</b></p>			<p>Centres text at a point specified for the baseline.</p>
<p><b>BR (Bottom Right)</b></p>			<p>Right-justifies text at a point specified for the baseline.</p>

## Editing the Content of the Text Objects

 Ribbon: **Annotate - Text** >  **Edit Texts**

 Menu: **Modify - Object** > **Text** >  **Edit**

 Toolbar: **Modify Object** - 

 Toolbar: **Text** - 

 Command line: **DDEDIT, ED**

The command for editing singleline and multiline text objects.

The command can also be called by double-clicking the left mouse button on a text object if the corresponding parameters are set to **No** in the **nanoCAD Design Settings** dialog box (**PARAMS**):

**Main options** tab, **Edit - By double-click** section **Regular texts** and/or **Multi-texts** parameter.



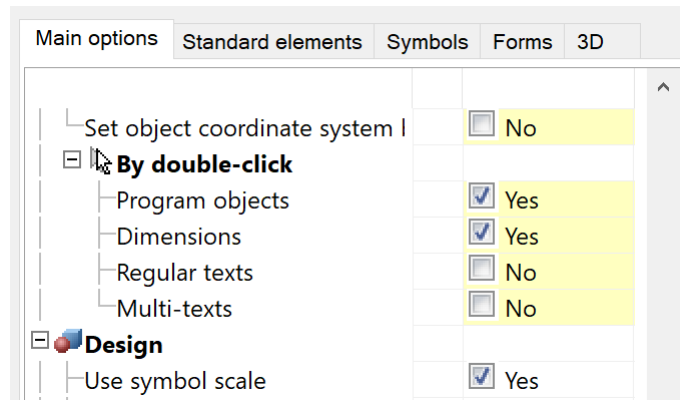

## Editing Single Line Text

You can also start the **Edit** command from the context menu previously selected the text line in the document.

The command allows you to edit the content of a single-line text directly on the drawing. The content of the selected single-line text is selected and highlighted automatically to completely edit the text. If necessary, you can insert or delete single characters or fragments within the line. For more convenient editing, use the context menu:

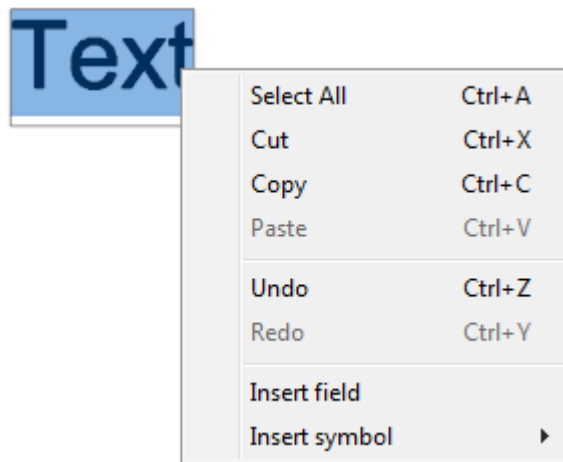

### Context menu options:

<b>Select all</b>	The entire text line will be selected.
<b>Cut</b>	Cuts the selected text to the clipboard.
<b>Copy</b>	Copies the selected text to the clipboard.
<b>Paste</b>	Pastes text from the clipboard.
<b>Undo</b>	Undoes the last action.
<b>Redo</b>	Redoes the previously undone action.
<b>Insert field</b>	Inserts a field.
<b>Insert symbol</b>	Inserts a symbol. Available symbols: <ul style="list-style-type: none"> <li>• <b>Degrees (%%d)</b></li> <li>• <b>Plus/Minus (%%p)</b></li> <li>• <b>Diameter (%%c)</b></li> </ul>

Pressing **CTRL+ENTER** or clicking on the drawing outside the text line field confirms the changes made and ends editing.

To complete editing without saving changes, press **ESC**.

**NOTE** Pressing **ENTER** splits the text string into two lines, each of which is converted into a separate text object upon the command completion.

You can also edit the single-line text in the drawing by double-clicking (if **No** is chosen for the **Regular texts** option of the **Settings nanoCAD Int** dialog box on the **Main options** tab of the **By double-click** section (the **Tools** menu – **Design Settings**)).

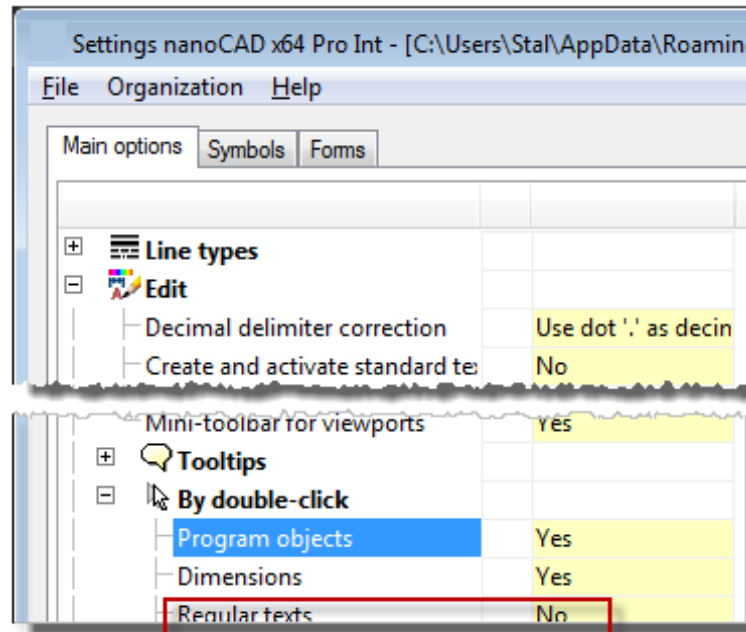

Press **CTRL** + **ENTER** or click on the drawing out of the single-line text to confirm changes and finish the editing.

To finish the editing without saving changes, press **ESC**.

**NOTE:** Press **ENTER** to split the single-line text into two lines, each of which is transformed into a separate text object after the command end.

You can edit not only text content, but also the options in the **Text settings** dialog box (if **Yes** is chosen for the **Regular texts** option of the **Settings nanoCAD Int** dialog box on the **Main options** tab of the **By double-click** section (the **Tools** menu – **Advanced Settings**)). The **Text settings** dialog box can be opened:

- by double-clicking on the text,
- by right button clicking with **CTRL** pressed on the text,
- by moving the cursor over the text and clicking the right button,
- by the **edit** and **fedit** commands.

The **Text settings** dialog box:

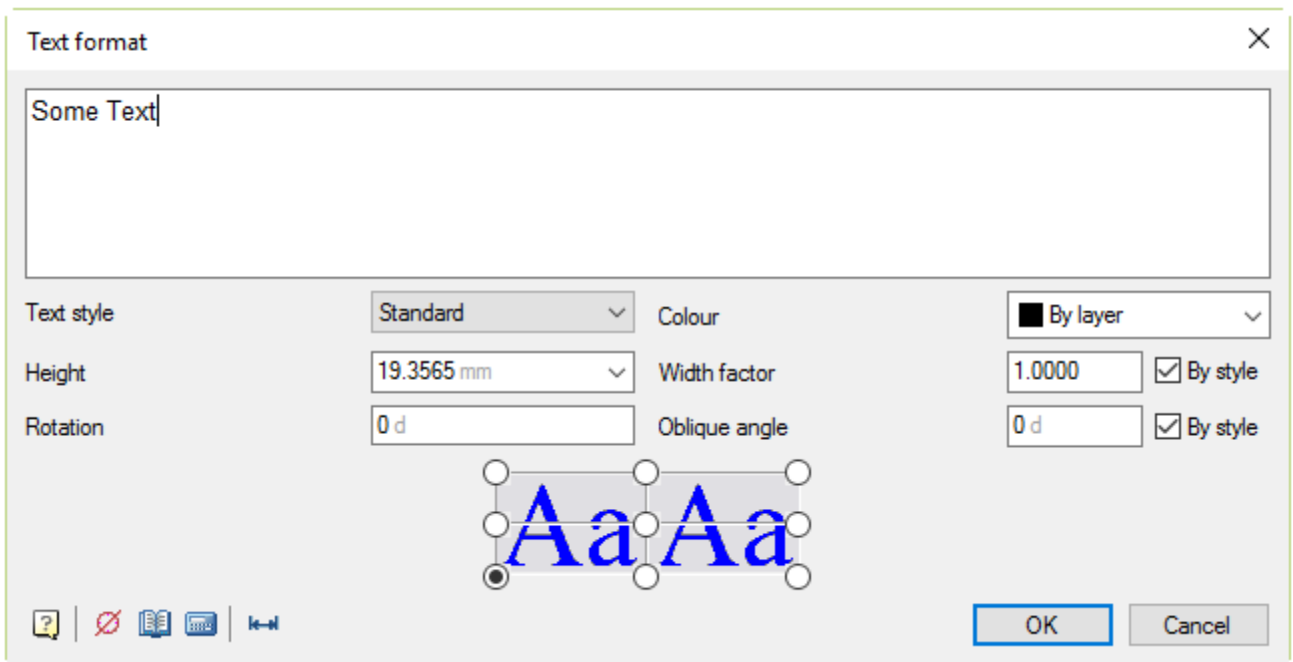

### Options:

<b>Text field</b>	Field for display and editing of the text line content.
<b>Text style</b>	Drop-down list to select the text style.
<b>Color</b>	Drop-down list to select the color of the text line.
<b>Height</b>	Drop-down list to select the height of the characters. Keyboard input is also possible.
<b>Width factor</b>	Sets the character spacing. Entering a value less than <i>1.0</i> condenses the text. Entering a value greater than <i>1.0</i> expands it.
<b>Oblique</b>	Sets the oblique angle of the text.

By style

The fields display/specify the compatibility of the width factor and oblique of the edited text symbols by the value set in the text style.

For text in which the width factor and/or oblique of the symbols correspond to the specified text style, the check boxes are selected in these fields:

Width factor	<input type="text" value="1"/>	<input checked="" type="checkbox"/> By style
Oblique	<input type="text" value="0"/>	<input checked="" type="checkbox"/> By style

If the width factor and/or oblique of the symbols does not correspond to the specified text style, the check boxes are not selected:

Width factor	<input type="text" value="0.75"/>	<input type="checkbox"/> By style
Oblique	<input type="text" value="15"/>	<input type="checkbox"/> By style

The current values of the editable text are displayed in the input fields for the width factor and oblique.

To set the width factor and oblique for the editable text to the values which correspond to those set in the text style, it is necessary to select the check boxes. Values are changed automatically:

Width factor	<input type="text" value="1"/>	<input checked="" type="checkbox"/> By style
Oblique	<input type="text" value="0"/>	<input checked="" type="checkbox"/> By style



Text justifying tool. Select text origin point.

See the [Justify Text](#) command for more information about text justifying.

 **Take from notes**

Opens the [Notepad](#).

 **Calculate**



Opens the [Calculator](#).

 **Fit text**

Runs the [Text Fit](#) command.

The **Insert special symbol**  icon opens an additional menu that allows you to select and insert the special symbols into the current text line:



The buttons , ,  of this menu, in turn, also open

Menus of some mathematical and other symbols

Uppercase Greek letters menu

Lowercase Greek letters menu

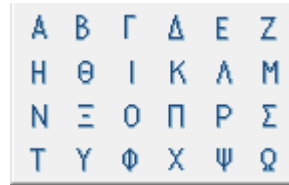

**NOTE:** Special characters are displayed correctly only with correct fonts. When you are using a TrueType, question marks or blocks may be displayed instead of the special characters.

### To insert symbols:



1. Place the cursor in the required position in the text line.
2. Click the Insert special symbol  icon.
3. Select the required symbol.
4. When you click on the symbol, the additional menu will be closed and the symbol will be inserted automatically at the current position of the cursor in the text line.

### Editing Multiline Text

 Ribbon: **Annotate - Text** >  **Edit Texts**

 Menu: **Modify - Object** > **Text** >  **Edit**

 Toolbar: **Modify Object** - 

 Toolbar: **Text** - 

 Command line: **DDEDIT, ED, MTEXTEDIT**

When you run the command and select a multiline text for editing, the same dialog box of the text editor when creating multi-line text opens (for more information, see the «**Multiline text**» section).

At the end of the work, the multiline text editing command is automatically launched again. The final completion of the work is carried out by pressing the **ESC** key. You can switch from multiple to single call of the command by selecting the **Single** value for the **Mode** option.

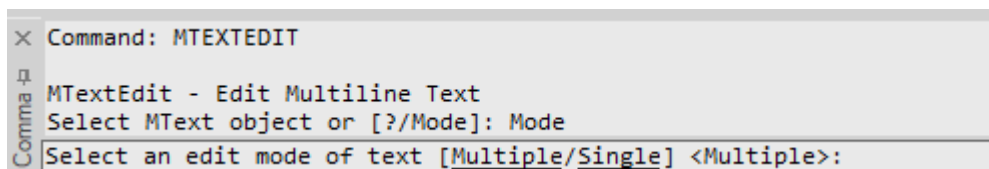

The **Mode** option sets the value for the TEXTEDITMODE system variable, which controls the automatic repetition of the MTEXTEDIT command:

- **0 - Multiple.** Enables automatic repetition of the MTEXTEDIT command.
- **1 - Single.** Specifies the MTEXTEDIT command to edit a single text object.

The **Text format** dialog box when **No** is chosen for the **Multi-texts** option of the **Settings nanoCAD Int** dialog box on the **Main options** tab of the **By double-click** section (the **Tools** menu - **Advanced Settings**) can be opened:

- by double-clicking on the text.

You can edit a multi-line text in the **Text settings** dialog box (if **Yes** is chosen for the **Multi-texts** option of the **Settings nanoCAD Int** dialog box on the **Main options** tab of the **By double-click** section (the **Tools** menu – **Design Settings**)). The **Text settings** dialog box can be opened:

- by double-clicking on the text,
- by right button clicking with **CTRL** pressed on the text,
- by moving the cursor over the text and clicking the right button,
- by the **edit** and **fedit** commands.

The **Text settings** dialog box:

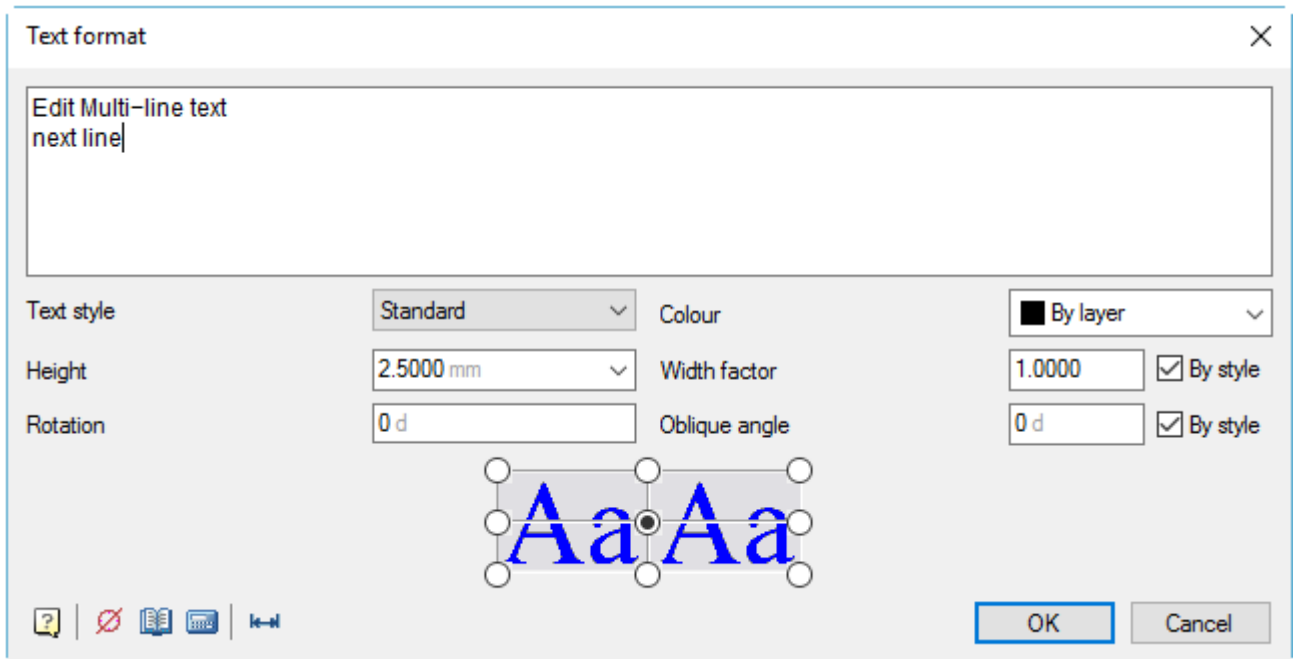

### Options:

#### Text

Field for display and editing of the text line content.

#### Color

Drop-down list to select the color of the text line.

#### Height

Drop-down list to select the height of the characters. Keyboard input is also possible.

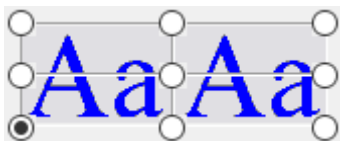

Text justifying tool. Select text origin point.

See the [Justify Text](#) command for more information about text justifying.



**Take from notes**

Opens the [Notepad](#).



**Calculate**

Opens the [Calculator](#).



**Fit text**

Runs the [Text Fit](#) command.



**Insert special symbol**

Opens an additional menu that allows you to select and insert the special symbols into the current text line (for more information, see the [Editing single-line text](#) section).







Start the command and select the multiline text. The **Text format** dialog box opens. You can also activate the editing mode, by double clicking on the multiline text.

**To edit the content and options of multiline text in the Text format dialog box:**

1. Select the text fragment in the text box and replace it with new text or type additional text. When text is selected, the following options are available in the context menu: **Select All, Cut, Copy, Paste, Undo, Redo, Insert symbol.**
2. Change the options for the selected text by using the tools of the **Text format** dialog box.
3. To end multiline text editing, press **CTRL+ENTER** or click **OK** in the **Text format** dialog box. You can also click out of the text input area on the drawing to complete text the typing.

**NOTE:** Press **ESC** to cancel the text input and finish the command.

## Arc Text

-  Ribbon: **Annotate - Text** >  **Multiline text**
-  Menu: **Draw - Text** >  **Multiline...**
-  Toolbar: **Text** - 
-  Command line: **ARCTEXT**

The command creates the **Arc Text** type object along the curve selected arc.

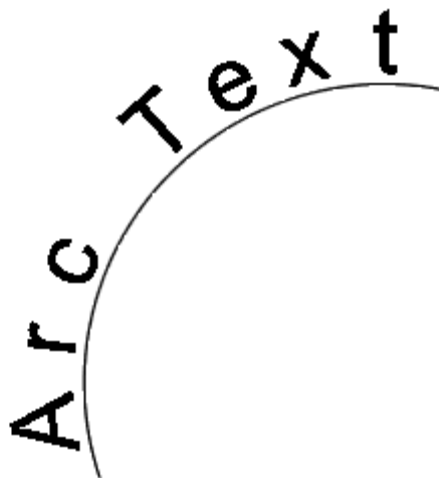

An arc text is associated with the arc along which it is built. It changes its position and stretch with the change in the length and curvature of the arc itself.

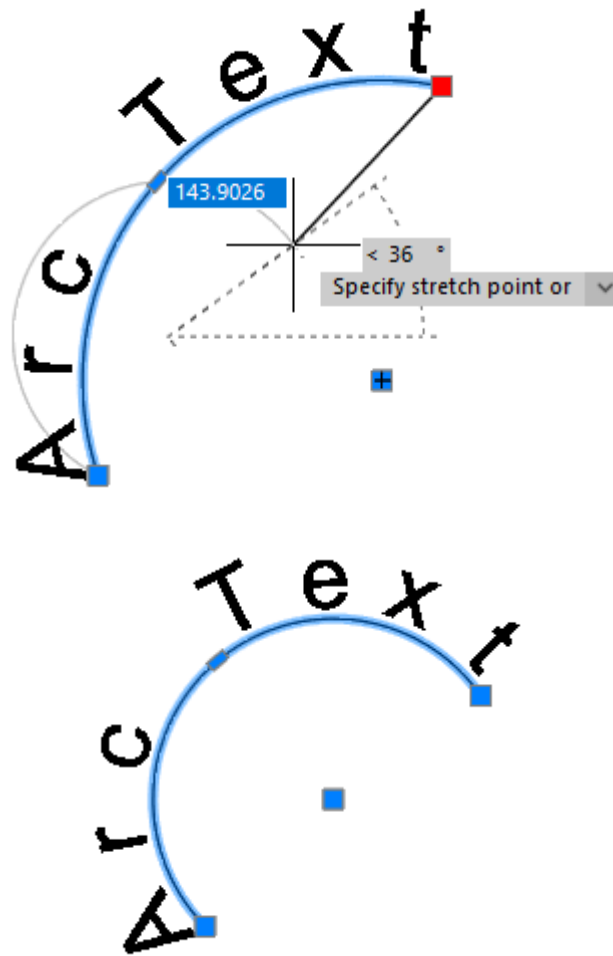

The arc text has its own grips that allow you to adjust the value of its offset above/below the arc and the offset along the arc from its left or right edge.

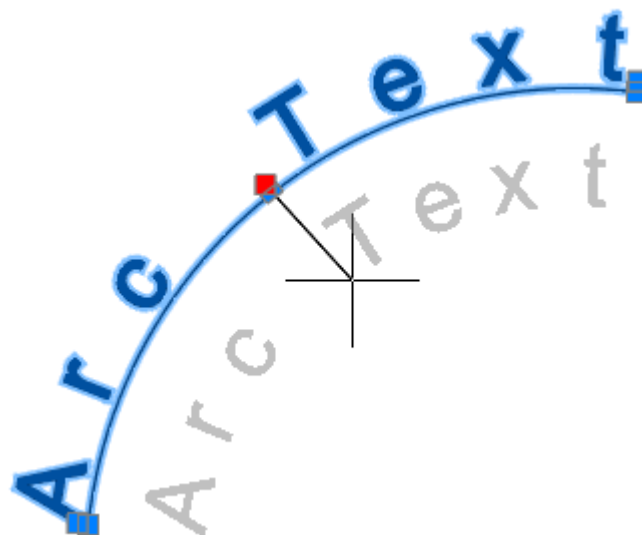

All arc text options can be edited in the **Properties** bar or in the **Arc Aligned Text Settings** dialog box, which opens by double-click on the object.

After running the command, specify the arc (**Arc** object (ARC)) along which the text should be placed.



After specifying the arc, the **Arc Aligned Text Settings** dialog box opens:

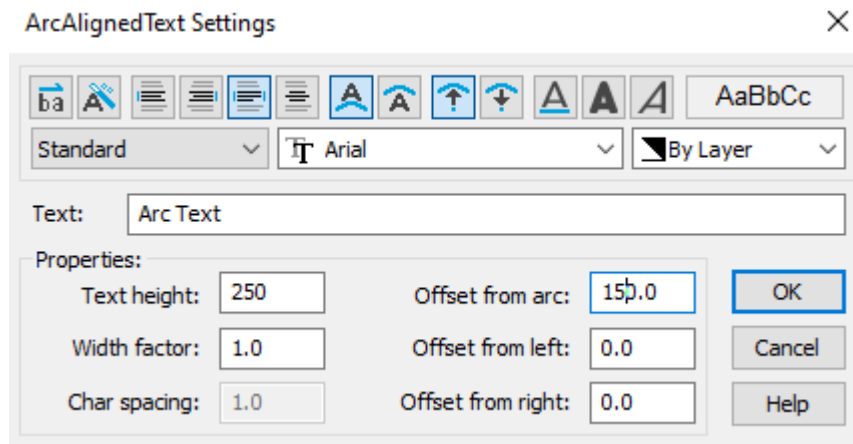

### Options:

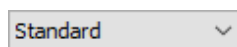

Drop-down list to select a text style.



Drop-down list to select a font file that specifies the character style.

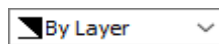

Drop-down list to select the text color.

### Aligning text lines relative to the text area



#### Reverse text reading order

Arranges text in reverse order.



#### Align left

Turns on the text alignment mode to the left edge of the text area.



#### Align right

Turns on the text alignment mode to the right edge of the text area.



#### Justified

Turns on the text alignment mode to fit the width of the text area.



#### Align center

Turns on the text alignment mode in the center of the text area.

### Text formatting



#### On convex side

Positions text on the outside of the arc at the distance specified in the **Offset from arc** parameter



#### On concave side

Positions the text on the inside of the arc at the distance specified in the **Offset from arc** parameter.



#### Outward from the center

Positions the text so that its base is closer to the center of the arc and its top is farther away.



#### Inward to the center

Positions the text so that the top of the text is closer to the center of the arc and the bottom is farther away.



#### Bold

Enables/disables bold characters. The parameter is only available for TrueType fonts.



#### Italic

Enables/disables italic characters. The parameter is only available for TrueType fonts.



#### Underlined

Enables/disables character underlining.

### Other parameters

<b>Text height</b>	Specifies the text height.
<b>Width factor</b>	Specifies the compression ratio for text characters. More than one - character expansion. Less than one - character compression.
<b>Char spacing</b>	Specifies spacing between characters.
<b>Offset from arc</b>	Specifies the distance from the arc line to the nearest edge (top or bottom) of the text line. This parameter is also controlled by the central text grip.
<b>Offset from left</b>	Specifies the indent of a text line from the left end of the arc. This parameter is also controlled by the left text grip.
<b>Offset from right</b>	Specifies the indent of a text line from the right end of the arc. This parameter is also controlled by the right text grip.

## Creating a Text Style



Ribbon: **Annotate - Text** > 



Menu: **Format** -  **Text Style ...**



Toolbar: **Styles** - 



Toolbar: **Text** - 



Command line: **ST, STYLE, TEXTPROPCMD**

The text style is a convenient tool that creates text objects using different fonts, font size, oblique angle, orientation, and other text characteristics.

You can create and use several text styles in one drawing. Each text object in the drawing is created using the current text style. If you want to create text using a different text style, you can make another text style current.

Except for the default *Standard* text style, you must create any text style that you want to use.

You can modify an existing text style in the **Text Style** dialog box by changing the settings.

A text style name can be up to 255 characters long. It can contain letters, numbers, and the special characters: dollar sign (\$), hyphen (-), and underscore (\_).

By default, the text styles are automatically named *Style1*, *Style2*, *Style3*, etc.

Created text styles are saved with the drawing file.

You can remove unused text styles from your drawing by deleting them from the **Text Style** dialog box or with the **Purge** command (the **File** menu - **Drawing Utilities**).

**NOTE:** The *Standard* text style cannot be removed.

**NOTE!** Changing the **Upside Down** and **Backwards** options has no effect on multiline text objects.

The **Text Style** dialog box allows you to set the current text style, create new text styles, and change the parameters of the existing text styles (imported as a \*.dwg or \*.dwt files):

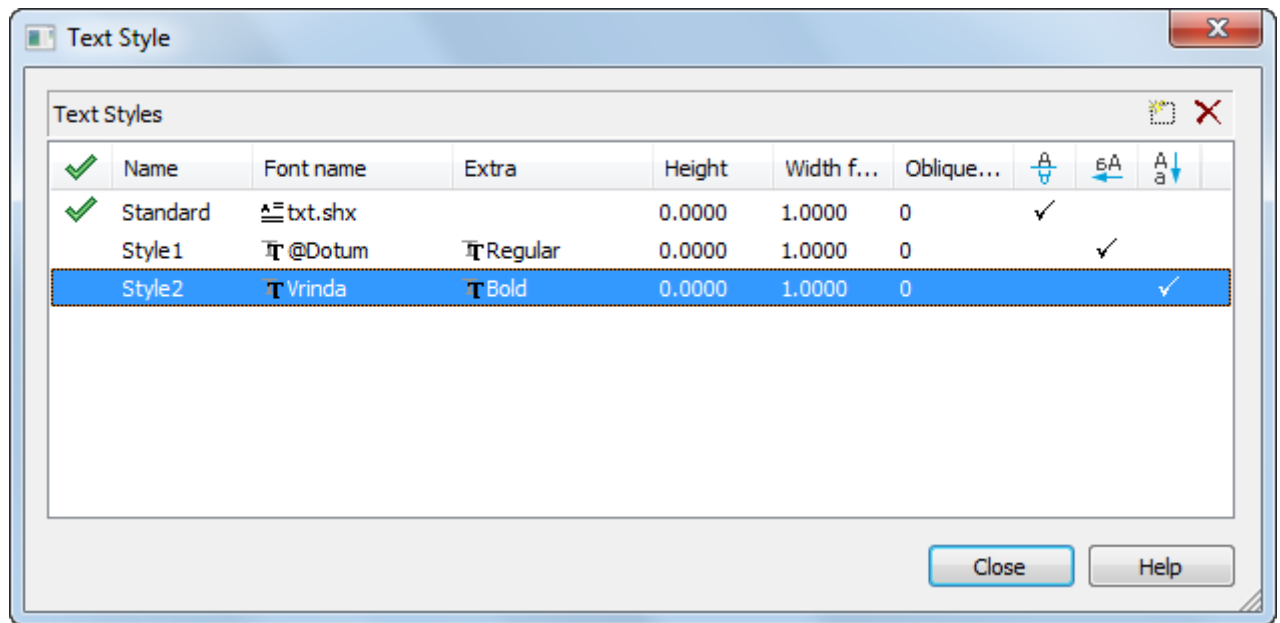

### Options:



**Add new style**

Creates a new text style.



**Delete style**

Deletes unused text style.



**Set current**

Sets the selected style as current.

**Name**

Name of text style.

**Font name**

Drop-down list to select the font

**Extra**

Drop-down list to select the text style.

The list is empty for shx-fonts.

For TTF-fonts the following types are available:

- Italic
- Normal
- Bold
- Bold Italic

**Height**

Height of the text.

**Width factor**

Sets the character spacing.

Entering a value less than *1.0* condenses the text.

Entering a value greater than *1.0* expands it.

**Oblique angle**

Sets the oblique angle of the text.



**Upside down**

Turns on/off the mode to display the characters upside down.



**Backwards**

Turn on/off the mode to display the characters backwards.





**Vertical**

Turns on/off the mode to display the characters aligned vertically. Vertical is only available if the selected font supports dual orientation.

**NOTE:** The vector fonts (\*.SHX) are marked with **S** in the **Font name** list, TrueType-fonts with **T**.



**To create a text style:**

1. Select the text style, which the new text style should be based on (the **Add new style**  icon is available).
2. Click the **Add new style**  icon. The new style with **Style1** name will be created.
3. To rename the created style, double click on the text style name, type the new name and press **ENTER**.
4. From the drop-down list select the font.
5. Specify the required text options (height, extra, oblique angle, etc.).
6. To set the created text style as the current one, double click in the left field next to the text style. The flag  in this box indicates that the style is set as the current one.
7. Click **Close** to close the dialog box.

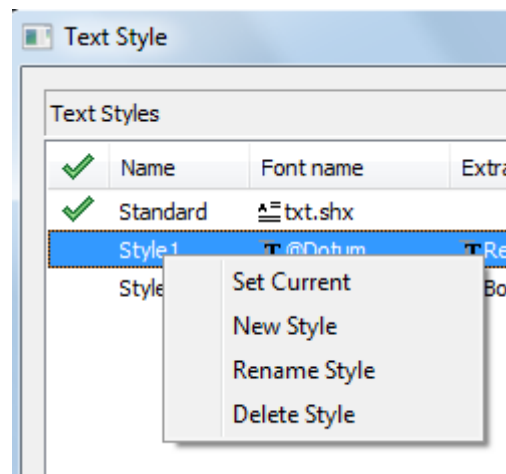







Some commands are also available in the context menu by right clicking in the field of the text styles list:



### To delete a text style:

1. Select the text style you want to delete (the **Delete style**  icon is available).
2. Click the **Delete style**  icon or select **Delete Style** from the context menu (the selected style must not be the current one).
3. Click **Close** to close the dialog box.

## Spellchecker

-  Ribbon: **Annotate – Text** >  **Spell Check**
-  Menu: **Tools** –  **Spell check**
-  Toolbar: **Text** – 
-  Menu: **View – Toolbars** > **Functional** >  **Spell check**
-  Command line: **SPELL, SP**

Check the spelling of all text objects in the drawing on request and realtime.

It is possible to work simultaneously with several documents. Spellcheck results in a previous document are not lost when switching to the next document.

The command opens **Spell Check** dialog box.

To start checking document objects for spelling errors and start tracking errors in real time, click the button **Spell Check**. To start checking document objects for spelling errors and start tracking errors in real time, click the **Check** button. To check only particular objects, first select them in the drawing field.



Misspelled texts will be underlined with a wavy line in drawing space and will also appear in the list of found errors in the bar.

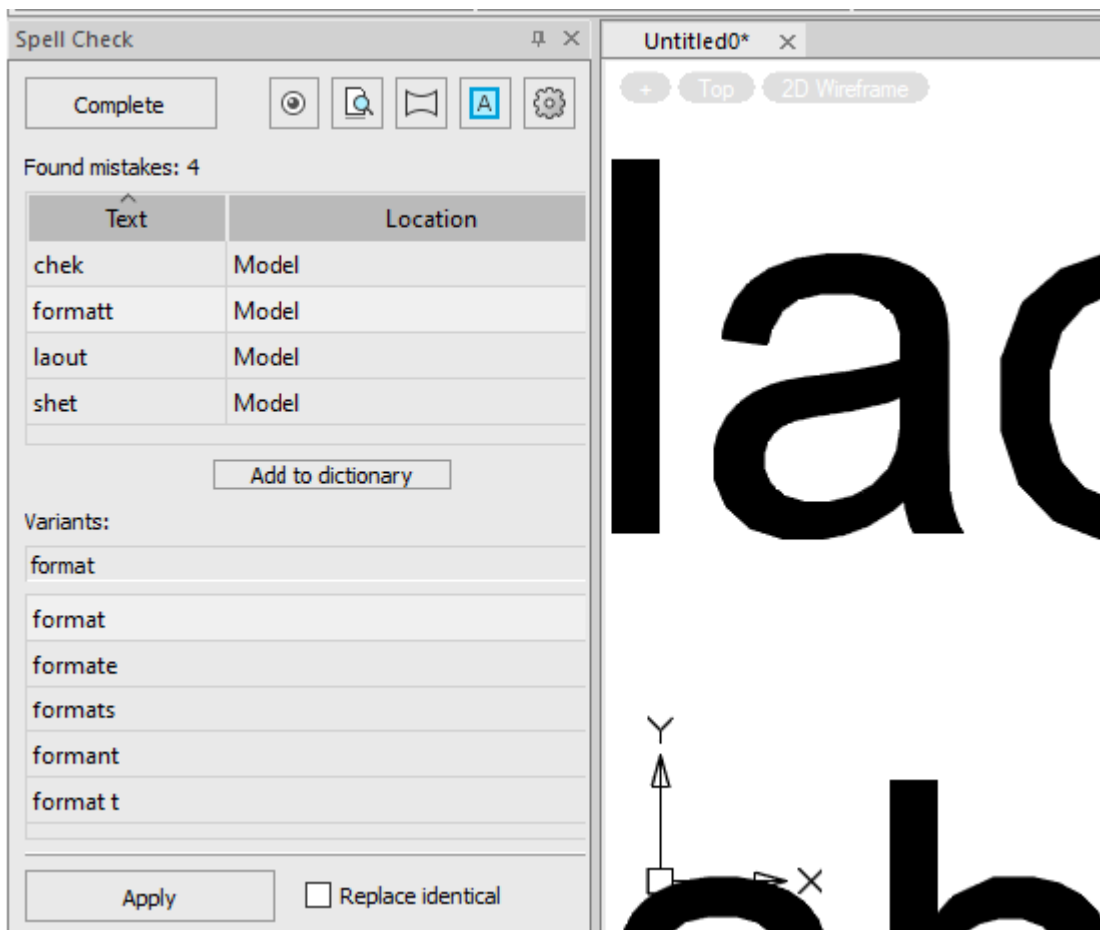

**Parameters of synchronization and visualization of texts with the mistakes found:**

 **Watch for new objects**

Tracks spelling mistakes in real time. All new and changed objects will be checked for spelling. If mistakes are found, the words will be underlined in the drawing field and added to the list of found mistakes on the panel.

Clicking the **Complete** button also disables spell tracking on new objects.

 **Check entire**

Checking the text in the model space and on all layouts of the document (not just in the current space)

## document



### Auto-pan

Enables/disables automatic navigation in the graphics area of the drawing.

When the auto-pan mode is enabled, the word selected in the list of found mistakes is automatically synchronized with the corresponding text object in the drawing. The text object is positioned in the center of the graphic area for more comfortable viewing and is marked with a frame.



### Underline

Enables/disables the mode of selecting a text with a mistake. The text selected in the dialog is marked with a dotted frame in the drawing. Other texts with mistakes are underlined with a wavy line.



### Settings

Opens the spell check settings dialog where you can:

- Add or exclude specific types of objects from the check.
- Exclude certain types of text from validation.

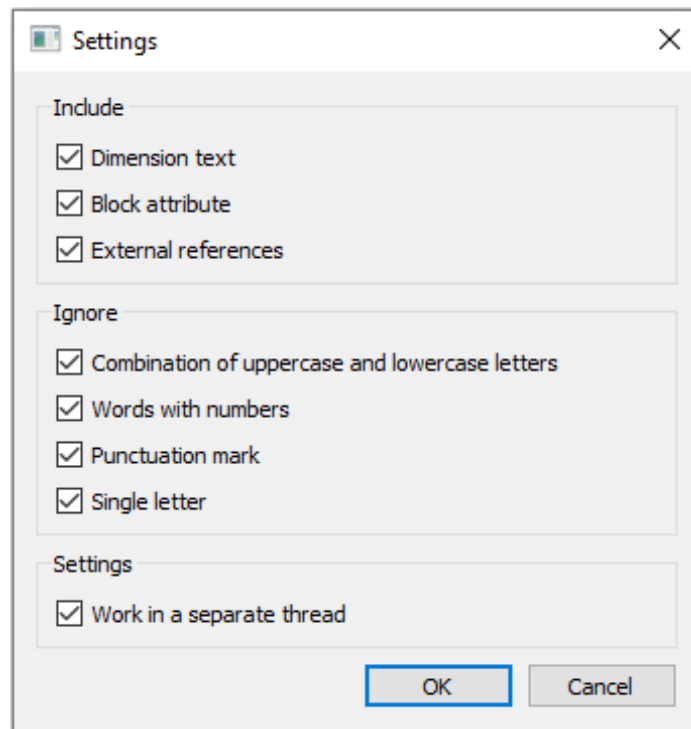

You can also configure the spelling command to run on a separate thread to process information independently of the platform thread.

## Add to dictionary

Adds the word selected from the list of found mistakes to the exclusion dictionary. After that, such a word will not be considered a mistake.

## Replace identical

Replace all found texts with this mistake with the selected option after pressing the **Apply** button.

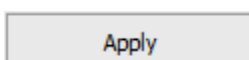

Replace the error with the selected option.

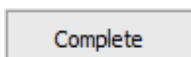

Completes a spell check session in the current document. The button changes to **Check**.

## Correct mistakes:







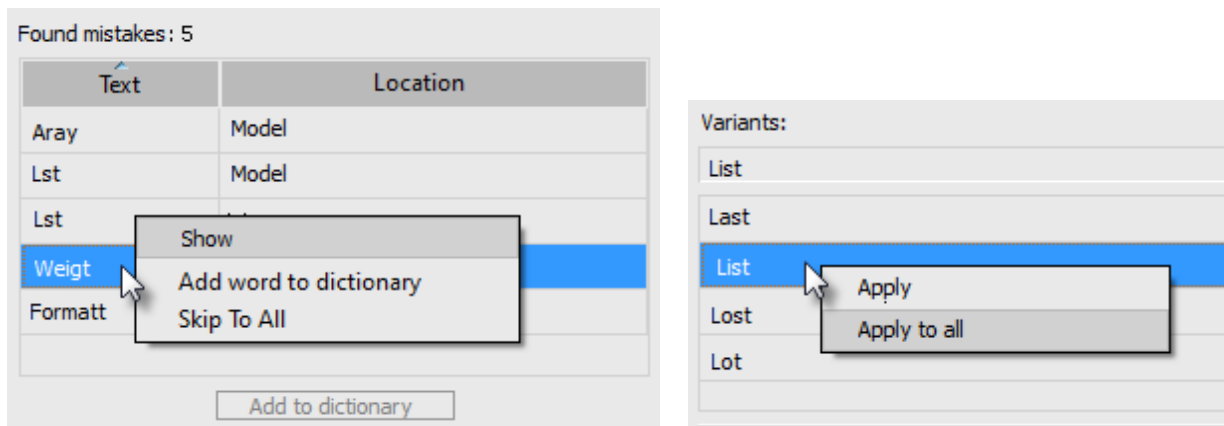

1. In the bar in the list of errors, select the text with the error.

2. In the **Variants** list of variants for replacement, select the line with the correct variant.
3. If you need to leave the word unchanged and add it to user dictionary, click **Add to dictionary**.
4. Check the **Replace identical** box, if you need to replace all found texts with this mistake to the selected variant
5. Click **Apply** to apply changes.

You can use the context menu of selected variants for mistakes or replacement. It duplicates actions available for performing with the selected element.



## Find and Replace Text

-  Menu: **Edit** -  **Find and Replace ...**
-  Toolbar: **Text** - 
-  Context menu of drawing  **Find and Replace**
-  Hot keys: **CTRL+F**
-  Command line: **FIND**

The **Find and Replace** command is used to find text in the document.

You can also start the command from the context menu:

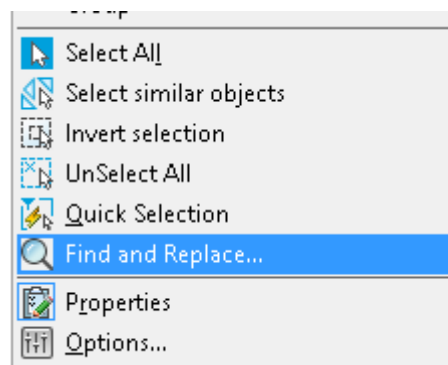

Start the command to open the **Find and Replace** dialog box:

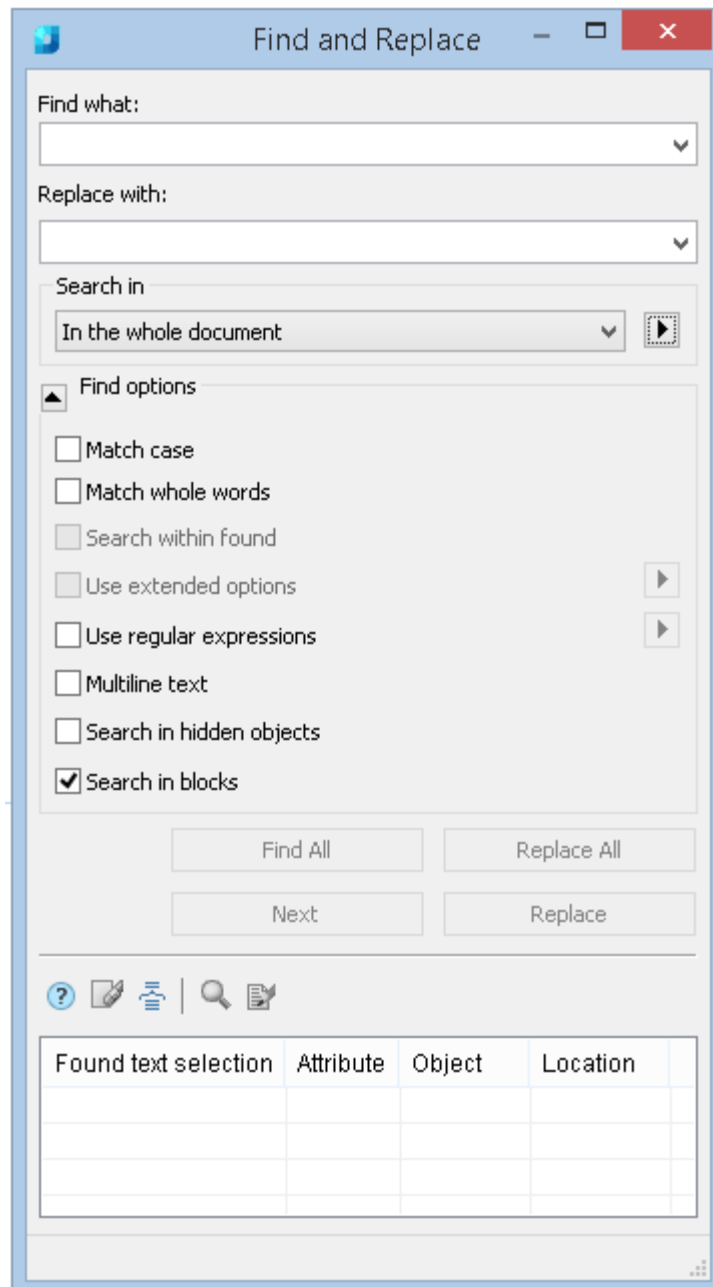

**Options:**

**Find what:**

In the **Find what** field, type the text to be searched for.

**Replace with:**

In the **Replace with** field, type the text that is required to replace the found lines.

*Look in*

Set the *Look in* parameter.

The following options are available:

- In whole document
- In current space
- In current selection

Click the icon  to open the **Quick selection** dialog box.



### Find options

or

**Match case:**

This icon maximizes/minimizes the options list.

If this is checked, the search is made to match the case of the letters.

**Match whole word:**

If this is checked, the search is made for whole words; that is letter combinations separated by stops or spaces.

**Search in found:**

This option is accessible after the line search has been made. It restricts the search range.

**Use extended options:**

To search in the object database. The option is available when searching the object database of some vertical applications.

Click the  button opposite the parameter and in the window that appears, select advanced search areas.

This option is accessible when searching in the objectsbase..

**Use regular expressions**

Enables/Disables the mode for specifying search patterns using regular expressions.

Regular expressions can be entered independently or using a list. The  button opens a window for selecting the required expression from the list:

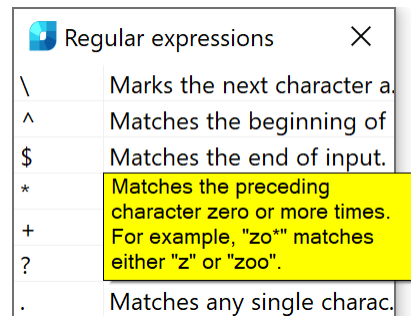

When you place the cursor on a list line, a tooltip appears with a detailed explanation.

You can use multiple regular expressions together.

An expression is entered in the search field by left-clicking on the expression from the list.

**Multi-line text:**

Switches on/off the multi-line text search mode.

When the mode is on, the **Find what** and the **Replace with** fields take the form:

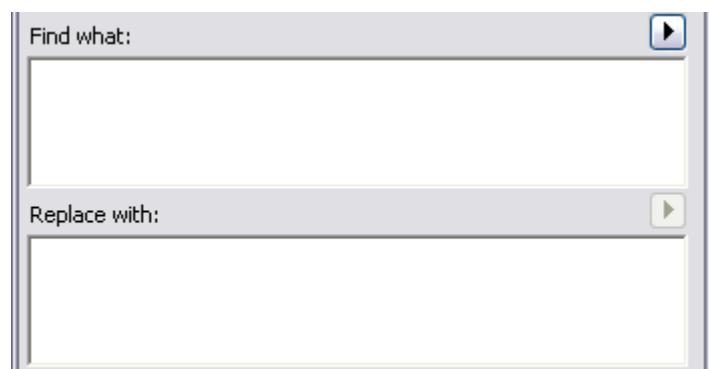

**Search in hidden objects**

Searches text in hidden objects.

**Search in blocks**

Searches text in blocks.

Find All

Starts the search procedure.

The search result will be shown in the table:

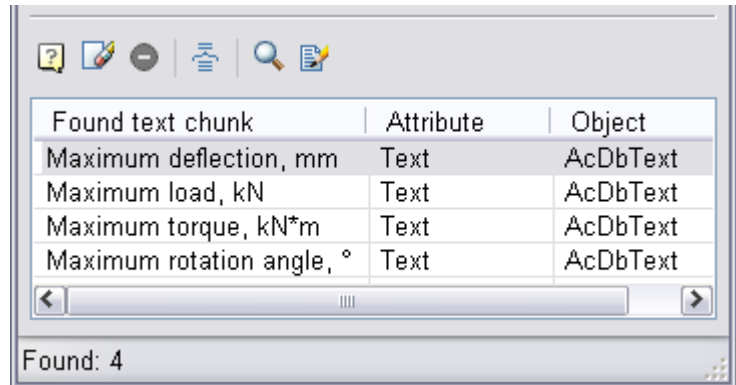

Found text chunk	Attribute	Object
Maximum deflection, mm	Text	AcDbText
Maximum load, kN	Text	AcDbText
Maximum torque, kN*m	Text	AcDbText
Maximum rotation angle, °	Text	AcDbText

Found: 4

Replaces all found fragments with the new value.

Replace All

Starts the process of consecutive replacement of the found fragments.

Replace

Passes the next found fragment in the list without replacing it with the new value.

Skip



**Clear All:**

Click this icon to clear the list of found text fragments.



**Group results by objects:**

Click this icon to group results by objects.



**Show object:**

Click this icon to show the selected text fragment in the table on the drawing or in the database of objects.



**Edit object:**

Click this icon to open the **Text settings** dialog box to edit the found text fragment on the drawing.

**NOTE:** Left-click on the headings of the table columns of the search results to sort the found text fragments:

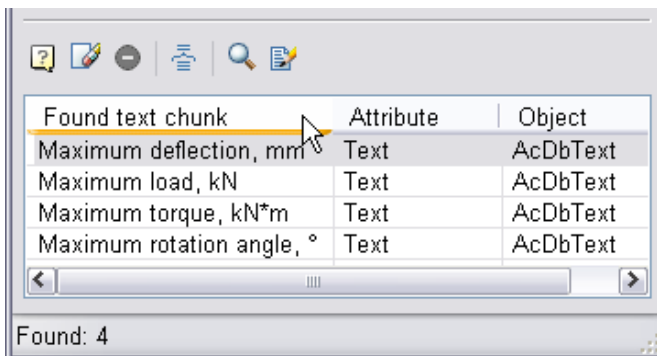

Found text chunk	Attribute	Object
Maximum deflection, mm	Text	AcDbText
Maximum load, kN	Text	AcDbText
Maximum torque, kN*m	Text	AcDbText
Maximum rotation angle, °	Text	AcDbText

Found: 4

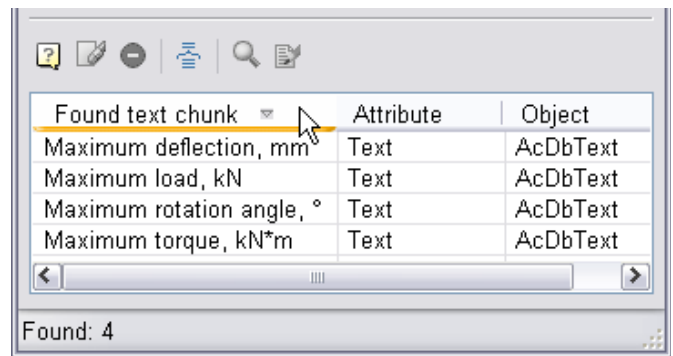



Found text chunk	Attribute	Object
Maximum deflection, mm	Text	AcDbText
Maximum load, kN	Text	AcDbText
Maximum rotation angle, °	Text	AcDbText
Maximum torque, kN*m	Text	AcDbText

Found: 4

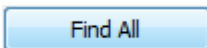
**To find and edit the text fragment on the drawing:**

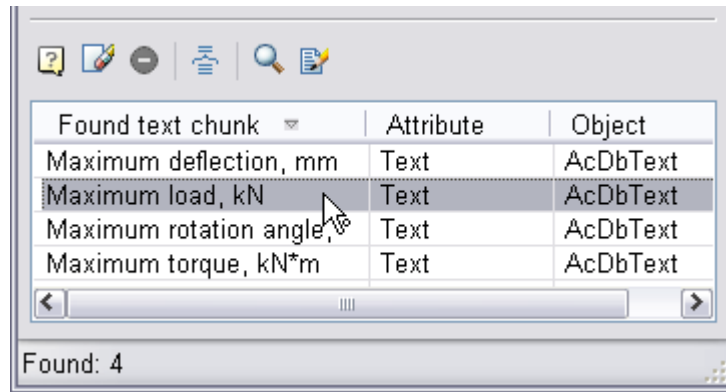
1. Click the **Find and Replace** command in the context menu.
2. Type the text, for example, *maximum*, into the **Find what** field.
3. Click the button .
4. Select the required line in the table of search results:



5. Double click on the required line, or click the **Show object**  icon, or select the **Show object** command from context menu:

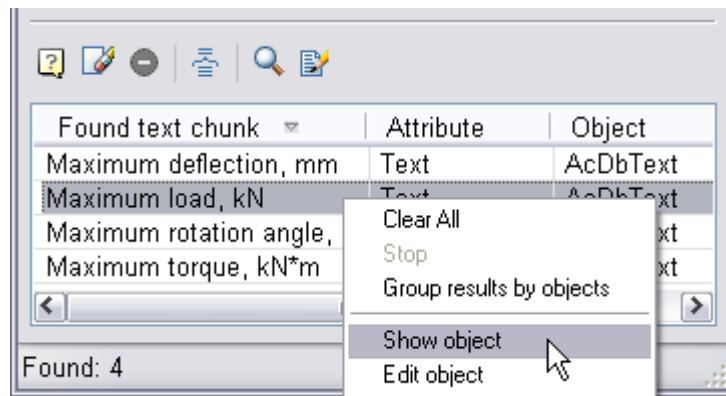

6. As a result, there is auto-panning of the found fragment that contains the selected text on the drawing:

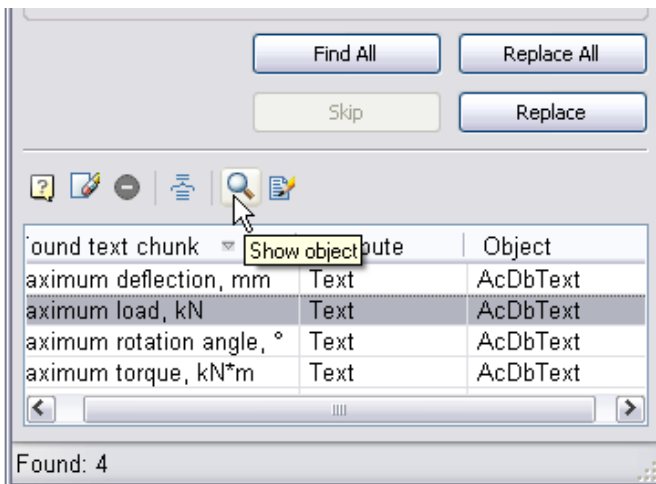

*Parameter*

*Maximum deflection, mm*

*Maximum rotation angle, °*

*Maximum torque, kN\*m*

*Maximum load, kN*

*Shaft weight, kg*

*Length, mm*

7. Click the **Edit object**  icon or select the **Edit object** command from the context menu to open the **Text settings** dialog box:

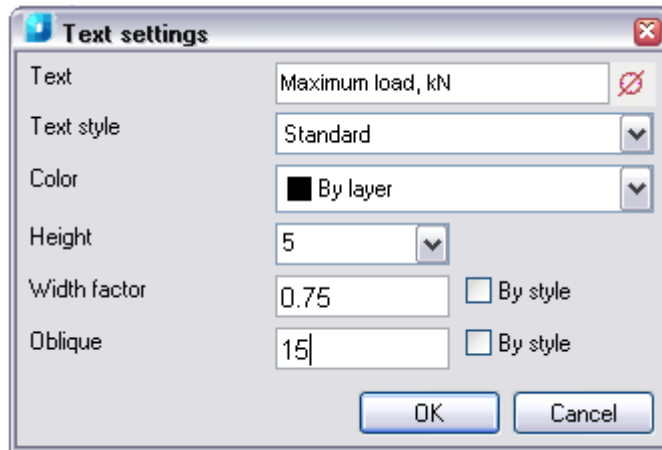

8. Type the required changes and click **OK**.

## Convert Text to Multiline Text



Ribbon: **Annotate – Text** >  **Convert Text to Multiline Text**



Menu: **Modify – Advanced Tools** >  **Convert text to Multiline Text**



Command line: **TEXT2MTEXT, T2MT**

The command converts the selected single-line text objects to the multiline text.

During conversion, the single-line text objects are removed from the document and inserted into a single multiline text object.

After conversion, values of the height, color, width factor and oblique of the single-line text objects are saved in the multiline text:

Before conversion	After conversion
Text height 250	Text height 250
Text height 200	Text height 200
Text Color	Text Color
Width factor	Width factor
Oblique	Oblique

### Command options:

 Calls additional options to select the objects.

### Command prompts:

Select text objects or  
[?]:

Select the single-line text objects.

Select text objects or  
[?]:

Press **ENTER** to finish the command.

## Justify Text



Ribbon: **Annotate – Text** >  **Justify Text**



Menu: **Modify – Advanced tools** >  **Justify text**



Command line: **TJUST**

Changes the justification point of a text object without moving the text.

**NOTE:** Changing the type of alignment without changing the position of the text or the text area in the drawing is performed by the  **Justify Text** (JUSTIFYTEXT) command.

The command is useful when you want to alter the position of the Insert object snap (INSertion) for text objects without moving the text.

1. Select text object.
2. Start the **Justify Text** (TJUST) command.
3. Select the desired type of justifying in the command line or context menu.

### Command options:

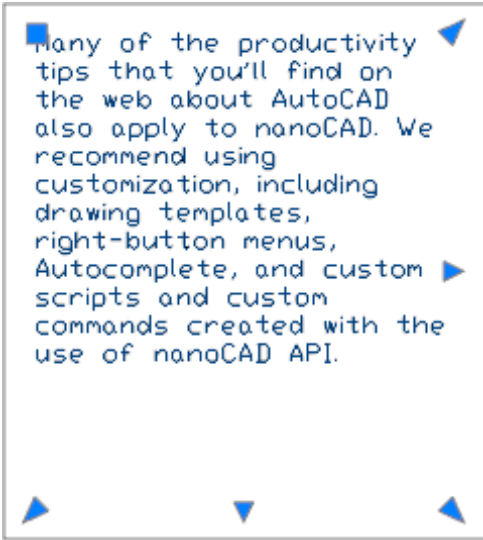
Start	Justify text by the left margin.
Center	Justify text by the horizontal center.
Middle	Justify text by the horizontal and vertical center.
Right	Justify text by the right margin.
TL	Justify text by the top and left margins. 
TC	Justify text by the top margin and horizontal center.

	<p>Many of the productivity tips that you'll find on the web about AutoCAD also apply to nanoCAD. We recommend using customization, including drawing templates, right-button menus, Autocomplete, and custom scripts and custom commands created with the use of nanoCAD API.</p>	
TR	<p>Justify text by the top and right margins.</p> <p>Many of the productivity tips that you'll find on the web about AutoCAD also apply to nanoCAD. We recommend using customization, including drawing templates, right-button menus, Autocomplete, and custom scripts and custom commands created with the use of nanoCAD API.</p>	
ML	<p>Justify text by the left margin and vertical center.</p> <p>Many of the productivity tips that you'll find on the web about AutoCAD also apply to nanoCAD. We recommend using customization, including drawing templates, right-button menus, Autocomplete, and custom scripts and custom commands created with the use of nanoCAD API.</p>	
MC	<p>Justify text by the vertical center and middle of horizontal.</p>	

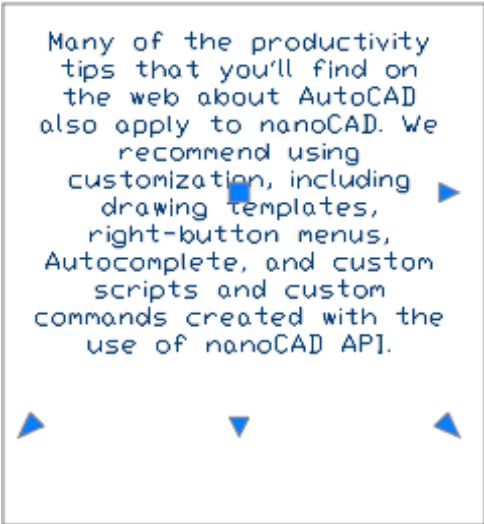
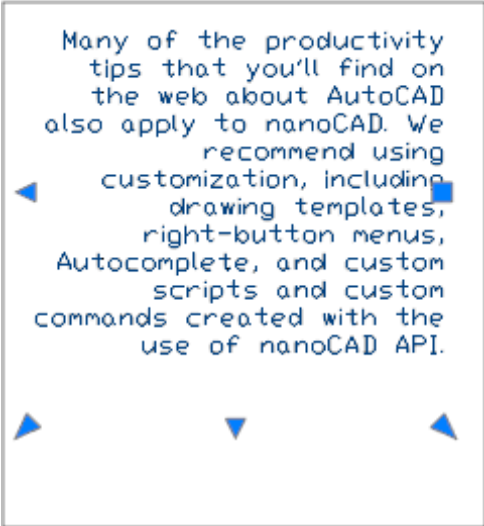
	 <p>Many of the productivity tips that you'll find on the web about AutoCAD also apply to nanoCAD. We recommend using customization, including drawing templates, right-button menus, Autocomplete, and custom scripts and custom commands created with the use of nanoCAD API.</p>
MR	<p>Justify text by the right margin and vertical center.</p>  <p>Many of the productivity tips that you'll find on the web about AutoCAD also apply to nanoCAD. We recommend using customization, including drawing templates, right-button menus, Autocomplete, and custom scripts and custom commands created with the use of nanoCAD API.</p>
BL	<p>Justify text by the bottom and left margins.</p>

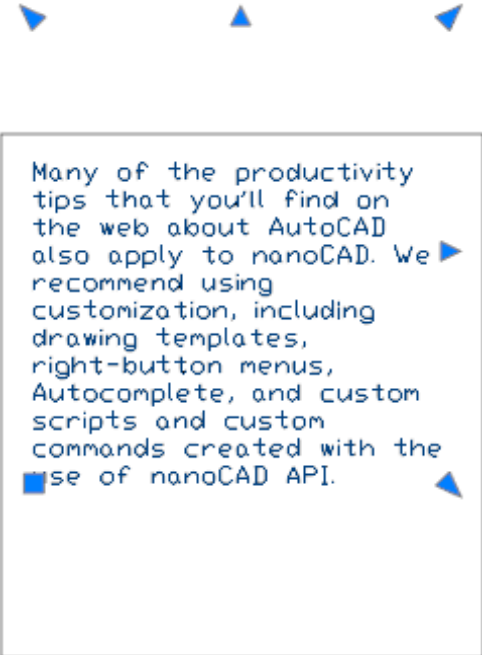
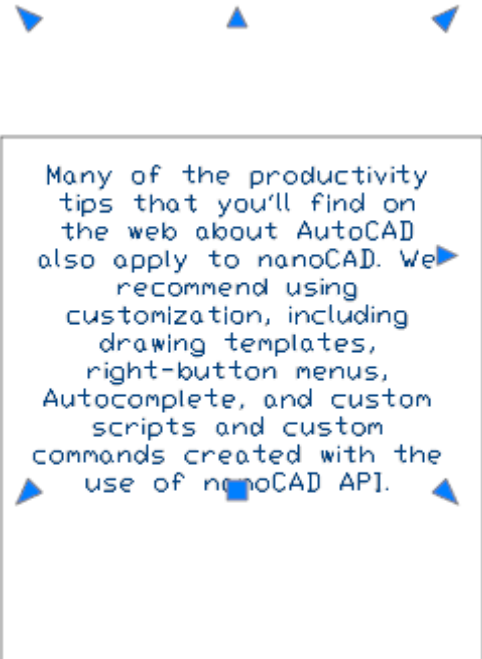
	 <p>Many of the productivity tips that you'll find on the web about AutoCAD also apply to nanoCAD. We recommend using customization, including drawing templates, right-button menus, Autocomplete, and custom scripts and custom commands created with the use of nanoCAD API.</p>
BC	<p>Justify text by the bottom margin and horizontal center.</p>  <p>Many of the productivity tips that you'll find on the web about AutoCAD also apply to nanoCAD. We recommend using customization, including drawing templates, right-button menus, Autocomplete, and custom scripts and custom commands created with the use of nanoCAD API.</p>
BR	<p>Justify text by the bottom and right margins.</p>



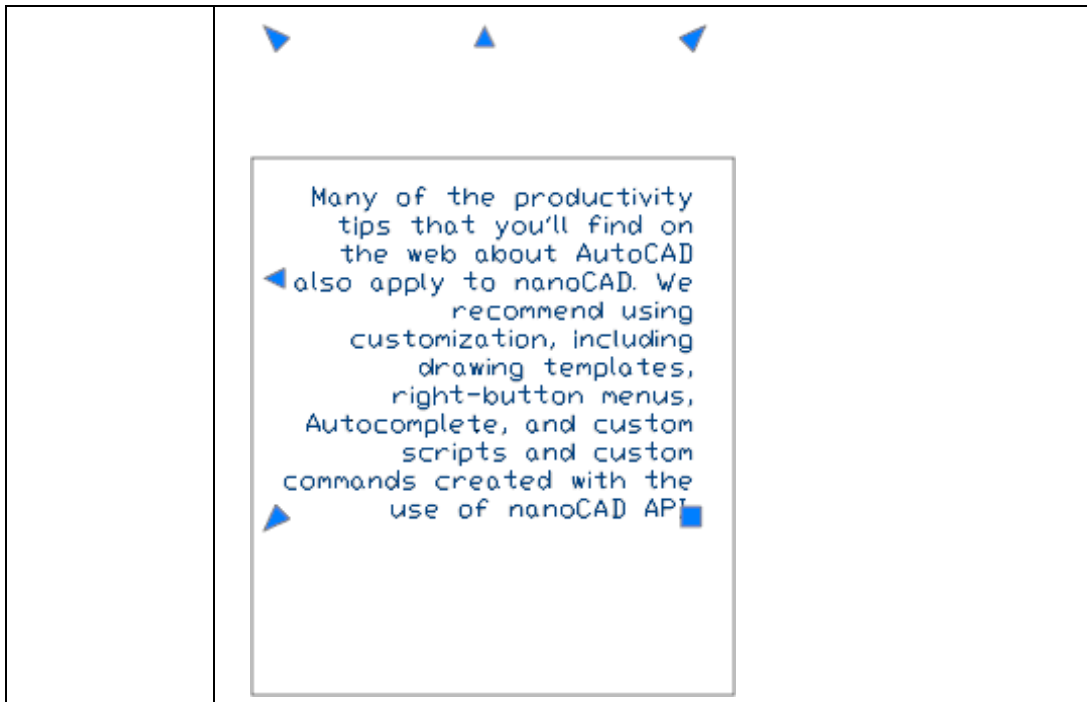

## Text Fit



Ribbon: **Annotate – Text** >  **Text Fit**



Menu: **Modify – Advanced Tools** >  **Text Fit**



Command line: **TEXTFIT**

This command allows you to stretch or shrink single-line text and move it.

1. Run command.
2. Select text. The first point (bottom left) is selected by default.
3. Specify the second point. Text will be inscribed between two points.

### Command options:

**Start Point** Specify new start point.

## Explode Text



Ribbon: **Annotate – Text** >  **Explode Text**



Menu: **Modify – Additional tools** >  **Explode text**



Command line: **EXPLODETEXT, TXTEXP**

You can explode text, to convert it into individual elements – solids (for TrueType texts if TEXTFILL=1 or Text=Filled in command options), polylines (for TrueType texts if TEXTFILL=0 or Text=Boundary in command options) or lines and polylines for SHX fonts. During the command, you can set different exploding options.

If you start Explode command with preselected texts – command will process with previous (or default) settings.

### Options:

? Additional options for object selection.

Settings Text explode settings:  
[Autoselect/Source/Properties/Text/Exit]

### Settings:

Autoselect Select created objects after explode:  
Yes - Select created objects after explode.  
No - Do not select created objects after explode.  
Exit - Return to Settings.

Source Keep or Erase source text:  
Erase - Erase source texts.  
Keep - Keep source texts.  
Exit - Return to Settings.

Properties Specify object properties source:  
Original - Keep original text properties.  
Current - Use current drawing settings.  
Exit - Return to Settings.

Text Fill settings for TrueType texts:  
Boundary - Create closed polylines.  
Filled - Create solids.  
textFill - As displayed, if TEXTFILL=1 – create solids, if TEXTFILL=0 create polylines.  
Exit - Return to Settings.

Exit Return to object selection.

### Command prompts:

Select text object for explode or [?/Settings]:

Choose Settings.

Settings

Specify desired settings. Then choose Exit or press **ENTER**.

Command settings

[Autoselect/Source/Properties/Text/Exit] <Exit>

Select text object for explode or [?/Settings]:

Select text objects for explode, then press **ENTER**.

## Change Text Case



Ribbon: **Annotate – Text** > **Tt** **Change text case**



Menu: **Modify – Advanced Tools** > **Tt** **Change Text Case**



Command line: **TCASE**

The command for editing case of words, sentences and paragraphs of the selected text.

1. Select a part of text.

2. Start **Change Text Case** command.
3. Choose desired parameter in the dialog that appears and click **OK**.

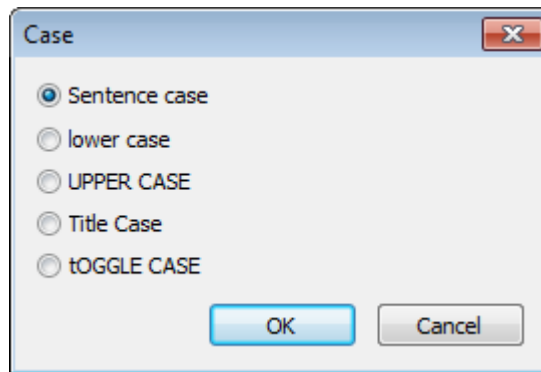

### Options:

<b>Sentence case</b>	Capitalizes the first letter of sentence and make other letters lowercase.
<b>lower case</b>	Makes all letters lowercase.
<b>UPPER CASE</b>	Capitalizes all letters.
<b>Title Case</b>	Capitalizes the first letter of each word, leaving the remaining letters in lowercase.
<b>tOGGLE CASE</b>	Changes case of each letter (For example: <i>CHaNGE</i> to <i>ChaNGe</i> ).

## Quick Text Mode



Ribbon: **Annotate – Text** >  **Contour text**



Menu: **View – Display** >  **Quick text**



Command line: **QTEXT**

The **Quick Text mode** hides the contents of text objects on the screen and print. Only bound rectangles instead of text objects or attributes are displayed on screen and print. Redrawing and regeneration of drawings containing a large number of text objects is faster when the **Quick Text mode** is on.

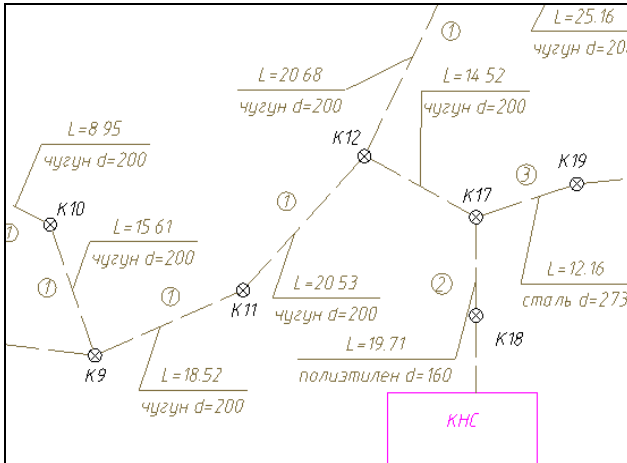



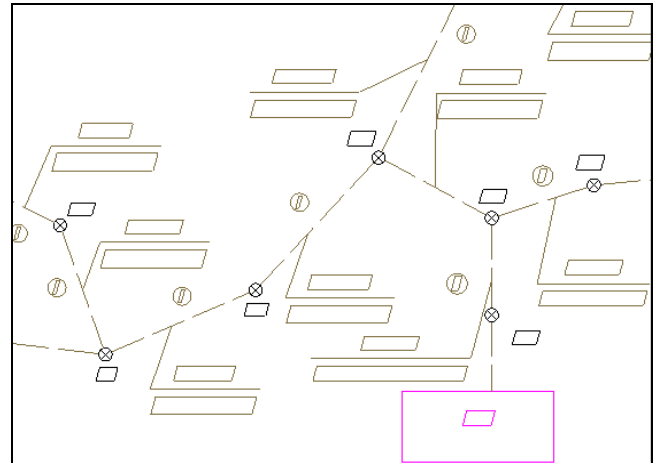









**Qtext mode is disabled**



**Qtext mode is enabled**

**NOTE:** The **Qtext** mode replaces all texts of the drawing by bounding boxes. At the same time, there is a possibility to replace with boundaries only the text, the size of which on the screen does not exceed a predetermined number of pixels. To do this, use the option **System settings – Rendering optimization – Simplify text less than <...> pixels** in the **Options** dialog box.

## Fields

-  Ribbon: **Insert – Data >**  **Field**
-  Menu: **Insert –**  **Field...**
-  Text format dialog: 
-  Context menu of Text and Multiline text: **Insert field**
-  Attribute definition dialog: 
-  Attribute redefinition dialog: 
-  Command line: **FIELD**

*Field* is special object that contains properties of other object (primitive, file, document, etc.). Field can be updated automatically as the field value changes. Field can be inserted to text, multiline text, block attribute.

**NOTE:** Field value displays with grey background, but background does not appear in print.

**NOTE:** A field without value display like (----).

**FIELD** command creates a multiline text object with only one field. Command opens **Field** dialog box. Set field type and format at the dialog. Then specify start point to insert the field. Field assigned the current text style.

Field can be inserted in text and multiline text through **Insert field...** in context menu and in attribute definition, in multiline text through the  button.

## “Field” Dialog Box

The **Field** dialog box opens whenever the user requests to insert a field. In this window, first of all, you need to specify the type of field to be inserted.

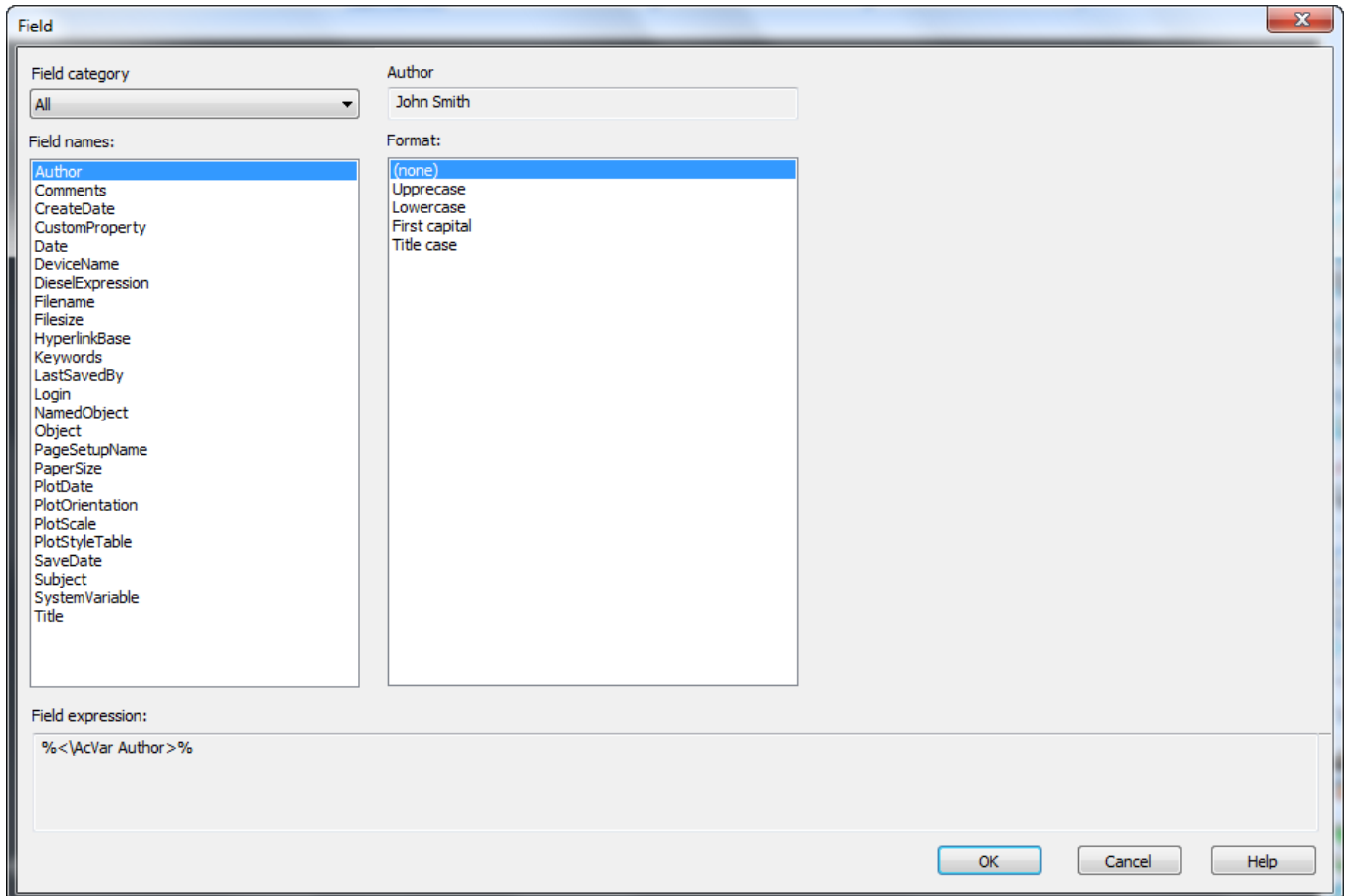

Fields vary in type. Field types are divided into categories. Available field types are shown in **Field names** list. **Field category** is filter for **Field names** list.

Often field shows the property of any text object. Available formats for text fields: **Uppercase**, **Lowercase**, **First capital**, **Title case**, and **none** if you don't need to change text format in field.

Field can show the numeric value of the property. For example, polyline area: select **Object** field name from **Objects** category.

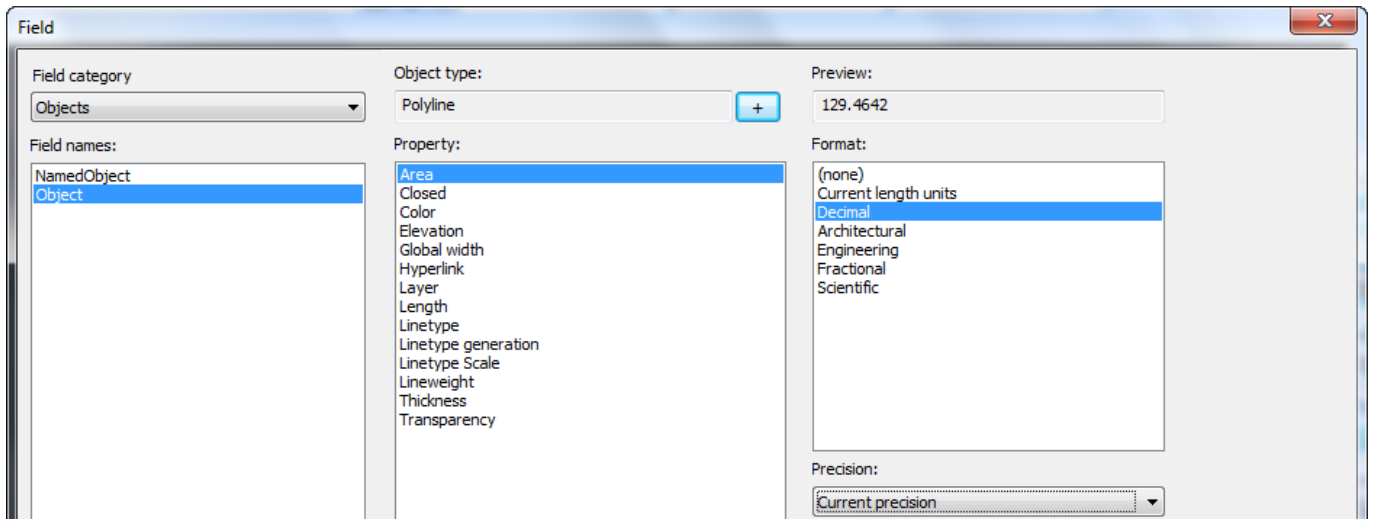

Then click  button and select needed polyline. Select **Area** property format and precision.

**Named object** field from **Objects** category displays names of blocks, views, dimension styles, layers, text styles, linetype styles.

**NOTE:** ##### symbols show fields of deleted objects.

Some fields can be context-dependent, their value depends on context location – bookmark sheet name, name of plotter for different sheets.

Contextual fields in blocks and external references are not updated when you insert them into a drawing, the field displays the last cached value. Therefore, if you want to use a contextual field in a block, you must insert the field as an attribute.

### *Fields Categories and Types*

All objects are divided into field categories: **Date & Time**, **Document**, **Plot**, **Other**, **Objects**. **All** category shows fields of all categories.

#### *Date & Time:*

<b>Create Date</b>	Date and time of the file creation.
<b>Date</b>	Current date and time.
<b>Plot Date</b>	Date and time of the last print.
<b>Save Date</b>	Date and time of the last save.

#### *Document:*

<b>Author</b>	Author from file properties.
<b>Comments</b>	Comments from file properties.
<b>CustomProperty</b>	Value of custom property from file properties.
<b>Filename</b>	The name of drawing file.
<b>Filesize</b>	The size of the last saved version of drawing.
<b>HyperlinkBase</b>	Hyperlink base from file properties.
<b>Keywords</b>	Keywords from file properties.

**LastSavedBy** Author of the last save.  
**Subject** Subject from file properties.  
**Title** Title from file properties.

**Plot:**

**DeviceName** Name of device for layout plot.  
**Login** Login of current user.  
**PageSetupName** Name of page setup for layout.  
**PaperSize** Paper format.  
**PlotDate** The date and time of the last plot.  
**PlotOrientation** Orientation of paper.  
**PlotScale** Plot scale for layout.  
**PlotStyleTable** The name of plot style table.

**Other:**

**DieselExpression** Value of Diesel expression.  
**SystemVariable** Value of system variable.

**Objects:**

**BlockPlaceholder** Block reference property. Only accessible in the block editor  
**NamedObject** Name of named object: layer, style, etc.  
**Object** Value of primitive property.  
**Formula** Math expression, may contain other fields.

*Options for fields in this category:*

**Display value for block reference** – the checkbox is displayed only for object properties fields that are located inside the block. For example, when editing a field inside a block attribute definition.

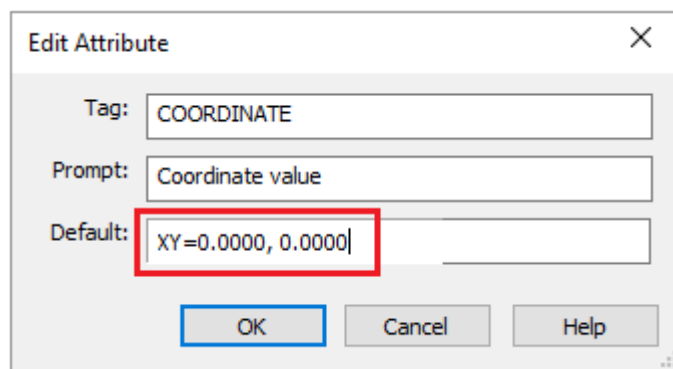

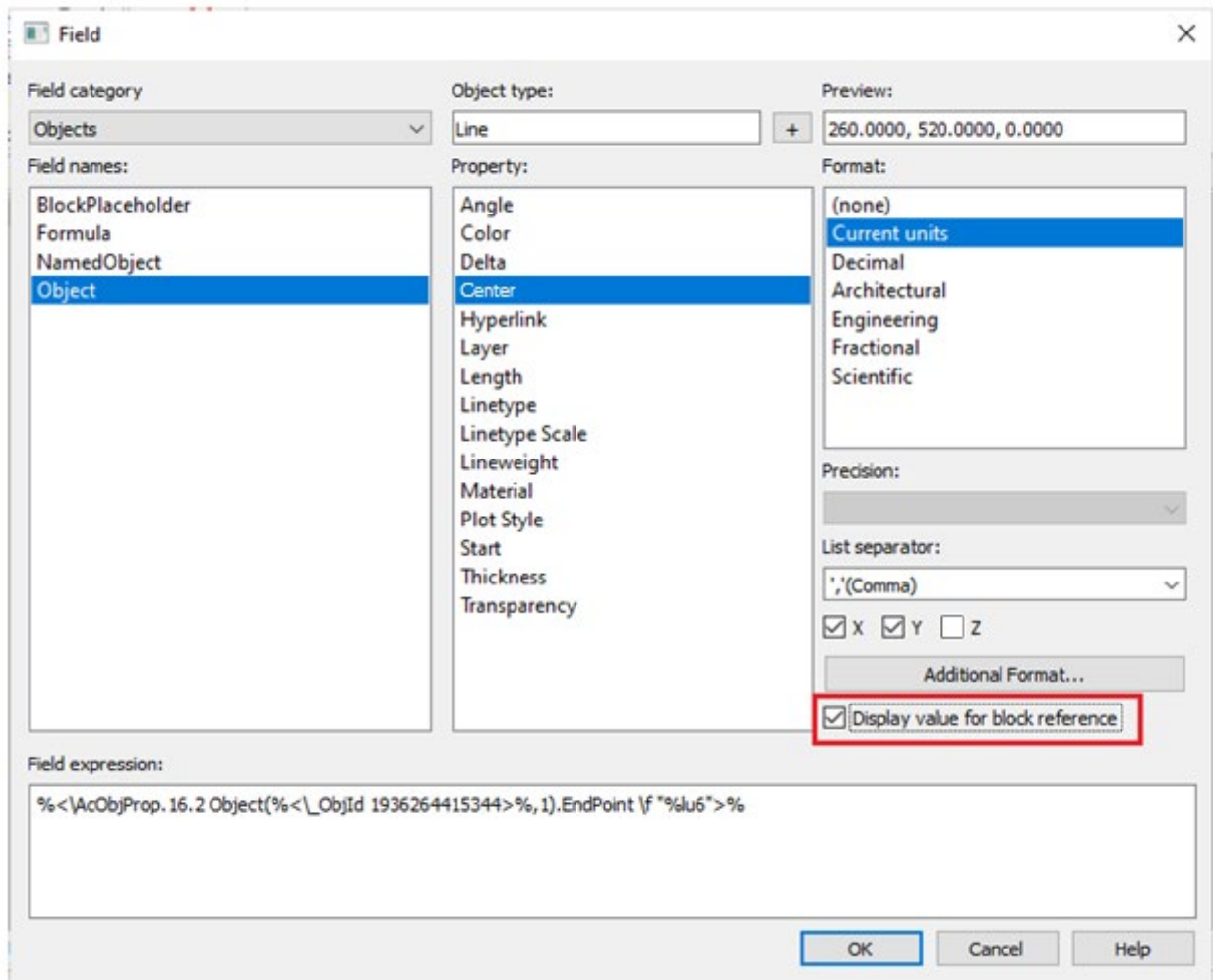

The parameter obliges the property to calculate its value relative to the size and orientation of the block reference in the drawing, and not relative to the internal block description space. So, for example, the coordinates of the center of the object included in the block will be calculated relative to the drawing coordinate system, and not relative to the coordinates of the block definition.

### SheetSet Category:

<b>CurrentSheetCustom</b>	Value of additional property of the current sheet
<b>CurrentSheetDescription</b>	<b>Description</b> in the <b>Sheet</b> group of properties
<b>CurrentSheetIssuePurpose</b>	<b>Purpose</b> in the Sheet properties
<b>CurrentSheetNumber</b>	<b>Number</b> in the Sheet properties
<b>CurrentSheetNumberAndTitle</b>	Combination of Number and Title of sheet
<b>CurrentSheetRevisionDate</b>	<b>Revision date</b> in the sheet properties
<b>CurrentSheetRevisionNumber</b>	<b>Revision number</b> in the sheet properties
<b>CurrentSheetSet</b>	<b>Name</b> in the <b>Sheet Set Properties</b>
<b>CurrentSheetSetCategory</b>	<b>Category</b> in the sheet properties
<b>CurrentSheetSetCustom</b>	Value of a <b>Sheet Set Custom Property</b>
<b>CurrentSheetSetCustomerFullName</b>	<b>Customer full name</b> of the current sheet set



<b>CurrentSheetSetCustomerShortName</b>	<b>Customer short name</b> of the current sheet set
<b>CurrentSheetSetDescription</b>	<b>Description</b> in the <b>Sheet Set</b> properties group
<b>CurrentSheetSetObjectName</b>	<b>Object name</b> of the current sheet set
<b>CurrentSheetSetOrganizationName</b>	<b>Organization name</b> of sheet set
<b>CurrentSheetSetProjectMilestone</b>	<b>Project milestone</b> in the <b>Project Control</b> group
<b>CurrentSheetSetProjectName</b>	<b>Project name</b> in the <b>Project Control</b> group
<b>CurrentSheetSetProjectNumber</b>	<b>Project number</b> in the <b>Project Control</b> group
<b>CurrentSheetSetProjectPhase</b>	<b>Project phase</b> in the <b>Project Control</b> group
<b>CurrentSheetSetSheetsCount</b>	Number of sheets in the current sheet set
<b>CurrentSheetSetVolumeNumber</b>	<b>Volume number</b> of the current sheet set
<b>CurrentSheetSetYearOfManufacture</b>	<b>Year of manufacture</b> of sheet set
<b>CurrentSheetSubSet</b>	Subset name
<b>CurrentSheetTitle</b>	<b>Title</b> in the sheet properties
<b>CurrentSheetSetViewTitle</b>	Title of the sheet set view
<b>CurrentSubsetCustom</b>	Value of custom property of subset
<b>CurrentSubsetSheetsCount</b>	Number of sheets in the current subset
<b>CurrentSheetViewNumberAndTitle</b>	Combination of Number and Title of sheet view

## Update Field



Ribbon: **Insert – Data** >  **Update Fields**



Menu: **Tools** –  **Update fields**



Context menu of Text and Multiline text: **Update field**



Command line: **UPDATEFIELD**

Update field manually to see the latest value. Select needed objects and press **ENTER**, fields in selected objects will be updated.

Select field and open the context menu in Text or Multiline text, find there **Update field**. Field will display the current value.

FIELDEVAL system variable controls how fields are updated.

## Edit Field



Double-click the left mouse button on the field



Context menu of Text and Multiline text: **Update field**

When editing single-line or multi-line text, the **Edit Field** option will appear in the context menu if you select the field to edit or position the cursor directly in front of the field. Selecting this menu item will open the **Field** dialog box, where you can change the field parameters

**NOTE:** Attempt to edit field of unknown type, nanoCAD shows the message: **Unknown field.**

## Convert Field to Text



Context menu of Text and Multiline text: **Convert field to text**

Before using this context menu item, select the field in the open single-line or multi-line text editor or place the cursor directly in front of the field. After this, the **Convert field to text** item will appear in the menu, with which you can replace the field with text with the current field value

## Dimensioning

Dimensions display the geometrical attributes of the objects on the drawing, as well as the distances and angles between them. The dimensions are part and parcel of any drawing.

In general, dimensions can consist of the following items:

- *The dimension line* indicates the direction and extent of a dimension. For angular dimensions, the dimension line is an arc.
- *The extension line* is drawn from the measured object to the dimension line.
- *Arrows* are displayed at the ends of the dimension line. You can use different types of arrows, including tick marks and points.
- *The dimension text* displays the numerical value of the measured object. The text can also include prefixes and suffixes, for example, symbols of the radius, diameter, degree, etc., as well as tolerances.
- *The leader* is the line joining together the dimension text and the dimension line to which it belongs. Leaders can be created automatically (when the corresponding options are set), when the text size does not fit between the extension lines or when you manually drag the dimension text (with grips) to another place.

The four basic types of dimensioning are:

- *Linear dimensions* display the distance between the specified points. This type includes the following dimensions:
  - *horizontal,*
  - *vertical,*
  - *aligned,*
  - *ordinate,*
  - *group dimension,*
  - *base dimension* and
  - *dimensions chain.*
- *Radial dimensions* indicate the radii and diameters of arcs and circles. These include:
  - *diameter,*

- *radius*,
- *big radius*.
- *Angular dimensions* are used to indicate the angles between two segments or three points.
- *Arc dimensions* display the length of an arc or an arc segment of a polyline.

Dimensions can be *associative*, *non-associative* or *exploded*. Associative dimensions adjust to changes in the geometric objects that they measure.

- *Associative dimensions*. Automatically adjust their locations, orientations and measurement values when the geometric objects associated with them are modified.
- *Non-associative dimensions*. Selected and modified with the geometry they measure. Non-associative dimensions do not change when the geometric objects they measure are modified.
- *Exploded dimensions*. Contain a collection of separate objects: lines, arrows, arcs and text, rather than a single dimension object. Exploded dimensions do not change when the geometric objects they measure are modified.

To manage the associativity of dimensions, use the **Set associativity during insertion of objects** option of the **Settings nanoCAD Int** dialog box on the **Main options** tab of the **Edit** section (the **Tools** menu – **Advanced Settings**). The option has two values: **Yes** – for associative dimensions and **No** – for non-associative dimensions. To get the exploded dimensions, you should use the **Explode** command from the **Modify** menu.

**NOTE!** In nanoCAD, the system variable **DIMASSOC** does not affect to the associativity of dimensions.

**NOTE:** It is not recommended to disable the associative dimensioning mode which is used by default or to explode the associative dimensions without a strong reason.

In nanoCAD, the dimensioning commands are available on the **Annotate** tab of the ribbon, the **Dimensions** main menu and the **Utilities** toolbar:

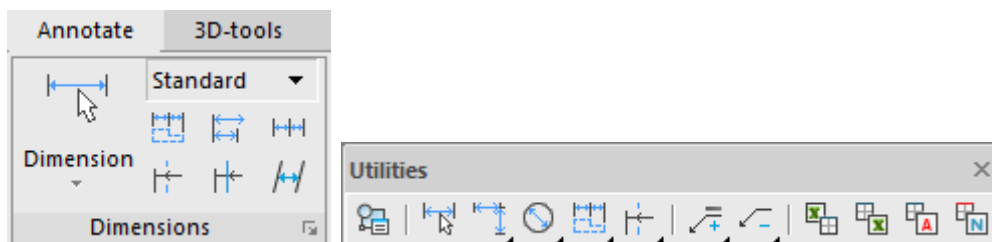

If necessary, you can use the **Dimensions** toolbar:



## Some Features of nanoCAD's Dimensioning

### Set the Scale for Dimensions

You can specify the size of dimensions in your drawing. Set the scale value using the **Scale** icon in the status line. *Dimension scale* affects the size of the dimension geometry relative to the objects in the drawing. At dimensioning, all size elements (height of the dimension text, size of the arrows etc.) are automatically scaled corresponding to the current *dimension scale*.

The **Dimension scale** is useful to dimension fragments drawn in the model space at the 1:1 scale. Their scale will change at arrangement on the worksheet.

For example, two views are drawn in the model space at the 1:1 scale. The first view will be placed on the layout at 1:1, the second view (based on its actual size) at 1:10. For dimensioning in the model space, you must specify the dimension scale as 1:1 for the first view and 1:10 for the second view. All elements of dimensioning of the first view will have values determined by the dimension style (for example, the height of the dimension text – 2.5 mm, the length of the arrows – 2.5 mm, etc.). The value of the second view dimensions will be automatically increased by 10 times (the height of the dimension text in the model space will be 25 mm, the length of the arrow – 25 mm), so that the dimensions are displayed correctly (the height of the dimension text – 2.5 mm, the length of the arrows – 2.5 mm, etc.) when this view is inserted on the layout.

When you change the *dimension scale*, the dimensions are not recalculated automatically.

To change any size of dimension scale, it is necessary to select it and select the required scale in the **Measurement scale** menu.

To set drawn dimensions to the current dimension scale, it is necessary to select the **Set to selection** command in **Measurement scale** menu and select the required dimensions on the drawing.

For more information on using scale, see «Symbol scale and measurement scale» section.

## Dimensioning with a Single Command



Ribbon: **Home, Annotate – Dimensions >**  **Dimension**



Menu: **Dimensions –**  **Auto**



Toolbar: **Utilities –** 



Command line: **MDIM**

1. You can set all dimensions in nanoCAD using a single command – **Auto** (the **Dimensions** menu) or **Dimensions** (on the **Utilities** and the **Dimensions** toolbars).

It is recommended to turn on the snap mode to maximise the facilities for dimensioning with a single command; set the required type of snap as a permanent snap. Switch on the **To turn the object snap “Nearest” on automatically during an insert of objects** option in the **nanoCAD – Options** dialog box on the **Main** tab of the **Edit** section (the Tools menu – Settings parameters).

2. Start the **Auto** command and select any dimensions from the context menu by right clicking:

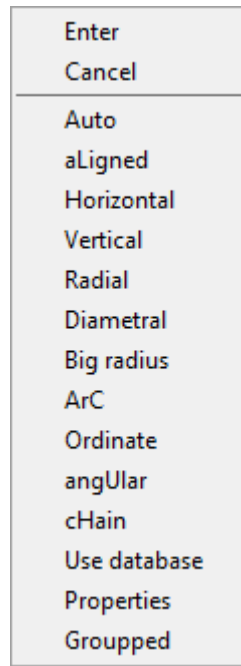

or by selecting the appropriate option in the command line:





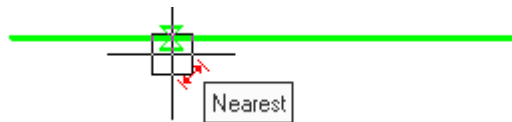

Insert dimension or [Auto/aLigned/Horizontal/Vertical/Radial/Diametral/Big radius/ArC/Ordinate/angUlar/cHain/Use database/Properties/Grouped]:

3. You can also set dimensions on the drawing directly after starting the **Auto** command.

When you move the cursor over any graphic entity (segment, segment of polyline, arc or circle) it will be highlighted automatically:



When the graphic entities are highlighted, nanoCAD displays the secondary symbols near the cursor that serve as prompts for the user. The secondary symbols indicate what dimension will be drawn if you left click on the graphic entity:

-  - Aligned dimension.
-  - Horizontal dimension.
-  - Vertical dimension.
-  - Diameter dimension.
-  - Radius dimension.
-  - Angle dimension.
-  - Base dimension.

This method is used for dimensioning relating to a graphic primitive.

4. To quickly draw the dimensions that relate to a graphic primitive, you can turn off the object snap mode.
5. When you move the cursor along the highlighted primitive, the corresponding snap markers are displayed at its characteristic points. You can use it to specify the initial points of the extension lines:

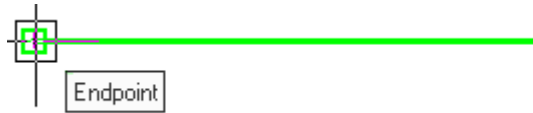

This method is used for dimensioning the elements of a drawing consisting of several graphic primitives.

6. nanoCAD allows you to place the dimensions at given distances from each other, not only in base dimensions, but also at linear dimensioning. The distance by which the new dimension should be spaced from the existing one, is specified by a *base-line spacing* option in the **Modify dimension style** dialog box on the **Lines** tab.

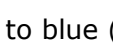
To do this, it is necessary to specify the position of the dimension line and slowly move the cursor from the existing dimension line. When you draw near a specified distance, the new dimension line will be "attracted" to the required position. The color of the secondary character displayed near the cursor changes from red (  ) to blue (  ):

Dimension line is not at the specified distance

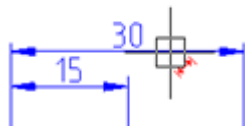

Dimension line is at the specified distance

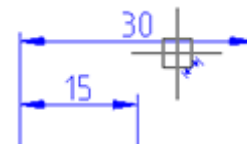

7. At dimensioning, you can set the extension line oblique by holding the **CTRL** key and moving the cursor in the desired direction.
8. To change the position of the dimension text, hold the **SHIFT** key and move the cursor to the first or second extension line (by default, the dimension text is located in the center of the dimension line).
9. During dimensioning, you can use the **Edit dimension** dialog box to specify the required properties and options for the executable dimension. To do this, it is necessary to select the **Properties** option in the command line or context menu. The dimensioning command is not interrupted.
10. To finish dimensioning, press **ESC** or select **Cancel** from the context menu.
11. You can dimension chamfers and fillets during their creation. Turn on the *Measure chamfer* or *Measure fillet* mode in the **Chamfer** or **Fillet** dialog box.

## Linear Dimensions

### Horizontal, Vertical and Aligned Dimensioning

In the following examples, horizontal, vertical and aligned dimensions are created by using the **Auto** command.



Ribbon: **Home, Annotate - Dimensions** >  **Linear**



Menu: **Dimensions** -  **Auto**



Toolbar: **Utilities** - 



Command line: **DIMLINEAR**

Setting linear dimensions with a horizontal, vertical or rotated dimension line.

1. Specify the starting points of the first and second leaders or press **ENTER** to select an object.
2. Select the dimensioning option in the command line or context menu.
3. Specify the position of the dimension line.





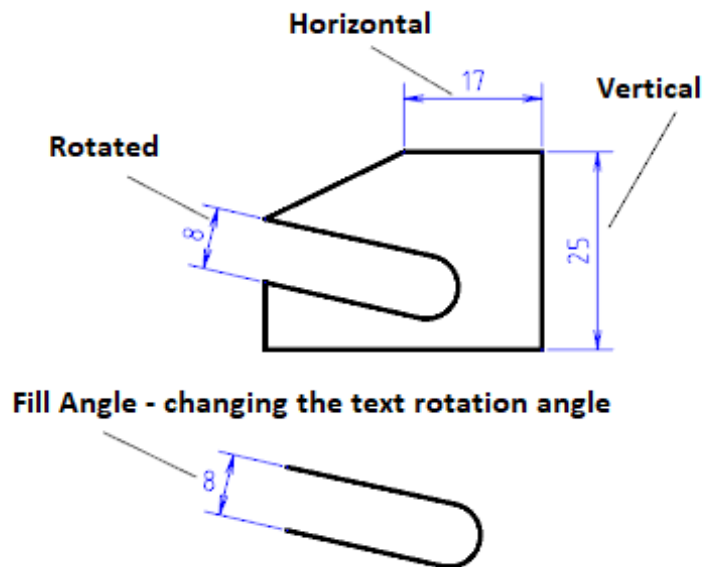

**Command options:**

- Mtext Enters multiline text. The **Text Format** bar opens.
- Text Enters or changes dimension text in the command line.
- Horizontal Sets a horizontal dimension.
- Vertical Sets a vertical dimension.
- Rotated Sets the dimension at a certain angle.
  - Specify the rotation angle of the dimension line on the screen or in the command line.
- Fill Angle Changes the rotation angle of the dimension text.
  - Specify the rotation angle of the dimension text on the screen or in the command line.



## Setting horizontal, vertical and parallel dimensions

In the examples below the **Auto** command is used for setting horizontal, vertical and parallel dimensions.

-  Ribbon: **Home, Annotation – Dimensions** >  **Auto**
-  Menu: **Dimensions** –  **Auto**
-  Toolbar: **Utilities, Dimensions** – 
-  Command line: **MDIM**

To dimension you can use also the **Horizontal**, **Vertical** and **Aligned dimension** commands.

**To specify the horizontal dimension of the line:**

1. Start the **Auto** command.
2. Place the cursor over the line to show its dynamic highlighting and display the character . Left click to confirm the dimensioning:

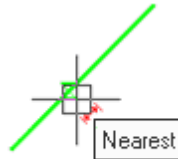

3. Move the cursor down to change the character to :

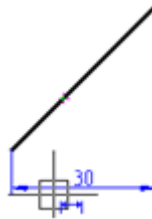



4. Left click to set the position of the dimension line:

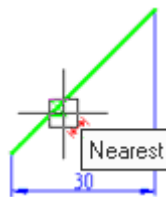

**To specify the vertical dimension of the line:**

1. Place the cursor over the line to show its dynamic highlighting and display the character . Left click to confirm the dimensioning:



2. Move the cursor to the right to change the character to :

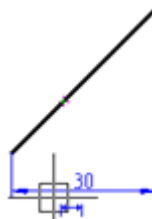

3. Left click to set the position of the dimension line:





**To specify the aligned dimension of the line:**

1. Place the cursor over the line to show its dynamic highlighting and display the character . Left click to confirm the dimensioning:

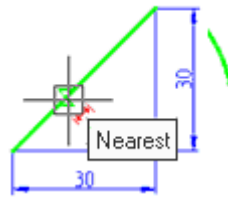

2. Move the cursor to the left to change the character to :

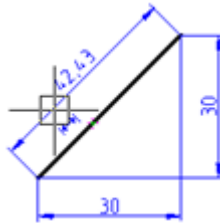

3. Left click to set the position of the dimension line:

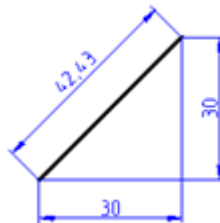

**For dimensioning the arc length using characteristic points:**

1. Start the **Auto** command.
2. Place the cursor over the arc to show its dynamic highlighting:

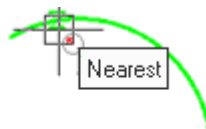

3. Move the cursor near to the endpoint of the arc. When the snap marker appears, left click to choose the endpoint of the first extension line of the dimension:

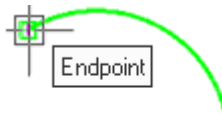

4. Move the cursor to the other endpoint of the arc and left click to choose the endpoint of the second extension line of the dimension:

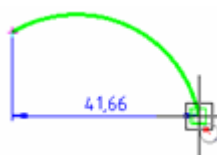

5. Move the cursor to the middle of the arc to display the character :

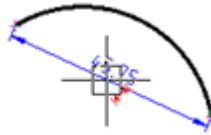

6. Move the cursor down and to the left to change the character to  :

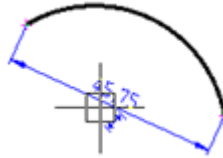

7. Left click to set the position of the dimension line:

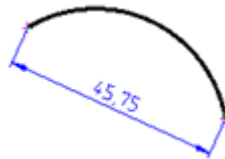

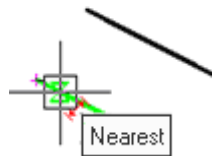

***For dimensioning between two parallel line segments:***

1. Start the **Auto** command.
2. Select the lower line segment by highlighting it and left click:

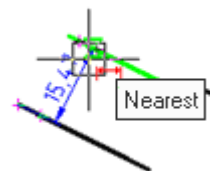

3. Select the top line segment by highlighting it and left click when the horizontal character appears:



4. Move the cursor up and to the left to change the character to  :

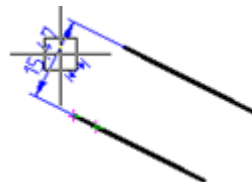

5. Left click to set the position of the dimension line:

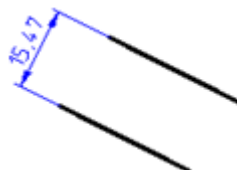

***To draw the dimension from a point to a line segment:***

1. Start the **Auto** command.
2. Select the lower line segment by highlighting it and left click:

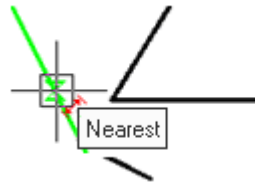

3. Select the endpoint of the second line segment using the snap:

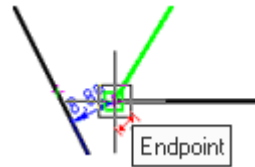

4. Move the cursor up and to the left:

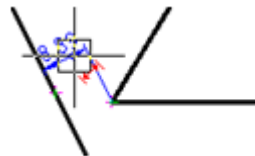

5. Left click to set the position of the dimension line:



## Ordinate Dimensioning



Ribbon: **Home, Annotate – Dimensions** >  **Ordinate**



Menu: **Dimensions** –  **Ordinate**



Toolbar: **Utilities** – 



Command line: **MDIMORD**

**To specify the chain of linear ordinate dimensions:**

1. Start the **Auto** command.
2. Select the Ordinate option in the command line or context menu.
3. Specify the first point of the first dimension:



4. Specify the second point of the first dimension:

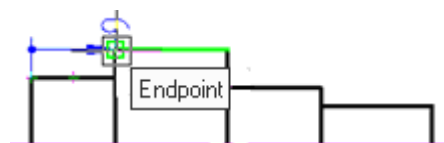

5. Specify the dimension line location:

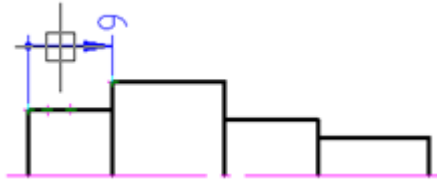

6. Select the **Base** option in the command line or context menu and specify the endpoint of the second ordinate dimension:

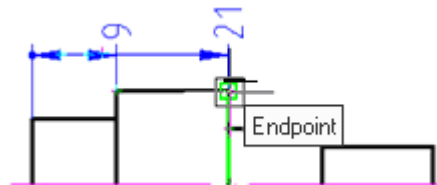

7. Specify all the endpoints of the other ordinate dimensions:

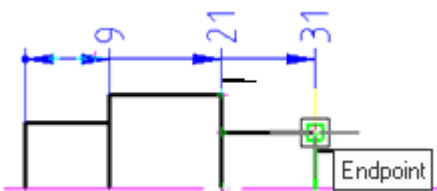

8. Press **ENTER** to finish the command:

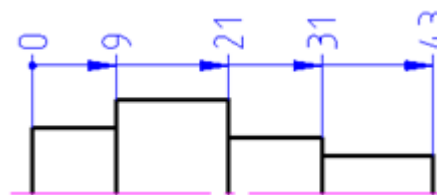

**To specify the chain of angular ordinate dimensions:**

1. Start the **Auto** command.
2. Select the **angUlar** option in the command line or context menu
3. Specify the first point of the angular dimension (vertex of angle):

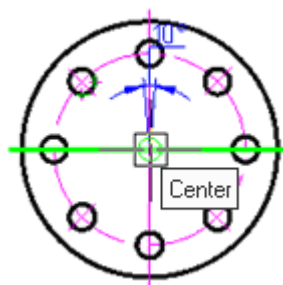

4. Specify the second point of the angular dimension:

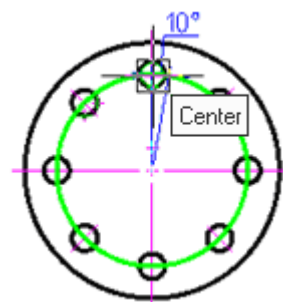

5. Specify the third point of the angular dimension:

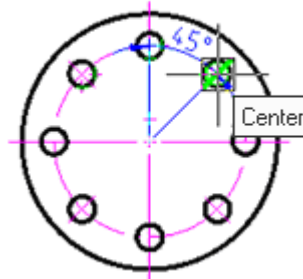

6. Select the **Ordinate** option in the context menu and specify the dimension line location:

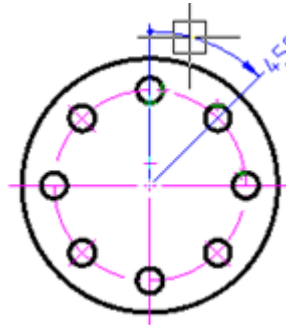

7. Select the **Chain** option in the command line or context menu and specify the endpoint of the second dimension:

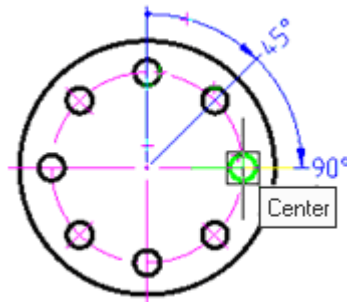

8. Specify the endpoint of the third dimension:

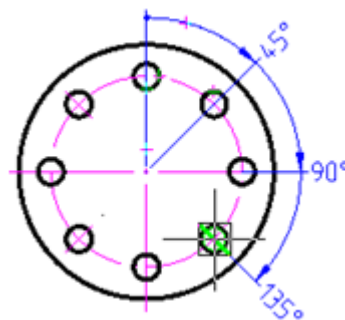

9. Specify the endpoint of the last dimension:

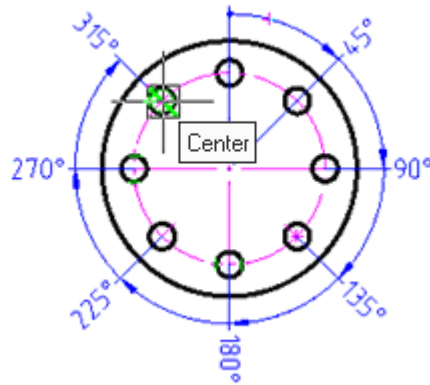

10. Press **ENTER** to finish the command:

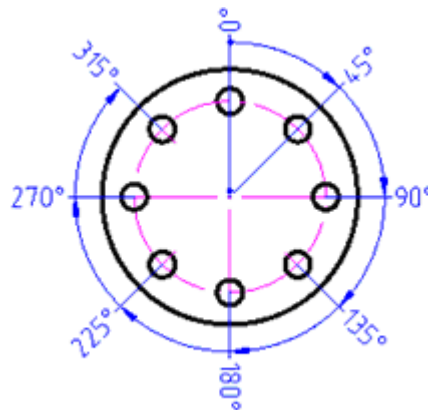

## Group Dimensioning

Ribbon: **Home, Annotate - Dimensions** >  **Group Dimension**

 Menu: **Dimensions** -  **Group dimension**

 Toolbar: **Utilities** - 

 Command line: **QDIM, DIMGROUP**

The **Group dimension** command is particularly useful for creating a series of vertical or horizontal dimensions.

### To specify the group dimensions:

1. Start the **Auto** command.
2. Select the Grouped option in the command line or context menu.
3. Select the objects you want to dimension:



4. Press **ENTER** to end the selection of objects:

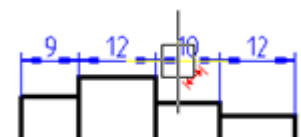

Depending on the direction of the cursor movement (vertical or horizontal), the chain of vertical or horizontal dimensions will be dynamically displayed.

5. Move the cursor to change the character from red to blue  :

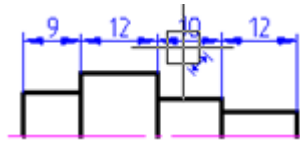

6. Left click to specify the location of the dimension lines:

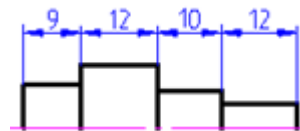

When dimensioning the objects that have a small length

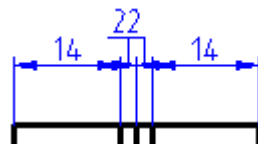



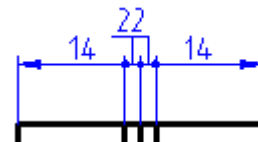
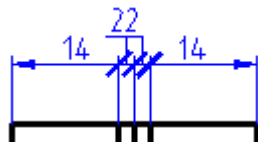

The crossed arrows are automatically replaced by notches or points:

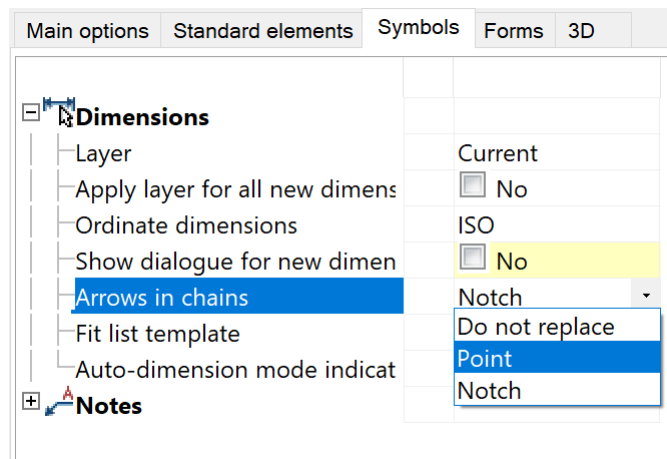

The setting for replacement of intersecting arrows is performed in the **nanoCAD – Options** dialog box (The **Tools** menu - **Settings Parameters**):



## Base Dimensioning

-  Ribbon: **Home, Annotate - Dimensions** >  **Baseline Dimension**
-  Menu: **Dimensions** –  **Base dimension**
-  Toolbar: **Utilities** – 
-  Command line: **DBA, DIMBASELINE**

*Base dimensions* are a sequence of dimensions measured from a reference point.

A *base dimension* creates a linear, angular or ordinate dimension from the baseline of the previous or selected dimension.

**To draw the base dimensions:**

1. Start the **Auto** command.
2. Select the **Base** option in the command line or context menu
3. Select the extension line of the previous dimension as a base:



4. Specify the endpoint of the first dimension:

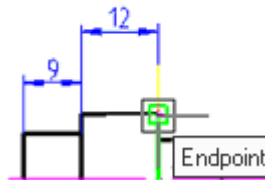

5. Specify the endpoints for all the other dimensions and press **ENTER** to finish the command:

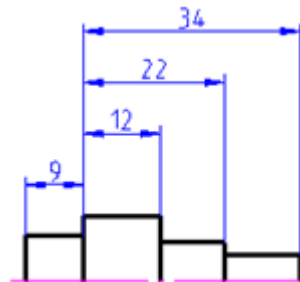

The default spacing between the baseline dimensions can be set from the **Modify dimension Style, Lines** tab, **Baseline Spacing**.

## Chain Dimensioning



Ribbon: **Home, Annotate - Dimensions** >  **Continue Dimension**



Menu: **Dimensions** -  **Dimensions chain**



Toolbar: **Utilities** - 



Command line: **DCO, DIMCONTINUE, CHAINCONT**

The *dimensions chain* creates a dimension that starts from an extension line of a previously created dimension.

The *dimensions chain* can be a linear, angular or ordinate.

To draw the *dimensions chain*, the object must have at least one linear, angular or ordinate dimension.

**To draw the dimensions chain:**



1. Start the **Auto** command.
2. Select the **CHain** option in the command line or context menu.
3. Select the previously created dimension as the base:

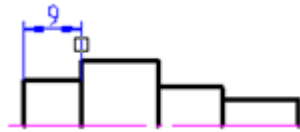

4. Specify the endpoint of the first dimension:

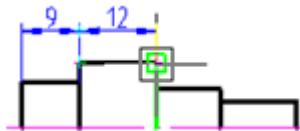

5. Specify the endpoints for all the other dimensions and press **ENTER** to finish the command:



## Radial Dimensions

### Diameter Dimensioning



Ribbon: **Home, Annotate - Dimensions** >  **Diameter**



Menu: **Dimensions** -  **Diameter dimension**



Toolbar: **Utilities** - 



Command line: **MDIMDIA**

#### For dimensioning the diameter of a circle:

1. Start the **Auto** command.
2. Place the cursor over the circle to show its dynamic highlighting and display the character . Left click to confirm the dimensioning:

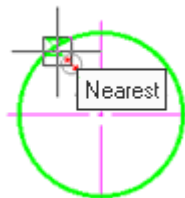

3. Choose the location of the dimension:

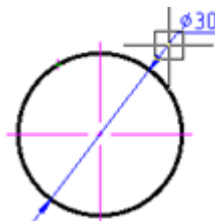

- Left click to fix the chosen location of the dimension:

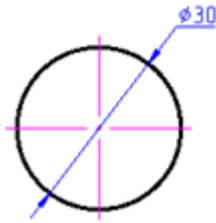

**For dimensioning the diameter of a circle using characteristic points:**

- Turn on the **Quadrant** snap.
- Start the **Auto** command.
- Place the cursor over the circle to show its dynamic highlighting and display the character . Left click to confirm the dimensioning:

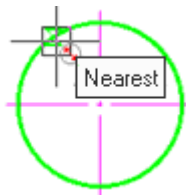

- Move the cursor to the first characteristic point of the circle and left click to specify the endpoint of the first extension line of the dimension.

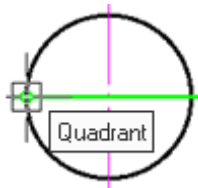

- Move the cursor to the second characteristic point of the circle and left click to specify the endpoint of the second extension line of the dimension.

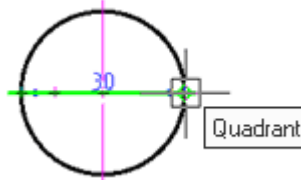

- Move the cursor up to display the character  :

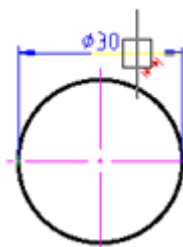

- Move the cursor up to change the character from red to blue:



8. Left click to set the location of the dimension line:

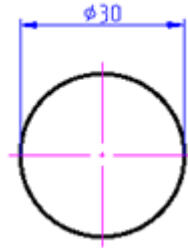

## Radial Dimensioning



Ribbon: **Home, Annotate - Dimensions** >  **Radius**



Menu: **Dimensions** -  **Radius dimension**



Toolbar: **Utilities** - 



Command line: **MDIMRAD**

### To draw the radius of a circle:

1. Start the **Auto** command.
2. Select the Radial option in the command line or context menu.
3. Place the cursor over the circle to show its dynamic highlighting. Left click to confirm the dimensioning:

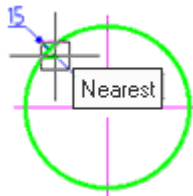

4. Choose the location of the dimension:

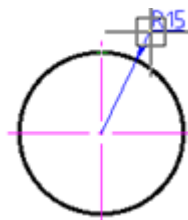

5. Left click to fix the chosen location of the dimension:

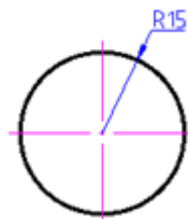

### To draw the arc radius:

1. Start the **Auto** command.
2. Place the cursor over the arc to show its dynamic highlighting and display the character . Left click to confirm the dimensioning:

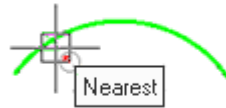

3. Choose the location of the dimension:







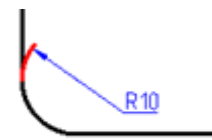
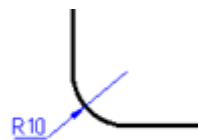
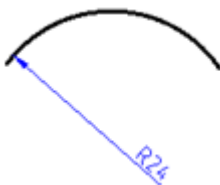

4. Left click to fix the chosen location of the dimension:



Options for dimensioning the arc radius:



## Big Radius Dimensioning

-  Ribbon: **Home, Annotate - Dimensions** >  **Jagged**
-  Menu: **Dimensions** -  **Big radius**
-  Toolbar: **Utilities** - 
-  Command line: **DIMJOGGED, DJO**

The *big radius* command creates jogged dimensions for circles and arcs.

### To draw the big radius:

1. Start the **Auto** command.
2. Select the **BigRadius** option in the command line or context menu.
3. Place the cursor over the arc to show its dynamic highlighting. Left click to confirm the dimensioning:

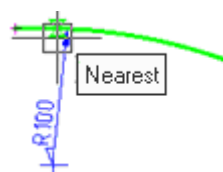

4. Choose the location of the dimension:

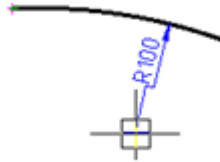

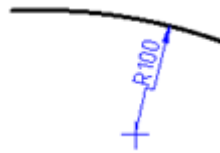

5. Left click to fix the chosen location of the dimension:



## Angular Dimensions

 Ribbon: **Home, Annotate - Dimensions** >  **Angular**

 Menu: **Dimensions** -  **Angle dimension**

 Toolbar: **Utilities** - 

 Command line: **MDIMANG**

**To draw the angle between two segments:**

1. Start the **Auto** command.
2. Place the cursor over one of the segments to show its dynamic highlighting and display the character . Left click to confirm the dimensioning:

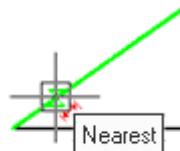

3. Place the cursor over the second segment to show its dynamic highlighting and display the character . Left click to confirm the dimensioning:

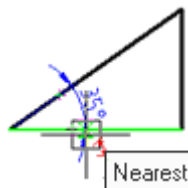

4. Choose the location of the dimension:

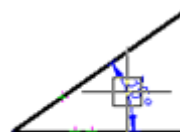

5. Left click to set the location of the dimension line:

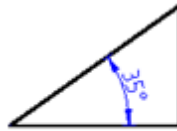

**For dimensioning the angular dimension using characteristic points:**

1. Start the **Auto** command.
2. Select the anGular option in the command line or context menu.
3. Specify the first point of the angular dimension (vertex of angle):

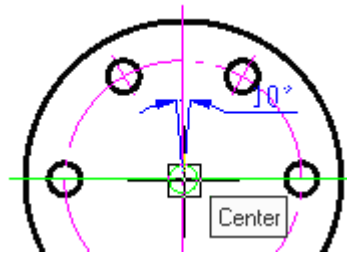

4. Specify the second point of the angular dimension:

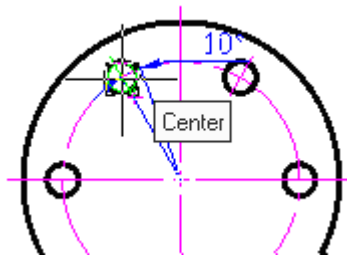

5. Specify the third point of the angular dimension:

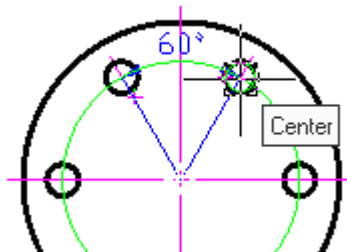



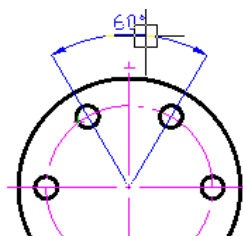

6. Specify the location of the dimension line:

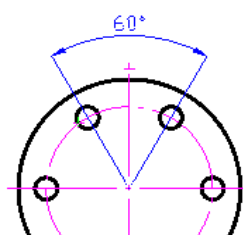







7. Press **ENTER** to finish the command



## Angle Ordinate Dimension

-  Ribbon: **Home, Annotate - Dimensions** >  **Angle ordinate**
-  Menu: **Dimensions** –  **Angle ordinate dimension**
-  Command line: **DIMAORD**

## Arc Length

-  Ribbon: **Home, Annotate - Dimensions** >  **Arc Length**
-  Menu: **Dimensions** –  **Arc**
-  Toolbar: **Utilities** – 
-  Command line: **MDIMARC**

This command creates an arc length dimension. Arc length dimensions measure the distance along an arc or polyline arc segment.

To differentiate between the arc dimensions and the linear or angular dimensions, the arc symbol is displayed above the dimension text by default.

### For dimensioning the arc length dimension:

1. Start the **Auto** command.
2. Select the **arc** option in the command line or context menu.
3. Place the cursor over the arc to show its dynamic highlighting. Left click to confirm the dimensioning:

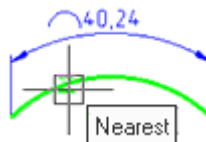

4. Choose the location of the dimension:

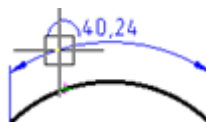

5. Left click to fix the chosen location of the dimension:

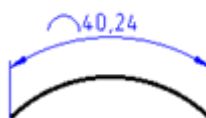

### For dimensioning the length of Circle part:





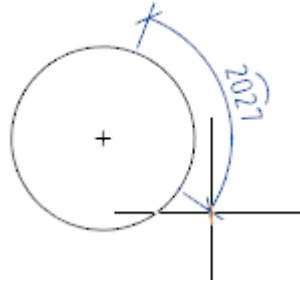

1. Start the **Auto** command.
2. Select the **arc** option in the context menu.
3. Place the cursor over the arc to show its dynamic highlighting. Click at the start point of dimensioning part of circle.

4. Place the cursor over the arc to show its dynamic highlighting. Click at the end point of dimensioning part of circle.
5. Choose the location of the dimension:



6. Click to fix chosen location of the dimension.

## Offset Dimension

-  Ribbon: **Home, Annotation – Dimensions >**  **Offset Dimension**
-  Menu: **Dimensions –**  **Offset Dimension**
-  Toolbar: **Utilities, Dimensions –** 
-  Command line: **DIMOFFSET**

The command allows you to construct a dimension similar to the outline of the selected object. Offset dimension is indicated by an arc over the value.

### To set an angular offset dimension:

Run the **Offset Dimension** command.

Specify the object from which the dimension will be created. The selected object can be: segment, arc, spline, polyline, circle or ellipse.

Specify the first insertion point (the starting point of the dimension), then specify the second insertion point (the end point of the dimension).

Place a dimension leader in the drawing.

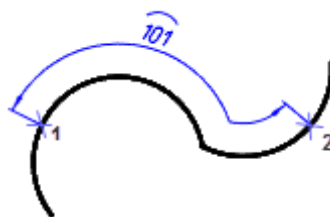

To automatically set dimensions at the end points along the entire length of the object, press the **SPACEBAR** key or RMB (does not work for closed objects).

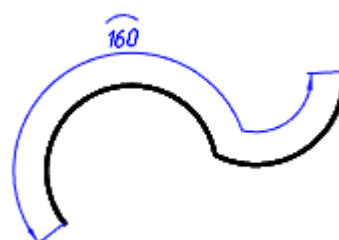

The command will continue to work in a cyclic mode. To exit the cyclic mode, press the **Esc** key.



## Dimensions Editing

The **Edit dimension** dialog box (if **Yes** is chosen for the **Dimensions** option of the **Settings nanoCAD Int** dialog box on the **Main options** tab of the **Editing - By double-click** section (the **Tools** menu –**Advanced Settings**)) can be opened:

- by double-clicking on the dimension,
- by right button clicking with **CTRL** pressed on the dimension,
- by moving the cursor over the dimension and clicking the right button,

The **edit** and **fedit** commands allow you to open the **Edit dimension** dialog box, it does not matter whether **Yes** is set or not.

You can also open the **Edit dimension** dialog box:

- by placing the cursor over the dimension and selecting **Edit** in the tooltip:

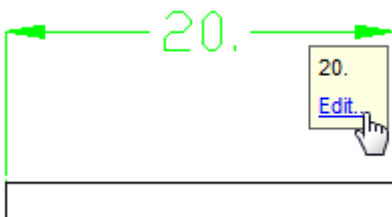

**NOTE:** To invoke the dialog this way you should choose **Yes** for the **Show tooltips** option (the **nanoCAD – Options** dialog box – the **Main option** tab – the **Tooltips** section):

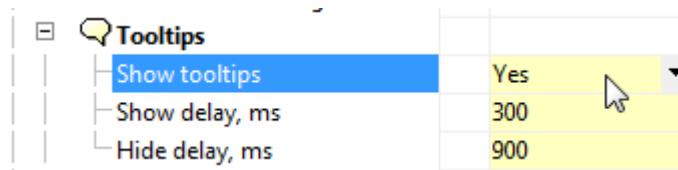

- Select dimension, press the right button and select the **Edit** command in the context menu.

The **Edit dimension** dialog box:

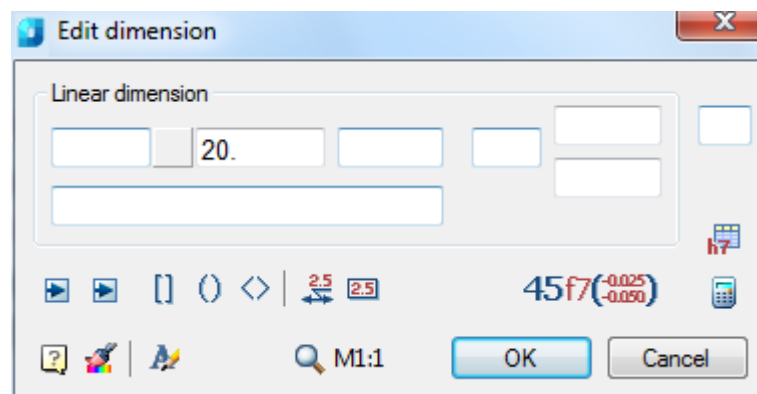

The structure of the input fields for the dimension text:

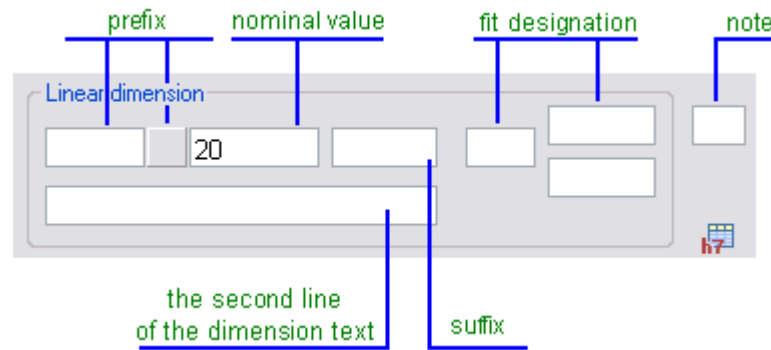

**Options:**

**Dimension type:**

In this section the dimension type (for example, *Linear dimension*, *Diameter dimension*, *Angular dimension* etc.) and values of the dimension text are displayed.

**Prefix:**

The prefix consists of the text input field and the *Symbol* button. If the dimension does not have a special symbol that is set as the default prefix, the button is displayed without an image: . Click the icon to open the panel to select a symbol:

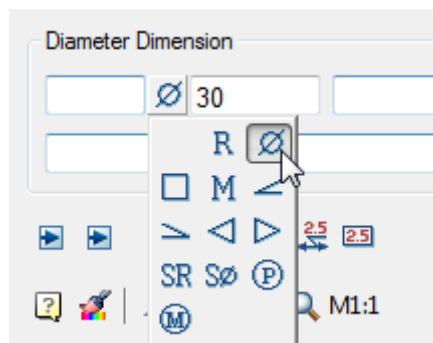

If a special symbol from the panel is set by default, it appears on the button:

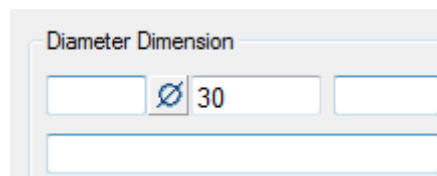

A prefix specified in the **Edit dimension** dialog box has precedence over a prefix set by default.

Example of dimension text with a prefix consisting of the text and special symbol:

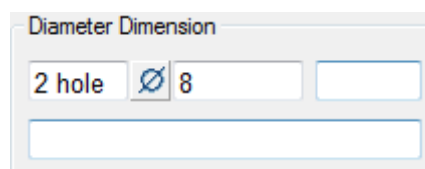

**Nominal value:**

Field to display and edit the nominal value of the dimension text.

**Suffix:** This field displays the suffix of the dimension text set by default, such as the chamfer angle designation:



In the same field, you can set the value of a custom symmetrical fit of the dimension:

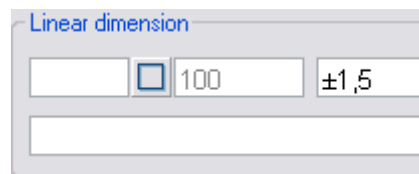

**Fit designation:**

The fields display the specified fit values of the dimension. Depending on the way the fits are written (the **Fit view** button), the values in the fields can be displayed in different ways:

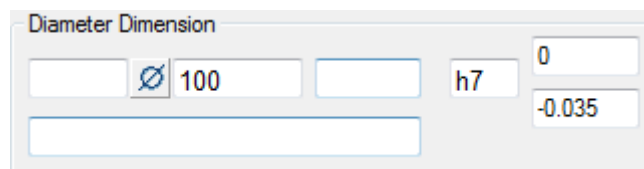
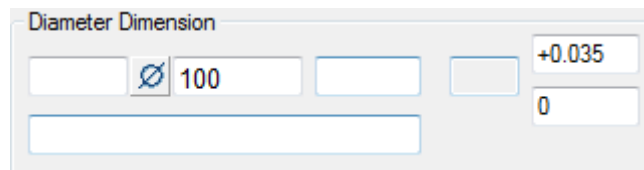
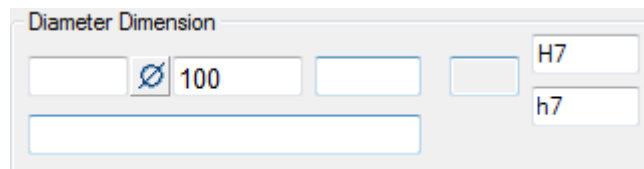

**Note:** The input field for a note for the dimension is used to create the hyperlink to the item that contains the technical conditions that define the general requirements for several dimensions. For example, in this field you can type the star symbol (\*) to denote the reference dimension (having the corresponding item in the technical conditions).

**The second line of the dimension text:**

An example displaying the dimension text consisting of two lines:



### Buttons



These buttons are used to change the arrow type. Click to open the panel and select the required arrow type:



These buttons are used to turn on/off the modes for placing text in the *Square*, *Round* or *Pointed* brackets.



<table border="1"> <tr><td>Superscript</td><td>Ctrl+Up</td></tr> <tr><td>Subscript</td><td>Ctrl+Down</td></tr> <tr><td>Insert division</td><td></td></tr> <tr><td>Pick from drawing</td><td></td></tr> <tr><td>Create hyperlink...</td><td></td></tr> <tr><td>Symbols</td><td>▶</td></tr> </table>	Superscript	Ctrl+Up	Subscript	Ctrl+Down	Insert division		Pick from drawing		Create hyperlink...		Symbols	▶	<p>The functions of the first three commands of this section are as their names suggest.</p> <p>The <b>Pick from drawing</b> command temporarily closes the <b>Edit dimension</b> dialog box and opens the <b>Value picker</b> dialog box to get different objects properties from the drawing. You can then insert them into the <b>Edit dimension</b> dialog box.</p>
Superscript	Ctrl+Up												
Subscript	Ctrl+Down												
Insert division													
Pick from drawing													
Create hyperlink...													
Symbols	▶												

The **Symbols** command allows you to insert various symbols into the input fields, including characters from the Windows table:

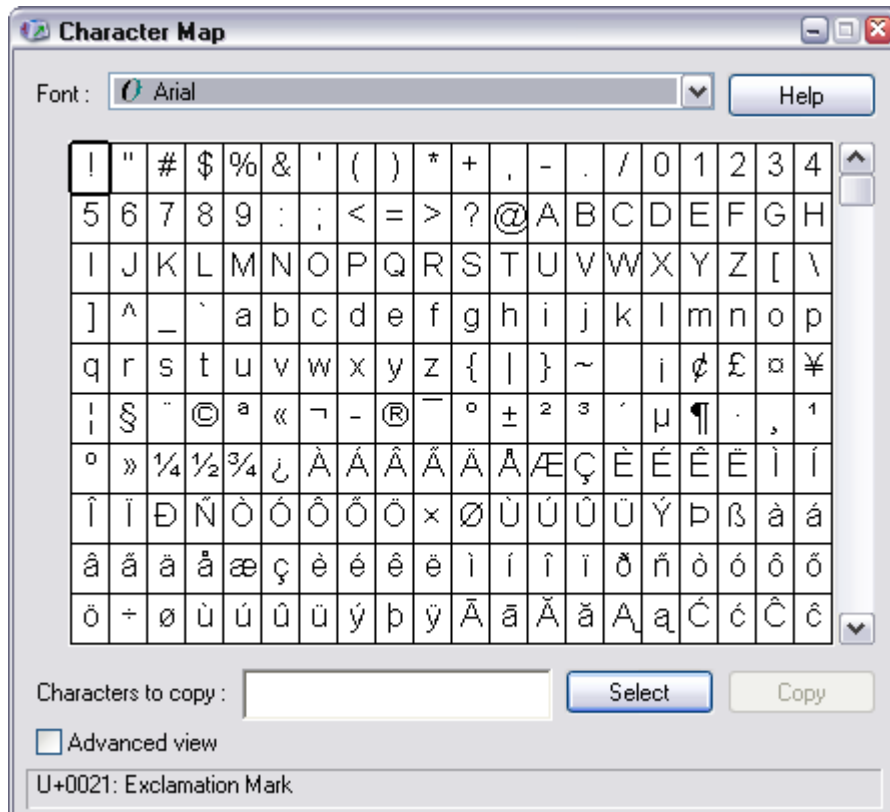

	<table border="1"> <tr><td>Undo</td><td>Ctrl+Z</td></tr> <tr><td>Cut</td><td>Ctrl+X</td></tr> <tr><td>Copy</td><td>Ctrl+C</td></tr> <tr><td>Paste</td><td>Ctrl+V</td></tr> <tr><td>Delete</td><td>Del</td></tr> <tr><td colspan="2"><hr/></td></tr> <tr><td>Select all</td><td>Ctrl+A</td></tr> </table>	Undo	Ctrl+Z	Cut	Ctrl+X	Copy	Ctrl+C	Paste	Ctrl+V	Delete	Del	<hr/>		Select all	Ctrl+A	<p>The commands from this section allow you to perform operations using the clipboard.</p>
Undo	Ctrl+Z															
Cut	Ctrl+X															
Copy	Ctrl+C															
Paste	Ctrl+V															
Delete	Del															
<hr/>																
Select all	Ctrl+A															
	<table border="1"> <tr><td>✓ 0</td></tr> <tr><td>0.0</td></tr> <tr><td>0.00</td></tr> <tr><td>0.000</td></tr> </table>	✓ 0	0.0	0.00	0.000	<p>Sets the precision of the nominal dimension.</p>										
✓ 0																
0.0																
0.00																
0.000																

**To set the dimension fit:**

1. Click the button .
2. In the panel that appears, select the method of writing the tolerances:

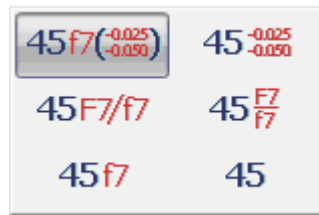

3. Click the button .
4. In the opened **Fits** dialog box, select the required values:

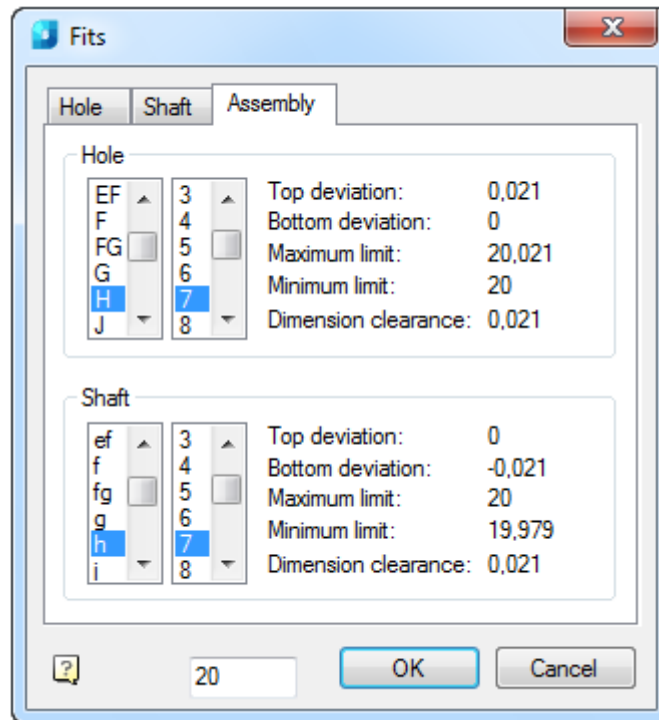

## Oblique Dimension

 Ribbon: **Home, Annotate – Dimensions >**  **Oblique dimension**

 Menu: **Dimension –**  **Oblique dimension**

 Command line: **DIMOBLIQUE**

Changes the oblique angle of dimension. The function is useful when extension lines conflict with other features of the drawing. The oblique angle is measured from the **X** axis of the UCS.

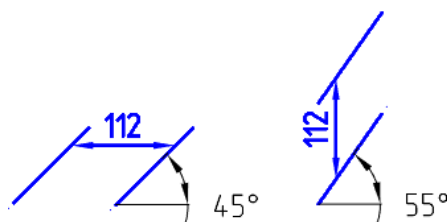

### Command prompts:

Select objects or [?]:

Select dimension objects and press **ENTER**.

Specify oblique angle (press ENTER,

Enter value or specify oblique angle on

if without oblique):

the screen.

## Break and Restore Dimensions

If necessary, you can use breaks to improve the readability of the graphical information and exclude errors in the dimensions on the drawing. The **Break dimension** command, unlike the **Explode** command from the **Modify** menu, does not break the completeness of the dimension and does not result in a loss of the association with the object.

Essentially, the **Break dimension** command does not remove the dimension part, but places a mask on it.

To break the dimension (or rather, to place the mask), it is necessary to select two points on the dimension or extension line that define the location and length of the mask.

When you edit the dimension or an object that intersects dimension, the dimension mask (break) will not be updated automatically. So after moving the dimension or editing an object that intersects dimension, you should first restore the dimension and then add a dimension mask (break) again.

### Dimension Break



Ribbon: **Home, Annotate - Dimensions** >  **Break Dimension Line**



Menu: **Dimensions** -  **Break dimension**



Toolbar: **Utilities** - 



Command line: **MDIMBREAK**

Creates a break in the dimension. When you create a break, turn on the **Nearest** snap (or switch on the **To turn the object snap "Nearest" on automatically during an insert of objects** option in the **nanoCAD - Options** dialog box on the **Main** tab of the **Edit** section (the **Tools** menu - **Settings parameters**).

#### Option:

##### Unbreak

Removes the breaks in the selected dimension.

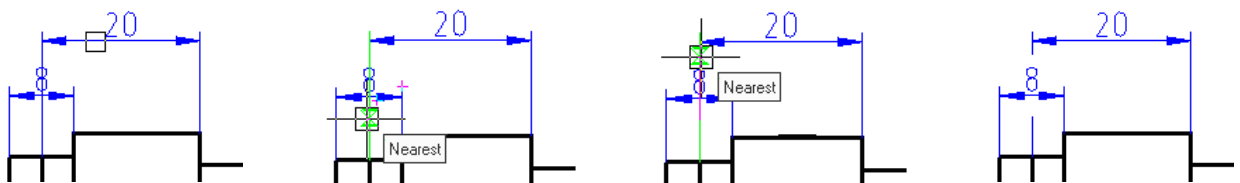

#### The following prompts are displayed:

Select dimension to break or [?]:

Select the dimension.

Select first point [Unbreak]:

Select the first point.

Select second point [Unbreak]:

Select the second point.

When you select a dimension, the **Break line** command will be available from context menu.

## Dimension Restore



Ribbon: **Home, Annotate - Dimensions** >  **Unbreak Dimension Line**



Menu: **Dimensions** –  **Restore dimension**



Toolbar: **Utilities** – 



Command line: **MDIMUNBREAK**

Removes the dimension breaks created by the **Break dimension** command.

*The following prompt is displayed:*

Select dimensions to unbreak or [?]:

Select the dimensions and press **ENTER**.

When you select dimension, the **Unbreak lines** command will be available from the context menu.

## Breaking and Unbreaking a Dimension in the Command Line



Command line: **DIMBREAK**

**Command options:**

?

Opens additional options for selecting objects.

Multi

Selects multiple dimensions to edit.

**Command prompts:**

Select dimension to add/remove break or [?/Multi]:

Select dimensions.

Select object to break dimension or [?/Auto/Manual/Remove]<Auto>:

Select an object intersecting the dimension or an option to edit the dimension.

Auto

Sets dimension line breaks automatically at all points where the dimension intersects with objects.

Manual

Specifies the location of the dimension break manually by specifying two points on the dimension line.

Remove

Removes all dimension breaks on the selected dimensions.





## Explode Dimensions

In some cases, it is necessary to explode a dimension into separate parts – lines, arrows, arcs and dimension text. To perform this operation, use the **Explode** command from the **Modify** menu.

It is strongly recommended not to explode the dimensions unless there is a specific need.



## Dimension Styles



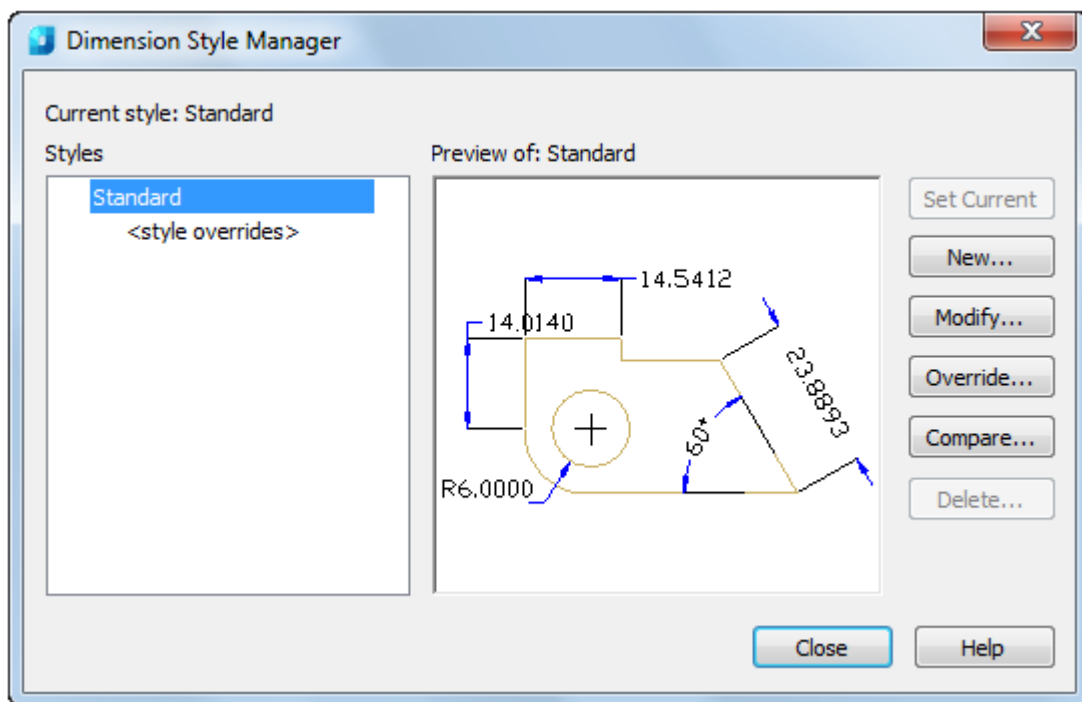

-  Ribbon: **Home - Annotation** >  **Dimension Style Manager**
-  Ribbon: **Annotate - Dimensions** >  **Dimension Style Manager**
-  Menu: **Format** -  **Dimensions styles ...**
-  Menu: **Dimensions** -  **Dimensions styles ...**
-  Toolbar: **Styles** - 
-  Command line: **DIMSTYLE, DIMSTYLESCMD**

A dimension style is a named collection of dimension settings that control the appearance of dimensions, such as arrowhead style, text location and lateral tolerances.

Controlling of the dimension styles is carried out in the **Dimension Style Manager** dialog box:

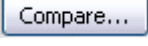

### Options:

- |   |   |
|---|---|
| <b>Current style:</b>   | Displays the name of the current dimension style.   |
| <b>Styles:</b>  | Displays a list of the dimension styles in the drawing.                                   |
| <b>Preview of:</b>  | Shows a graphic representation of the style selected in the <b>Styles</b> list.           |
|  | Sets the style selected under Styles as the current one.                                  |
|  | Displays the <b>Creating style</b> dialog box where you can define a new dimension style. |
|  | Changes the options for the style selected in the list.                                   |
|  | Changes the options for the current dimension style.                                      |
|  | Compares the properties of two dimension styles.  |



Deletes the selected dimension style.

**To set the current dimension style:**

1. Select the required style from the **Styles** list.
2. Click the **Set Current** button.

**To create a new dimension style:**

1. In the **Styles** list, select the style from which you want to create a new one.
2. Click the **New** button.
3. In the **Creating style** dialog box, type a name for the new style:

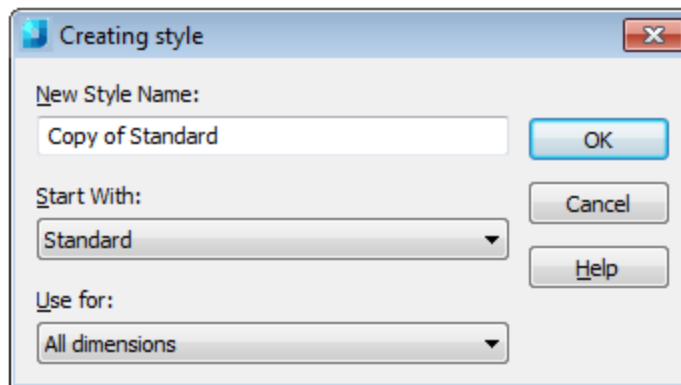

**Options:**

**New style name:**

Specifies the new dimension style name.

**Start with:**

Sets the style to use as a basis for the new one.

**Use for:**

Creates a *dimension sub style* that applies only to specific dimension types.

The following *sub styles* are available:

- All dimensions
- Linear dimensions
- Angular dimensions
- Diameter dimensions
- Radial dimensions
- Ordinate dimensions
- Leader dimensions

4. Click **OK**.
5. In the **Modify dimension style** dialog box that appears, set the required options for the new dimension style.

**To modify a dimension style:**

1. In the **Styles** list, select the required style.
2. Click the **Modify** button.
3. In the **Modify dimension style** dialog box that appears, set the new options for the dimension style to be modified.

**To change the options for the current dimension style:**

1. In the **Styles** list, select the current dimension style (if you select any other style, the **Override** button will not be available).
2. Click the **Override** button.
3. In the **Modify dimension style** dialog box that appears, override the options for the current dimension style.

**To compare two dimension styles:**

1. In the **Styles** list, select the first dimension style which you want to compare.
2. Click the **Compare** button.
3. In the **Compare Dimension Styles** dialog box, from the **With** list select the second dimension style for comparing:

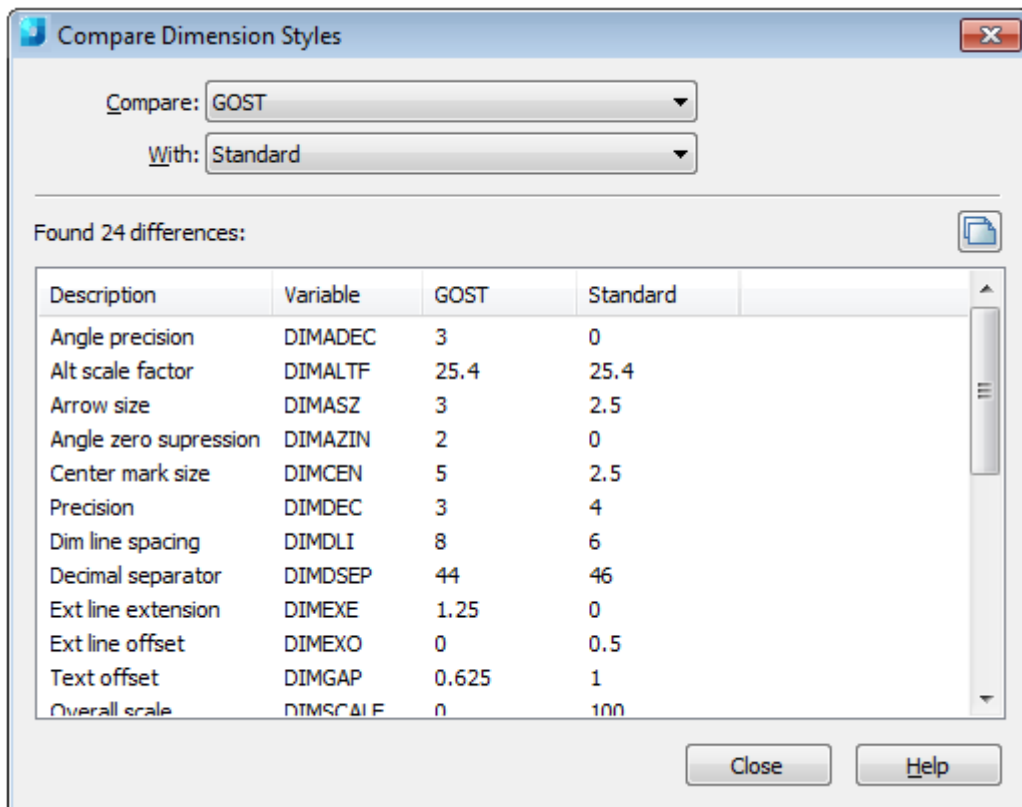

**Options:**

**Compare:** Drop-down list to select the first dimension style for comparing.

**With:** Drop-down list to select the second dimension style for comparing.

**Found differences:**

**Description:** List of the properties of the compared dimension styles.

**Variable:** List of the dimension variables that define the compared properties.



Use this button to copy the comparison results to the clipboard.

The **Compare Dimension Styles** dialog box can be used to view a list of all the properties of any dimension style. To do this, select the same dimension style in the **Compare** and **With** lists:

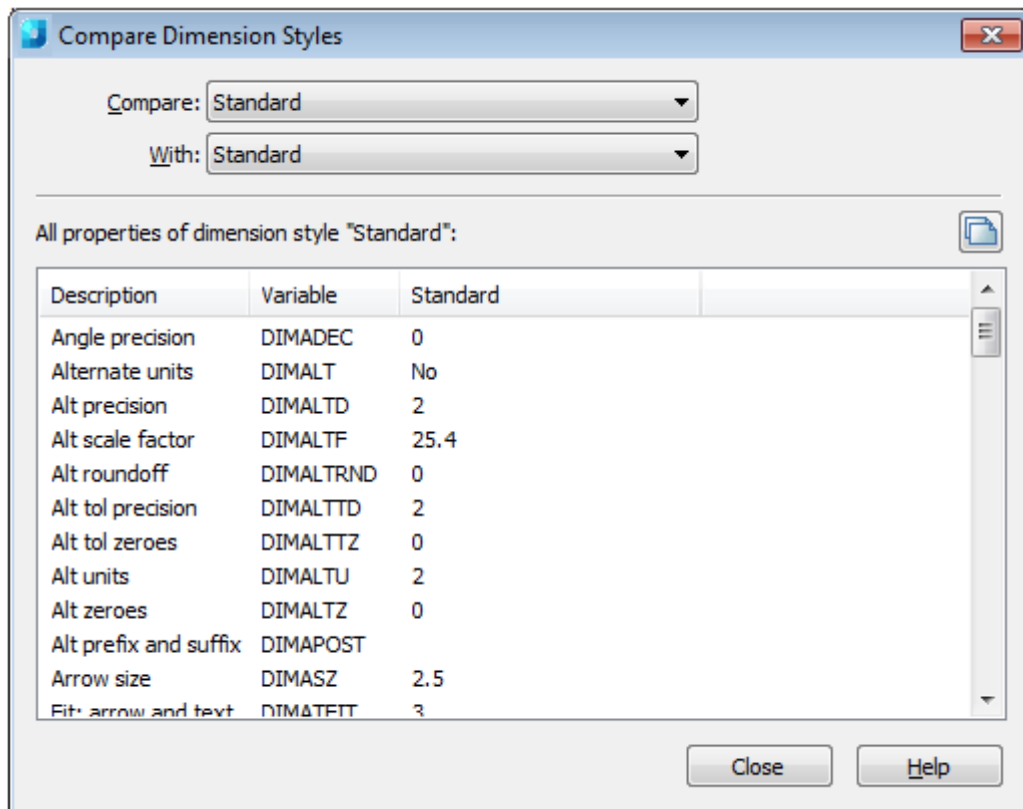

### To delete a dimension style:

1. In the **Styles** list, select the style that you want to delete.
2. Click the **Delete** button.

## Modify a Dimension Style

The properties of new dimensions are set and options for existing dimension styles are modified in the **Modify dimension style** dialog box.

The name of the dimension style being modified is displayed in the dialog box title:

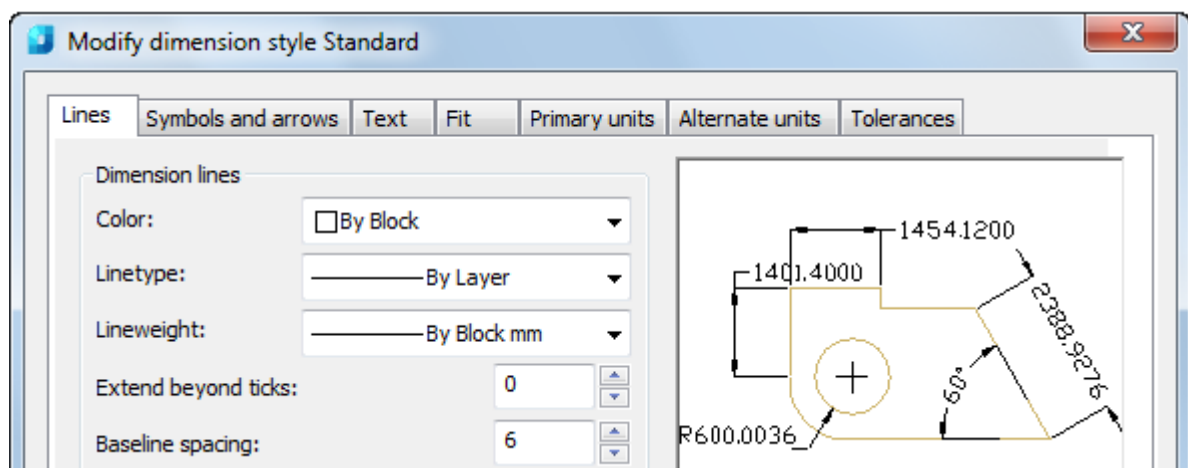

The **Modify dimension style** dialog box contains the following tabs:

- **Lines**
- **Symbols and arrows**
- **Text**
- **Fit**

- **Primary units**
- **Alternate units**
- **Tolerance**

The window in the upper right corner of each tab displays a graphical preview of the properties of the dimension style being modified.

## The “Lines” Tab

Sets the properties of dimension lines and extension lines:

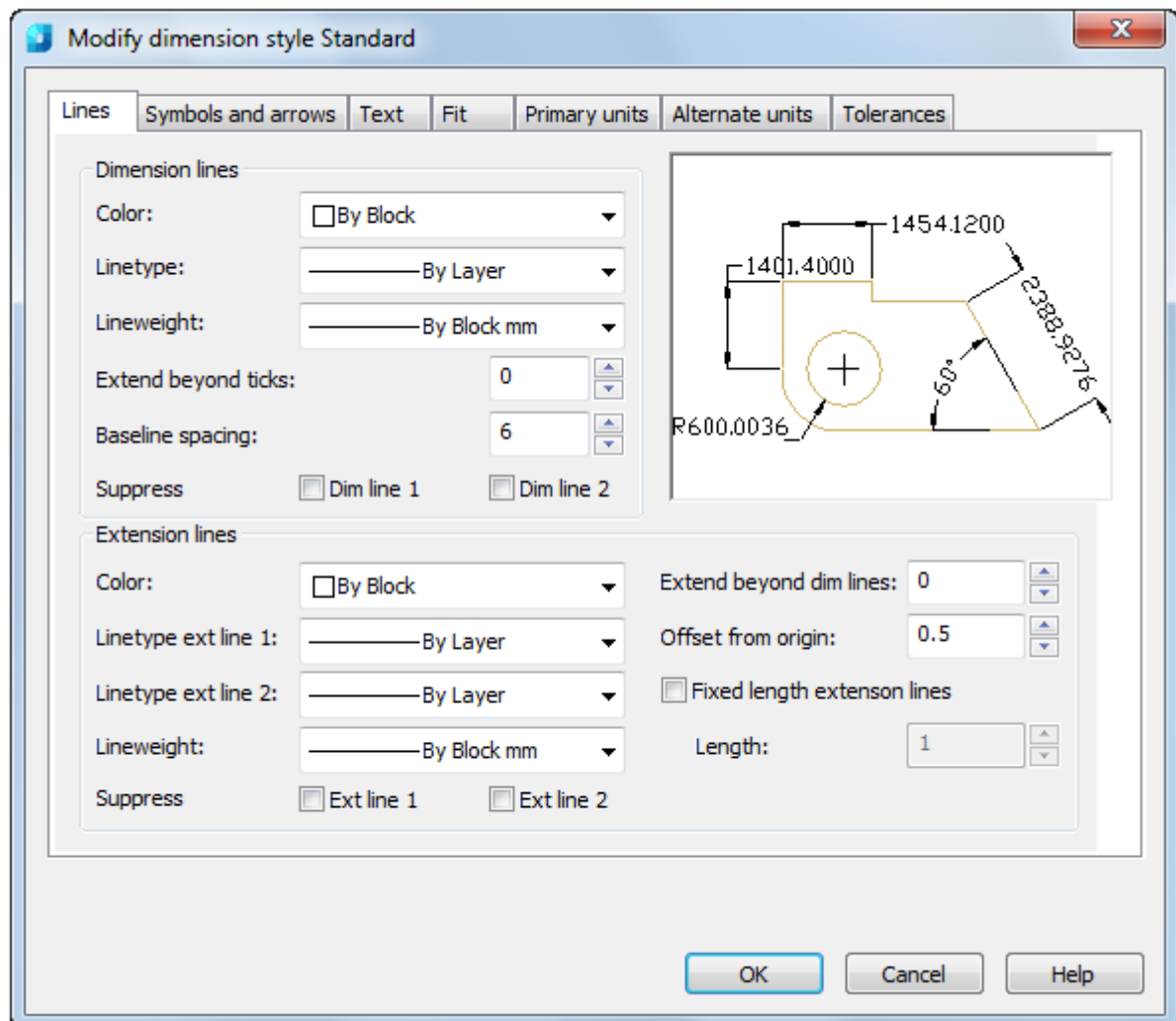

### Options:

#### Dimension lines

- Color:** Displays and sets the color for the dimension line.
- Linetype:** Sets the linetype of the dimension line.
- Lineweight:** Sets the lineweight of the dimension line.

**Extend beyond ticks:**

Specifies the distance to extend the dimension line past the extension line when you use ticks and no marks for arrowheads.

**Examples:**

1. Extend beyond ticks: **2**

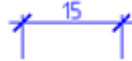

2. Extend beyond ticks: **0**

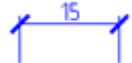

**Baseline spacing:**

Sets the spacing between the dimension lines of a baseline dimension.



**Suppress: Dim line 1, Dim line 2**

Suppresses the display of dimension lines.

**Examples:**

1. Dim Line 1 suppresses the first dimension

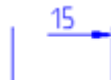

2. Dim Line 2 suppresses the second dimension line

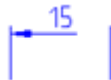

*Extension lines*

**Color:**

Sets the color for the extension lines.

**Linetype ext line 1:**

Sets the linetype of the first extension line.

**Linetype ext line 2:**

Sets the linetype of the second extension line.

**Lineweight:**

Sets the lineweight of the extension line.

**Suppress: Ext line 1, Ext line 2**

Suppresses the display of extension lines.

**Examples:**

1. Ext Line 1 suppresses the first extension line

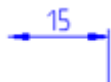

2. Ext Line 2 suppresses the second extension line



**Extend beyond dim lines:**

Specifies the distance to extend the extension lines above the dimension line.

*Examples:*

1. Extend beyond dimension line: **1.25**

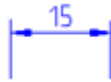

2. Extend beyond dimension line: **0**

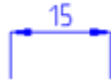

**Offset from origin:**

Sets the distance to offset the extension lines from the points on the drawing (object) that define the dimension.

*Examples:*

1. Offset from object: **0.625**



2. Offset from object: **0**



**Fixed Length Extension Lines**

Enables fixed length extension lines.

**Length:**

Sets the total length of the extension lines.

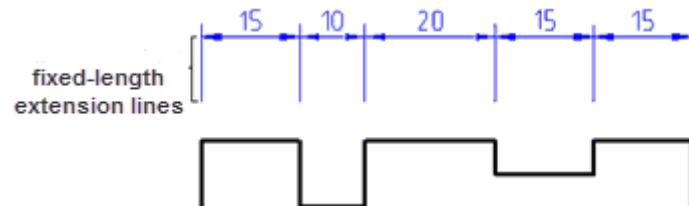

**The “Symbols and Arrows” Tab**

Sets the format and placement for arrowheads, center marks, arc length symbols and jogged radius dimensions:

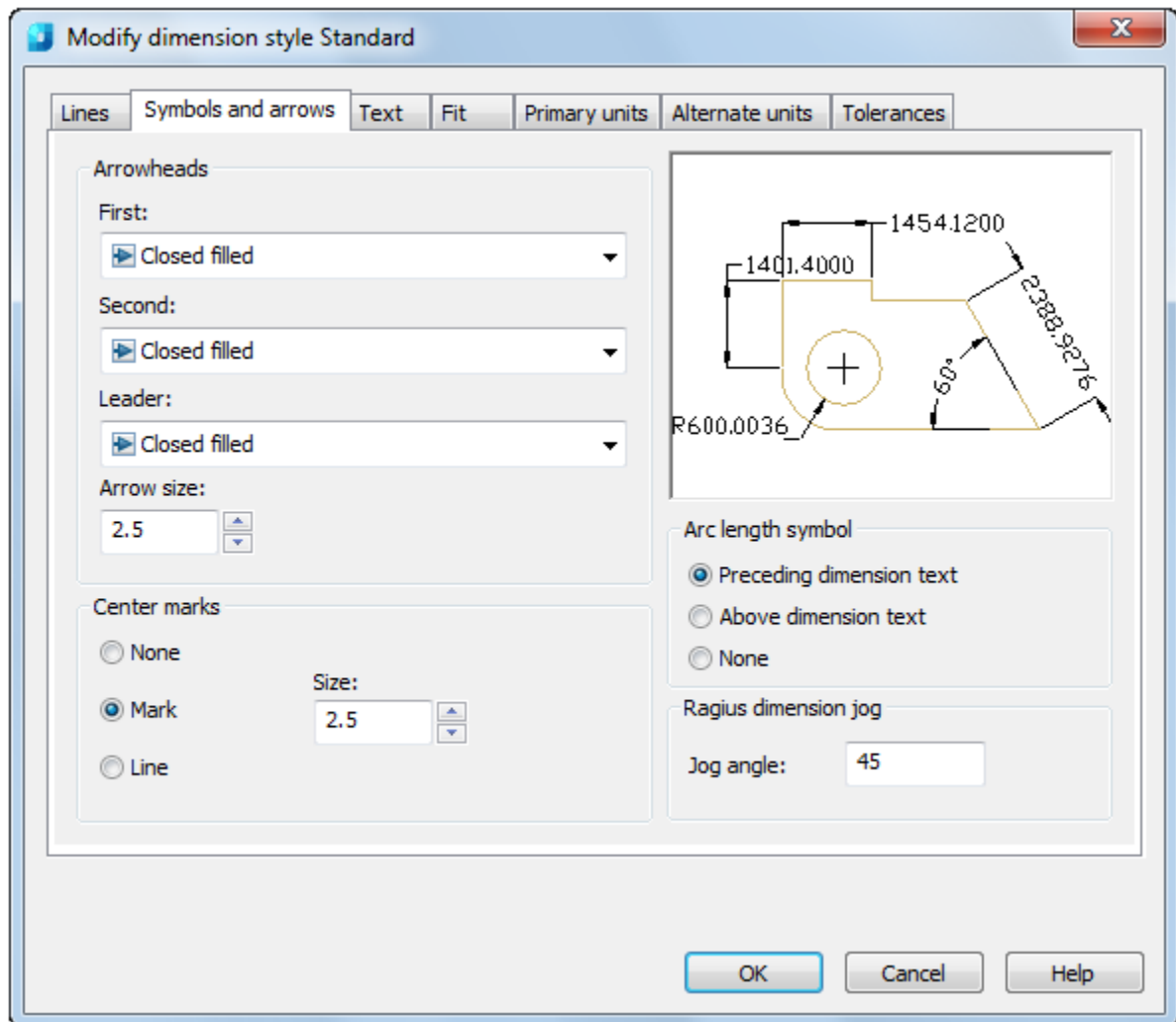

### Options:

#### Arrowheads

- First:** Sets the arrowhead for the first dimension line. When you change the first arrowhead type, the second arrowhead automatically changes to match it.
- Second:** Sets the arrowhead for the second dimension line. When you change the second arrowhead type, the first arrowhead does not automatically change to match it.
- Leader:** Sets the arrowhead for the leader line.
- Arrow size:** Displays and sets the size of arrowheads.

#### Center marks

- None:** Creates no center mark or centreline.
- Mark:** Creates a center mark.
- Line:** Creates a centerline.
- Size:** Displays and sets the size of the center mark or centreline.

#### Arc length symbol

- Preceding Dimension Text:** Places arc length symbols before the dimension text.



- Above Dimension Text:** Places arc length symbols above the dimension text.
- None:** Suppresses the display of arc length symbols.

*Radius dimension jog*

- Jog angle:** Determines the angle of the transverse segment of the dimension line in a jogged radius dimension.

## The “Text” Tab

Sets the format, placement, and alignment of dimension text:

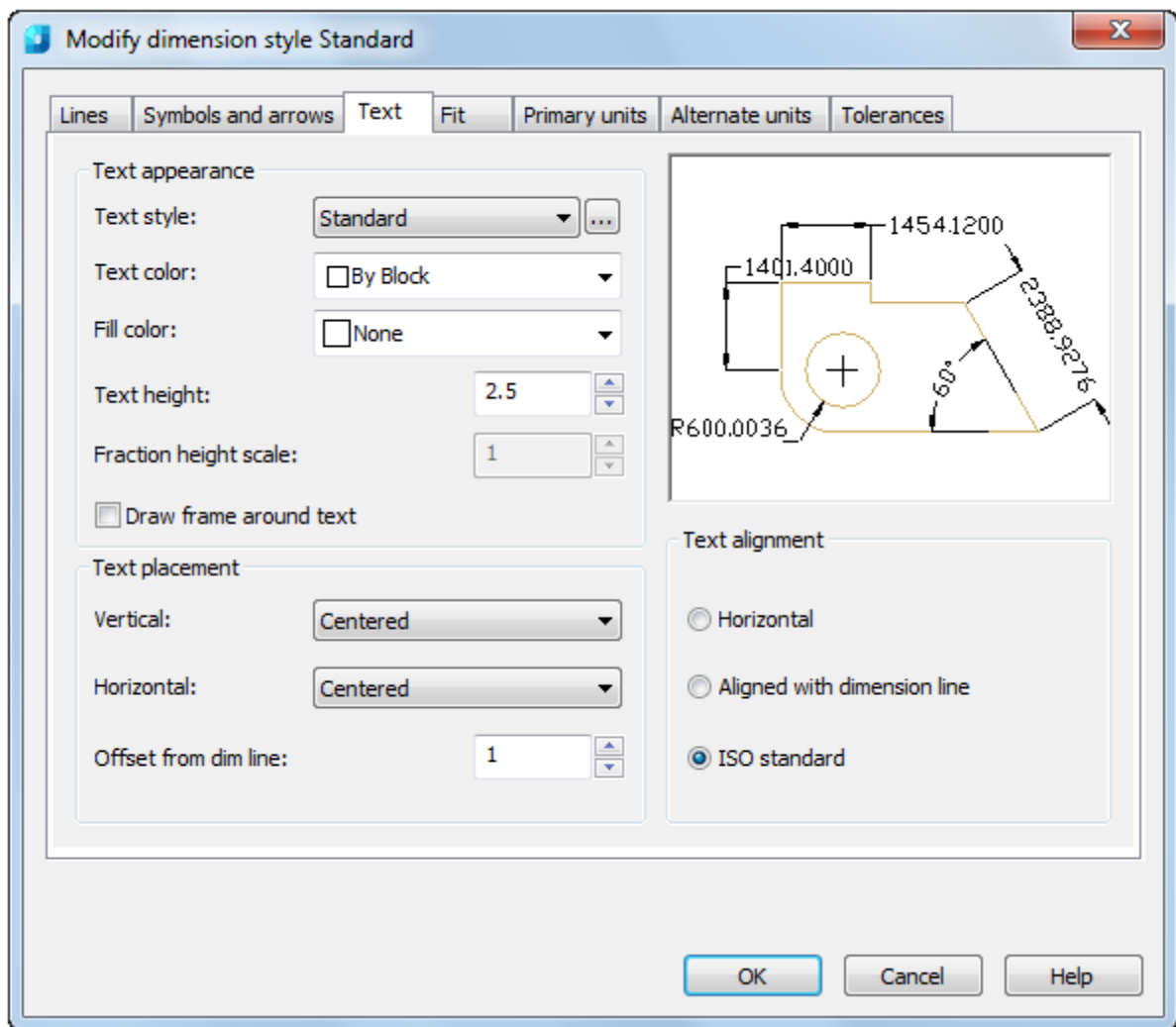

**Options:**

*Text appearance*

- Text style:** Lists the available text styles.  
 Displays the **Text styles** dialog box where you can create or modify text styles.
- Text color:** Sets the color for the dimension text.
- Fill color:** Sets the color for the text background in dimensions.

**Text height:** Sets the height of the current dimension text style.  
If a fixed text height is set in the Text Style (that is, the text style height is greater than **0**), that height overrides the text height set here.

**Fraction height scale:** Sets the scale of fractions relative to the dimension text.  
This option is available only when **Fractional** is selected as the **Unit Format** on the **Primary Units** tab. The value entered here is multiplied by the text height to determine the height of dimension fractions relative to dimension text.

**Draw frame around text**  
When selected, draws a frame around the dimension text.

*Text placement*

**Vertical:** Controls the vertical placement of the dimension text in relation to the dimension line:

- **Centered** – Centres the dimension text between the two parts of the dimension line.



- **Above** - Places the dimension text above the dimension line. The distance from the dimension line to the baseline of the lowest line of text is the current text gap.



- **Outside** - Places the dimension text on the side of the dimension line farthest away from the first defining point.



- **JIS** - Places the dimension text to conform to a Japanese Industrial Standards (JIS) representation.

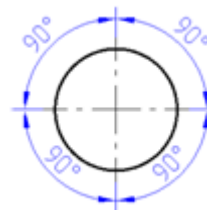

**Horizontal:**

Controls the horizontal placement of the dimension text along the dimension line in relation to the extension lines:

- **Centered** – Centers the dimension text along the dimension line between the extension lines.

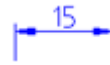

- **At Ext Line 1** - Left justifies the text with the first extension line along the dimension line. The distance between the extension line and the text is twice the arrowhead size plus the text gap value.

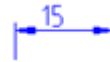

- **At Ext Line 2** - Right justifies the text with the second extension line along the dimension line. The distance between the extension line and the text is twice the arrowhead size plus the text gap value.

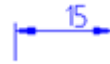

- **Over Ext Line 1** - Positions the text over or along the first extension line.



- **Over Ext Line 2** - Positions the text over or along the second extension line.



**Offset from dim line:**

Sets the current text gap, which is the distance around the dimension text when the dimension line is broken to accommodate the dimension text.

This value is also used as the minimum length required for dimension line segments.

Text is positioned inside the extension lines only if the resulting segments are at least as long as the text gap. Text above or below the dimension line is placed inside only if the arrowheads, dimension text and a margin leave enough room for the text gap.

**Examples:**

1. Offset from dim line: **0.625**



2. Offset from dim line: **0**



*Text alignment*

**Horizontal:**

Places text in a horizontal position.



**Aligned with dimension line:**

Aligns text with the dimension line.

**ISO standard:**

Aligns text with the dimension line when text is inside the extension lines, but aligns it horizontally when text is outside the extension lines.



## The “Fit” Tab

Controls the placement of the dimension text, arrowheads, leader lines and the dimension line:

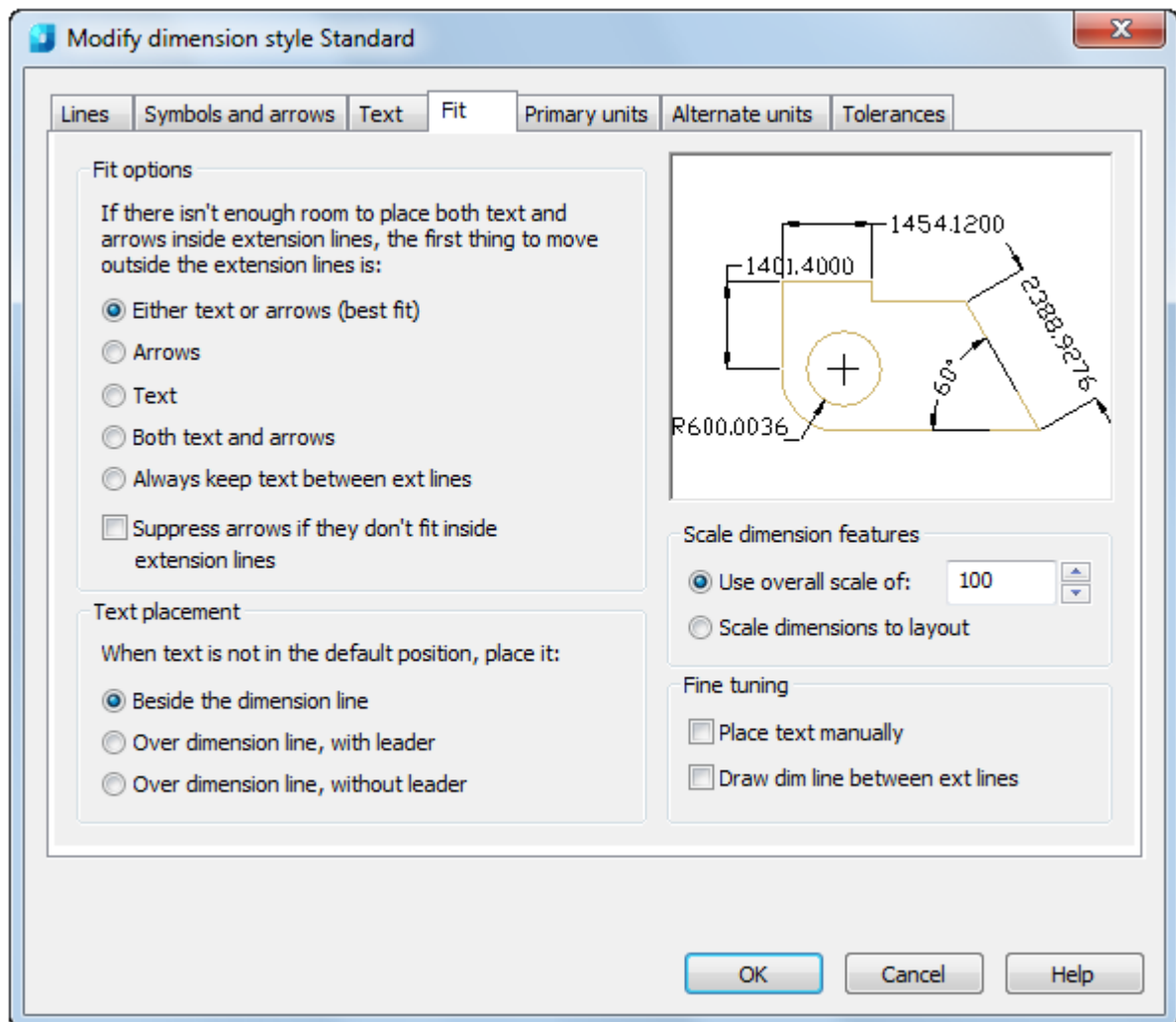

**Options:**

*Fit options*

Controls the placement of text and arrowheads based on the space available between the extension lines.

**Either text or arrows (best fit):**

Moves either the text or the arrowheads outside the extension lines based on the best fit.

**Arrows:**

Moves the arrowheads outside the extension lines first, then the text.

**Text:** Moves the text outside the extension lines first, then the arrowheads.



**Both text and arrows:** When not enough space is available for text and arrowheads, both are moved outside the extension lines.



**Always keep text between ext lines:** Always places the text between the extension lines.

**Suppress arrows if they don't fit inside extension lines:** Suppresses arrowheads if not enough space is available inside the extension lines.

*Text placement*

Sets the placement of the dimension text when it is moved from the default position; that is, the position defined by the dimension style.

**Beside the dimension line:** If selected, moves the dimension line whenever the dimension text is moved.



**Over dimension line, with leader:** If selected, dimension lines are not moved when text is moved. If text is moved away from the dimension line, a leader line is created connecting the text to the dimension line. The leader line is omitted when text is too close to the dimension line.

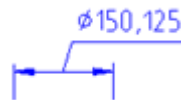

**Over dimension line, without leader:** If selected, dimension lines are not moved when text is moved.



*Scale dimension features*

**Use overall scale of:** Sets a scale for all dimension style settings that specify size, distance or spacing, including text and arrowhead sizes.

**Scale dimensions to layout:** Determines a scale factor based on the scaling between the current model space viewport and the paper space.

*Fine tuning*

**Place text manually:** Places the text at the position you specify at the Dimension Line Location prompt.

Ignores any horizontal justification settings.

**Draw dim line between ext lines:** Draws dimension lines between the measured points, even when the arrowheads are placed outside the measured points.

## The “Primary Units” Tab

Sets the format and precision of the primary dimension units and sets prefixes and suffixes for the dimension text:

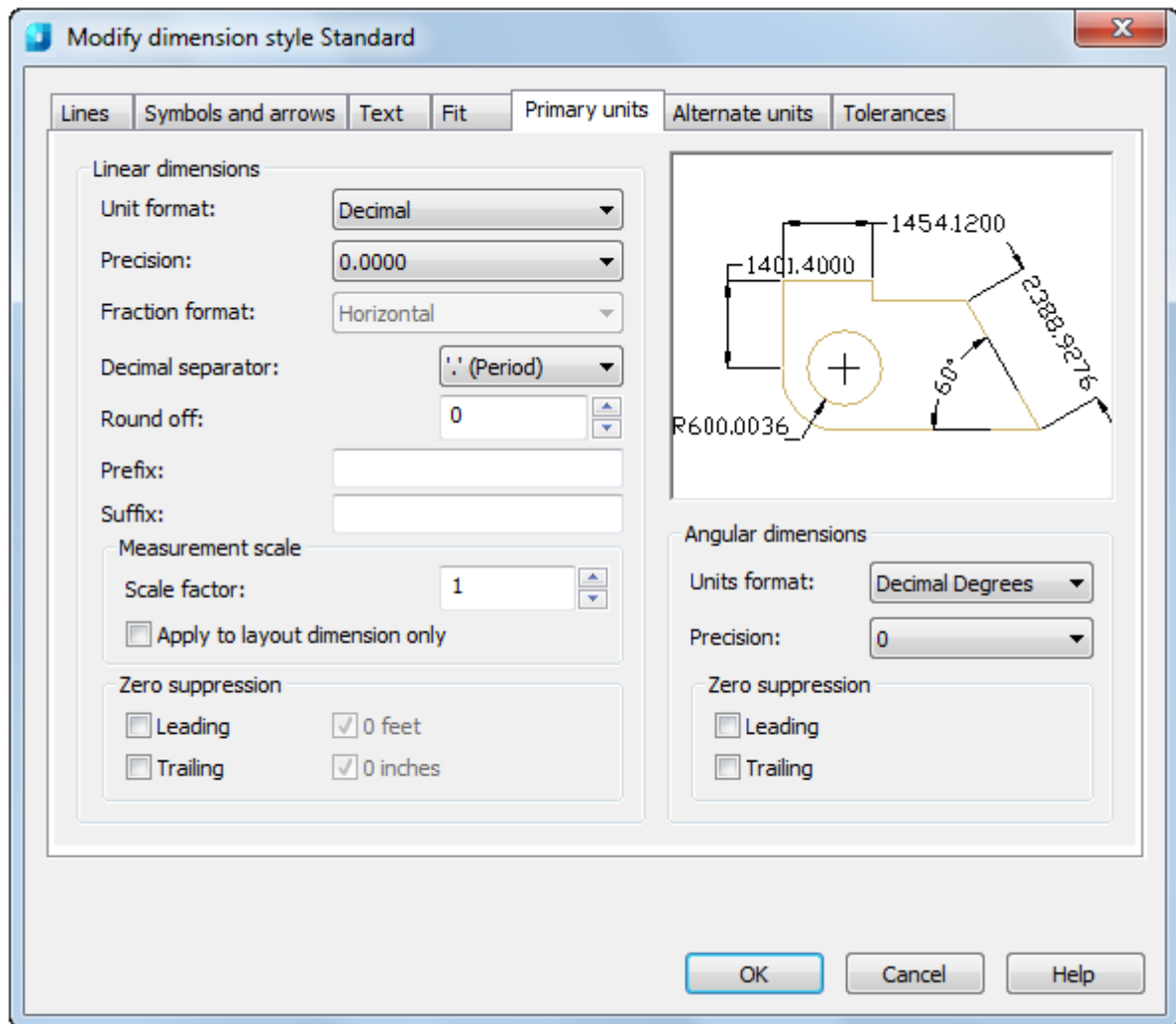

### Options:

#### Linear dimensions

- Unit format:** Sets the current units format for all dimension types except Angular.
- Precision:** Displays and sets the number of decimal places in the dimension text.
- Fraction format:** Sets the format for fractions. Options are available if you have set the **Fractional** or **Architectural** values in the **Unit format** option.
- Decimal separator:** Sets the separator for decimal formats. Options are available if you have set the **Decimal** value in the **Unit format** option.
- Round off:** Sets rounding rules for dimension measurements for all dimension types except Angular.

#### For example:

1. If you enter a value of **0.25**, all distances are rounded to the nearest **0.25** unit.
  2. If you enter a value of **1.0**, all dimension distances are rounded to the nearest integer.
- The number of digits displayed after the decimal point depends on the **Precision** setting.

**Prefix:** Includes a prefix in the dimension text.  
You can enter text or use control codes to display special symbols.

**For example:**

Entering the control code %%c displays the diameter symbol.  
When you enter a prefix, it overrides any default prefixes such as those used in diameter and radius dimensioning.



**Suffix:** Includes a suffix in the dimension text.  
You can enter text or use control codes to display special symbols.  
When you enter a suffix, it overrides any default suffixes.



*Measurement scale*

**Scale factor:** Defines the linear scale options.  
Scale factor set by default – **1**.

**For example:**

If you enter **2**, the dimension for a *100* millimetre line is displayed as *200* millimetres.

The value does not apply to angular dimensions and is not applied to rounding values or to plus or minus tolerance values.

**Apply to layout dimension only:** Applies the measurement scale factor only to dimensions created in layout viewports.  
Except when using non-associative dimensions, this setting should remain unchecked.

*Zero suppression*

**Leading:** Suppresses leading zeros in all decimal dimensions.

**For example:**

0.3000 becomes .3000.

**Trailing:** Suppresses trailing zeros in all decimal dimensions.

**For example:**

30.0000 becomes 30.

**0 feet:** Suppresses the feet portion of a feet-and-inches dimension when the distance is less than one foot.

**For example:**

0'-6 1/2" becomes 6 1/2".

Options are available if you have set the **Engineering** or **Architectural** values in the **Unit format** option.

**0 inches:** Suppresses the inches portion of a feet-and-inches dimension when the distance is an integral number of feet.

**For example:**

1'-0" becomes 1'.

Options are available if you have set the **Engineering** or **Architectural** values in the **Unit format** option.

### Angular dimensions

- Unit format:** Sets the angular units format.
- Precision:** Sets the number of decimal places for angular dimensions.

### Zero suppression

- Leading:** Suppresses leading zeros in angular decimal dimensions.

**For example:**

0.3000 becomes .3000.

- Trailing:** Suppresses trailing zeros in angular decimal dimensions.

**For example:**

30.0000 becomes 30.

## The “Alternate Units” Tab

Specifies the display of alternative units in dimension measurements and sets their format and precision:

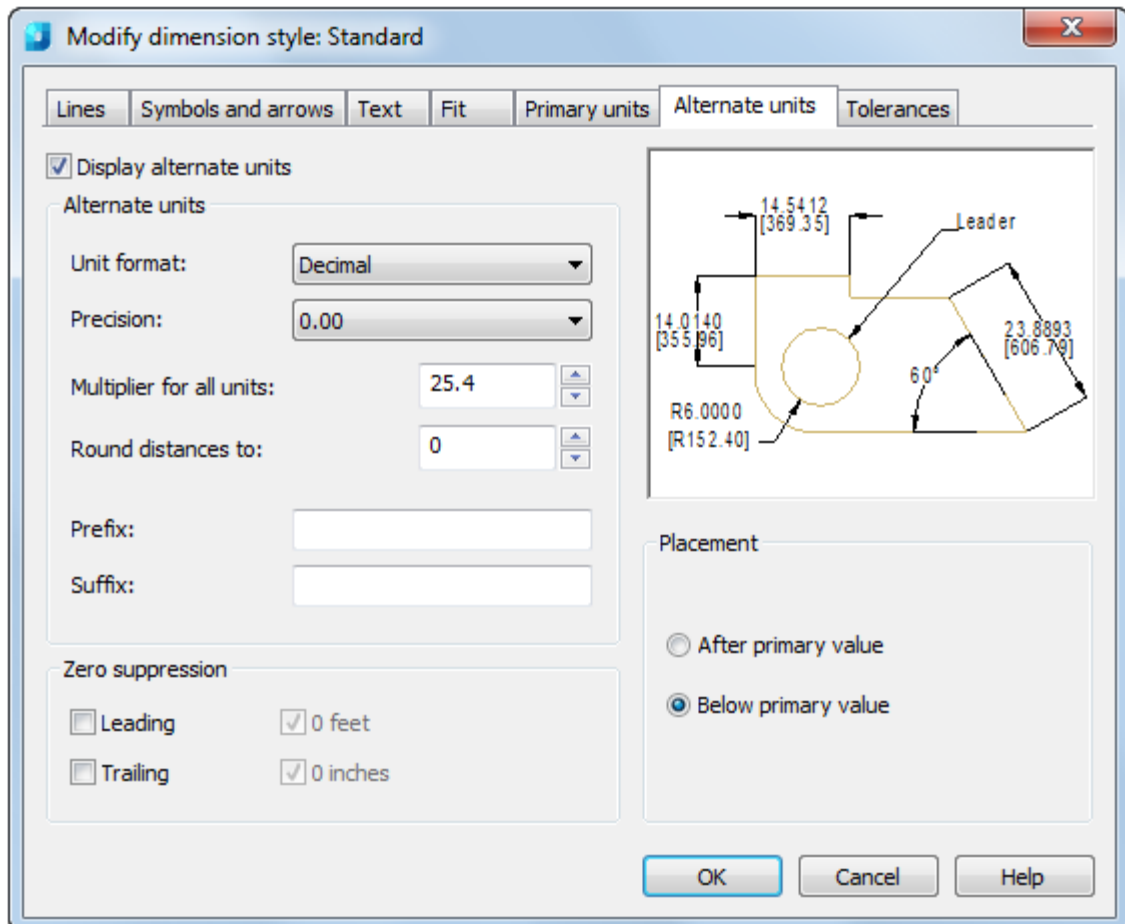



### Options:

- Display alternate units:** Adds alternative measurement units to the dimension text.

### Alternate units

- Unit format:** Sets the unit format for alternative units.



<b>Precision:</b>	Sets the number of decimal places for alternative units.
<b>Multiplier for all units:</b>	<p>Specifies the multiplier used as the conversion factor between primary and alternative units.</p> <p><i>For example:</i></p> <p>To convert inches to millimetres, enter <b>25.4</b>.</p> <p>The value has no effect on angular dimensions and it is not applied to the rounding value or the plus or minus tolerance values.</p>
<b>Round distance to:</b>	<p>Sets rounding rules for alternative units for all dimension types except Angular.</p> <p><i>For example:</i></p> <ol style="list-style-type: none"> <li>1. If you enter a value of <b>0.25</b>, all alternate measurements are rounded to the nearest <b>0.25</b> unit.</li> <li>2. If you enter a value of <b>1.0</b>, all dimension measurements are rounded to the nearest integer.</li> </ol> <p>The number of digits displayed after the decimal point depends on the <b>Precision</b> setting.</p>
<b>Prefix:</b>	<p>Includes a prefix in the alternative dimension text.</p> <p>You can enter text or use control codes to display special symbols.</p> <p><i>For example:</i></p> <p>Entering the control code <b>%%c</b> displays the diameter symbol.</p> <p>When you enter a prefix, it overrides any default prefixes such as those used in diameter and radius dimensioning.</p>  <p style="text-align: center;"><math>\phi 1.00^* [\phi 25.4\text{MM}]</math></p>
<b>Suffix:</b>	<p>Includes a suffix in the alternative dimension text.</p> <p>You can enter text or use control codes to display special symbols.</p> <p>When you enter a suffix, it overrides any default suffixes.</p>  <p style="text-align: center;"><math>2.00f1 [60.96\text{cm}]</math></p>
<i>Zero suppression</i>	
<b>Leading:</b>	<p>Suppresses leading zeros in all decimal dimensions.</p> <p><i>For example:</i></p> <p>0.3000 becomes .3000.</p>
<b>Trailing:</b>	<p>Suppresses trailing zeros in all decimal dimensions.</p> <p><i>For example:</i></p> <p>30.0000 becomes 30.</p>
<b>0 feet:</b>	<p>Suppresses the feet portion of a feet-and-inches dimension when the distance is less than 1 foot.</p> <p><i>For example:</i></p> <p>0'-6 1/2" becomes 6 1/2".</p> <p>Options are available if you have set the <b>Engineering</b> or <b>Architectural</b> values in the <b>Unit format</b> option.</p>

**0 inches:** Suppresses the inches portion of a feet and inches dimension when the distance is an integral number of feet.

*For example:*

1'-0" becomes 1'.

Options are available if you have set the **Engineering** or **Architectural** values in the **Unit format** option.

*Placement*

**After primary value:** Places the alternative units after the primary units in the dimension text.

**Below primary value:** Places the alternative units below the primary units in the dimension text.

### The “Tolerances” Tab

Controls the display and format of the dimension text tolerances:

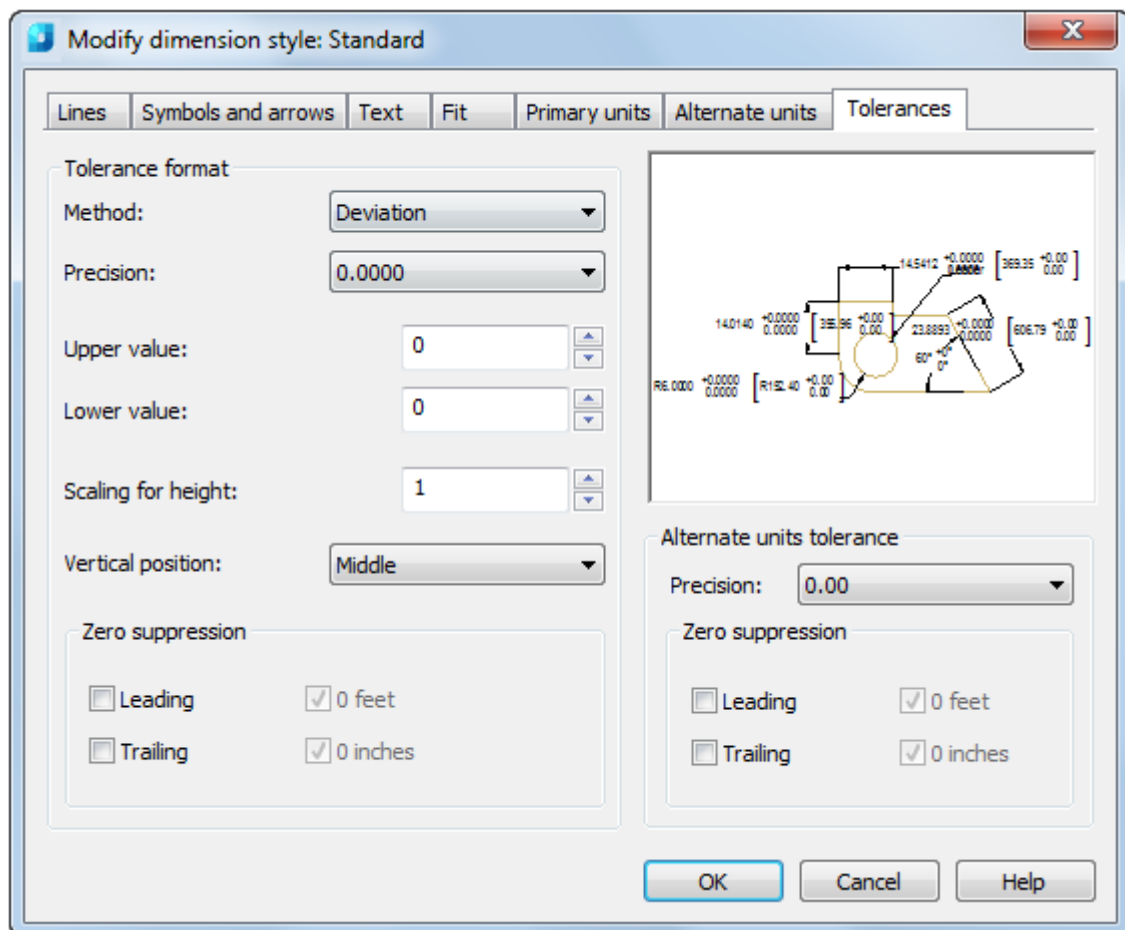

*Option:*

*Tolerance format*

**Method:** Sets the method for calculating the tolerance:

- **None** - Does not add a tolerance.



- **Symmetrical** – Adds a plus/minus expression of tolerance in which a single value of variation is applied to the

dimension measurement. A plus-or-minus sign appears after the dimension. Enter the tolerance value in **Upper Value**.

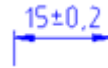

- **Deviation** – Adds a plus/minus tolerance expression. A plus sign (+) precedes the tolerance value entered in Upper Value, and a minus sign (-) precedes the tolerance value entered in **Lower Value**.

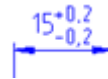

**NOTE:** If you input a minus sign (-) before an upper maximum deviation value, the value will be displayed with a minus sign (-) on the drawing.

**NOTE:** If you input a minus sign (-) before a lower maximum deviation value, the value will be displayed with a plus sign (+) on the drawing.

- **Limits** – Creates a limit dimension. A maximum and a minimum value are displayed, one over the other. The maximum value is the dimension value plus the value entered in **Upper Value**. The minimum value is the dimension value minus the value entered in **Lower Value**.

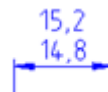

- **Basic** – Creates a basic dimension, which displays a box around the full extent of the dimension.



<b>Precision:</b>	Sets the number of decimal places.
<b>Upper value:</b>	Sets the maximum or upper tolerance value. When you select <b>Symmetrical</b> in Method, this value is used for the tolerance.
<b>Lower value:</b>	Sets the minimum or lower tolerance value.
<b>Scaling for height:</b>	Sets the current height for the tolerance text. The ratio of the tolerance height to the main dimension text height is calculated.
<b>Vertical position:</b>	Controls the text justification for symmetrical and deviation tolerances:

- **Bottom** - Aligns the tolerance text with the bottom of the main dimension text.

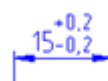

- **Middle** - Aligns the tolerance text with the middle of the main dimension text.

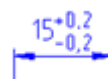

- **Top** - Aligns the tolerance text with the top of the main

dimension text.

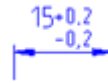

### Zero suppression

- Leading:** Suppresses leading zeros in all decimal dimensions.  
*For example:*  
*0.3000* becomes *.3000*.
- Trailing:** Suppresses trailing zeros in all decimal dimensions.  
*For example:*  
*30.0000* becomes *30*.
- 0 feet:** Suppresses the feet portion of a feet and inches dimension when the distance is less than 1 foot.  
*For example:*  
*0'-6 1/2"* becomes *6 1/2"*.  
 Options are available if you have set the **Engineering** or **Architectural** values in the **Unit format** option.
- 0 inches:** Suppresses the inches portion of a feet-and-inches dimension when the distance is an integral number of feet.  
*For example:*  
*1'-0"* becomes *1'*.  
 Options are available if you have set the **Engineering** or **Architectural** values in the **Unit format** option.

### Alternate units tolerance

- Precision:** Displays and sets the number of decimal places.

### Zero suppression

- Leading:** Suppresses leading zeros in all decimal dimensions.  
*For example:*  
*0.3000* becomes *.3000*.
- Trailing:** Suppresses trailing zeros in all decimal dimensions.  
*For example:*  
*30.0000* becomes *30*.
- 0 feet:** Suppresses the feet portion of a feet-and-inches dimension when the distance is less than 1 foot.  
*For example:*  
*0'-6 1/2"* becomes *6 1/2"*.  
 Options are available if you have set the **Engineering** or **Architectural** values in the **Unit format** option.

**0 inches:** Suppresses the inches portion of a feet-and-inches dimension when the distance is an integral number of feet.

*For example:*

1'-0" becomes 1'.

Options are available if you have set the **Engineering** or **Architectural** values in the **Unit format** option.

## Multileader

### Creating a Multileader

-  Ribbon: **Home, Annotate- Leaders -**  **Multileader**
-  Menu: **Draw >**  **Mleader...**
-  Toolbar: **Mleaders -** 
-  Command line: **MLEADER**

Multileader is a drawing drafting object and, as a rule, is a straight line or a spline with an arrow at one end and multiline text object or block at the other. A text or block are connected with the leader line by a short horizontal line – landing.

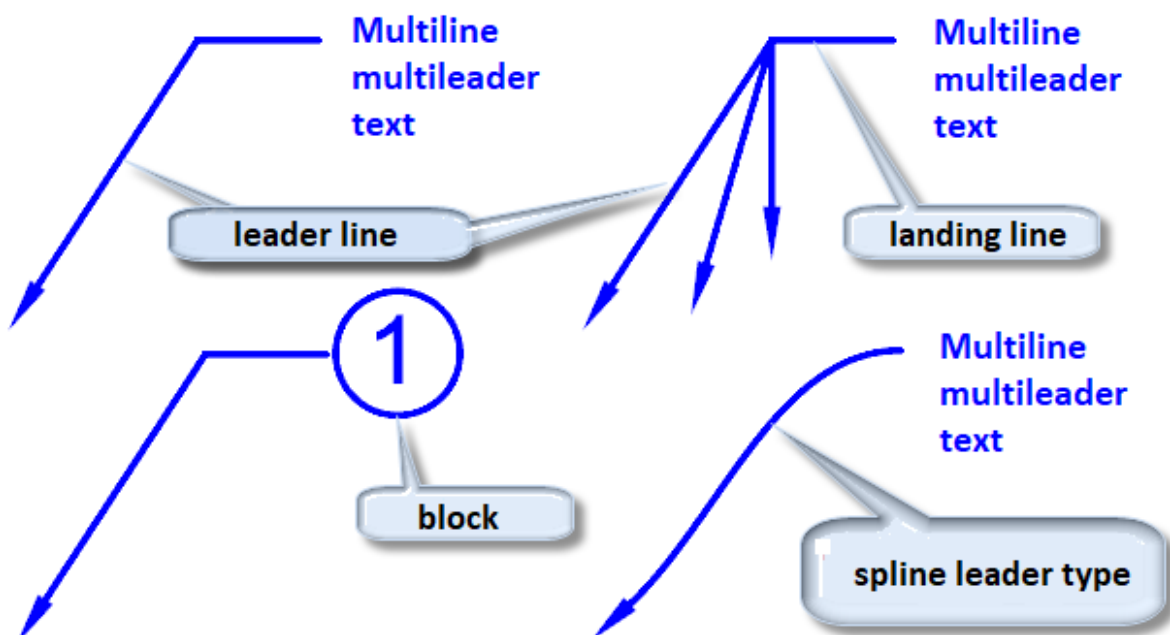

The visual representation of a multileader, as well as its other parameters, can be edited when it is being created or on the **Properties** functional panel. For example, it is possible to show or hide a landing, leader lines, change the arrowhead appearance, create a frame around the text, change the point of block attachment, edit parameters of multiline text, incl. [set background mask](#), etc.

It is convenient to adjust the multileader location on the screen with help of functional grips.

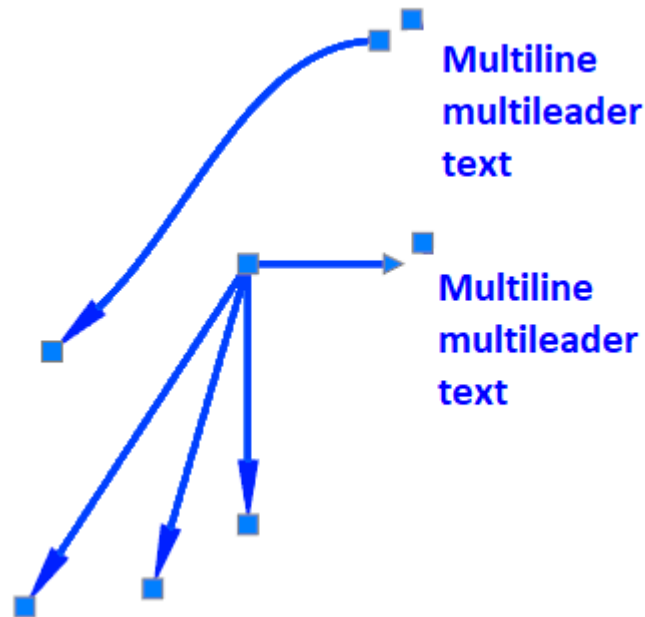

### Command options:

<u>Leader landing first</u>	Start constructing with specifying the location of the multileader landing.
<u>Content first</u>	Start constructing with specifying the location and entry of the text or specifying the block (depending on the type of multileader content specified in the options).
<u>Leader arrowhead first</u>	Start constructing with specifying the location of leader line arrowhead.
<u>Options</u>	Additional options for constructing the multileader.
<u>Leader type</u>	Specify the leader line type: straight, spline or not display the leader line.
<u>Leader landing</u>	Specify whether to display the multileader landing and the landing line size.
<u>Content type</u>	Specify the content type of the multileader being created: block, multiple text or no content.
<u>Maxpoints</u>	Number of points for the leader line. By default 2, i.e. one leader line segment is created.

### Command prompts:





Specify the location of leader arrowhead or [leader landing first /Content first/Options]<leader landing first>:

Query for the location of the arrowhead or the content, depending on the selected order of multileader construction. Additional options can be adjusted by selecting **Options**.

Define the option or [Leader type/Leader landing/Content type/Maxpoints/First angle/Second angle/Exit options]<exit options>:







Displayed when **Options** is selected in the previous query.

## Removing Leader Lines from the Multileader

-  Ribbon: **Home, Annotate – Leaders –**  **Multileader Edit Remove**
-  Menu: **Modify – Object – Multileader >**  **Remove Multileader**
-  Toolbar: **Mleaders –** 
-  Command line: **MLEADEREDITREMOVE**

To remove a leader line, it is necessary to select it on the multileader object in the drawing. The leader line is deleted immediately after its selection.







## Adding Leader Lines to the Multileader

-  Ribbon: **Home, Annotate – Leaders –**  **Multileader Edit Add**
-  Menu: **Modify – Object – Multileader >**  **Add Multileader**
-  Toolbar: **Mleaders –** 
-  Command line: **MLEADEREDITADD**

### To add a leader line:

1. Select the desired multileader in the workspace.
2. Specify the point of arrowhead location for each added leader line.
3. Press **ENTER** to finish.

## Aligning Multileaders

-  Ribbon: **Home, Annotate – Leaders –**  **Multileader Align**
-  Menu: **Modify – Object – Multileader >**  **Align**
-  Toolbar: **Mleaders –** 
-  Command line: **MLEADERALIGN**

Aligns the selected leaders and spaces them at equal intervals in accordance with the preset options.

### Command options:

#### Options

Specifies options for spacing and aligning the selected multileaders. The command memorizes and by default uses the align method specified last time.

#### Distribute

The leaders landings with the content will be evenly distributed between two points specified on the screen.

Make leader segments parallel

Places content so that last leader lines segments in the selected multileaders become parallel.

Specify spacing

Specifies the value of spacing between landing lines for the selected multileaders.

Use current spacing

Uses the current spacings inside the content of multileaders.

**Command prompts:**

Select multileaders or [?]:

Specify the multileaders to be aligned or distributed depending on the operation selected in the command options.

Select multileader to align or [?/Options]:

Select the leader on which the rest should be aligned. The query is displayed in the beginning of the align operation. The type of alignment operation is preset in the command options (**Options** option).

## Collecting Multileaders

 Ribbon: **Home, Annotate – Leaders –  Multileader Collect**

 Menu: **Modify – Object – Multileader >  Collect**

 Toolbar: **Mleaders – **

 Command line: **MLEADERCOLLECT**

Collecting several multileaders containing blocks in one with horizontal or vertical location of blocks.

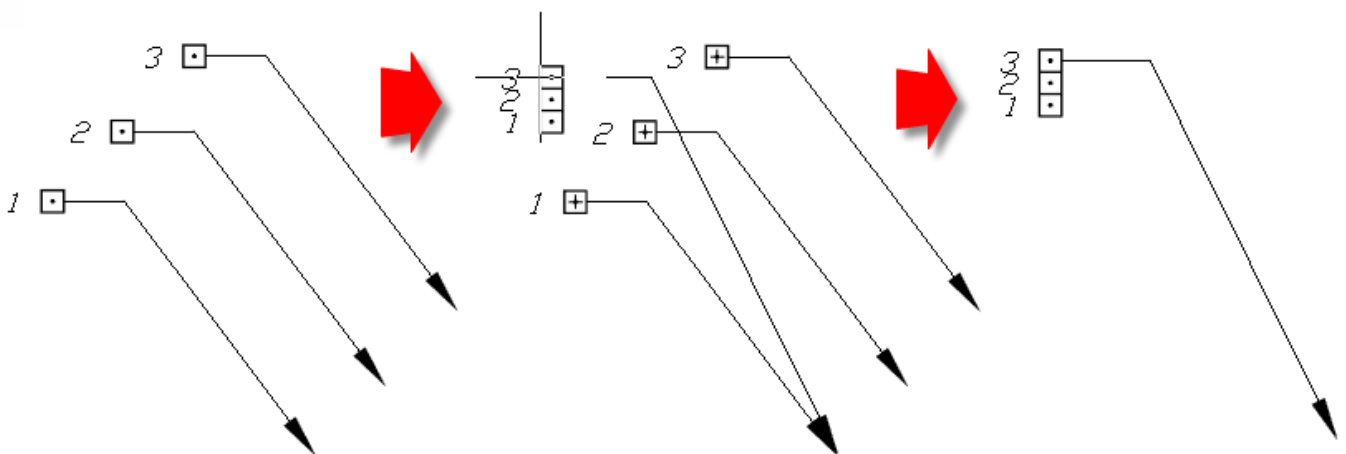



### Command options:

<u>Vertical</u>	Specifies options for spacing and aligning the selected multileaders. The command memorizes and by default uses the align method specified last time.
<u>Horizontal</u>	Leader landings with the content will be evenly distributed between two points specified on the screen.
<u>Wrap</u>	Specifies a width value for a wrapped multileader collection.
<u>Specify wrap width</u>	Wrap width.
<u>Number</u>	Maximum number of blocks per row in the multileader collection.

### Command prompts:

Select multileaders or [?]:	Specify the multileaders to be collected. Multileaders without blocks will be excluded from the selection. The blocks will be placed in the order of selecting multileaders. An extension line of the last selected leader will be saved.
Specify the position of collected multileader or [ <u>Vertical/Horizontal/Wrap</u> ] <u>&lt;Vertical&gt;</u> :	Select the method to collect multileaders (horizontal or vertical) and specify the location of its content in the drawing workspace.

## Multileader Style Manager

 Ribbon: **Home, Annotate – Leaders** – 

 Toolbar: **Mleaders** – 

 Command line: **MLEADERSTYLE**

The command opens the **Multileader Style Manager** dialog box, where it is possible to create and modify the multileader styles.

Multileaders are created with the style displayed in the drop-down list on the **Mleaders** panel or on the ribbon in the **Draw** tab in the **Leaders** group.

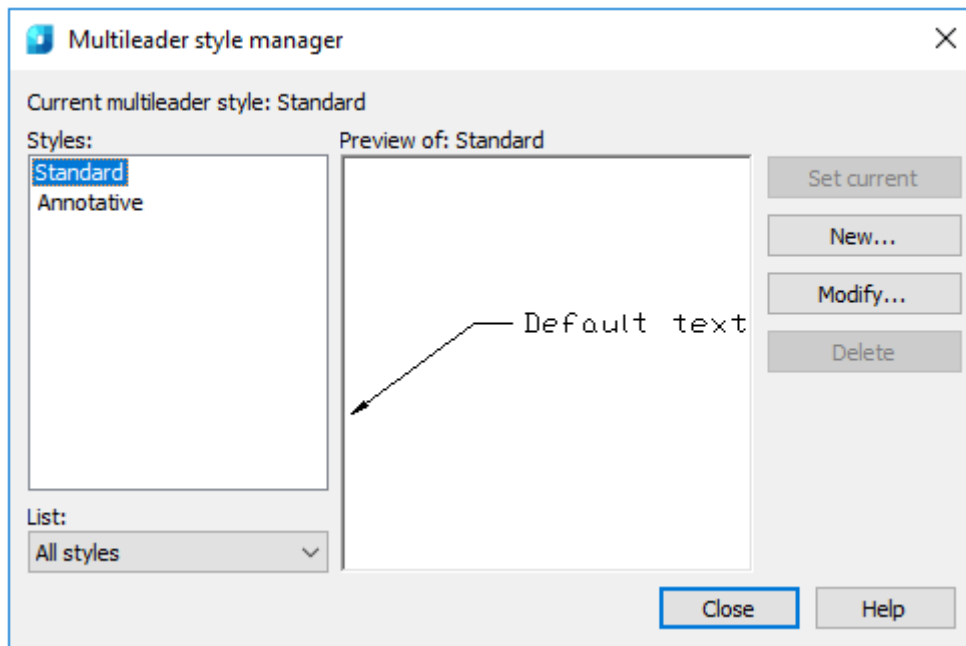

**Options:**

- Styles** List of multileader styles in the document. Its content is regulated by the **List** drop-down list.
- List** Specifies what styles should be displayed in the **Styles** list: all document styles or only current ones.
- Preview of** A preview window that displays the assumable image of the multileader created with use of style selected in the **Styles** list.
- Set current** Makes current the style selected in the **Styles** field.
- New** Opens the **Create New Multileader Style** dialog box to create a new style based on that selected in the **Styles** field.

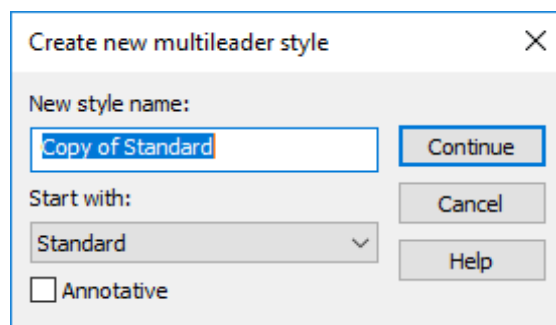

Clicking of the **Continue** button opens the **Modify Multileader Style** dialog box described below.

- Modify** Opens the **Modify Multileader Style** dialog box to edit the style selected in the **Styles** field.
- Delete** Deletes the style selected in the **Styles** field.

A context menu is also available in the **Styles** field. In addition to the listed actions, there it is possible to rename the selected style:

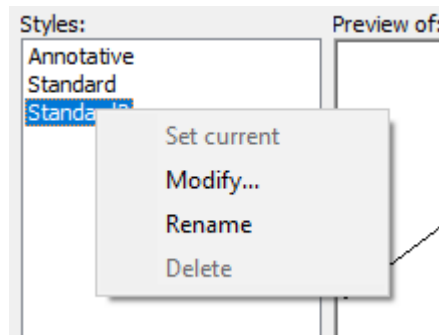

## Modifying Multileader Style

The **Modify Multileader Style** dialog box opens when you edit the current or create a new style.

In the left part the dialog contains three tabs with adjustable parameters, and in the right one – the preview area displaying the multileader in accordance with the current options.

### Leader Format tab

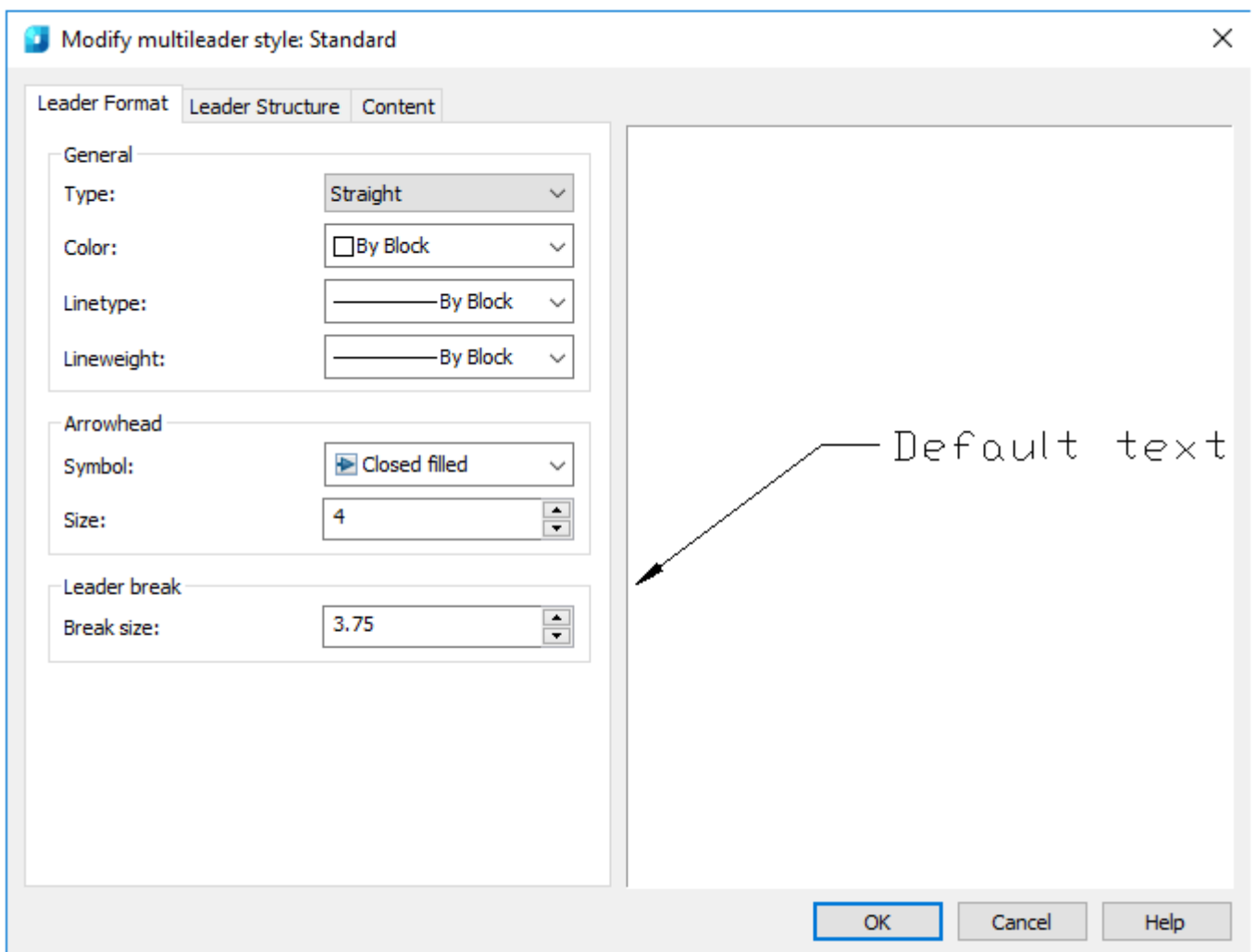

### Options:

#### General

- Type** Type of multileader line landing – straight, spline or no leader line.
- Color** Drop-down list to select the multileader color.

**Linetype**

Drop-down list to select the typeline of the leader line.

**Lineweight**

Drop-down list to select the lineweight of the leader line.

*Arrowhead*

**Symbol**

The arrowhead symbol.

**Size**

The arrowhead size.

*Leader break*

**Break size**

Break size of the multileader.

*Leader Structure tab*

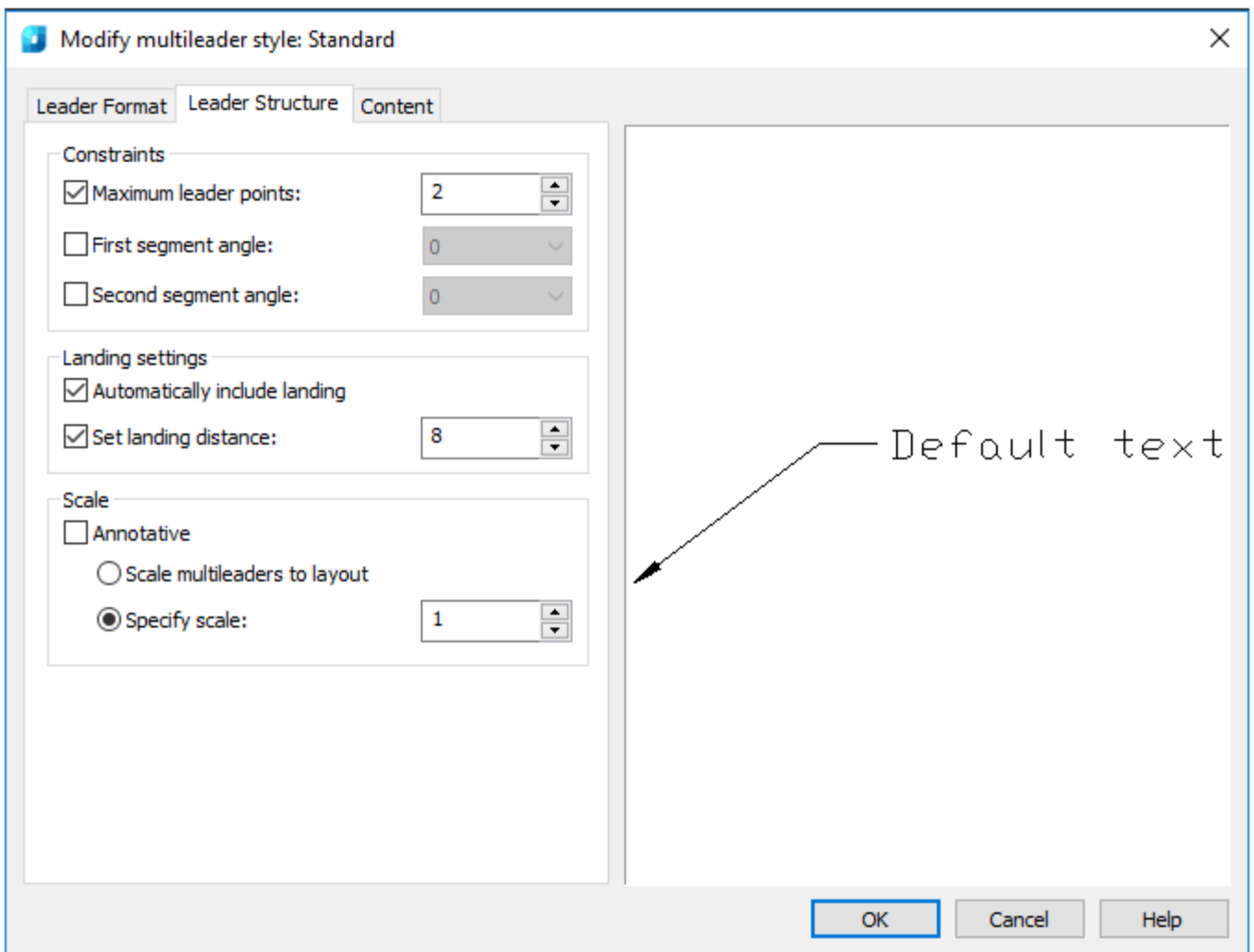

**Options:**

*Constraints*

**Maximum leader points**

A leader point can have more than one segment and be similar to a jogged polyline. The option specifies the number of points for the leader line, which will be requested when constructing a multileader.

**First segment angle**

Specifies the angle of the first segment in the leader line.

**Second segment angle**

Specifies the angle of the second segment in the leader line.

### Landing settings

**Automatically include landing**

Automatic addition of the landing when creating a multileader. If the option is disabled, the landing will not be added.

**Set landing distance**

Determines the fixed distance for the multileader landing line.

### Scale

**Annotative**

Annotation of multileader. It is not used in the current program version. The option allows you to correct the object automatically for similar display in one and the same size or scale irrespective of the type scale.

**Scale multileaders to layout**

Scales the multileader in accordance with the current layout.

**Specify scale**

Specifies the scale of multileader.

### Content tab

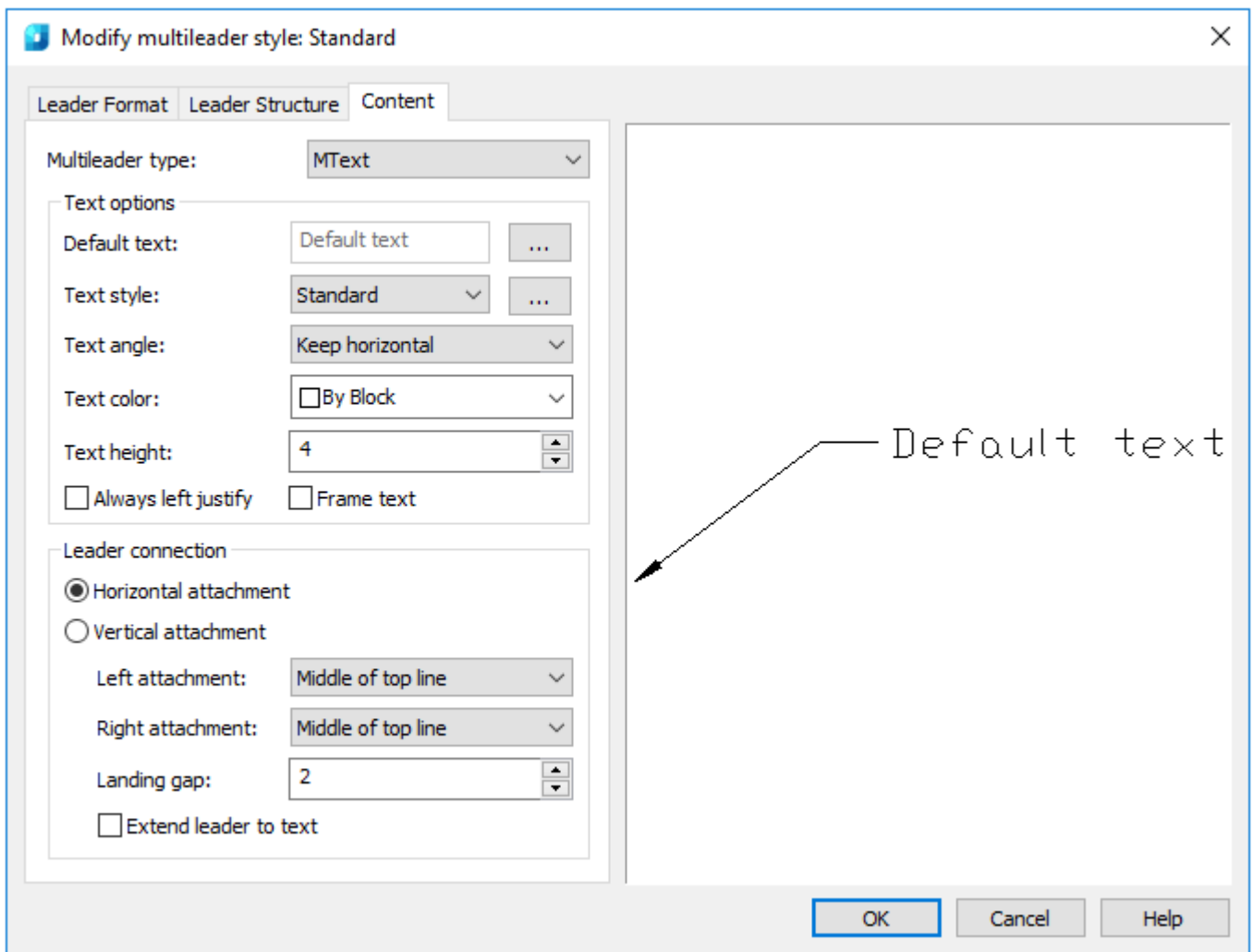

### Options:

**Multileader type**

Type of the multileader content: multiline text, attached block or no content.

### Text options







<b>Default text</b>	Sets default text for the multileader. When creating a multileader it is possible to select: whether to leave the default text or enter the other one.
<b>Text style</b>	Predefined text style for the text. Displays the text styles downloaded as of the moment.
<b>Text line angle</b>	Specifies the rotation angle of the multileader text.
<b>Text color</b>	Specifies the color of the multileader text.
<b>Text height</b>	Specifies the height of the text.
<b>Always left justify</b>	Specifies that the text is left justified.
<b>Frame text</b>	Frames the text content of the multileader.

### Leader connection

<b>Horizontal attachment</b>	Specifies the landing horizontal attachment to the content.
<b>Vertical attachment</b>	Specifies the vertical landing attachment to the content.
<b>Left/Top Attachment</b>	Specifies the method of left or top attachment (depending on the attachment option selected above).
<b>Right/Bottom Attachment</b>	Specifies the method of right or bottom attachment (depending on the attachment option selected above).
<b>Landing gap</b>	Specifies the distance between the content and the landing.
<b>Extend leader to text</b>	Available only in case of selecting the horizontal attachment.

## Notes

### Mechanical Note



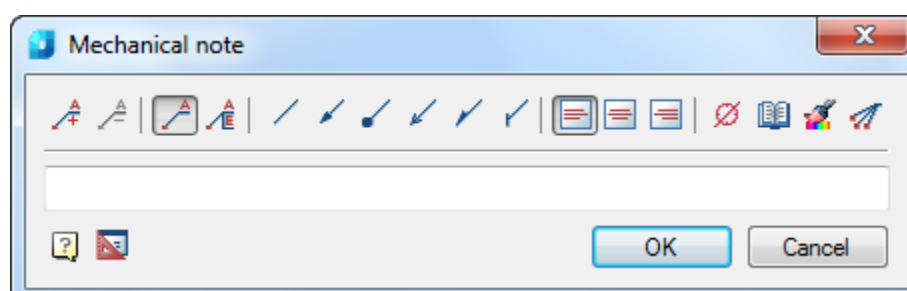

-  Ribbon: **Home, Annotate – Leaders –  Mechanical notes**
-  Menu: **Draw – Notes >  Mechanical notes...**
-  Toolbar: **Utilities – **
-  Command line: **NOTE**

This command opens the **Mechanical note** dialog box to set the mechanical note options:









### Options:



Use the icons to add/remove text input fields and to add a border:

-  Add string.
-  Remove string.
-  Simple note.
-  Multiline note.





Use the icons to select the style of the extension line:

-  None.
-  Arrow.
-  Point.
-  Open arrow.
-  Half-arrow.
-  Oblique.

Use the icons to select the text alignment method:

-  By left edge.
-  By center.
-  By right edge.

Other icons and options:

-  The **Insert special symbol** icon opens the panel with the table of special symbols, to select and insert them at the current cursor position in the text input field.
-  The **Notepad** icon opens the **Notepad** dialog box.
-  The **Match properties** icon temporarily closes the dialog box to specify the inserted leader whose properties should be copied and applied to the newly-created leader.
-  The **Add extension line** icon is used to insert additional extension lines. The icon is enabled when you edit a leader inserted into the drawing.

Right-click in the text field and choose the required menu item:

History	>
Recent	>
Template	>
Not defined	
Add string	Ctrl+Enter
Remove string	Ctrl+Del
Superscript	Ctrl+Up
Subscript	Ctrl+Down
Insert division	
Fraction text size	>
Insert big brackets	
Pick text from drawing	Ctrl+T
Pick from drawing	Ctrl+B
Insert object...	
Create hyperlink...	
Insert field...	
Symbols	>
Undo	Ctrl+Z
Cut	Ctrl+X
Copy	Ctrl+C
Paste	Ctrl+V
Delete	Del
Select all	Ctrl+A

The **History** item contains a list of recently input text lines.

The **Recent** item is a list specified by the user. Upon typing the desired leader text, you can add it to the list of frequently used ones for quick reference later.

**Template** – connects templates.

**Add string** – adds a line to the leader text (a field for a new line appears in the dialog box).

**Remove string** – removes a line.

**Superscript** – inserts a superscript.

**Subscript** – inserts a subscript.

**Insert division** – inserts fractional text.

**Fraction text size** – selects a fraction dimension option from the list:: **Default, Like the main text, One step less.**

**Insert big brackets** – inserts parenthesis.

**Pick text from drawing** – inserts the text specified in the drawing into the field. If you change the original text, the universal leader text will update automatically.

**Pick from drawing** – allows you to select text or value in the current drawing.

**Insert object...** – inserts a drawing object instead of the leader text.



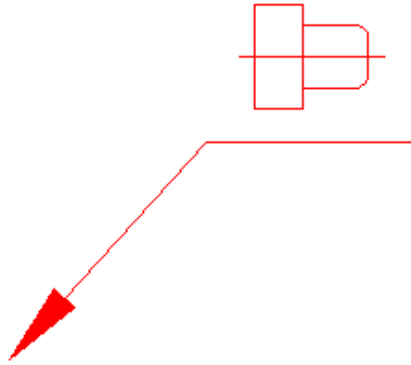

**Create hyperlink...** – creates a hyperlink.

**Insert field...** – inserts a field (FIELD command).

**Symbols** – inserts a standard symbol (degree, slope, etc.) or any symbol from the OS symbol table.

**Undo** – undoes the last action.

**Cut, Copy, Paste** – standard operations using the OS clipboard.

**Delete** – deletes text from the input field.

**Select all** – selects all text in the input field (for example, for replacement).

The **Pick from drawing** item opens the **Value picker** toolbar which allows you to copy values from the objects on the drawing:

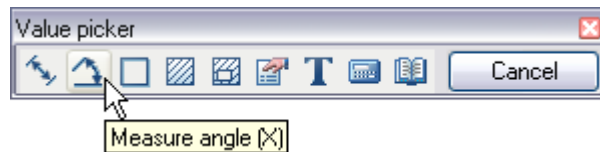



 **Measure distance (Z)** – take a linear or diametrical geometric dimension from the drawing. The command can be started by pressing the **Z** key.

 **Measure angle (X)** – take an angular dimension from the drawing. The command can be started by pressing the **X** key.

 **Measure perimeter (C)** – take the value of a closed line perimeter or the length of a broken line from the drawing. The command can be started by pressing the **C** key.

 **Measure area (V)** – take the value of the closed contour area from the drawing. The command can be started by pressing the **V** key.

 **Complex area (Shift+V)** – take the value of several closed contour areas in the drawing.

 **Take from property (B)** – take the parameter values of a standard nanoCAD database part. The parameter is inserted with maintaining the dynamic connection with the object. When you change a part parameter, the line in the input field changes.

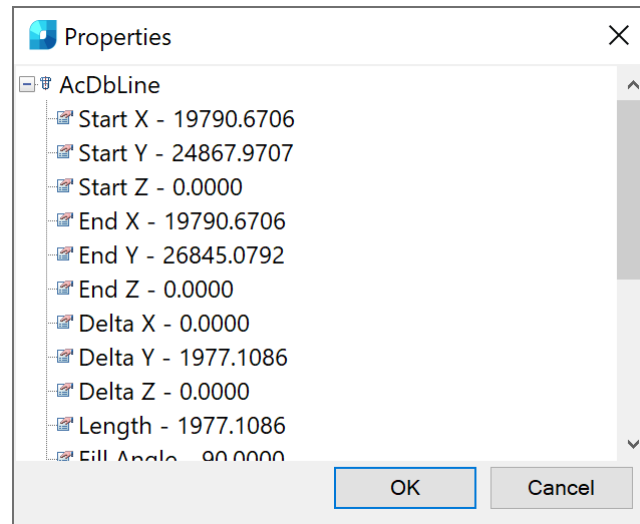

**NOTE** To insert static text, hold **CTRL** while selecting a parameter.

**T** **Take from text (N)** – take text from a drawing object.

 **Calculate (M)** – calculate a numerical value using the built-in nanoCAD.

 **Take from notes (,)** – insert text information from a notepad.

**Cancel** – rejecting the command and returning to the previous menu.

**To create a mechanical note:**

1. Type the required text into the text fields.
2. Select the required leader options.
3. Click **OK**.
4. Specify a point on the object to which the leader arrow will be directed.

The following arrow type switching options are available in the command line and context menu:

None – Creates the extension line without an arrow.

Arrow – Creates the extension line with an arrow.

Point – Creates the extension line with a point.

5. Select an option and specify the leader position on the drawing.

## Construction Note



Ribbon: **Home, Annotate – Leaders >**  **Construction note**



Menu: **Draw – Notes >**  **Construction notes...**



Toolbar: **Utilities –** 



Command line: **NOTEP**

This command opens the **Construction note** dialog box to set the note options:

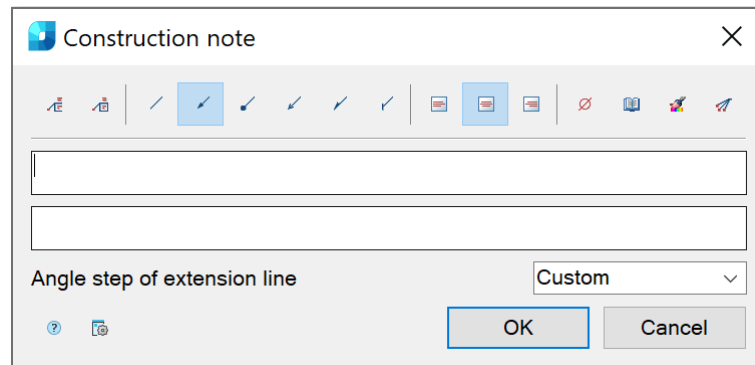

### Options:

#### Buttons to add borders:



Managing multiline text output above the leader.



Framing the text under the leader.

#### Use the icons to select the style of the extension line:



None.



Arrow.



Point.



Open arrow.



Half-arrow.



Oblique.

#### Use the icons to select the text alignment method:



By left edge.



By center.



By right edge.

#### Other icons and options:



The **Insert special symbol** icon opens the panel with the table of special symbols, to select and insert them at the current cursor position in the text input field.



The **Notepad** icon opens the **Notepad** dialog box.



The **Match properties** icon temporarily closes the dialog box to specify the inserted leader whose properties should be copied and applied to the newly-created leader.



The **Add extension line** icon is used to insert additional extension lines. The icon is enabled when you edit a leader inserted into the drawing.

**Angle step of extension line**

Drop-down list to select inclination.

In the list the following inclinations are available:

- **Custom** - the extension line is placed arbitrarily (by default);
- **15** - the extension line is placed in step multiples of 15°;
- **30** - the extension line is placed in step multiples of 30°;
- **45** - the extension line is placed in step multiples of 45°;
- **90** - the extension line is placed in step multiples of 90°.



The Options button opens the nanoCAD Design Settings dialog box – Symbols tab.

Right-click in the text field and choose the required menu item:

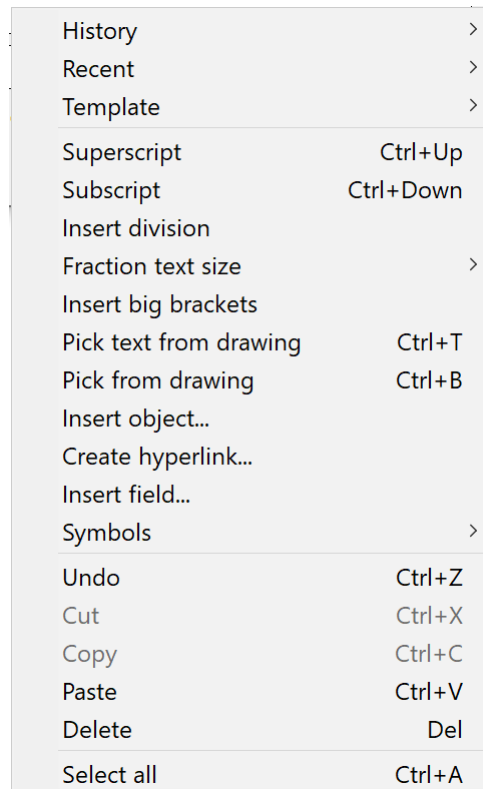



For more information about additional commands, see the [Mechanical Note](#) section.

**To create a construction note:**

1. Type the required text into the text fields.
2. Select the required note options.
3. Click **OK**.
4. Specify a point on the object to which the leader arrow will be directed.
5. Specify the shelf position on the drawing.

## Comb Leader Note

-  Ribbon: **Home, Annotate – Leaders >**  **Comb Leader note**
-  Menu: **Draw – Notes >**  **Comb leader notes...**
-  Toolbar: **Utilities –** 



Command line: **NOTE**

This command opens the **Comb leader note** dialog box to set the comb leader note options:

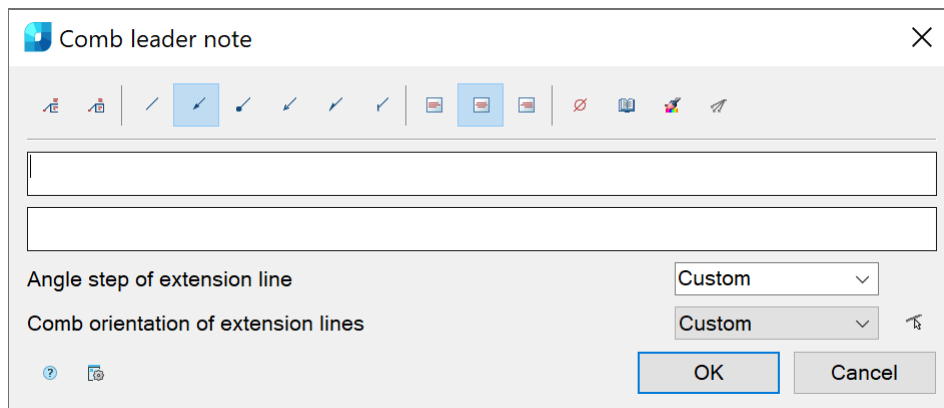

### Options:

#### Buttons to add borders:



Managing multiline text output above the leader.



Framing the text under the leader.

#### Use the icons to select the style of the extension line:



None.



Arrow.



Point.



Open arrow.



Half-arrow.



Oblique.

#### Use the icons to select the text alignment method:



By left edge.



By center.



By right edge.

#### Other icons and options:



The **Insert special symbol** icon opens the panel with the table of special symbols, to select and insert them at the current cursor position in the text input field.



The **Notepad** icon opens the **Notepad** dialog box.



The **Match properties** icon temporarily closes the dialog box to specify the inserted leader whose properties should be copied and applied to the newly-created leader.



The **Add extension line** icon is used to insert additional extension lines. The icon is enabled when you edit a leader inserted into the drawing.



The **Select line** icon is used to switch the comb orientation parallel to the specified line on the drawing. The icon is available when you edit the comb leader note inserted into the drawing.

**Angle step of extension lines:**

Drop-down list to select inclination.

In the list the following inclinations are available:

- **Custom** - the extension line is placed arbitrarily (by default);
- **15** - the extension line is placed in step multiples of 15°;
- **30** - the extension line is placed in step multiples of 30°;
- **45** - the extension line is placed in step multiples of 45°;
- **90** - the extension line is placed in step multiples of 90°.

**Comb orientation of extension lines:**

Drop-down list to select the comb orientation of the extension line.

The following options are available in the list:

- Custom
- Horizontal
- Vertical



The Options button opens the nanoCAD Design Settings dialog box – Symbols tab.

Right-click in the text field and choose the required menu item:

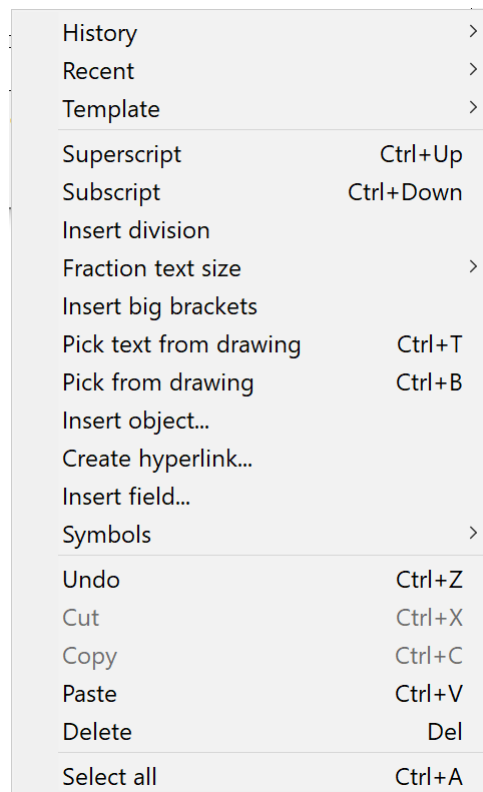

For more information about additional commands, see the [Mechanical Note](#) section.

**To create a comb leader note:**

1. Type the required text into the text fields.
2. Select the required leader options.
3. Click **OK**.
4. Specify the leader's position and press **ENTER** to end.
5. Specify the leader's position and angle. In the command line the following prompts are displayed: [Horizontal /Vertical /Parallel]. The Parallel option allows you to choose the direction of a comb leader note parallel to any line on the drawing.

6. Specify the shelf position on the drawing.

## Section Note



Ribbon: **Home, Annotate – Leaders** >  **Section note**



Menu: **Draw – Notes** >  **Section notes...**



Toolbar: **Utilities** – 



Command line: **NOTES**

This command opens the **Section note** dialog box to set the note options:

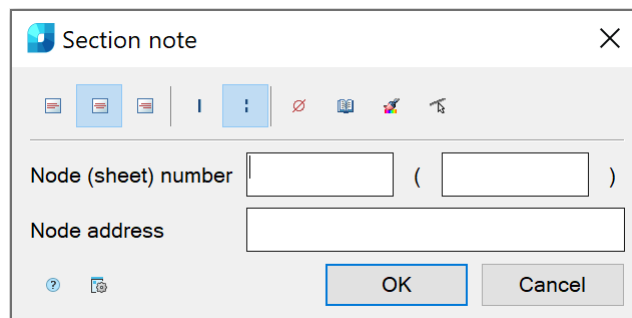

### Options:

Use the icons to select the text alignment method:



By left edge.



By center.



By right edge.

Use the icons to select the secant type:



Single-stroked line.



Double-stroked line.

Other icons:



The **Insert special symbol** icon opens the panel with the table of special symbols, to select and insert them at the current cursor position in the text input field.



The **Notepad** icon opens the **Notepad** dialog box.



The **Match properties** icon temporarily closes the dialog box to specify the inserted leader whose properties should be copied and applied to the newly-created leader.



The **Select line** icon is used to override the first and second lines of breaking construction. The icon is available when you edit the node secant note inserted into the drawing.

Node  
(sheet)  
number

An input line consisting of two fields to indicate the Node and Sheet number.

Node  
address

Input line to specify the Node Address.



The Options button opens the nanoCAD Design Settings dialog box – Symbols tab

Right-click in the text field and choose the required menu item:

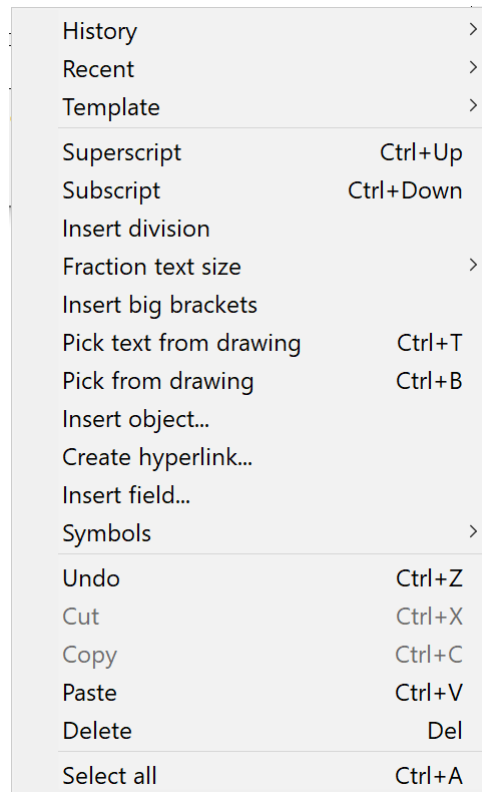

For more information about additional commands, see the [Mechanical Note](#) section.

**To create a section note:**

1. Type the required text into the text fields.
2. Select the required note options.
3. Click **OK**.
4. Specify the first line of breaking construction, perpendicular to which the secant line will be located.
5. Specify the second line of breaking construction.
6. Specify the shelf position on the drawing.

## Note for Multilayered Constructions



Ribbon: **Home, Annotate – Leaders >**  **Multilayered construction note**



Menu: **Draw – Notes >**  **Notes for multilayered designs...**



Toolbar: **Utilities –** 



Command line: **NOTEM**





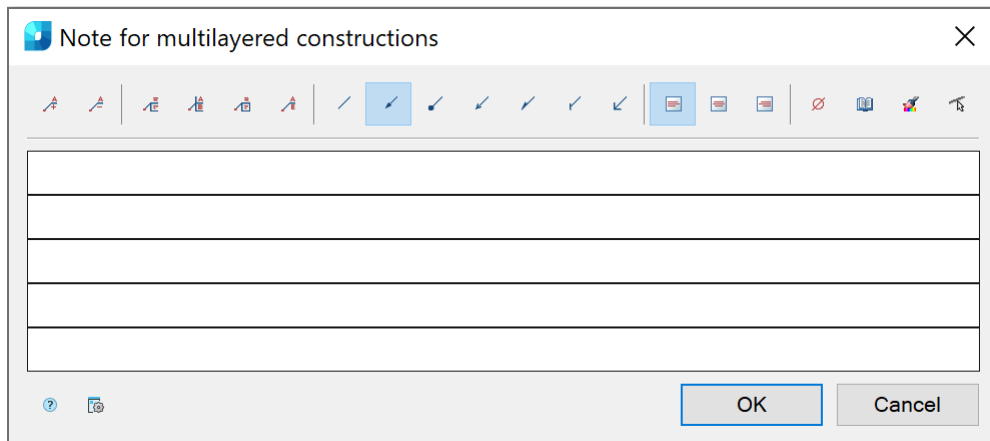

This command opens the **Note for multilayered constructions** dialog box to set the note options:











### Options:



Use the icons to add/remove text input fields and to add border:

-  Add string.
-  Remove string.
-  Managing multiline text output above the leader.
-  Line on first string.
-  Framing the text under the leader.
-  Managing output in a multiline note of the last line without the leader.



Use the icons to select the style of the extension line:

-  None.
-  Arrow.
-  Point.
-  Open arrow.
-  Half-arrow.
-  Oblique.
-  Right angle.

Use the icons to select the text alignment method:

-  By left edge.
-  By center.
-  By right edge.

Other icons:

-  The **Insert special symbol** icon opens the panel with the table of special symbols, to select and insert them at the current cursor position in the text input field.
-  The **Notepad** icon opens the **Notepad** dialog box.



The **Match properties** icon temporarily closes the dialog box to specify the inserted leader whose properties should be copied and applied to the newly-created leader.



The **Select line** icon is used to switch the comb orientation parallel to the specified line on the drawing. The icon is available when you edit the comb leader note inserted into the drawing.



The Options button opens the nanoCAD Design Settings dialog box – Symbols tab

Right-click in the text field and choose the required menu item:

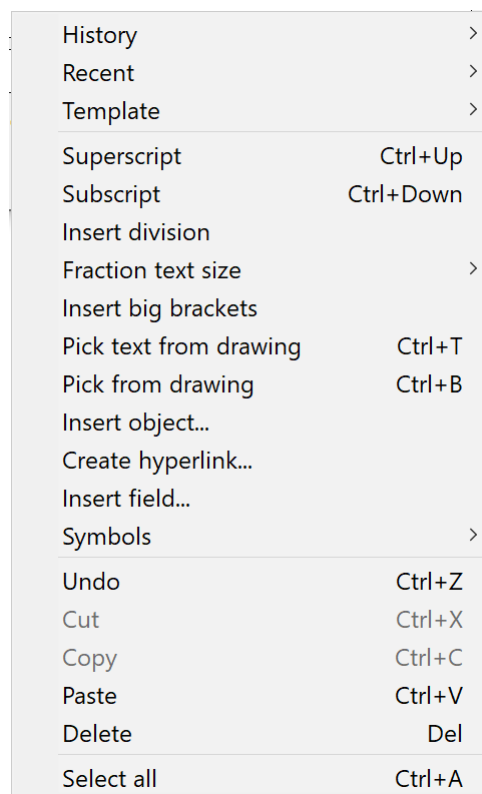

For more information about additional commands, see the [Mechanical Note](#) section.

**To create a note for multilayer constructions:**

1. Type the required text into the text fields.
2. Select the required note options.
3. Click **OK**.
4. Specify a point on the object to which the leader arrow will be directed.
5. Specify the shelf position on the drawing.

## Node Note



Ribbon: **Home, Annotate – Leaders** >  **Node note**



Menu: **Draw – Notes** >  **Node notes...**



Toolbar: **Utilities** – 



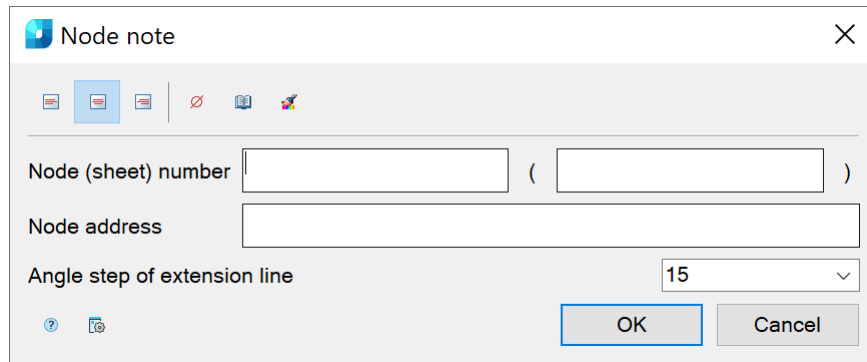

Command line: **NLD, NLEADER, NOTEK**

This command opens the **Node note** dialog box to set the note options:



### Options:

Use the icons to select the text alignment method:

-  By left edge.
-  By center.
-  By right edge.

Other icons and options:

 The **Insert special symbol** icon opens the panel with the table of special symbols, to select and insert them at the current cursor position in the text input field.

 The **Notepad** icon opens the **Notepad** dialog box.

 The **Match properties** icon temporarily closes the dialog box to specify the inserted leader whose properties should be copied and applied to the newly-created leader.

**Node (sheet) number** An input line consisting of two fields to indicate the **Node and Sheet number**.

**Node address** Input line to specify the **Node Address**.

**Inclination step of extension lines:** Drop-down list to select the inclination. In the list the following inclinations are available:

- **Custom** - the extension line is placed arbitrarily (by default);
- **15** - the extension line is placed in step multiples of 15°;
- **30** - the extension line is placed in step multiples of 30°;
- **45** - the extension line is placed in step multiples of 45°;
- **90** - the extension line is placed in step multiples of 90°.

 The Options button opens the nanoCAD Design Settings dialog box – Symbols tab

Right-click in the text field and choose the required menu item:

History	>
Recent	>
Template	>
Superscript	Ctrl+Up
Subscript	Ctrl+Down
Insert division	
Fraction text size	>
Insert big brackets	
Pick text from drawing	Ctrl+T
Pick from drawing	Ctrl+B
Insert object...	
Create hyperlink...	
Insert field...	
Symbols	>
Undo	Ctrl+Z
Cut	Ctrl+X
Copy	Ctrl+C
Paste	Ctrl+V
Delete	Del
Select all	Ctrl+A

For more information about additional commands, see the [Mechanical Note](#) section.

**To create a note note:**

1. Type the required text into the text fields.
2. Select the required note options.
3. Click **OK**.
4. Specify the oval/circle center.
5. Specify the oval/circle size.
6. Specify the shelf position and/or the leader pitch angle.

## Linear Aligned Note



Ribbon: **Home, Annotate – Leaders** >  **Linear Aligned note**



Menu: **Draw – Notes** >  **Linear aligned note...**



Toolbar: **Utilities** – 



Command line: **LINM**

This command opens the **Linear aligned note** dialog box to set the note options:

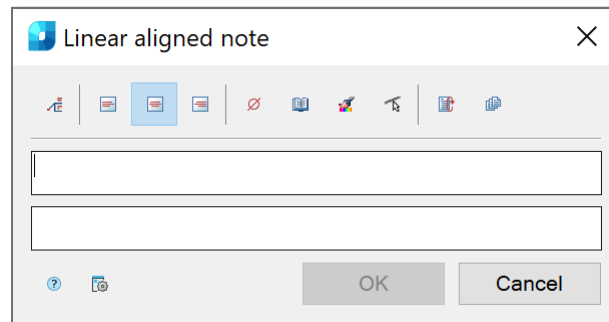

### Options:



Managing multiline text output above the leader.

*Use the icons to select the text alignment method:*



By left edge.



By centre.



By right edge.

*Other icons:*



The **Insert special symbol** icon opens the panel with the table of special symbols, to select and insert them at the current cursor position in the text input field.



The **Notepad** icon opens the **Notepad** dialog box.



The **Match properties** icon temporarily closes the dialog box to specify the inserted leader whose properties should be copied and applied to the newly-created leader.



The **Select line** icon is used to override the insertion place of the extension line. The icon is available when you edit the marks of linear constructions inserted into the drawing.



The **Auto repeat** icon allows you to mark several linear constructions without a repeated command call. For each new leader, the **Linear constructions marking** dialog box will open to set new options for the leader, for example, new text.



The **Multiple insert** icon allows you to mark several linear constructions without a repeated command call. All leaders are drawn with same options and with the same text.



The **Options** button opens the **nanoCAD Design Settings** dialog box – **Symbols tab**.

Right-click in the text field and choose the required menu item:







History	>
Recent	>
Template	>
Superscript	Ctrl+Up
Subscript	Ctrl+Down
Insert division	
Fraction text size	>
Insert big brackets	
Pick text from drawing	Ctrl+T
Pick from drawing	Ctrl+B
Insert object...	
Create hyperlink...	
Insert field...	
Symbols	>
Undo	Ctrl+Z
Cut	Ctrl+X
Copy	Ctrl+C
Paste	Ctrl+V
Delete	Del
Select all	Ctrl+A

For more information about additional commands, see the [Mechanical Note](#) section.

**To create a linear aligned note:**

1. Type the required text into the text fields.
2. Select the required note options.
3. Click **OK**.
4. Select line of construction, on which the mark will be located.
5. Specify the text position.

## Chain Note

-  Ribbon: **Home, Annotate – Leaders >**  **Chain note**
-  Menu: **Draw – Notes >**  **Chain notes...**
-  Toolbar: **Utilities –** 
-  Command line: **NOTEH**

The command opens the **Chain note** dialog box to set the note options:

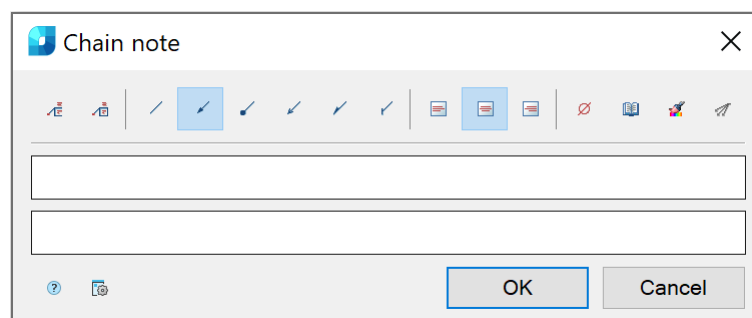

### Options:



Managing multiline text output above the leader.



Framing the text under the leader.

*Use the icons to select the style of the extension line:*



None.



Arrow.



Point.



Open arrow.



Half-arrow.



Oblique.

*Use the icons to select the text alignment method:*



By left edge.



By center.



By right edge.

*Other icons:*



The **Insert special symbol** icon opens the panel with the table of special symbols, to select and insert them at the current cursor position in the text input field.



The **Notepad** icon opens the **Notepad** dialog box.



The **Match properties** icon temporarily closes the dialog box to specify the inserted leader whose properties should be copied and applied to the newly-created leader.



The **Add extension line** icon is used to insert additional extension lines. The icon is available when you edit a chain note inserted into the drawing.

Right-click in the text field and choose the required menu item:

History	>
Recent	>
Template	>
Superscript	Ctrl+Up
Subscript	Ctrl+Down
Insert division	
Fraction text size	>
Insert big brackets	
Pick text from drawing	Ctrl+T
Pick from drawing	Ctrl+B
Insert object...	
Create hyperlink...	
Insert field...	
Symbols	>
Undo	Ctrl+Z
Cut	Ctrl+X
Copy	Ctrl+C
Paste	Ctrl+V
Delete	Del
Select all	Ctrl+A

For more information about additional commands, see the [Mechanical Note](#) section.

**To create a chain note:**

1. Type the required text into the text fields.
2. Select the required note options.
3. Click **OK**.
4. Specify the first leader node.
5. Specify the next leader nodes.
6. Specify the last node and press **ENTER**.
7. Specify the shelf position.

If the first leader node is placed on the line, the extension line will be perpendicular to this line.

## Editing the Leaders

When editing the leaders, the same dialog box as when creating these leaders will be opened, but some additional icons that are blocked when creating leaders will be available (for example, the **Add extension line**, **Select line** and others).

You can open a dialog to edit a leader by:

- placing the mouse cursor over the leader (the leader is highlighted in green) and clicking the right mouse button;
- selecting the leader, clicking the right button and selecting the **Edit** command in the context menu;
- double-clicking the left mouse button on the leader (in the **nanoCAD Design Settings (PARAMS)** dialog on the **Main Options** tab in the **Edit** section – **By Double-click**, the **Program Objects** parameter should be set to **Yes**);
- using the **EDIT** and **FEDIT** commands.

The **In-place edit (IPEDIT)** command or left-clicking on a leader while holding down the **CTRL** key allows you to edit a leader text directly in the drawing.



When you open the context menu on a leader arrow (without highlighting the leader), a dialog box appears to select the type of arrow:



You can also change the arrow type and size in the **Properties** bar:

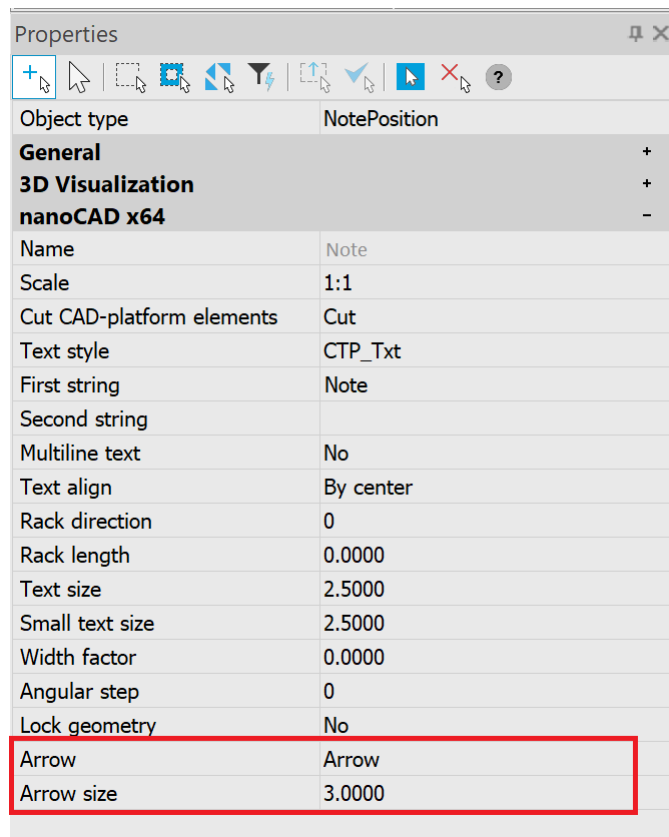

It is very easy to edit leaders with grips (for more information, see **"Advanced grips"**).

You can also detach, append and edit extension lines with the appropriate commands from the **Draw** menu – the **Notes** item or from the **Utilities** toolbar.

## Detach Leader



Ribbon: **Home, Annotate – Leaders** >  **Detach leader**



Menu: **Draw – Notes** >  **Detach leader**



Toolbar: **Utilities** – 



Command line: **PLDELL**

To detach a leader, it is necessary to select it in the drawing. The leader will be detached immediately after its selection.

## Append Leader



Ribbon: **Home, Annotate – Leaders** >  **Append leader**



Menu: **Draw – Notes** >  **Append leader**



Toolbar: **Utilities** – 



Command line: **PLADD**

**To append leader:**

1. Specify a point on the object.
2. If necessary, specify the number of intermediate points forming a break of leader.
3. Specify a point on the required leader inserted in the drawing, to finish the command.

## Edit Leader



Ribbon: **Home, Annotate – Leaders >**  **Edit leader**



Menu: **Draw – Notes >**  **Edit leader**



Toolbar: **Utilities –** 



Command line: **PLREC**

**To edit leader:**

1. Select a leader in the drawing.
2. Specify a point on the required leader to fix a new position for the leader.

## Advanced Grips for Design Elements

Advanced grips are assigned for editing objects on the screen without using the Edit window.

The advanced grips are different in shape (round, triangular, rhombic, etc.) and, in some cases, in color from the ordinary grips.

When the advanced grips operating mode is on, selection of design elements is made first and then they are edited with the mouse.

You can turn the advanced grips operating mode on/off in the **Edit** item in the **Main** tab of the **Design Settings nanoCAD Int** dialog box (the **Tools** menu – the **Advanced Settings** command):

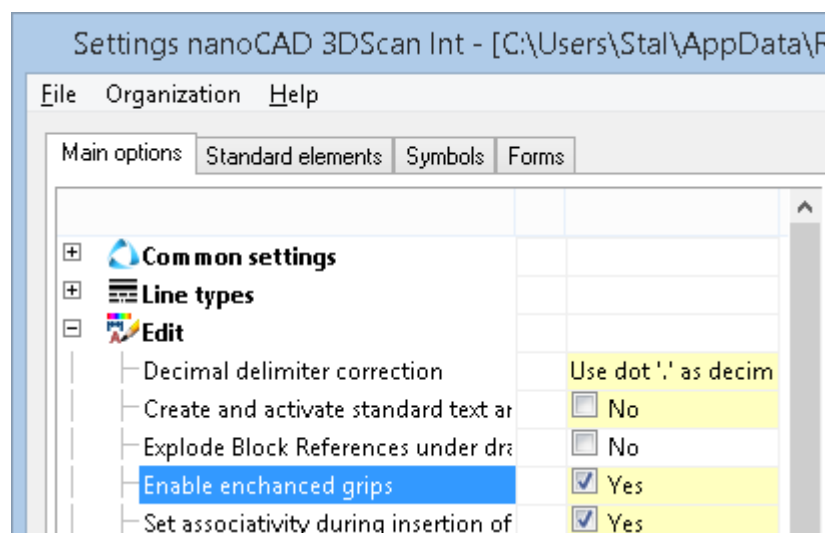

## Mechanical Note

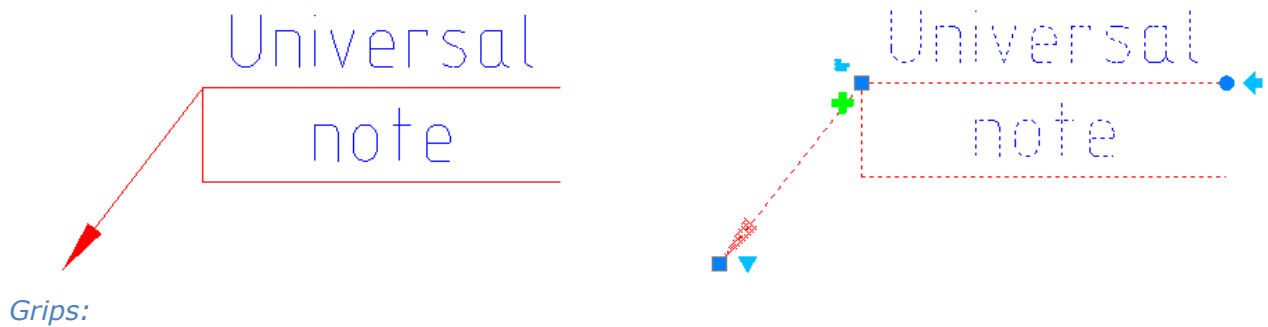

Grips:



Use this grip to select the arrow type.  
Click on the grip to open the menu for arrow type selection:

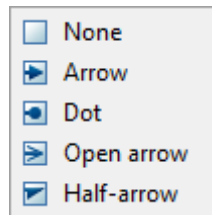

Use this grip to add a leader.



Use this grip to align text.  
There are 3 alignment types:

- by left edge
- by center
- by right edge



Use this grip to rotate a shelf.



Use this grip to mirror a shelf.

## Construction Note

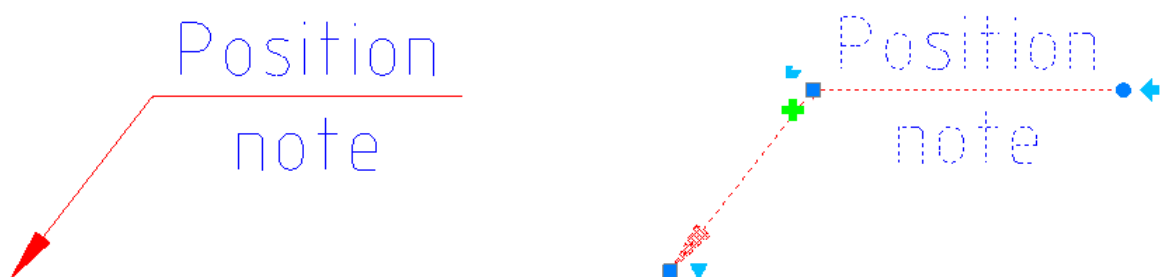

*Grips:*

- ▼ Use this grip to select the arrow type.  
Click on the grip to open the menu for arrow type selection:

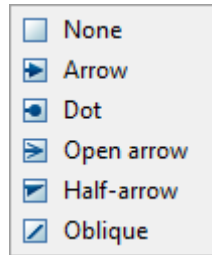

- +
- ≡ Use this grip to align text.  
There are 3 alignment types:
  - by left edge
  - by center
  - by right edge
- Use this grip to rotate a shelf.
- ← Use this grip to mirror a shelf.

### Comb Leader Note

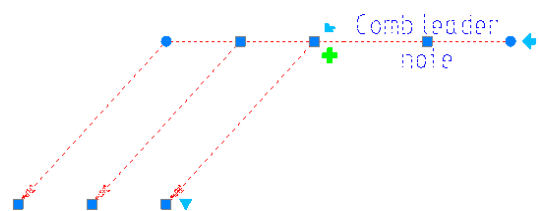
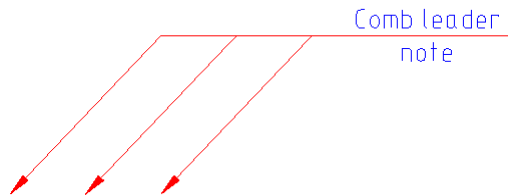

*Grips:*

- ▼ Use this grip to select the arrow type.  
Click on the grip to open the menu for arrow type selection:

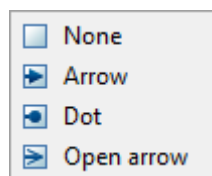

- +
- ≡ Use this grip to align text.  
There are 3 alignment types:
  - by left edge
  - by center
  - by right edge
- Use this grip to rotate a comb line.
- Use this grip to rotate a shelf (located next to the ← grip).

← Use this grip to mirror a shelf.

### Section Note

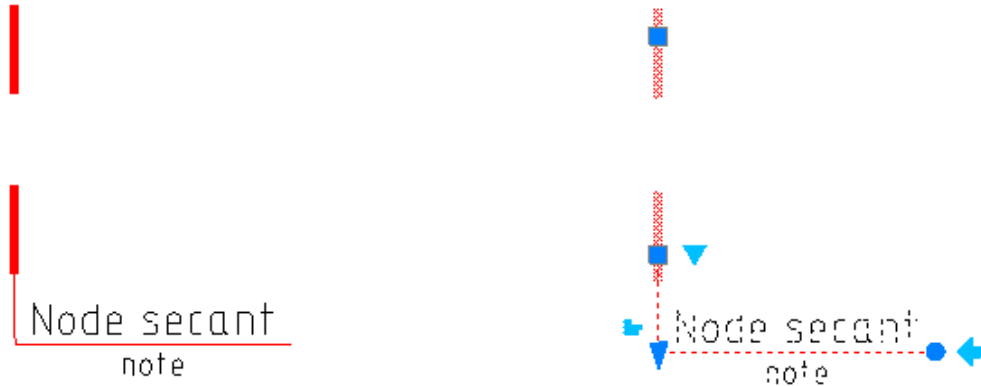

#### Grips:

▼ Use this grip to select the stroke type.  
Click on the grip to open the menu for stroke type selection:

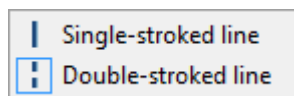

≡ Use this grip to align text.  
There are 3 alignment types:

- by left edge
- by center
- by right edge

● Use this grip to rotate a shelf.

← Use this grip to mirror a shelf.

▼ Use this grip to move a shelf.

### Note for Multilayered Constructions

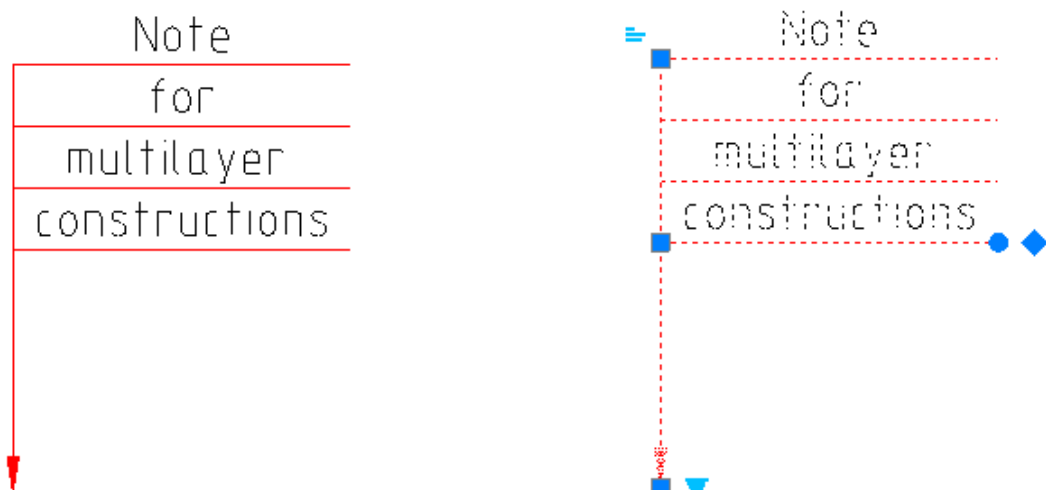

*Grips:*

- ▼ Use this grip to select the arrow type.  
Click on the grip to open the menu for arrow type selection:

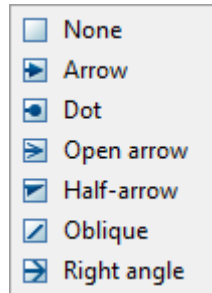

- ≡ Use this grip to align text.  
There are 3 alignment types:
  - by left edge
  - by center
  - by right edge
- Use this grip to rotate shelves.
- ◆ Use this grip to change the position of shelves.

### ***Node Note***





*Grips:*

- ≡ Use this grip to align text.  
There are 3 alignment types:
  - by left edge
  - by center
  - by right edge
- Use this grip to rotate a shelf.
- ← Use this grip to mirror a shelf.

### ***Linear Aligned Note***



*Grips:*

-  Use this grip to align text.  
There are 3 alignment types:
  - by left edge
  - by center
  - by right edge
-  Use this grip to change the shelf position.
-  Use this grip to change the text position.



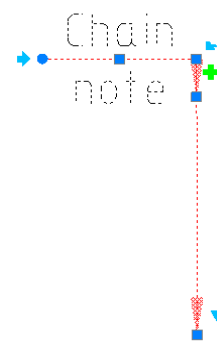
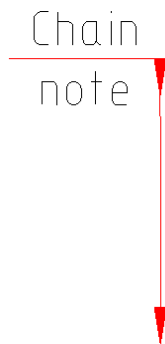

### Chain Note

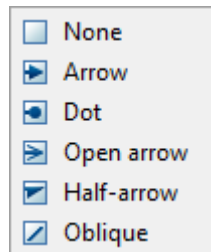

*Grips:*

-  Use this grip to select the arrow type.  
Click on the grip to open the menu for arrow type selection:



-  Use this grip to add a leader.
-  Use this grip to align text.  
There are 3 alignment types:
  - by left edge
  - by center
  - by right edge
-  Use this grip to rotate a shelf.
-  Use this grip to mirror a shelf.

## Table

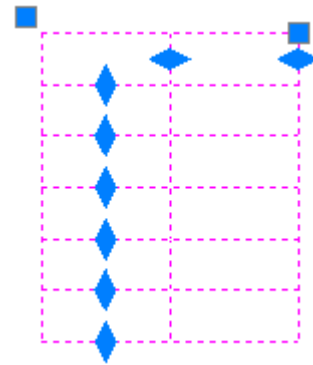
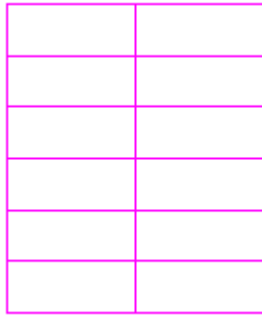

### Grips:



Use these grips to edit the linear dimensions of columns.



Use these grips to edit the linear dimensions of rows.

## Tables



Ribbon: **Annotate – Tables** –  **nanoCAD Tables**



Menu: **Draw – Tables** >  **Tables...**



Toolbar: **Draw** – 



Command line: **TABLE, TB**

The command opens the **Create table** dialog box:



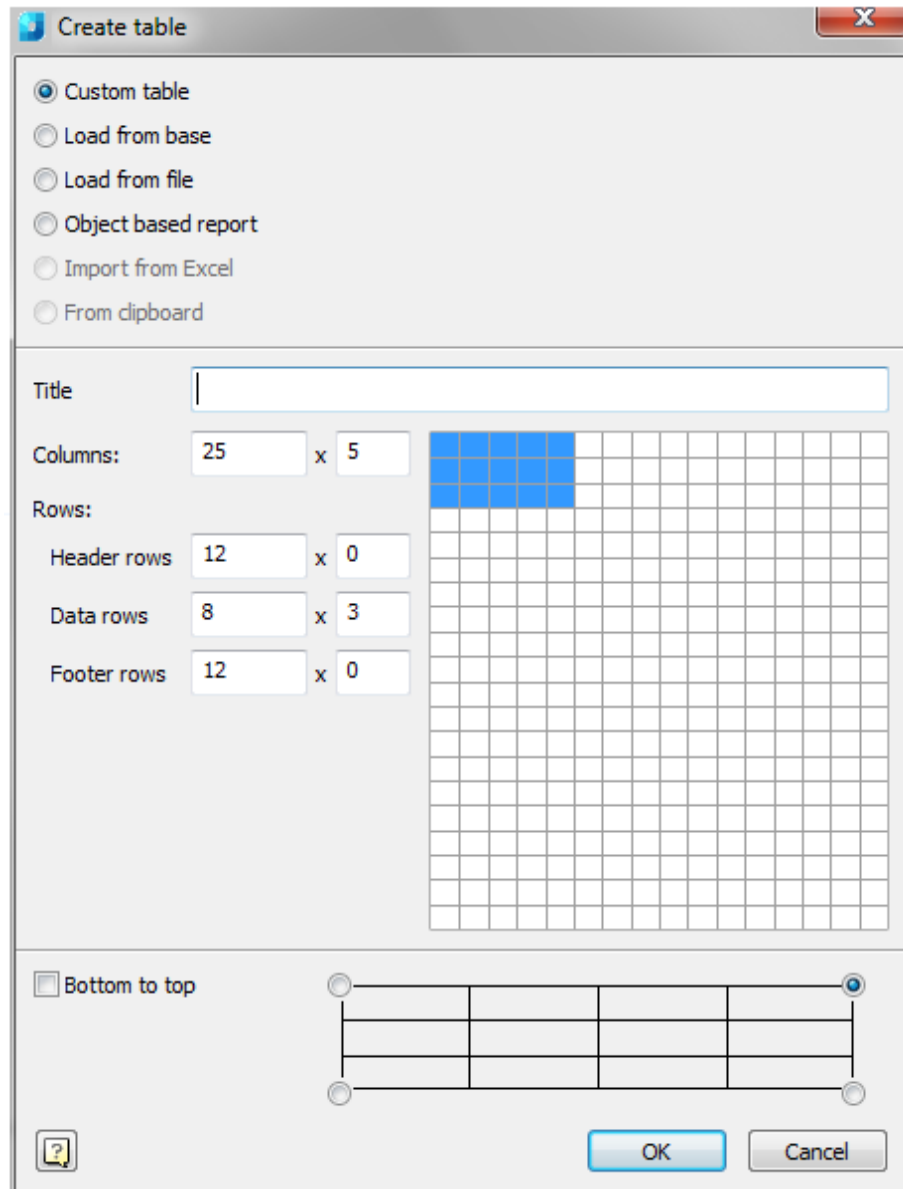

**To create a non-standard table:**

1. Click the **Custom table** item.
2. Use the numeric entry fields to set the parameters for the custom table. The number of rows or columns and cell sizes can be altered later when the table is first edited.

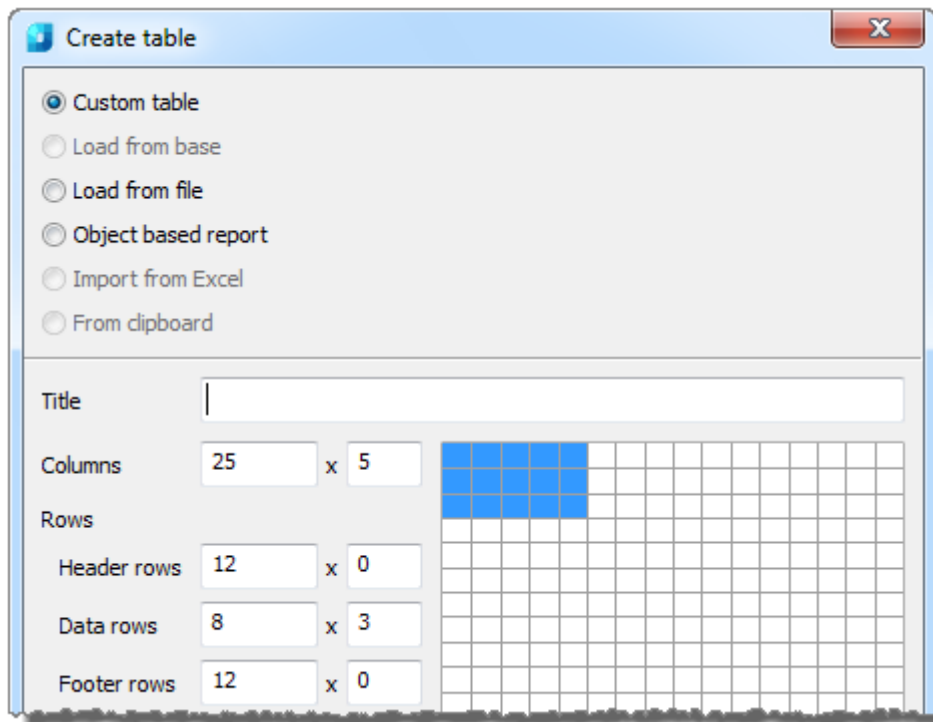

**To insert a standard table:**

1. Click the **Load from base** item.
2. A standard table can be inserted from the nanoCAD library:

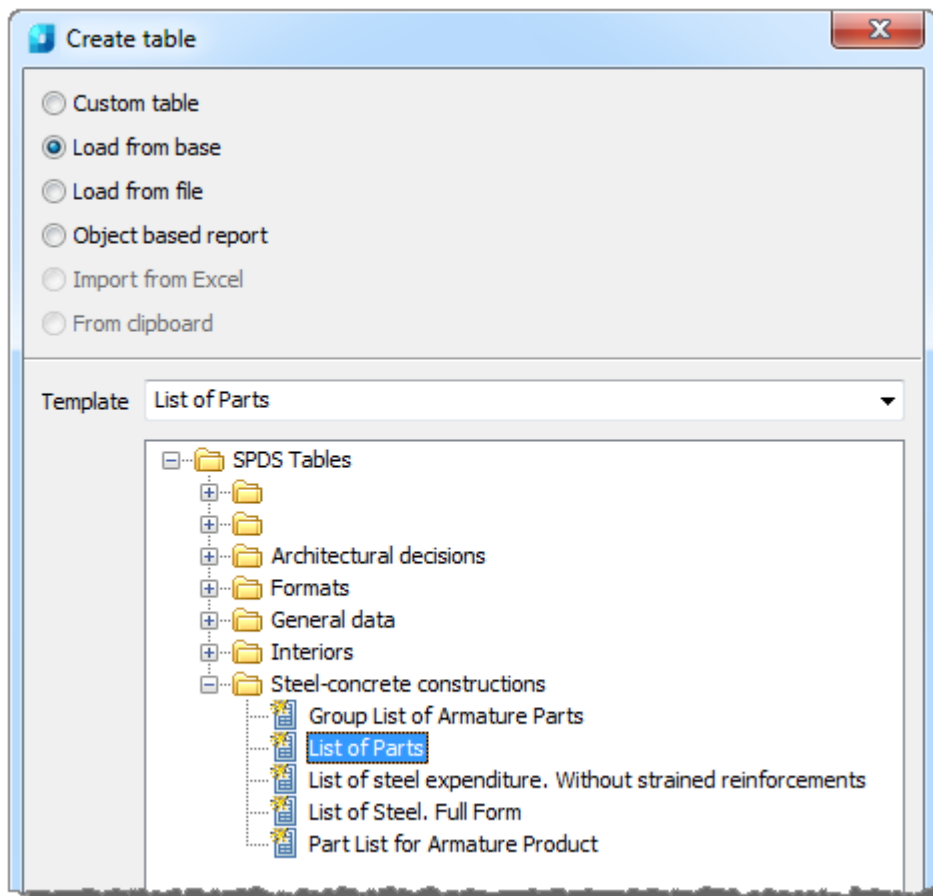

3. Choose the desired table type in the dialog box. All basic standard tables are present in the nanoCAD library.

**To insert a table from a file:**

1. Click the **Load from file** item.

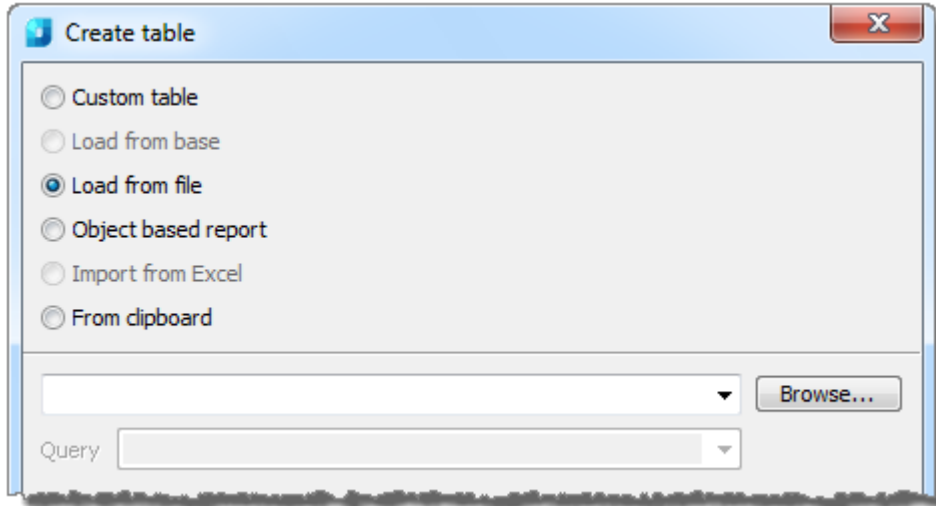

2. Click the **Browse** button and select the table file.

Supported formats:

- *tbl* - tables format;
- *dat* - data file or text file;
- *mdb* - Microsoft Access database;
- *xls* - Microsoft Office Excel table;
- *xlsx* - Microsoft Office Excel 2007 table;
- *csv* - table, cells are divided by commas;
- *txt* - standard text file;
- *xml* - XML document.

When loading the table from an *mdb* file, the list of base queries is displayed in the drop-down list:

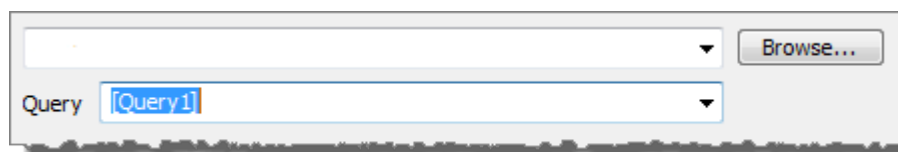

When loading the table from *xlsx* or *xls* files, it is necessary to select the list in the Excel document:

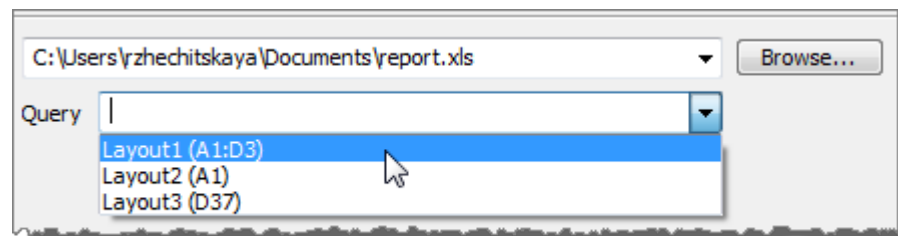

**IT IS IMPORTANT!** The list choice can be carried out after loading the table from a file.

**Accomplish this:**

1. In the **Source query** line, enter the required list from the document.

**NOTE:** In the table properties, the **Source file** line displays the path to the initial table file.

- Then in the **Table edit** dialog box click the **Update table from external source**  icon.

**NOTE!** To import tables from files, it is possible to drag a file from the browser to the **Table edit** dialog box.

When dragging a file from the browser into the table field, the imported table is added to the existing table.

When dragging a file from the browser into the dialog box field, the imported table replaces the existing table

**To generate an object base report:**

- Click the **Object based report** item.
- To choose the required objects, click the **Select** button:

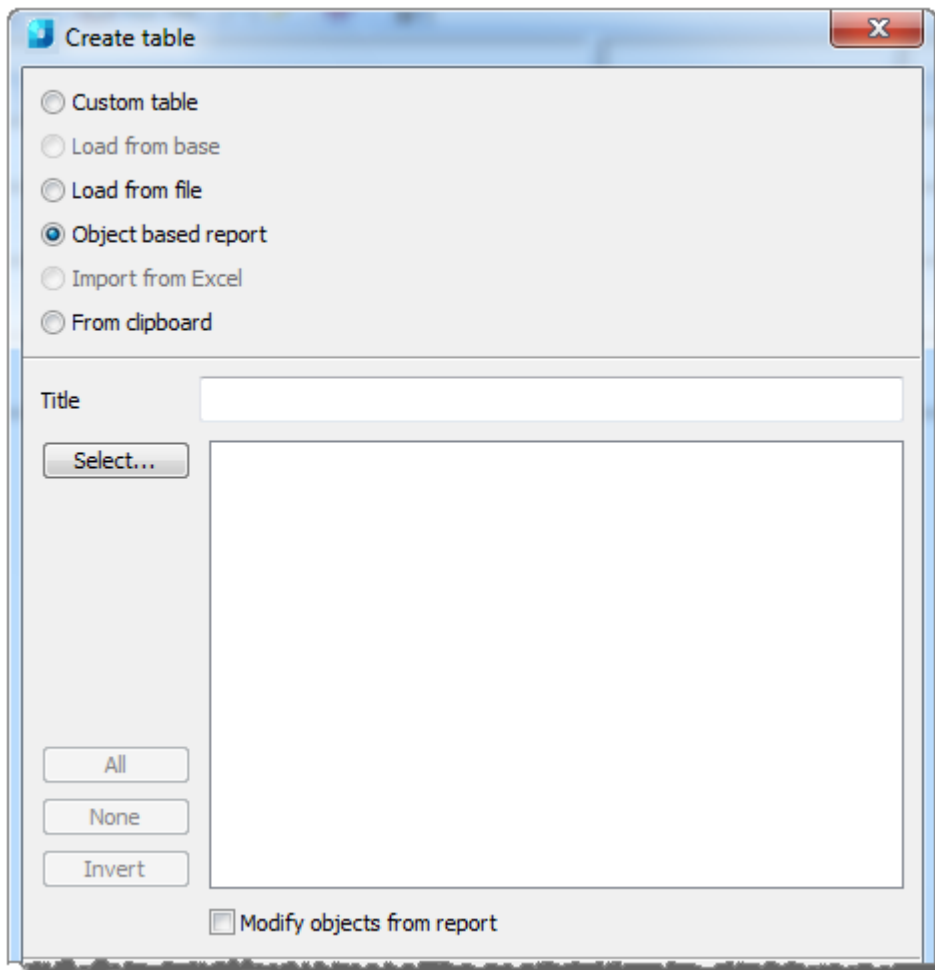

- Setting of search conditions is carried out in the **Quick Selection** dialog box:

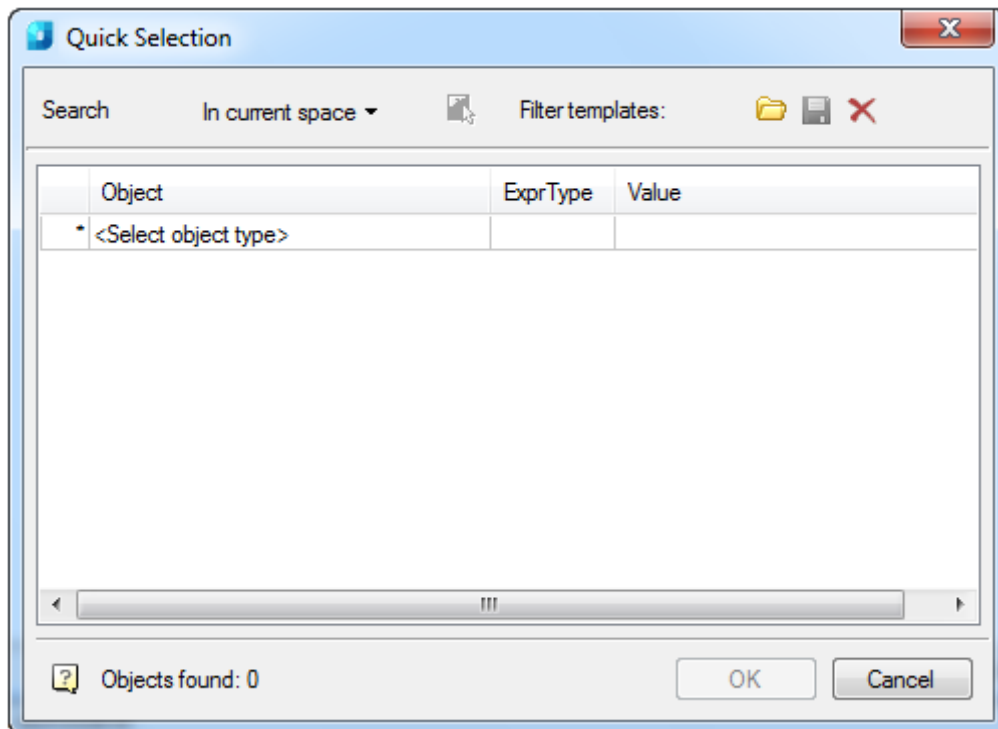

4. Which attributes of the chosen objects the report is based on are also set in this dialog box.

The attributes to be included in the report are switched by tags in the list or switches:

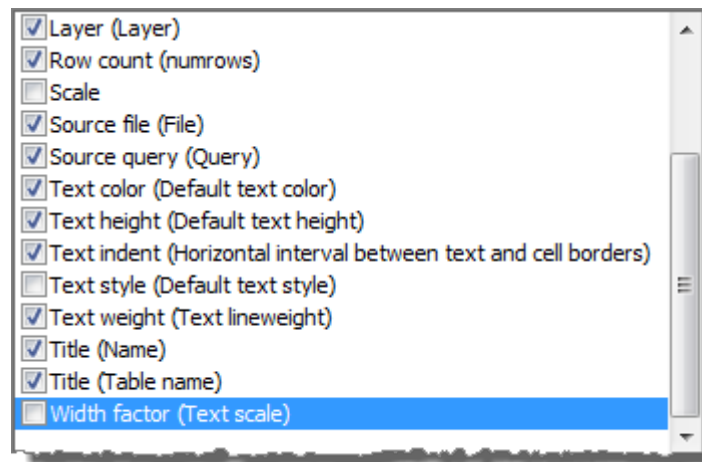

#### Buttons:

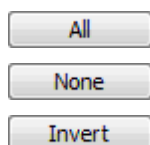

- All attributes are selected.
- The choice is removed from all attributes.
- Selection of attributes is inverted.

The report with a template of a view is created in the table:

```
=Iff(Exist(Object."AttributeName");Object."AttributeName";"")
```

This expression checks the existence of the given attribute line with the *AttributeName* name and uses its value in the cell. Otherwise, it leaves a cell empty:

	A	B	C	D	E
1	Report template				
	<a href="#">Section properties</a>				
1	= {Object.numcols; * otherwise	= {Object.«Decimal * otherwise	= {Object.Direction; * otherwise	= {Object.Name; if E * otherwise	= {Object.numrows; * otherwise
	Report				
2	7	..	true		45 C:\Dc

The number of columns in the table is defined by the number of chosen attributes.

**NOTE:** If the objects group was previously selected on the drawing and the **Tables**  command is activated, then you will be offered the option to create an object-based report.

### To import table from Excel:

1. Select the **Import from Excel** item.

**NOTE!** The document should be opened to make this item active.

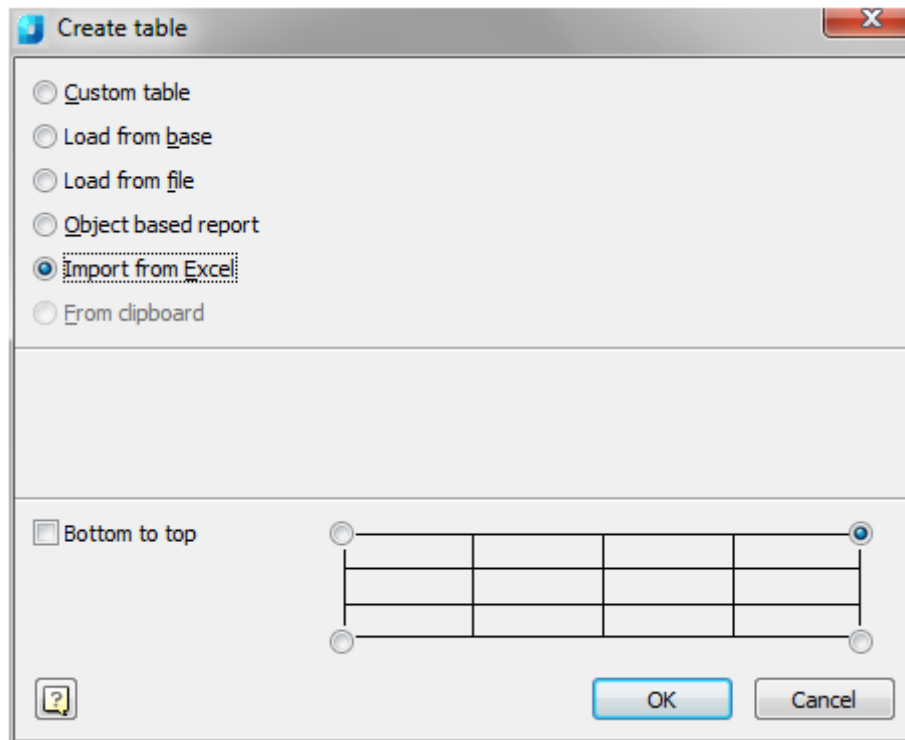

2. Choose the location of the base point:

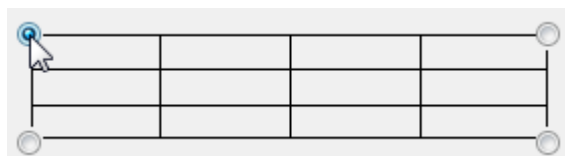

3. Choose the row numbering method:

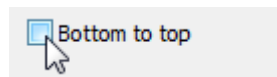

If the **Bottom to top** box is checked, the rows will be numbered in reverse order.

4. Click the **OK** button and pick the insertion point in the drawing.

## Editing Tables on the Drawing

The on-screen table editor is opened by starting the **In-place edit (ipedit)** command or left-clicking the table frame while holding down the **CTRL** key.

### To enter the content of a cell:

1. Place the cursor above the cell.
2. Left-click.

The active cell is then highlighted in green. The text entered in a cell is automatically condensed to fit the cell width.

The **Table Edit** toolbar is shown when a table is being edited on-screen.

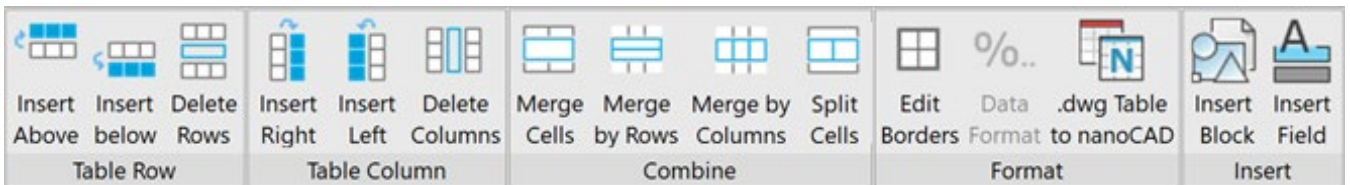

### Table Row Group

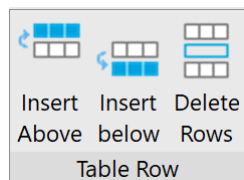

#### Insert above

Adds one line at the position where the selected cell is located.

#### Insert below

Adding one row at the bottom of the table.

#### Delete Rows

Deletes the row that contains the selected cell.

### Table Column Group

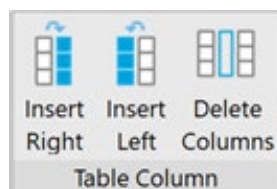

#### Insert Right

Adds one column to the table on the right.

#### Insert Left

Adds one column to the table on the left.

#### Delete Columns

Deletes the column that contains the selected cell.

### Combine Group

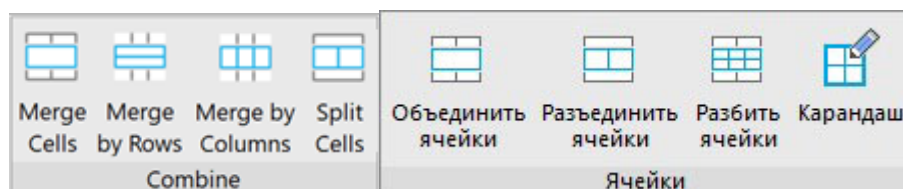

**Merge Cells**  
(Merge by Rows)  
(Merge by Columns)

Merges adjacent cells into one:

- Place the cursor over the cell that needs to be merged with other adjacent cells (the cell is highlighted in green).
- Confirm the cell selection by clicking the left mouse button.
- Move the cursor to the last cell to be merged (adjacent cells to be merged are also highlighted in green).
- Confirm the selection of the last cell by clicking the left mouse button.

**Split Cells**

Splits previously merged cells:

- Place the cursor on a cell that was previously combined from several cells (the cell is highlighted in green).
- Confirm the cell selection by clicking the left mouse button.
- Left-click again to split the cell into its initial cells.

*Format Group*

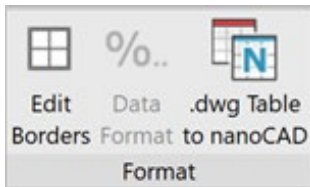

**Edit borders**

Modifies the properties of the table borders of one or more cells using the **Cell Border Properties** dialog box:

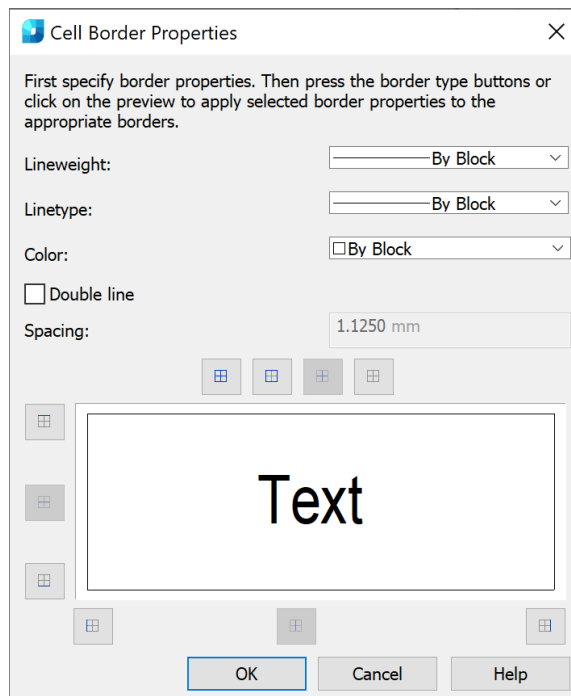

- First specify border properties.
- Then press the border type buttons or click on the preview to apply selected border properties to the appropriate borders.

**.dwg Table to nanoCAD**













Converts .dwg table to nanoCAD (**CONVERTTABLEA** command).



In the classic interface the **Edit .dwg Table** toolbar opens:



### Buttons:

 <b>Insert above</b>	Adds one line at the position where the selected cell is located.
 <b>Insert below</b>	Adds one row at the bottom of the table.
 <b>Delete Rows</b>	Deletes the row that contains the selected cell.
 <b>Insert Left</b>	Adds one column to the table on the left.
 <b>Insert Right</b>	Adds one column to the table on the right.
 <b>Delete Columns</b>	Deletes the column that contains the selected cell.
 <b>Merge Cells</b>	Merges adjacent cells into one.
 <b>(Merge by Rows)</b>	Merges two or more cells in a row.
 <b>(Merge by Columns)</b>	Merges two or more cells in a column.
 <b>Unmerge cells</b>	Splits previously merged cells.
 <b>Edit borders</b>	Modifies the properties of the table borders.
 <b>Insert Block</b>	Inserts a block.
 <b>Insert Field</b>	Inserts a field.

## Interface of the Table Editor Dialog

The full table editor (the **Table edit** dialog box) when the **Program objects** parameter is set to **Yes** in the **Edit – By double-click** section of the **Main options** tab of the **nanoCAD Design Settings (PARAMS)** dialog box, can be opened:

- by double-clicking on the frame inserted into the drawing table,
- by right button clicking on the table frame (the full table editor will be opened if you press **CTRL**).

The **edit** and **fedit** commands allow you to open the **Table edit** dialog box, it does not matter what value is chosen for the **Program objects** option.

You can also open the **Table edit** dialog by selecting the table, clicking the right button and selecting the **Edit** command in the context menu.

The **Table edit** dialog box:

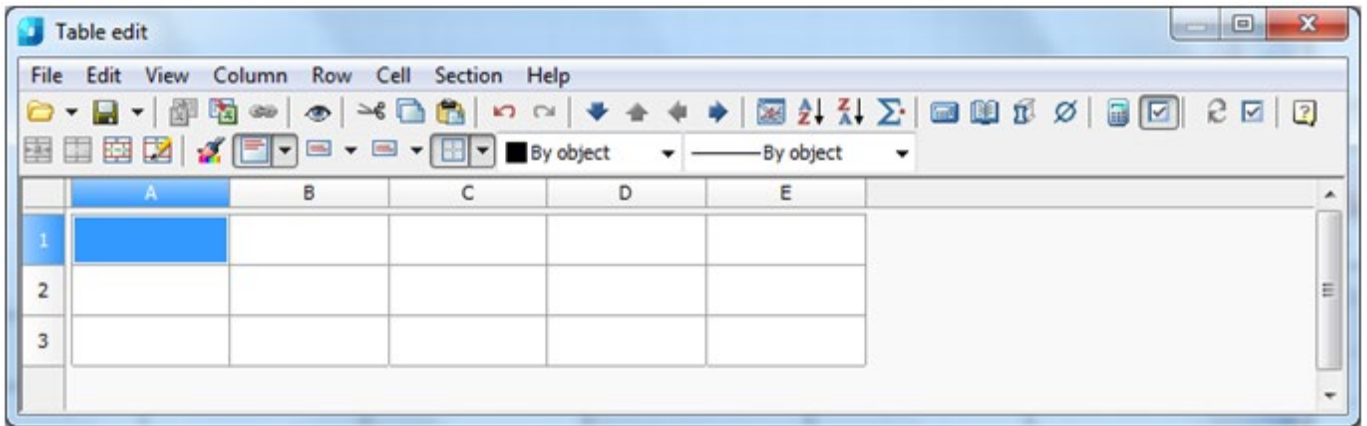

The dialog box contains:

- standard pull-down menus

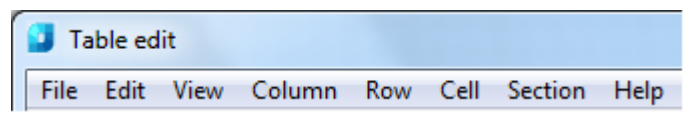

- tool palette buttons



- rulers with sliders allowing column width or row height to be quickly adjusted
- the cell grid with name headers

	A	B	C	D	E
1					
2					
3					

- status bar with transparency and scale sliders.

Each table section has a header:

- First page header
- Header
- Last page header
- Report header
- Report template
- Report
- Report sum
- First page footer
- Footer
- Last page footer

Click the left mouse button on a row or column name to select it.

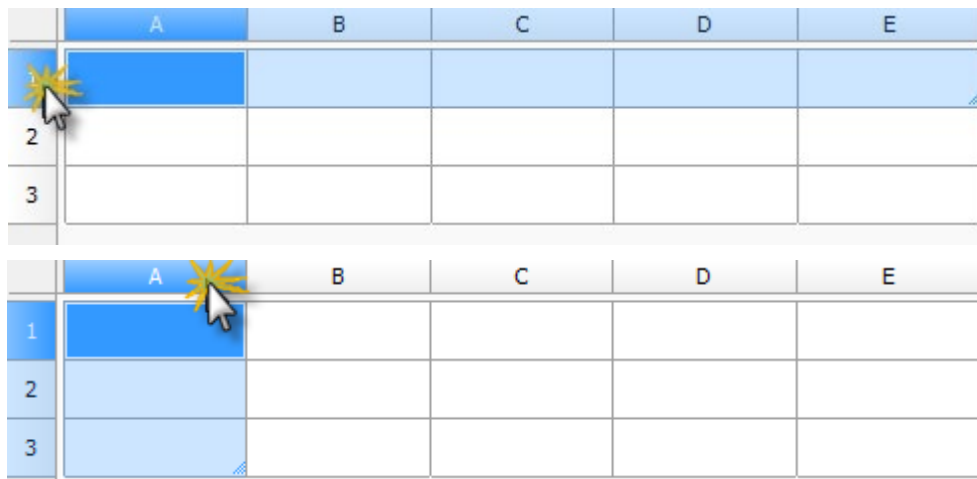

	A	B	C	D	E
1					
2					
3					

To select the table, click the rectangle at the intersection of the lines and columns names:

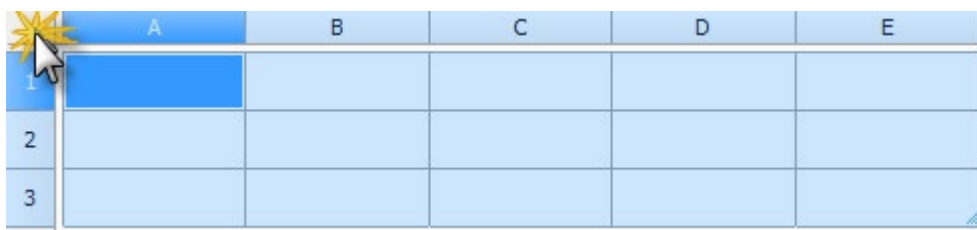

	A	B	C	D	E
1					
2					
3					

Names (addresses) of table cells are fully equivalent to those used in MS Excel: columns are marked alphabetically (A, B, C, D, ... , Z; AA, BB etc.) while rows are marked with ordinal numbers.

### ***Filling of adjacent cells with data***

To accelerate the data input in the table, it is possible to use the function of automatic data filling. The table editor can automatically continue a line of numbers, number combinations and text with a set pattern. By selecting several cells and dragging the filling marker, it is possible to quickly fill in the data lines with the different types.



### ***Filling cells with sequences of numbers or combinations of numbers and text with a set pattern:***

***For example: Filling cells with sequences of 1, 2, 3, 4, 5 numbers.***

1. Select the first of the filled cells:

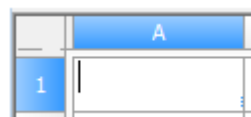

	A
1	

2. Enter the initial value for the values line:

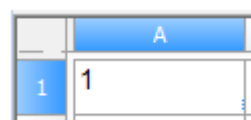

	A
1	1

3. Enter a value in the following cell to set the filling pattern:

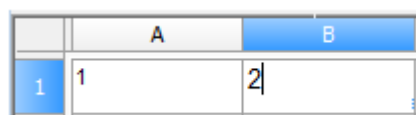

	A	B
1	1	2

4. Select the cell or cells containing the initial values:

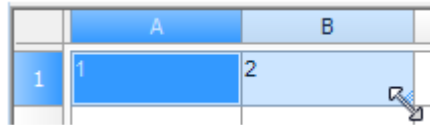

5. Drag the filling marker over the range with which it is necessary to fill:

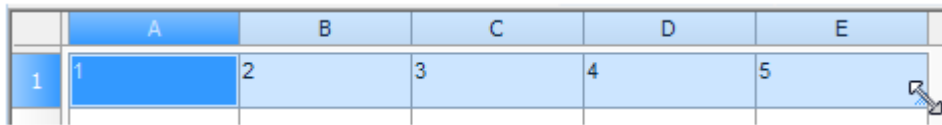

6. The cells will be filled with the set sequence of numbers:

	A	B	C	D	E
1	1	2	3	4	5

### Examples:

1. If the sequence 2, 4, 6, 8... is required, enter 2 and 4.
2. If the sequence 2, 2, 2, 2... is required, the second cell can be left empty.
3. The sequence filling proceeds as shown in the table below:

Initial value	Line extension
1, 2, 3, ...	4, 5, 6, ...
First period, Second period, ...	Third period...
Article 1, Article 2, ...	Article 3...

**NOTE!** To fill in an increasing order, drag the marker down or to the right. To fill in a decreasing order, drag the marker up or to the left.

Use the autofilling to continue lists containing the values from collections (main menu/rows/user sorting).

### Cell colors

=Object.Name

Cell containing an expression.

CSN M 12x120#

Not edited cell, for example, in report.

#ERR

Cell with a mistake in expression.

60

Cell containing data of report section.

## Basic Tools

### The files tools:



#### Open table:

Allows a data set from a previously created \*.dat file to be imported, or a standard table template from the nanoCAD library to be imported.

Clicking the black triangle shows additional buttons which are used to select the data source:



- Insert a table from the library.



- Insert a table from an external file \*.tbl, \*.dat, \*.mdb, \*.txt, \*.csv, \*.xml, \*.xls, \*.xlsx.

If the Excel file is chosen, only the first list will be inserted.



#### Save to file:

Exports the cell data to a special \*.dat file format, or saves it in the nanoCAD library.

Clicking the black triangle shows additional buttons used to select the desired destination:



- Save table in nanoCAD library.



- Export table to an external file \*.dat, \*.txt, \*.csv, \*.xml, \*.xls.



#### Export to Excel:

Exports the table data to MS Excel. Clicking this button creates a new Excel worksheet containing all the table data with identical formatting.



#### Import from Excel:

Imports calculated data from an open MS Excel worksheet.

### The standard windows clipboard tools:



#### Cut:

Copy the selected data into the clipboard and delete from the table.



#### Copy:

Copy the selected data into the clipboard.



#### Paste:

Paste data from the clipboard.

### Undo and redo last change tools:



#### Undo last change:

Undo last change.



#### Redo last change:

Redo last change.

### Formatted cell navigation tools:



#### Move row down:

Moves the selected row one position down.



#### Move row up:

Moves the selected row one position up.



**Move column left:**

Moves the selected column one position left.



**Move column right:**

Moves the selected column one position right.



**Page division:**

This tool is intended for dividing a table into multiple fragments without losing its integrity.

Use this function to split a large table in order to place it on a smaller sheet of paper, while still being able to edit it as a whole.

**Tools used for sorting cells by contents:**



**Sort ascend:**

Sorts rows in ascending order of cell values in the current column (column of the selected cell).



**Sort descend:**

Sorts rows in descending order of cell values in the current column (column of the selected cell).

**Other tools:**



**Create summary function:**

Summarises the contents of the chosen cells:

- Select the cell in which it is required to calculate the sum.
- Click the button .

	A	B	C	D
1	=summ()			
2		3		2
3				

- Select the cells which are to be summarised:

	A	B	C	D
1	=summ(B2:D2)			
2		3		2
3				

- Press **ENTER**:

	A	B	C	D
1	5			
2		3		2
3				



**Open calculator:**

Opens the **Calculator** window.



**Open Notepad:**

Opens the **Notepad** window.



**Insert material:**

Use this tool to insert formatted rows of material into the table. Click the icon to open the **Material** dialog box:

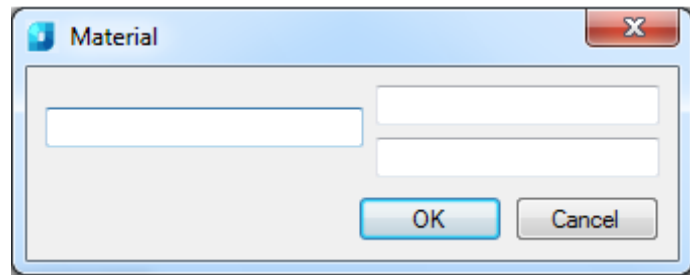

**Special Symbols:**

Allows a special symbol to be inserted from the menu.



**Recalculate Table:**

This button is used to manually update the calculated cell data after editing reference cell values or altering expressions.



**Automatic calculation:**

Operates a mode of automatic recalculation of the values of the table cells.

By default, the automatic calculation mode is included.



**Update reports:**

Click this button to update the report.



**Automatic report update:**

Operates a mode of automatic recalculation of the report. By default, the automatic report update mode is included.

*Tools to work with the cells:*



**Group selection:**

Merges multiple cells into a single cell.



**Ungroup selected cells:**

Restores the original cells from merged cells.



**Change count of rows and columns:**

Use to change the count of rows and (or) columns in the chosen cells range:

- Select one or several cells.
- Click the Change count of rows and columns button.
- In the **Regroup** dialog box that appears, enter the required values for breakdown

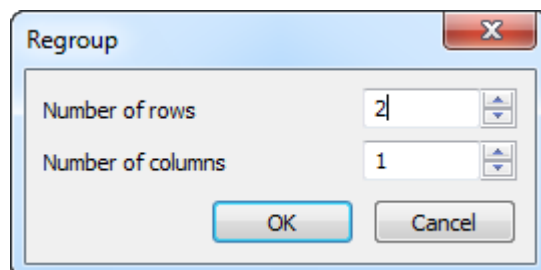



### Split table cells with pencil tool

Use to insert new cells by manually drawing new grid lines:

- Specify the start and end point of a line which will divide each cell that is crossed by it into two:

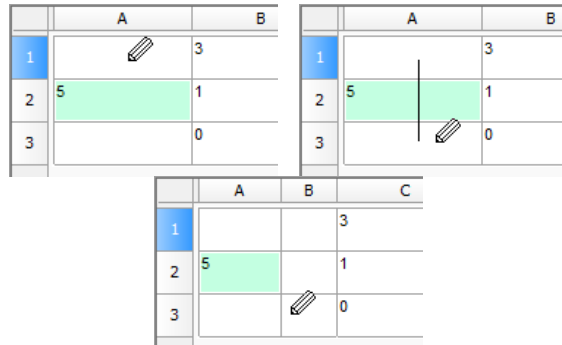

- Right-click on a cell border to delete this border:

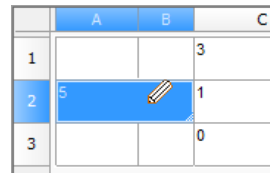

- Click Split table cells with pencil tool button to finish.

### Text alignment tools



#### Text alignment

Use to control the text alignment in the selected cells. Clicking the black triangle brings up additional buttons:



The remaining tool icons are self-explanatory.



### Management tools of cell borders display

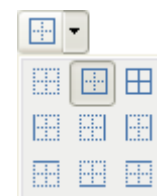

#### Borders:

Use to display or hide the borders of the selected cells. Clicking the black triangle brings up additional buttons used to toggle border visibility:



-  - No border lines.
-  - Display all lines around the selected cells.
-  - Display all borders - inner and outer.

The remaining tool icons are self-explanatory.

To set the border parameters:

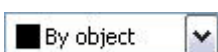

#### Border



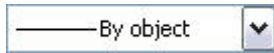

**Color:**  
**Border**  
**Lineweight:**

- It is necessary to select again the color or lineweight.
- Choose the border (use the **Borders**  command) to which it is necessary to apply the set parameters.

## Cell Properties

The parameters of table cells are set in the **Cell properties** dialog box:

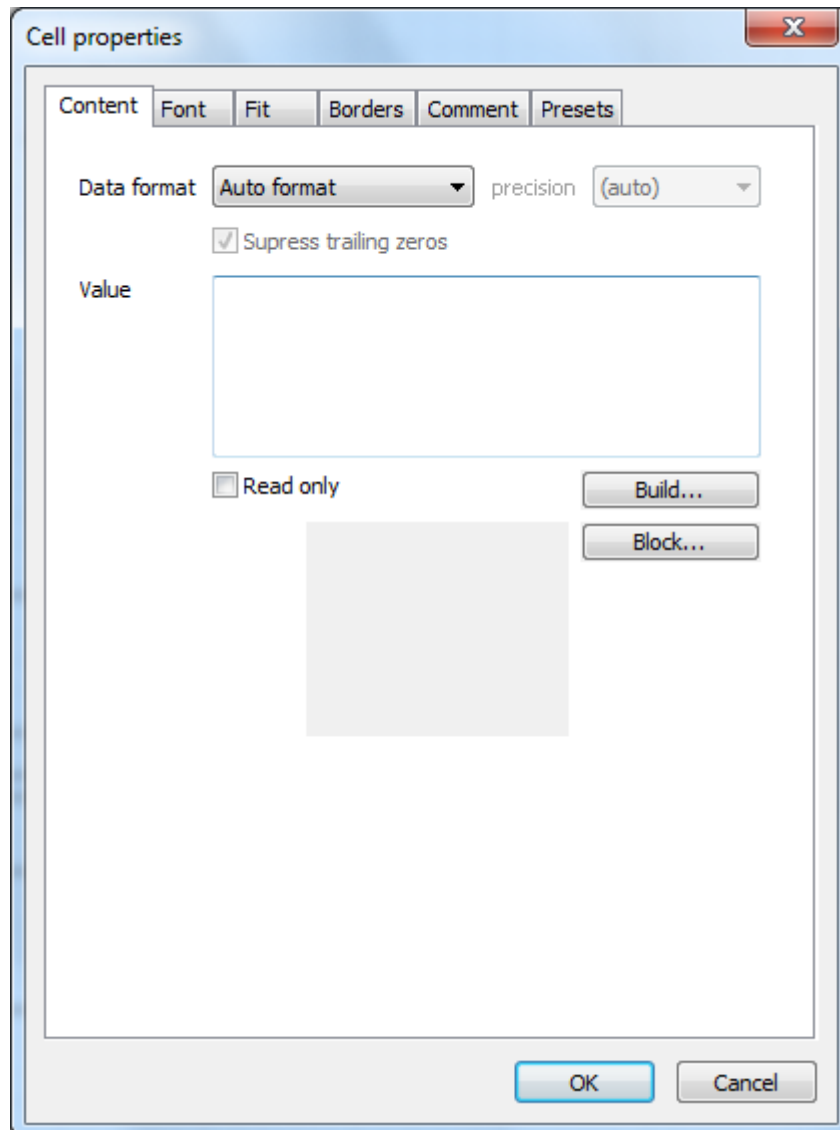

### To edit the properties of a cell:

1. Select the required cell in the **Table edit** dialog box.
2. Select the **Properties** command from the right-button menu or use the **CTRL** + **ENTER** key combination or double click on the cell.
3. Set necessary properties in the **Cell Properties** dialog box.

**NOTE:** The action of this command is similar to **Cell Properties** on the **Table edit** toolbar.

### To edit several table cells:

1. Select the required cells.

2. Select the **Properties** command from the right-button menu or use the **CTRL** + **ENTER** key combination or double click on the cell.
3. Set necessary properties in the **Cell Properties** dialog box.

**NOTE:** The effect of this command is similar to **Cells Properties** on the **Table edit** toolbar.

## Editing the Size of Rows and Columns

To adjust the height of a row or the width of a column, use the sliders located on the rulers (horizontal and vertical). Move the slider by clicking it and holding down the left mouse button whilst dragging it. While adjusting the height or width, their values are highlighted in color for easy monitoring.

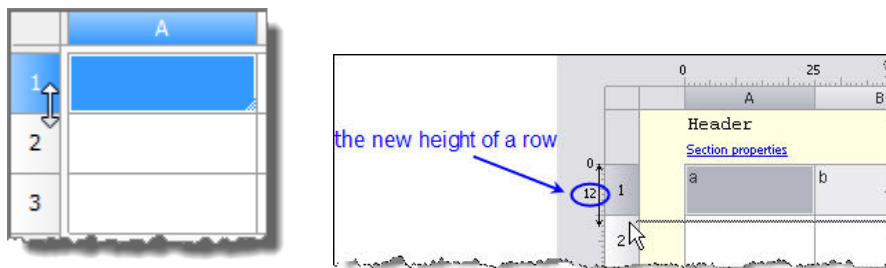

Row height and column width may also be set in the property dialog box that can be opened by right-clicking the header of a row or column.

1. In this dialog box, enter the desired width/height in millimetres.

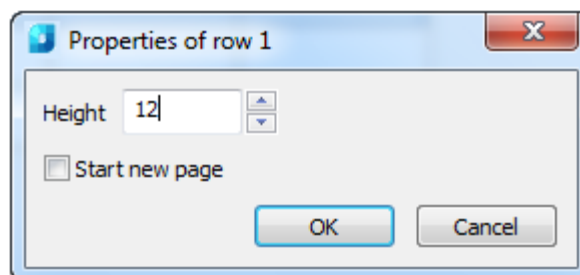

2. In the **Properties of column** dialog box, the **Hidden** checkbox is available. Using it, you can hide the display of the selected column on the drawing. It can be displayed in the editor mode.

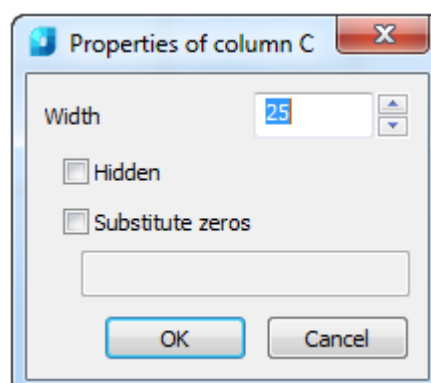

It is also possible to hide a column using the column context menu.

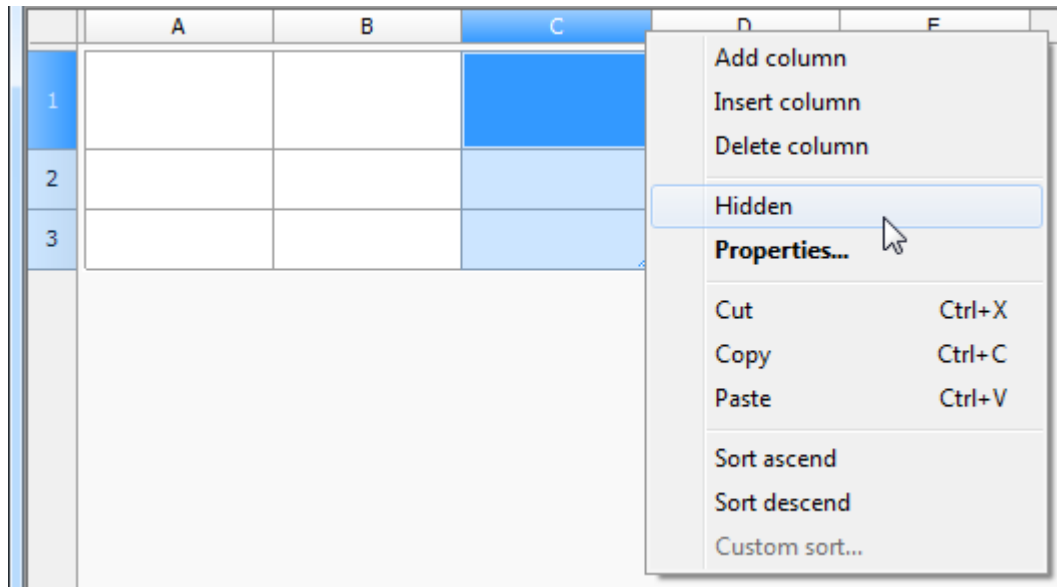

The **Substitute zeros** command (in numerical cells with a zero value, the cells should have a numerical format) replaces the cells contents with the set text.

**NOTE!** The format of the cell text value is established in the cell properties on the **Content** tab.

Close the dialog box by clicking **OK**.

## Work with MS Excel

### Importing a Table from Excel



Ribbon: **Annotation – Tables** –  **Import table from Excel**



Menu: **Draw – Table** >  **Import Table**



Toolbars: **Tables, Utilities** – 



Command line: **TABLEEXCELIMPORT**

The command transfers data from an *open worksheet* in MS Excel:

1. In the open Excel list, select the cell data from which it is required to import to the nanoCAD table.
2. Click the **Import table from Excel** button in the **Table Edit** dialog box.
3. The data will be transferred into the table.

### Exporting a table to Excel



Ribbon: **Annotation – Tables** –  **Export table to Excel**



Menu: **Draw – Table** >  **Export Table**



Toolbars: **Tables, Utilities** – 



Command line: **TABLEEXCELEXPOR**

The command is intended for transferring tabular data to MS Excel. After running the command, a new Excel workbook opens and all table data is transferred to it, preserving the cell formatting set in the table.

**NOTE!** The following data are not exported to Excel from the nanoCAD tables:

- nanoCAD blocks;
- Formatted text;
- Expression mismatched Excel format.

## Page Division



**Page division** divides a table into multiple fragments without losing its integrity. Use this function to split a large table in order to place it on a smaller sheet of paper, while still being able to edit it as a whole.

- Using this command brings up the **Page division** dialog box.

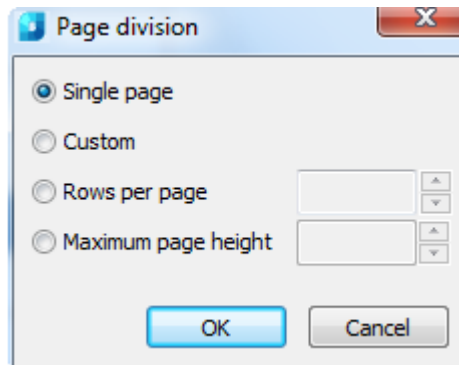

- Check the **Single page** box to disable page division.

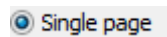

- Choose the division method:

- Custom.** The table can be divided into any parts.

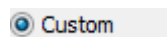

The page break before a row is set by the **Start new page** command from the context menu.

	A	B	C	D
	Header			
1	Header			
	Data			
3	a	g	n	
4	b	h	o	
5	c	j	p	
6	d	k	q	
7	e	l	r	
8	f	m	s	
	Footer			
10	Footer			

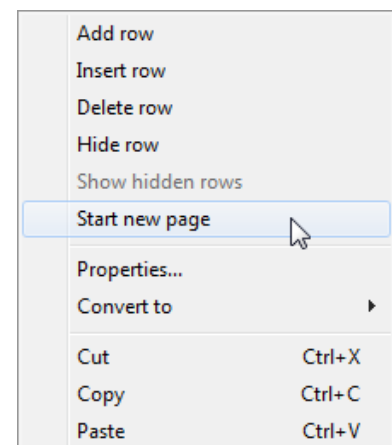

Close the dialog box. In the table edit window the break will be marked by a border, this makes it possible to change a row height.

	A	B	C	D
	Header			
1	Header			
	Data			
3	a	g	n	
4	b	h	o	
5	c	j	p	
6	d	k	q	
7	e	l	r	
8	f	m	s	
	Footer			
10	Footer			

On the drawing, the table with the break will look as follows:

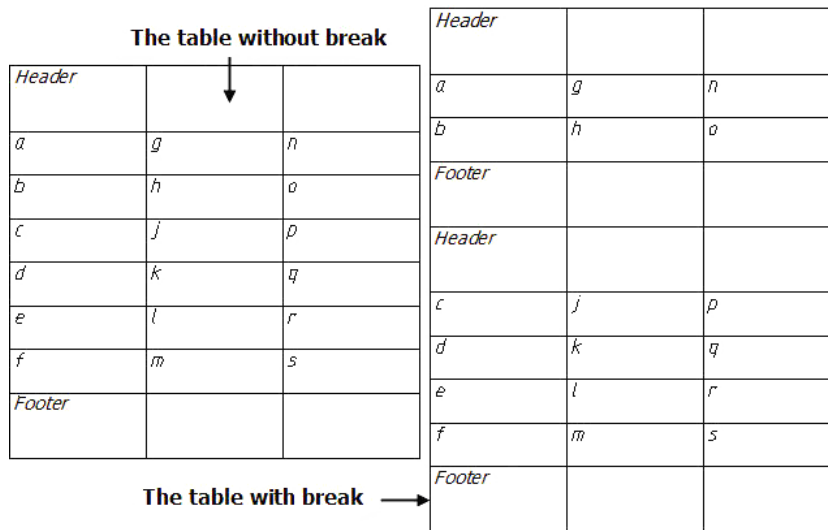

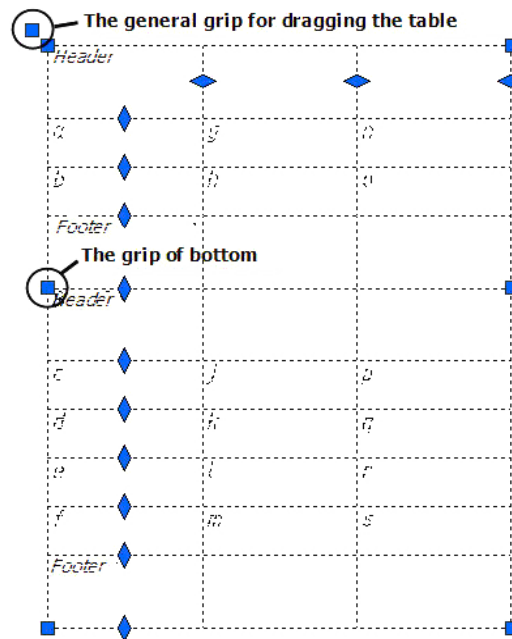

The parts of the divided table can be moved independently of each other within the drawing. Double click on any part to open the table editor.

- *By row count* enter the desired number of rows in the fragment. Headers do not count.

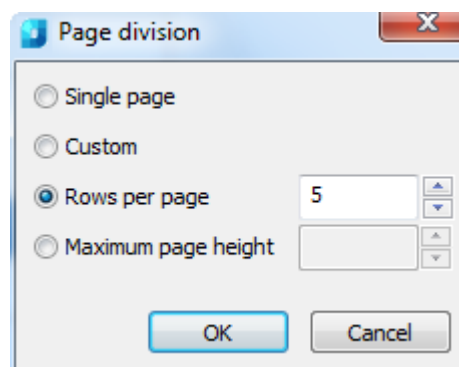

In the example, the table will be divided into separable parts, each of them will consist from 5 filled rows:

<b>KEY : EXTERNAL CLADDING</b>	
<b>CS</b>	COLORSTEEL, CORRUGATE
<b>TF</b>	9mm TITAN FACADE PANELING
<b>ST</b>	SELECTED STONE CLADDING
<b>BL</b>	200mm BLOCK MASONRY

<b>KEY : INTERNAL LINING</b>	
<b>TV</b>	SELECTED TILES ON 9mm VILLABOARD
<b>LP</b>	12mm MDF LAMINATE PANELLING
<b>GB</b>	13mm GIB BOARD
<b>VP</b>	9mm VILLA BOARD

- *By maximum page height* enter the total height of the fragment, in millimetres, using the current scale.

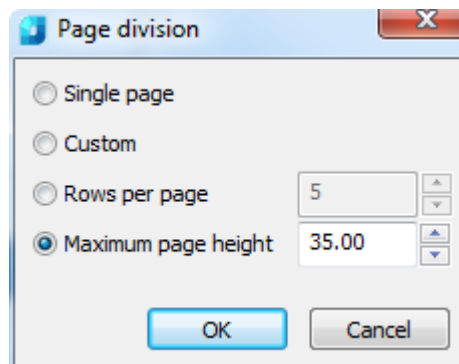

In the example, the table will be divided into separable parts in such way that the total height of the filled rows of each parts should be less than 35mm:

KEY : EXTERNAL CLADDING	
<b>CS</b>	COLORSTEEL, CORRUGATE
<b>TF</b>	9mm TITAN FACADE PANELING
<b>ST</b>	SELECTED STONE CLADDING

<b>BL</b>	200mm BLOCK MASONRY
KEY : INTERNAL LINING	
<b>TV</b>	SELECTED TILES ON 9mm VILLABOARD
<b>LP</b>	12mm MDF LAMINATE PANELLING

<b>GB</b>	13mm GIB BOARD
<b>VP</b>	9mm VILLA BOARD

The parts of the divided table can be moved independently of each other within the drawing.

## Convert Tables

### Converting .dwg tables to nanoCAD tables



Ribbon: **Annotate – Tables** >  **Convert .dwg Tables to nanoCAD**



Menu: **Draw – Tables** >  **Convert table AutoCAD to nanoCAD**



Toolbar: **Utilities** – 



Command line: **CONVERTTABLEA**

The command is intended to convert *.dwg* tables to *nanoCAD* tables with the possibility of further editing using nanoCAD.

To convert a table, just call the command and select the table.

The actual dimensions of the original graphics are multiplied by the scale of characters, therefore if you get a table with zero row height, you should change the scale of characters in accordance with dimensions of the original graphics.

### Converting nanoCAD tables to .dwg tables



Ribbon: **Annotate – Tables** >  **Convert nanoCAD tables to .dwg**



Menu: **Draw – Tables** >  **Convert table nanoCAD to AutoCAD**



Toolbar: **Utilities** – 



Command line: **CONVERTTABLEN**

The command is intended to convert *nanoCAD* tables to *.dwg* tables.

## Cell Properties

The parameters of table cells are set in the **Cell properties** dialog box.



**To edit the properties of a single cell:**

1. Select the required cell in the **Table edit** dialog box.
2. Select the **Properties** command from the right-button menu or use the **CTRL** + **ENTER** key combination or double click on the cell.

**NOTE:** The action of this command is similar to **Cell Properties** on the **Table edit** toolbar.

**To edit several table cells:**

1. Select the required cells.
2. Select the **Properties** command from the right-button menu or use the **CTRL** + **ENTER** key combination or double click on the cell.

**NOTE:** The effect of this command is similar to **Cells Properties** on the **Table edit** toolbar.

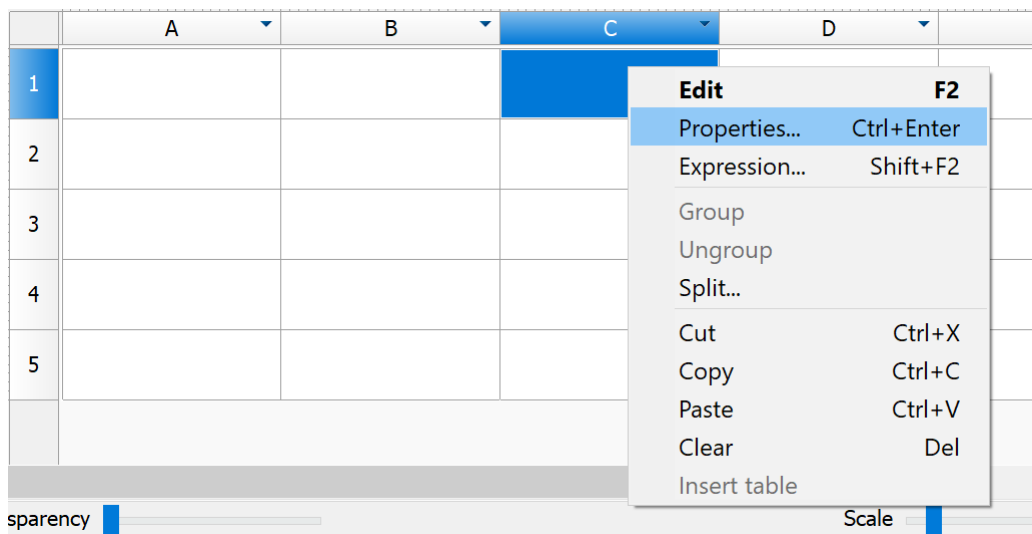

There are six tabs:

- In the **Content** tab you can specify the data format and formula to calculate a value:

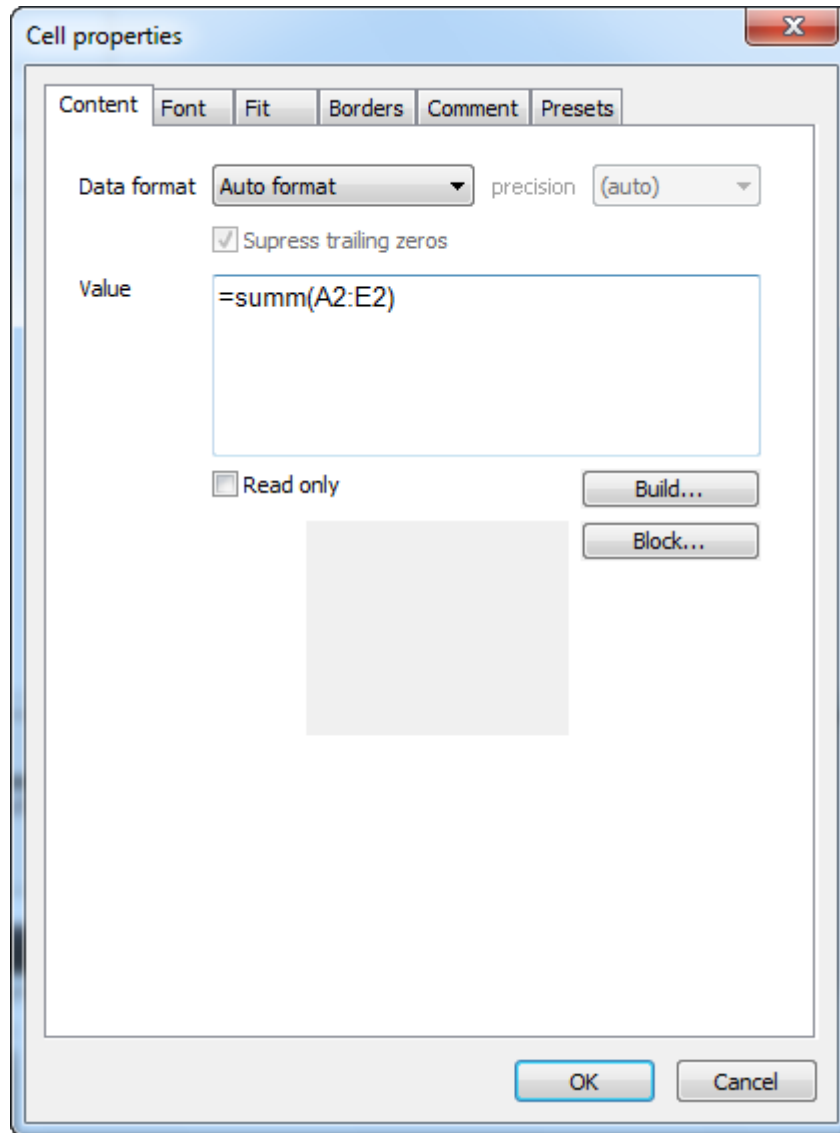

You can specify the data format and enter the value for the cell. Select the **Read only** checkbox to prevent cell editing. Such cells are highlighted.

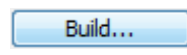
 - Opens the **Expression builder**.

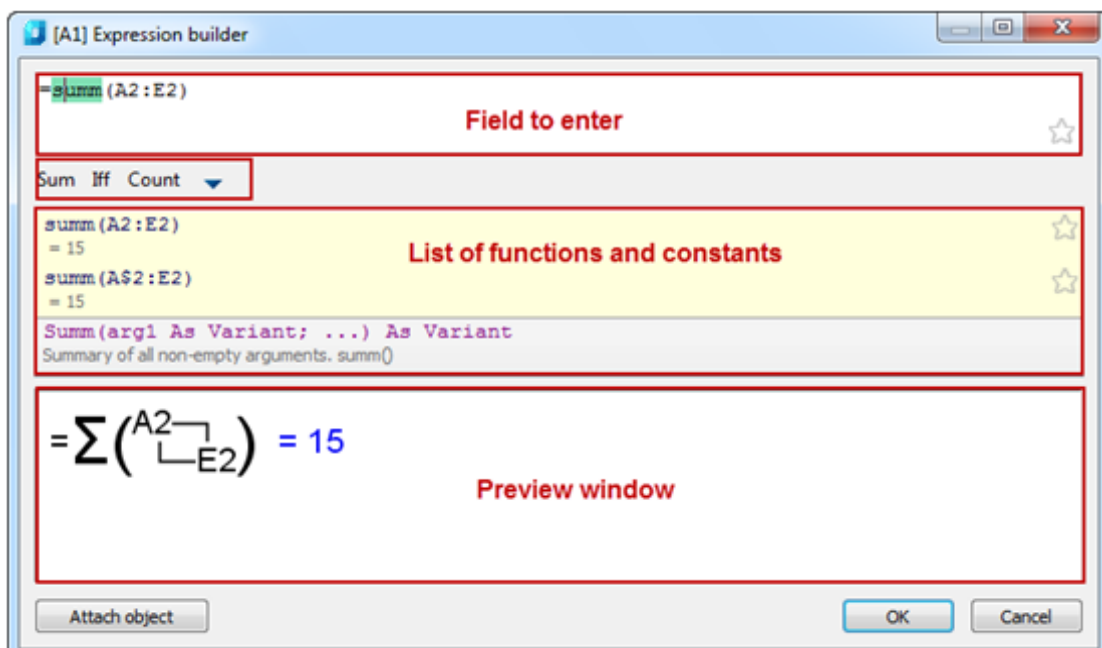

**Block...** - Insert block into the cell.

Select a block in the current drawing. You can select another file using **Open** menu

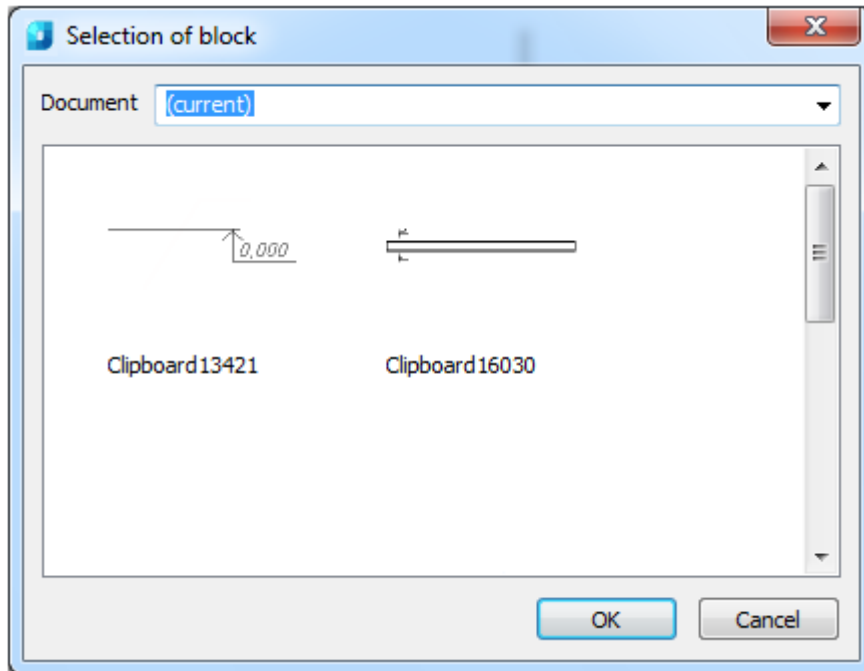

After block selection, it is displayed in the cell properties dialog box and in the table cell.

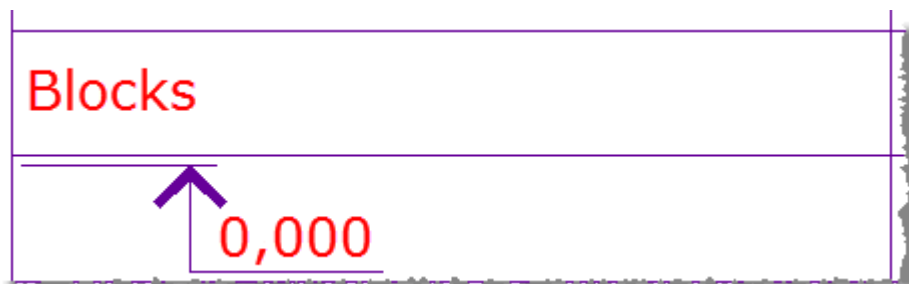
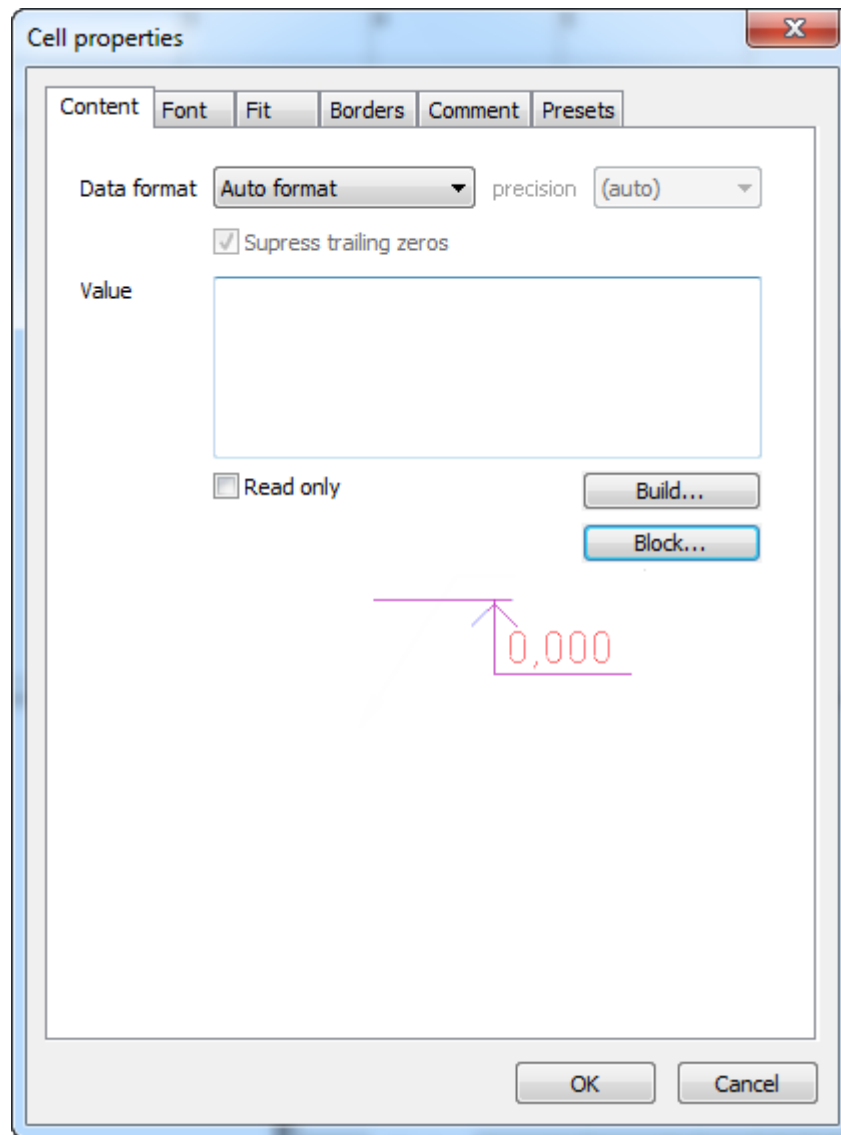

To detach a block, select **Remove block** in the **Selection of block** dialog box.

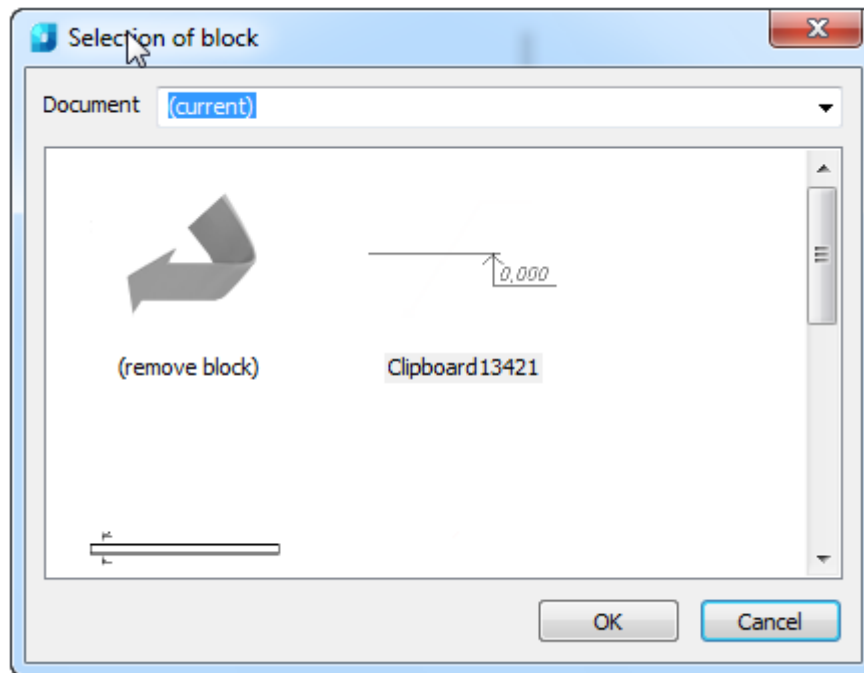

- In the **Font** tab you can specify text font, symbol color, line weight, indent, text angle and text scaling.

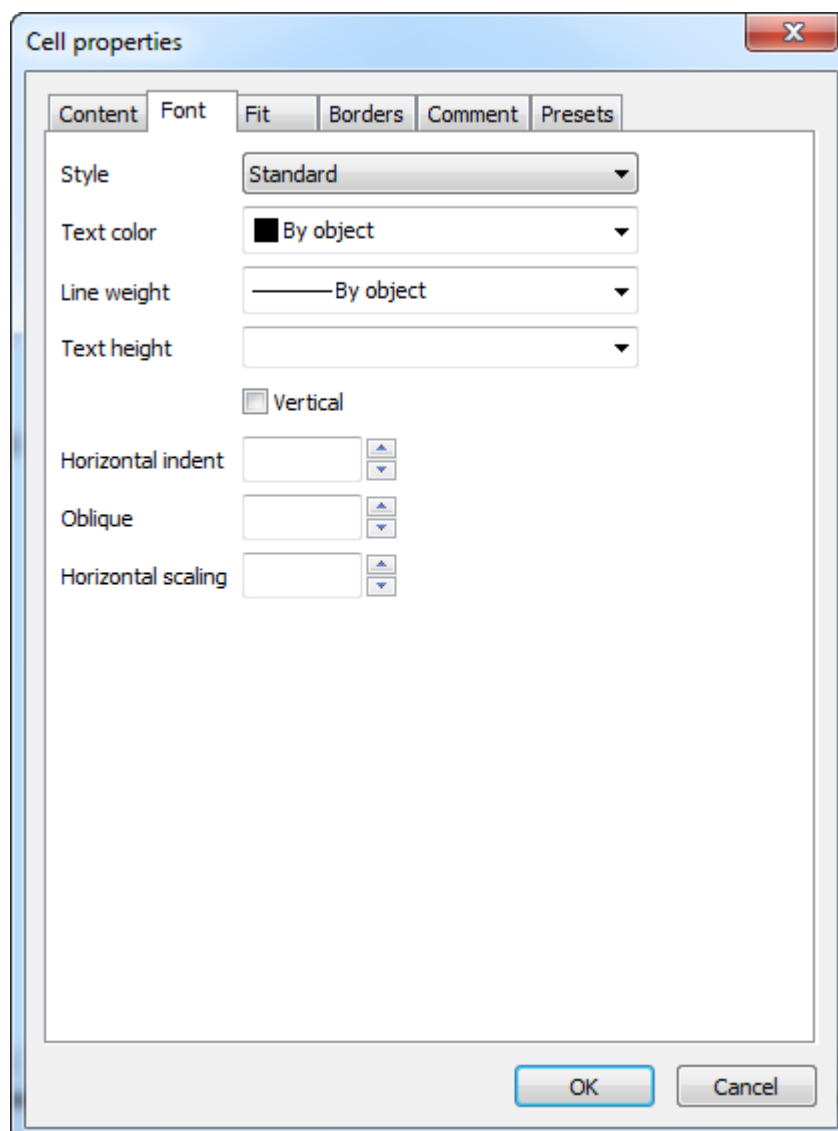

The **Vertical** checkbox changes the text direction to vertical.

If the **Oblique** and **Horizontal scaling** fields are empty, their values are taken from the text style. If the **Horizontal indent** field is empty, its value is taken from the table settings.

- In the **Fit** tab you can specify **cell width** and **height** and fitting parameters.

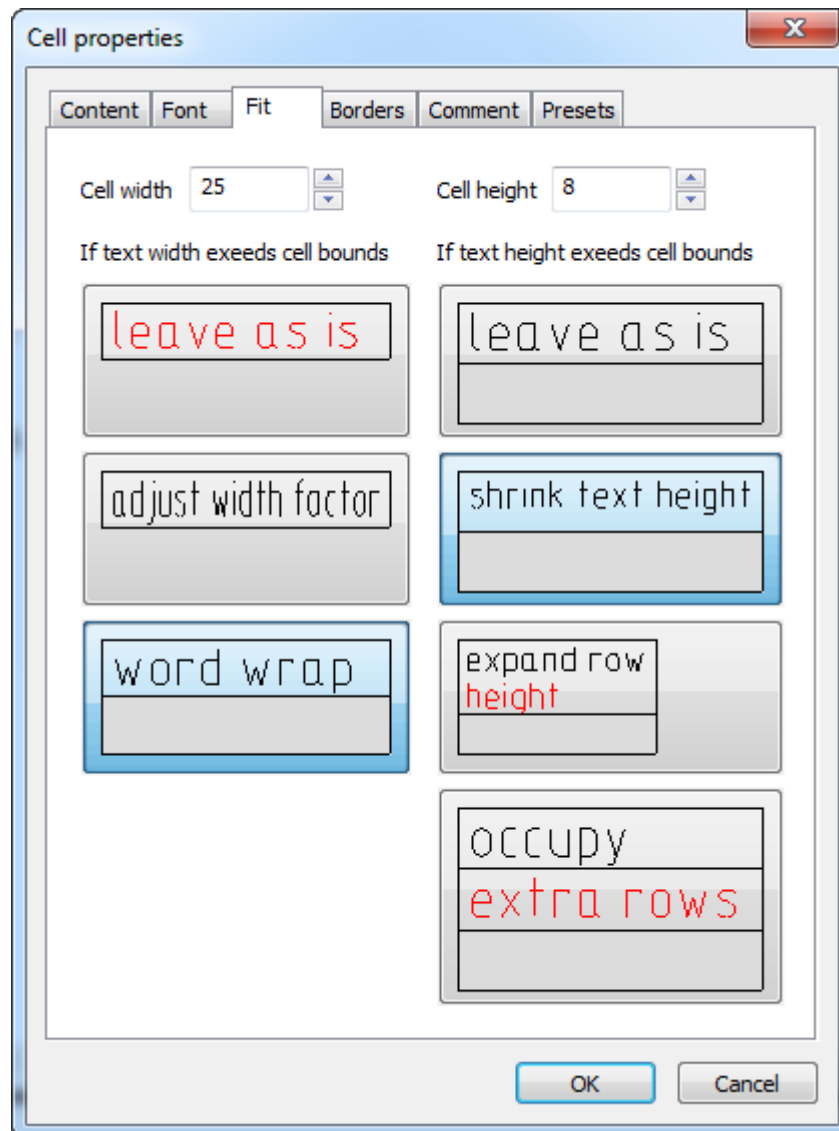

If text width is more than cell width:

leave as is	is
adjust with factor	
word wrap	

If text height is more than cell height:

leave as is		
shrink text height		
expand row height		
occupy extra rows		

**Occupy extra rows** does not change the row's number in the table, the required row is made higher by the required number of times and lined.

- In the **Borders** tab you can specify the type, weight and color of the lines of the selected cell. You can control the display of cell borders. To switch border display on/off, select one of the buttons:

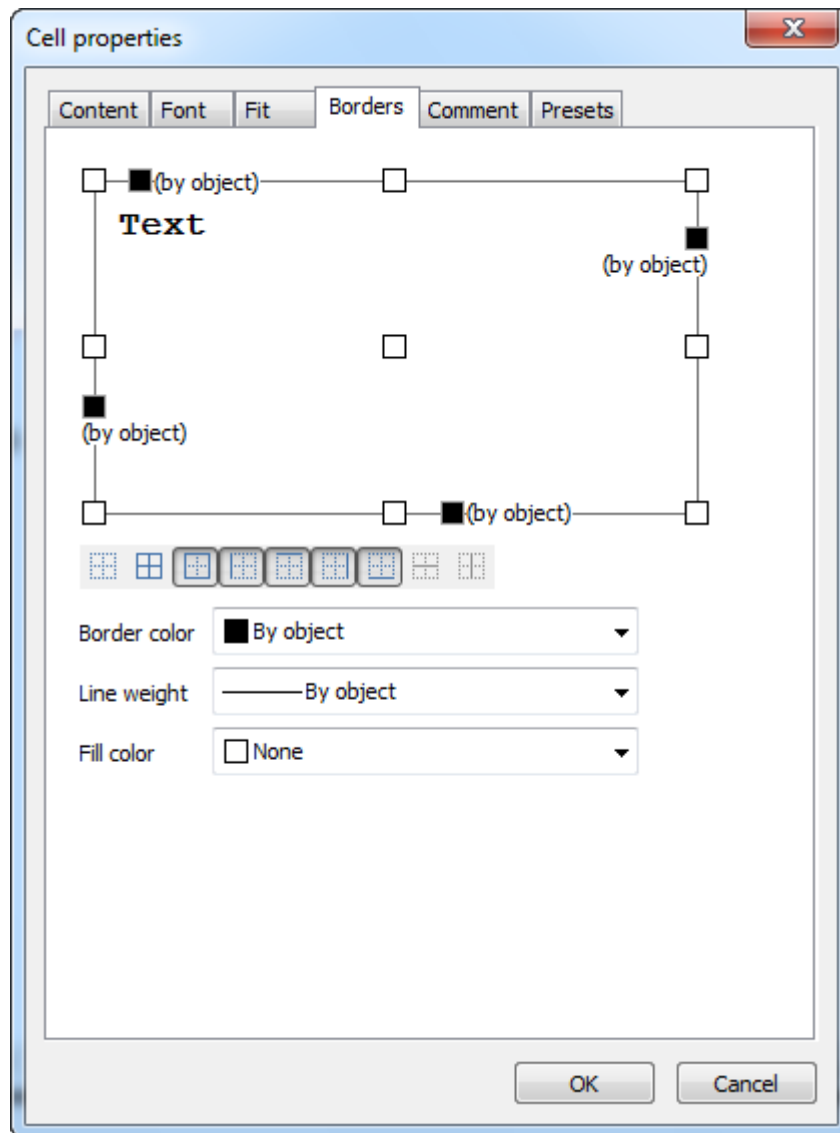

Or click near the cell border in the preview area. To align text in the cell, click the symbol  in the cell.

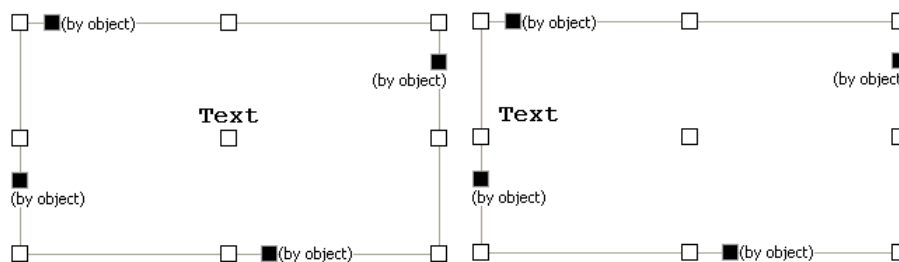

To specify the color of the border, click the symbol  and select a color from the list.

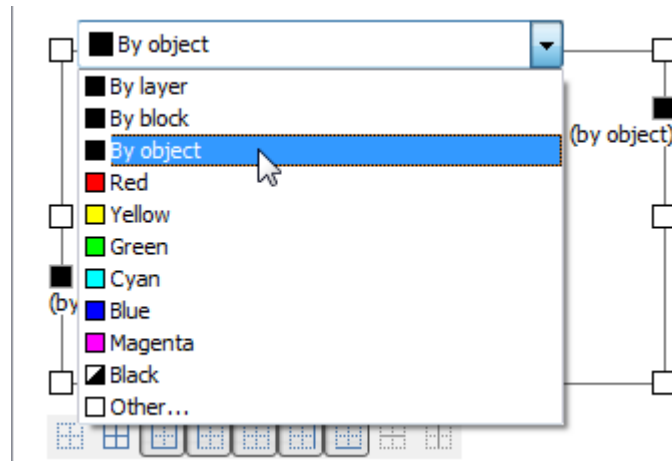

To specify the line weight of the border, select the *Line weight* field and select the weight from the list.

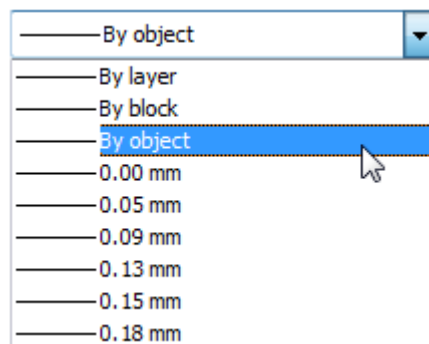

The color and weight of cells and their fill color can be specified in the tab.

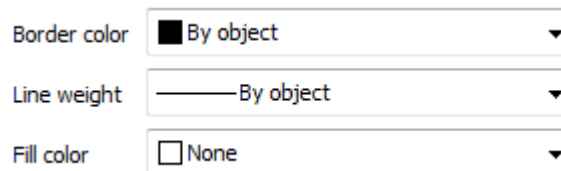

To apply a new color and weight, click the border or use the buttons.



- *Comment* tab. Field to enter a comment.



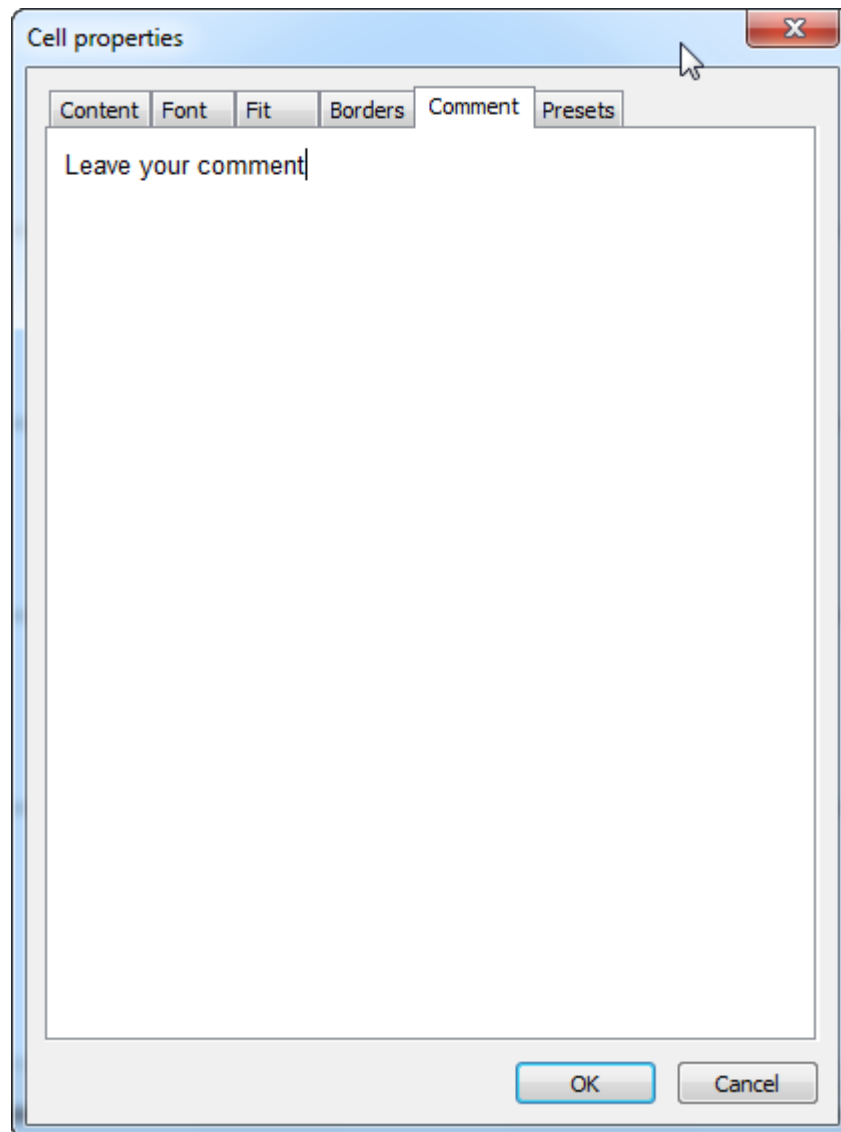

A cell with a comment is displayed with a green label in the editor and when moving the cursor over it the comment is shown.

	A	B	C	D	E
1	15		+		
2	1	2	Leave your comment		5
3					

- In the **Presets** tab you can specify the style for a cell.

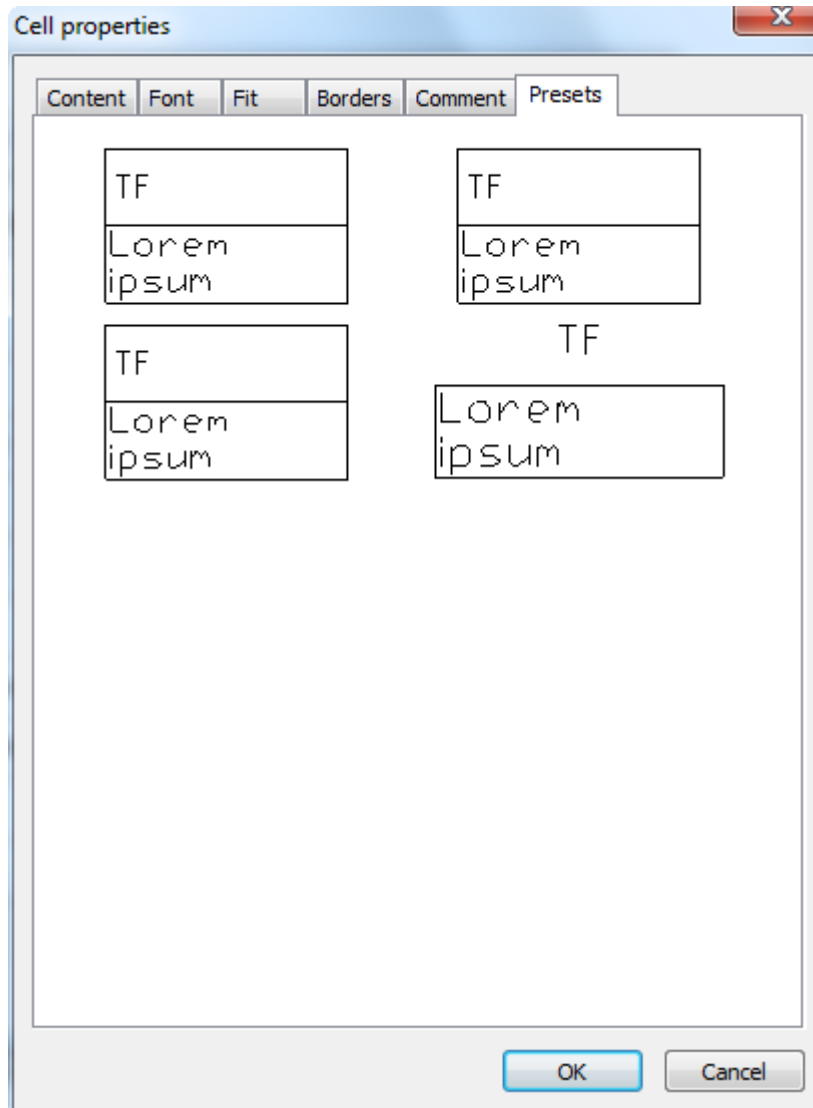

To create a style, click on an empty space on the **Presets** tab and from the context menu select **Create**.

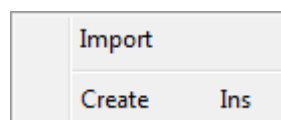

To work with style templates, open the context menu of a style.

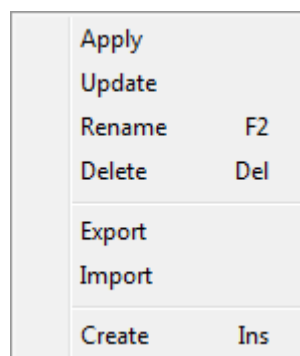

### ***Snap to cell***

In every cell formula you can use other object properties. If automatic table recalculation is switched on, the object formula is automatically recalculated when the object is changed. You can attach one or several objects to every cell. Objects have names: Object1, Object2, Object3 ... There is continuous numbering in the table. If an object is not used in any formulas, it is

detached from the table during the following recalculations and the object references are renumbered.

To snap object properties to a specified cell, use **Expression** from the right-button menu or press the key combination **SHIFT** + **F2**

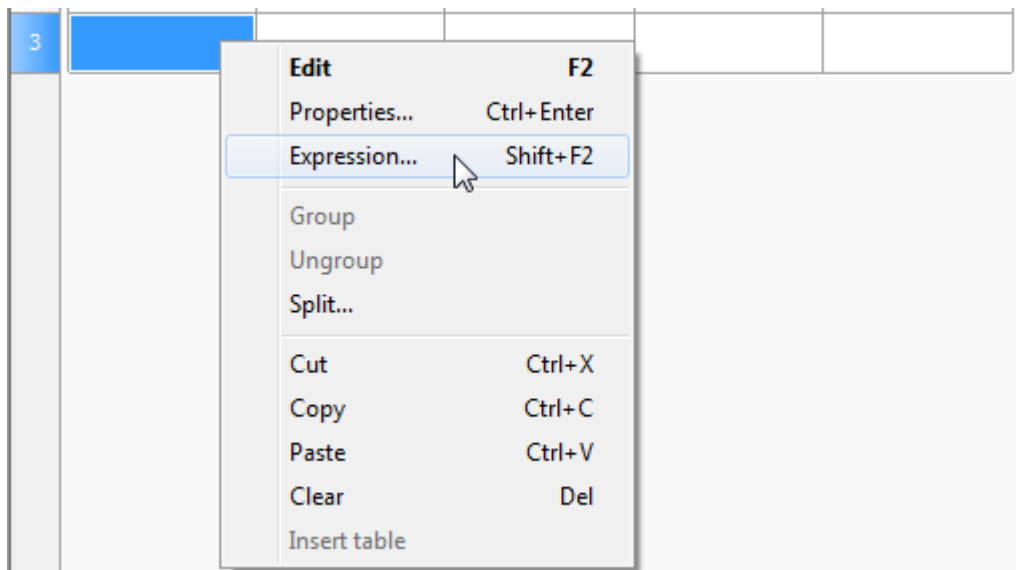

The **Expression builder** dialog box opens

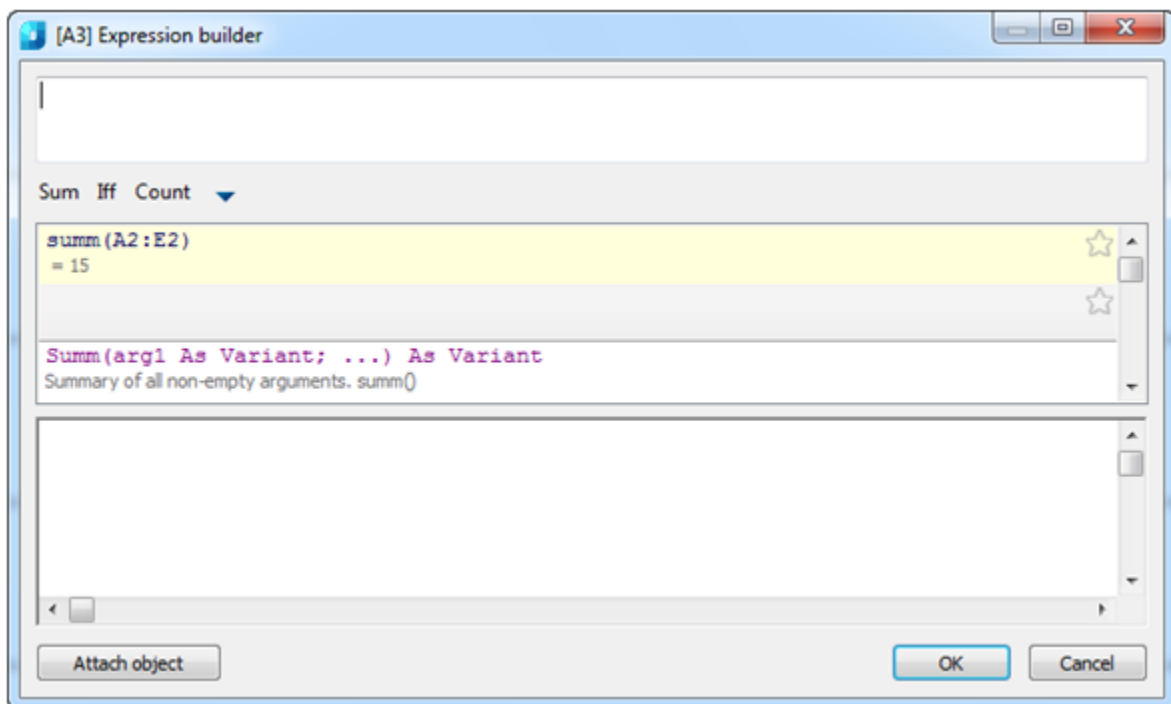

Click the **Attach object** button.

Select the object whose properties you want to snap to the cell. In the properties list you will see the selected object's properties. Double-click it and the property will be added to the cell field. Click **OK**.

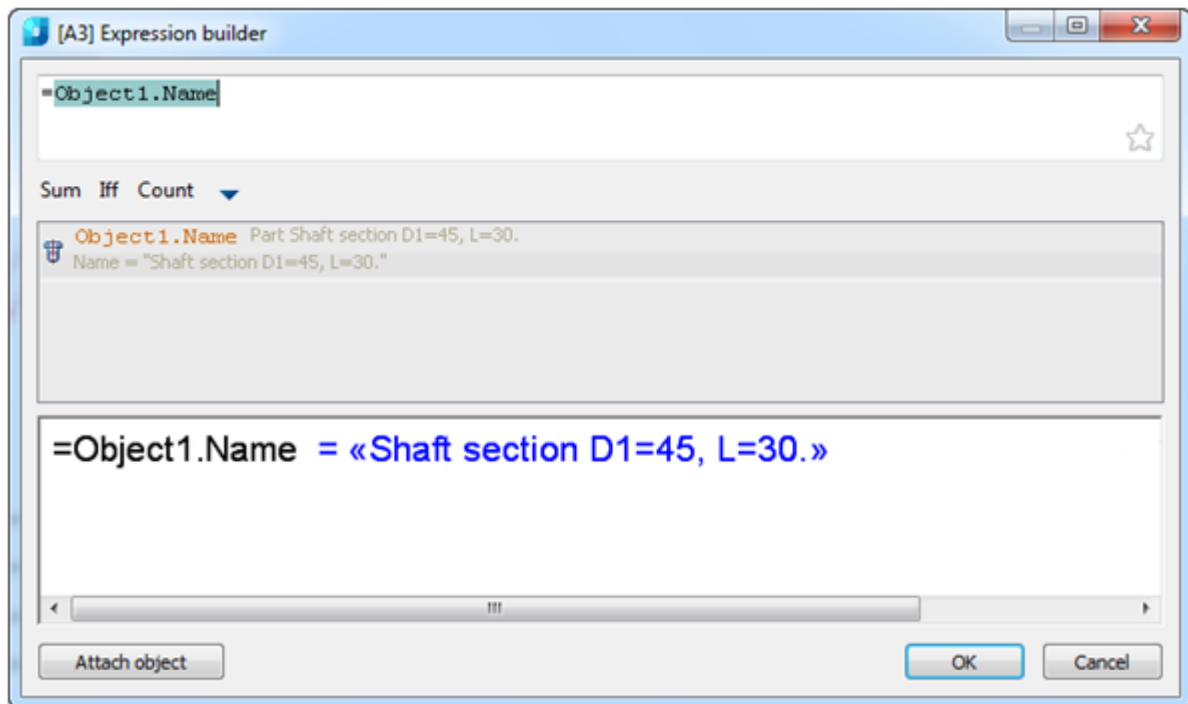

After the object is attached to the cell, the cell color is changed (it means that there is a formula in the cell) and the calculated result will be displayed:



## Expression Builder Interface

With expression builder you can specify parameters, arithmetic expressions and references to object properties for the selected cell.

You can open expression builder for a table cell and for the **Attach object** dialog box. Press **SHIFT** + **F2** to open the dialog box.

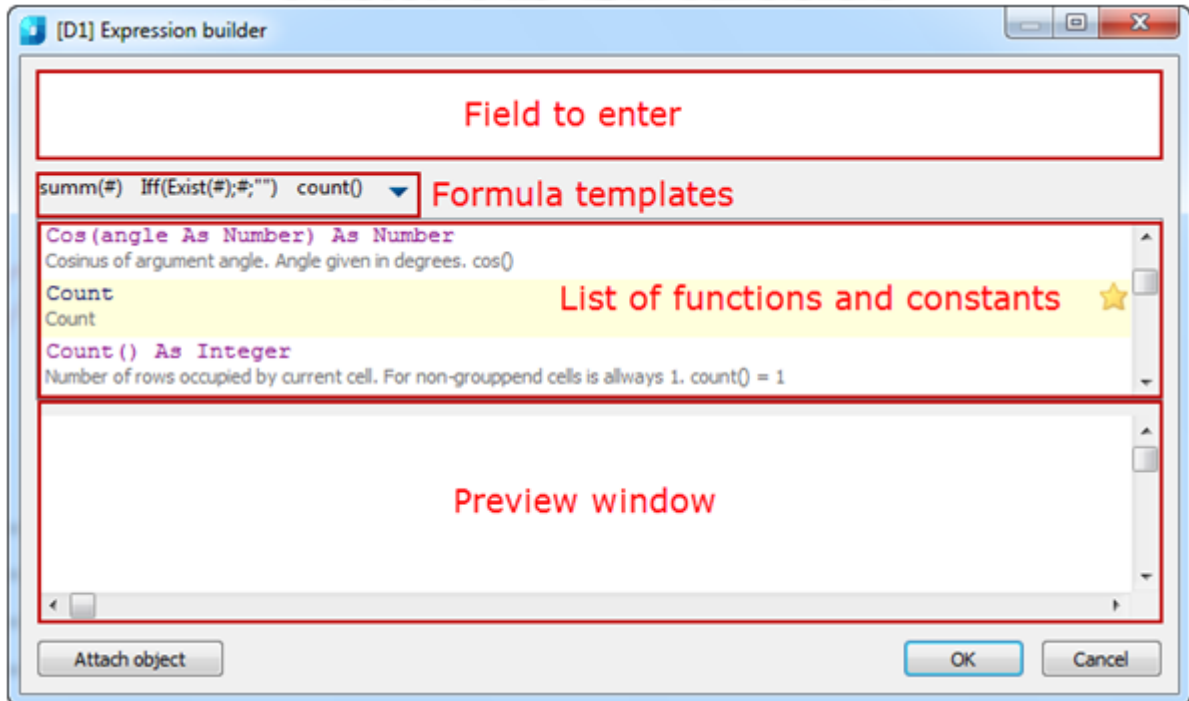
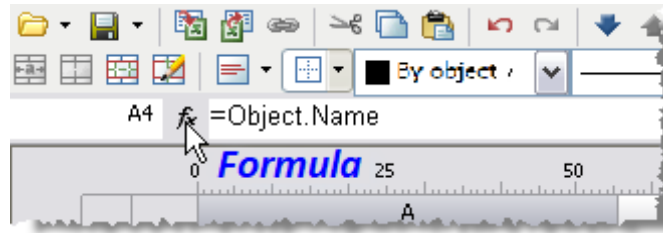

In the top part of the dialog box there is a field to enter any arithmetic expressions and use any constants and object properties.

During input, in the list of functions and constants, all items containing input are displayed. If the input is incorrect, a message about the error or a tooltip will be displayed.

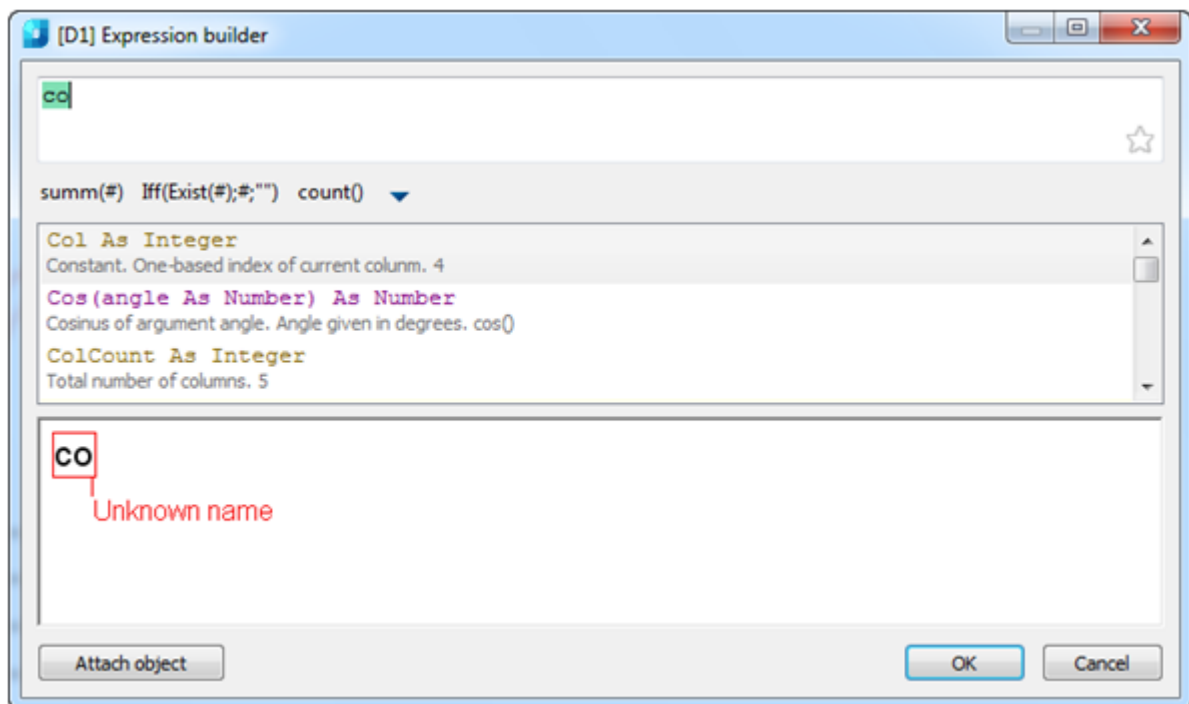

Click in the preview and the expression in the input field will be selected.

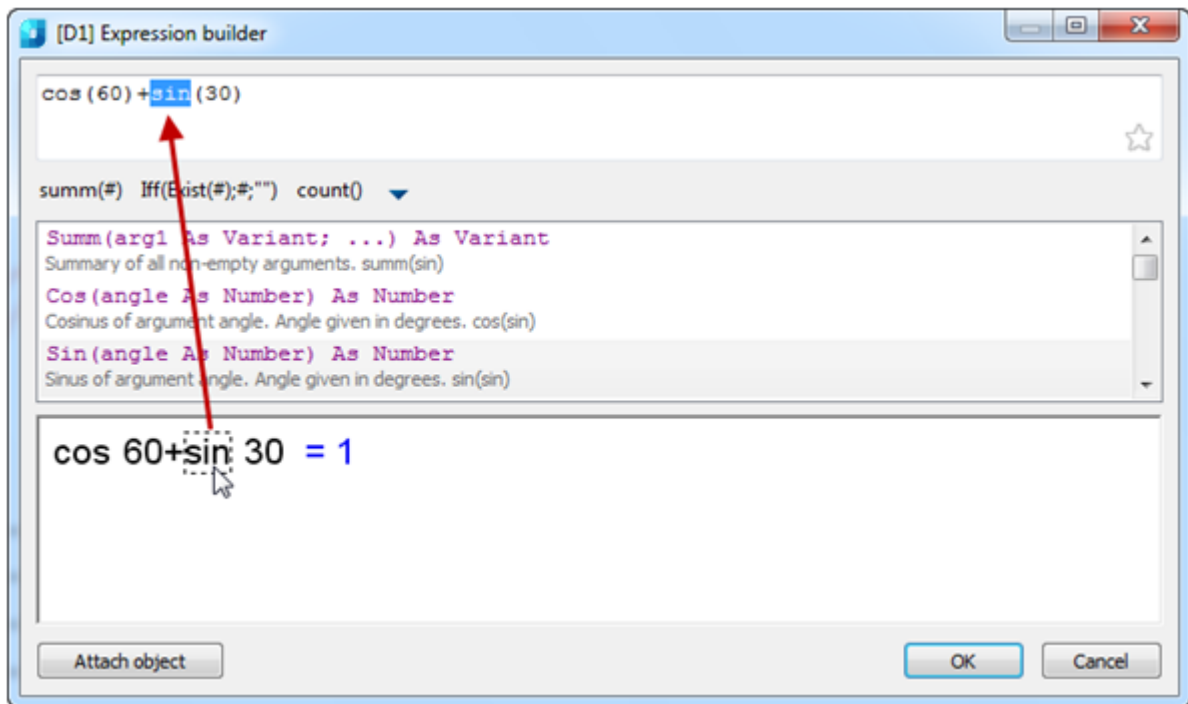

Press the  button and the entered expression will be saved on the template formula bar.

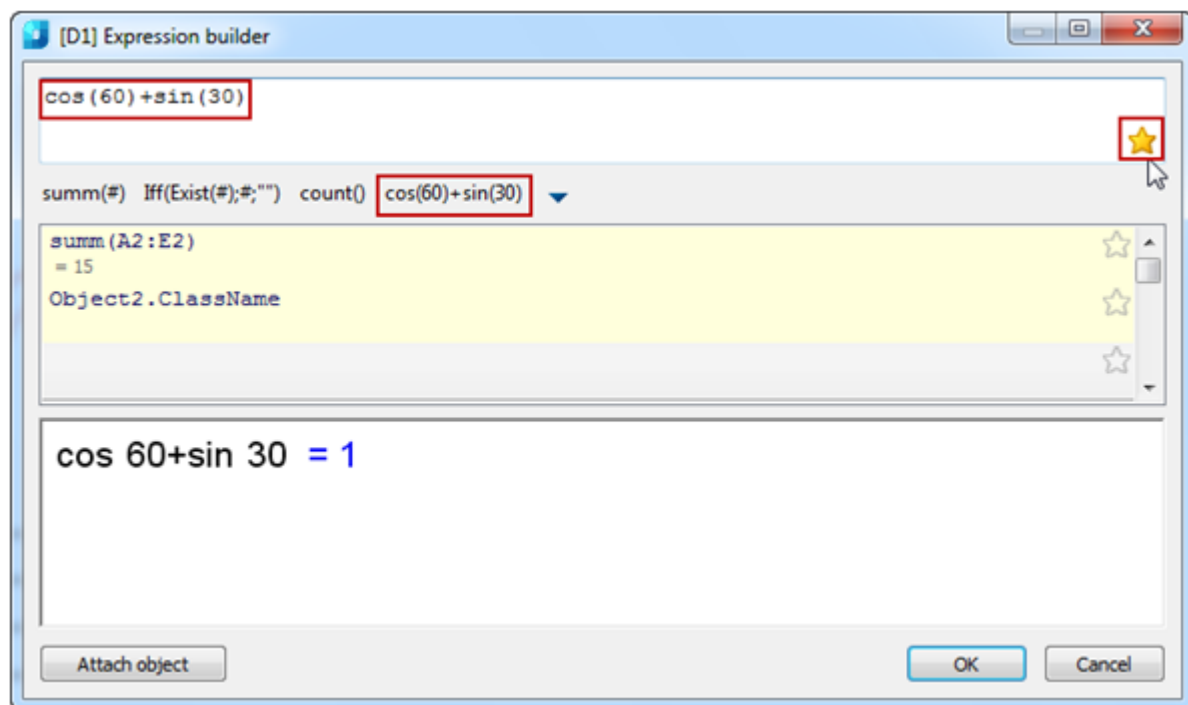

Expressions from the formula template bar are marked with a star in the list of functions and constraints.

### Formula Templates

These allow expressions to be saved in templates for further use.

To save an expression, type it in the field and select the  button. The expression's button will be displayed in the templates list.

There is a tooltip when you move the cursor over the item.

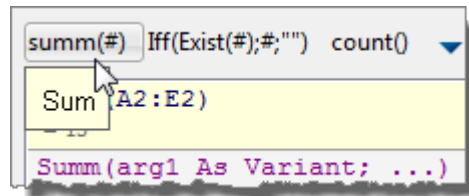

To insert a template, select the button of the saved template.

To delete a template, press the *Alt* button and drag the template button outside the **Expression builder** dialog box

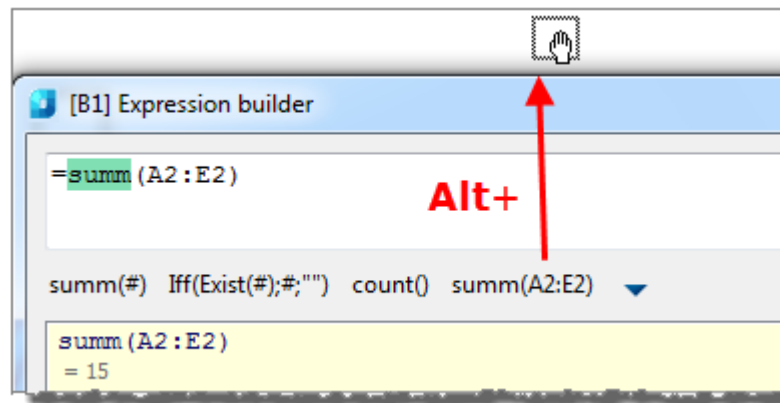

If there are "\$" symbols in the template, after insertion they are changed to the selected text. For example, we create the *Iff(Exist(\$);\$;\"*

### Snap to objects

- opens the **Attach object** dialog box.

### Functions in the Expression Builder

Mathematical operations:

- +** Addition
- Subtraction
- \*** Multiplication
- /** Division
- ^** Raising to the power
- sqrt()** Square-root generation

Logical operations:

- ==** equals
- >** more
- <** less
- !** nor
- |** or
- !=** not equals
- >=** not less
- <=** not more

|| or  
&& and

### Functions:

#### Mathematical:

<b>Cos, Sin, Tg</b>	- Trigonometric function; argument is specified in degrees.
<b>Acos, Asin, Atg</b>	- Arc trigonometric functions, the result received in degrees.
<b>Abs</b>	- Modulus.
<b>Int</b>	- Rounding of number.
<b>Summ</b>	- Returns the sum of the variables values if the cells are grouped

**NOTE!** When entering a function, pay attention to brackets.

#### For example:

*Summ(Row)* - returns the sum of the numbers of grouped rows.

*Summ(Detal.L)* - returns the sum of the parameter L values of the "Detail" object in grouped rows.

#### Data conversion:

<b>Str</b>	- Data conversion to string type.
<b>Num</b>	- Data conversion to numeric type.
<b>Frm</b>	- Numerical value conversion to string type according to the parameters of the table column.

#### For example:

*Frm(0.001230)* returns *0.0012* string if zero suppression mode and *0,0000* accuracy are set for the column containing the cell.

#### Selection and comparing:

<b>FmtText</b>	- Addition of formatted strings.
<b>FmtSub</b>	- Creation of lower index.
<b>FmtSuper</b>	- Creation of upper index.
<b>FmtDigit</b>	- Number conversion to typesetting form.
<b>FmtRaw</b>	- Not formatted text.
<b>FmtDiv</b>	- Creation of fraction.
<b>If/Iff</b>	- function of logical decision. Format: <i>if(Logical_Condition; If_True; If_False,</i> where: <i>Logical_Condition</i> – logical condition with logical operations for comparing; <i>If_True</i> – returned value, if logical condition is held; <i>If_False</i> - returning value, if logical condition is not held.

#### For example:

*if(object == Marker; Marker.Position; "Not determined").*

If the object type attached to the column cell has a Marker value, the function returns its Position value.



If the object has another type, the *Not determined* value is returned.

**Exist**

Checks the existence of a constant:  
=IF(EXIST(Object.Name);Object.Name;0)

**Min/Max**

- Returns the minimum/maximum value listed in the brackets.

**For example:**

*Min(maximum\_value; minimum\_value)* - returns *minimum\_value*;

*Max(maximum\_value; minimum\_value)* - returns *maximum\_value*.

**Count**

- Returns the number of objects (for grouped rows of a table).

**For example:**

*Count()* - returns number of objects attached to the cells of the grouped rows.

**Avg**

- Calculates arithmetical average of arguments. It can use any number of arguments of any ranges. Null arguments are not used.

**Off**

- Returns a cell value, specified by a relative index. The index format is:

*Off(row; column)*

**For example:**

*Off(-1;2)* - returns the cell value located one row above and two columns to the right of the current cell.

**Cell**

- Returns the cell value specified by an absolute index.

**Merge  
(Cells,Expression)**

- Merges the Cells in a range. If the Expression is not equal to zero, it returns the Expression value.

**For example:**

*=merge(A5:C5; "Name")* - merges cells from A5 to C5 and in the results cell, the "Name" text is displayed.

**SetHeight()**

- Specifies the column height. Height value is specified in brackets.

**Val()**

- Calculated argument.

**For example:**

*=val("A"+"1")* - calculates "A1", and uses it as an expression (value in A1 cell). If argument is not a row, it is returned.

*=val(10+2)* - is the same as *=10+2*.

*=val("summ(A"+Str(off(0;-1))+":D"+Str(off(0;-1))+"))*

- sum of cells from A to D of row, whose number is in the cell to the left of the current one. In general, you can do without val. It is needed when you have to enter a cell address in user form to take the value from it further. Create the Addr variable, attach it to the input field in the form and enter in the table: *=val(Addr)*. Function allows recurrence:

*=val(val("A"+"1"))* - takes its value from the cell whose address is in cell A1. Number of enclosures is limited to 64.

**Geometry(Object)**

- Works as **Attach object** . The height of the attached object is fitted to the cell height. The object is taken from the report and attached to the cell.

- SUMM(Section(-1))** - Sum of the current column's cells in the section, following after the current section.
- COUNT(Section(A3))** - Number of rows in the section containing cell A3.

**Reserved variables:**

- Pi** - Pi character.
- Row** - Returns the row number for every cell (rows are numbered from 1, the header row is not numbered).
- Col** - Returns the column number for every cell (column "A" is number 1).
- Object** - Returns the object type, attached to row cells.
- Object1, Object2, ...** - Objects attached to the cell.
- Title** - Table name.
- RowCount** - General number of rows.
- ColCount** - General number of columns.

## Report Creation

Reports are used to arrange information about objects in the drawing.

To create a report, select **Insert Report section** from the **Section** menu in the table editor.

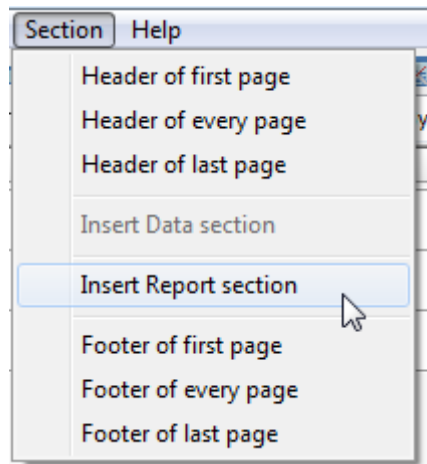

A report consists of two sections: **Report template** and **Report**.

The report template defines how the content is displayed in the report and can contain one or several lines. A copy of the template rows is created for every object. Formulas are calculated according to the properties of the selected objects.

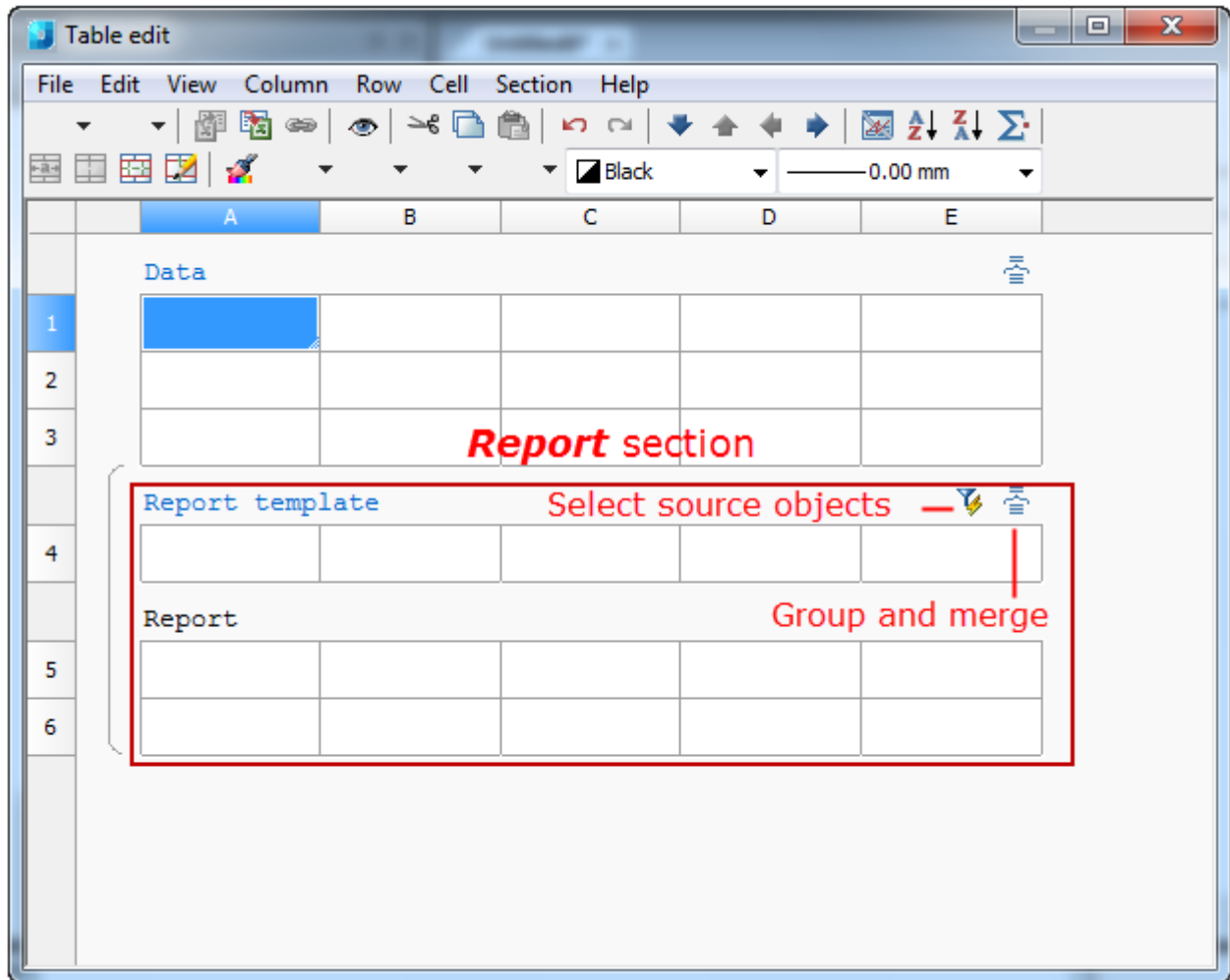

The report template contains the variables of the selected objects; the values of the template variables are displayed in the report.

Using the **Select source objects**  tool you can select inserted objects according to the required conditions.

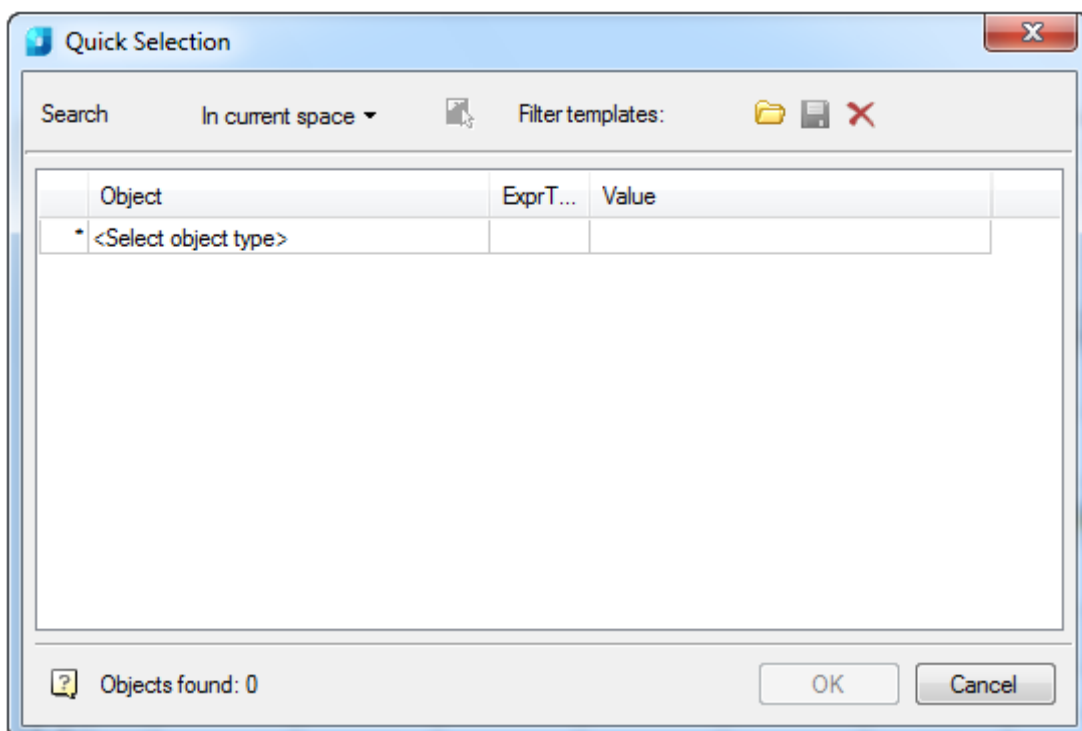

In the **Grouping and merging**  dialog box you can specify the settings for grouping and merging table cells.

**Report template** menu:

- **Report header** adds a report header row to the beginning of the report;
- **Report footer** adds a report summary row to the end of the report;

	A	B	C	D	E
	Report template 				
4					
5					
	Report				
6					
7					
8					
9					
10					
11					
12					
13					
	Report summary				
15					

Context menu of the **Report summary** cells:

Sum
Average
Minimum
Maximum
Count

The action applied to the column fragment in one section.

**Vertical grouping**

A report template can contain several lines. Cells with identical values can be merged. From the right-button menu select **Insert row** or **Add row**.

Add row
Insert row
Delete row
Hide row
Show hidden rows
Start new page

	Report template		
4	Insert row		
5	=Object.Name	=Object.L	=Object.p
6	Add row		

When adding a row, it is added after the selected row, but when inserting a row, it is added before selected row.

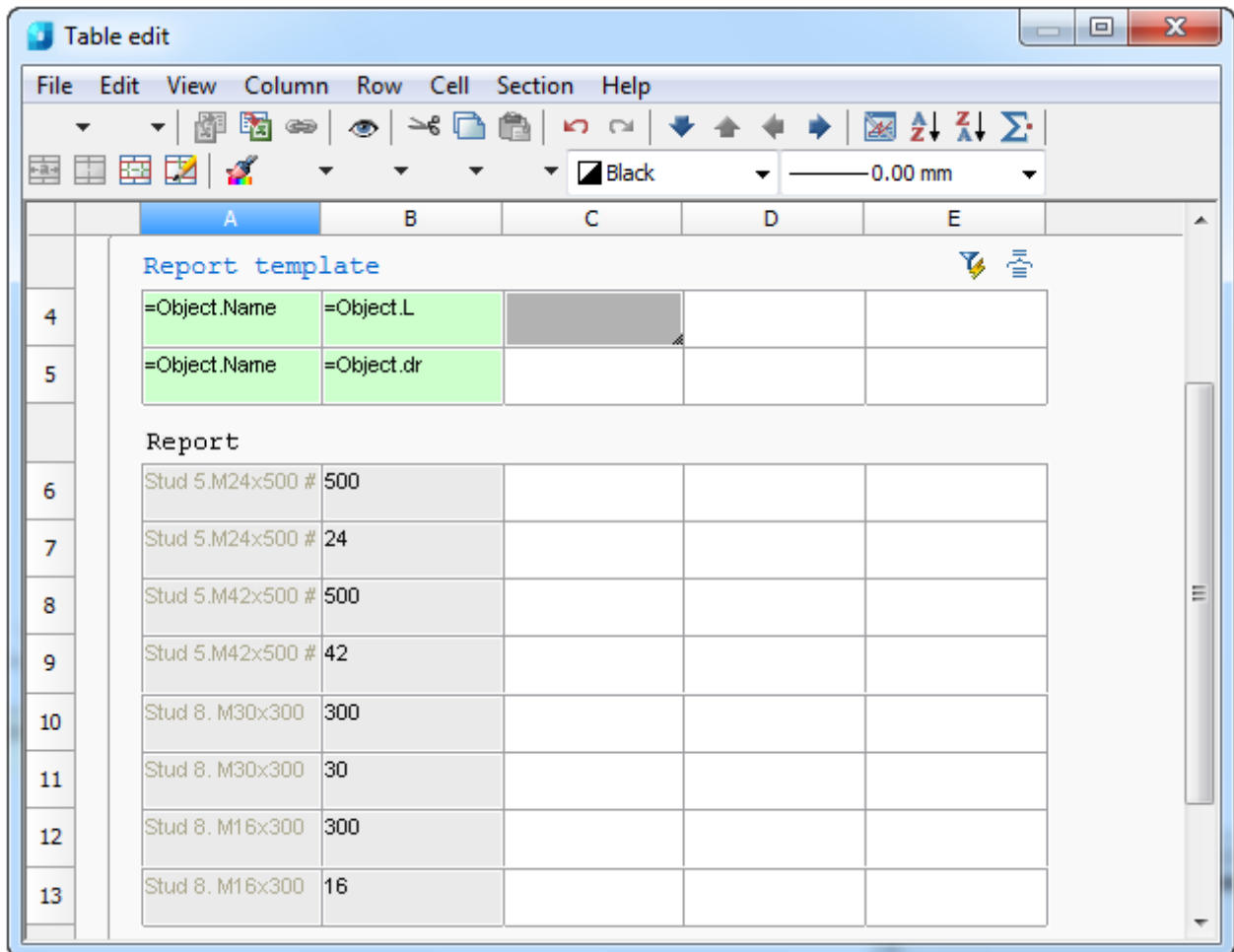

Setting variables for rows. Select A4 and A5 cells and from the right-button menu select **Group**.

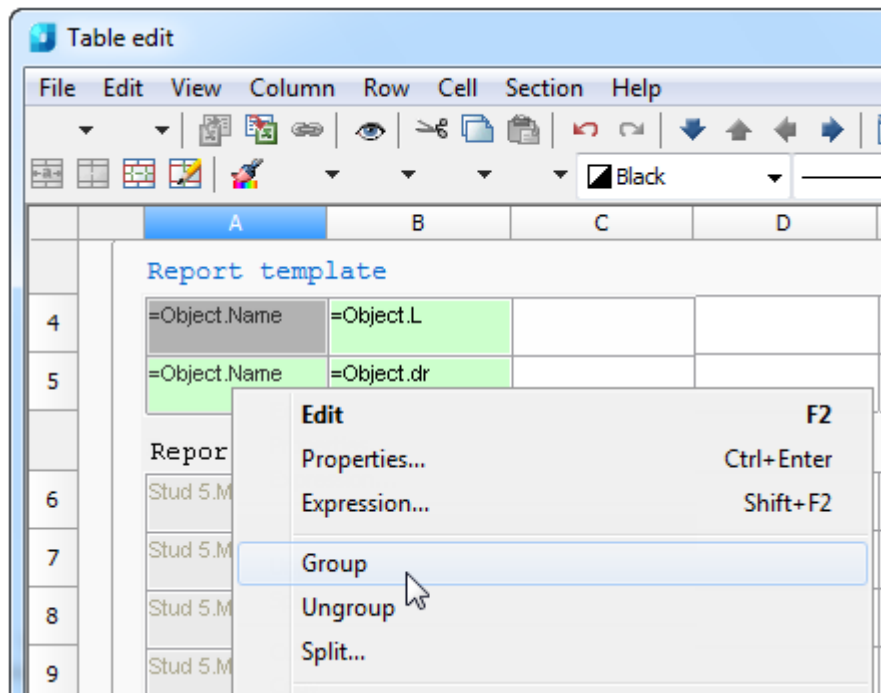

The selected cells will be grouped. The table will be displayed as follows:

<i>Stud 5.M24x500 # GOST 24379. 1-80</i>	500
	24
<i>Stud 5.M42x500 # GOST 24379. 1-80</i>	500
	42
<i>Stud 8. M30x300 # GOST 24379.1- 80</i>	300
	30
<i>Stud 8. M16x300 # GOST 24379.1- 80</i>	300
	16

There are cells in the report highlighted with special colors.

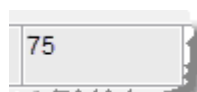

If you edit such cells, changes are applied to the object to which they belong.

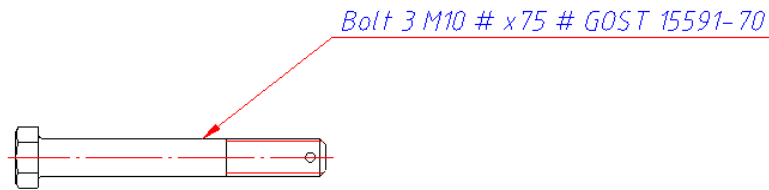

Create a table and report template.

Add the parameters: **=Object.Name** and **=Object.L**.

A	B	C
Report template		
=Object.Name	=Object.L	
Report		
Bolt 3 M10 # x75	75	

Enter a new length, for example 120.

A	B	C
Report template		
=Object.Name	=Object.L	
Report		
Bolt 3 M10 # x120	120	

The bolt's length is changed.

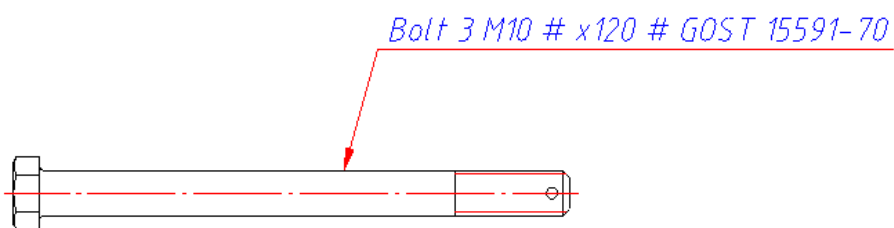

## Grouping and Merging Cells

**Group and merge**  **button.** Report template.

In the **Grouping and merging** dialog box you can specify settings for grouping and merging table cells. Grouping and merging are only applied to cells in the report template.

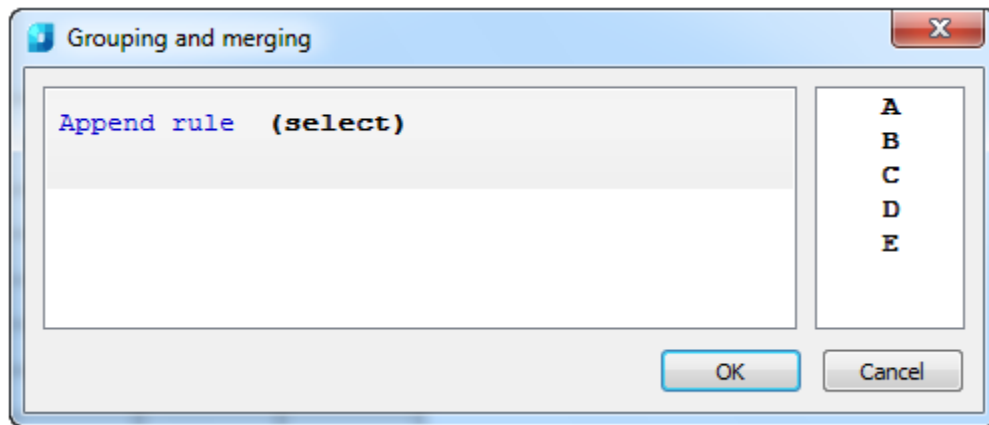

Study the example for how to merge cells.

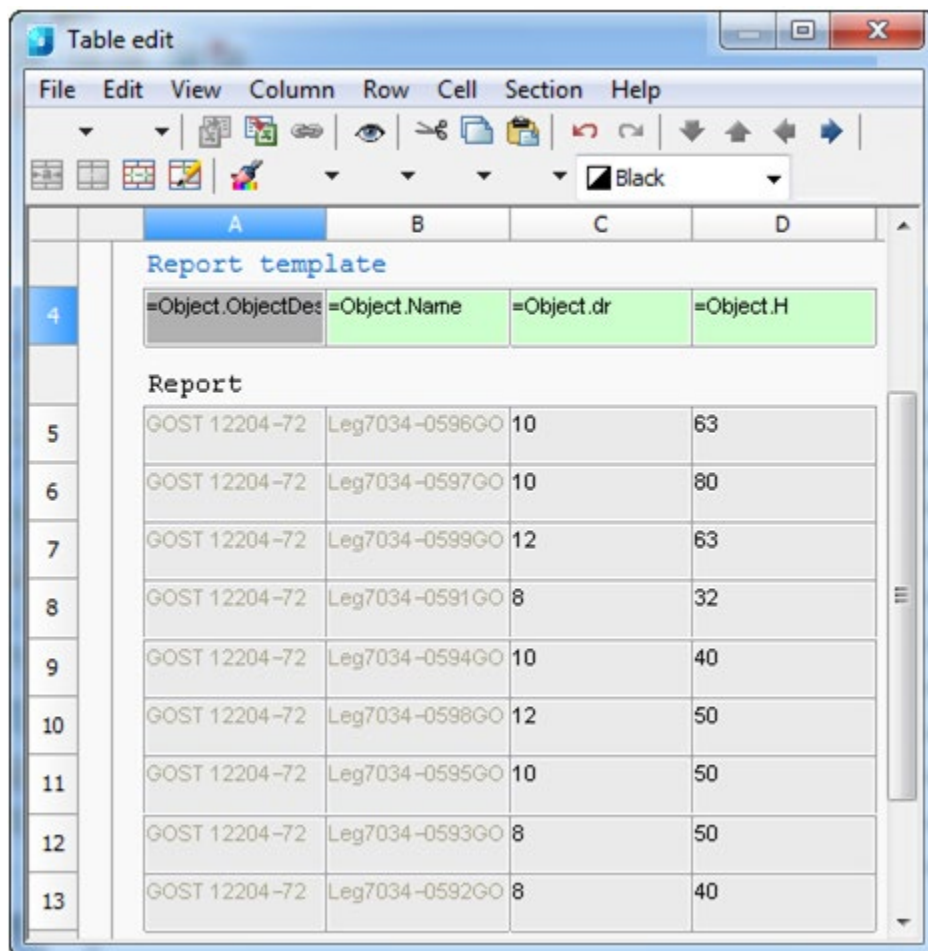

	A	B	C	D
	<b>Report template</b>			
4	=Object.ObjectDes	=Object.Name	=Object.dr	=Object.H
	<b>Report</b>			
5	GOST 12204-72	Leg7034-0596GO	10	63
6	GOST 12204-72	Leg7034-0597GO	10	80
7	GOST 12204-72	Leg7034-0599GO	12	63
8	GOST 12204-72	Leg7034-0591GO	8	32
9	GOST 12204-72	Leg7034-0594GO	10	40
10	GOST 12204-72	Leg7034-0598GO	12	50
11	GOST 12204-72	Leg7034-0595GO	10	50
12	GOST 12204-72	Leg7034-0593GO	8	50
13	GOST 12204-72	Leg7034-0592GO	8	40



GOST 12204-72	Leg7034-0596GOST 12204-72	10	63
GOST 12204-72	Leg7034-0597GOST 12204-72	10	80
GOST 12204-72	Leg7034-0599GOST 12204-72	12	63
GOST 12204-72	Leg7034-0591GOST 12204-72	8	32
GOST 12204-72	Leg7034-0594GOST 12204-72	10	40
GOST 12204-72	Leg7034-0598GOST 12204-72	12	50
GOST 12204-72	Leg7034-0595GOST 12204-72	10	50
GOST 12204-72	Leg7034-0593GOST 12204-72	8	50
GOST 12204-72	Leg7034-0592GOST 12204-72	8	40

### Merging

1. In the **Grouping and merging** dialog box select **Append rule** and select **Merge**.

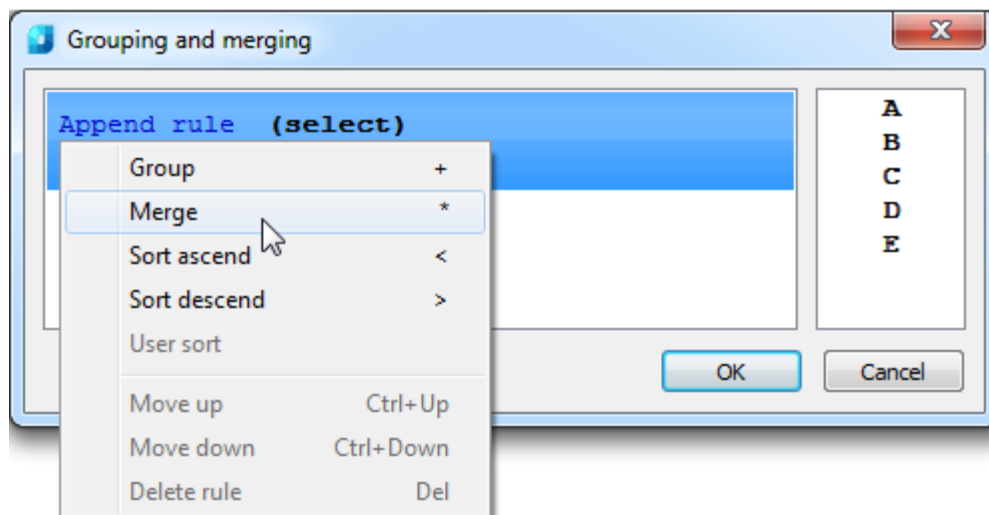

2. Select the column name for the cells you want to merge. Selection is made by double clicking on the column name or by dragging it into the **Select** field.

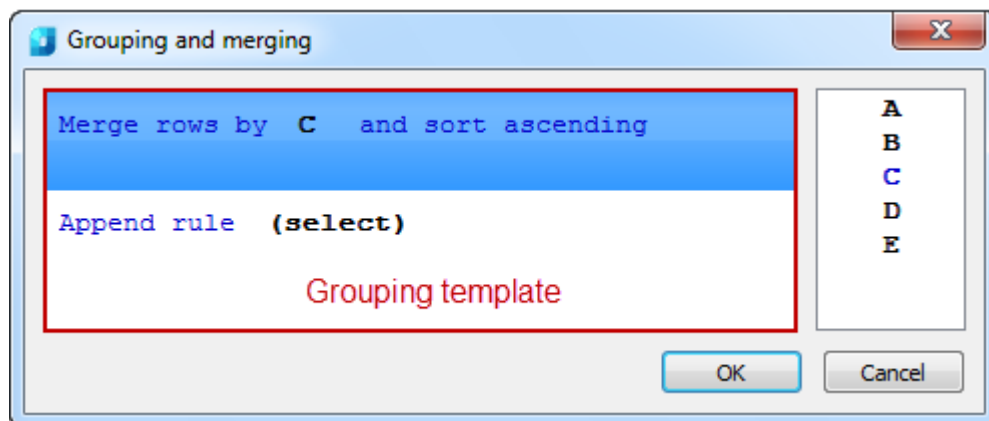

**NOTE!** To select another column, you should drag it into the column list and then select it. You can select several columns then place them in the required order.

The columns are processed according to the rules of the **grouping template**.

3. If you want to sort, select and **don't sort** and select sort type.

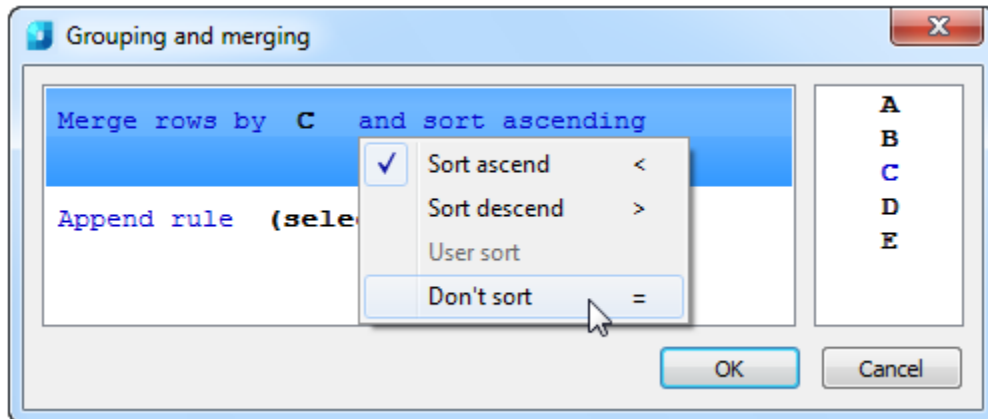

4. Click **OK** to check the result in the table editor. Cells having identical values in the D column will be merged.

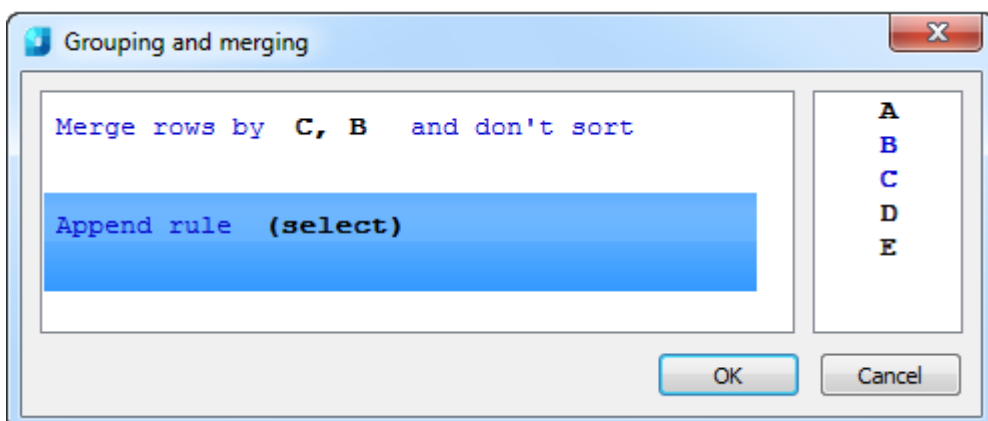
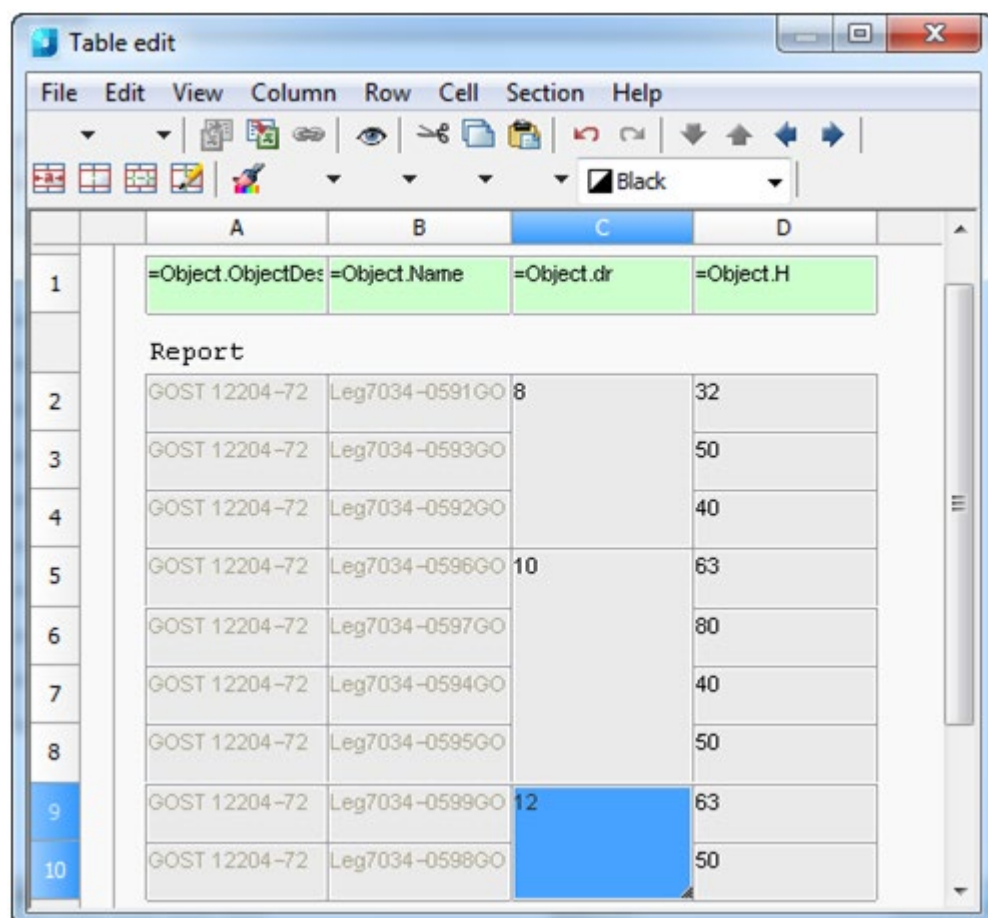

Rows, which have identical values in B and in C columns, are merged. The order of specifying columns is unimportant.

Name	Description	Thread diameter	Length	Diameter
Leg7034-0591GOST 12204-72	GOST 12204-72	8	32	12
Leg7034-0592GOST 12204-72			40	
Leg7034-0593GOST 12204-72			50	
Leg7034-0594GOST 12204-72	GOST 12204-72	10	40	14
Leg7034-0595GOST 12204-72			50	
Leg7034-0596GOST 12204-72			63	16
Leg7034-0597GOST 12204-72			80	
Leg7034-0599GOST 12204-72	GOST 12204-72	12	63	18
Leg7034-0598GOST 12204-72			50	

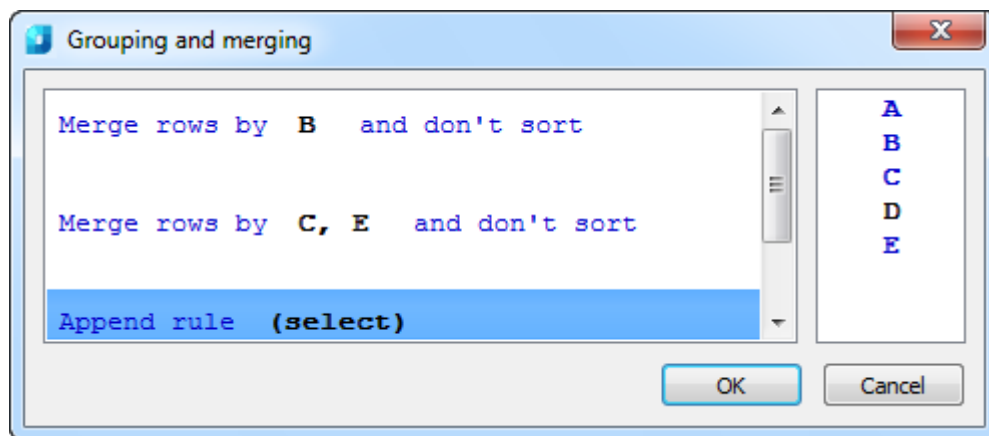

Rows, which have identical values in B are merged, then cells in C and E are merged. The order of specifying columns is unimportant.

Name	Description	Thread diameter	Length	Diameter
Leg7034-0591GOST 12204-72	GOST 12204-72	8	32	12
Leg7034-0592GOST 12204-72			40	
Leg7034-0593GOST 12204-72			50	
Leg7034-0594GOST 12204-72	GOST 12204-72	10	40	14
Leg7034-0595GOST 12204-72			50	
Leg7034-0596GOST 12204-72	GOST 12204-72	10	63	16
Leg7034-0597GOST 12204-72			80	
Leg7034-0599GOST 12204-72	GOST 12204-72	12	63	18
Leg7034-0598GOST 12204-72			50	

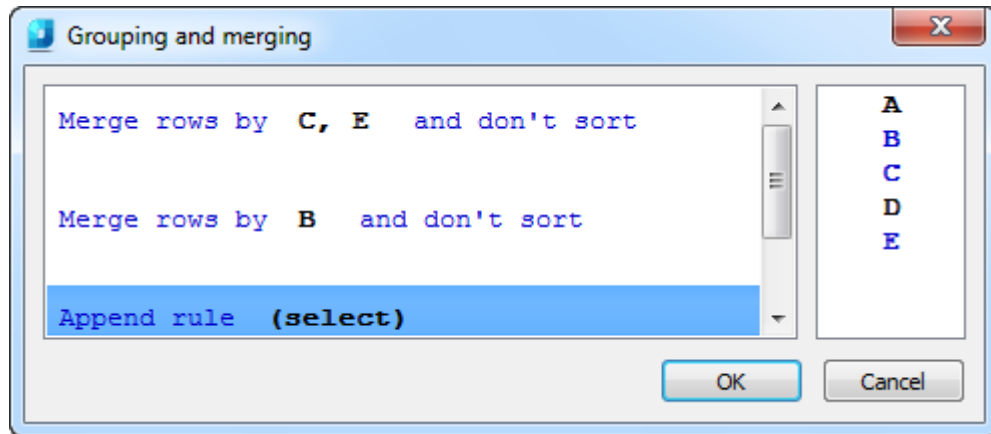

Rows, which have identical values in C, are merged, and then cells in E and B are merged. The order of specifying columns is unimportant.

Name	Description	Thread diameter	Length	Diameter
Leg7034-0591GOST 12204-72	GOST 12204-72	8	32	12
Leg7034-0592GOST 12204-72			40	
Leg7034-0593GOST 12204-72			50	
Leg7034-0594GOST 12204-72	GOST 12204-72	10	40	14
Leg7034-0595GOST 12204-72			50	
Leg7034-0596GOST 12204-72	GOST 12204-72	10	63	16
Leg7034-0597GOST 12204-72			80	
Leg7034-0599GOST 12204-72	GOST 12204-72	12	63	18
Leg7034-0598GOST 12204-72			50	

### Grouping

1. In the **Grouping and merging** dialog box select **Append rule** and select **Group**.

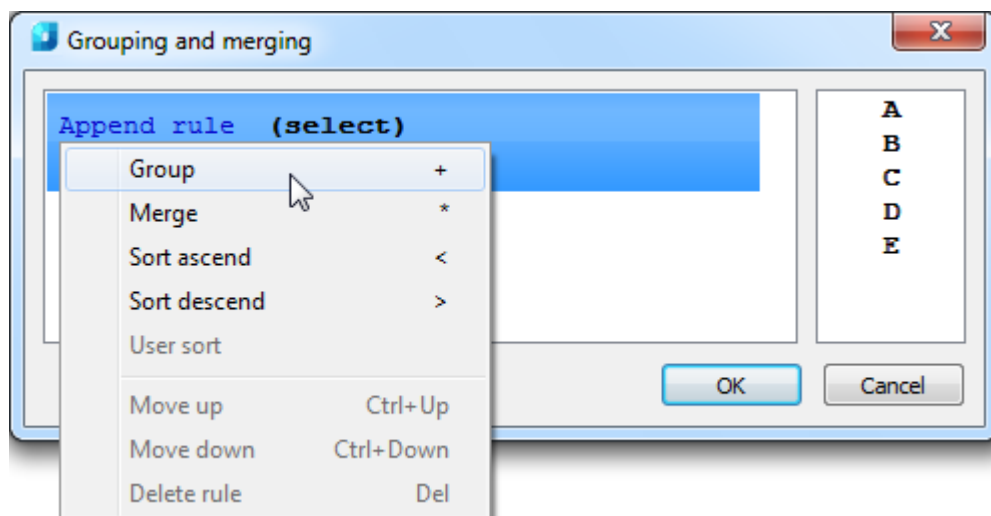

2. Select the column name of the cells you want to group. Selection is made by double clicking on the column name or by dragging it into the **Select** field.

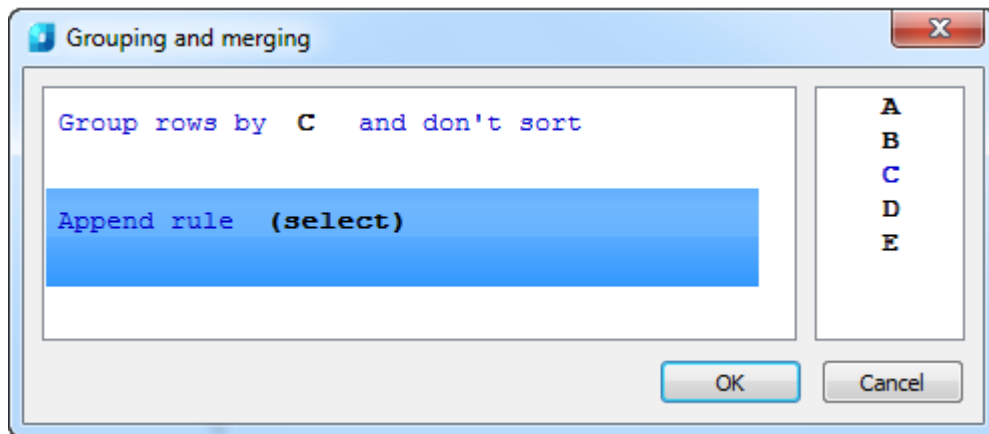

3. If you want to sort, select and **don't sort** and select a sort type.
4. Click **OK** to check the result in the table editor. Cells having identical values in the C column will be grouped.

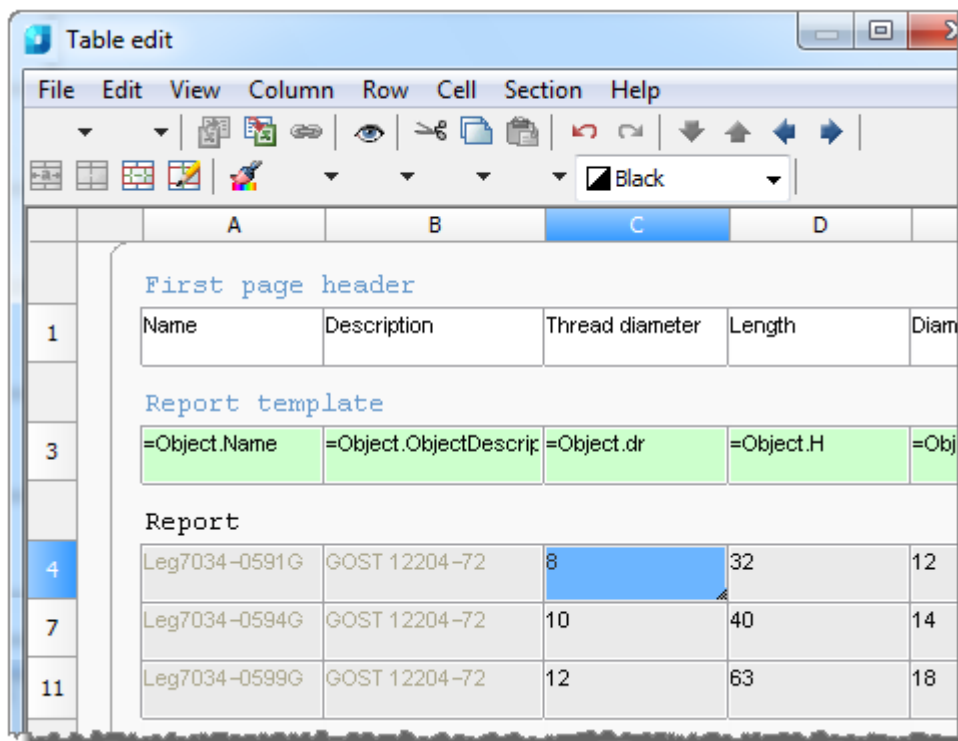

## Insert Material







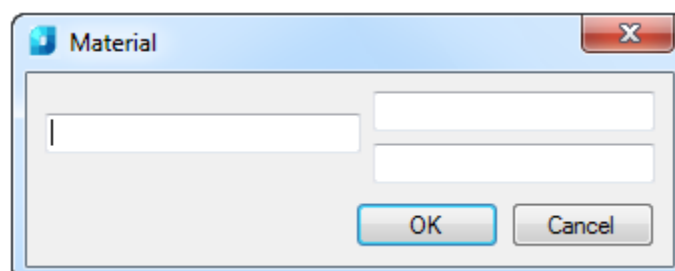



Button: **Insert material** – 

Use this tool to insert formatted rows of material in the table. Click the icon to open the **Material** dialog box:



# .dwg Tables

## Inserting .dwg Tables

-  Ribbon: **Annotate – Tables** –  .dwg Table
-  Menu: **Draw – Tables** >  **Tables .dwg...**
-  Toolbar: **Draw** – 
-  Toolbar: **Tables** – 
-  Command line: **DTABLE**

Inserting an empty table into a drawing.

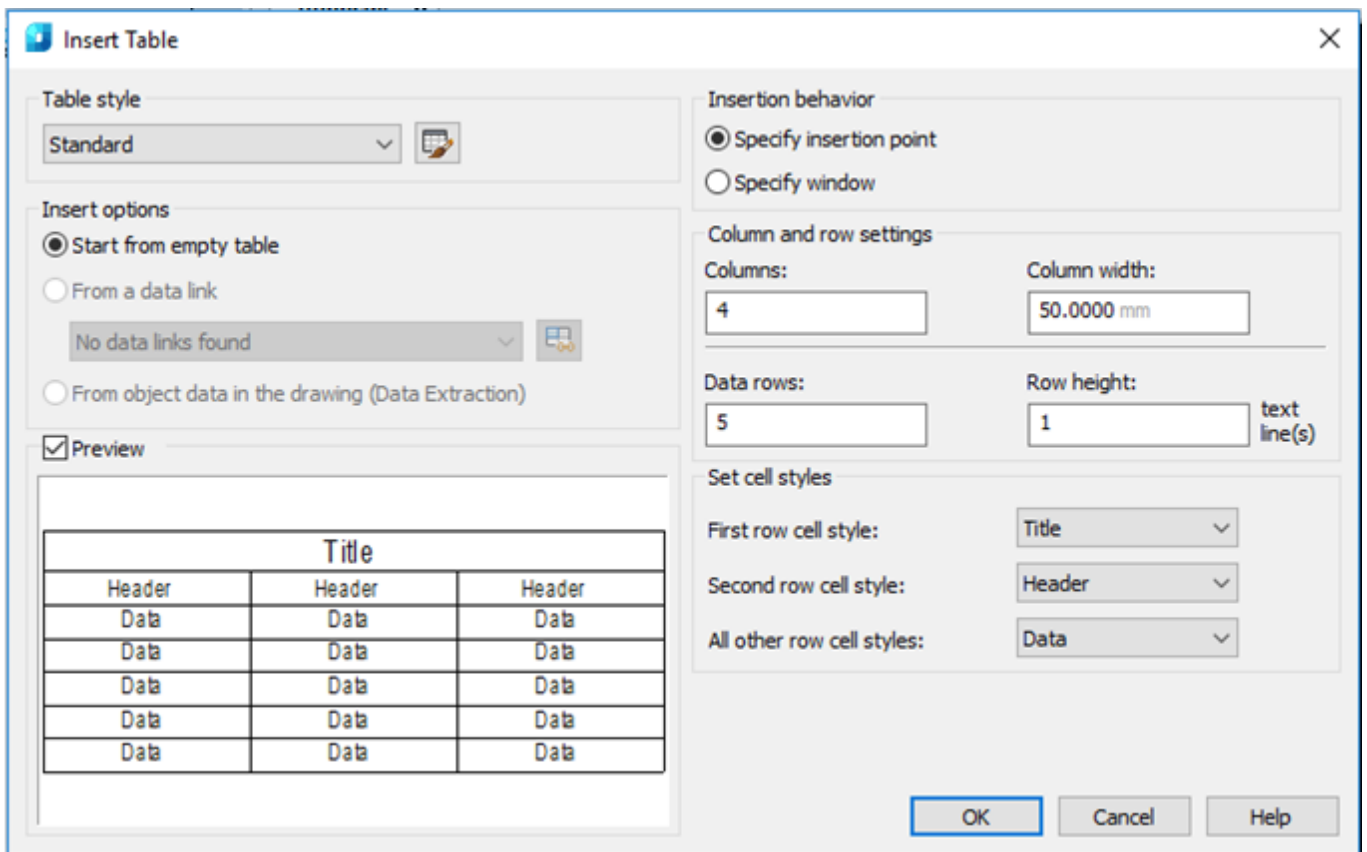

### Parameters:

#### Table style

In the current drawing select the table style based on which it is required to create a table. You can create a new table style by clicking the button next to the drop-down list.

#### Insert options

Specifies the way to insert a table.

**Start from empty table**

Creates an empty table that can be filled with data manually.

*Preview*

Manages the display of preview sample. If the table is empty, the sample is the example of the table style. When connected with the table, the sample corresponds to the obtained table. When working with large tables to increase the performance, the checkbox can be deselected.

*Insertion behavior*

Specifying a table location.

**Specify insertion point**

Specifies the location of the left upper corner of the table. It is possible to use picking device or enter coordinates in the command line. If the table style determines the table construction direction from bottom up, the insertion point corresponds to the left lower corner of the table.

**Specify window**

Specifies size and location of the table. You can use picking device or enter coordinates in the command line. When selecting this option the number of columns and rows, as well as column width and row height depend on the frame size, as well as on column and row settings.

*Column and row settings*

Specifies the number of size of columns and rows.

**Columns**

Specifies the number of columns. When selecting **Specify window** option and setting column width, the **Auto** parameter is enabled and the number of columns is calculated in accordance with the table width. If the table style containing the original table is specified, it is possible to select the number of additional columns to be added to this original table.

**Column width**

Specifies the column width in the table. When selecting **Specify window** option and setting the number of columns, the **Auto** parameter is enabled and the column width is calculated in accordance with the table width. The minimum column width is one printed character.

**Data rows**

Specifies the number of rows. When selecting **Specify window** option and setting row height, the **Auto** parameter is enabled and the number of rows is calculated in accordance with the table height. Table style with a title row and a header row determines the table containing at least three rows. The minimum row height is equal to one text line. If the table style containing the original table is specified, it is possible to select the number of additional data rows to be added to this original table.

**Row height**







Specifies the row height in the text lines. Text line height depends on the text height and space from cell borders; these parameters are set in the table style. When selecting **Specify window** option and setting the number of rows, the **Auto** parameter is enabled and the row height is calculated in accordance with the table height.

### Setting cell styles

Applies to styles of tables not containing the original table; determines cell style for rows of the new table.

<b>First row cell style</b>	Determines cell style for the first row in the table. By default, the <b>Name</b> cell style is applied.
<b>Second row cell style</b>	Determines cell style for the second row in the table. By default, the <b>Column</b> cell style is applied.
<b>All other row cell styles</b>	Determines cell style for all other row in the table. By default, the <b>Data</b> cell style is applied.

## Table Styles .dwg

-  Ribbon: **Annotate – Tables –** 
-  Menu: **Format >**  **Table styles...**
-  Dialog **Insert table:** 
-  Command line: **DTABLESTYLE**

The command opens the **Table style** dialog box, in which you can create and change styles of .dwg tables.

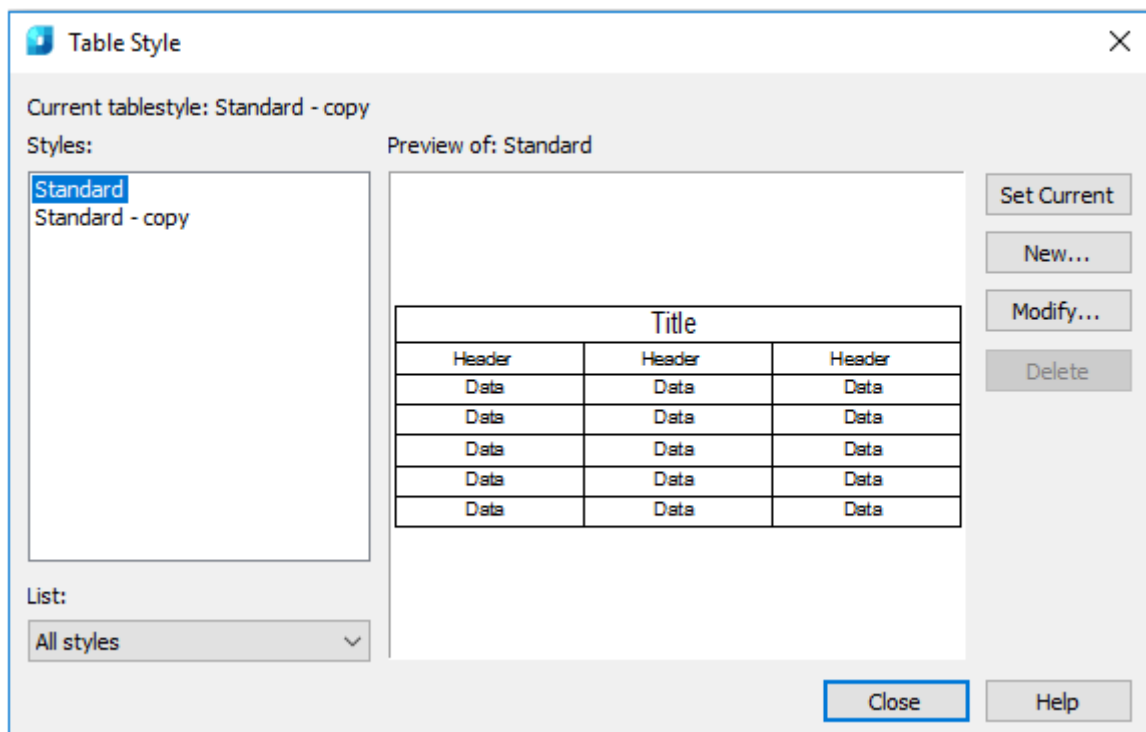

### Options:

<b>Styles</b>	List of styles of .dwg tables in the document. It's content is regulated by the <b>List</b> drop-down list.
<b>List</b>	Determines what styles should be displayed in the <b>Styles</b> list: all styles or only styles in use.



**Preview of**

Preview window that displays an assumed view of the table created using style selected in the **Styles** list.

**Set current**

Makes current the style selected in the **Styles** field.

**New**

Opens the **Create New Table Style** dialog box to create a new style based on that selected in the **Styles** field.

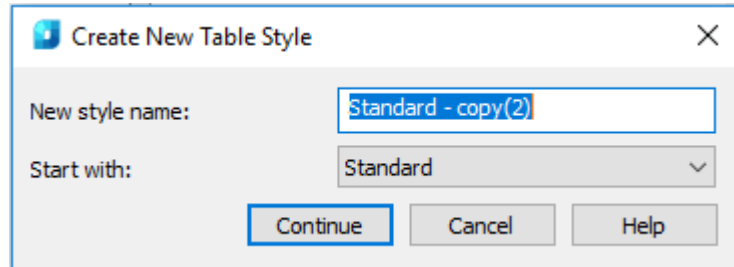

Clicking the **Continue** button opens the **Modify Table Style** dialog box as described below.

**Modify**

Opens the **Modify Table Style** dialog box to edit the style selected in the **Styles** field.

**Delete**

Deletes the style selected in the **Styles** field.

To rename the style, double-click it in the **Styles** list.

## Modifying Table Style

The **Modify Table Style** dialog box opens when editing the current or creating a new style.

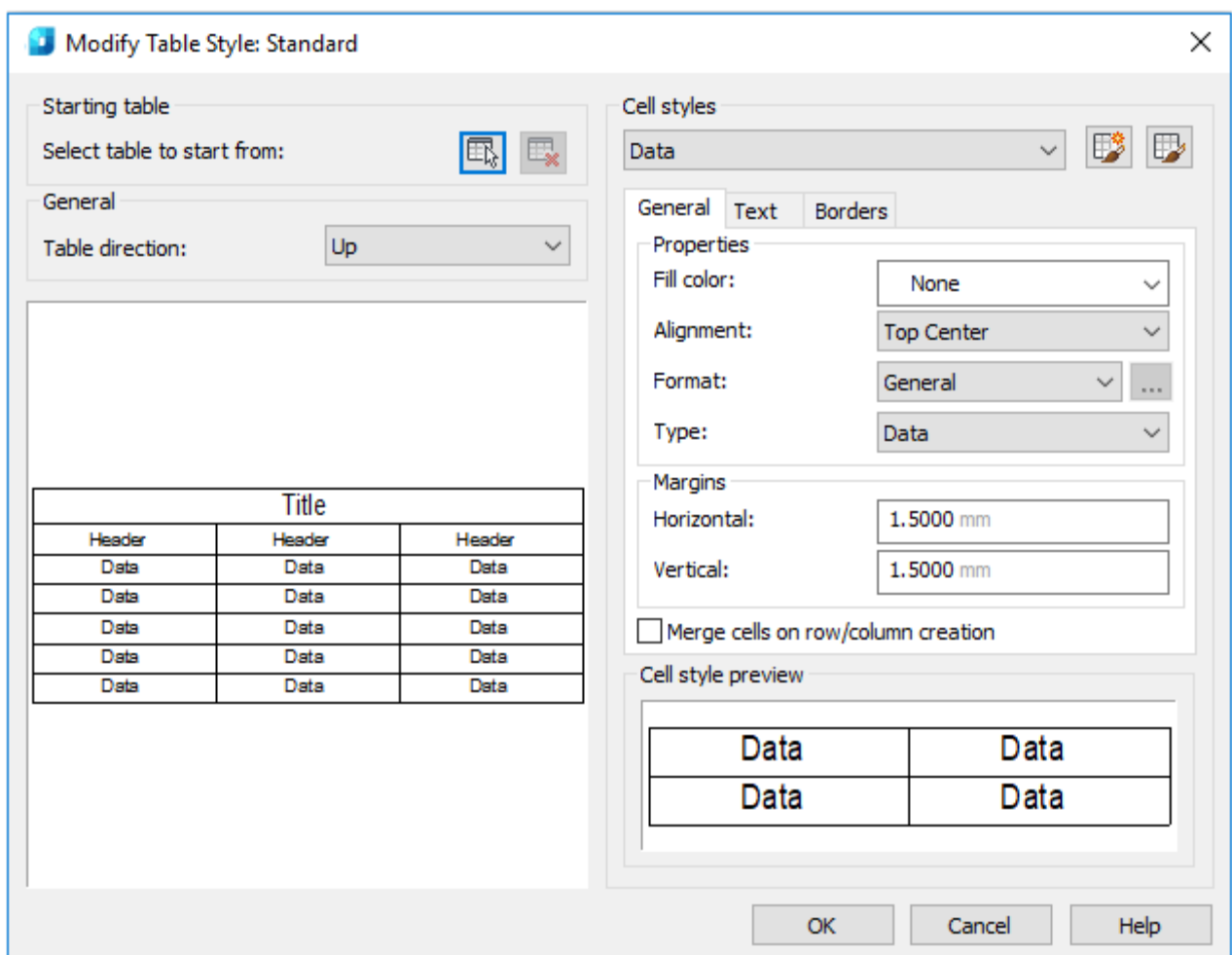

### Options:

#### Select table to start from

Selects the table on the drawing to use as a sample when forming this table style. In the current software version the function is not realized.

#### Table direction

Sets the direction of placing data in the table. When selecting **Down** value, the table is created with data reading direction from top to bottom. When selecting **Up** value, the table is created with data reading direction from bottom to top.

- **Down.** Title row and header row of columns are located in the top part of the table. If you select **Insert rows** and click **Down**, a new row is inserted below the current one.
- **Up.** Title row and header row of columns are located in the bottom part of the table. If you select **Insert rows** and click **Up**, a new row is inserted above the current one.

### Cell styles

Is intended to determine a new cell style or change the current cell style. It is possible to create any number of cell styles.

#### Drop-down list of cell styles

Selects and displays cell styles used in the table.



#### Create a new cell style

Opens the **Create New Table** dialog box to create a new cell style based on that selected in the drop-down list.



#### Manage Cells Styles

Opens the **Manage Cell Styles** dialog box.

### General tab

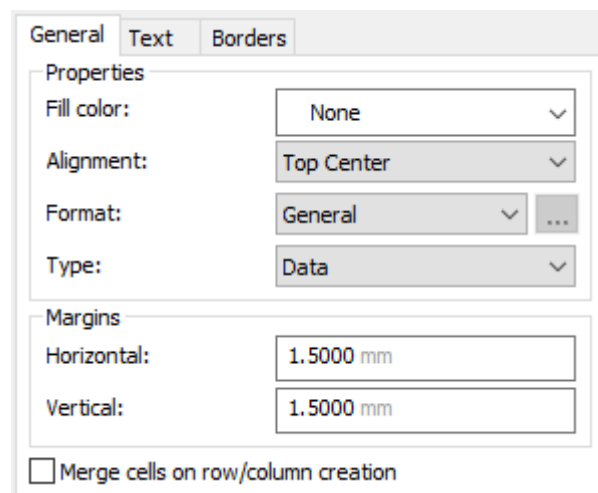

#### Fill color

Specifies background color for cells.

#### Alignment

Specifies the text alignment in the table cells. Relative to upper and lower cells borders the text can be aligned center, top or bottom. The text can be aligned center, left or right relative to left and right cell borders.

#### Format

Determines the data type and formatting for table rows containing data column headers and table title.

#### Type

Determines the cell style: **Label** or **Data**.

#### Horizontal

Specifies the distance between text/block and left and right cell borders.

**Vertical**

Specifies the distance between text/block and upper and lower cell borders.

**Merge cells on row/column creation**

When creating a new row/column using the current cell style, the cells of this row/column are merged in one cell. Using this option you can create a title row in the top of the table.

*Text tab*

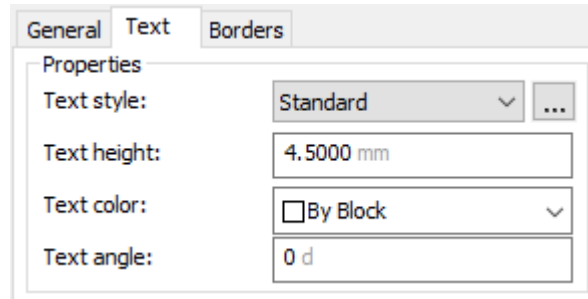

**Text style**

List of available text styles. Button  opens the **Text Style** dialog box, in which you can create or change text styles.

**Text height**

Specifies the text height.

**Text color**

Specifies the text color.

**Text angle**

Specifies the text rotation angle. It is possible to enter any angle from -359 to +359 degrees.

*Borders tab*



**Lineweight**

Assigns lineweight to borders, which are set using the **Border** button. When using wide lines, you may need to increase spaces from cell borders.

**Linetype**

Linetype to be applied to borders set by the user. Select **Load** to load the user linetype.

**Color**

Specifies color to be applied to borders specified by the borders selection button.

**Double line**

Displays table borders in form of double lines.

**Spacing**









Determines the spacing for borders displayed in form of double lines.

**Border buttons**

Applies weight and color of lines to all border or only to certain parts.

# Getting Inquiry

## Measuring Distance and Angles

-  Ribbon: **Home – Utilities – Inquiry** >  **Distance**
-  Menu: **Tools – Inquiry** >  **Distance**
-  Toolbar: **Main** – 
-  Toolbar: **Inquiry** – 
-  Command line: **DI, DIST, MEASUREGEOM**

Use the **Distance** command to measure the distance between specified points.

The angle in the XY plane is measured from the current X-axis, and the angle of the XY plane is measured from the current XY plane.

The measured values of the distances and angles are displayed in the command line in the current units format.

### Command options:

- Multiple points                      Specifying multiple points to measure the total distance.
- Undo                                      – Undoes the specified points one by one.
- Total                                      – Outputs information to the command line.







### Command prompts:

- Specify first point:                      Specify the first point.
- Specify second point:                      Specify the second point.

In the command line the following values are displayed: the distance between specified points; angle between points in the XY plane; angle between the imaginary line drawn through the points and XY plane; and delta of coordinates on the X, Y, and Z axes.

Distance = 270.0000, Angle in XY Plane = 35, Angle from XY Plane = 0  
Delta X = 221.1711, Delta Y = 154.8656, Delta Z = 0.0000

## Point Coordinates

-  Ribbon: **Home – Utilities – Inquiry** >  **Coordinates**
-  Menu: **Tools – Inquiry** >  **Point Coordinates**
-  Toolbar: **Inquiry** > 
-  Command line: **ID**

The **Point Coordinates** command displays the coordinates of the specified point.

### Command prompts:

- Specify point:                      Specify point by the cursor.



The point coordinates in the current UCS will be displayed in the command line:

X = 235 Y = 370 Z = 0

## Cumulative Length

 Ribbon: **Home – Utilities – Inquiry >**  **Cumulative Length**

 Menu: **Tools – Inquiry >**  **Cumulative Length**

 Toolbar: **Inquiry >** 

 Command line: **CLENGTH**

This command calculates common length of selected objects.

1. Call **Common Length** command.
2. Select objects.
3. Press **ENTER**



The calculated value of the cumulative length of objects is displayed on the command line.

In command mode, selecting the following objects and pressing ENTER adds their length to the calculated one.

## Calculating an object's area

 Ribbon: **Home – Utilities – Inquiry >**  **Area**

 Menu: **Tools – Inquiry >**  **Area**

 Toolbar: **Inquiry –** 

 Command line: **AA, AREA**

The **Area** command allows you to calculate area and perimeter by specifying points in the field or selecting an object.

If the field whose area needs to be calculated is not closed, the area value is calculated as if the last and first point were connected by a straight line. When calculating the perimeter, the length of this segment is taken into account in the area definition mode and is not taken into account in the object selection mode.

### Command options:

<u>Length</u>	Specifying the segment length, the construction angle is indicated on the screen.
<u>Undo</u>	Cancels the specified points one by one.
<u>Total</u>	Terminates the command and displays information in the command line.
<u>Object</u>	Enables object selection mode. The command line will display the <b>Selecr objects</b> prompt:
<u>Add area</u>	Enables adding mode (when calculating the total area of several areas or objects).
<u>Subtract area</u>	Enables subtraction mode (when calculating the total area of several areas or objects)

### Command prompts:

Specify first corner point or  
[Object/Add area/Subtract area]  
<Object>:

Specify the first point of the calculated area.

Specify next point or  
[Length/Undo]:

Specify the following points. The calculated area is highlighted in green. Press **ENTER** to complete the command.

The command line displays area and perimeter in the current unit format:

Area = 600, Perimeter = 100

### To calculate the total area of several fields or objects:

1. Run the **AREA** command.
2. Select the **Add area/Subtract area** mode.
3. Sequentially indicate the points of the field whose area needs to be calculated. Press **ENTER**. Repeat for the next field. Or select the **Object** mode and specify the object whose area you want to add/subtract. The command line displays the area and perimeter of the last area or object and the total area:  
Area = 150, Perimeter = 50  
Total area = 225

## Cumulative Area



Ribbon: **Home – Utilities – Inquiry** >  **Cumulative Area**



Menu: **Tools – Inquiry** >  **Cumulative Area**



Toolbar: **Inquiry** > 



Command line: **CAREA**

This command calculates common area of selected objects.

1. Call **Cumulative Area** command.
2. Select objects.
3. Press **ENTER**

The calculated value of the cumulative area of objects is displayed on the command line.

In the command mode, selecting the following objects and pressing ENTER adds their area to the calculated one.

## Displaying Data on Selected Objects Properties



Ribbon: **Home – Utilities – Inquiry** >  **List**



Menu: **Tools – Inquiry** >  **List**



Command line: **LIST**

This command displays properties of selected objects in command line. You can copy displayed data and save it in text file.

1. Run **List** command.
2. Select objects.
3. Press **ENTER**.



Displayed properties:



- space (Model or Layout) of object;
- object type;
- layer;
- linetype scale;
- coordinates X, Y, Z in the current UCS;
- geometry properties of object;
- additional data depend on object type.

## Inquiry

 Ribbon: **Home – Utilities – Inquiry** >  **Inquire**

 Menu: **Tools – Inquiry** >  **Inquiry ...**

 Toolbar: **Main** – 

 Toolbar: **Inquiry** – 

 Command line: **INQUIRY, MEASUREGEOM**

**Inquire** (or **Take from drawing** is another name for this command in some context menus, for example, in the **Chamfer**, **Fillet** dialogs or in the context menus of the dialogs for setting leader parameters) allows you to take properties from a drawing or from standard details. The **Value picker** toolbar appears.

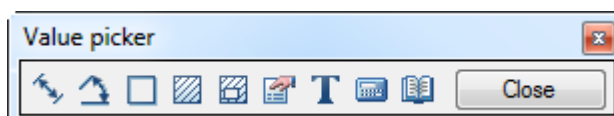

Measured value displayed in the same **Value picker** dialog box:

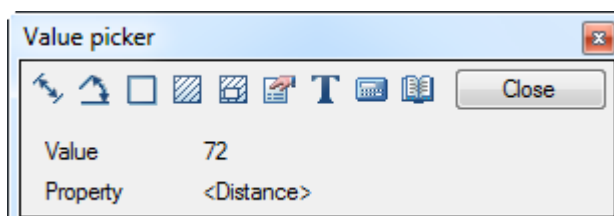

**ATTENTION!** The precision of displaying measurements and calculations for commands of the **Value picker** dialog corresponds to the value set in the **Drawing Units** dialog (menu **Format > Units...**).

**Options:**



**Measure distance:**

Measures the distance between specified points, radius or diameter. You can switch the method of measurement from the context menu or the command line.



**Measure angle:**

Measures the angle. You can switch the method of measurement from the context menu or the command line.



**Measure perimeter:**

Measures the perimeter of the closed area or the length of the closed polyline or circle.

**To measure:**

- Click inside the enclosed area (the measured contour is highlighted).
- Click on the closed polyline or circle.



**Measure area:**



Measures the area of the closed contour.

**To measure:**

- Click inside the enclosed area (the measured area is indicated by hatching).
- Click on the closed polyline or circle.



**Complex area:**



Measures some areas of the closed contours.

**To measure:**

- Click inside each enclosed area (the measured areas are indicated by hatching),
- Click on all the closed polylines or circles.

Press **ENTER** to finish selection of the closed areas (of polylines and circles). The calculated value of the complex area is displayed in the dialog box.





**Take from property:**  
**B**

The command takes the values of any parameter from the selected nanoCAD objects on the drawing (dimension, leader, table, etc.).

The parameters values of the selected object are displayed in the list in the new window:

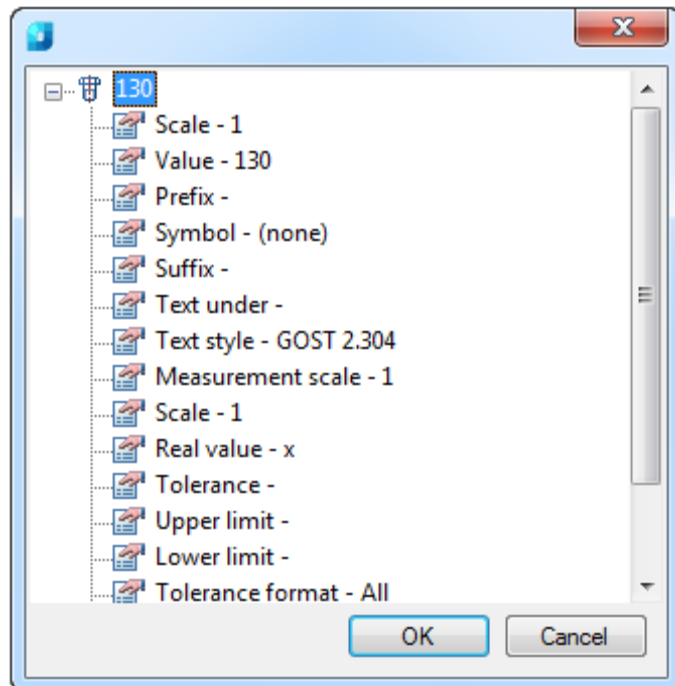

**Take from text:**  
**N**

Takes the values of the selected single line or multiline text:

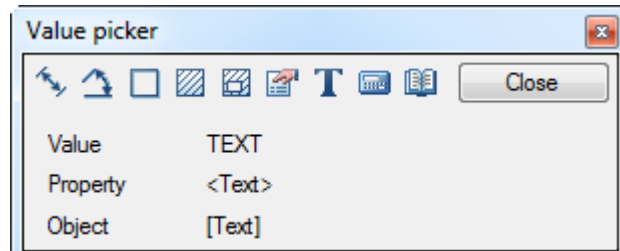

To select text, place the cursor over it. The selection is highlighted by a frame.



**Calculate**

Opens the [Calculator](#).



**Take from notes**

Opens the [Notepad](#).

**NOTE:** If the **Value picker** dialog box was called up at the runtime of another command (for example, from the **Position note** dialog box of the **Pick from drawing** command from the context menu), the measured value is passed to this dialog box.

## Mass Properties of 3D-Solids and Regions



Ribbon: **Home – Utilities – Inquiry** >  **Mass Properties**



Menu: **Tools – Inquire** >  **Mass Properties**



Command line: **MASSPROP**

This command calculates mass properties of 3D-solids and regions: volume, area, moment of inertia, center of gravity, etc. Results may be saved into text file.

1. Run **Mass Properties** command.
2. Select objects. It's possible to select several regions if they are collinear to the first one.
3. Press **ENTER**.

Calculated results are displayed in the command line.

4. Write analysis to a file? [Yes/No]- select **Yes** to save results into text file. Then specify the path and name of file.

**Mass Properties** displays different properties depending on selected objects.

## Set Variable



Ribbon: **Home – Utilities – Inquiry** >  **Variables**



Menu: **Tools – Inquiry** >  **Set Variable**



Command line: **SETVAR**

The command displays a list of system variables and allows modifying their values.

The system variables define the mode of command operations. Use the system variables to turn on/off various modes, for example **SNAP**, **GRID**, **ORTHO**. The system variables set the modes of the objects displaying on the screen and their displaying at the print, for example the **XCLIP** and **IMAGEFRAME** variables manage displaying of the show borders of the external references and raster images. The system variables are used to set the values used by default, for example the **HPSCALE** system variable sets the default scale for the hatch patterns. The system variables are used to store information about program settings as well as information about the drawing to display information about the current status of the program settings and to change them.

### Command prompts:

Enter variable name or ?:

Enter the variable name, for example **IMAGEFRAME**.

IMAGEFRAME <1>:

Enter new value of the variable and press **ENTER**.

**NOTE:** You can change the value of the system variables directly in the command line. To do this, type the variable name and press **ENTER**. Then type new variable name and press **ENTER**.

Command: imageframe

Command: SETVAR

SETVAR – Enter variable name or

Enter variable name or ? : IMAGEFRAME

IMAGEFRAME <0>: 1

### To display a list of the current variables:

1. Type the **?** as an answer to the prompt Enter variable name or ? and press **ENTER**.
2. Press **ESC** to finish the command.
3. A list of the system variables and their values displayed in the command line. For larger display press the **F2**:

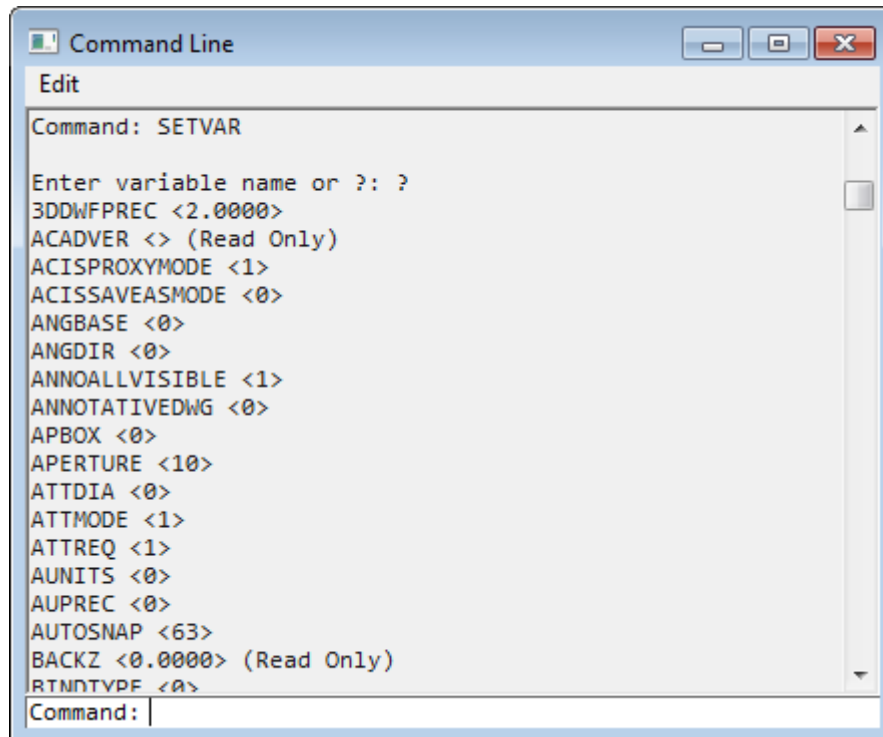

## Calculator





Button:  **Calculator**

The calculate button is available in the [Value picker](#) dialog box, the [Edit Dimension](#) dialog box and the **Table edit** toolbar.

You can perform simple and more complex mathematical calculations in the table cells using the calculator functions.

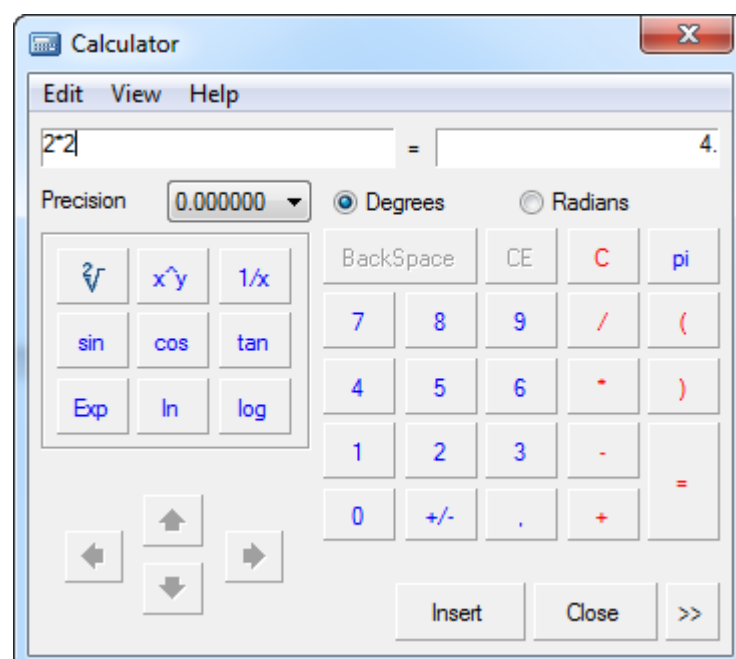
The capabilities of the table editor are significantly expanded using the powerful functionality of the calculator.



It is possible to connect the calculator to the **Notepad**  tool.

To access the **Notepad**, click the button :

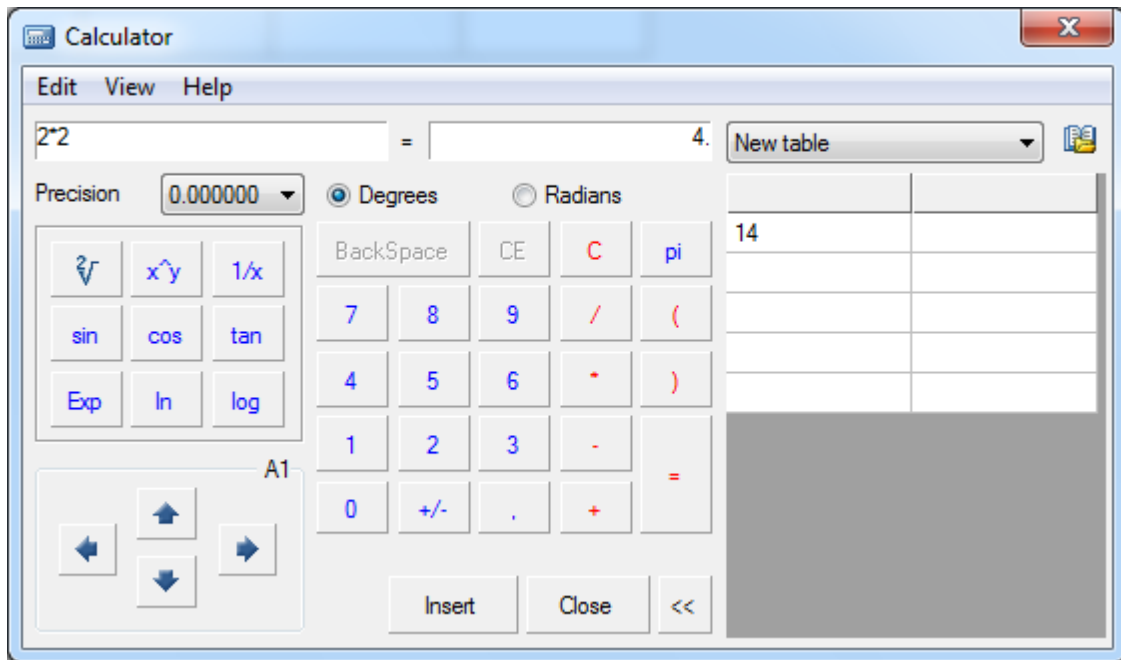

The drop-down list displays the tables from the **Notepad**. This tool is useful when you frequently perform standard calculations.

The **Insert** button is used to insert the result of the calculation from the calculator into the edited table cell or input field.

You can use the arrow buttons from the bottom left corner to select table cells. The name of the current cell is also displayed:



You can use the **Expression** command from the **View** menu to calculate formulas:

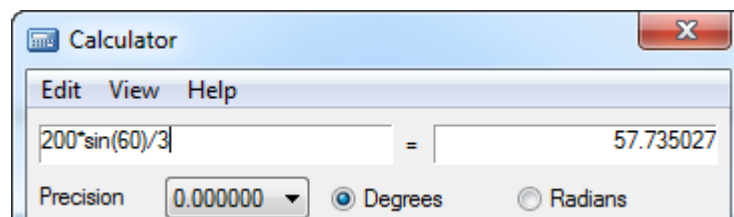

Use the left field to enter the formula to be calculated. The result will be displayed in the right field.

The **Precision** option sets the rounding level of the calculation result.

## Notepad



Button:  **Notepad**

The **Notepad** button is available in the **Value picker** dialog box and in the **Table edit** toolbar.

**Notepad** is used to enter temporarily used text (acronyms, symbols etc.). It is a universal tool for text input.



**Notepad** permits:

- The saving of a set of expressions and their positional structure in a file;
- Entering and placing of text expressions;
- Entering and placing small tables;
- Searching and editing of previously created notes.

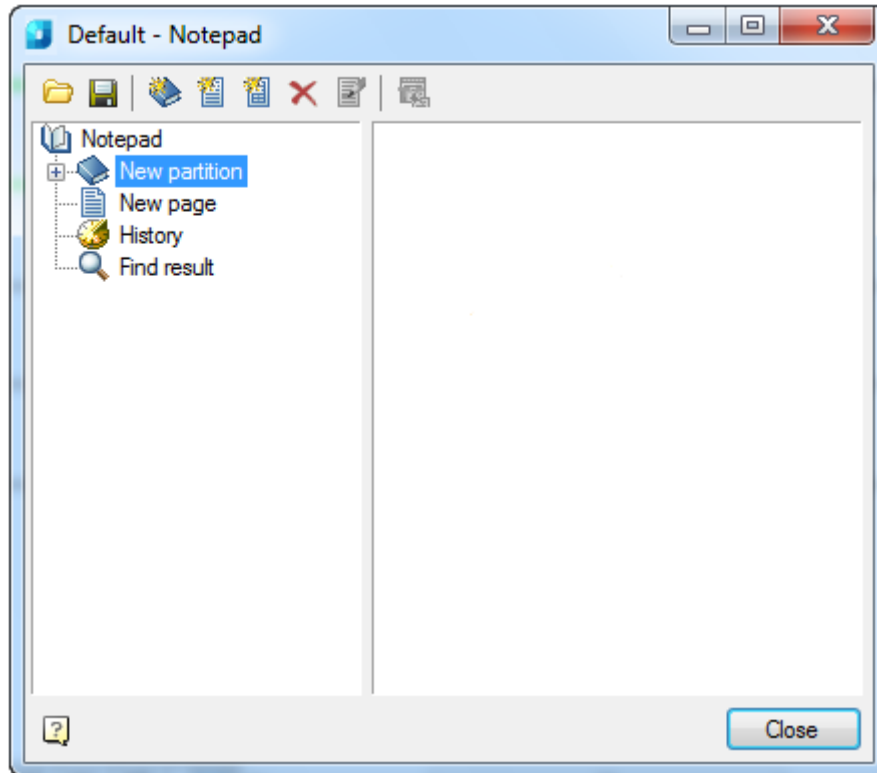



There is a content tree in the left part of **Notepad**. The user can select partitions, pages and tables there. There are control buttons in the top part:



*Buttons:*

- |   |                        |   |
|---|------------------------|---|
|  | <b>Load from file:</b> | Opens the Notepad file saved on the disk. |
|  | <b>Save:</b>           | Saves changes in the Notepad file.        |

*These buttons control the structure of the Notepad:*

- |   |                          |  |
|---|--------------------------|--|
|  | <b>Add partition:</b>    | Adds partitions.   |
|  | <b>Add page:</b>         | Adds page.   |
|  | <b>Add table:</b>        | Adds table.  |
|  | <b>Delete tree item:</b> | Deletes tree item.   |
|  | <b>Edit page:</b>        | Switches on page and table editing mode. This button is available if a page or table is selected in the tree. When editing a page, the tree becomes unavailable and the edit toolbar buttons show in the right part of the dialog box: |

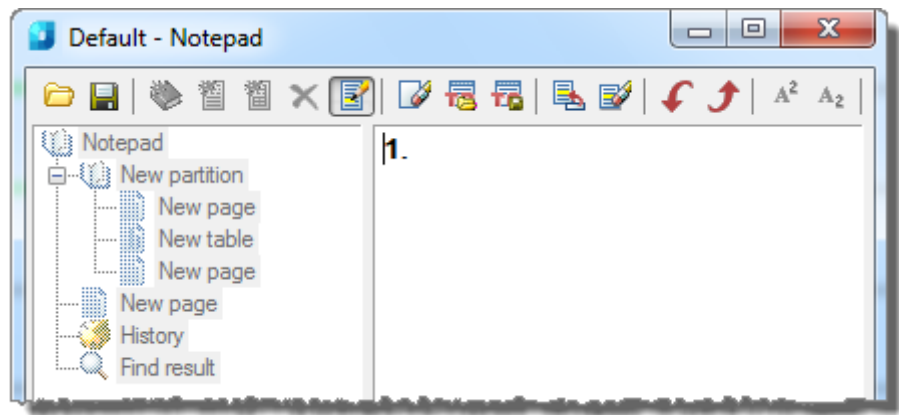

or the table:

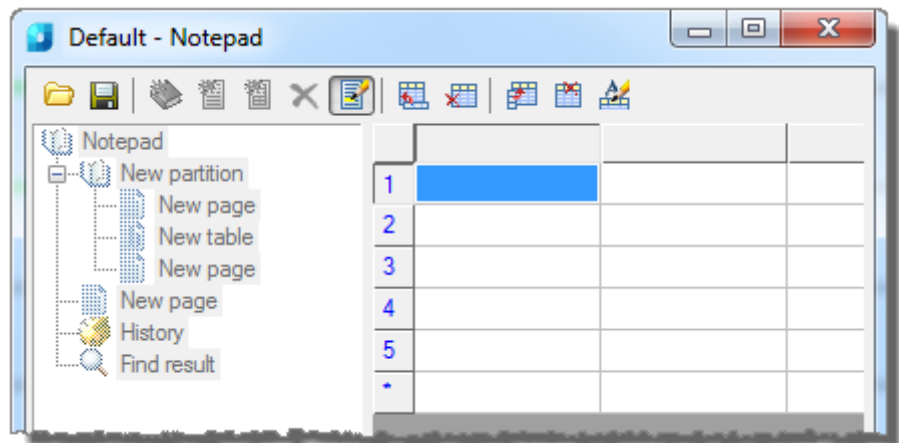

**Select/  
Transfer  
selected  
text:**

Transfers the selected text into the edited table cell.  
If page or table is selected in the tree, its content is displayed in the right part of the dialog box.

**To transfer selected text:**

- Select the text.
- Select the Select/Transfer selected text button.

*Page editing tools:*



**Clear:**

Clears the current page.



**Load from file:**

Allows importing of text from an MS Word RTF-file.



**Save to file:**

Allows writing of the page content into an RTF-file for using in MS Word.



**Add technical  
condition:**

Adds technical condition.



**Delete technical  
condition:**

Deletes technical condition.



**Move down:**

Moves the row down.



**Move up:**

Moves the up down.



**Superscript:**

Turn on/off the input mode for upper index.



**Subscript:**

Turn on/off the input mode for bottom index.

 **Insert special symbol:** Opens the panel to select and insert special symbols.

 **Insert fraction:** Opens the **Insert fraction** dialog box to set the numerator and denominator of the fraction:

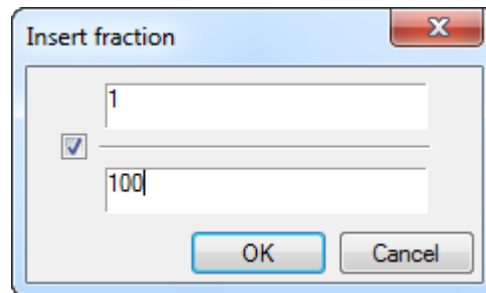

The switch  controls the display of the fraction line.

 **Insert tolerance:** Opens the **Fit** dialog box.

 **Insert material:** Opens the **Material** dialog box.

 **Calculator:** Opens the **Calculator** dialog box.

*Table editing tools:*

 **Insert row** Inserts row.

 **Delete row** Deletes row.

 **Insert column** Inserts column.

 **Delete column** Deletes column.

 **Rename column** Opens the **Column properties** dialog box, in which you can set the width and name of the selected column:

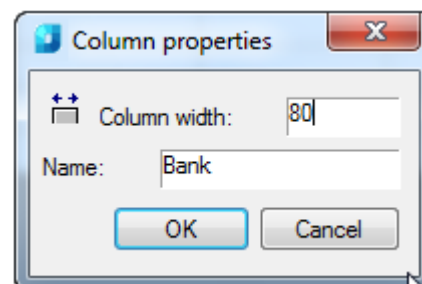

**NOTE:** When you use the **Notepad** for the first time, it is recommended to save the new notepad in a separate file using the **Save** button.

The dialog box has a special search tool to search the text line. Right click on any partition or page of the partition and select the **Find** command from the context menu. The found links are placed in the **Find result** section.

To speed up the search procedure, you can view recently used expressions in the **History** section:

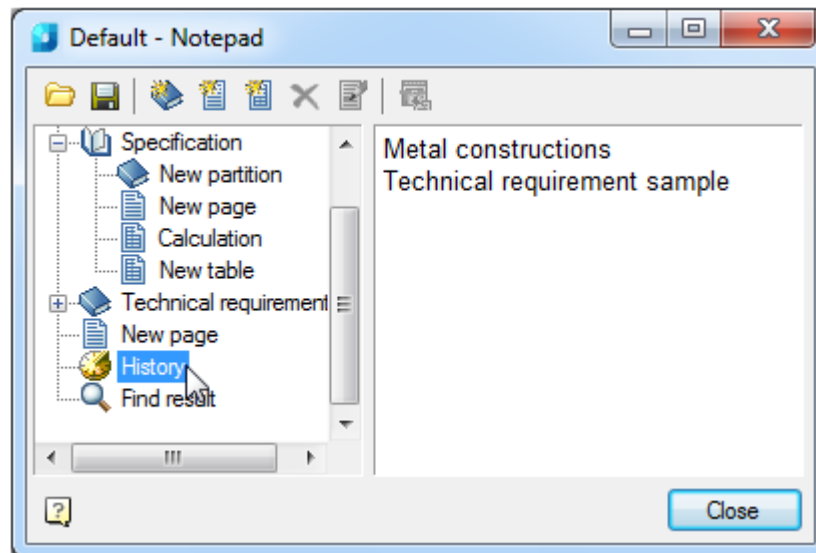

You can create an unlimited number of sections and subsections, pages and tables in the **Notepad**:

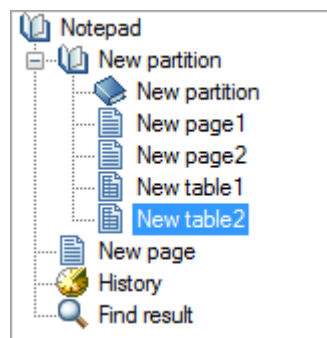

You can move the partitions, pages and tables in the structural tree by using drag and drop. To rename the partitions, pages and tables, use the **Rename** command from the context menu. When you want to close the dialog box, it offers to save the changes in the **Notepad**:

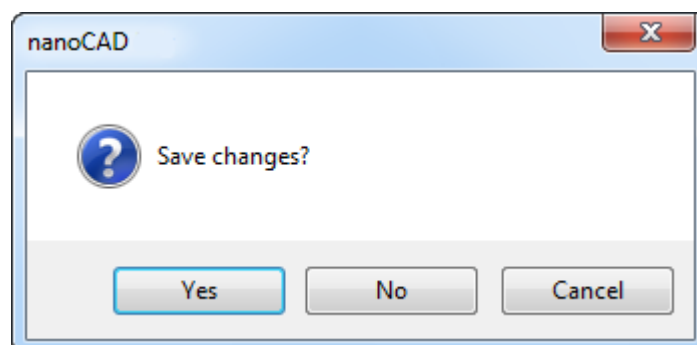

## Features of the Design Elements

### Commands for Editing nanoCAD's Objects

#### The "Edit" Command



Icon:  **Edit**





Command line: **EDIT**

The command allows you to edit nanoCAD's objects such as tables, notes, dimensions, singleline and multiline text.

The command opens following dialogs for editing:

- a table, a note, a dimension, a singleline and a multiline text (the **Text settings** dialog window) - if **Yes** is chosen for **Program objects**, **Dimensions**, **Regular text** and **Multi-texts** options of the **Settings nanoCAD Int** dialog box on the **Main options** tab of the **By double-click** section (the **Tools** menu –**Advanced Settings**),
- a table, a note, a dimension – if **No** is chosen for the **Program objects** and **Dimensions** options of the **Settings nanoCAD Int** dialog box on the **Main options** tab of the **By double-click** section.

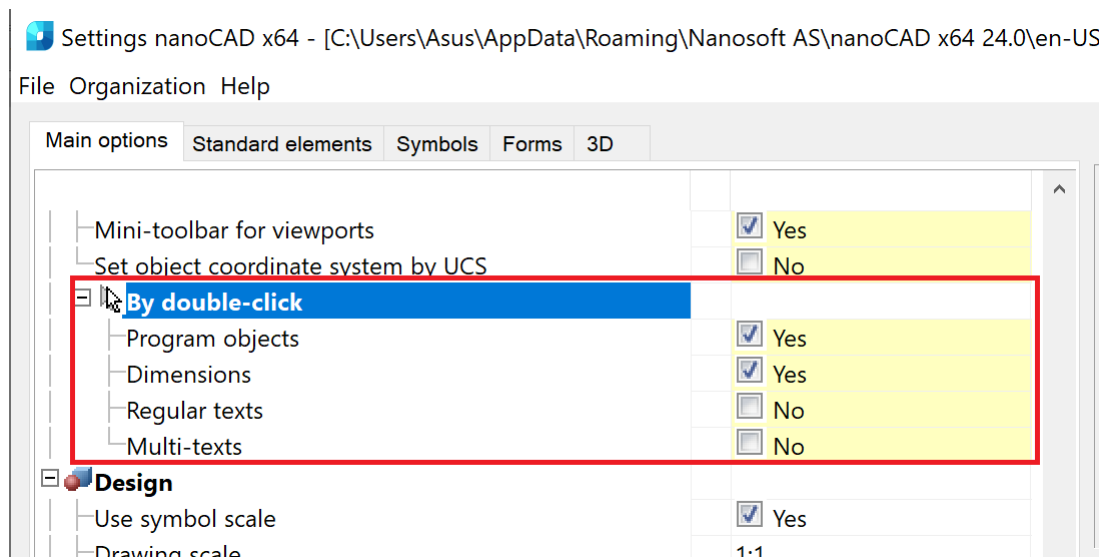

For more information, see the corresponding sections of this guide.

## The "Fedit" Command



Icon:  **Edit**



Command line: **FEDIT**

The command allows you to edit nanoCAD's objects such as tables, notes, dimensions, singleline and multiline text.

The command opens following dialogs for editing:

- a table, a note, a dimension, a singleline and a multiline text (the **Text settings** dialog window) - if **Yes** is chosen for the **Program objects**, **Dimensions**, **Regular text** and **Multi-texts** options of the **Settings nanoCAD Int** dialog box on the **Main options** tab of the **By double-click** section (the **Tools** menu –**Advanced Settings**),
- a table, a note, a dimension – if **No** is chosen for the **Program objects** and **Dimensions** options of the **Settings nanoCAD Int** dialog box on the **Main options** tab of the **By double-click** section.

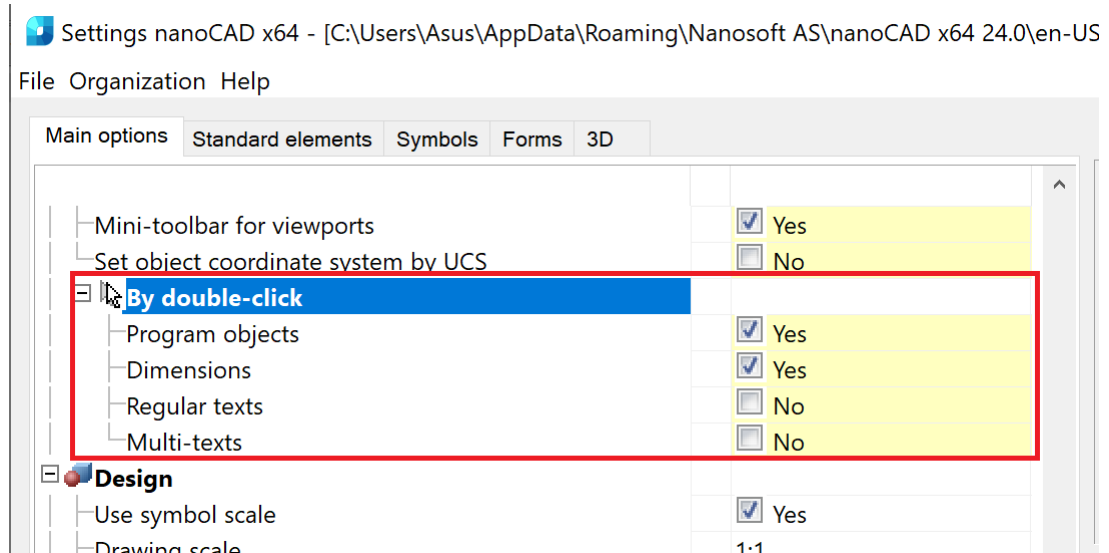

For more information, see the corresponding sections of this guide.

## The "In Place Edit" Command



Icon:  **In place edit**



Command line: **IPEDIT**

This command allows you to edit all nanoCAD's objects, containing text, directly in the drawing. To quick-start the command, press and hold down the **CTRL** key and left click on the object. After running the command, the cursor appears in the text line of the edited object:

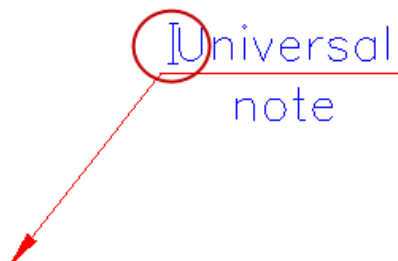

## Parameters Redefinition



Button:  **Parameters redefinition**



Command line: **PR**

This command is used to define the variations in the settings of the nanoCAD design objects in the current drawing. The redefinition is controlled by the parameters set in the settings of the design elements (the **Tools** menu – the **Advanced Settings** command).

The command allows you to check the redefinition status of one, several or all objects in the drawing.

The **Parameters redefinition** command opens the **nanoCAD Int - Redefine object parameters** dialog box:

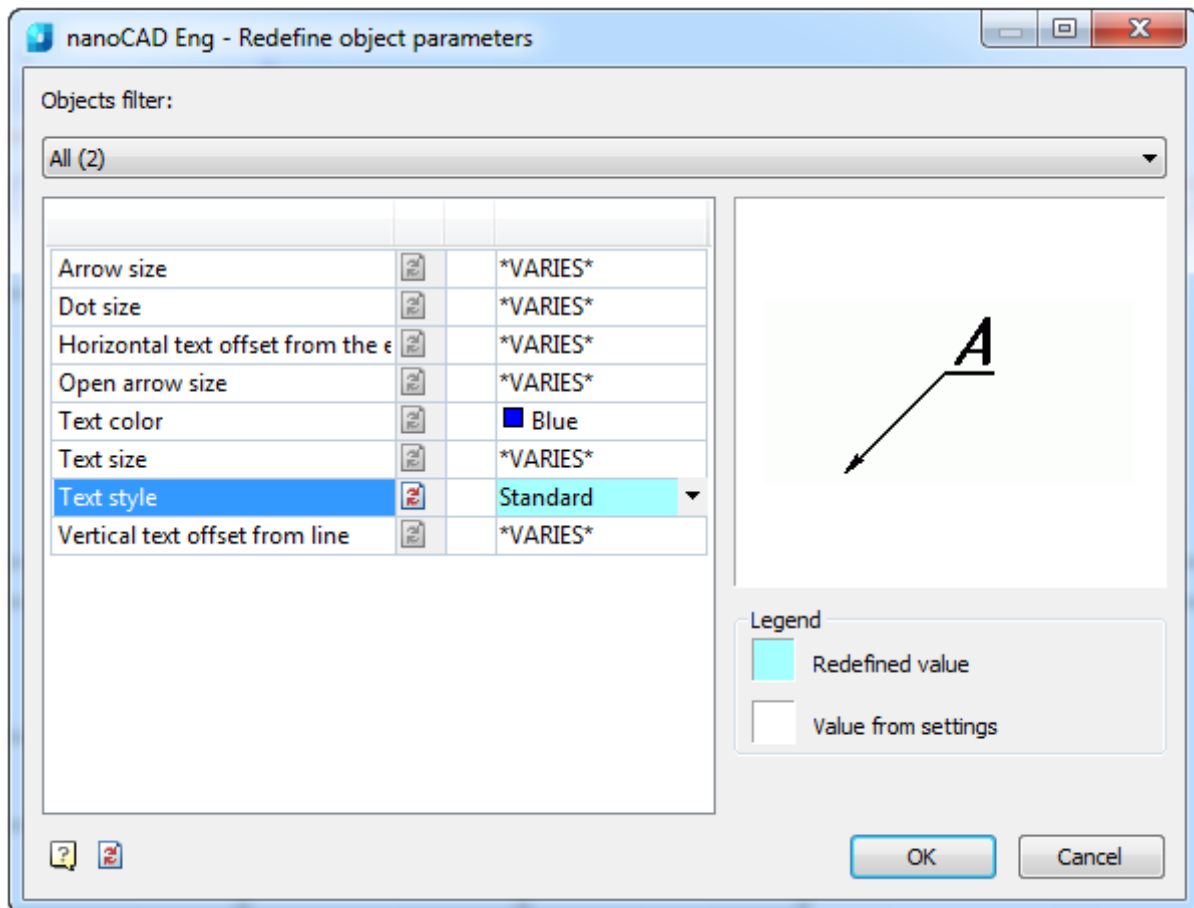

The objects are grouped by type in the dialog box. The objects' parameters are grouped by name.

To set parameters or remove redefinitions, use the **Object filter** list:

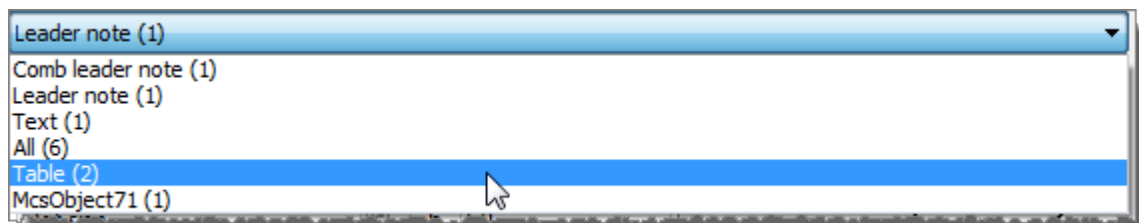

The total number of found objects in the drawing iare displayed in the brackets for each object type.

When an object type is selected, its properties will be displayed in the parameters table and its graphical view will be displayed in the right box of the dialog box:

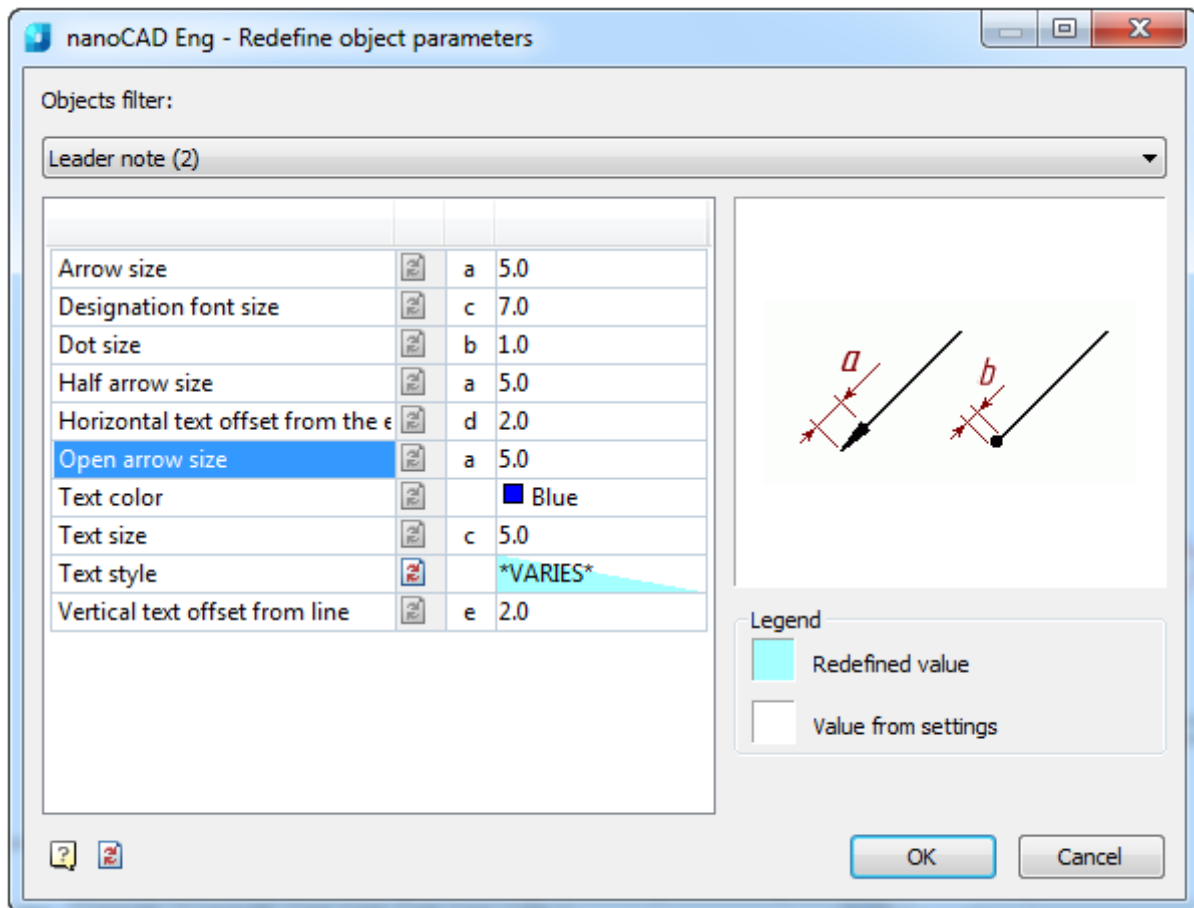

The redefined parameters are highlighted in blue. If, for the selected objects group, only some parameters have redefinitions, then the redefinition highlighting will be diagonal:

Text size	c	7.0
Text style		*VARIES*

To remove the redefinition, it is necessary to click the icon .

To remove the redefinition from all objects, it is necessary to click the **Clear redefinition from all parameters** icon in the left bottom part of the dialog box:

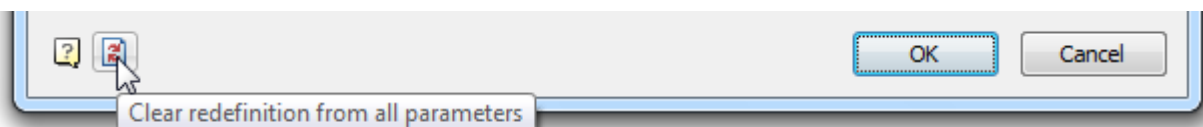

It is possible to enter the new value for the selected parameter from the keyboard or select from the drop-down list:

Arrow size	a	5.0
Designation font size	c	7.0
Dot size	b	1.8
Half arrow size	a	3.5
Horizontal text offset from the line	d	5
Open arrow size	a	7
Text color		10
Text size	c	14
Text style		20
Text style		*VARIES*
Vertical text offset from line	e	2.0

If the new value aligns with a value specified by default in the **Settings nanoCAD Int** dialog box (the **Tools** menu – the **Advanced Settings** command), the blue highlighting will not be displayed.

*To change the parameters of one or several design elements, it is necessary to:*

1. Select the objects on the drawing.
2. Select the **Parameters redefinition** command from the context menu.
3. In the opened dialog box set new values for the settings. The changes apply only to the selected objects.

The **Parameters redefinition**  command is useful to check documents for compliance of design elements with corporate company standards.

*To check the redefinition status of all objects on the drawing:*

1. Start the **Parameters redefinition** command.
2. Press **ENTER** to select all nanoCAD design elements. They will be highlighted on the drawing.
3. Click the **Clear redefinition** from all parameters  icon to clear redefinition from all parameters. As a result, you obtain a document designed according to the settings set by your company (consisting in part of nanoCAD elements).

## Regenerate



Button:  **Regenerate**



Command line: **REGENOBJ**

This command is used to:

- Regenerate the nanoCAD objects,
- Regenerate overlapping of the nanoCAD objects,
- Regenerate the tables,
- Update automatically calculated attribute values.

# 3D MODELING AND VISUALISATION

## Surfaces

nanoCAD allows you to create a polygon or polyface mesh by specifying vertices. The mesh density controls the number of facets in legacy polygonal and polyface meshes. Density is defined in terms of a matrix of  $M$  and  $N$  vertices, like a grid consisting of columns and rows.  $M$  and  $N$  specify the column and row position, respectively, of any given vertex.

The mesh density (i.e., the number of its edges) is set by the product  $(M-1) \times (N-1)$ , where  $M$  is the number of vertices along the first direction, and  $N$  is the number of vertices along the second direction (directions are called the *M-direction* and *N-direction*). The position of any vertex in the network is determined by two indices, similar to the row and column numbers in the matrix. When modeling with the help of three-dimensional networks, not only the edges of a three-dimensional object are described, but also its faces. Using meshes, you can get an approximation of curved surfaces with a given accuracy.

Mesh objects do not have the mass and volume properties of 3D solids.

In the ribbon tab **3D Tools – Meshes**, as well as in the **Draw** menu – **Meshes** item of the classic interface, the commands for the 3D meshes creation in the form of elementary surfaces are presented – box, wedge, cone, sphere, torus, pyramid, dish, dome, as well as in the form of uniform and non-uniform meshes indicating the number of nodes.

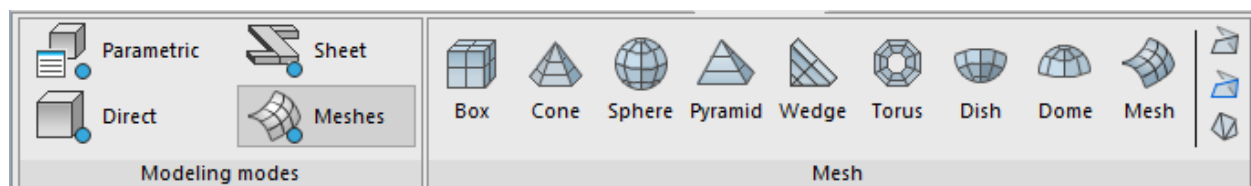

**NOTE:** These objects are of **Sub Mesh, Polyface Mesh** or **Polygonal Mesh** type

You can control whether the mesh is displayed as a wireframe, hidden, or conceptual image by changing the visual style.

### Box

 Ribbon: **Modeling modes – Meshes – Mesh >**  **Box**

 Menu: **Draw – Meshes >**  **Box**

 Command line: **3D – Box**

The command creates a 3D box.

#### Options:

- Cube                      Switch to create a cubic box with edges of equal length.
- Reference                Specify the rotation angle of the box, measured from the reference angle.
- Points                     Specify the rotation angle, measured from the reference angle to the segment, defined by two points.

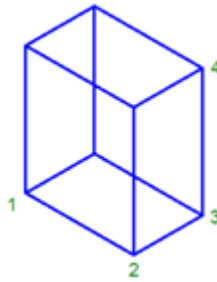

### Command prompts:

Specify corner point of box:	Specify point 1.
Specify length of box:	Specify point 2.
Specify width of box or [Cube]:	Specify point 3 or select the Cube option.
Specify height of box:	Specify point 4.
Specify rotation angle of box about the Z axis or [ <u>Reference</u> ]:	Specify the rotation angle or select the Reference option.
	The rotation angle is set relative to the first corner specified (point <b>1</b> ) and is measured from the X-axis on the XY plane.

When you select the Reference option, the following prompts are displayed:

Specify angle or <0>:	Specify a point or enter the angle value.
Specify new angle or [ <u>Points</u> ]:	Specify a point or enter the angle value or select the <u>Points</u> option.

**NOTE:** The Reference and Points options are useful to define the box orientation relative to an existing object.

## Wedge

 Ribbon: **Modeling modes – Meshes – Mesh >**  **Wedge**

 Menu: **Draw – Meshes >**  **Wedge**

 Command line: **3D – Wedge**

The command creates a right-angled wedge-shaped polygon.

### Command options:

<u>Reference</u>	Specifies the rotation angle of the wedge, counted from the reference angle.
<u>Points</u>	Specifies the rotation angle, counted from the reference angle to the conditional segment, specified by two points.

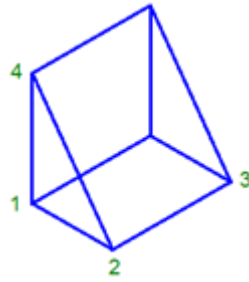

**Command prompts:**

Specify corner point of wedge:	Specify point 1.
Specify length of wedge:	Specify point 2.
Specify width of wedge:	Specify point 3.
Specify height of wedge:	Specify point 4.
Specify rotation angle of wedge about the Z axis or [ <u>Reference</u> ]:	Specify a point or enter an angle value. The rotation angle is set relative to the first corner specified (point <b>1</b> ) and is measured from the X-axis on the XY plane.

**Command prompts when selecting the Reference option:**

Specify the reference angle <0>:	Specify the point or enter the angle value.
Specify the new angle or [ <u>Points</u> ]:	Specify the point or enter the angle value, or select the <u>Points</u> option,

**NOTE:** It is convenient to use the Reference and Points options to specify the wedge orientation relative to another existing object.

## Cone



Ribbon: **Modeling modes – Meshes – Mesh >**  **Cone**



Menu: **Draw – Meshes >**  **Cone**



Command line: **3D – Cone**

The command creates a cone-shaped polygon mesh.

**Option:**

Diameter      Switch to specify the diameter.

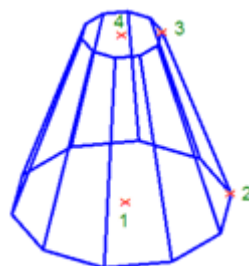

**Command prompts:**

Specify center point for base of	Specify the center point for the base of
----------------------------------	--



cone:

Specify radius for base of cone or [Diameter]:

Specify radius for top of cone or [Diameter]<0>:

Specify height of cone:

Enter number of segments for surface of cone <16>:

the cone (point 1).

Specify the radius for the base of the cone (point 2) or select the Diameter option.

Specify the radius for the top of the cone (point 3) or select the Diameter option. A value of 0 (set by default) produces a cone. A value greater than 0 produces a truncated cone.

Specify the height of the cone (point 4).

Enter the number of segments.

## Sphere



Ribbon: **Modeling modes – Meshes – Mesh >**  **Sphere**



Menu: **Draw – Meshes >**  **Sphere**



Command line: **3D – Sphere**

The command creates a spherical polygon mesh.

### Options:

Diameter Switch to specify the diameter.

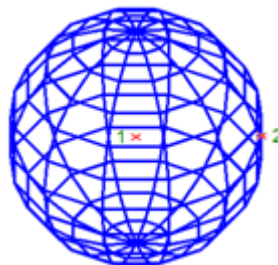

### Command prompts:

Specify center point of sphere:

Specify radius of sphere or [Diameter]:

Enter number of longitudinal segments for surface of sphere <16>:

Enter number of latitudinal segments for surface of sphere <16>:

Specify the center point of the sphere (point 1).

Specify the radius of the sphere (point 2) or select the Diameter option.

Enter the number of longitudinal segments for the surface of the sphere.

Enter the number of latitudinal segments for the surface of the sphere.

## Torus

 Ribbon: **Modeling modes – Meshes – Mesh >**  **Torus**

 Menu: **Draw – Meshes >**  **Torus**

 Command line: **3D – Torus**

The command creates a toroidal polygon mesh.

### Option:

Diameter Switch to specify the diameter.

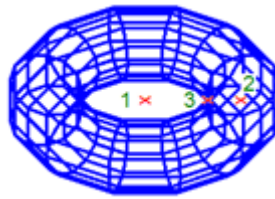

### Command prompts:

Specify center point of torus:

Specify radius of torus or  
[Diameter]:

Specify radius of tube or  
[Diameter]:

Enter number of segments around  
torus circumference <16>:

Enter number of segments around  
tube circumference <16>:

Specify the center point of the torus (point 1).

Specify the radius of the torus (point 2) or  
select the Diameter option.

Specify the radius of the tube (point 3) or  
select the Diameter option.

Enter the number of segments around the  
torus circumference.

Enter the number of segments around the  
tube circumference.

## Pyramid

 Ribbon: **Modeling modes – Meshes – Mesh >**  **Pyramid**

 Menu: **Draw – Meshes >**  **Pyramid**

 Command line: **3D – Pyramid**

The command creates a pyramid or a tetrahedron.

### Options:

Tetrahedron Switch to create the tetrahedron.

Ridge Switch to create a pyramid with a top with a ridge form.

Top Switch to create a truncated pyramid.

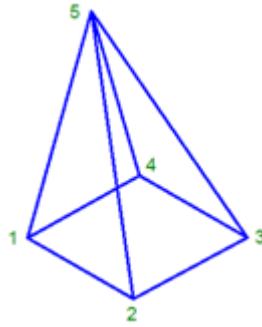

**When you create a pyramid, the following prompts are displayed:**

- |  |                          |
|--|--------------------------|
| Specify first corner point for base of pyramid:                            | Specify point <b>1</b> . |
| Specify second corner point for base of pyramid:                           | Specify point <b>2</b> . |
| Specify third corner point for base of pyramid:                            | Specify point <b>3</b> . |
| Specify fourth corner point for base of pyramid or [ <u>Tetrahedron</u> ]: | Specify point <b>4</b> . |
| Specify apex point of pyramid or [ <u>Ridge/Top</u> ]:                     | Specify point <b>5</b> . |

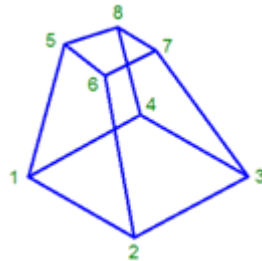

**When you create a truncated pyramid, the following prompts are displayed:**

- |  |                               |
|--|-------------------------------|
| Specify first corner point for base of pyramid:                            | Specify point <b>1</b> .      |
| Specify second corner point for base of pyramid:                           | Specify point <b>2</b> .      |
| Specify third corner point for base of pyramid:                            | Specify point <b>3</b> .      |
| Specify fourth corner point for base of pyramid or [ <u>Tetrahedron</u> ]: | Specify point <b>4</b> .      |
| Specify apex point of pyramid or [ <u>Ridge/Top</u> ]:                     | Select the <u>Top</u> option. |
| Specify first corner point for top of pyramid:                             | Specify point <b>5</b> .      |
| Specify second corner point for top of pyramid:                            | Specify point <b>6</b> .      |
| Specify third corner point for top of pyramid:                             | Specify point <b>7</b> .      |
| Specify fourth corner point for top of pyramid:                            | Specify point <b>8</b> .      |

**NOTE:** To create the top of a pyramid, it is necessary to set the points in the same order as for the base.

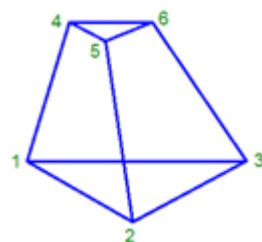

**When you create a truncated tetrahedron, the following prompts are displayed:**

- |   |                          |
|---|--------------------------|
| Specify first corner point for base of pyramid: | Specify point <b>1</b> . |
|---|--------------------------|

Specify second corner point for base of pyramid:

Specify third corner point for base of pyramid:

Specify fourth corner point for base of pyramid or [Tetrahedron]:

Specify apex point of tetrahedron or [Top]:

Specify first corner point for top of tetrahedron:

Specify second corner point for top of tetrahedron:

Specify third corner point for top of tetrahedron:

Specify point **2**.

Specify point **3**.

Select the Tetrahedron option.

Select the Top option.

Specify point **4**.

Specify point **5**.

Specify point **6**.

**NOTE:** To create the top of a tetrahedron it is necessary to set the points in the same order as for the base.

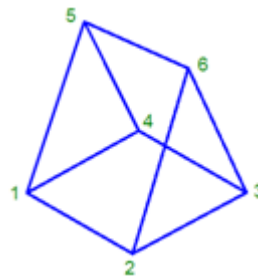

**When you create a pyramid with the top with the ridge form, the following prompts are displayed:**

Specify first corner point for base of pyramid:

Specify second corner point for base of pyramid:

Specify third corner point for base of pyramid:

Specify fourth corner point for base of pyramid or [Tetrahedron]:

Specify apex point of pyramid or [Ridge/Top]:

Specify first ridge end point of pyramid:

Specify second ridge end point of pyramid:

Specify point **1**.

Specify point **2**.

Specify point **3**.

Specify point **4**.

Select the Ridge option.

Specify point **5**.

Specify point **6**.

## Dish

 Ribbon: **Modeling modes – Meshes – Mesh >**  **Dish**

 Menu: **Draw – Meshes >**  **Dish**

 Command line: **3D – Dish**

The command creates the lower half of a spherical polygon mesh.

### Option:

Diameter      Switch to specify the diameter.

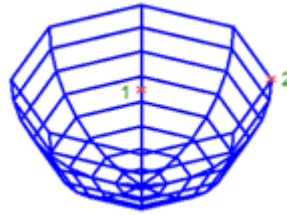

**Command prompts:**

Specify center point of dish:

Specify the center point of the dish (point 1).

Specify radius of dish or [Diameter]:

Specify the radius of the dish (point 2) or select the Diameter option.

Enter number of longitudinal segments for surface of dish <16>:

Enter the number of longitudinal segments for the surface of the dish.

Enter number of latitudinal segments for surface of dish <8>:

Enter the number of latitudinal segments for the surface of the dish.

## Dome



Ribbon: **Modeling modes – Meshes – Mesh >**  **Dome**



Menu: **Draw – Meshes >**  **Dome**



Command line: **3D – Dome**

The command creates the upper half of a spherical polygon mesh.

**Option:**

Diameter      Switch to specify the diameter.

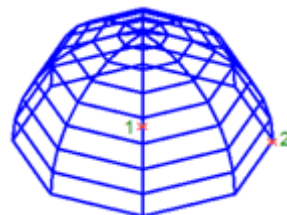

**Command prompts:**

Specify center point of dome:

Specify the center point of the dome (point 1).

Specify radius of dome or [Diameter]:

Specify the radius of the dome (point 2) or select the Diameter option.

Enter number of longitudinal segments for surface of dome <16>:

Enter the number of longitudinal segments for the surface of the dome.

Enter number of latitudinal segments for surface of dome <8>:

Enter the number of latitudinal segments for the surface of the dome.

## Mesh

 Ribbon: **Modeling modes – Meshes – Mesh >**  **Mesh**

 Menu: **Draw – Meshes >**  **Mesh**

 Command line: **3D – Mesh**

The command creates a planar mesh.

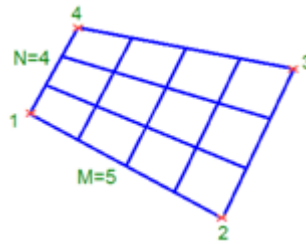

### Command prompts:

Specify first corner point of mesh:	Specify point <b>1</b> .
Specify second corner point of mesh:	Specify point <b>2</b> .
Specify third corner point of mesh:	Specify point <b>3</b> .
Specify fourth corner point of mesh:	Specify point <b>4</b> .
Enter mesh size in the M direction:	Enter a value between 2 and 256.
Enter mesh size in the n direction:	Enter a value between 2 and 256.

**NOTE:** The *M* and *N* directions are similar to the *X* and *Y* axes of an *XY* plane.

**NOTE:** *M* and *N* sizes determine the number of lines drawn in each direction along the mesh.

## 3D Mesh

 Ribbon: **Modeling modes – Meshes – Mesh >**  **3D mesh**

 Menu: **Draw – Meshes >**  **3D Mesh**

 Command line: **3DMESH**

This command creates polygon meshes.

As you create the mesh, you specify the size of the mesh in the *M* and *N* directions.

A pair of *m* and *n* (row number and column number) defines the position of each vertex of the mesh. Specifying of the vertices starts with the vertex (0, 0). The value of *n* changes first.

The vertices can be located at any distance from each other.

You can close the meshes with **PEDIT**.

The following example shows the points corresponding to the vertices for a 3D Mesh with  $N=4$  and  $M=5$  sizes.

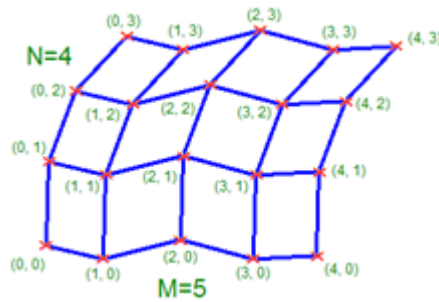



**Command prompts:**

- |                                     |   |
|-------------------------------------|---|
| Enter size of mesh in M direction:  | Enter a value between 2 and 256.            |
| Enter size of mesh in N direction:  | Enter a value between 2 and 256.            |
| Specify location for vertex (0, 0): | Specify the location for the first vertex.  |
| Specify location for vertex (0, 1): | Specify the location for the second vertex. |
| ...                                 | ...   |
| Specify location for vertex (m, n): | Specify the location for the last vertex.   |

**NOTE:** The  $M$  and  $N$  directions are similar to the  $X$  and  $Y$  axes of an  $XY$  plane.

**NOTE:**  $M$  and  $N$  sizes determine the number of lines drawn in each direction along the mesh.

### 3D Face

-  Ribbon: **Modeling modes – Meshes – Mesh >**  **3D Face**
-  Menu: **Draw – Meshes >**  **3D Face**
-  Command line: **3DFACE**

This command creates three- or four-side surface in 3D space. You can draw a few faces in one session of command, each face can be oriented arbitrarily.

Construction begins with the First point request, in response to which you should specify the starting point of the 3D face. Next, by entering two or three more corner points, the location of the edges that bound the created face is specified.

**NOTE** If, as a result of construction, the face acquired an unplanned effect of twisting or self-intersection, then you should check the correct order of specifying the points.

**Option:**

- Invisible Control the visibility of each face. To make the face invisible, select the option Invisible before specifying the first point.

### Command prompts:

Specify first point or  
[Invisible/]

Specify second point or  
[Invisible/]

Specify third point or  
[Invisible/] <exit>

Specify fourth point or  
[Invisible] <create three-  
sides face>

Specify the location of the first point.

Specify the location of the second point.

Specify the location of the third point.

Specify the location of the fourth point or press **ENTER** to create the create three-sides face.

Specify third point and Specify fourth point requests will be displayed until the **ENTER** button will be pressed. You can continue to create adjacent faces by specifying two points. Created by the last pair of points edge will be the first edge for new 3D face.

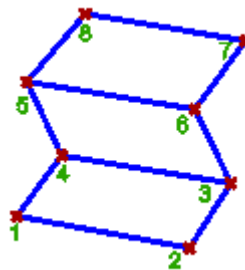

**NOTE:** You can control the visibility of edge of created 3D Face in **Geometry** in **Properties** toolbar.

## 3D Module

### Options 3D Tab

The tab is used to configure 3D settings 3D. The tab is available with a license for 3D.

- [Common settings](#)
- [2D views](#)
- [Pseudo section properties](#)



## Common settings

Common settings	
Automatically project edges on sketch	<input checked="" type="checkbox"/> Yes
Automatically project the origin point on new sket	<input checked="" type="checkbox"/> Yes
Automatically correct UCS while editing block refe	<input checked="" type="checkbox"/> Yes
Restore viewport's camera while exiting 2D sketch	<input checked="" type="checkbox"/> Yes
Edit parametric constraint value upon creation	<input checked="" type="checkbox"/> Yes
Associativity for new bodies	<input type="checkbox"/> No
Layer for sketches	SKETCHES
Layer for working objects	WORKING_ELEMENTS
Layer for sections	SECTIONS
Layer for parametric 3D solids	PARAMETRIC_3DSOLIDS
Show/no thread helix	<input checked="" type="checkbox"/> Yes
Thread helix color	■ Colour 251
Thread face color	■ Colour 250

### Automatically project edges on sketch

The parameter when adding a new sketch adjusts the display of the projection of the edges of a flat face taken as the working plane for the sketch.

Call command **"Add planar sketch"**.

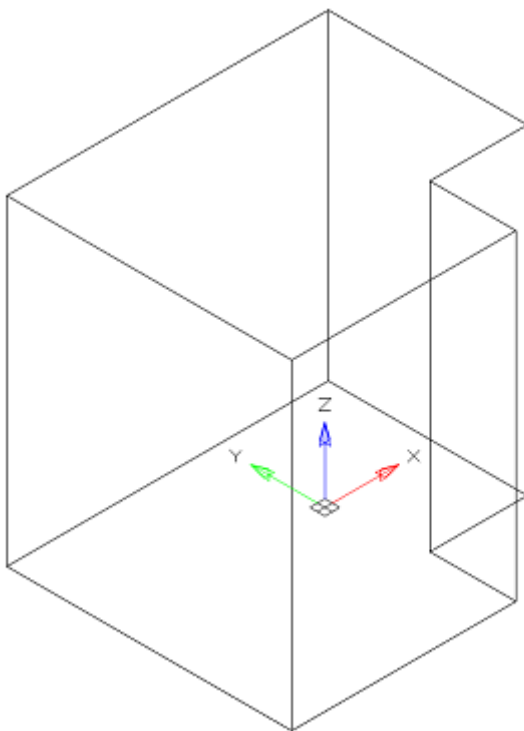

Specify a flat face as a work plane.

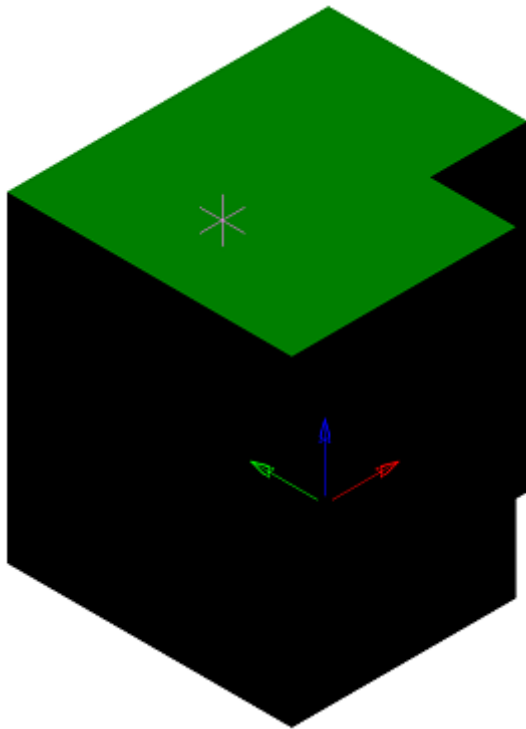

Depending on the setting, a projection will be added to the sketch.

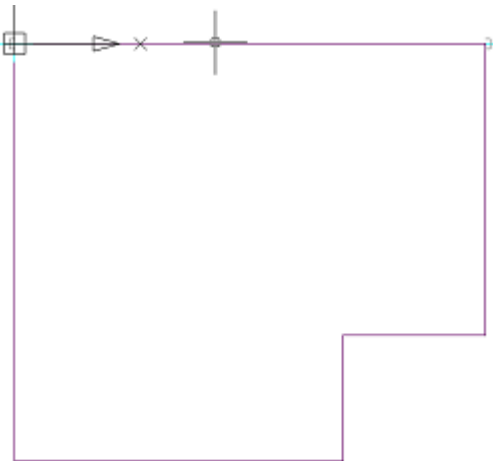
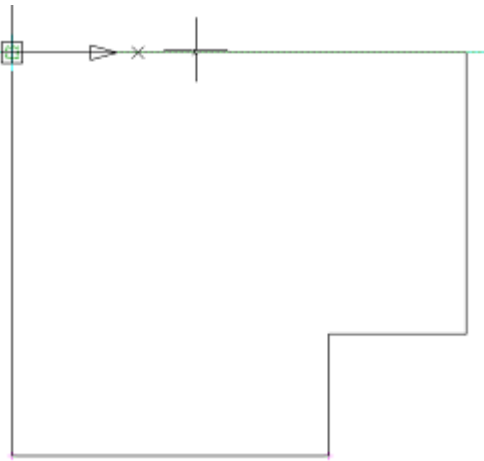
Yes	No
	

**Automatically project the origin point on new sketch**

Controls the projection of the origin point when creating a new sketch.

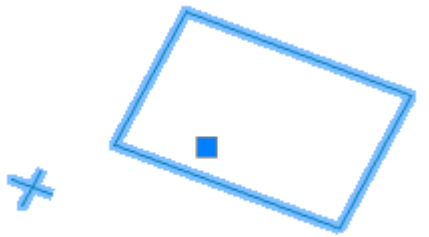
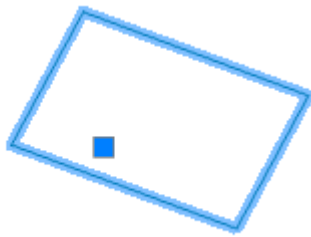
Yes	No
	

**Automatically correct UCS while editing block references with 2D constraints**

Automatic correction of UCS when editing a block reference with 2D constraints.

### **Restory viewport's camera while exiting 2D sketch editing mode**

If enabled, the view camera will be in position before the sketch is edited.

### **Edit parametric constraint value upon creation**

Controls whether the dependency editing dialog is opened immediately after installation.

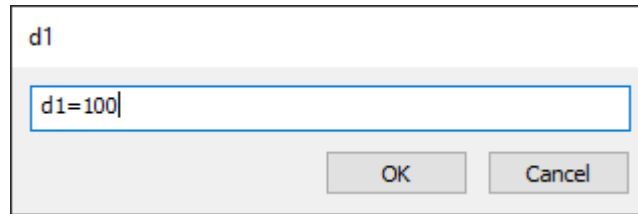

### **Associativity for new bodies**

The enabled option allows you to build fixed bodies without the possibility of defixation. The sketch must be attached to some plane.

### **Layer for sketches**

It allows you to customize the name of the layer on which will be placed flat sketches.

### **Layer for working objects**

It allows you to customize the name of the layer on which the objects will be located.

### **Layer for sections**

It allows you to customize the name of the layer on which section will be located.

### **Layer for parametric 3D solids**

Allows you to set the name of the layer on which the parametric 3D bodies will be located.

### **Show/no thread helix**

Controls the display of the thread helix.

### **Thread helix color**

Thread helix color.

### **Thread face color**

Thread face color.

### **Mass display accuracy**

Mass display accuracy for inspector properties and part and assembly unit properties.

## 2D views

2D views	
Automatic update	Yes
Layer	VIEWS
Visible lines	
Show on sections	Yes
Line color	■ ByObject
Linetype	—— ByObject
Lineweight	—— ByObject
Hidden lines	
Show on views	No
Line color	■ ByObject
Linetype	— — —ГОСТ 2.303 4
Lineweight	—— 0,20 mm
Section border	
Settings differ from visible lines	No
Line color	■ ByObject
Linetype	—— ByObject
Lineweight	—— ByObject
Hatch	
Show	Yes
Face hatch	Type - [User-Defined]

### Automatic update

Sets the update mode 2D views

### Layer

It defines the layer which will be located 2D views

### Visible lines

#### Show on sections

Adjusts the image visible lines on sections

#### Line color

Specifies the color of visible lines

#### Linetype

Specify the type of visible lines

#### Lineweight

It determines the weight of visible lines

### Hidden lines

#### Show on sections

It adjusts the display of invisible lines on 2D views

#### Line color

Specifies the color of hidden lines

#### Linetype

Specify the type of hidden lines

#### Lineweight

It determines the weight of invisible lines

## Section border

### Settings differ from visible

It determines whether the parameters are different boundary lines of the section visible lines  
If not, the next line settings are not valid.

### Line color

Specifies the color of the boundary line section

### Linetype

Specifies the type of the boundary line section

### Lineweight

It determines the weight of the boundary line section

## Hatch

### Show

It controls the display of hatching

### Face hatch

Settings such as shading

## 3D. Pseudo section properties

[-]  Pseudo section properties	
[-]  Hatch	
Show	Yes
Face hatch	Type - [User-Defined]
Surface transparency	0

## Hatch

### Show

It controls the display of hatching.

### Face hatch

Settings such as shading.

### Surface transparency

Settings such as shading. Default 0 - full transparency.

## 3D History



Main menu: **3D -  3D History...**



Ribbon: **3D Tools - Modeling -  3D History.**



Functional panel: **3D History.**



Command line: **SHOWTAB3DHISTORYNET.**



Command line: **TABS - select "3D History".**

When working in the 3D-design environment, a functional panel containing the model building tree is displayed on the screen.

**Building tree** - sequence of objects (actions) that make up the model.

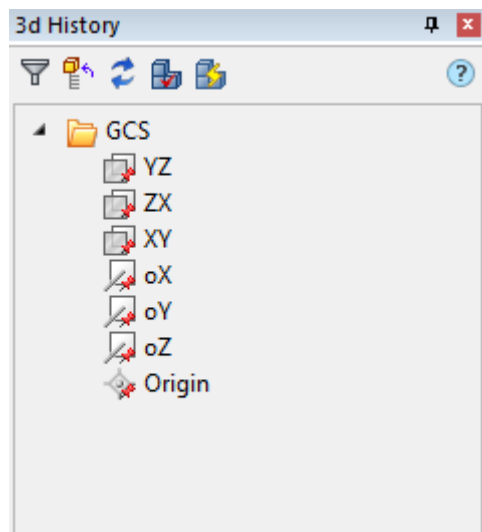

## Interface

The build tree contains a set of tools:

 **Filter Items** - massively hides all working objects: planes, axes, points.

 **Update tree** - updates the tree.

 **Expand parts** - expands all branches in the tree.

 **Expand parts with errors** - expands branches of parts that have errors.

 **Collapse parts** - collapses all expanded branches in the tree.

 **Update model with regen**(3drebuild) - rebuild model.



 **Update model**(mchist3dupdate) - update model.

 **Assembly properties** - opens the "**Properties of an assembly unit**" dialog, where the data of the selected object for the specification is specified.

## Objects of a tree



 - root folder "**GCS**" (General Coordinate System).

The following objects are bound to it:



-  - planes YZ, ZX, XY. By default, they are hidden and have a gray icon .

The following shortcut menu commands are available:

- **Hide** - hides the mapping of the plane in model space.
- **Show** - shows the mapping of the plane in model space.
- **ShowInDocument** - focuses the plane in the center of the model space. The command is available when the plane is displayed.

- **Create 2d-sketch** - call command ["Add planar sketch"](#). Sketch drawing plane is not necessary.
-  - axis oX, oY, oZ. By default, they are hidden and have a gray icon .

The following shortcut menu commands are available:

- **Hide** - the command hides the display of the axis in model space.
- **Show** - the command displays the axis in model space.
- **ShowInDocument** - the team focuses the axis in the center of the model space. The command is available when the axis is displayed.
-  - origin. Default is hidden and has a gray icon .

The following shortcut menu commands are available:

- **Hide** - the command hides the display of the origin in the model space.
- **Show** - the command shows the display of the origin in the model space.
- **ShowInDocument** - the team focuses the origin in the center of the model space. The command is available when the origin is displayed.

 - root folder **"Sections"**.























The following objects are bound to it:

-  - [Section](#). Has child objects  [View](#), taken from section.



 - [Planar sketch](#). When applied to it, 3D Operations is bound to an operation (becomes its child element) and the icon becomes inactive. An exception - [assembly sketch](#).

 - Part. It is a 3D object. Sheet bodies have their own icon .

The following objects can be attached to the part:



-  ["Planar sketch"](#).
-  ["Work plane"](#). Can be located in the root of the tree and enter the structure of objects  **"Part"**.
-  ["Work axis"](#). Can be located in the root of the tree and enter the structure of objects  **"Part"**.
-  ["Work point"](#). Can be located in the root of the tree and enter the structure of objects  **"Part"**.
-  ["McExtrudeFeature"](#). 3D operation.
-  ["McRevolveFeature"](#). 3D operation.
-  ["McSweepFeature"](#). 3D operation.
-  ["McLoftFeature"](#). 3D operation.
-  ["Union"](#). Contains the union parts.
-  ["Intersect"](#). Contains the intersect parts.
-  ["Subtract"](#). Contains the subtract parts.
-  ["McChamferFeature"](#).
-  ["McFilletFeature"](#).
-  ["McMirrorFeature"](#).
-  ["McRectangularPatternFeature"](#).
-  ["McCircularPatternFeature"](#).
-  - 3D constraints.
-  Nonparametric solid.
-  End of builds. The object indicates the end of the body construction.



The following shortcut menu commands are available for the object  **"Part"**:

- **Rename (F2)** - allows you to rename the part.
- **Delete (Del)** - removes the part and child objects from the tree and model space.
- **Hide** - hides the part and child objects from the model space.
- **Show** - shows the part and child objects in the model space.
- **Fix** - fixes the part in space. You can not move (3D Move), rotate (3D Rotate) or align (3D Align). The part acquires an icon with an anchor .
- **Unfix** - de-fixes the part. You can move (3D Move), rotate (3D Rotate) or align (3D Align).
- **ShowInDocument** - focuses and highlights the part in the center of the model space.
- **Rebuild** - rebuilds an object in model space.
- **Create detail**  - creates a detail from the part, internal objects are hidden. The detail is a 3d block.

 Detail - the object is a 3D block.

The following shortcut menu commands are available for the object  **"Detail"**:

- **Open in editor** - opens the 3D block editor.
- **Edit in place** - opens the 3D reference editor.
- **Rename (F2)** - allows you to rename the detail.
- **Delete (Del)** - removes the detail and child objects from the tree and model space.
- **Hide** - hides the detail and child objects from the model space.
- **Show** - shows the detail and child objects in the model space.
- **Fix** - fixes the detail in space. You can not move (3D Move), rotate (3D Rotate) or align (3D Align). The detail acquires an icon with an anchor .
- **Unfix** - de-fixes the detail. You can move (3D Move), rotate (3D Rotate) or align (3D Align).
- **ShowInDocument** - focuses and highlights the detail in the center of the model space.
- **Rebuild** - rebuilds an object in model space.
- **Disband** - breaks a detail (assembly) into its component parts.
- **Create assembly** - the command is active when two or more parts (details, assemblies) are selected and creates an assembly unit . The assembly is a 3d block.
- **Properties** - command opens the **"Properties"** dialog.

 Assembly - an object is a 3d block that includes several units of parts, bodies, assemblies. Context menu commands are similar to the object  **"Detail"**:

## Modeling modes

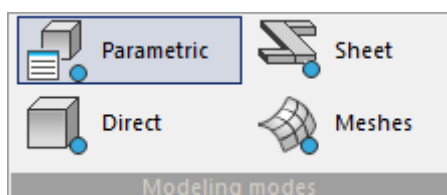

Various types of modeling are used in the design process: Parametric, Direct, Sheet, Meshes.

Placing all of the commands for these types of modeling on the same tab at the same time creates confusion.

For the convenience of designing, the **"Modeling modes"** ribbon block has been added, which includes the following commands:

 Ribbon: **3D Tools - Modeling modes** -  **Parametric**.

 Command line: 3DDRAFTINGMODE0.



Opens ribbon blocks "**Parametric Modeling**", "**2D Sketch**".



 Ribbon: **3D Tools - Modeling modes** -  **Direct**.

 Command line: 3DDRAFTINGMODE1.

Opens ribbon block "**Direct Modeling**".



 Ribbon: **3D Tools - Modeling modes** -  **Sheet**.

 Command line: 3DDRAFTINGMODE2.

Opens ribbon blocks "Sheet solids", "2D Sketch".

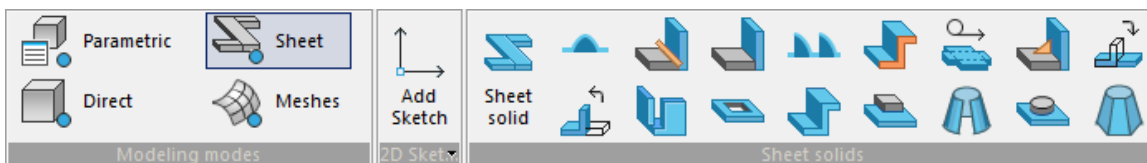

 Ribbon: **3D Tools - Modeling modes** -  **Meshes**.

 Command line: 3DDRAFTINGMODE3.

Opens ribbon block "Mesh".

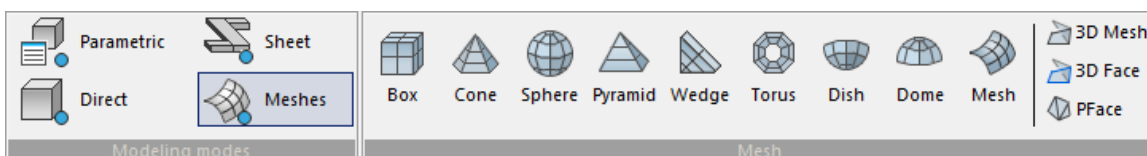

## Sketch mode

### Add planar sketch

 Main menu: **3D - 2D Sketch** -  **Add planar sketch**.

 Ribbon: **3D Tools - 2D Sketch** -  **Add sketch**.

 Toolbar: **3D - Add planar sketch**.

 Command line: **PSADD**.

There are 2 ways to create a sketch, with a reference to the plane and without binding.

With a sketch without binding, a 3D operation is created in the new unfixed body.

From the sketch with reference to the plane of the body, a 3D operation is created with a binding to the body.

From a sketch bound to a plane that does not belong to the body, a 3D operation is created in the new fixed body without the possibility of de-fixing.

### **Important!**

When creating a sketch that will serve as a cross-section for 3D design operations, it is important to remember that the sketch must be a closed loop.

### *Creating a sketch without a reference to the plane*

Sketching without reference to a plane is done in the XY plane.

1. Draw a sketch.

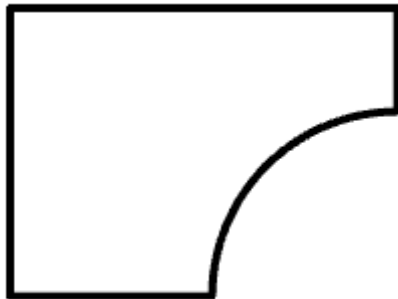

2. Select all sketch entities.

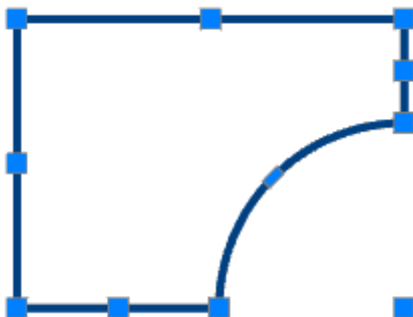

3. Call command  **"Add planar sketch"**. The system automatically sets the desired view orientation. All the available objects in the sketch will be transferred from the selected objects.

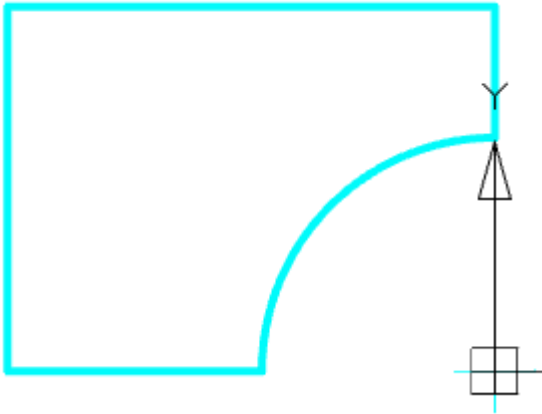

4. [Finish sketch editing.](#)



5. A sketch without reference to a plane will be created and added to ["3D History"](#).

***Creating a sketch with a reference to the plane***

1. Call command  **"Add planar sketch"**.
2. Select the sketch creation plane. This can be a plane GCS, any working plane, as well as a flat surface of the body. The system automatically sets the desired orientation of the view - normal to the selected plane.
3. Draw a sketch.

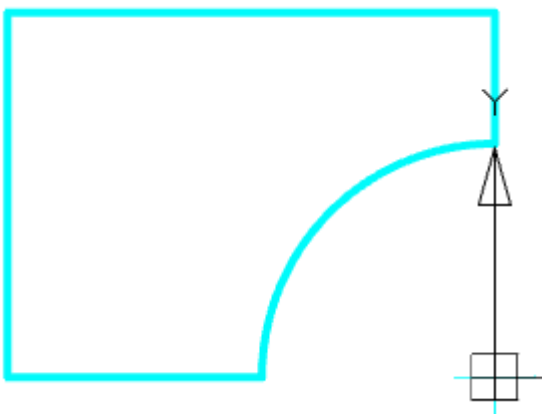

For convenience, in sketch editing mode, the ribbon contains all the necessary commands to draw a sketch, edit its geometry, project some face, or complete sketch editing.

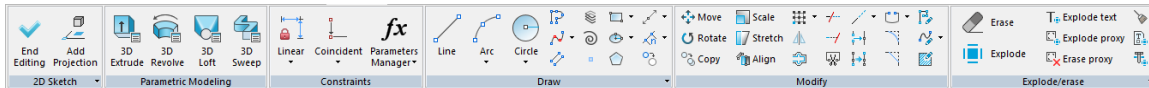

#### 4. [Finish sketch editing.](#)



5. A sketch with a reference to the plane will be created and added to ["3D History"](#).

### *Properties*

Does not have individual properties.

### *Grips*

■ **Moving grip** - is used to move the sketch in model space.

### *3D History*

 **"Planar sketch"**. When creating Planar sketch is located in the root of the tree. When applied to it, 3D Operations is bound to an operation (becomes its child element) and the icon becomes inactive. An exception - [Assembly sketch](#).

The following shortcut menu commands are available:

- **Edit** - Calls to edit the sketch. To the right of the icon appears the editing symbol .
- **End edit** - completes the previously started editing.
- **Rename (F2)** - allows you to rename a sketch.
- **Delete (Del)** - removes a sketch from the tree and model space.
- **Hide** - hides a sketch from the model space. The icon becomes inactive.
- **Show** - shows a sketch in model space. The icon becomes active.
- **Suppress** - removes the thumbnail from the model space. The icon becomes inactive. Suppressed elements are removed only from the model space, while they remain in the build tree. After suppressing the element, the model will be rebuilt without taking into account the excluded elements and their derivatives.
- **Unsuppress** - restores a sketch in model space.
- **ShowInDocument** - focuses and highlights the sketch in the center of the model space.
- **Rebuild** - rebuilds the object in model space.

## *Add assembly sketch*



Main menu: **3D - 2D Sketch -  Add assembly sketch.**



Toolbar: **3D -  Add assembly sketch.**



Command line: **PSADDASM.**

The command is similar ["Add planar sketch"](#).

### *Differences of the assembly sketch*

- the assembly sketch is not included in any body, including in the model tree;
- the body constructed from the assembly sketch is automatically fixed in the last position without the possibility of a defect;
- the body built from the assembly sketch can only be moved together with the assembly sketch. You can only move the sketch.

### *Include object to sketch*



Main menu: **3D - 2D Sketch -  Include object to sketch.**



Ribbon: **3D Tools - 2D Sketch -  Include Object.**



Toolbar: **3D -  Include object to sketch.**



Command line: **PSINCL.**

The command is used to add objects not built in sketch mode to the sketch. The command is available in the mode of creating (editing) the sketch.

### *Procedure*

1. In sketch editing mode, call the command  **"Include object to sketch"**.

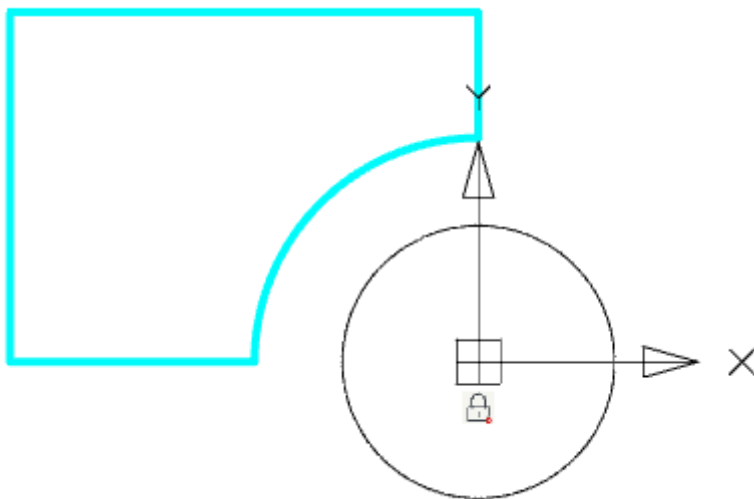

2. Specify the objects that you want to add to the sketch. The object is added to the sketch.

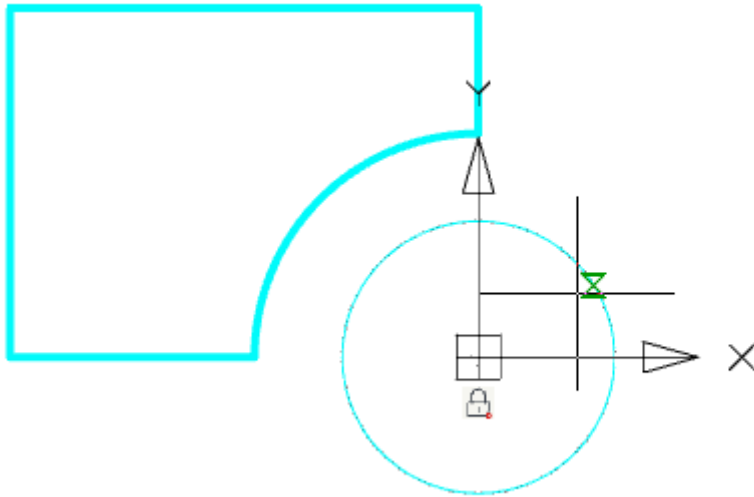

3. To exit the add mode, press **"Esc"**.

### ***Add projection to sketch***



Main menu: **3D - 2D Sketch - Add projection to sketch.**



Ribbon: **3D Tools - 2D Sketch - Add Projection.**



Toolbar: **3D - Add projection to sketch.**



Command line: **PSPROJ.**

The team projects geometry that is not built in sketch mode. It is also possible to project the geometry from the bodies. The command is available in the mode of creating (editing) the sketch.

### ***Procedure***

1. In sketch editing mode, call the command **Add projection to sketch**.

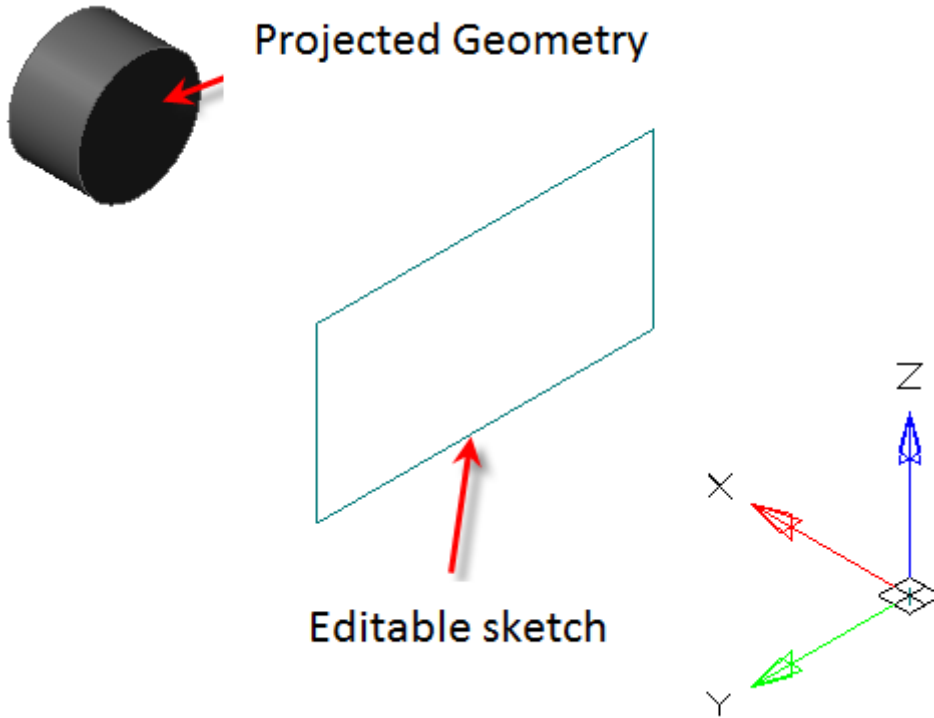

2. Sequentially indicate the edges of the object that you want to project. The projection is performed automatically immediately after the indication.

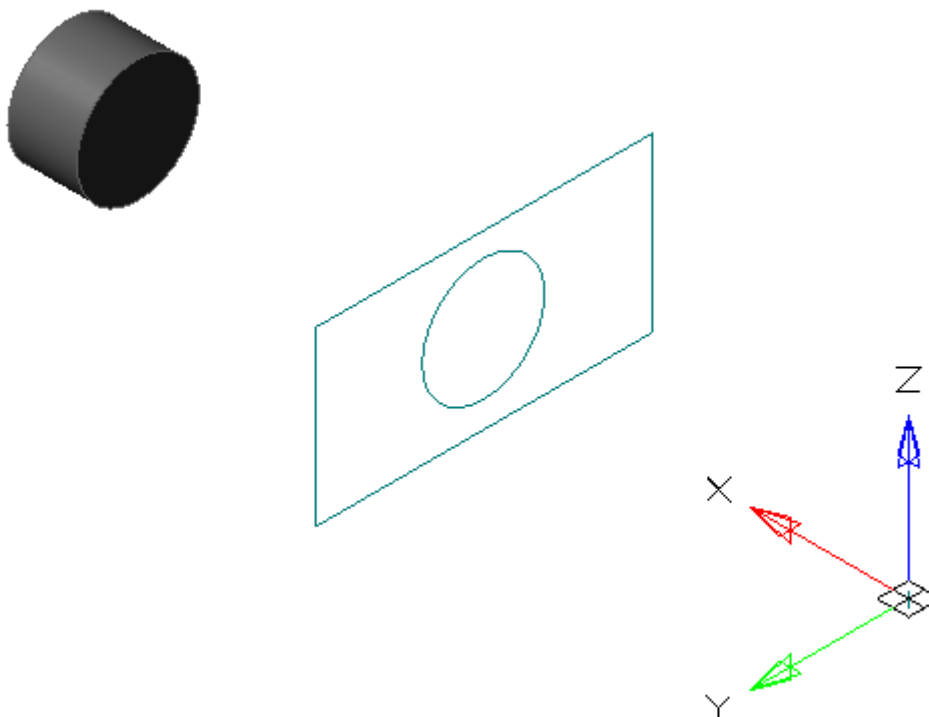

3. To exit the loop, press "**Esc**".

**Important!**

When you remove the projected geometry, the projection is removed along with the geometry.

## Features of work

Projected geometry in a sketch can be redefined to another of that type. In this case, all associative bindings are preserved.

To override you need:

1. Call the sketch for editing;

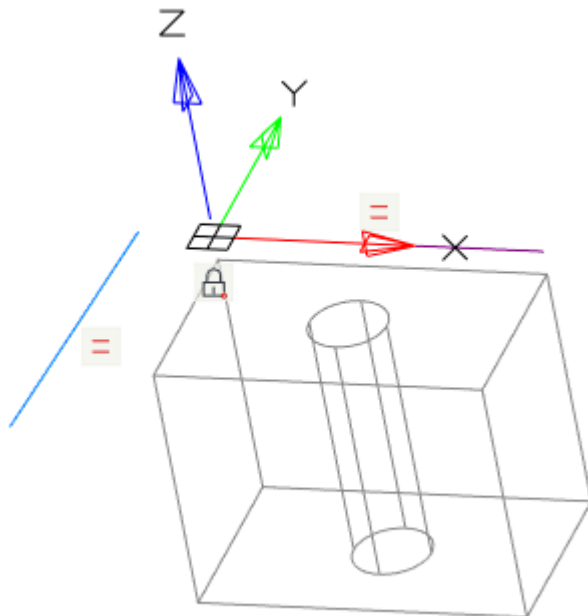

2. Select the projected geometry;

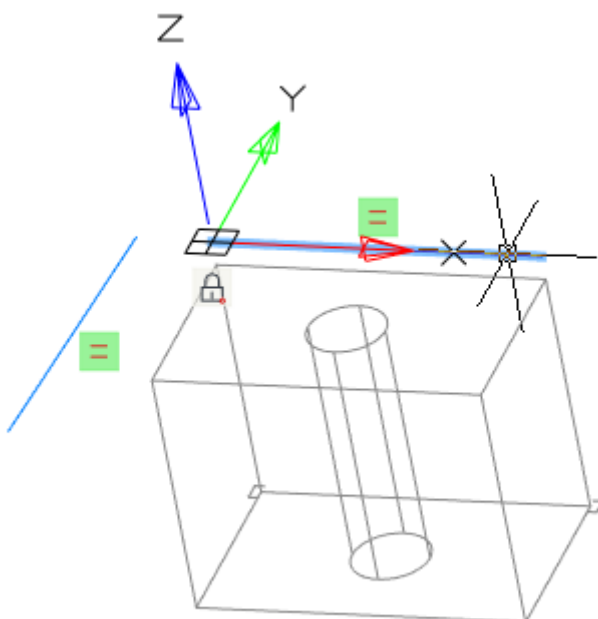

3. Call the RMB context menu and select the "**Redefine**" command;
4. Specify another edge of the object, it must have the same type (line, circle...);



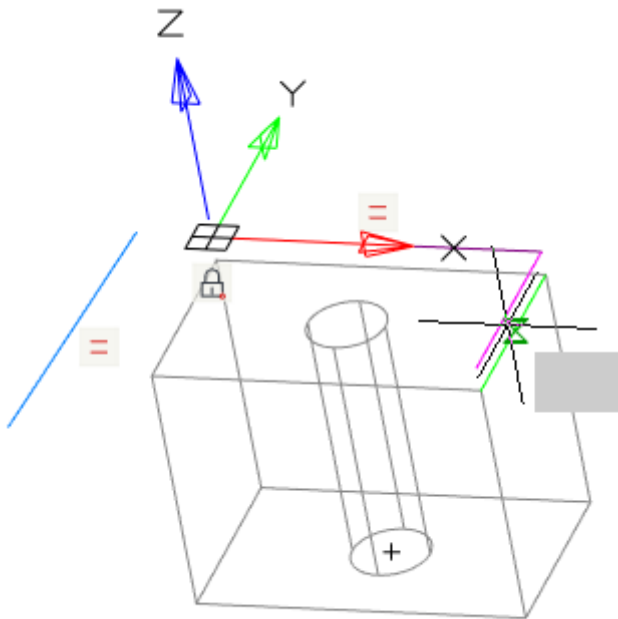

5. The geometry will be redefined. Associative links will be preserved.

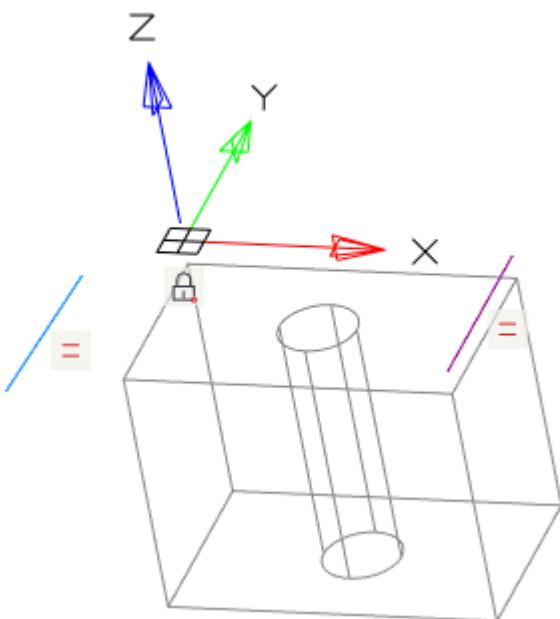

## *Redefine plane for sketch*

 Main menu: **3D - 2D Sketch -  Redefine plane for sketch.**

 Ribbon: **3D Tools - 2D Sketch -  Redefine Plane.**

 Toolbar: **3D -  Redefine plane for sketch.**

 Command line: **PSREDEFINE.**

The command changes the plane of the selected sketch to another flat surface or work plane.

## Procedure

1. Call command  **"Redefine plane for sketch"**.
2. Select in the model space or in the **"3D History"** sketch to move.

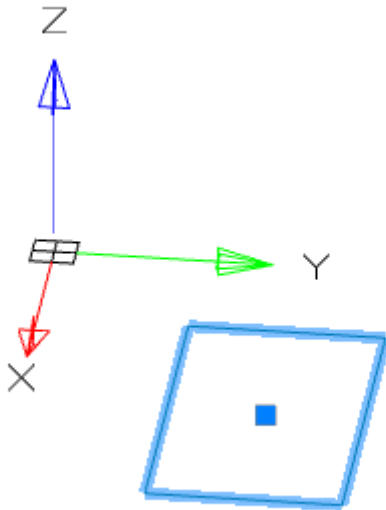

3. Select a new plane for the sketch in model space, in **"3D History"** or GCS plane from the context menu.

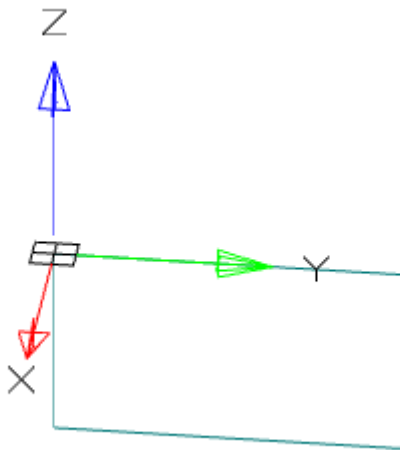

4. The sketch will be automatically moved to another plane.

## Set Sketch Coordinate System



Main menu: **3D - 2D Sketch -  Set Sketch Coordinate System.**



Ribbon: **3D Tools - 2D Sketch -  Set Sketch Coordinate System.**



Toolbar: **3D -  Set Sketch Coordinate System.**

 Command line: **PSDEFINECS**.

When you sketch on a planar face or work plane, the system automatically creates the sketch coordinate system. The "**Set Sketch Coordinate System**" command is required to edit the coordinate system of the selected sketch.

### *Procedure*

1. A sketch must first be created on a work plane or planar face.

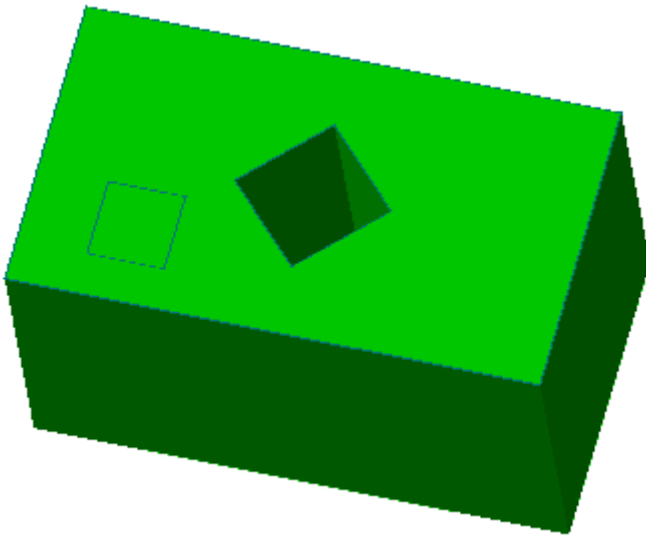

2. Call command  "**Set Sketch Coordinate System**" and specify a flat sketch if necessary.
3. The sketch coordinate system is displayed.

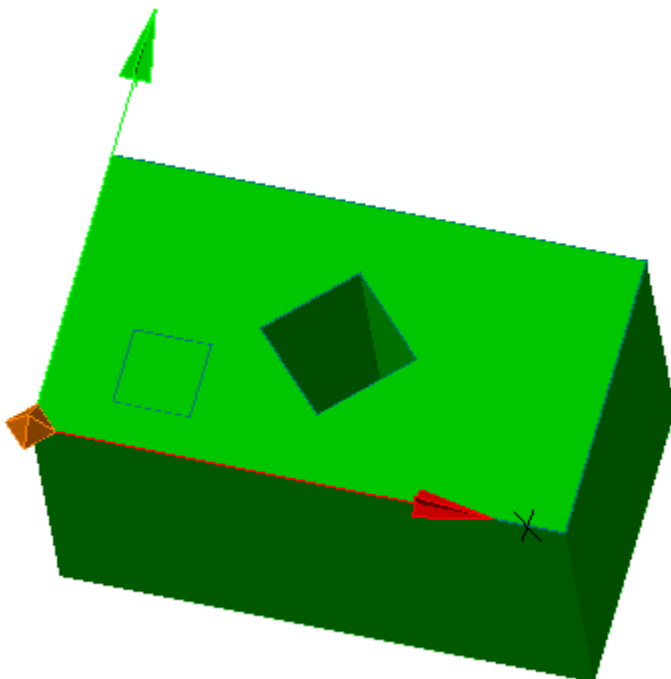

4. Select the item to change. The X, Y axis, or the origin point can be used as the element to change.

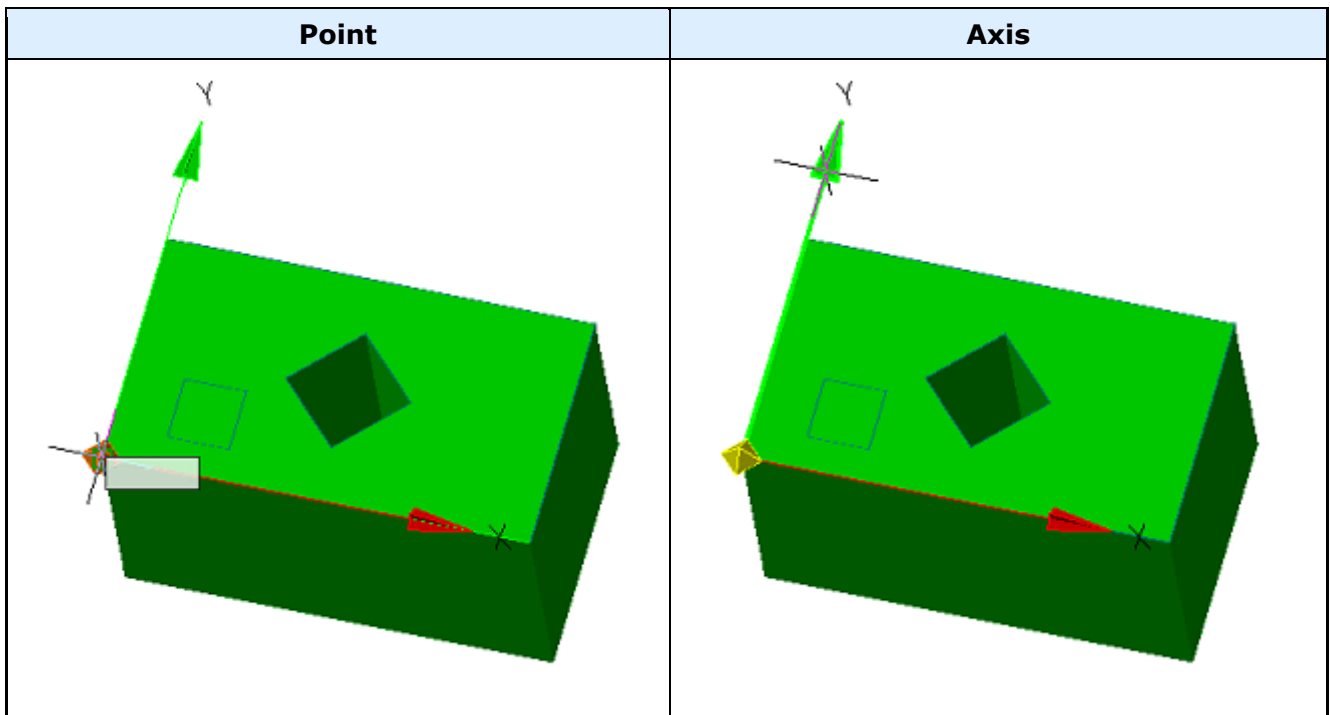

5. Pick a new position for the element. To change the origin, you need to specify a new point; to change the direction of the axis, you need to specify any straight edge. The position of the sketch relative to its coordinate system does not change.

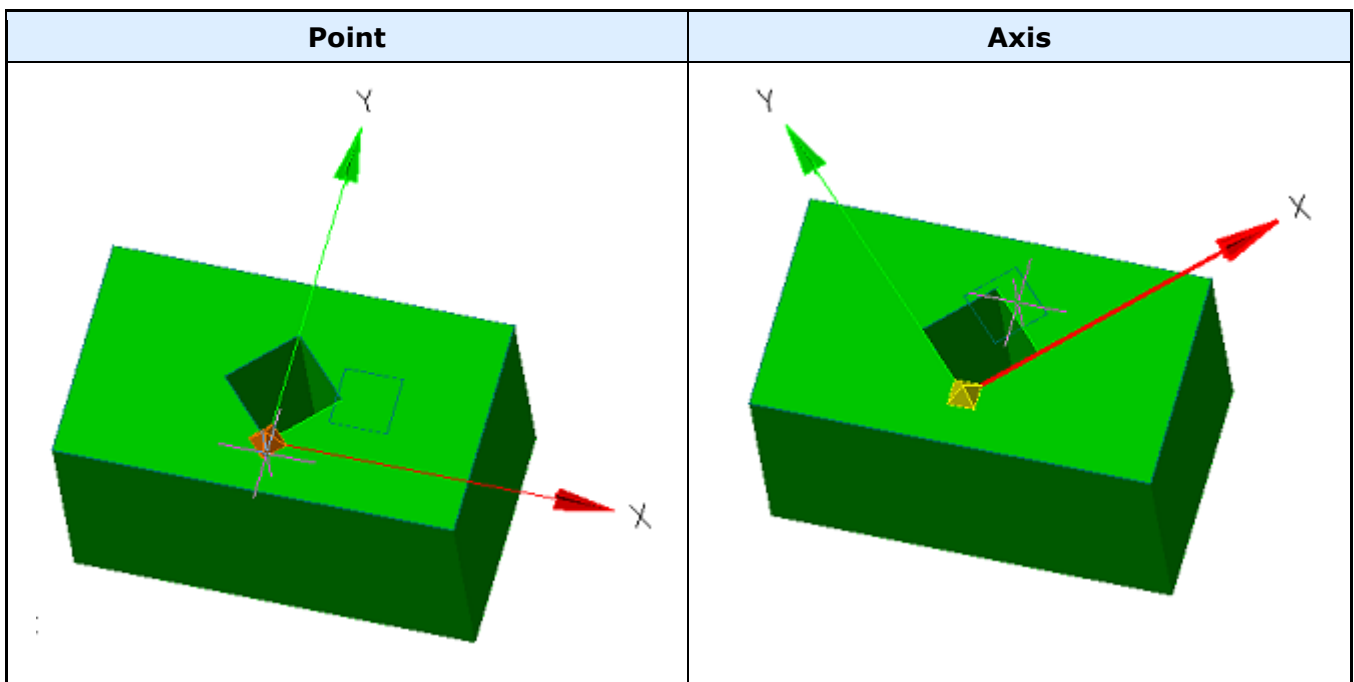

6. The sketch coordinate system will be changed.

### *Edit planar sketch*

 Main menu: **3D - 2D Sketch -  Edit planar sketch.**

 Ribbon: **3D Tools - 2D Sketch -  Edit sketch.**

 Toolbar: **3D -  Edit planar sketch.**

 Command line: **PSEDIT**.

 Context menu: **Command "Edit" on select sketch in "3D History"**.

The command switches to edit mode a flat sketch.

### *Procedure*

1. Specify in the model space or in the **"3D History"** sketch.
2. Call command  **"Edit planar sketch"**.
3. The sketch will go into edit mode.

### *End editing*

 Main menu: **3D - 2D Sketch - ✓ End editing**.

 Ribbon: **3D Tools - 2D Sketch - ✓ End editing**.

 Toolbar: **3D - ✓ End editing**.

 Command line: **PSENDEREDIT**.

The command finishes creating or editing a sketch.

## *Parametric modeling*

### *3D Extrude*

 Main menu: **3D - 3D Features -  3D Extrude**.

 Ribbon: **3D Tools - Modeling -  3D Extrude**.

 Toolbar: **3D -  3D Extrude**.

 Command line: **3DEXTRUDE**.

Tool for pulling a section along a straight path.

### *Procedure*

1. Create a Planar sketch (if it is not).
2. Call command  **"3D Extrude"**. Open dialog **"3D Extrude"**.

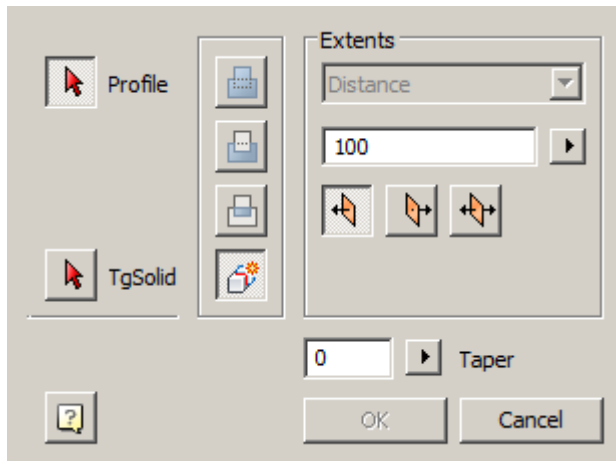

3. Specify the required options in the dialog box **"3D Extrude"**:

- Select the section sketch. Possible sketches are highlighted by horizontal hatching. The selected section is highlighted by vertical shading. The sketch must be a closed loop.

**Note:**

If you have already selected a section from one sketch, and you want to select another section from another sketch, you must first deselect the section you have already selected.

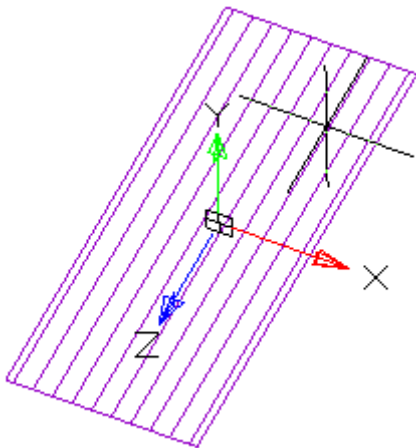

Simultaneously with the selection of the section, a contour of the extruded section appears - a preview of the result of the operation.

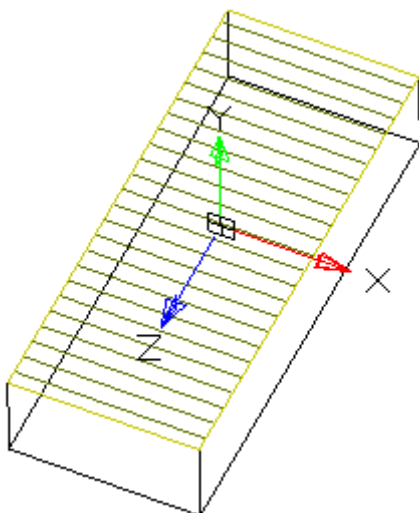



- Set the extrusion distance.
- Choose a direction: Positive, Negative, Both directions.

- Specify, if necessary, the slope of the extrusion.

4. Press button **"OK"**. The operation will be carried out. If the **"OK"** button is not active, then the sketch was not selected or the parameters were incorrectly set. In the **"3D History"** will be created object  **"McExtrudeFeature"**, containing a sketch, linked to an existing or a new body.

## Dialog





Button  **"Profile"** - allows you to select in the model space or in the **"3D History"** sketch.

Button  **"TgSolid"** - allows you to specify the parent body for the sketch.



Switch **"New body is associative"** - controls the settings parameter **"Associativity when creating new bodies"**. The enabled

option allows you to build fixed bodies without the possibility of defixation.

A group of operation action selectors:

-  **"Join"** - creates a new extrusion object in the previously created body. The sketch must belong to the body.
-  **"Cut"** - creates a cutout with the outline of the selected sketch (for example, holes). When cutting, the dimension selection field becomes active, allowing you to select the cut length to a distance or through. The sketch must belong to the body.
-  **"Intersect"** - creates an object to intersect the contours of the new sketch and the previously created body. The sketch must belong to the body.
-  **"New body"** - creates a new extrusion object. A new body appears in the tree of constructions. When a switch is selected, the previously selected sketch belonging to the body is detached from the body.

Extends:

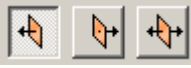
-  **"The field for selecting the type of dimension"**. Distance - extrusion, cutting or intersection is specified by the distance. All - cutting is carried out through the whole body, the distance input field is unavailable.
- Field   **"Distance"** - allows you to specify the distance. To the right of the field, there is a button to indicate the distance from the drawing.
-  **"Group of direction selection switches"** - controls the direction of extrusion relative to the sketch plane.

 **Positive direction** - directs the extrusion towards the positive direction of the axis perpendicular to the plane of the sketch.

 **Negative direction** -directs the extrusion towards the negative direction of the axis perpendicular to the plane of the sketch.

 **Both direction** - directs extrusion in both directions relative to the sketch plane by the same distance.

Field   **"Angle of slope"** - allows you to specify the angle of inclination. The operation creates a body tapering to a point. To the right of the field there is a button for specifying the angle from the drawing.

**Note:** When choosing the faces of an existing body for building 3D-operations, it is recommended to disable the **Center** binding in order to avoid incorrect work.

### Select new body

There are two bodies: a cylinder and a parallelepiped. On the upper plane of the cylinder a sketch is created, which is a circle whose center is located between these bodies.

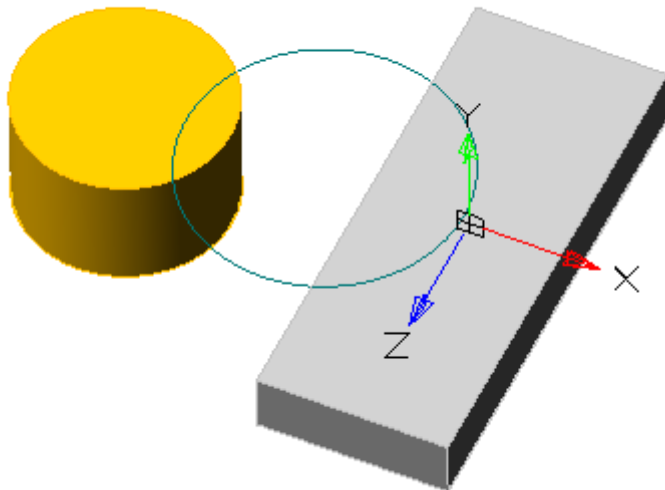

Call the **"3D Extrude"** dialog and select this circle as the sketch. As an action, select **"Cut"**. By default, the sketch belongs to the body on whose plane it was built, in this case the cylinder. Correspondingly, the cutting will be performed for the cylinder.

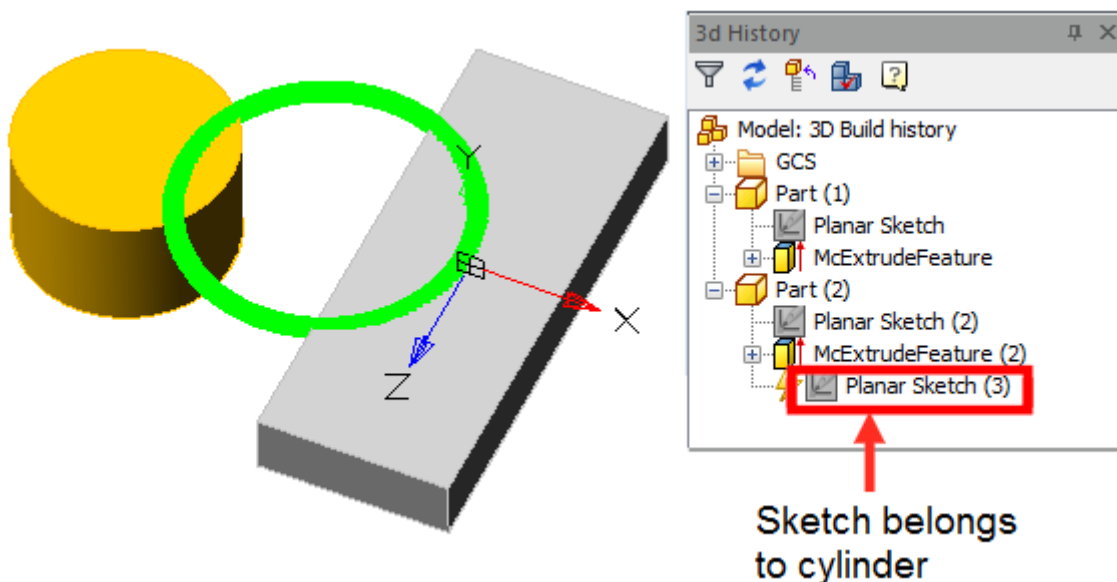

By default, the body of the cylinder is selected.



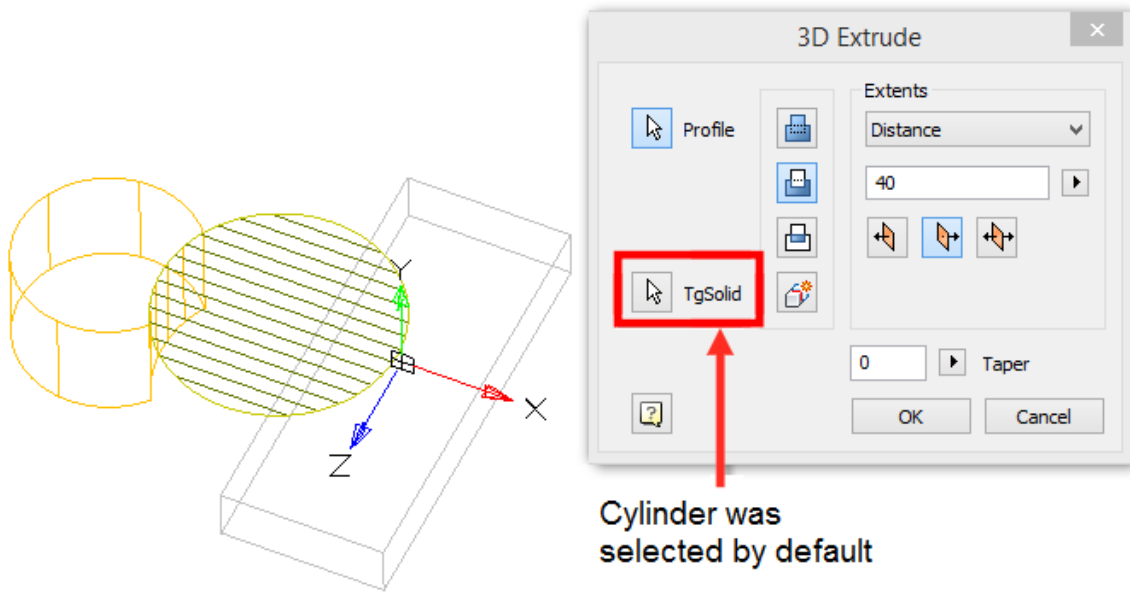

Assign a new body to the parallelepiped, for which we click on the button **"TgSolid"** and the LMC we select a parallelepiped.

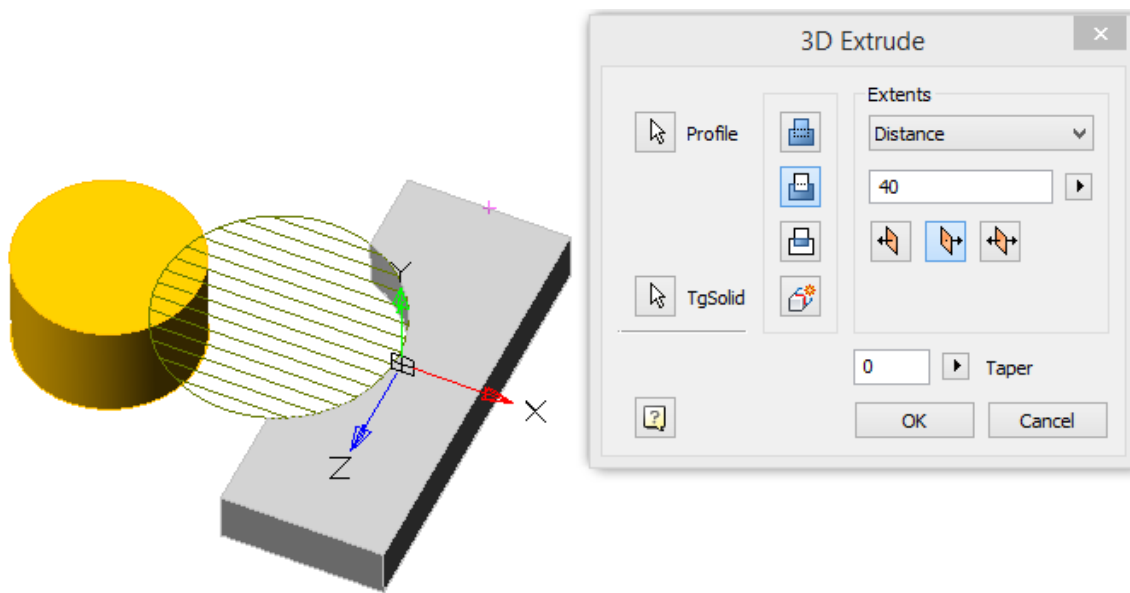

Result: the sketch belongs to the body of Parallelepiped, is part of its tree, and makes a cutout in its body.

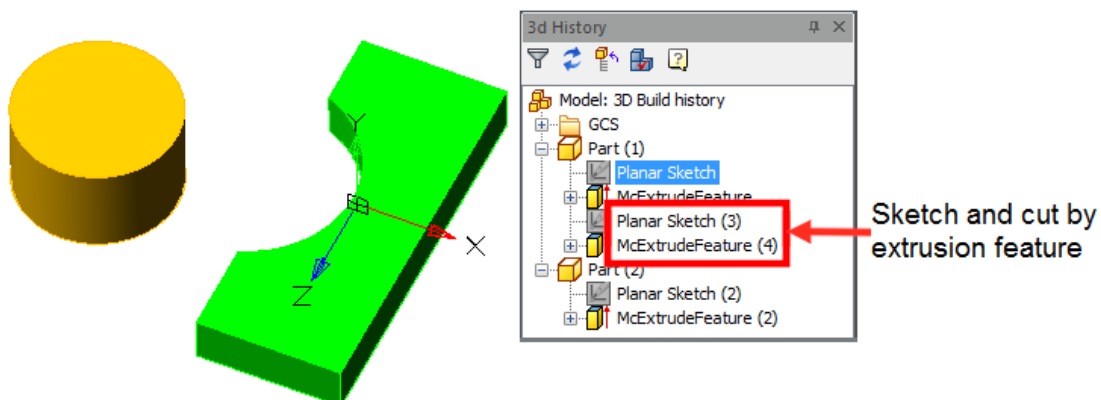

## 3D History

 **"McExtrudeFeature"**. It is part of the body.

The following shortcut menu commands are available:

- **Edit** - calls for editing a 3D operation. To the right of the icon appears the editing symbol ⚡.
- **End edit** - completes the previously started editing.
- **Rename (F2)** - allows you to rename a 3D operation.
- **Delete (Del)** - removes the 3D operation and child objects from the tree and model space.
- **Suppress** - removes the 3D operation and child objects from the model space.
- **Unsuppress** - restores a 3D operation in model space.
- **ShowInDocument** - focuses and highlights the 3D operation in the center of the model space.
- **Rebuild** - rebuilds the object in model space.

## 3D Revolve



Main menu: **3D - 3D Features -  3D Revolve.**



Ribbon: **3D Tools - Modeling -  3D Revolve.**



Toolbar: **3D -  3D Revolve.**



Command line: **3DREVOLVE.**

Tool for drawing a section along a path in the form of a circle or a circular segment.

### Procedure

1. Create a Planar sketch (if it is not).
2. Create a working axis, if necessary, around which the rotation will take place. The face of the body can also serve as an axis.
3. Call command  **"3D Revolve"**. Open dialog **"3D Revolve"**.

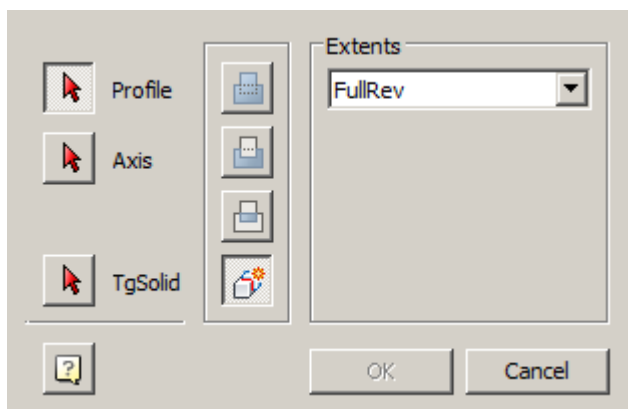

4. Specify the required options in the dialog box **"3D Revolve"**:

- Select the section sketch. Possible sketches are highlighted by horizontal hatching. The selected section is highlighted by vertical shading. The sketch must be a closed loop.

**Note:** If you have already selected a section from one sketch, and you want to

select another section from another sketch, you must first deselect the section you have already selected.

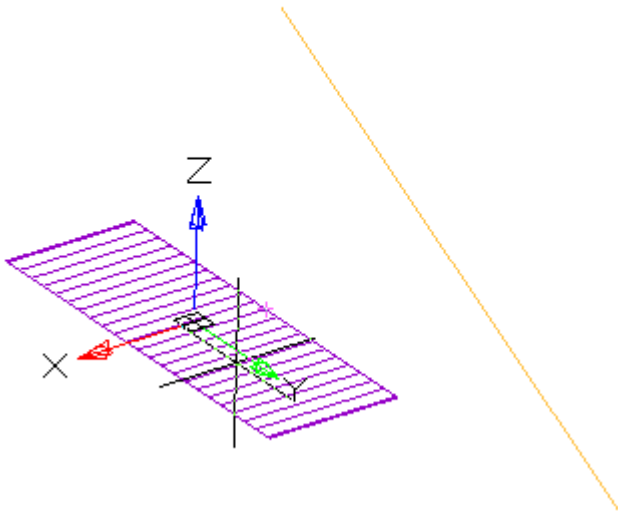

- Select the axis of rotation. You can select the line in the drawing, including the line that is part of the sketch, as well as the edge of the body. A preview of the results of the operation appears.
- Set the rotation angle and direction if necessary.

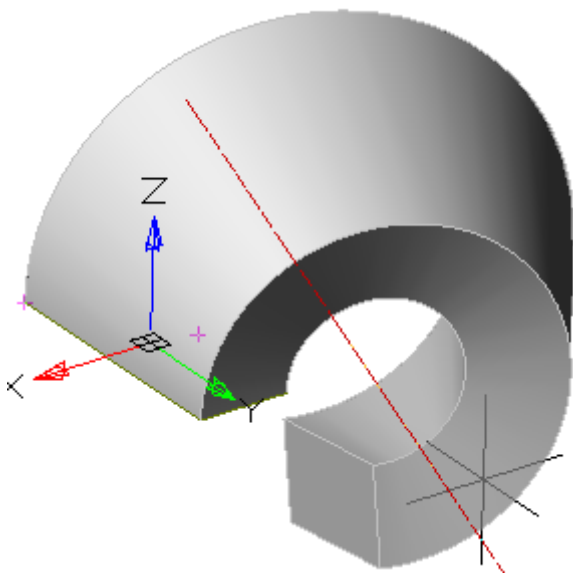



5. Press button **"OK"**. The operation will be carried out. If the **"OK"** button is not active, then the sketch, axis, or incorrect parameters were not selected. In the **"3D History"** will be created object  **"McRevolveFeature"**, a sketch containing a sketch, linked to an existing or a new body.

**Note:** When choosing the faces of an existing body for building 3D-operations, it is recommended to disable the **Center** binding in order to avoid incorrect work.

## Dialog





Button  **"Profile"** - allows you to select in the model space or in the **"3D History"** sketch.

Button  **"Axis"** - allows you to select the axis of rotation in the model space or in the **"3D History"**.



Button  **"TgSolid"** - allows you to specify the parent body for the sketch (for more information about the function, see [Extrude](#)).

Switch **"New body is associative"** - controls the settings parameter **"Associativity when creating new bodies"**. The enabled option allows you to build fixed bodies without the possibility of defixation.

A group of operation action selectors:

-  **"Join"** - creates a new object by rotating in the previously created body. The sketch must belong to the body.
-  **"Cut"** - creates a cutout by rotating the selected sketch (for example, holes). The sketch must belong to the body.
-  **"Intersect"** - creates an object to intersect the contours of the new sketch and the previously created body. The sketch must belong to the body.
-  **"New body"** - creates a new rotation object. A new body appears in the tree of constructions. When a switch is selected, the previously selected sketch belonging to the body is detached from the body.

Extents:

-  **"The field for selecting the type of dimension"**. RevAngle - rotation is given by the angle. FullRev - rotation is performed on a full circle.
- Field   **"Angle"** - allows you to specify the rotation angle. To the right of the field there is a button for specifying the angle from the drawing.
-  **"Group of direction selection switches"** - controls the direction of extrusion relative to the sketch plane.

 **Positive direction** - directs the rotation toward the positive direction of the axis perpendicular to the plane of the sketch.

 **Negative direction** - directs the rotation toward the negative direction of the axis perpendicular to the plane of the sketch.

 **Both direction** - directs the rotation in both directions relative to the sketch plane by the same distance.

## 3D History

 **"McRevolveFeature"**. It is part of the body.

The following shortcut menu commands are available:

- **Edit** - calls for editing a 3D operation. To the right of the icon appears the editing symbol .
- **End edit** - completes the previously started editing.
- **Rename (F2)** - allows you to rename a 3D operation.
- **Delete (Del)** - removes the 3D operation and child objects from the tree and model space.
- **Suppress** - removes the 3D operation and child objects from the model space.
- **Unsuppress** - restores a 3D operation in model space.
- **ShowInDocument** - focuses and highlights the 3D operation in the center of the model space.
- **Rebuild** - rebuilds the object in model space.

## 3D Sweep

 Main menu: **3D - 3D Features - 3D Sweep**.

 Ribbon: **3D Tools - Modeling - 3D Sweep**.

 Toolbar: **3D - 3D Sweep**.

 Command line: **3DSWEEP**.

Tool for drawing a section along a previously trajectory.

### Procedure

1. Create a Planar sketch (if not).
2. Create a path along which the section will be drawn. The trajectory must be drawn in another sketch mode in the orthogonal plane to the section plane.
3. Call command  **"3D Sweep"**. Open dialog **"3D Sweep"**.

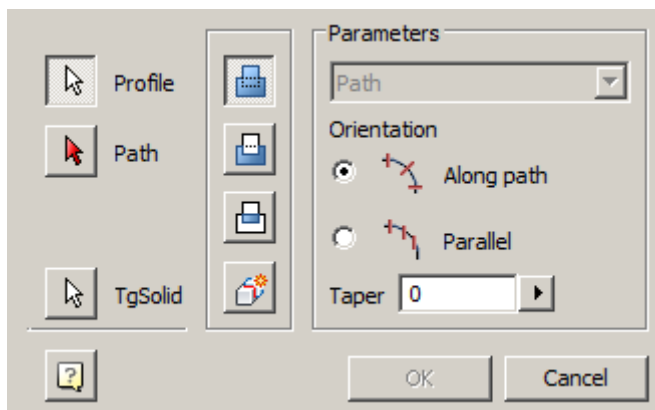

4. Specify the required options in the dialog box **"3D Sweep"**:

- Select the section sketch. Possible sketches are highlighted with purple fill. The sketch must be a closed loop.

**Note:**

If you have already selected a section from one sketch, and you want to select another section from another sketch, you must first deselect the section you have already selected.

The selected section is highlighted with a green fill.

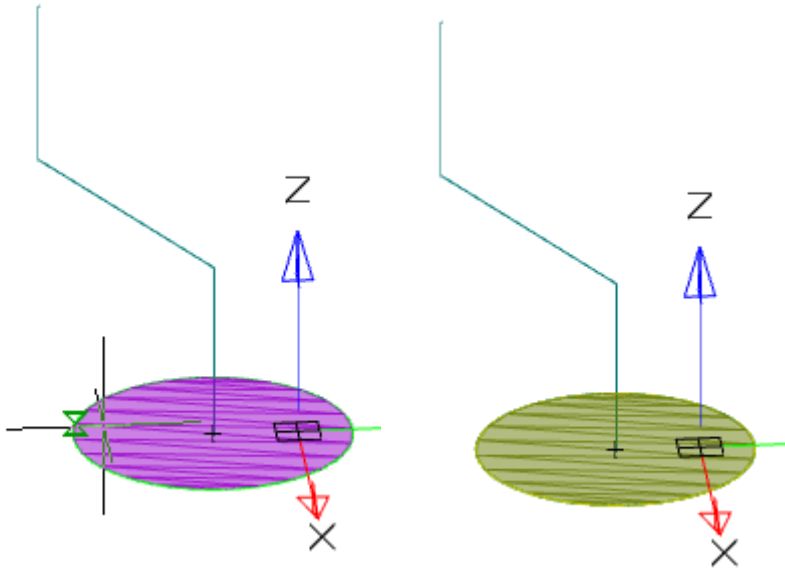

- Select a path. If the path is a polyline or a combination of individual lines, you must select a path in sequence. To exclude from the sequence an incorrectly selected path segment, you must click on it LMC + Shift.

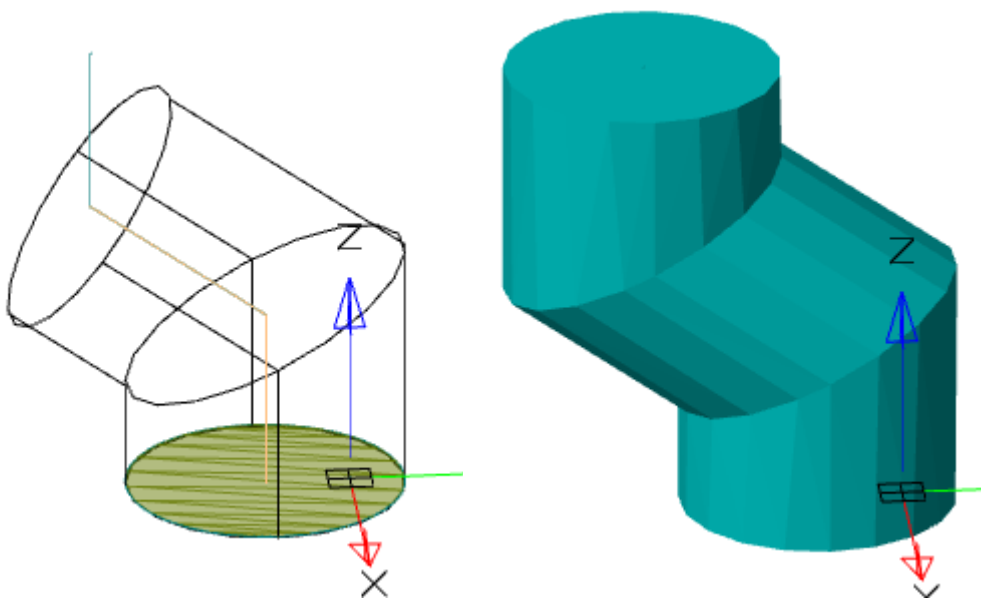

- Select an orientation.

<b>Along path</b>	<b>Parallel</b>
-------------------	-----------------

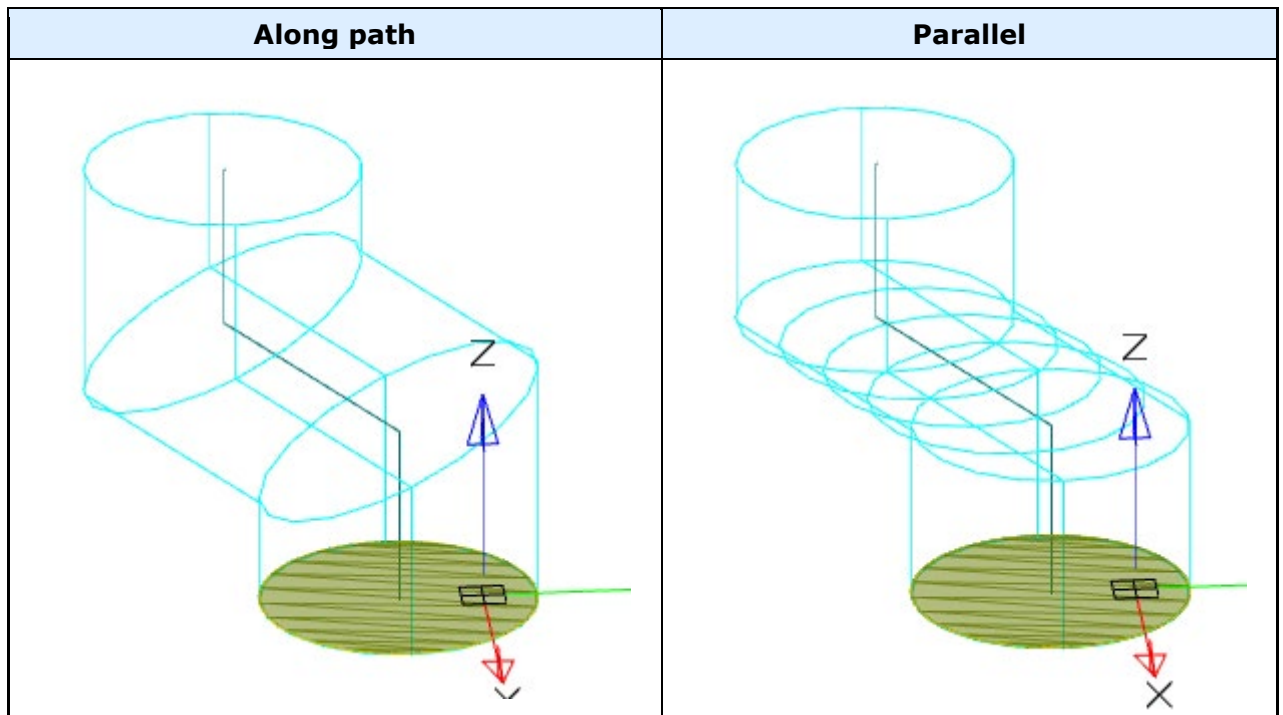

- If necessary, specify the broadening (if the orientation is selected along the path).

5. Press button **"OK"**. The operation will be carried out. If the **"OK"** button is not active, then the sketch, the trajectory was not selected, or the parameters were incorrectly set. In the **"3D History"** will be create object  **"McSweepFeature"**, containing a sketch and trajectory, with reference to an existing or a new body.

**Note:**

When choosing the faces of an existing body for building 3D-operations, it is recommended to disable the **Center** binding in order to avoid incorrect work.

### Dialog





Button  **"Profile"** - allows you to select in the model space or in the **"3D History"** sketch.

Button  **"Path"** - allows you to select a trajectory in the model space or in the **"3D History"**.

Button  **"TgSolid"** - allows you to specify the parent body for the sketch (For more information about the function, see [Extrude](#)).

Switch **"New body is associative"** - controls the settings parameter **"Associativity when creating new bodies"**. The enabled option allows you to build fixed bodies without the possibility of defixation.

A group of operation action selectors:

-  **"Join"** - creates a new draw object in the previously created body. The sketch must belong to the body.
-  **"Cut"** - creates a cutout by drawing out the selected sketch (for example, holes). The sketch must belong to the body.
-  **"Intersect"** - creates an object to intersect the contours of the new sketch and the previously created body. The sketch must belong to the body.
-  **"New body"** - creates a new draw object. A new body appears in the tree of constructions. When a switch is selected, the previously selected sketch belonging to the body is detached from the body.

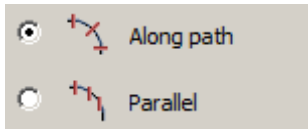

Parameters:

-  **"The field for selecting the type of dimension"**. Path - The pull length is given by the path. The field is not active.
- Radiogroup **"Orientation"** - controls the orientation of the sketch sections: Along path - sections are drawn perpendicular to the path line; Parallel - sections are built parallel to the sketch.





- Field   **"Taper"** - allows you to specify the angle of broadening. To the right of the field there is a button for specifying the angle from the drawing. The field is active when the track is oriented.

### 3D History

 **"McSweepFeature"**. It is part of the body. Contains sketch and  **"Path"**.

The following shortcut menu commands are available for the object  **"McSweepFeature"**:

- **Edit** - calls for editing a 3D operation. To the right of the icon appears the editing symbol .
- **End edit** - completes the previously started editing.
- **Rename (F2)** - allows you to rename a 3D operation.
- **Delete (Del)** - removes the 3D operation and child objects from the tree and model space.
- **Suppress** - removes the 3D operation and child objects from the model space.
- **Unsuppress** - restores a 3D operation in model space.
- **ShowInDocument** - focuses and highlights the 3D operation in the center of the model space.
- **Rebuild** - rebuilds an object in model space.

The following shortcut menu commands are available for the object  **"Path"**:

- **Edit** - causes editing of the trajectory.
- **End edit** - completes the previously started editing.
- **Hide** - hides the trajectory from the model space.
- **Show** - shows the trajectory in the model space.
- **ShowInDocument** - focuses and highlights the trajectory in the center of the model space.
- **Rebuild** - rebuilds an object in model space.

### 3D Loft

 Main menu: **3D - 3D Features** -  **3D Loft**.

 Ribbon: **3D Tools - Modeling** -  **3D Loft**.

 Toolbar: **3D** -  **3D Loft**.

 Command line: **3DLOFT**.

Tool for drawing bodies with different sections.

### Procedure

1. Create Planar sketches with sections.



2. Call command  **"3D Loft"**. Open dialog **"3D Loft"**.

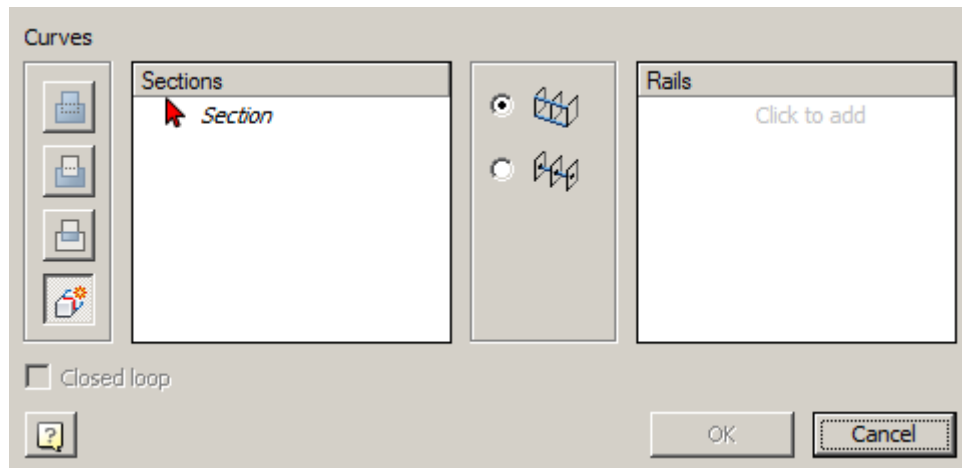

3. Specify the required options in the dialog box **"3D Loft"**:

- Select the first section. The sketch of a section must be a closed contour. The first section in the list can not be deleted. By clicking the **"Delete"** button, the geometry set for this section is cleared. After that, the geometry can be selected again. In the dialog, changing the color of the arrow means that the contour of the section is selected and you can proceed to select the next forming section.
- Add the following sections. To add a section, click the **"Add"** button. When adding sections, the preliminary result of the operation will be shown. The number of forming sections is not limited.

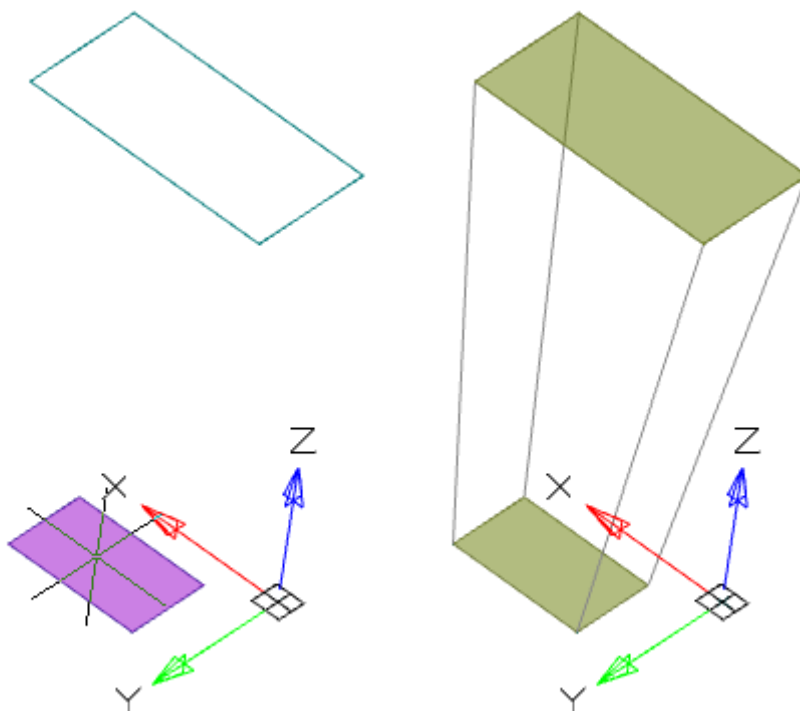

**Note:**

You can not add a new section without completing the geometry selection for the previous section.

**Note:**

If you have already selected a section from one sketch, and you want to select another section from another sketch, you must first deselect the

section you have already selected.

- Select the type of rails: Rails or Center line. For more information on rails, see below.
- If necessary, specify Rails or Center line. For more information on guides, see below.



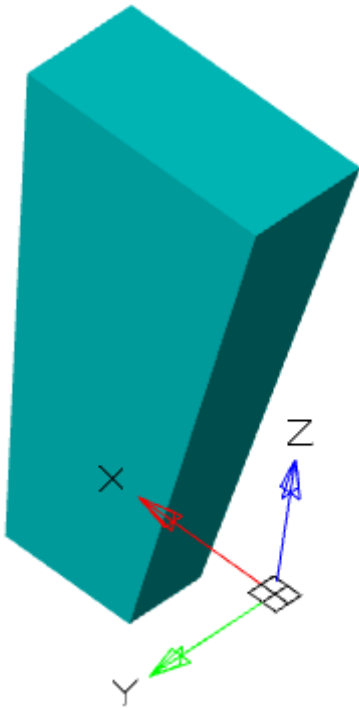

4. Press button **"OK"**. The operation will be performed.



### Dialog

Switch **"Associative"** - controls the settings parameter **"Associativity when creating new bodies"**. The enabled option allows you to build fixed bodies without the possibility of defixation.

A group of operation action selectors:

-  **"Join"** - creates a new object in the previously created body. The sketch must belong to the body.
-  **"Cut"** - creates a cutout. The sketch must belong to the body.
-  **"Intersect"** - creates an object to intersect the contours of the new sketch and the previously created body. The sketch must belong to the body.
-  **"New body"** - creates a new object. A new body appears in the tree of constructions. When a switch is selected, the previously selected sketch belonging to the body is detached from the body.

Ribbon Selection Panel:

-  Rails
-  Center line

List of sections. Contains a list of selected sections

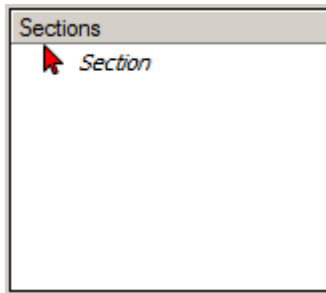

List of rails. Contains a list of selected curve rails.

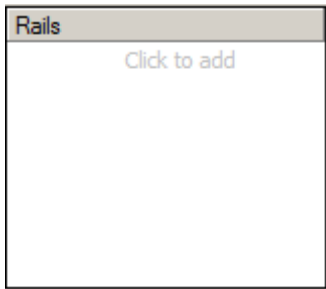

## ***Rails***

Rails determine the form of stretching across sections between sections.

Rails can be 2D or 3D curves or edges of an existing body. The number of rails is unlimited. Rails affect the whole form of stretching across sections, not just vertices.

Rails must pass strictly through each contour of drawing by sections. In this case, the start of the rail must be strictly on the contour of the first section, the end of the rail strictly on the contour of the last section.

Rail must not be interrupted.

It is possible to construct closed rails - in this case a closed body will be constructed.

The following guide curves are not allowed:

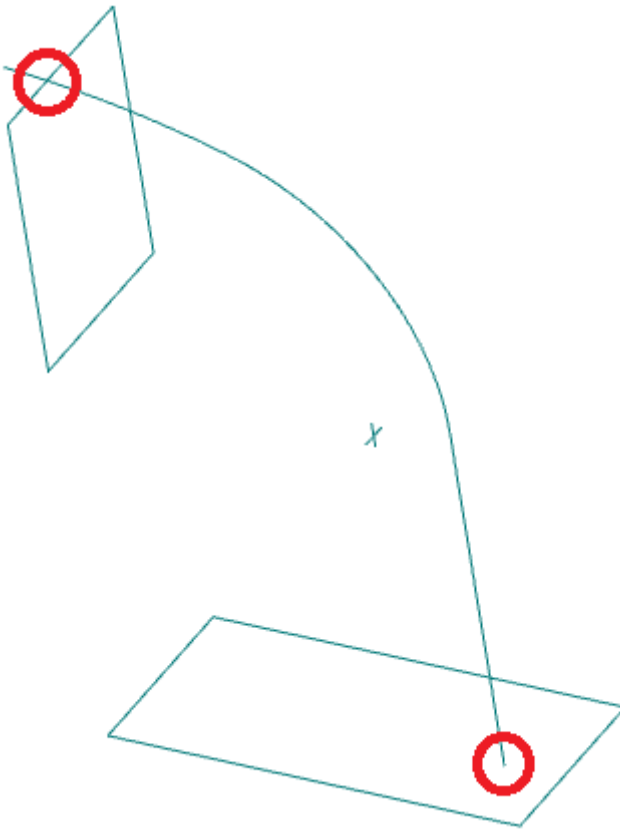

Example of using rails:

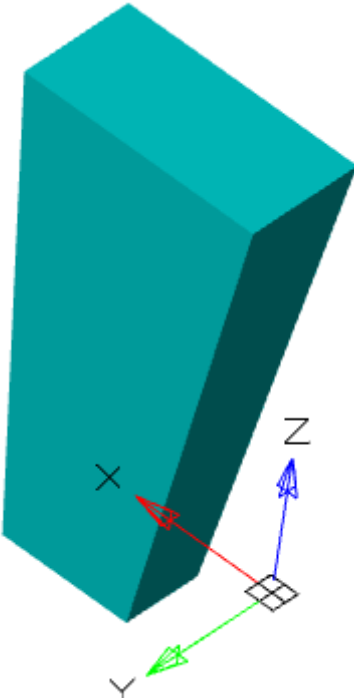
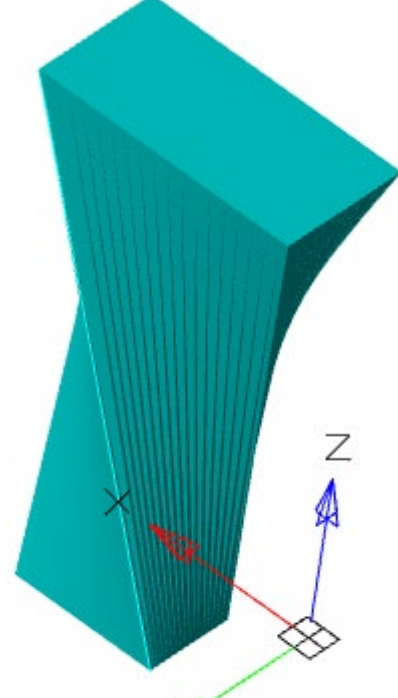
Without the use of rails	Using rails
	

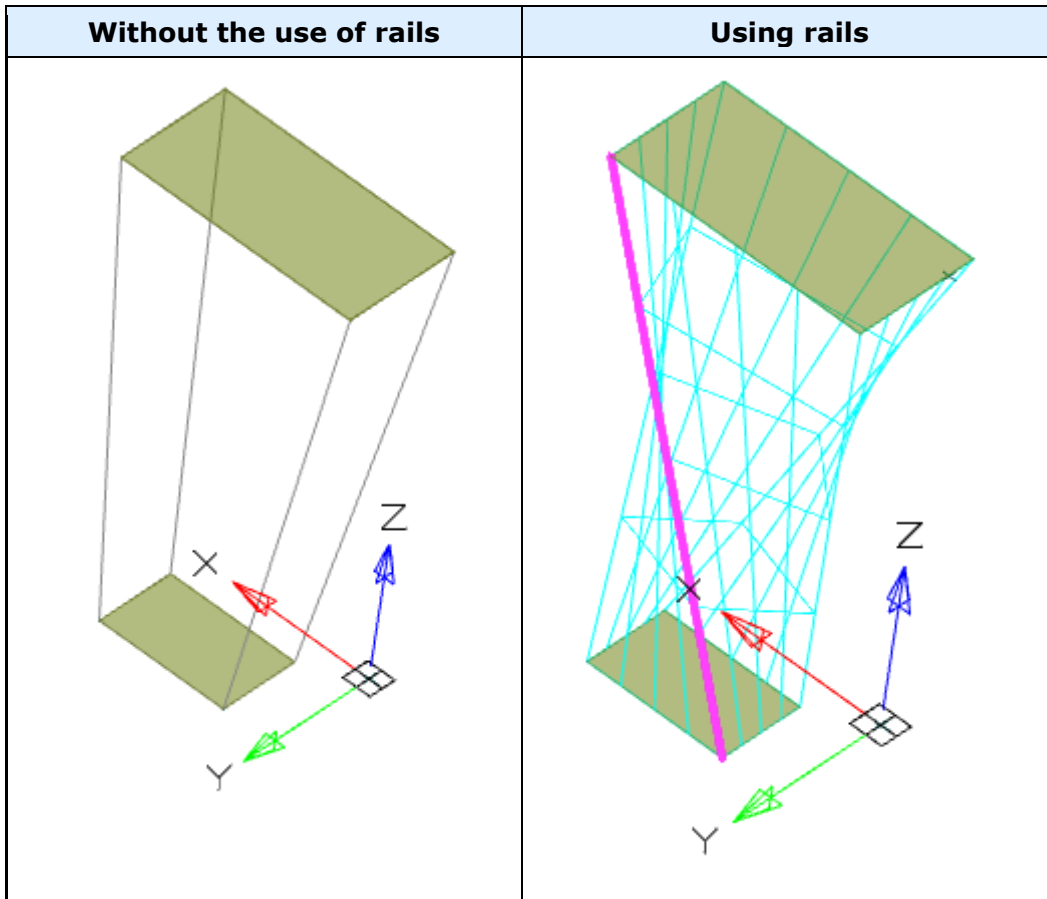

**Note:** Rail curves do not work when the **"Close"** option is selected.



### Center line

The centerline is the type of the railing curve. The center line must pass through each section. The center line can be only one.

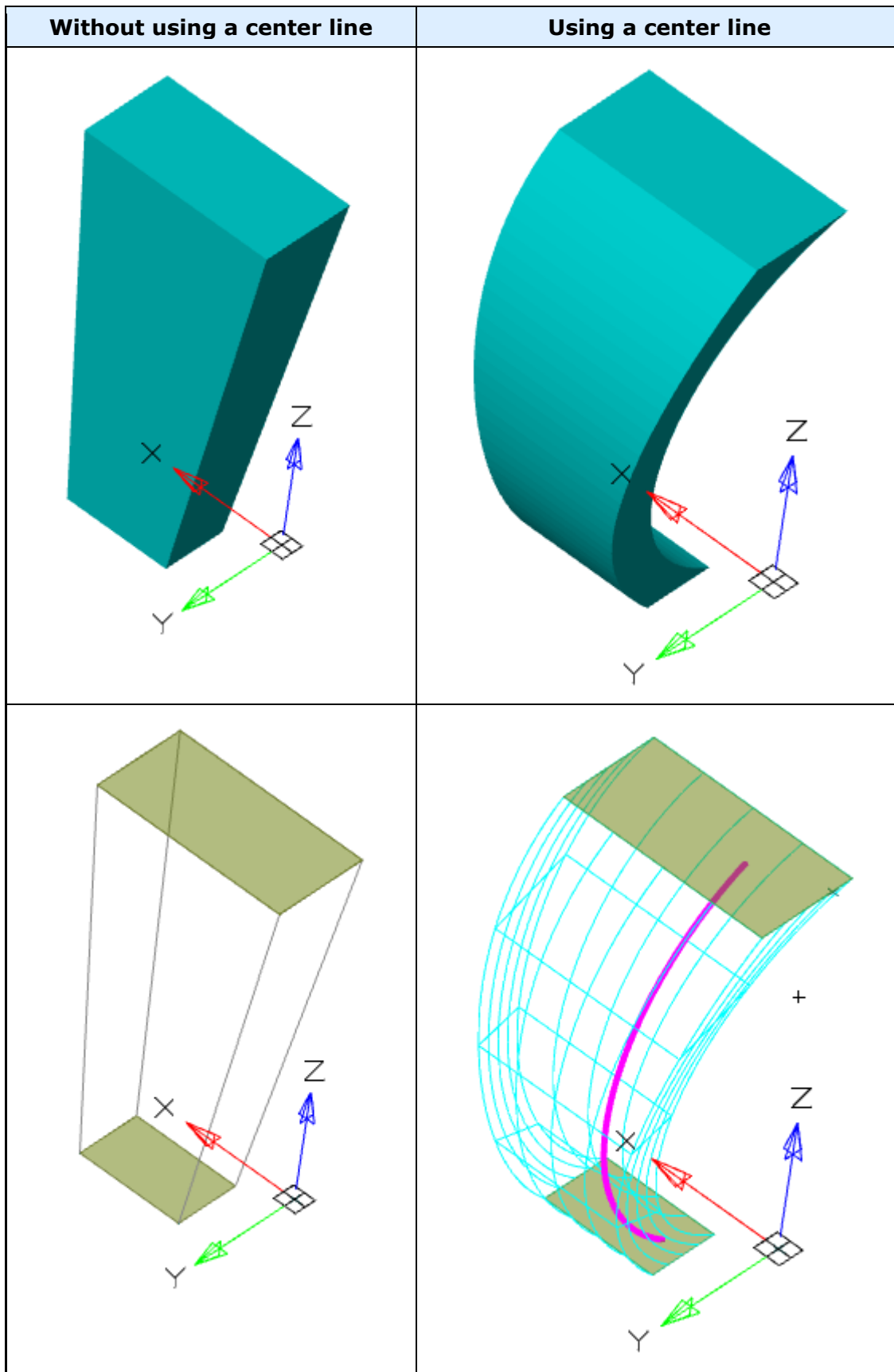
Without using a center line	Using a center line
-----------------------------	---------------------





### 3D History

 **"McLoftFeature"**. It is part of the body. Contains a list  **"Section"**.

The following shortcut menu commands are available for the object  **"McLoftFeature"**:





- **Edit** - calls for editing a 3D operation. To the right of the icon appears the editing symbol ⚡.
- **End edit** - completes the previously started editing.
- **Rename (F2)** - allows you to rename a 3D operation.
- **Delete (Del)** - removes the 3D operation and child objects from the tree and model space.
- **Suppress** - removes the 3D operation and child objects from the model space.
- **Unsuppress** - restores a 3D operation in model space.
- **ShowInDocument** - focuses and highlights the 3D operation in the center of the model space.
- **Rebuild** - rebuilds the object in model space.

3D operation  "**McLoftFeature**" there are child objects  "**Section**".

The following shortcut menu commands are available for the object  "**Section**":

- **Delete (Del)** - removes the section from the tree and model space.

## *Rebuild 3D model*







-  Main menu: **3D** -  **Rebuild 3D model**.
-  Ribbon: **3D Tools - Modeling** -  **Rebuild Model**.
-  Functional panel: **3D History** -  **Rebuild 3D model**.
-  Command line: **3DREBUILD**.

Tool for updating model parameters.

## *3D Solids*

The section "**3D Solids**" describes the creation of dwg-compatible 3D solids. The resulting objects can be edited using standard AutoCAD tools.

### *Box*

-  Main menu: **3D - Solid** -  **Box**.
-  Ribbon: **3D Tools - 3D Solids** -  **Box**.
-  Toolbar: **3D Solid** -  **Box**.
-  Command line: **3DBOX**.

The command create 3D solid - Box.

### *Procedure*

1. Call command  "**Box**".
2. Choose a point of reference (via context menu or command line): "**Corner**" (default) or "**Center**".

- Corner - the sides of the box are counted from the specified point.
  - Center - the sides are counted evenly from the center.
3. Specify the starting point in the selected way.
  4. Choose a base construction method: "**Corner**" (default), "**Cube**" or "**Length**".
    - Corner - a rectangle is constructed when specifying the second point.
    - Cube - the length, width and height will be the same and after specifying the point the box will be built.
    - Length - alternately indicate the length and width of the base.
  5. Build the base in the chosen way.

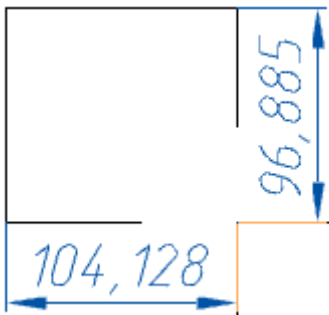

6. Select the method of setting the height: "**Height**" (default) or "**DistanceBy2Point**".
  - Height - the height of the box is set in the drawing or in the command line.
  - DistanceBy2Point - the height of the box is specified by specifying two points in the drawing.
7. Specify the height of the selected method.

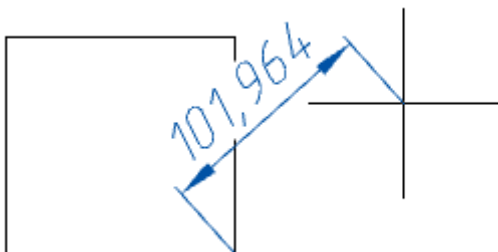

8. The box will be built.

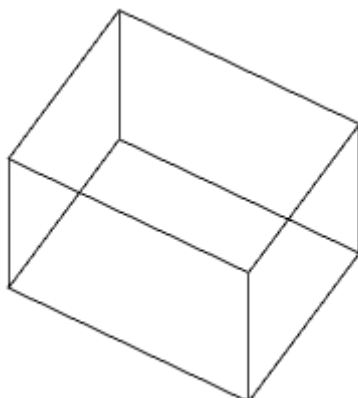



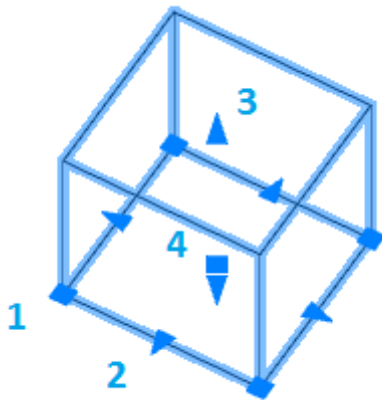

## Grips

1. Grips change the width and length of the base.
2. Grips change the width or length of the base.
3. Grips change the height of the box.
4. Grip moving object.



## 3D History

 **"3D solid"**. It is part of the  body.

The following context menu commands are available:

- **Rename (F2)** - allows you to rename an object.
- **Delete (Del)** - removes an object and child objects from the tree and model space.
- **ShowInDocument** - focuses and highlights the object in the center of the model space.
- **Rebuild** - rearranges the object in the model space.

## Cylinder



Main menu: **3D - Solid -  Cylinder.**



Ribbon: **3D Tools - 3D Solids -  Cylinder.**



Toolbar: **3D Solid -  Cylinder.**



Command line: **3DCYLINDER.**

The command create 3D solid - Cylinder.

## Procedure

1. Call command  **"Cylinder"**.
2. Choose a base construction method:
  - **Base center (default)** - the circle is built in the center and radius.

- **3Point** - the circle is built at three points.
- **RoundBaseBy2Point** - build a circle at two points.
- **Incircle round base** - a circle is constructed along two tangents.
- **Elliptical** - an ellipse is built along the center, half-line and radius.

3. Specify the necessary parameters depending on the chosen method of building the foundation. The foundation will be built.

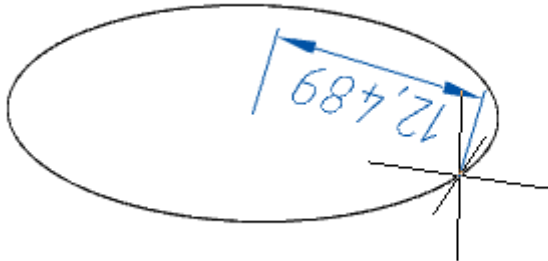

4. Choose a way to specify the height of the cylinder:

- **Height** - indicates the height in the drawing or on the command line.
- **DistanceBy2Point** - height is calculated by the specified two points in the drawing.
- **Axis endpoint** - height and direction are calculated at the specified point in the drawing, the first reference point is the center of the base.

5. Specify the required parameters depending on the selected method of specifying the height.

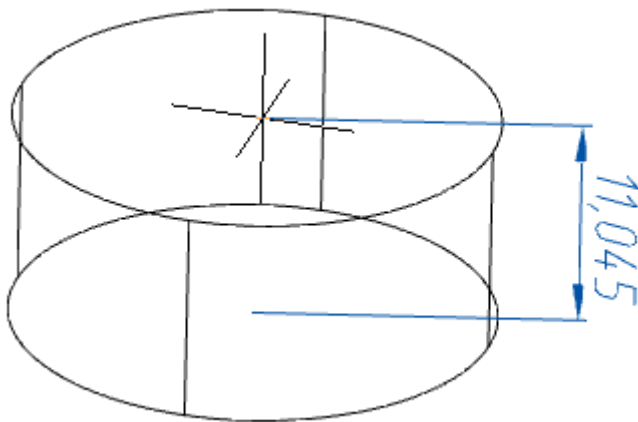

6. The cylinder will be built.

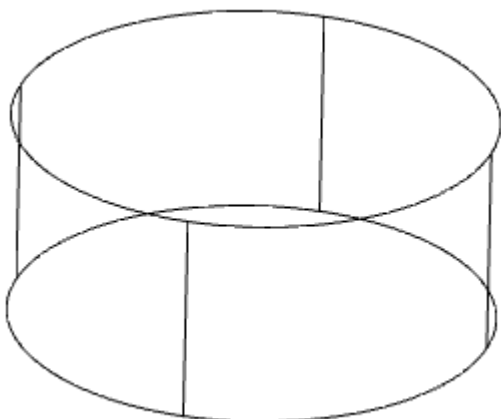

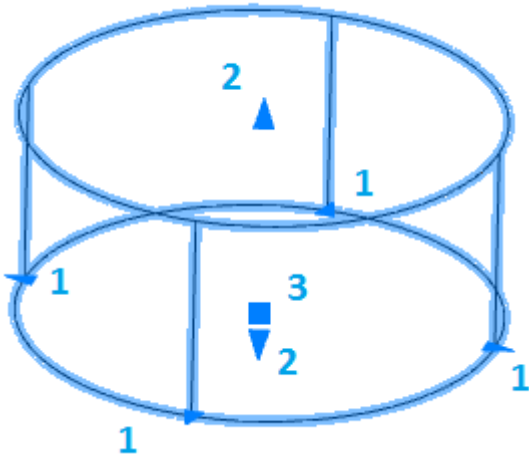

## Grips

1. Grips change the radius of the base.
2. Grips change the height of the cylinder.
3. Grip move.



## 3D History

 "3D solid". It is part of the  body.

The following context menu commands are available:

- **Rename (F2)** - allows you to rename an object.
- **Delete (Del)** - removes an object and child objects from the tree and model space.
- **ShowInDocument** - focuses and highlights the object in the center of the model space.
- **Rebuild** - rearranges the object in the model space.

## Cone



Main menu: **3D - Solid - Cone**.



Ribbon: **3D Tools - 3D Solids - Cone**.



Toolbar: **3D Solid - Cone**.



Command line: **3DCONE**.

The command create 3D solid - Cone.

## Procedure

1. Call command  "**Cone**".
2. Select the method for constructing the base:
  - **Base center (default)** - the circle is built in the center and radius.
  - **3Point** - the circle is built at three points.
  - **RoundBaseBy2Point** - build a circle at two points.

- **Incircle round base** - a circle is constructed along two tangents.
- **Elliptical** - an ellipse is built along the center, half-line and radius.

3. Specify the necessary parameters depending on the chosen method of building the foundation. The foundation will be built.

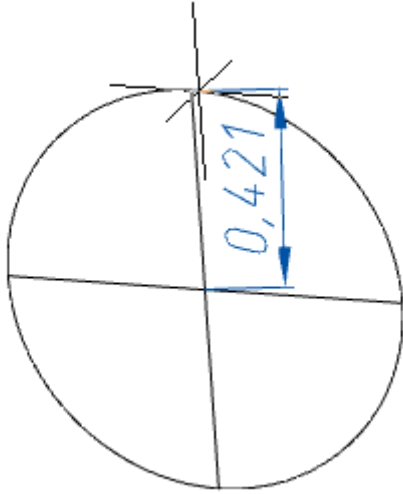

4. Choose a way to specify the height of the cone:

- **Height** - indicates the height in the drawing or on the command line.
- **DistanceBy2Point** - height is calculated by the specified two points in the drawing.
- **Axis endpoint** - height and direction are calculated at the specified point in the drawing, the first reference point is the center of the base.
- **Upper radius** - first the radius of the upper base is indicated, then the height is indicated.

5. Specify the required parameters depending on the selected method of specifying the height.

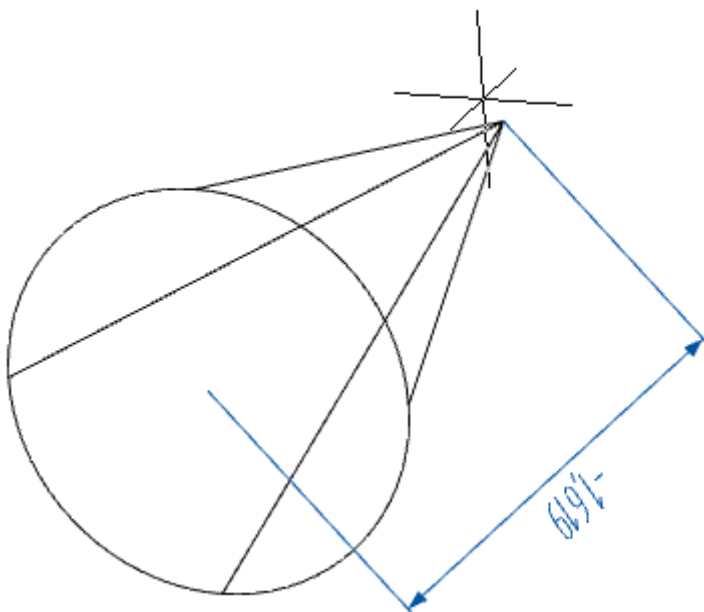

6. The cone will be built.

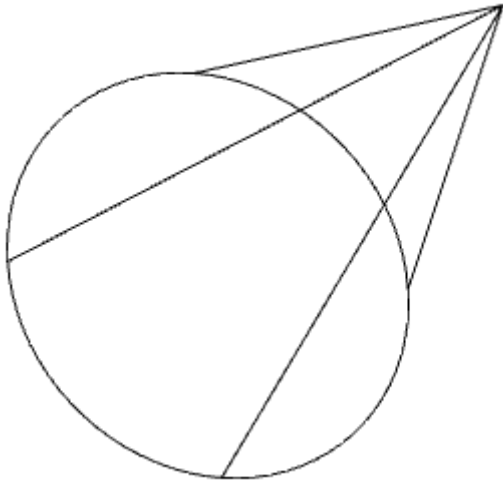

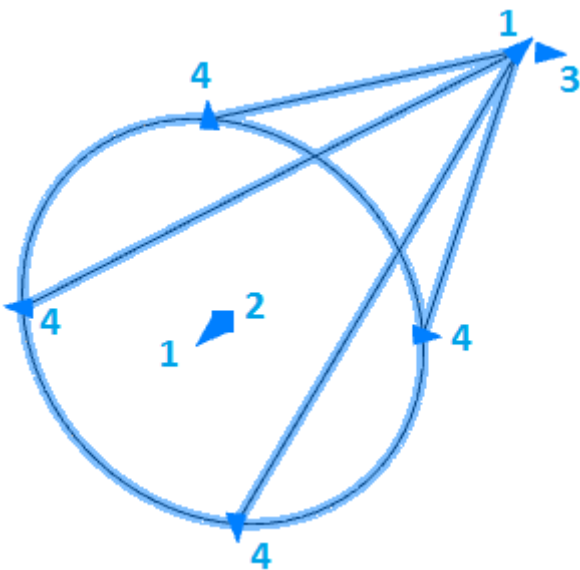

### Grips

1. Grips change the height of the cone.
2. Grip move.
3. Grip change the radius of the upper base.
4. Grips change the radius of the lower base.



### 3D History

 "3D solid". It is part of the  body.

The following context menu commands are available:

- **Rename (F2)** - allows you to rename an object.
- **Delete (Del)** - removes an object and child objects from the tree and model space.
- **ShowInDocument** - focuses and highlights the object in the center of the model space.
- **Rebuild** - rearranges the object in the model space.

## Sphere

 Main menu: **3D - Solid - Sphere**.

 Ribbon: **3D Tools - 3D Solids - Sphere**.

 Toolbar: **3D Solid - Sphere**.

 Command line: **3DSPHERE**.

The command create 3D solid - Sphere.

### Procedure

1. Call command **"Sphere"**.
2. Choose a way to build a sphere:
  - **Center (default)** - the circle is built in the center and radius.
  - **3Point** - the circle is built at three points.
  - **RoundBaseBy2Point** - build a circle at two points.
  - **Incircle round base** - a circle is constructed along two tangents.
3. Specify the necessary parameters depending on the selected construction method.

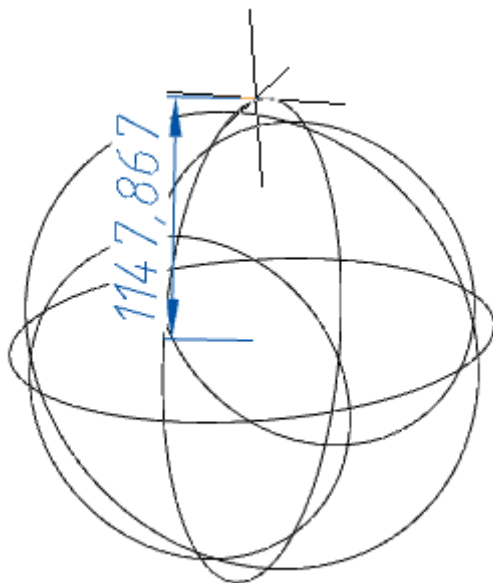

4. Sphere will be built.

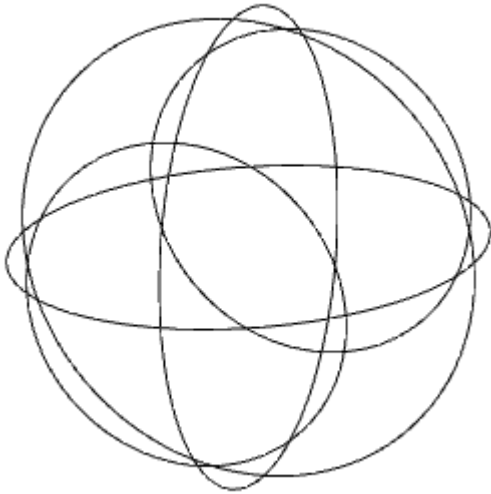

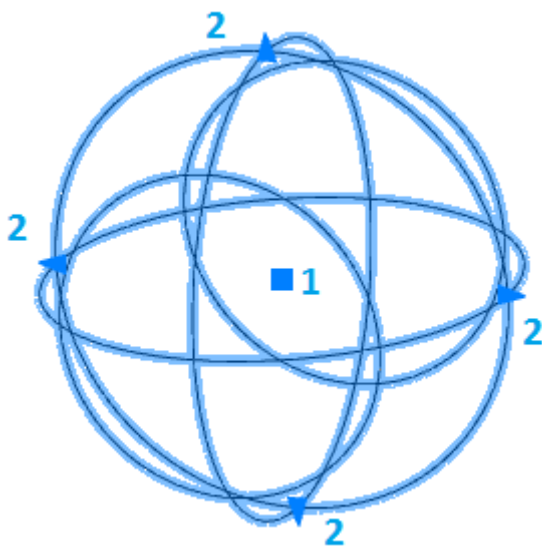

### Grips

1. Grip move.
2. Grips change radius.



### 3D History

 "3D solid". It is part of the  body.

The following context menu commands are available:

- **Rename (F2)** - allows you to rename an object.
- **Delete (Del)** - removes an object and child objects from the tree and model space.
- **ShowInDocument** - focuses and highlights the object in the center of the model space.
- **Rebuild** - rearranges the object in the model space.

### Pyramid



Main menu: **3D - Solid -  Pyramid.**

 Ribbon: **3D Tools - 3D Solids - Pyramid**.

 Toolbar: **3D Solid - Pyramid**.

 Command line: **3DPYRAMID**.

The command create 3D solid - Pyramid.

### Procedure

1. Call command  **"Pyramid"**.
2. Select the method for constructing the base:
  - **Base center (default)** - the base is built along the center and the radius of the inscribed or circumscribed circle.
  - **Edge** - the base is constructed by indicating two points. The length of the edge of the base of the pyramid is the distance between two points.
  - **Sides** - indication of the number of sides of the pyramid. After specifying the number of sides, the system again suggests choosing a construction method (p.2).
3. Specify the necessary parameters depending on the chosen method of building the foundation. The foundation will be built.

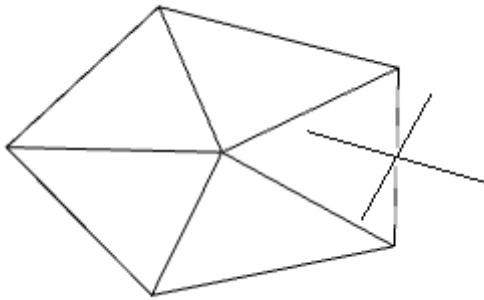

4. Choose a way to specify the height of the pyramid:
  - **Height** - indicates the height in the drawing or on the command line.
  - **DistanceBy2Point** - height is calculated by the specified two points in the drawing.
  - **Axis endpoint** - height and direction are calculated at the specified point in the drawing, the first reference point is the center of the base.
  - **Upper radius** - first the radius of the upper base is indicated, then the height is indicated.
5. Specify the required parameters depending on the selected method of specifying the height.



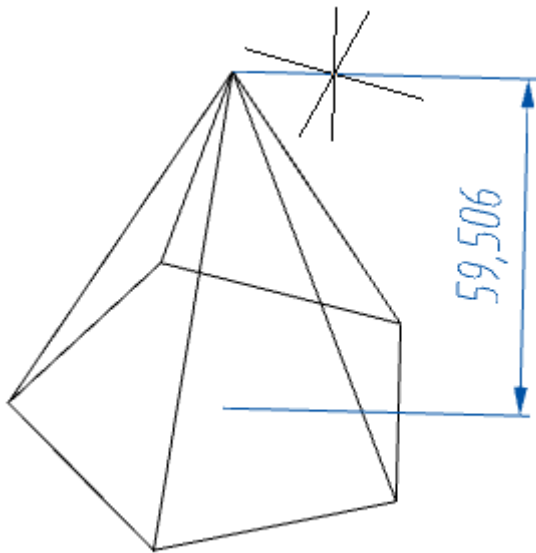

6. The pyramid will be built.

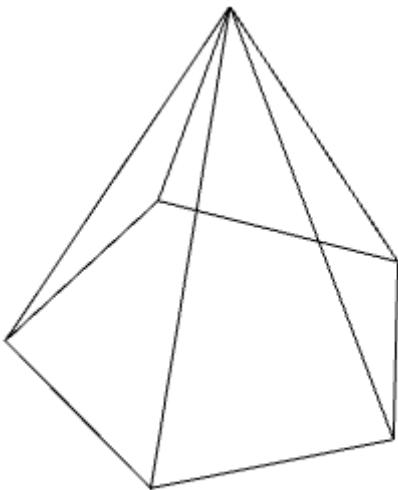

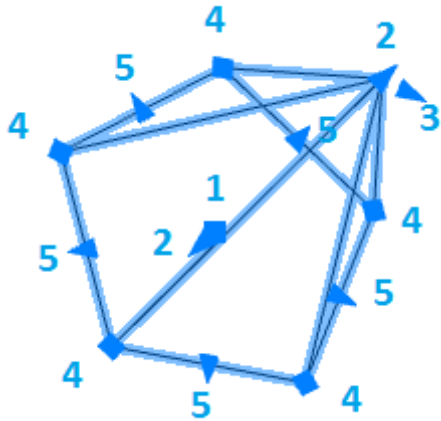

### **Grips**

1. Grips moving.
2. Grips change height.
3. Grips change the radius of the upper base.
4. Grips change the radius of the lower base.
5. Grips change the radius of the lower base.



### 3D History

 **"3D solid"**. It is part of the  body.

The following context menu commands are available:

- **Rename (F2)** - allows you to rename an object.
- **Delete (Del)** - removes an object and child objects from the tree and model space.
- **ShowInDocument** - focuses and highlights the object in the center of the model space.
- **Rebuild** - rearranges the object in the model space.

## Wedge



Main menu: **3D - Solid -  Wedge**.



Ribbon: **3D Tools - 3D Solids -  Wedge**.



Toolbar: **3D Solid -  Wedge**.



Command line: **3DWEDGE**.

The command create 3D solid - Wedge.

### Procedure

1. Call command  **"Wedge"**.
2. Select a point of reference (via the context menu or on the command line): **"Corner"** (default) or **"Center"**.
  - Corner - the sides of the wedge are counted from the specified point.
  - Center - the sides are counted evenly from the center.
3. Specify the point of reference in the chosen way.
4. Select the method for constructing the base: **"Corner"** (default), **"Cube"** or **"Length"**.
  - Corner - a rectangle is constructed when specifying the second point.
  - Cube - the length, width and height will be the same and after specifying the point a wedge will be built.
  - Length - alternately indicate the length and width of the base.

5. Build the base in the chosen way.

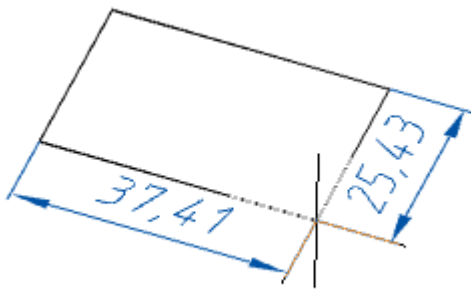

6. Select the method of setting the height: **"Height"** (default) or **"DistanceBy2Point"**.

- Height - the value of the height of the wedge is set in the drawing or in the command line.
- DistanceBy2Point - the value of the height of the wedge is set by specifying two points in the drawing.

7. Specify the height of the selected method.

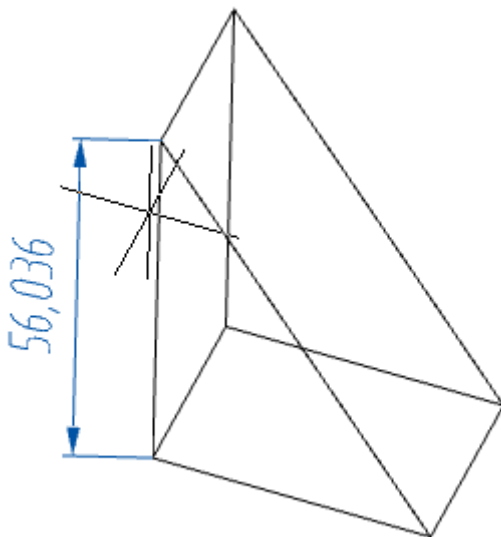

8. Wedge will be built.

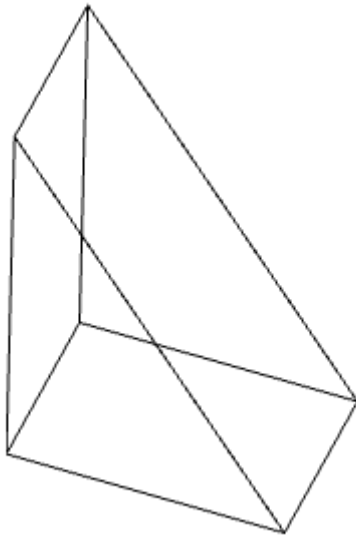

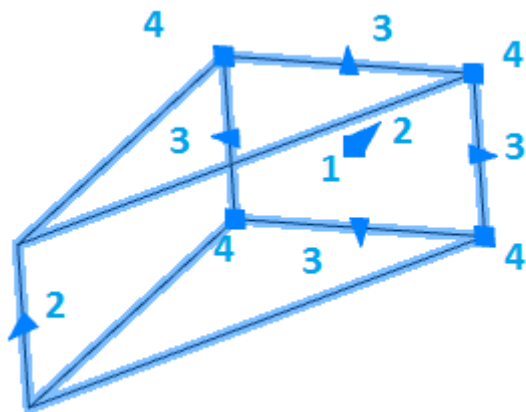

### Grips

1. Grip move.
2. Grips wedge height changes.
3. Grips change the length or width of the base of the wedge.
4. Grips change the length and width of the base of the wedge.



### 3D History

 "3D solid". It is part of the  body.

The following context menu commands are available:

- **Rename (F2)** - allows you to rename an object.
- **Delete (Del)** - removes an object and child objects from the tree and model space.
- **ShowInDocument** - focuses and highlights the object in the center of the model space.
- **Rebuild** - rearranges the object in the model space.

### Torus



Main menu: **3D - Solid** -  **Torus**.

 Ribbon: **3D Tools - 3D Solids - Torus**.

 Toolbar: **3D Solid - Torus**.

 Command line: **3DTORUS**.

The command create 3D solid - Torus.

### Procedure

1. Call command **"Torus"**.
2. Select the method for constructing the axial radius:
  - **Center (default)** - the circle is built in the center and radius.
  - **3Point** - the circle is built at three points.
  - **RoundBaseBy2Point** - build a circle at two points.
  - **Incircle round base** - a circle is constructed along two tangents.
3. Specify the necessary parameters depending on the chosen method of constructing the axial radius.

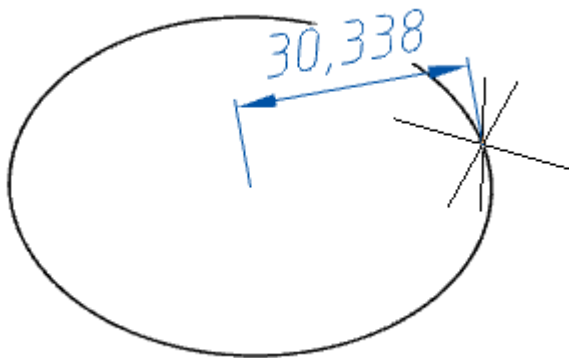

4. Choose a way to specify the cavity radius:
  - **Minor radius** - indicates the radius in the drawing or in the command line.
  - **DistanceBy2Point** - the radius is calculated from the indicated two points in the drawing.
5. Specify the required parameters depending on the selected method of specifying the cavity radius.

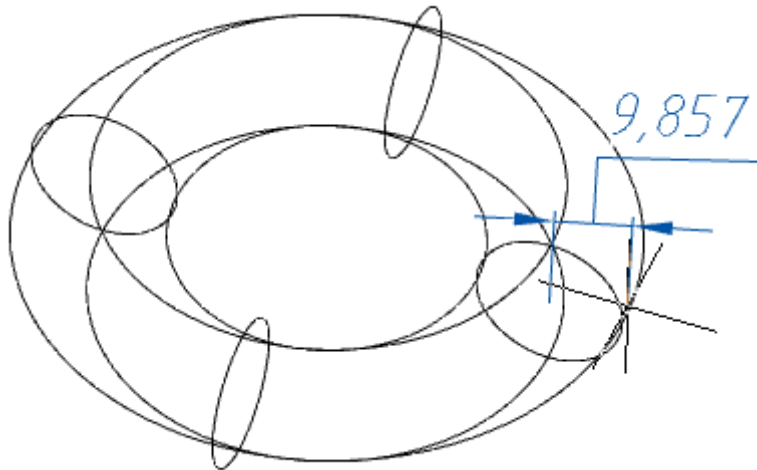

6. Torus will be built.

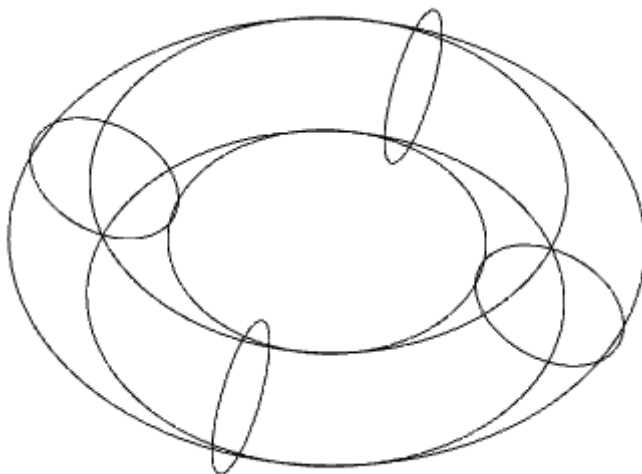

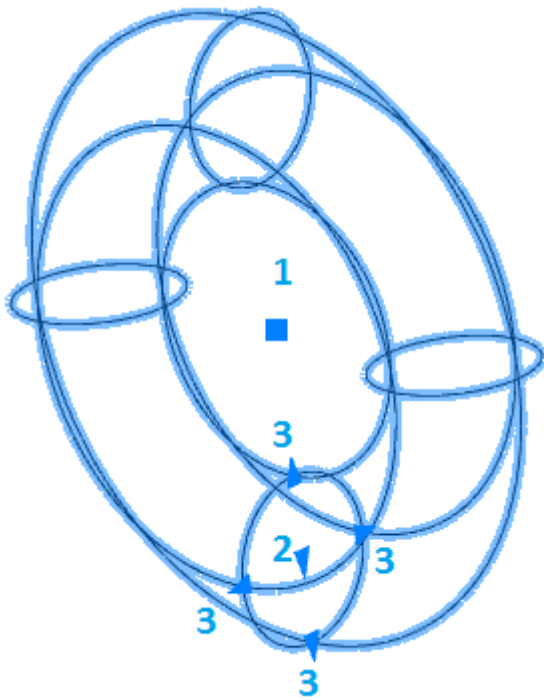

### ***Grips***

1. Grip move.
2. Grip changes in axial radius.
3. Grips change the radius of the cavity.



### 3D History

 "3D solid". It is part of the  body.

The following context menu commands are available:

- **Rename (F2)** - allows you to rename an object.
- **Delete (Del)** - removes an object and child objects from the tree and model space.
- **ShowInDocument** - focuses and highlights the object in the center of the model space.
- **Rebuild** - rearranges the object in the model space.

### Polysolid



Main menu: **3D - Solid -  Polysolid.**



Ribbon: **3D Tools - 3D Solids -  Polysolid.**



Toolbar: **3D Solid -  Polysolid.**



Command line: **3DPOLYSOLID.**

The command create 3D solid - Polysolid.

### Procedure

1. Call command  "Polysolid".
2. Configure polysolid parameters using the commands:
  - **Height** - specifies the height of the polysolid.
  - **Width** - specifies the width of the polysolid.
  - **Alignment** - alignment is chosen when building: Left, Center or Right.

3. Select the build method:

- **Polyline** (default) - polysolid will be constructed in the same way as polyline.
- **Object** - the polysolid will be constructed by specifying the geometric object in the drawing, except for the spline and ellipse.

4. Build polysolid selected method of construction.

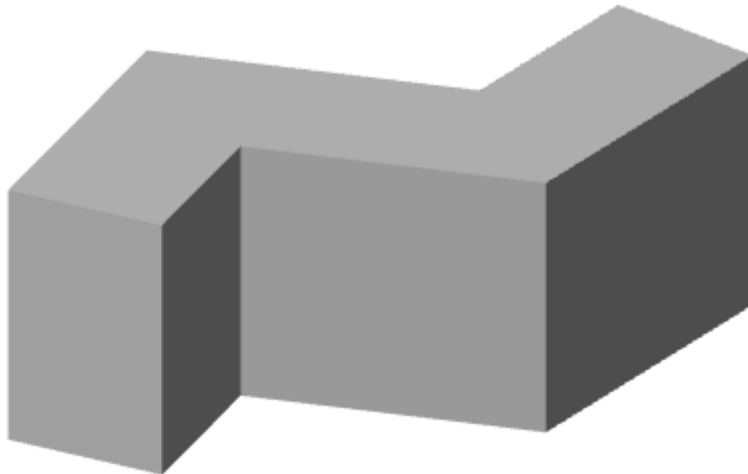

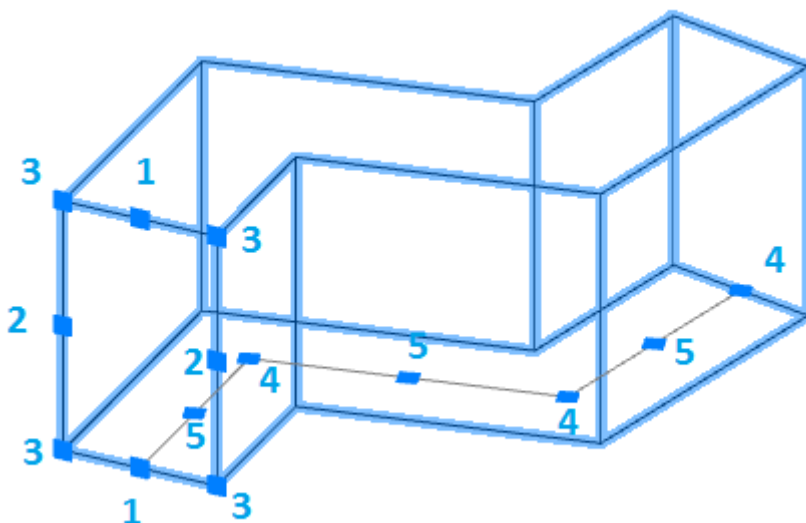

### *Grips*

1. Grips height changes
2. Grips change the width.
3. Grips change the width and height.
4. Grips move end points of segments.
5. Grips moving segments.



### *3D History*

 "3D solid". It is part of the  body.



The following context menu commands are available:

- **Rename (F2)** - allows you to rename an object.
- **Delete (Del)** - removes an object and child objects from the tree and model space.
- **ShowInDocument** - focuses and highlights the object in the center of the model space.
- **Rebuild** - rearranges the object in the model space.

## *Interfere 3D solids*



Main menu: **3D - Solid - Interfere 3D solids.**



Ribbon: **3D Tools - 3D Solids - Interfere 3D solids.**



Toolbar: **3D Solid - Interfere 3D solid.**



Command line: **3DINTERFERE.**

### *Procedure*

1. Call command **Interfere 3D solids**.
2. Select the first set of bodies. To complete the set selection, press **Enter**.

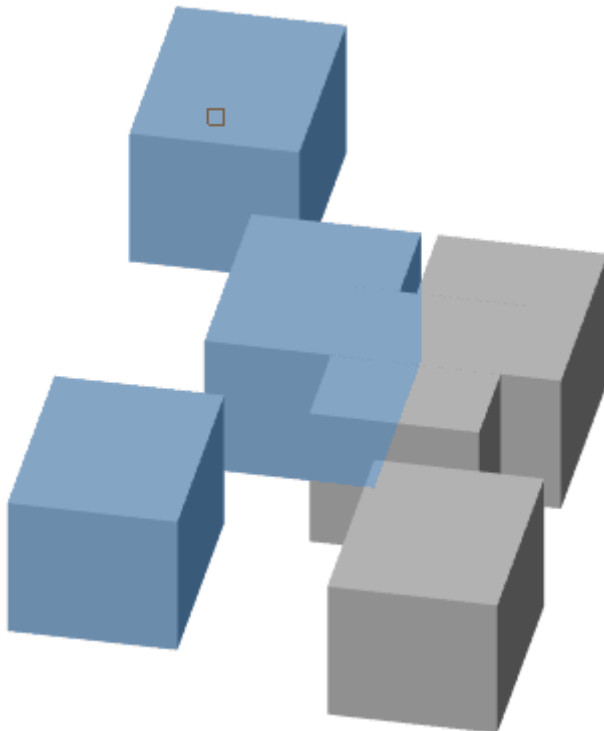

2. Select the second set of objects or select the command **check first set**. When you select the second set, the overlap between sets, when selecting **check first set**, overlaps within the set are analyzed.

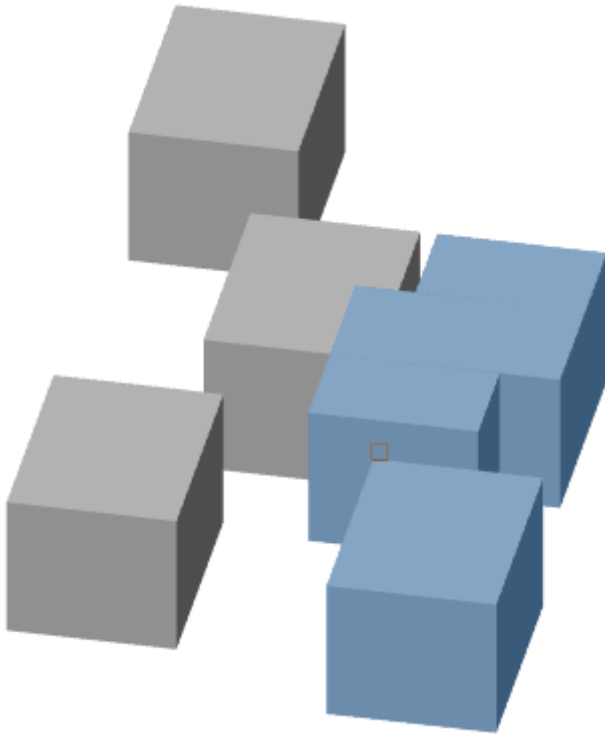

3. If overlaps exist, a dialog opens **"Interference checking"**, otherwise - the command will end..

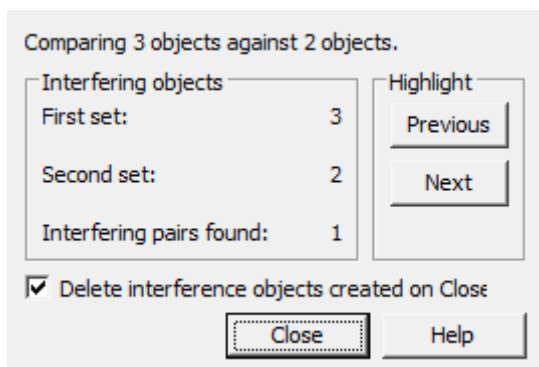

Interaction objects will be created and highlighted in the drawing.

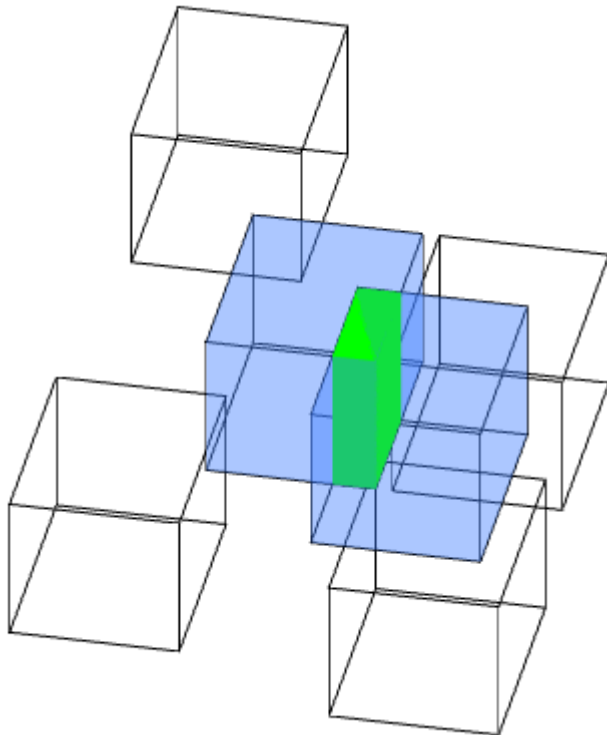

5. Perform floor analysis. In group **"Interfering objects"** shows the number of objects from the two sets and the number of pairs found. In group **"Highlight"** using the buttons **"Previous"** and **"Next"** highlight the interaction objects in the drawing. Switch **"Delete interference objects on Close"** deletes created interaction objects after closing the dialog **"Interference checking"**.

6. Close dialog **"Interference checking"** on button **"Close"**.

## Extrude



Main menu: **3D - 3D solid edit - Extrude**.



Ribbon: **3D Tools - 3D Solids - Extrude**.



Toolbar: **3D Edit - Extrude**.



Command line: **EXTRUDE**.

## Procedure

1. Call command **Extrude**.

2. Select, if necessary, the type of object being created. Call the command **Mode** from the context menu or from the command line and select type: **"Solid"** or **"Surface"**.

Solid	Surface
-------	---------

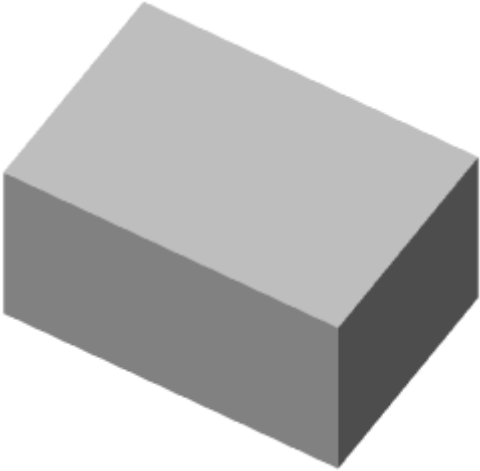
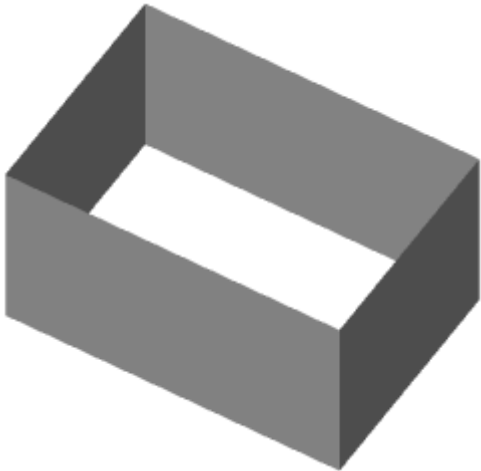
Solid	Surface
	

3. Select graphic primitives involved in extrusion. To complete the selection, press the key **"Enter"**.

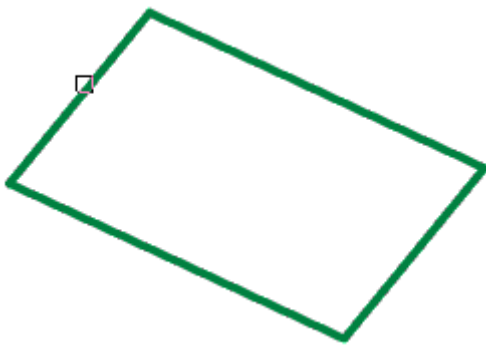

4. Indicate, if necessary, **"Taper angle"**. Call the **"Taper angle"** command from the context menu or from the command line and enter the angle value. The command can be repeated several times.

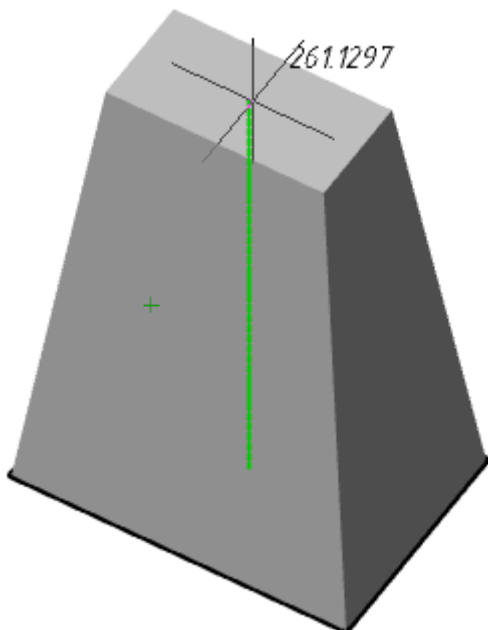

5. Select the method for setting the extrusion depth:

- **Height (default)** - extrusion depth is set by the value in the command line or by the indication in the drawing.

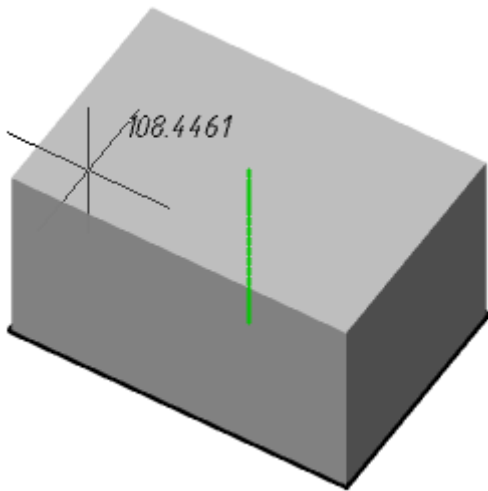

- **Direction** - extrusion depth is set by two points in the drawing. The direction should not be coplanar or tangent to the plane of the object.

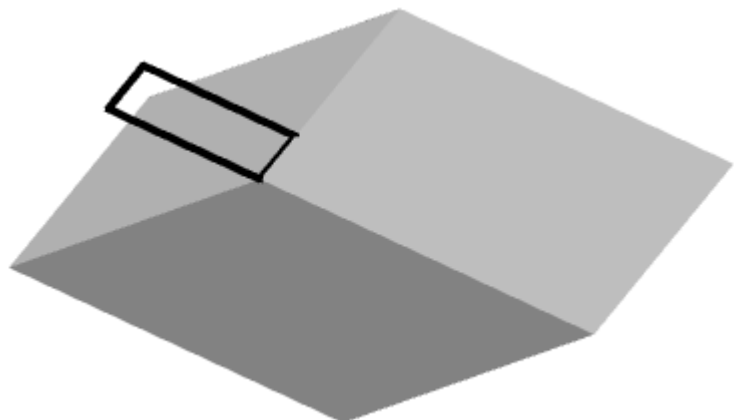
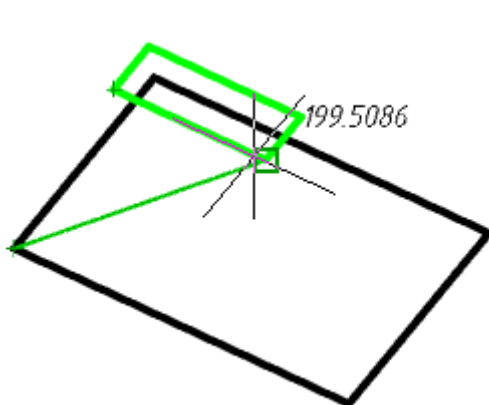

- **Path** - extrusion depth is set by specifying the trajectory. The path must not be coplanar or tangent to the plane of the object.

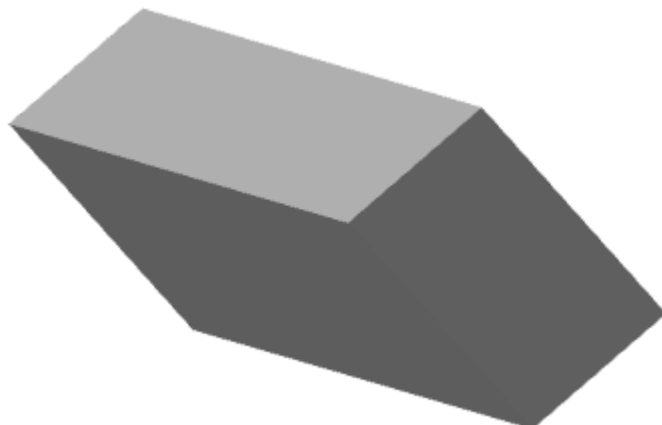
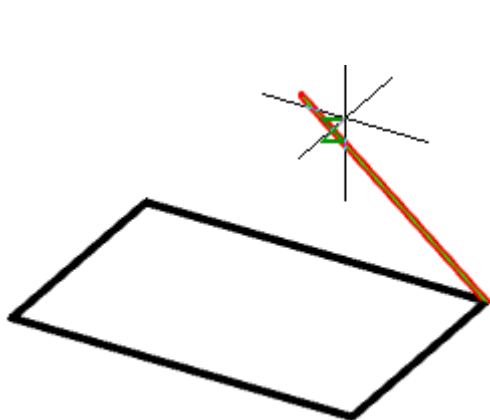

6. Set the extrusion depth using the selected method. The body or surface will be built.



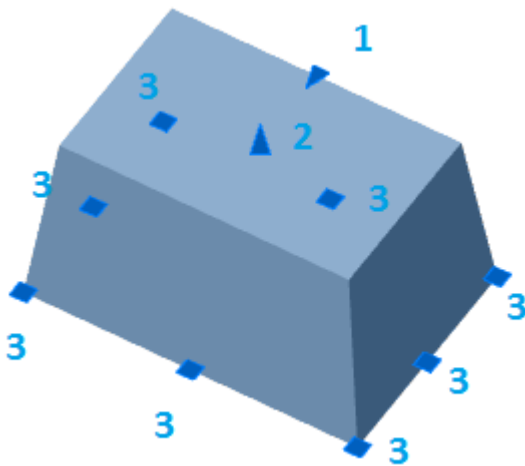

### Grips

1. Grip taper - allows you to change the angle of taper.
2. Grip Depth - allows you to change the depth of extrusion.
3. Grips section - handles change the shape of the section.



### Revolve

 Main menu: **3D - 3D solid edit -  Revolve.**

 Ribbon: **3D Tools - 3D Solids -  Revolve.**

 Toolbar: **3D Edit -  Revolve.**

 Command line: **REVOLVE.**

### Procedure

1. Call command  **"Revolve"**.
2. Select, if necessary, the type of object being created. Call the command **"Mode"** from the context menu or from the command line and select type: **"Solid"** or **"Surface"**.

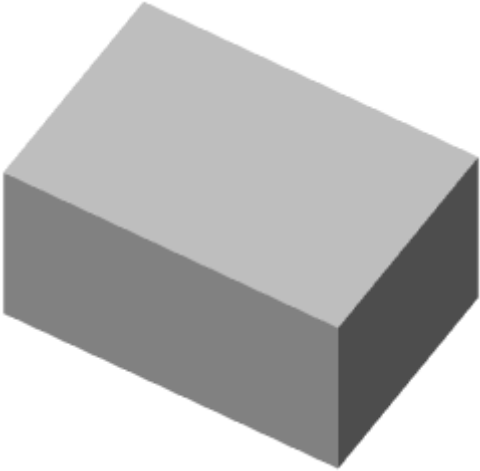
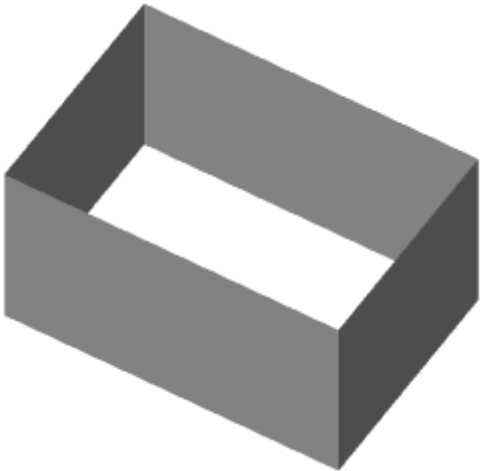
Solid	Surface
	

3. Select rotating graphic primitives. To complete the selection, press the **"Enter"** key.

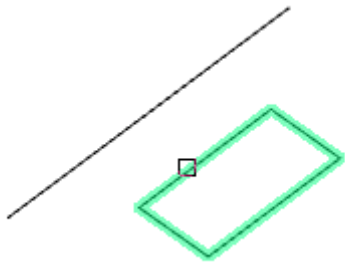

4. Select rotation axis:

**2Points (default)** - the axis is selected by sequential indication of two points.

**Object** - the axis is selected by specifying the object.

**X/Y/Z** - UCS axes are selected as the axis.

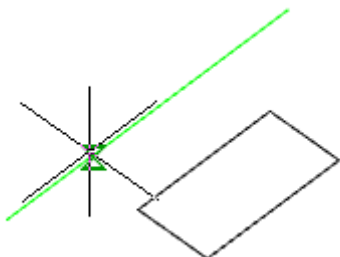

5. Change, if necessary, the direction of rotation. Call the command **"Reverse"** from the context menu or from the command line. Repeat the command the required number of times.

6. Change, if necessary, the initial angle of reference. Call the command **"Specify start angle"** from the context menu or from the command line. Enter the value of the starting angle. The value may be negative. Repeat the command the required number of times.

7. Specify the angle of rotation. The body or surface will be built.

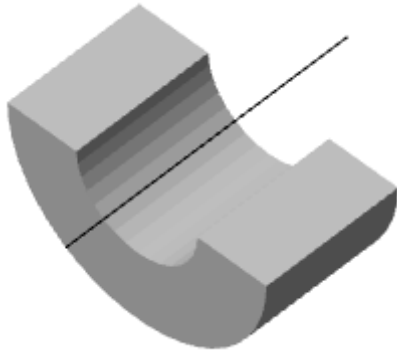

### Grips

1. Grip rotation angle - allows you to change the rotation angle.
2. Grip axis movement - allows you to change the position of the axis.
3. Grips section - handles change the shape of the section.

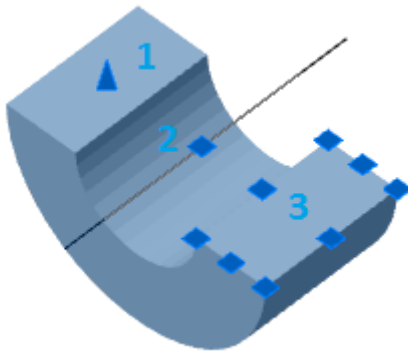

### Loft

 Main menu: **3D - 3D solid edit -  Loft.**

 Ribbon: **3D Tools - 3D Solids -  Loft.**

 Toolbar: **3D Edit -  Loft.**

 Command line: **LOFT.**

### Procedure

1. Call command  **"Loft"**.
2. Select, if necessary, the type of object being created. Call the command **"Mode"** from the context menu or from the command line and select type: **"Solid"** or **"Surface"**.

<b>Solid</b>	<b>Surface</b>
--------------	----------------

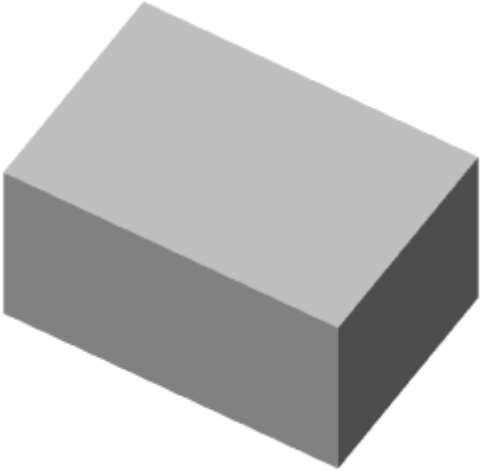
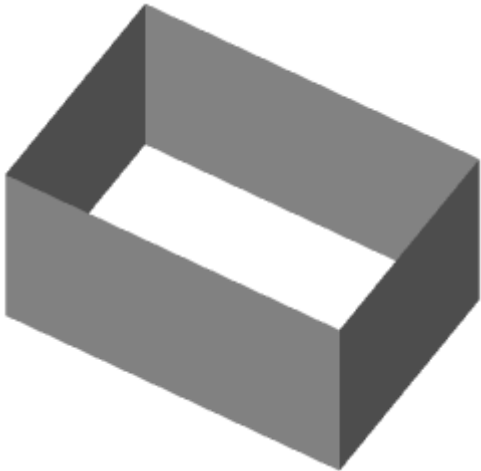

Solid	Surface
	

3. Specify the sections in sequence in the required order. To complete, press the **"Enter"** key. All sections must be either closed or open.

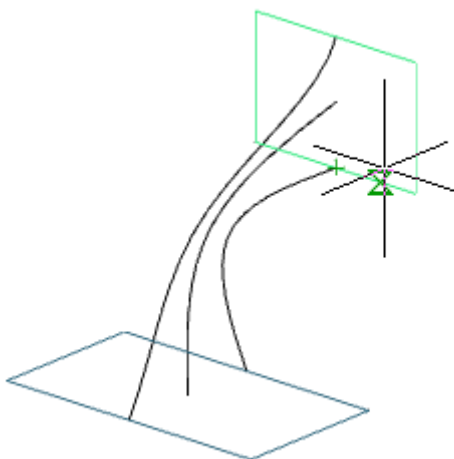

4. Set additional build parameters:

**Cross-section only (default)** - only sections are taken into account when calculating stretching.

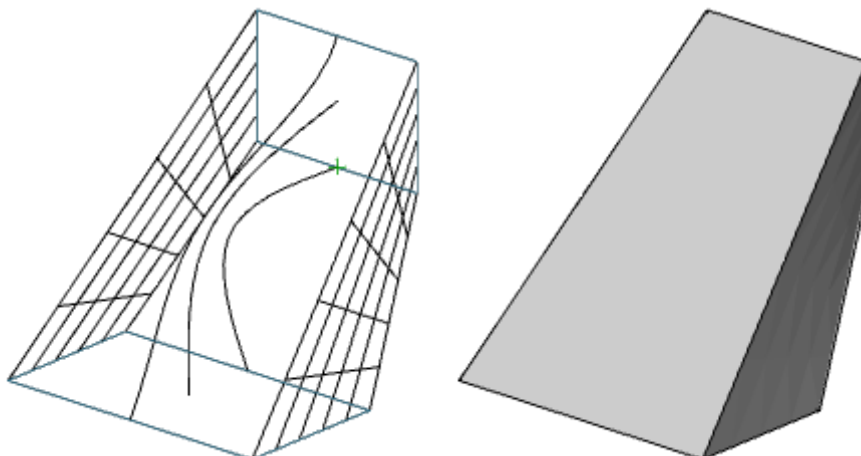

**Guides** - when calculating the stretching, sections and additional guides are taken into account.

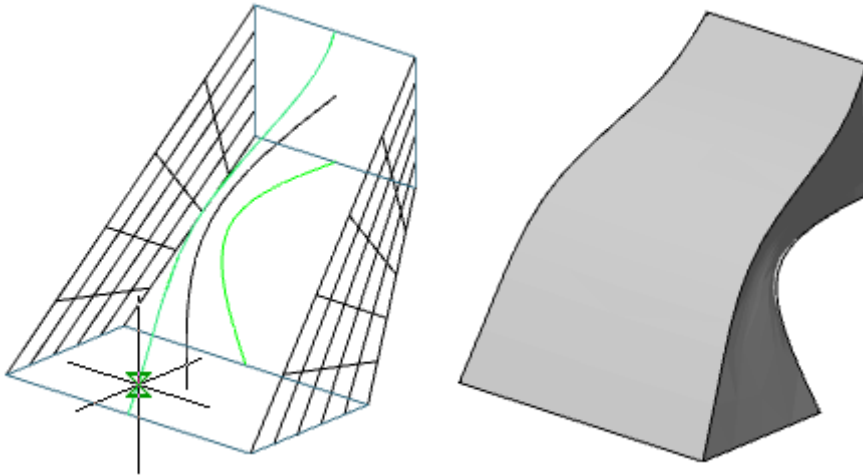

**Path** - when calculating the extrusion takes into account the section and the trajectory

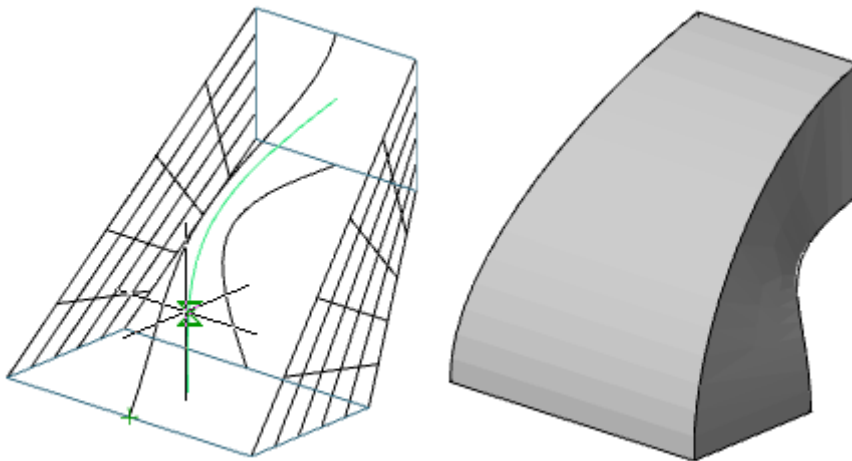

5. Confirm the parameters on the **"Enter"** key. Loft will be built.

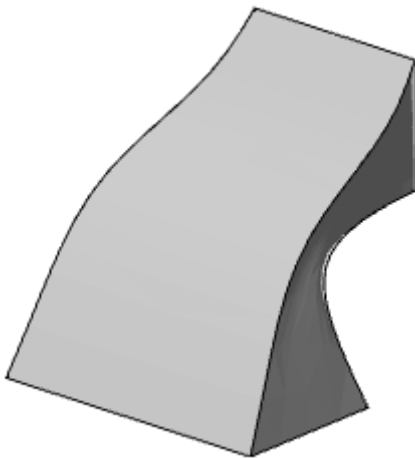

### **Grips**

Section Grips - allow you to change the shape of sections.

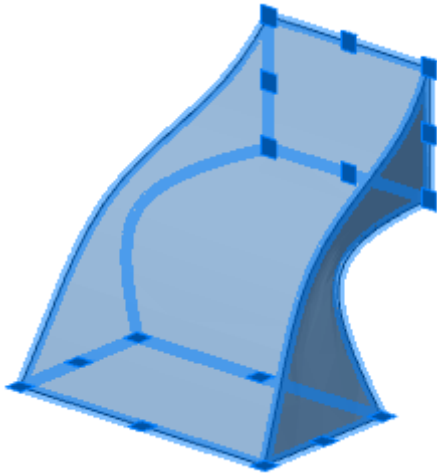

## Sweep

 Main menu: **3D - 3D solid edit - Sweep**.



 Ribbon: **3D Tools - 3D Solids - Sweep**.

 Toolbar: **3D Edit - Sweep**.

 Command line: **SWEEP**.

### Procedure

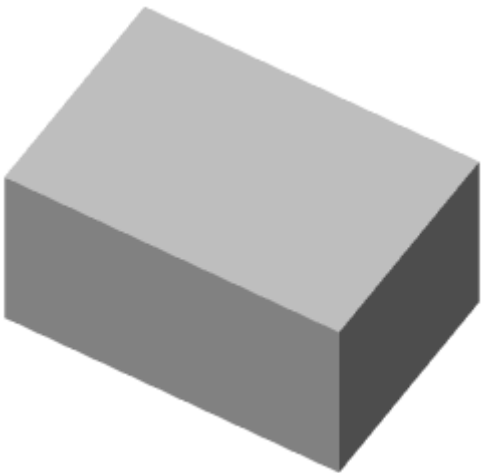
1. Call command  "Sweep".
2. Select, if necessary, the type of object being created. Call the command "**Mode**" from the context menu or from the command line and select type: "**Solid**" or "**Surface**".

Solid	Surface
	

3. Select graphic primitives involved in the shift. To complete the selection, press the "**Enter**" key.

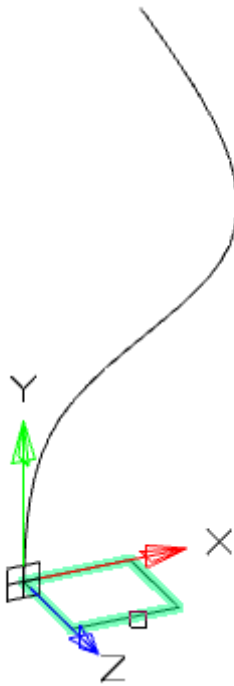

4. If necessary, specify the alignment. Alignment can be perpendicular to the path or parallel to the section. Call the command "**Alignment**" from the context menu or from the command line and select the alignment option.
5. If necessary, specify a base point. The trajectory and section will be combined at the base point. Call the command "**Base point**" from the context menu or from the command line and specify the point on the section.
6. If necessary, specify the scale. Call the "**Scale**" command from the context menu or from the command line and specify the scale value.
7. If necessary, specify the twist angle. Call the "**Twist**" command from the context menu or from the command line and specify the angle value.
8. Select the trajectory.

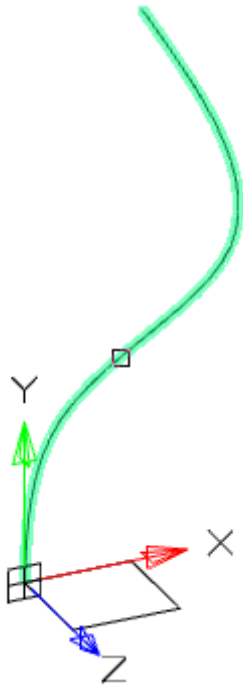

9. Sweep will be built.

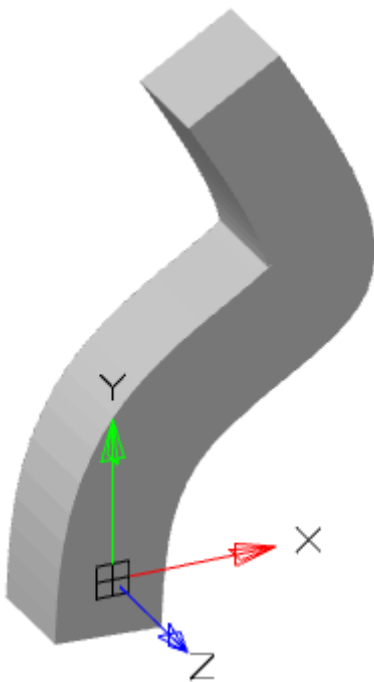

### **Grips**

1. Grip move - allows you to move the 3D-body.

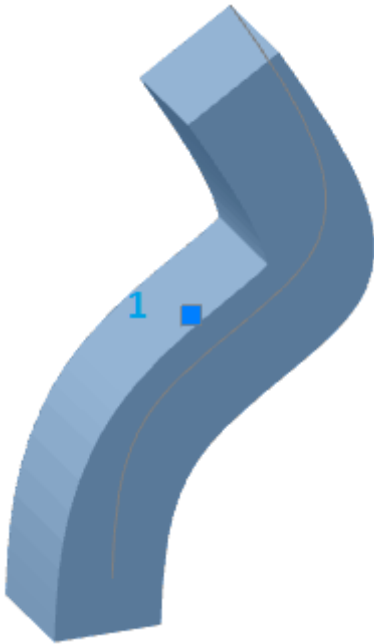

## *Slice*

 Main menu: **3D - 3D solid edit -  Slice.**

 Ribbon: **3D Tools - 3D Solids -  Slice.**

 Toolbar: **3D Edit -  Slice.**

 Command line: **SLICE.**

## *Procedure*

1. Call command  "**Slice**".
2. Select the 3D body to be cut. To complete the selection, press the **"Enter"** key.

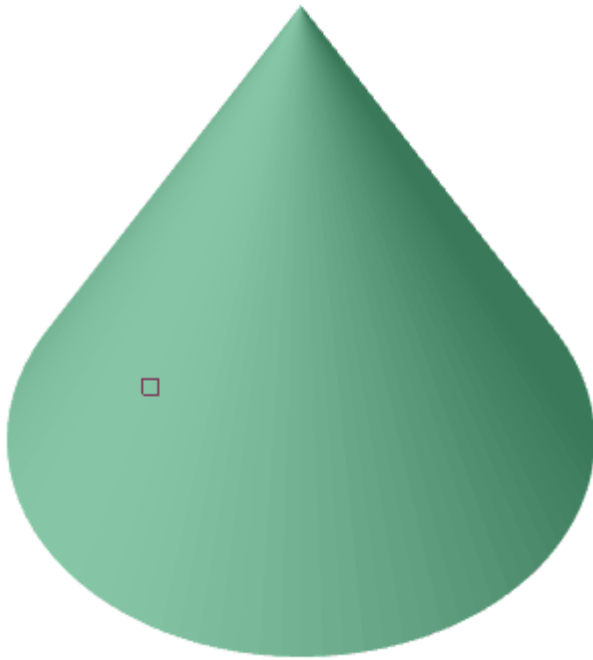

3. Select the method of defining the section plane:

**2Points (default)** - a cutting plane is constructed at two points perpendicular to the XY plane.

**3Points** - the cutting plane is defined by three points.

**Planar object** - A flat object is selected as the cutting plane.

4. Build a cutting plane in the chosen way.

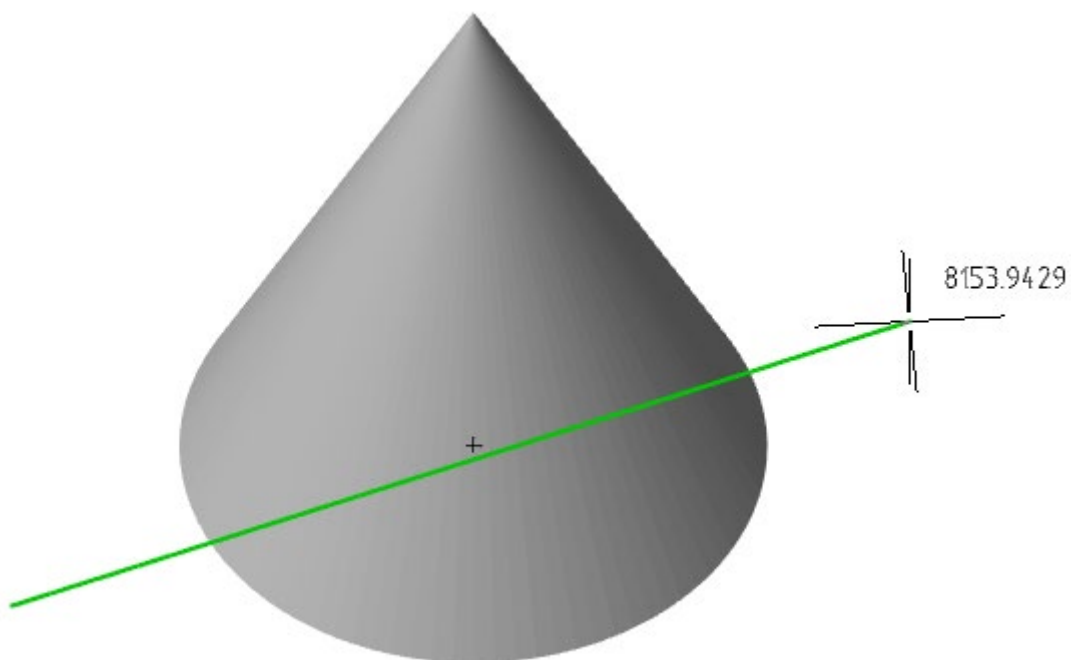

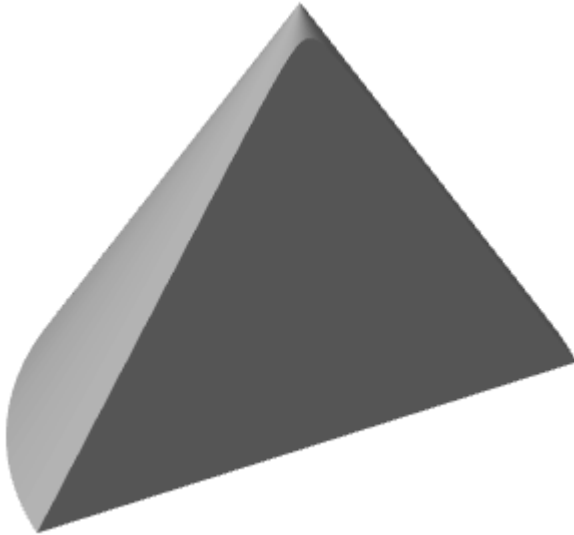

5. Click the side you want to leave, or "**Both**".

6. The selected 3D bodies will be cut.



## *Section*

 Main menu: **3D - 3D solid edit -  Section.**

 Ribbon: **3D Tools - 3D Solids -  Section.**

 Toolbar: **3D Edit -  Section.**

 Command line: **SECTION.**

The command creates a region object representing a 2D cross section of 3D objects, including 3D solids, surfaces, and meshes.

## *Procedure*

1. Prepare objects.



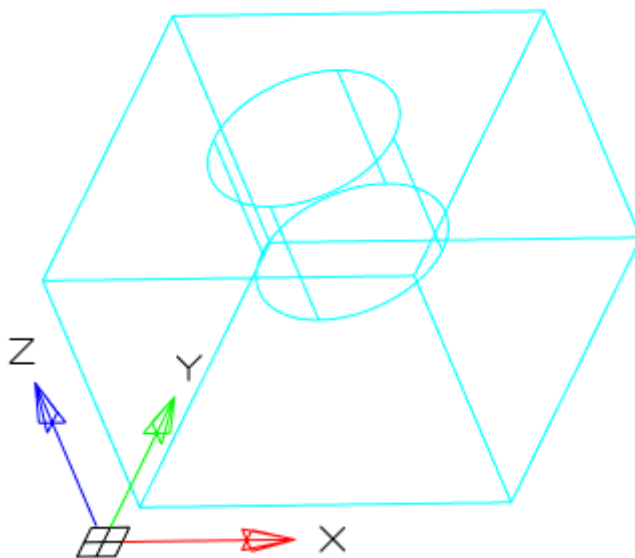
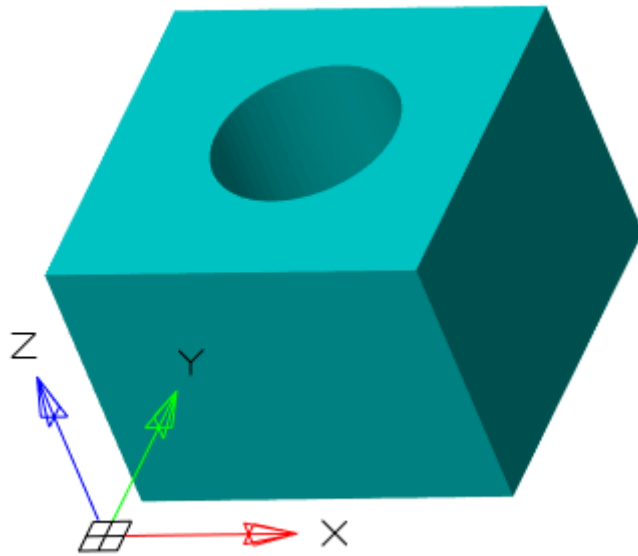

2. Call command  **"Section"**.

3. Select one or more 3D objects. Selecting multiple objects results in a separate area for each object.

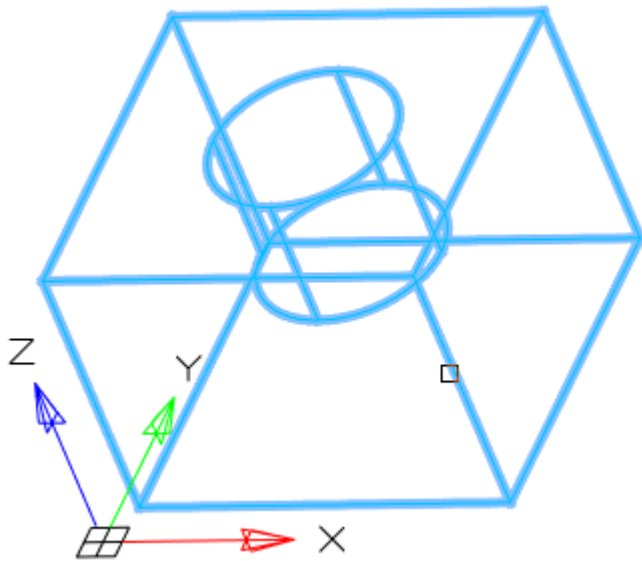

4. Choose a method for specifying the plane:

- 3points (default) - Specifies a cutting plane by three points.

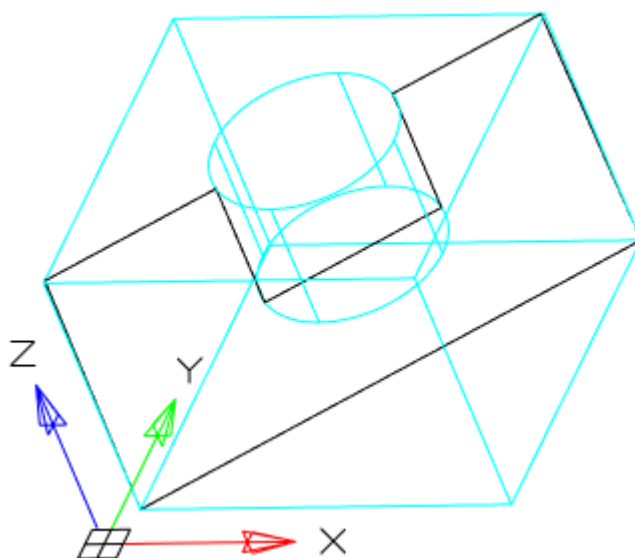
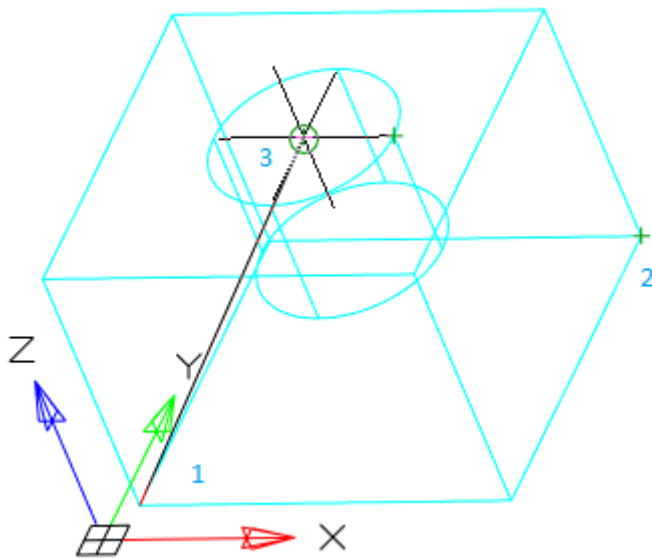

- Object - Aligns a cutting plane with a segment, circle, ellipse, circular or elliptical arc, 2D spline, or 2D polyline segment.

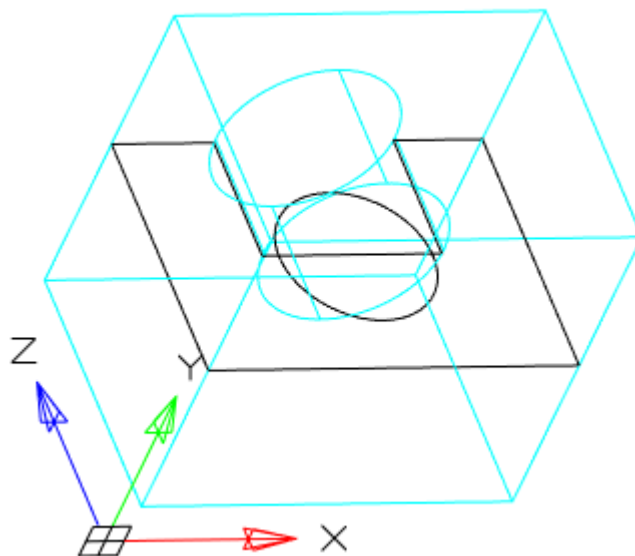
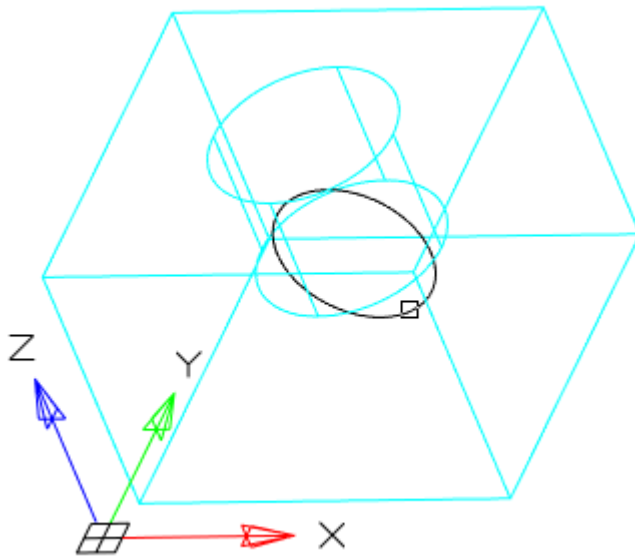

- Zaxis - Defines a section plane by specifying one point on that section plane and a second point on the z-axis or normal on that plane.
  1. Point on the cutting plane. Sets the first point on the plane.
  2. A point on the Z-axis (normal) on the plane. Sets the point that defines the axis perpendicular to the plane.

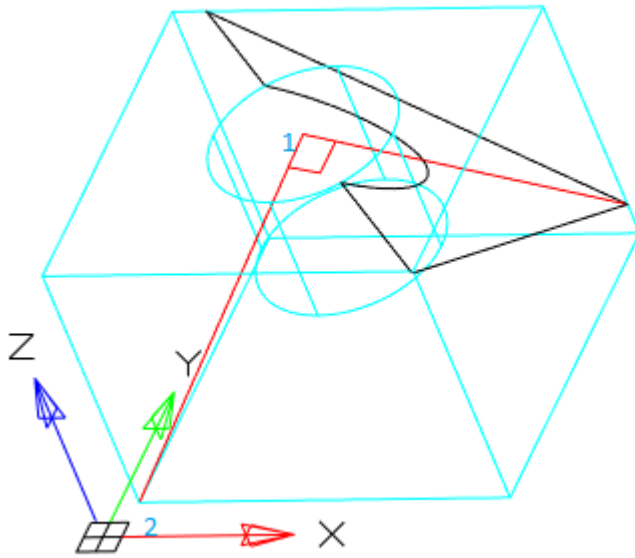

- View - Aligns the section plane with respect to the current view. After choosing the method, you should specify the point through which the plane will pass.

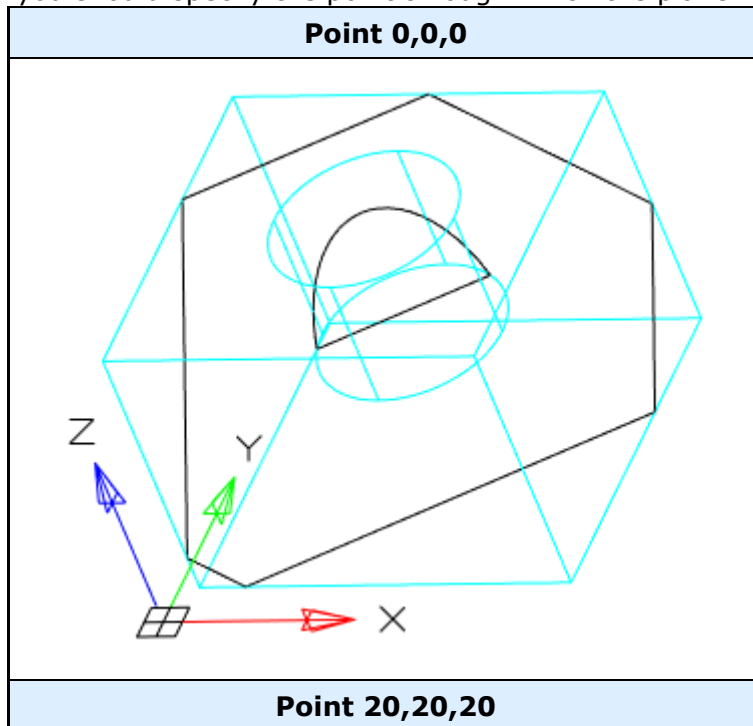

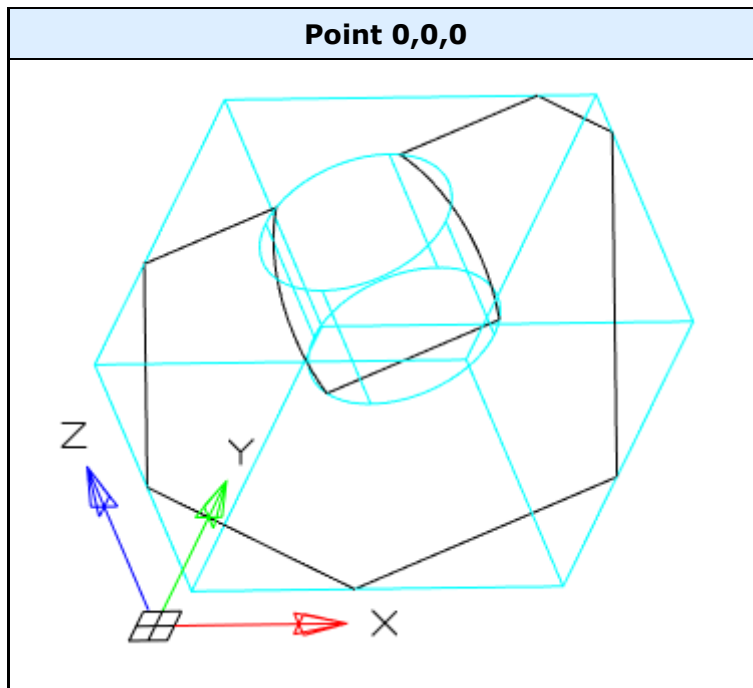

- XY - Aligns the section plane with the XY plane of the current UCS. After choosing the method, you should specify the point through which the plane will pass.

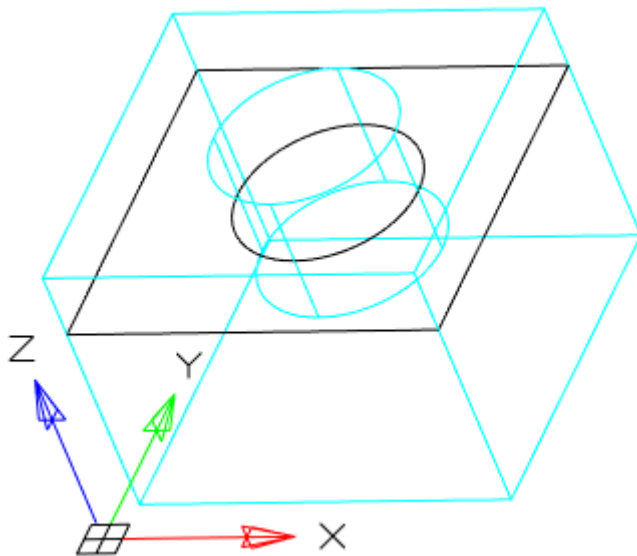

- YZ - Aligns the section plane with the YZ plane of the current UCS. After choosing the method, you should specify the point through which the plane will pass.

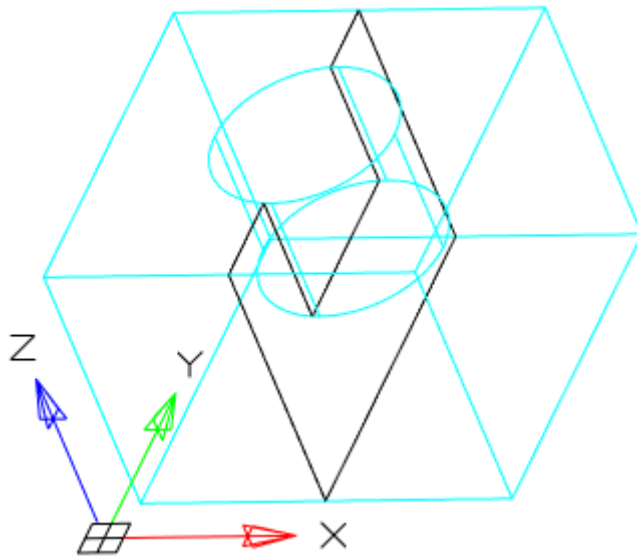

- ZX - Aligns the section plane with the ZX plane of the current UCS. After choosing the method, you should specify the point through which the plane will pass.

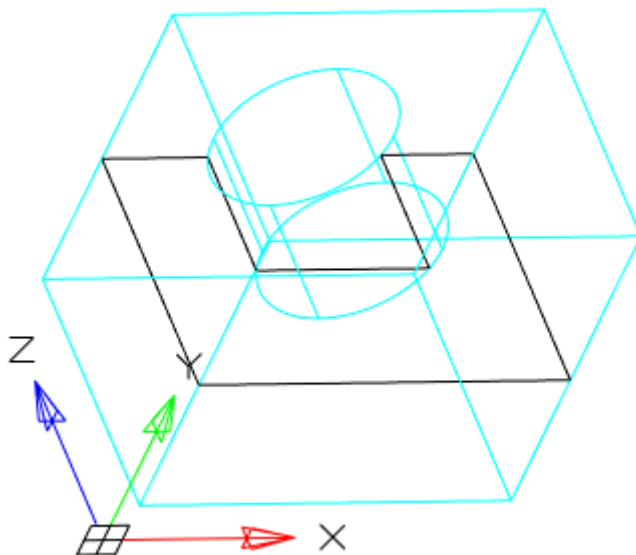

5. In accordance with the selected method, specify the section plane.

6. The area will be built.

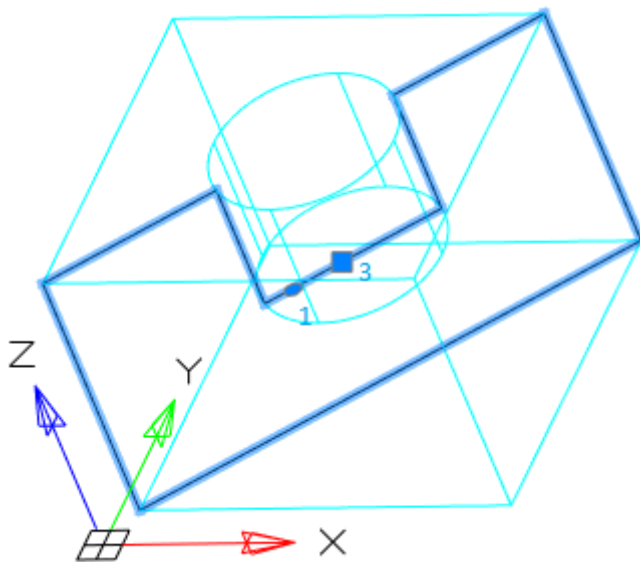
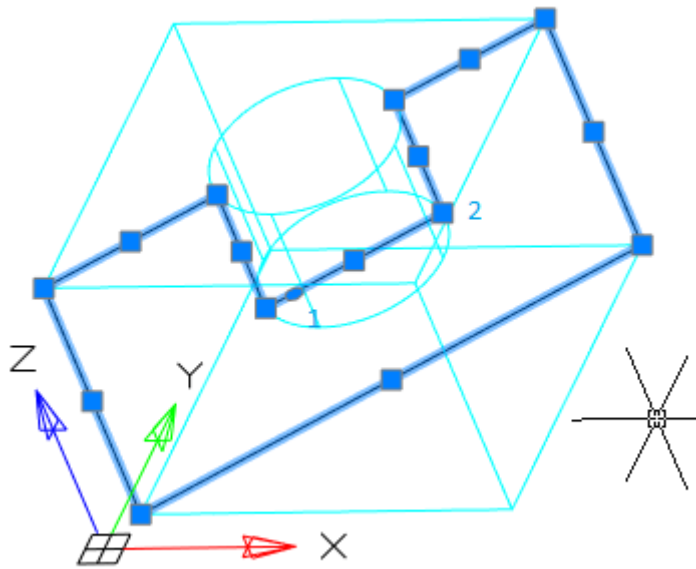

### **Grips**

1. Mode change grip: move mode, area change mode.
2. Nodal grips.
3. Movement grip.



## Thicken

 Main menu: **3D - 3D solid edit -  Thicken.**

 Ribbon: **3D Tools - 3D Solids -  Thicken.**

 Toolbar: **3D Edit -  Thicken.**

 Command line: **THICKEN.**

The team works with "**Surface**" objects. The command sets the surface thickness.

## Procedure

1. Call command  "**Thicken**".

2. Select surfaces to set the thickness. To complete the selection, press the "**Enter**" key.

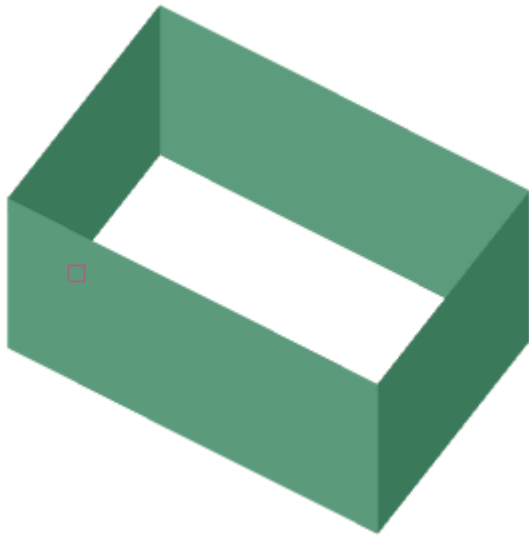

3. Enter a new thickness. The value may be negative.

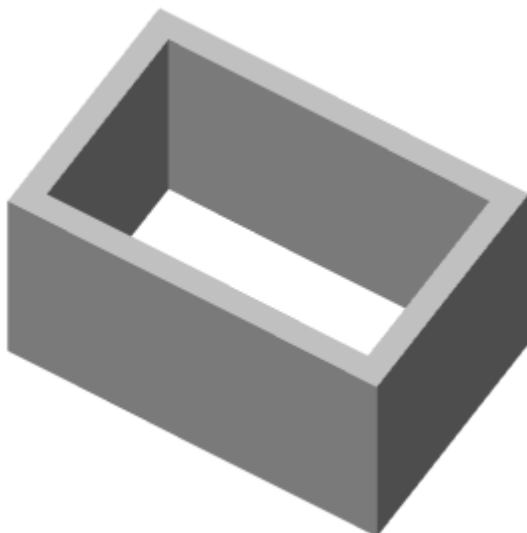

## *Presspull*



Main menu: **3D - 3D solid edit - Presspull**.



Ribbon: **3D Tools - 3D Solids - Presspull**.



Toolbar: **3D Edit - Presspull**.



Command line: **PRESSPULL**.

## *Procedure*

1. Call command **Presspull**.
2. Select a face or limited area.



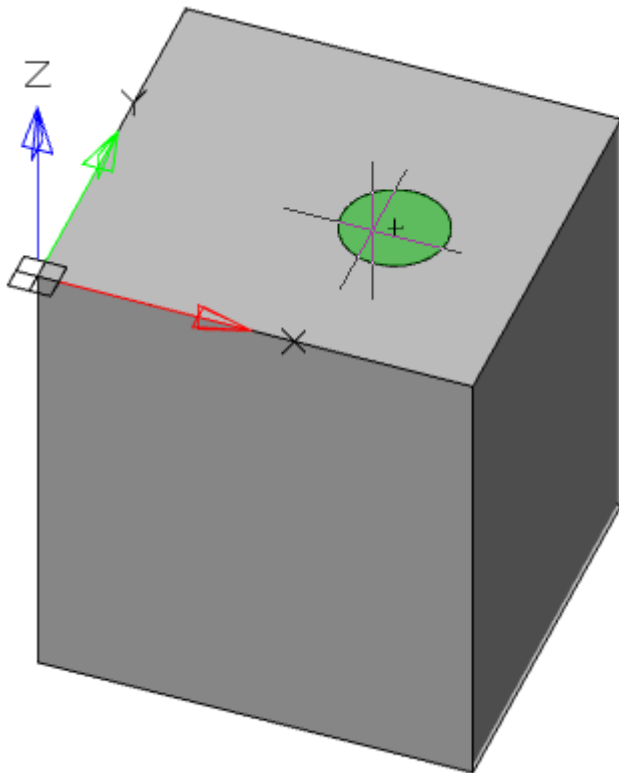

3. Use the **"Multiple"** context menu command if you need to specify multiple areas.
4. Set the extrusion distance. The value may be negative.
5. Extrusion of the face (closed area) will be performed.

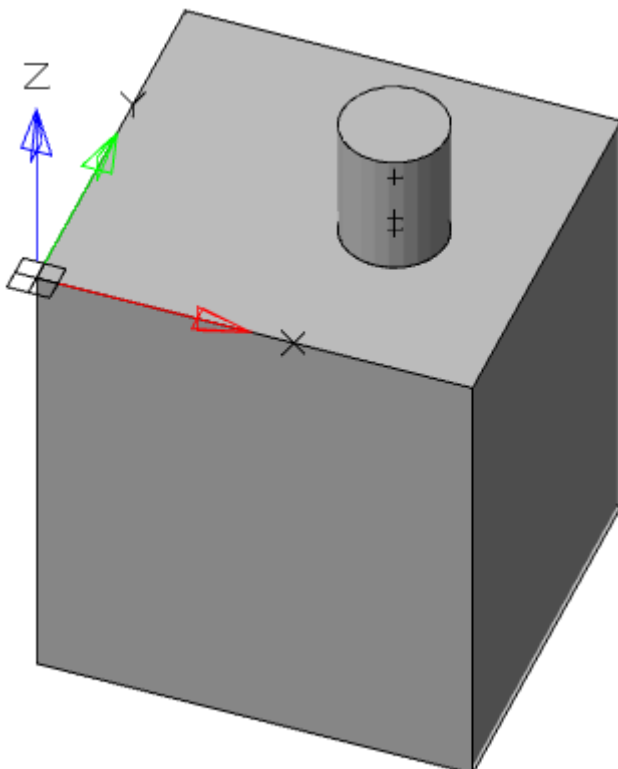

## Xedges





 Main menu: **3D - 3D solid edit - Xedges**.

 Ribbon: **3D Tools - 3D Solids - Xedges**.

 Toolbar: **3D Edit - Xedges**.

 Command line: **XEDGES**.

### Procedure

Object type	3D Solid
<b>General</b>	<b>3D Solid</b>
Layer	    0
Color	 By Layer
Linetype	————— By Layer
Linetype Scale	1.0000
Plot Style	By Color
Lineweight	————— By Layer
Hyperlink	
Transparency	ByLayer
<b>3D Visualization</b>	<b>—</b>
Material	ByLayer
<b>nanoCAD x64 Pro Int</b>	<b>—</b>
Scale	1:1
Part hatch	Type - [User-Defined]

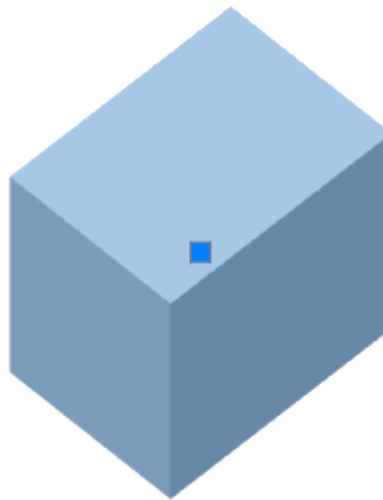

1. Call command  "**Xedges**".
2. Specify the 3D body from which you want to extract faces.
3. Faces will be extracted. The team will continue to work in a cyclical mode. To exit the cyclic mode, press the "**Esc**" key.

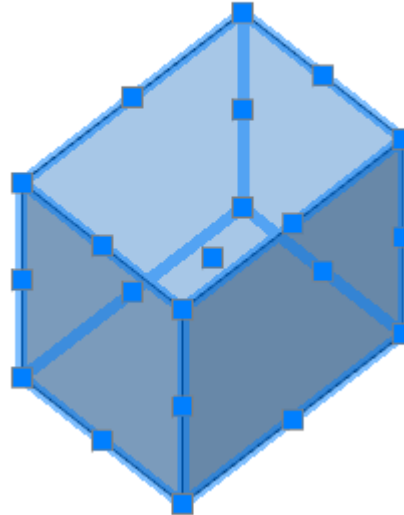
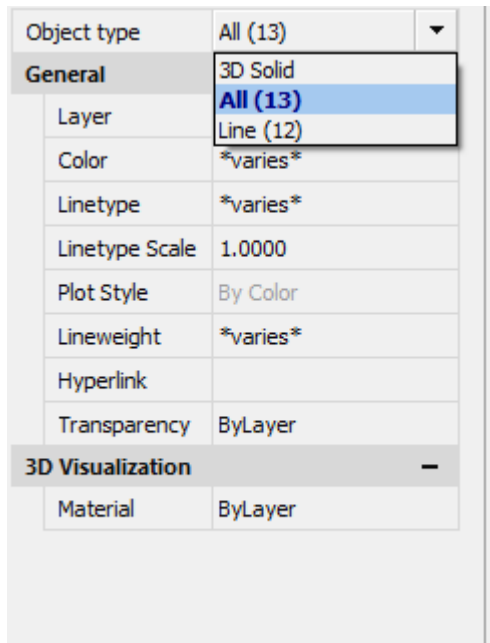

## Offset edge

 Main menu: **3D - 3D solid edit -  Offset edge.**

 Ribbon: **3D Tools - 3D Solids -  Offset Edge.**

 Toolbar: **3D Edit -  Offset edge.**

 Command line: **OFFSETEDGE.**

### Procedure

1. Call command  "Offset edge".
2. Specify the edge of the 3D body on which the contour will be built.

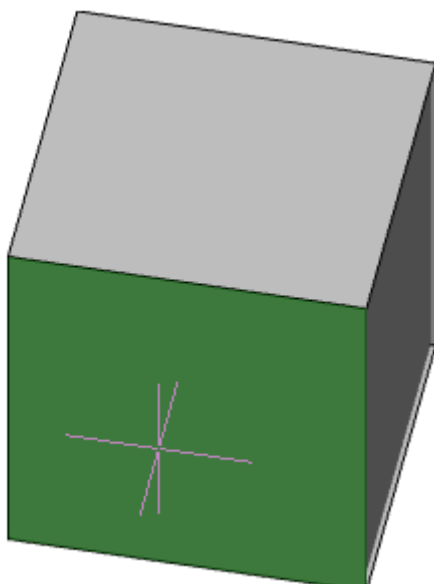

3. Specify the shape of the contour corners. Call the **"Corner"** command from the context menu or from the command line and select **"Round"** or **"Sharp"**. The radius of the round corners is equal to the size of the contour shift.

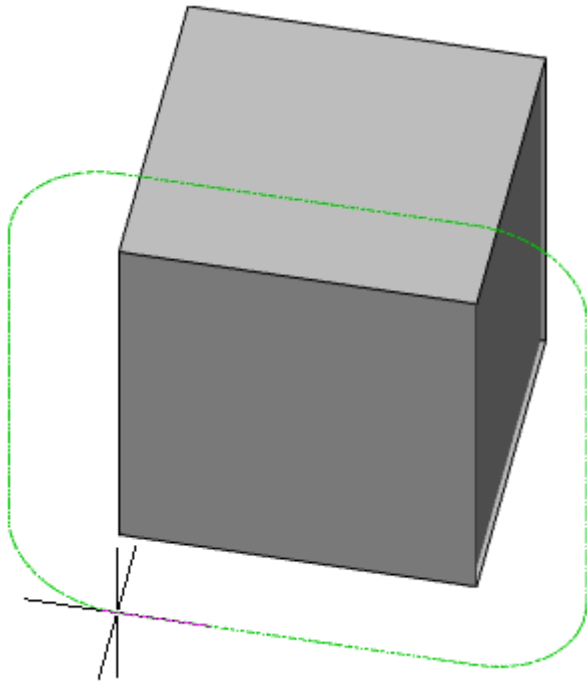

4. Specify the size of the contour shift. Call the command **"Distance"** from the context menu or from the command line and set the value.
5. Pick a point defining the side of the contour offset.
6. The contour of the face will be built.

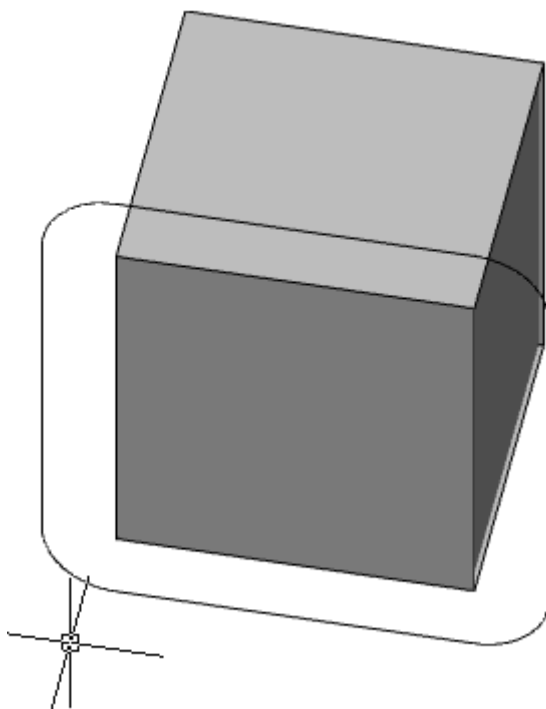

## Fillet edge

 Main menu: **3D - 3D solid edit - Fillet edge.**

 Ribbon: **3D Tools - 3D Solids - Fillet Edge.**

 Toolbar: **3D Edit - Fillet edge.**

 Command line: **FILLETEDGE.**

### Procedure

1. Call command  "**Fillet edge**".
2. Set the blend radius. Call the "Radius" command from the context menu or from the command line and specify the radius value.
3. Select the method for specifying the edges:
  - **Edge (default)** - edges are selected by sequential selection.
  - **Loop** - first one edge of the desired edge is selected, then the edge. All edges of the desired face are added to the set.
4. Specify edges in the selected way. All edges must have an adjacent face. To complete the selection, press the "**Enter**" key.

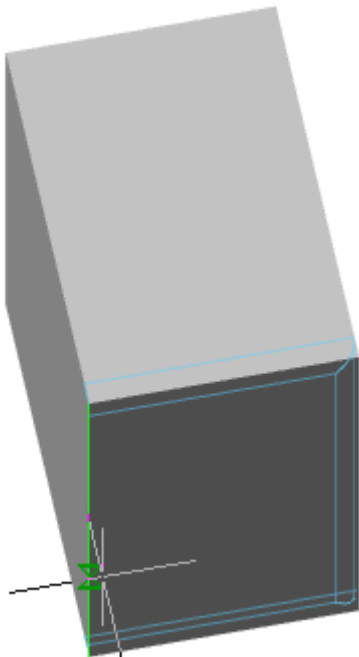

5. Check the resulting pairing. If necessary, change the radius.
6. Press the "**Enter**" key to confirm. Edge mate will be built.

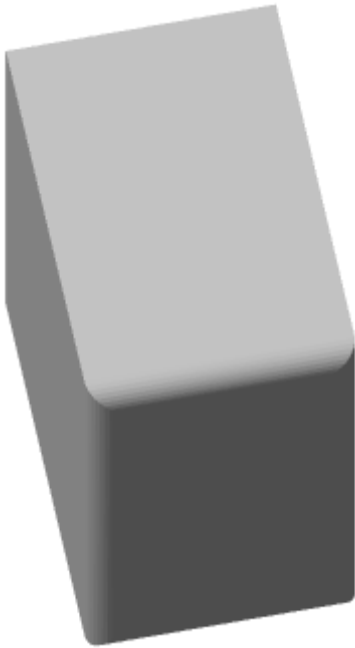

## *Chamfer edge*

 Main menu: **3D - 3D solid edit -  Chamfer edge.**

 Ribbon: **3D Tools - 3D Solids -  Chamfer Edge.**

 Toolbar: **3D Edit -  Chamfer edge.**

 Command line: **CHAMFEREDGE.**

## *Procedure*

1. Call command  "**Chamfer edge**".
2. Set the bevel distance. Call the "Distance" command from the context menu or from the command line and specify the distance value.
3. Select the method for specifying the edges:
  - **Edge (default)** - edges are selected by sequential selection.
  - **Loop** - first one edge of the desired edge is selected, then the edge. All edges of the desired face are added to the set.
4. Specify edges in the selected way. All edges must have an adjacent face. To complete the selection, press the "**Enter**" key.

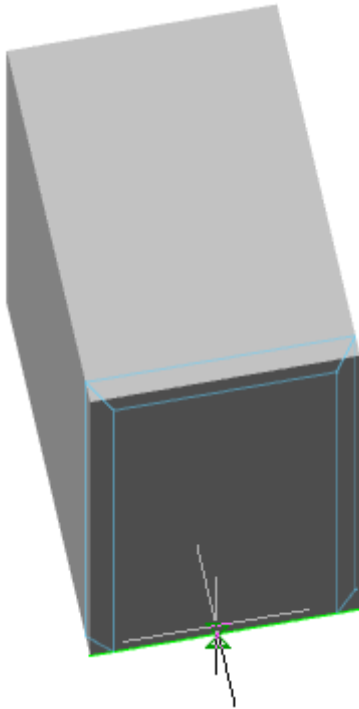

5. Check the chamfer. If necessary, change the distance.
6. Press the **"Enter"** key to confirm. Chamfer edge will be built.

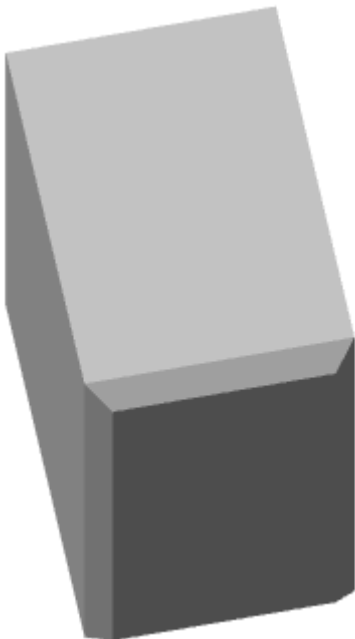

## *Solid editing*

 Main menu: **3D - 3D solid edit -  Solidedit.**

 Ribbon: **3D Tools - 3D Solids -  Solid Editing.**

 Toolbar: **3D Edit -  Solidedit.**

 Command line: **SOLIDEDIT**.

The team edits 3D solid, its faces and edges.

### Procedure

1. Call command  **"Solidedit"**.
2. Select the type of object to edit: Edge, Face, Body. For each type of object editing its menu of commands. To return the selection of the type of object being edited, press the **"Enter"** key.
3. Perform editing using the context menu commands:
  - **Color (Edge, Face)** - command sets new color.
    - Select the faces (edges) on which you want to change the color. To complete the selection, press the **"Enter"** key. Open dialog **"Select color"**.

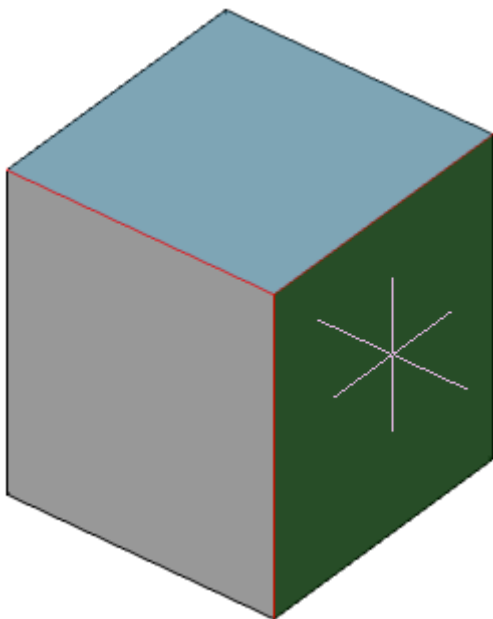

- In the **"Select color"** dialog box, define a new color in the way you like and click the "OK" button.

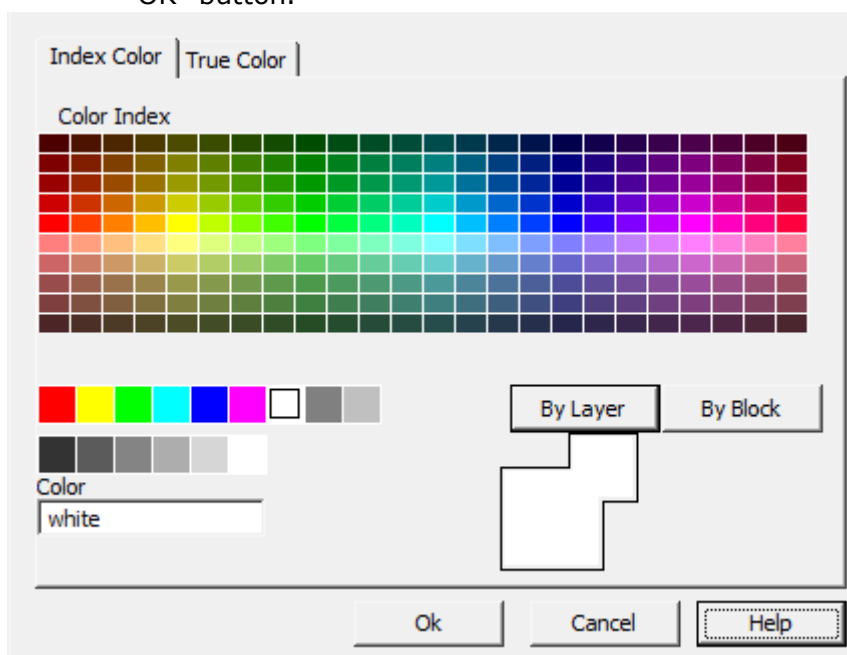

- New color will be applied.



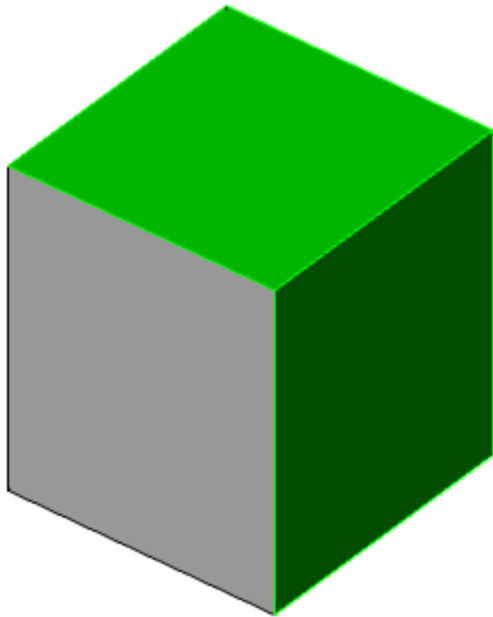

**Note:**

The change in the color of the edges can be seen on the visual styles with the edges shown.

When you change the color of the face, the colors of its edges change.

- **Copy (Edge, Face)** - allows you to copy a face (edge).
  - Select the faces (edges) on which you want to change the color. To complete the selection, press the **"Enter"** key.

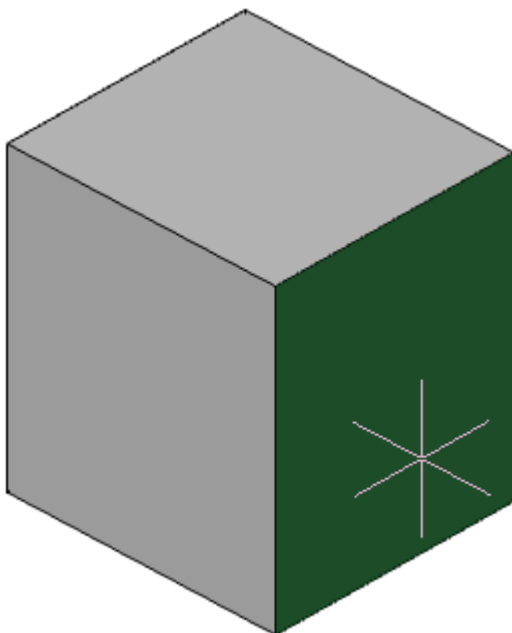

- Specify the base copy point.

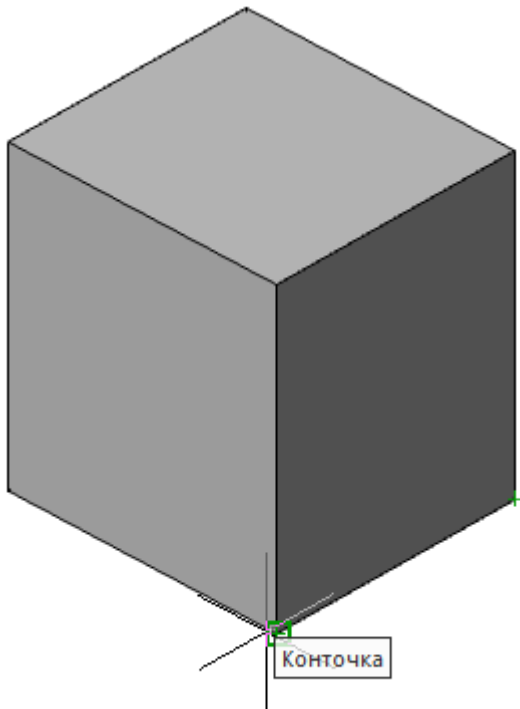

- Specify the end point to which the faces (edges) will be copied.

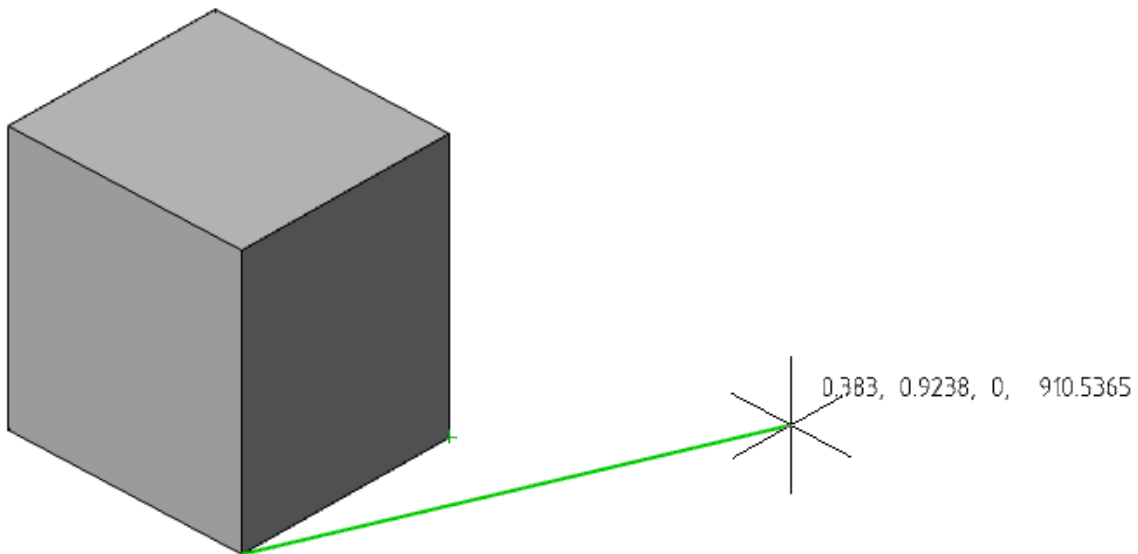

- Copy will be made. The face is copied as a region, the edge is a segment.

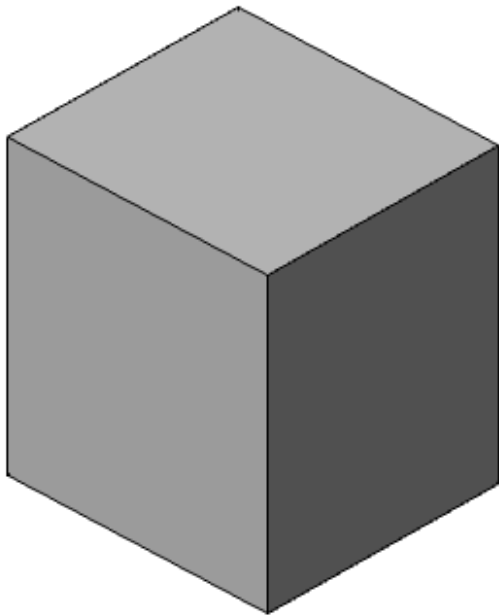

- **Imprint (Body)** - command action is similar to command action ["Imprint"](#).
- **Separate (body)** - command shares a body that has several kinks.

Select body. The body will be divided in the presence of kinks.

4. Use the editing commands of the selected object type (p. 3) the required number of times. To return to the choice of the type of object being edited (p. 2), press the **"Enter"** key.

5. The **"Solidedit"** command works in a cyclic mode. To end the command, press the **"Esc"** key.

## Sheet modeling

### Sheet solid

**Important!** This functionality requires a C3D 3D modeling engine.



Main menu: **3D - Sheet metal** -  **Sheet metal**.



Ribbon: **3D Tools - Sheet solids** -  **Sheet metal**.



Toolbar: **Sheet metal** -  **Sheet metal**.



Command line: **SMCREATE**.

The shape of the sheet solid is determined by its sketch. The order in which the sheet solid is drawn depends on whether the sketch is closed or open.

### Procedure

1. Draw a sketch: Closed or Open.

A closed sketch is extruded by a specified thickness in a direction perpendicular to its plane.

The following can act as a closed contour: closed polylines, circles, ovals.

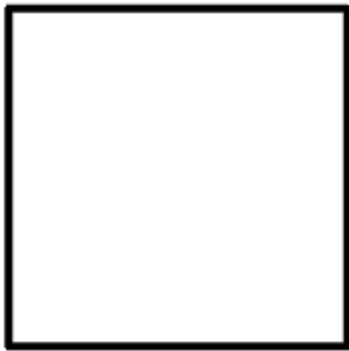



An open sketch is extruded to one or both sides by a specified distance; the thickness is added to the resulting surface. Sketch lines form flat sections of a sheet solid, arcs form bends of corresponding radius, and contour corners form bends with a user-defined inner radius.

The following can act as an open contour: open polylines with straight sections, lines, arcs.

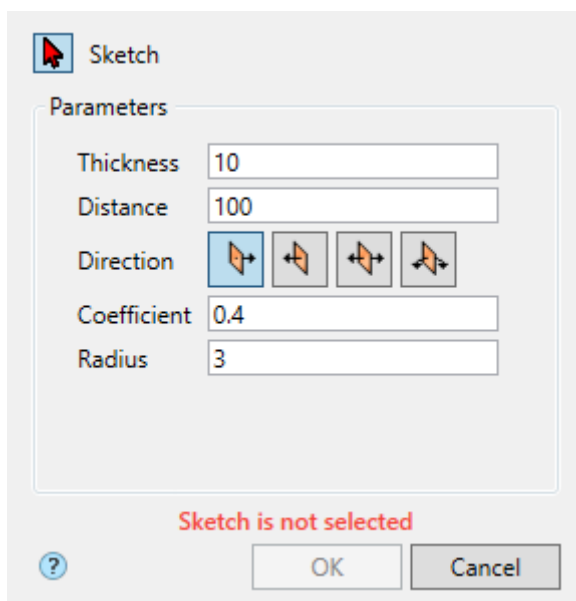

2. Call command Sheet solid. The  "Sheet solid" dialog will open.



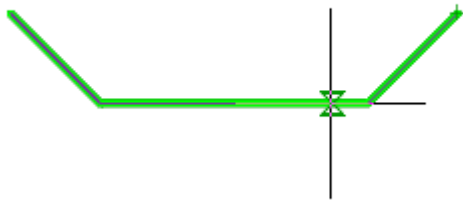

3. Select a sketch. A red cursor  means that the sketch selection mode is on. If a sketch is not selected, the corresponding red "**Sketch is not selected**" is displayed.



If you need to replace the sketch (select another), re-enter the sketch selection mode by clicking the **"Sketch"** button..

4. Specify the required parameters. Depending on the type of sketch, the composition of the parameters will change.

Open	Close
<div style="border: 1px solid #ccc; padding: 5px;"> <p>Parameters</p> <p>Thickness <input type="text" value="10"/></p> <p>Distance <input type="text" value="100"/></p> <p>Direction </p> <p>Coefficient <input type="text" value="0.4"/></p> <p>Radius <input type="text" value="3"/></p> </div>	<div style="border: 1px solid #ccc; padding: 5px;"> <p>Parameters</p> <p>Thickness <input type="text" value="10"/></p> <p>Direction </p> </div>

Confirm the action on the **"OK"** button. The sheet body will be built. If the **"OK"** button is grayed out, it means that the sketch was not selected or the parameters were set incorrectly. In the **"3d History"**, a  **"Sheet metal"** object containing a sketch will be created with reference to an existing or new body.

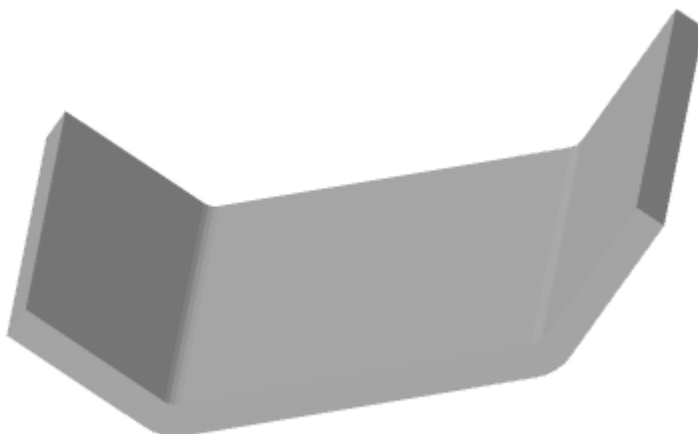

## Dialog

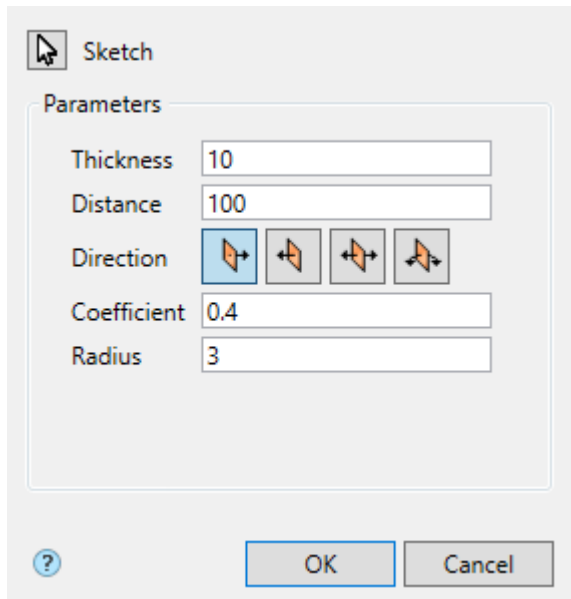





Button  **"Sketch"** - turns on the sketch selection mode in the drawing.

Field **"Thickness"** - sheet body thickness.

Field **"Distance"** - sheet body length, if a closed sketch is specified, the field defines the thickness of the sheet body.

Field **"Distance 2"** - the length of the sheet body when the direction **"Both directions"** is selected, if a closed sketch is specified, the field determines the thickness of the sheet body.

Direction select switch group:

-  **Forward direction** - directs the extrusion toward the positive direction of the axis perpendicular to the sketch plane.
-  **Reverse direction** - directs the extrusion toward the negative direction of the axis perpendicular to the sketch plane.
-  **Both direction** - directs the extrusion to both sides of the sketch plane, the distances are determined by the **"Distance"** and **"Distance 2"** parameters.
-  **Middle plane** - directs the extrusion to both sides of the sketch plane at the same distance.

Field **"Coefficient"** - neutral layer coefficient.

Field **"Radius"** - radius of connection of straight sections.

## 3D History

 **"Sheet metal"**. As part of the  body.

The following context menu commands are available:

- **Edit** - calls the object for editing. The edit symbol appears to the right of the icon .
- **Rename (F2)** - allows you to rename an object.
- **Delete (Del)** - removes an object from tree and model space.
- **Suppress** - removes an object from model space.
- **Unsuppress** - restores the object in model space.
- **ShowInDocument** - focuses and highlights the subject in the center of model space.
- **Rebuild** - rebuilds an object in model space.

## Shell

**Important!** This functionality requires a C3D 3D modeling engine.

 Main menu: **3D - Sheet metal - Shell**.

 Ribbon: **3D Tools - Sheet solids - Shell**.

 Toolbar: **Sheet metal - Shell**.

 Command line: **SMSHELL**.

The sectional shape of the shell is determined by its sketch. A simple shell is formed by extruding a sketch in a direction perpendicular to its plane and adding thickness to the resulting surface. A sketch outline can be closed or open. If the contour is closed, then the shell is cut in height, the location and size of the gap are specified by the user. Various methods of trimming the shell edges are possible.

Sketch lines form flat portions of the shell, and contour corners form bends with a user-defined radius.

### Procedure

1. Draw a sketch. The sketch can be closed or open.

The following can act as a closed contour: closed polylines, circles, ovals.

An open contour can be: open polylines, lines, arcs, open splines.

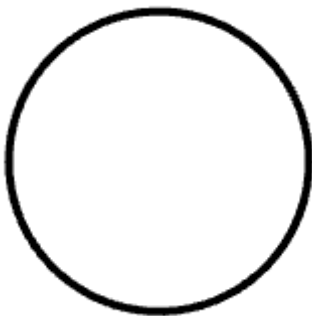

2. Call command **Shell**. The **Shell** dialog will open.

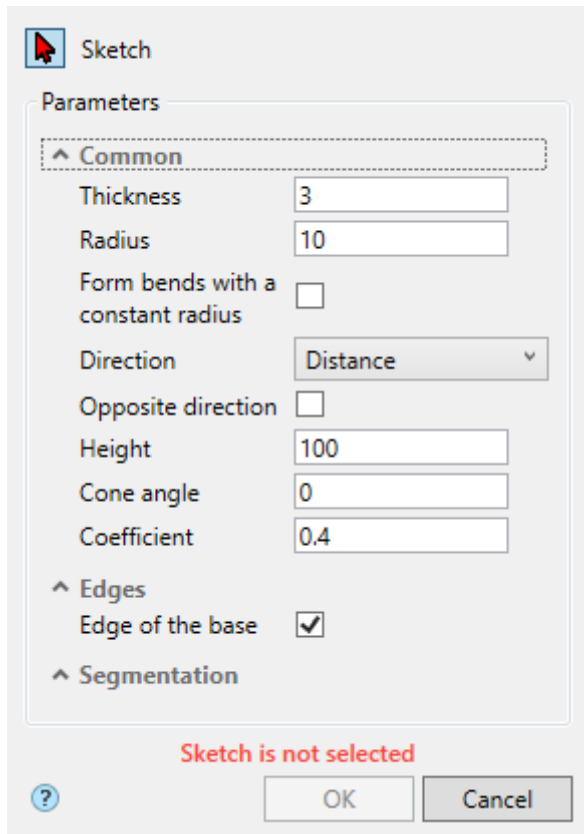

3. Select a sketch. A red cursor  means that the sketch selection mode is on. If a sketch is not selected, the corresponding red **"Sketch is not selected"** is displayed.

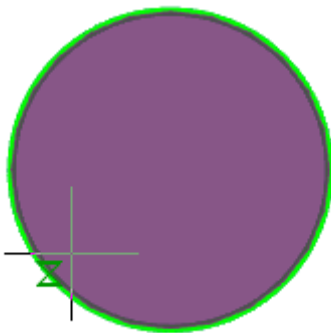

If you need to replace the sketch (select another), re-enter the sketch selection mode by clicking the  **"Sketch"** button.

4. Specify the required parameters. Depending on the type of sketch, the composition of the parameters will change. For a contour with arcs, the segmentation options become available.

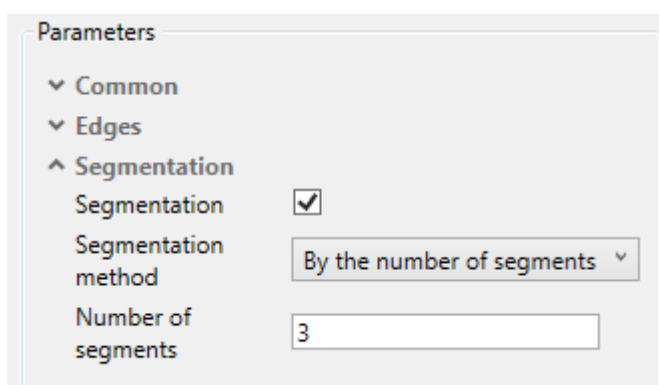



5. Confirm the action with the **"OK"** button. The sheet solid will be built. If the **"OK"** button is grayed out, it means that the sketch was not selected or the parameters were set incorrectly. In **"3d History"**, a  **"Shell"** object containing the sketch will be created and snapped to an existing or new solid.



### Dialog

Sketch

**Parameters**

^ Common

Thickness

Radius

Form bends with a constant radius

Direction

Opposite direction

Height

Cone angle

Coefficient

^ Edges

The edge of a joint

Edge of the base

Gap value

Gap shift type

Gap shift

^ Segmentation

Segmentation

Segmentation method

Number of segments

 ?

## 3D History

 "Shell". As part of the  body.

The following context menu commands are available:

- **Edit** - calls the object for editing. The edit symbol appears to the right of the icon .
- **Rename (F2)** - allows you to rename an object.
- **Delete (Del)** - removes an object from tree and model space.
- **Suppress** - removes an object from model space.
- **Unsuppress** - restores the object in model space.
- **ShowInDocument** - focuses and highlights the subject in the center of model space.
- **Rebuild** - rebuilds an object in model space.

## Ruled shell

**Important!** This functionality requires a C3D 3D modeling engine.

 Main menu: **3D - Sheet metal -  Ruled shellSheet metal.**

 Ribbon: **3D Tools - Sheet solids -  Ruled shella.**

 Toolbar: **Sheet metal -  Ruled shell.**

 Command line: **SMRULEDSHELL.**

The sectional shape of the shell is determined by its sketch. Two sketches are required for the construction of the ruled shell. A sketch outline can be closed or open. If the contour is closed, then the shell is cut in height, the location and size of the gap are specified by the user. Various methods of trimming the shell edges are possible.

## Procedure

1. Draw 2 sketches. The sketch can be closed or open.

The following can act as a closed contour: closed polylines, circles, ovals.

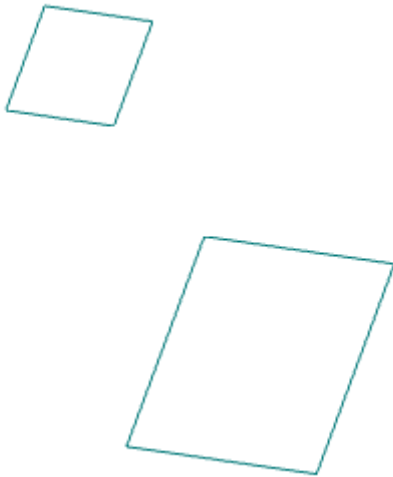

An open contour can be: open polylines, lines, arcs, open splines.

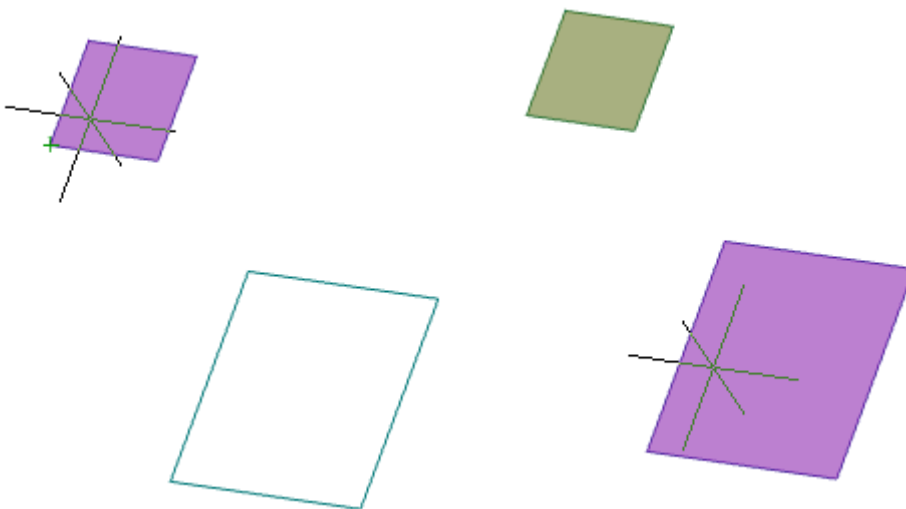

2. Call command  **"Ruled shell"**. The **"Ruled shell"** dialog will open.

3. Select 2 sketches. A red cursor  means that the sketch selection mode is on. If no sketches are selected, the corresponding red text **"Sketch 1, Sketch 2 are not selected"** is displayed.





If you need to replace the sketch (select another), re-enter sketch selection mode by pressing the  **"Sketch 1"** or  **"Sketch 2"** button.

4. Specify the required parameters.

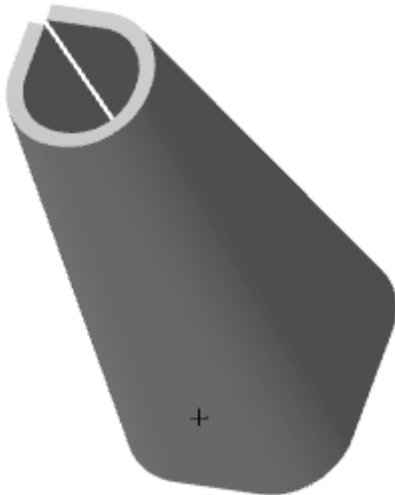
5. Confirm the action with the **"OK"** button. The ruled shell will be built. If the **"OK"** button is grayed out, it means that no sketches were selected or the parameters were set incorrectly. In **"3d History"**, a  **"Ruled shell"** object containing sketches will be created and snapped to an existing or new solid.



### Dialog

	Sketch 1
	Sketch 2
<b>Parameters</b>	
Thickness	<input type="text" value="3"/>
Radius	<input type="text" value="10"/>
Form bends with a constant radius	<input type="checkbox"/>
Coefficient	<input type="text" value="0.4"/>
The edge of a joint	<input checked="" type="checkbox"/>
Edge of the base	<input checked="" type="checkbox"/>
Gap value	<input type="text" value="2"/>
Gap shift type	<input type="text" value="Length"/>
Gap shift	<input type="text" value="0"/>
	<input type="button" value="OK"/> <input type="button" value="Cancel"/>

### 3D History

 "Ruled shell". As part of the  body.

The following context menu commands are available:

- **Edit** - calls the object for editing. The edit symbol appears to the right of the icon .
- **Rename (F2)** - allows you to rename an object.
- **Delete (Del)** - removes an object from tree and model space.
- **Suppress** - removes an object from model space.
- **Unsuppress** - restores the object in model space.
- **ShowInDocument** - focuses and highlights the subject in the center of model space.
- **Rebuild** - rebuilds an object in model space.

## Plate

### Important!

This functionality requires a C3D 3D modeling engine.



Main menu: **3D - Sheet metal - Plate**.



Ribbon: **3D Tools - Sheet solids - Plate**.



Toolbar: **Sheet metal - Plate**.



Command line: **SMPLATE**.

A plate is a flat sheet metal piece glued to a sheet metal piece. The plate is formed by extruding a closed sketch. The extrusion depth can be arbitrary or equal to the thickness of the sheet metal.

### Procedure

1. Draw a closed loop sketch. The sketch must be positioned on the outer or inner planar face of the sheet solid.

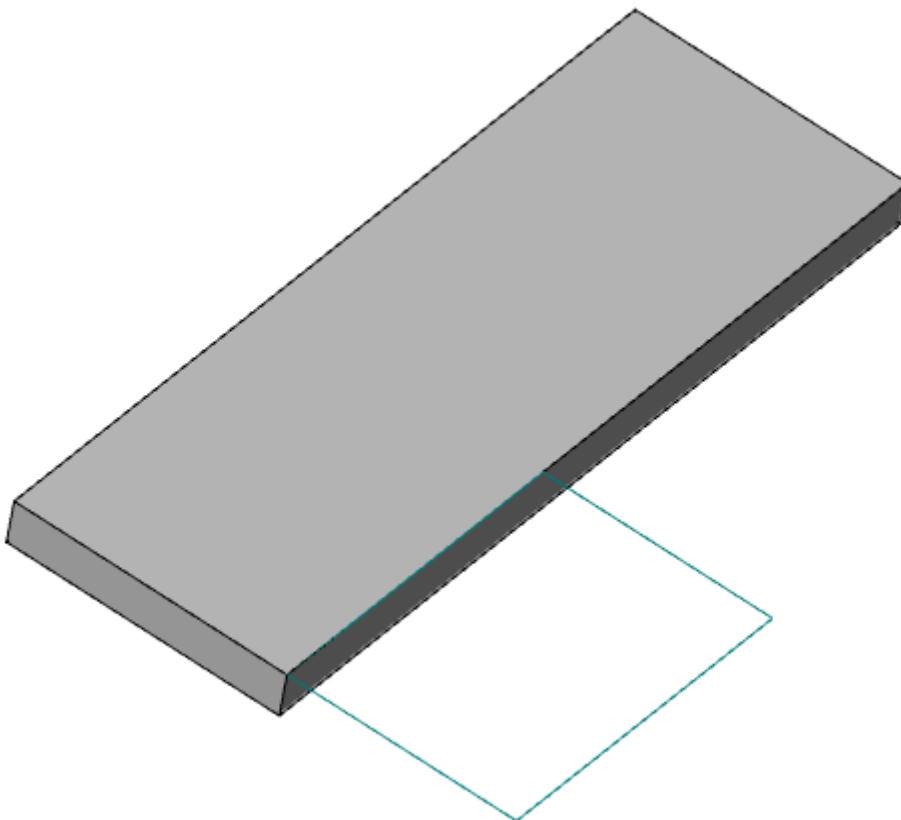

2. Call command **"Plate"**. The **"Plate"** dialog will open.

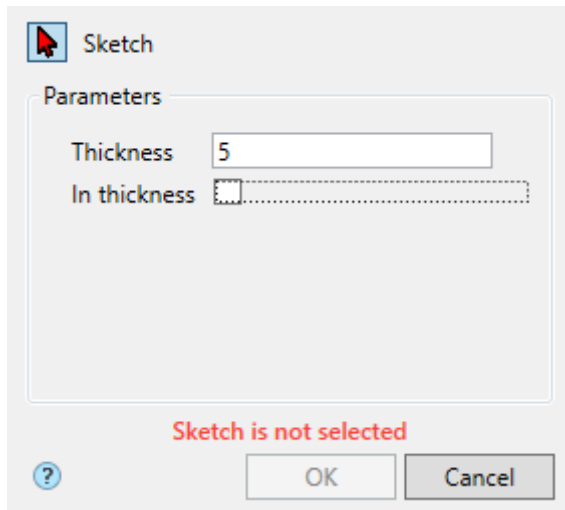

3. Select a sketch. A red cursor  means that the sketch selection mode is on. If a sketch is not selected, the corresponding red "**Sketch is not selected**" is displayed.

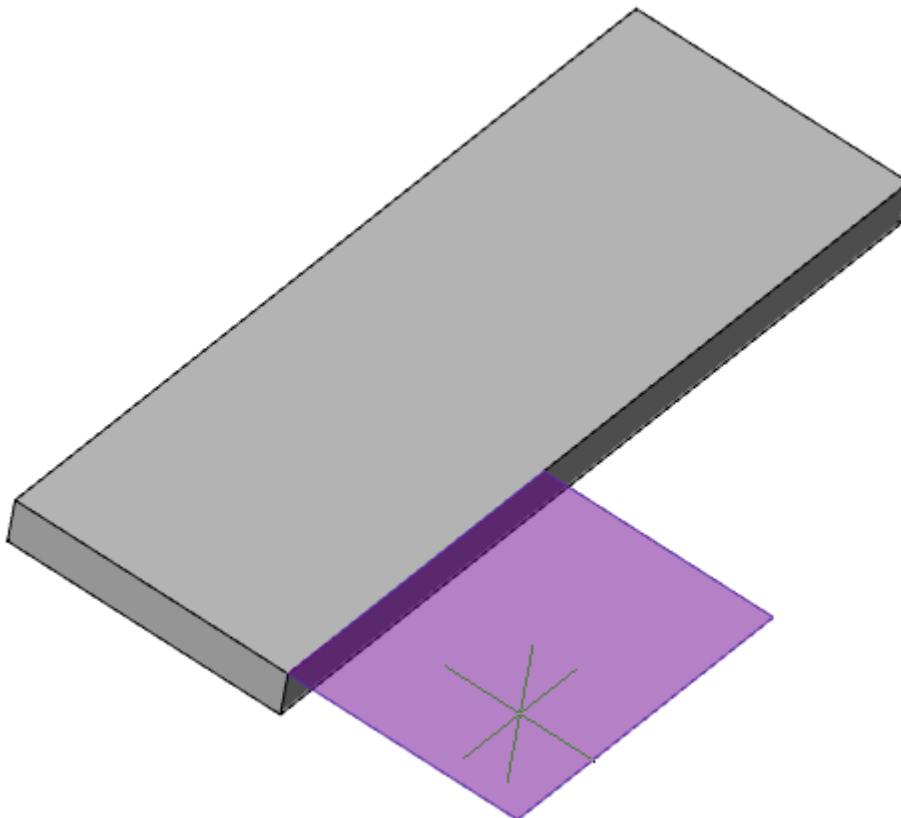

If you need to replace the sketch (select another), re-enter the sketch selection mode by clicking the  "**Sketch**" button.

4. Specify the required parameters.

5. Confirm the action with the "**OK**" button. The sheet solid will be built. If the "**OK**" button is grayed out, it means that the sketch was not selected or the parameters were set incorrectly. In "**3d History**", a  "**Plate**" object containing the sketch will be created and snapped to an existing or new solid.

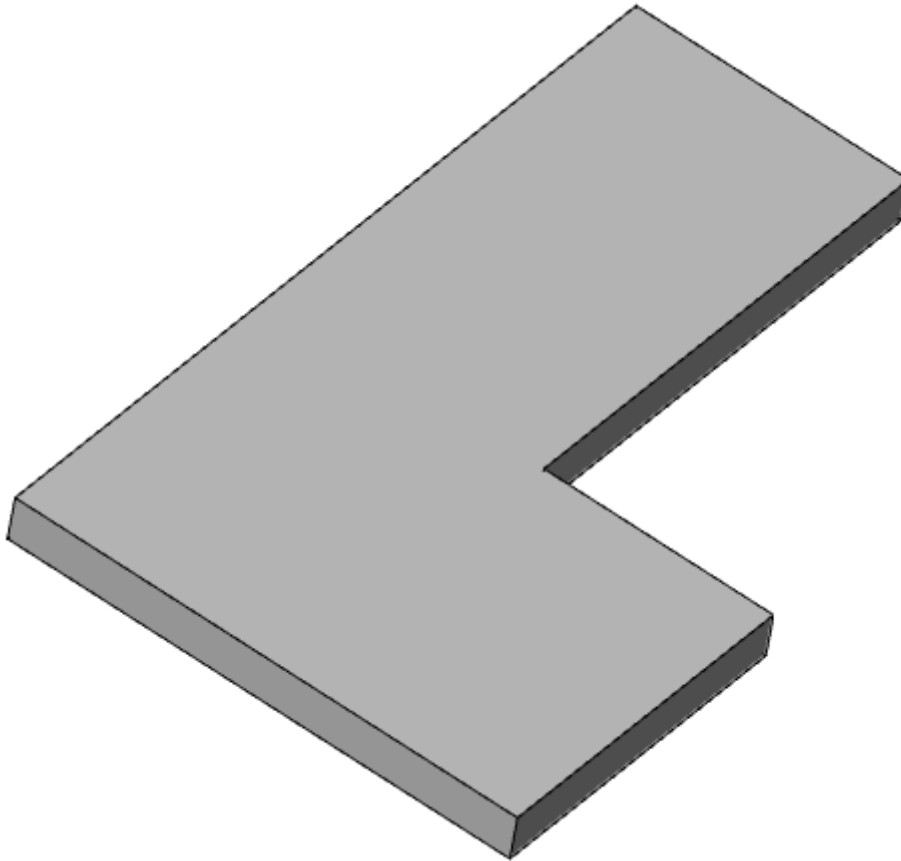

### Dialog

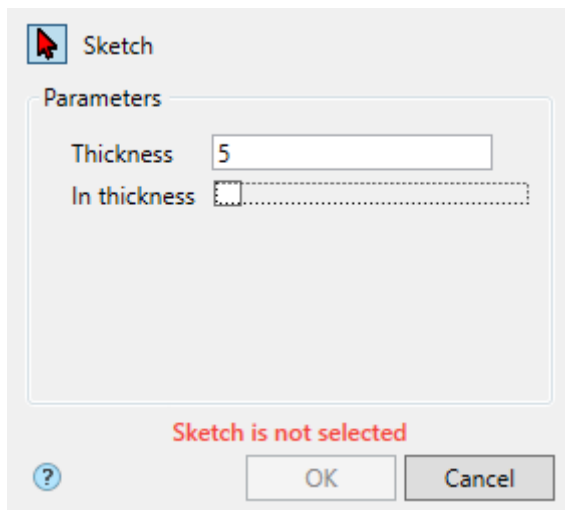

Button  **"Sketch"** - turns on the sketch selection mode in the drawing.

Field **"Thickness"** - plate thickness.

Switch **"In thickness"** - when the switch is on, the thickness of the plate is equal to the thickness of the sheet, the **"Thickness"** field is hidden.

### 3D History

 **"Plate"**. As part of the  body.

The following context menu commands are available:

- **Edit** - calls the object for editing. The edit symbol appears to the right of the icon ⚡.
- **Rename (F2)** - allows you to rename an object.
- **Delete (Del)** - removes an object from tree and model space.
- **Suppress** - removes an object from model space.
- **Unsuppress** - restores the object in model space.
- **ShowInDocument** - focuses and highlights the subject in the center of model space.
- **Rebuild** - rebuilds an object in model space.

## Bend along edge

**Important!** This functionality requires a C3D 3D modeling engine.

 Main menu: **3D - Sheet metal -  Bend along edge.**

 Ribbon: **3D Tools - Sheet solids -  Bend along edge.**

 Toolbar: **Sheet metal -  Bend along edge.**

 Command line: **SMEDGE.**

A bend is created along one or more edges of the sheet metal. The edge (s) must be straight and belong to the outer or inner flat face of the sheet metal.

### Procedure

1. Call command  **"Bend along edge"**. The **"Bend along edge"** dialog will open.

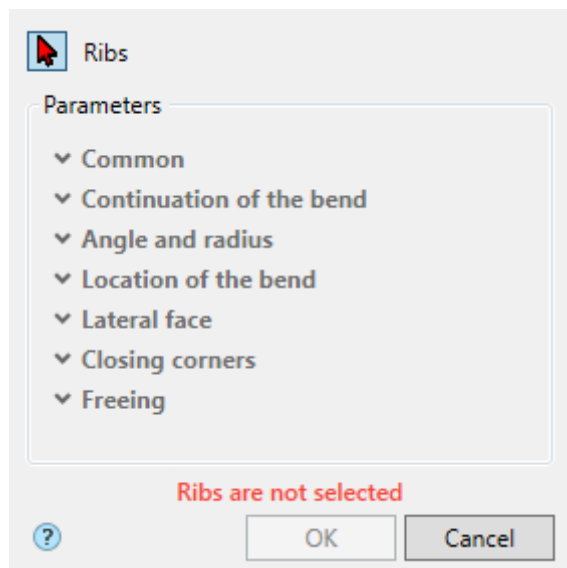

2. Select an edge. Red cursor  means selection mode is on. If an edge is not selected, the corresponding red text **"Ribs are not selected"** is displayed.



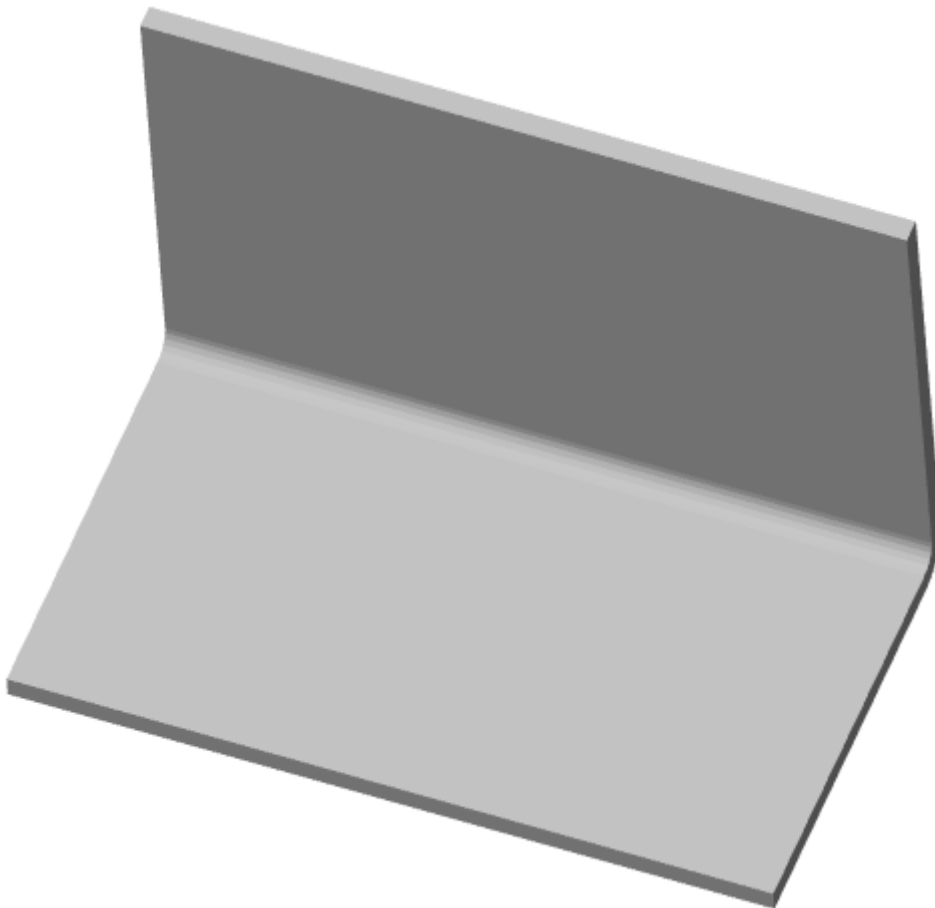
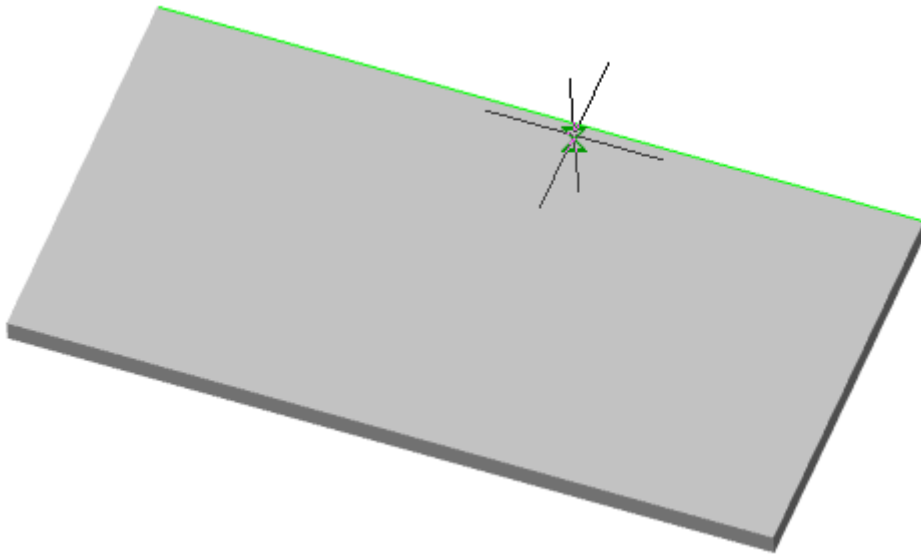

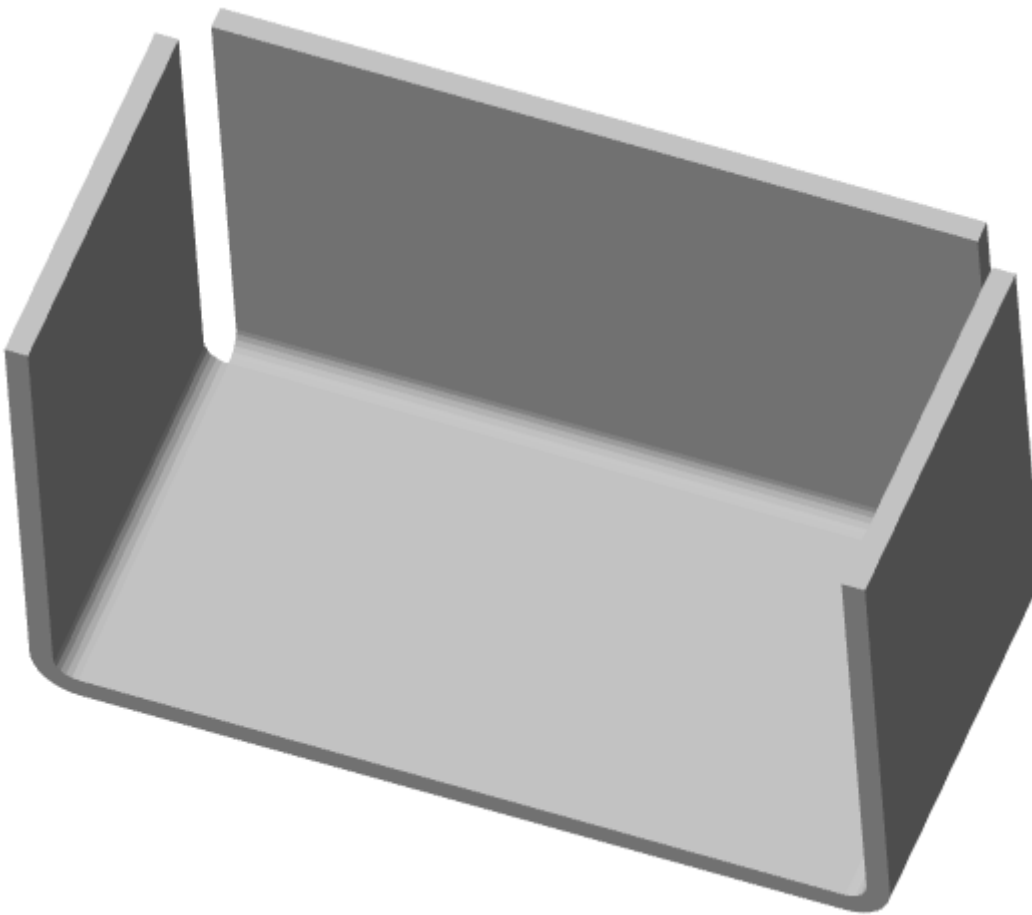
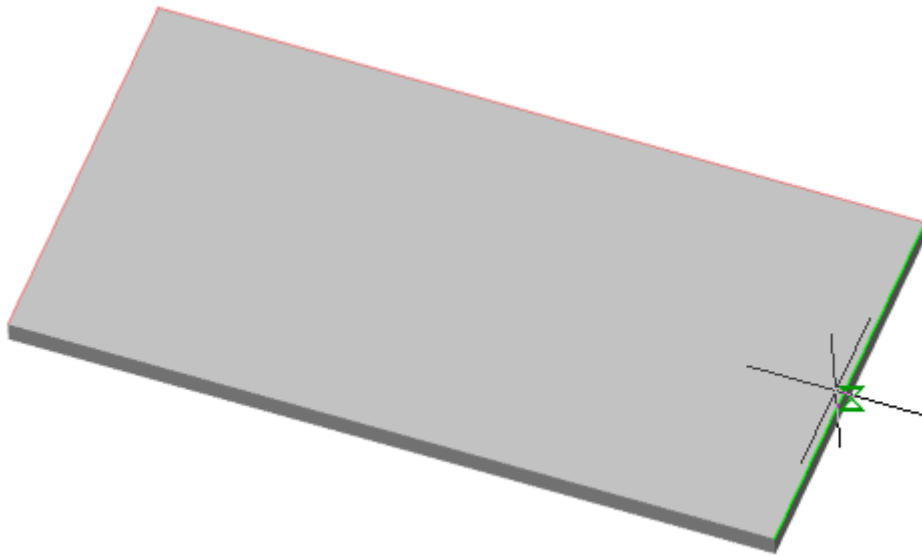

If you need to remove or add an edge, enter the selection mode again by pressing the  **"Ribs"** button. Selected edges are highlighted in red, re-selecting an edge removes the selection.

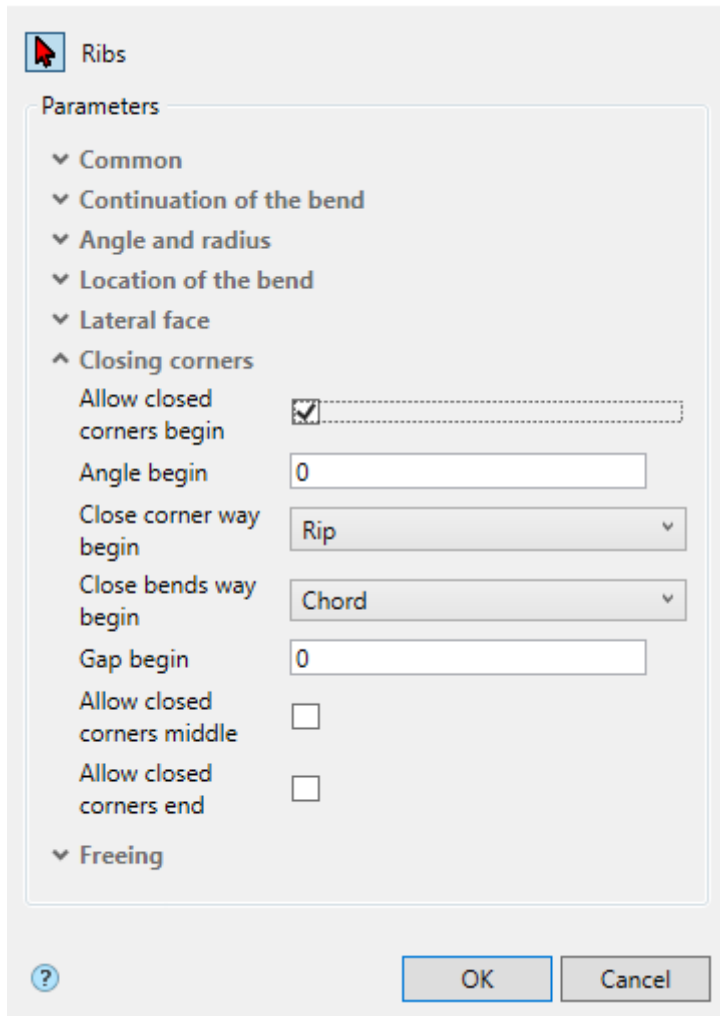

3. Specify the required parameters.



4. Confirm the action with the **"OK"** button. The bend will be built. If the **"OK"** button is inactive, it means that an edge was not selected or the parameters were set incorrectly. A  **"Bend along edge"** object will be created in **"3d History"** and will snap to an existing or new solid.

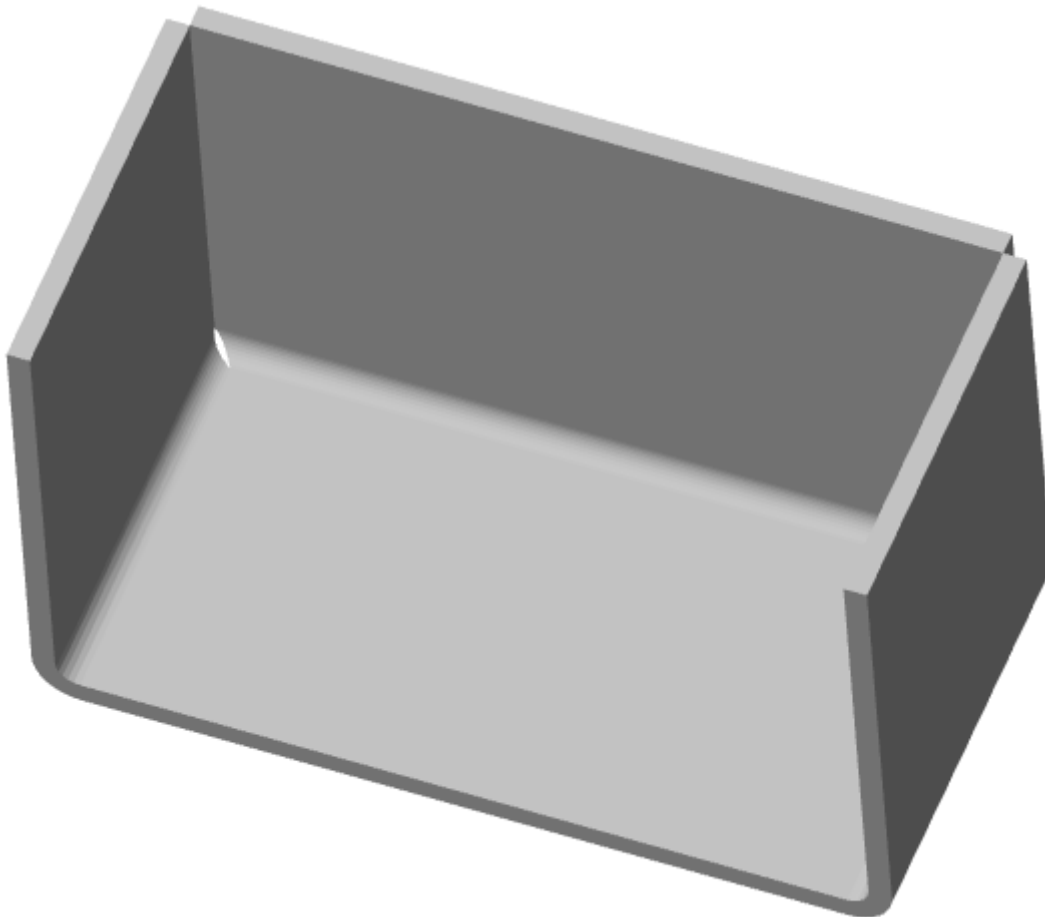

## Dialog

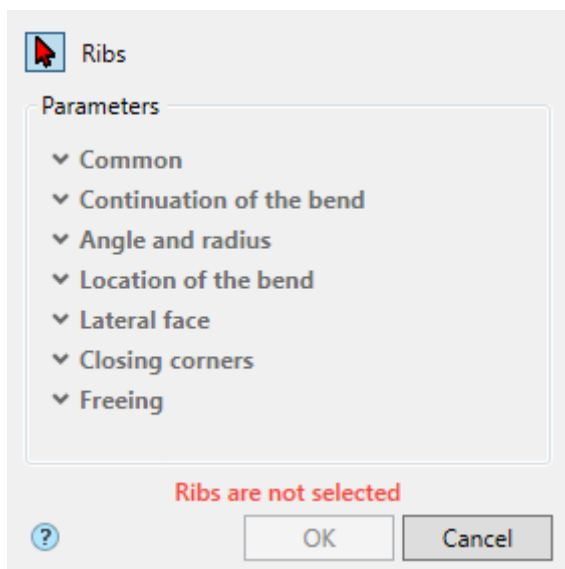

Button  **"Ribs"** - turns on the ribs selection mode in the drawing.

## Common



### Continuation of the bend

^ Continuation of the bend  
 Length type Length from bend v  
 Length 100

### Angle and radius

^ Angle and radius  
 Radius type Internal v  
 Radius 5  
 Angle type Angle bend v  
 Angle 90

### Location of the bend

^ Location of the bend  
 Type of offset bend Offset inside v  
 Displacement 0

### Lateral face

^ Lateral face  
 Extension bend left   
 Slope bend left 0  
 Slope left 0  
 Extension bend right   
 Slope bend right 0  
 Slope right 0  
 ^ Lateral face  
 Extension bend left   
 Widening left 0  
 Extension bend right   
 Widening right 0

### Closing corners

^ Closing corners

Allow closed corners begin

Angle begin

Close corner way begin

Close bends way begin

Gap begin

Allow closed corners middle

Close corner way middle

Close bends way middle

Gap middle

Allow closed corners end

Angle end

Close corner way end

Close bends way end

Gap end

## Freeing

^ Freeing

Release bend

Rounded fold release



Width slot

Depth slot

Include the width of the bend

Freeing the corner

## 3D History







 "Bend along edge". As part of the  body.

The following context menu commands are available:

- **Edit** - calls the object for editing. The edit symbol appears to the right of the icon .
- **Rename (F2)** - allows you to rename an object.
- **Delete (Del)** - removes an object from tree and model space.
- **Suppress** - removes an object from model space.
- **Unsuppress** - restores the object in model space.
- **ShowInDocument** - focuses and highlights the subject in the center of model space.
- **Rebuild** - rebuilds an object in model space.

## *Bend by sketch*

**Important!** This functionality requires a C3D 3D modeling engine.

-  Main menu: **3D - Sheet metal -  Fold by sketch.**
-  Ribbon: **3D Tools - Sheet solids -  Fold by sketch.**
-  Toolbar: **Sheet metal -  Fold by sketch.**
-  Command line: **SMJOINTBEND.**

Fold by sketch - A multi-bend feature whose profile is defined by a contour in a sketch. The corners of a path in a sketch form bends with a user-defined inner radius.

### *Procedure*

1. Draw a sketch. The bend should be located along one straight edge or chain of straight edges of the sheet metal part. The edge is the bend line, and the containing face (outside or inside) is the base face of the bend.

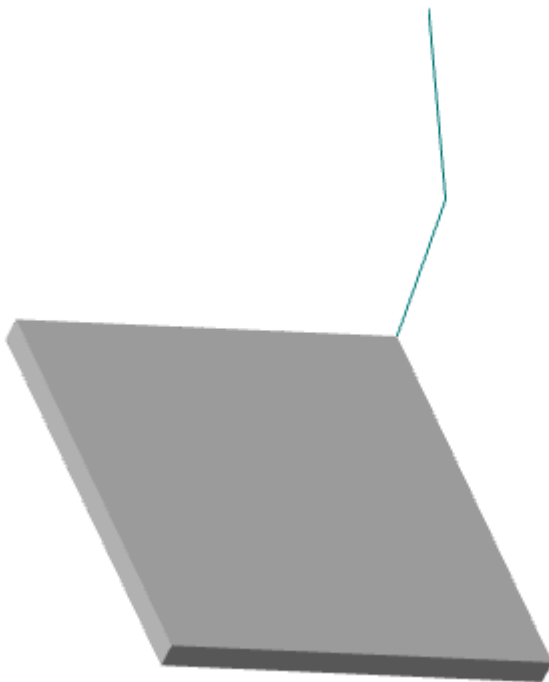

2. Call command  "**Fold by sketch**". The "**Fold by sketch**" dialog will open.

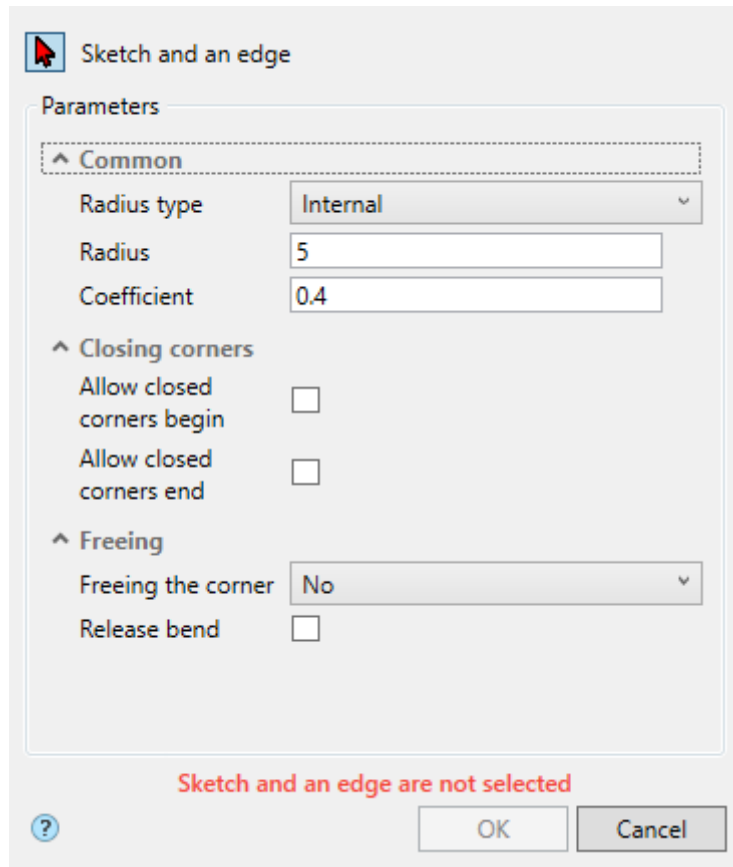

3. Select the sketch (path) and the edge of the sheet solid. Red cursor  means selection mode is on.

If the path and edge of the sheet solid are not selected, the corresponding red **"Sketch and an edge are not selected"** text box is displayed.



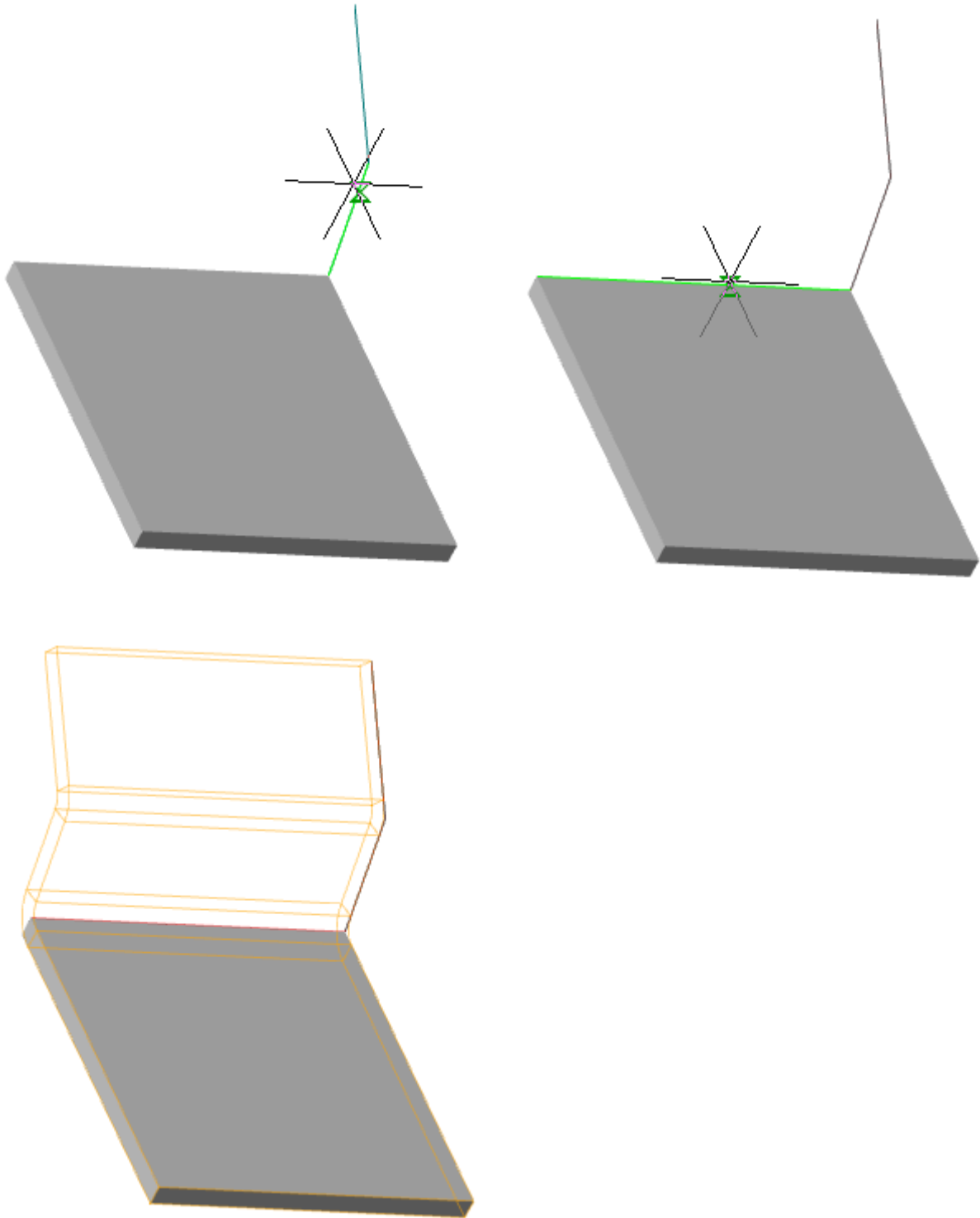

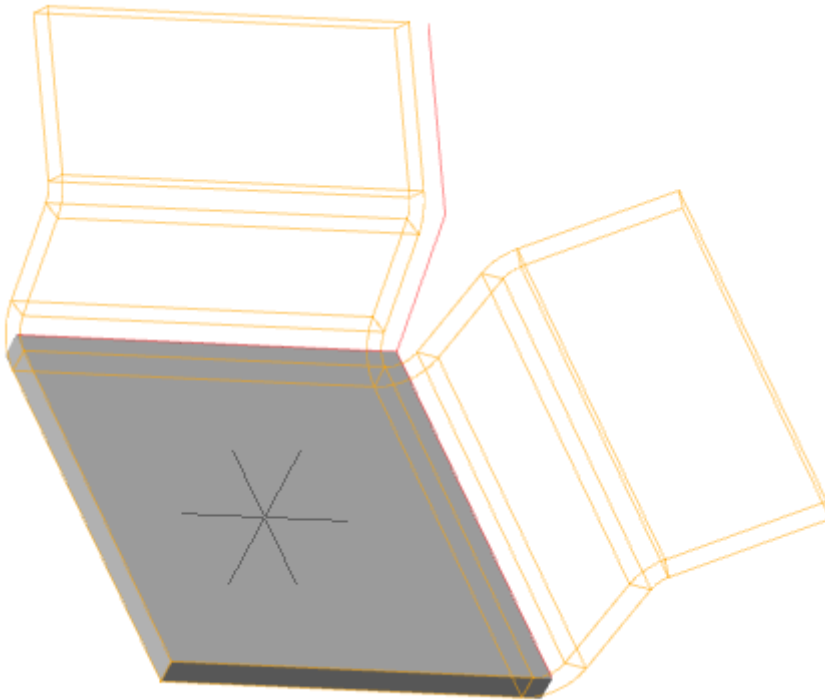

Pick multiple edges of the sheet body, if necessary.



Press the  **"Sketch and an edge"** button to complete your selection.

If you need to replace or add objects, enter the selection mode again by pressing the  **"Sketch and an edge"** button.

4. Specify the required parameters.

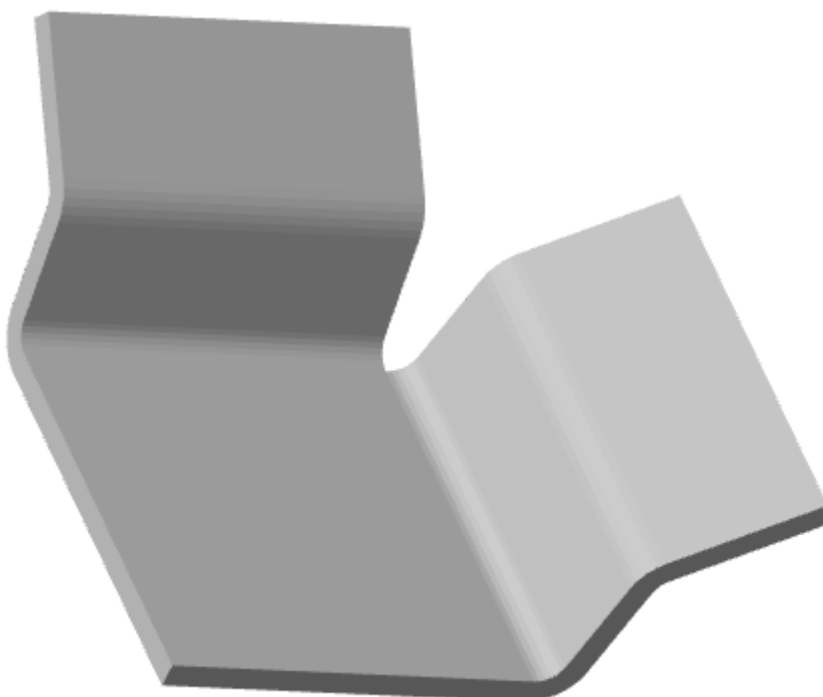

5. Confirm the action with the **"OK"** button. The fold by sketch will be constructed. If the **"OK"** button is grayed out, it means that the path and edges were not selected or the parameters were set incorrectly. In **"3d History"**, a  **"Fold by Sketch"** object is created that contains the sketch and snapped to an existing or new solid.

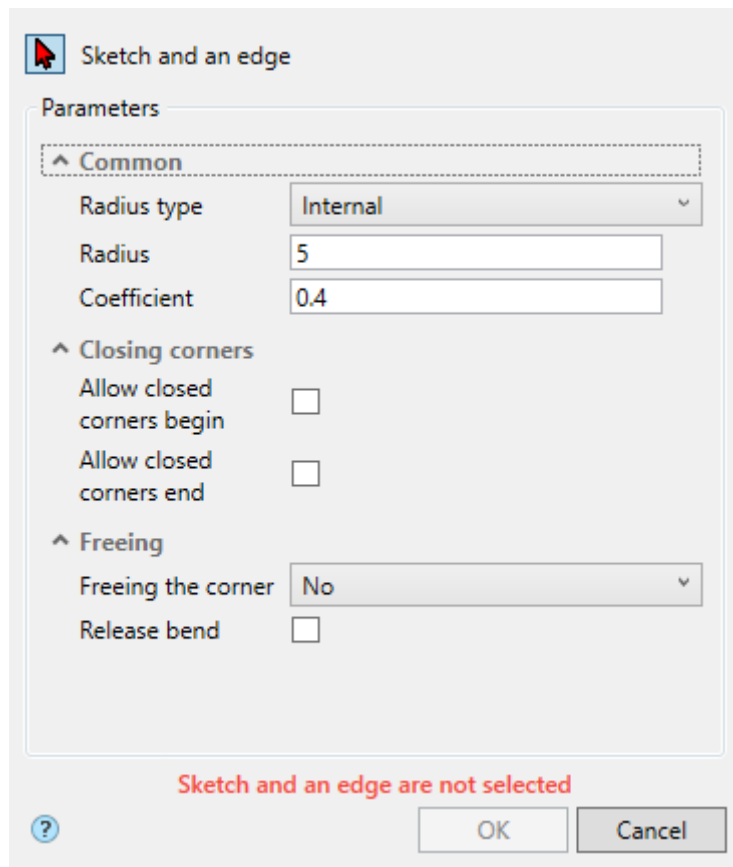

## Dialog



## 3D History

 "Fold by sketch". As part of the  body.

The following context menu commands are available:

- **Edit** - calls the object for editing. The edit symbol appears to the right of the icon .
- **Rename (F2)** - allows you to rename an object.
- **Delete (Del)** - removes an object from tree and model space.
- **Suppress** - removes an object from model space.
- **Unsuppress** - restores the object in model space.
- **ShowInDocument** - focuses and highlights the subject in the center of model space.
- **Rebuild** - rebuilds an object in model space.

## Bend along line

**Important!** This functionality requires a C3D 3D modeling engine.

 Main menu: **3D - Sheet metal -  Bend along line.**

 Ribbon: **3D Tools - Sheet solids -  Bend along line.**

 Toolbar: **Sheet metal -  Bend along line.**

 Command line: **SMOVERSEG**.

A sheet metal part can be bent in a straight line relative to the outer or inner flat face of that part. The specified line and face will be the bend line and bend base face.

### Procedure

1. Draw a bend line. The line can be a separate primitive or part of a sketch. The bend line must intersect the body completely.

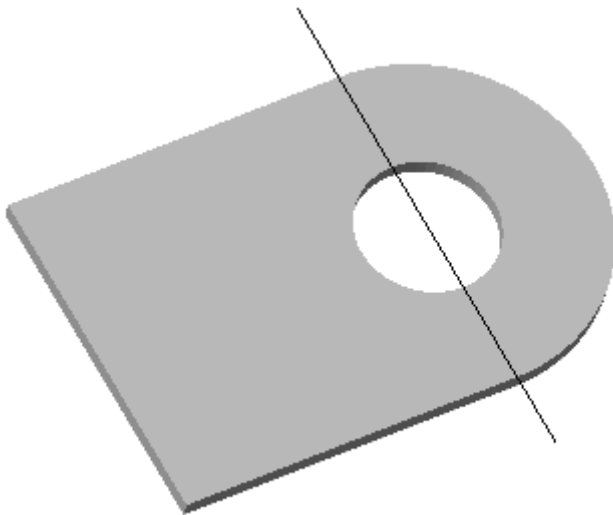

2. Call command  "**Bend along line**". The "**Bend along line**" dialog will open.

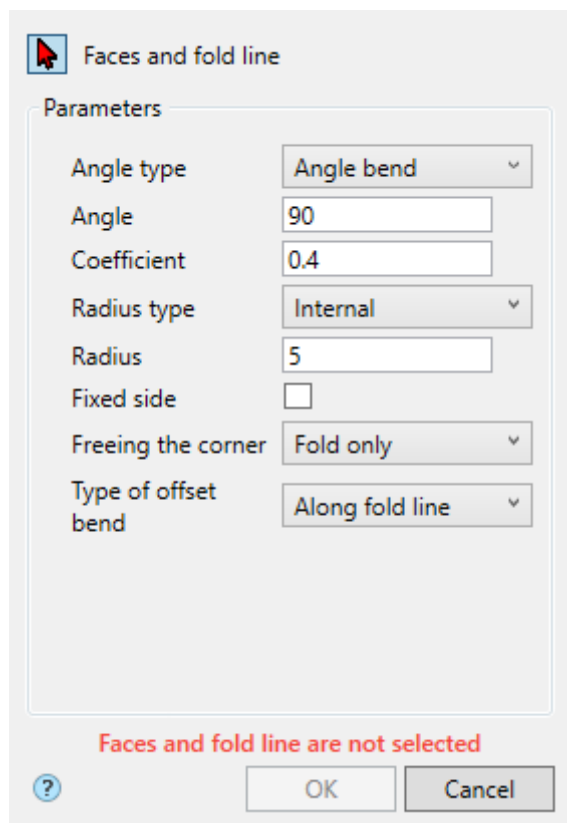

3. Select the face and bend line. Red cursor  means selection mode is on. If faces and bend line are not selected, the corresponding red text "**Faces and fold line are not selected**" is displayed.

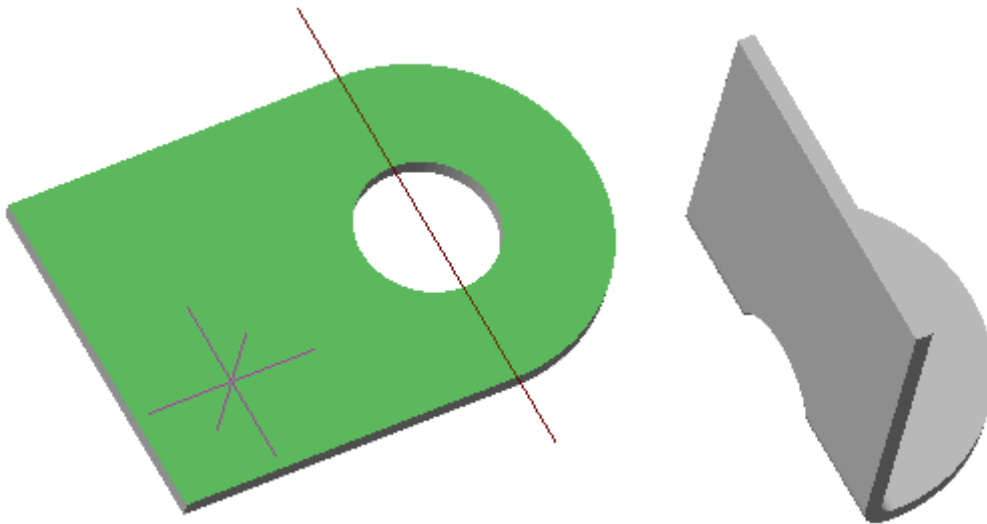

If you need to replace a face (select a different one), re-enter sketch selection mode by clicking the  **"Faces and fold line"** button.

4. Specify the required parameters.

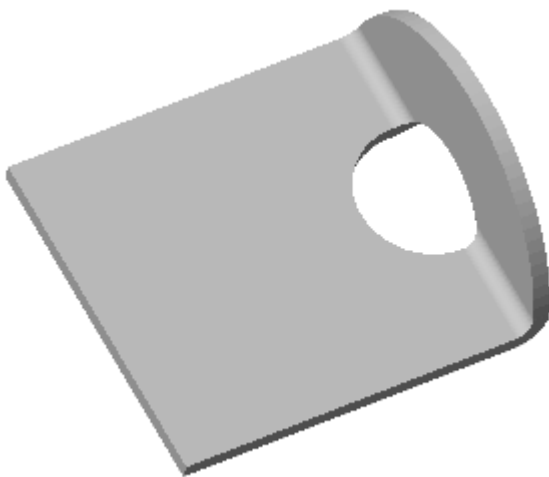

5. Confirm the action with the **"OK"** button. The bend will be constructed. If the **"OK"** button is inactive, it means that no objects were selected or the parameters were set incorrectly. In **"3d History"**, a  **"Bend along line"** object containing the sketch will be created and snapped to an existing or new solid.

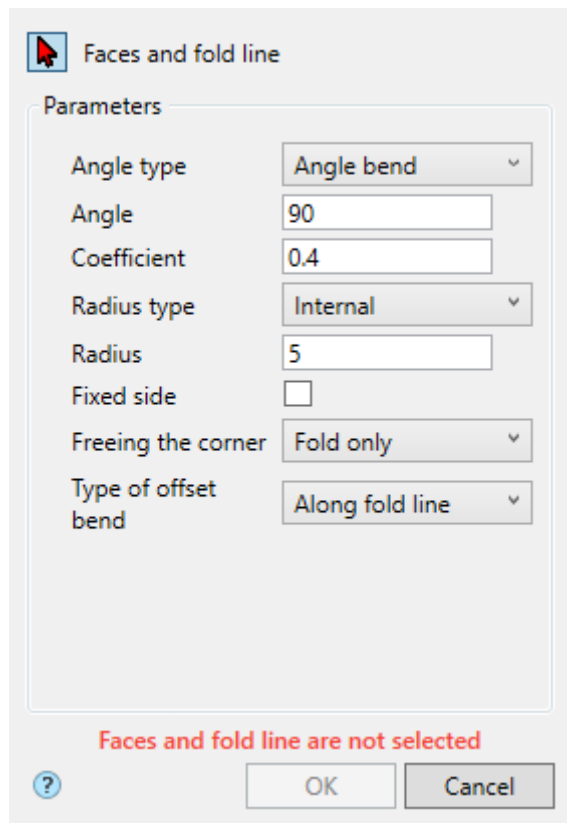

## Dialog



## 3D History

 "Bend along line". As part of the  body.

The following context menu commands are available:

- **Edit** - calls the object for editing. The edit symbol appears to the right of the icon .
- **Rename (F2)** - allows you to rename an object.
- **Delete (Del)** - removes an object from tree and model space.
- **Suppress** - removes an object from model space.
- **Unsuppress** - restores the object in model space.
- **ShowInDocument** - focuses and highlights the subject in the center of model space.
- **Rebuild** - rebuilds an object in model space.

## Jog

### Important!

This functionality requires a C3D 3D modeling engine.



Main menu: **3D - Sheet metal** -  **Jog**.



Ribbon: **3D Tools - Sheet solids** -  **Jog**.



Toolbar: **Sheet metal** -  **Jog**.



Command line: **SMJOG**.

## Procedure

1. Draw a bend line. The line can be a separate primitive or part of a sketch. The bend line must intersect the body completely.

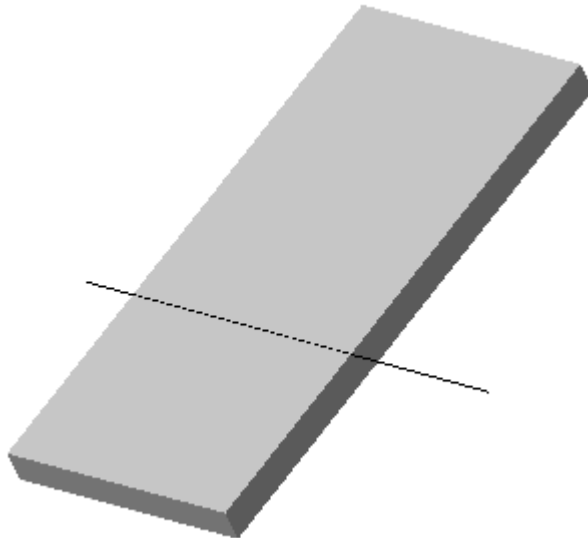

2. Call command  "Jog". The "Jog" dialog will open

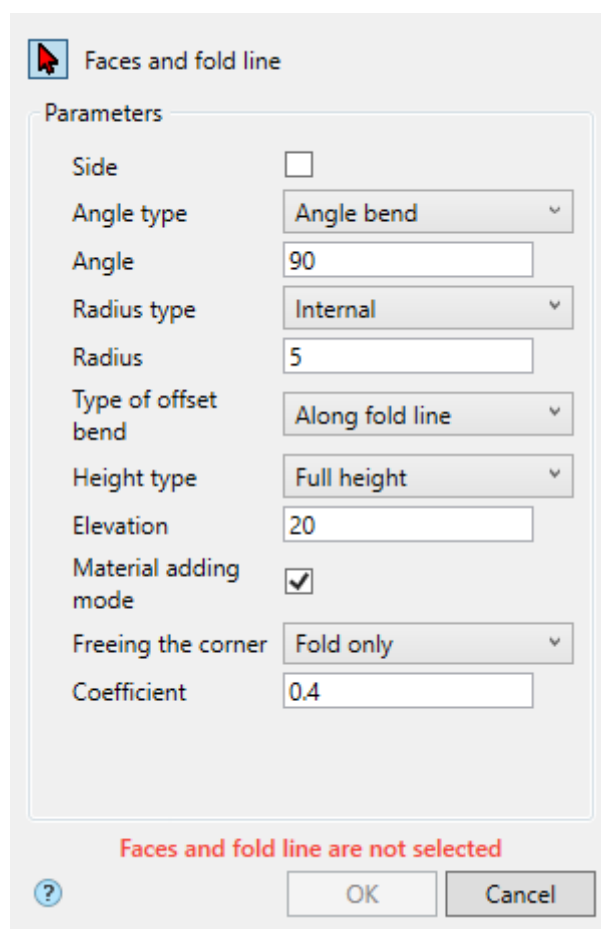

3. Select the face and bend line. Red cursor  means selection mode is on. If faces and bend line are not selected, the corresponding red text "**Faces and fold line are not selected**" is displayed.

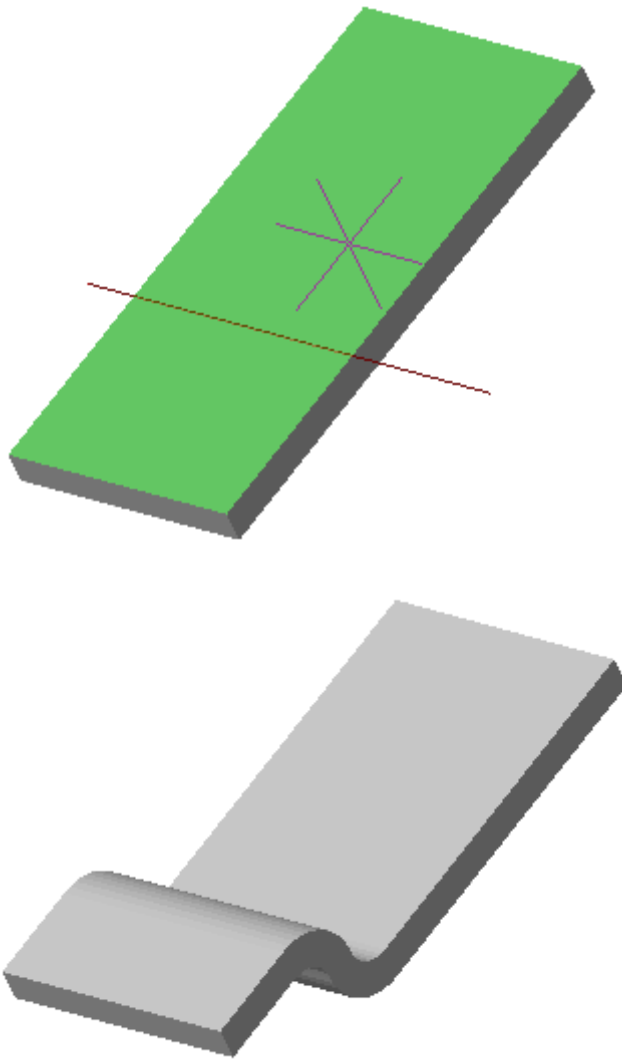

If you need to replace a face (select a different one), re-enter sketch selection mode by clicking the  **"Faces and fold line"** button.

4. Specify the required parameters.

5. Confirm the action with the **"OK"** button. The Jog the line will be constructed. If the **"OK"** button is inactive, it means that no objects were selected or the parameters were set incorrectly. In **"3d History"**, a  **"Jog"** object will be created containing the sketch and will snap to an existing or new body.



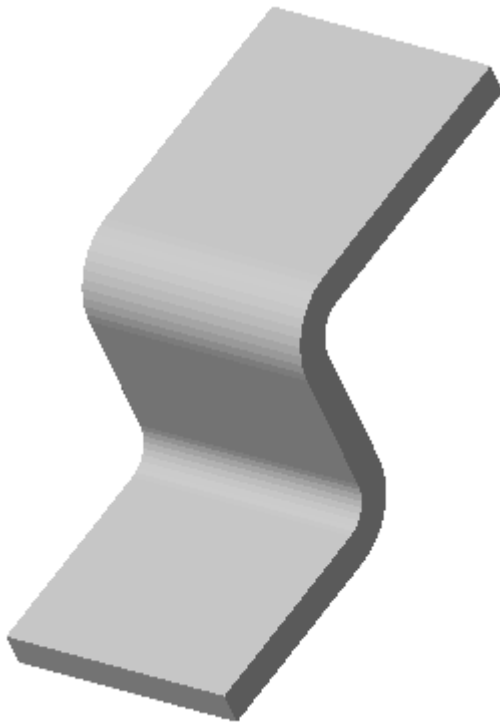

## Dialog

 **Faces and fold line**



Parameters

Side	<input type="checkbox"/>
Angle type	Angle bend ▾
Angle	90
Radius type	Internal ▾
Radius	5
Type of offset bend	Along fold line ▾
Height type	Full height ▾
Elevation	20
Material adding mode	<input checked="" type="checkbox"/>
Freeing the corner	Fold only ▾
Coefficient	0.4

Faces and fold line are not selected

OK
Cancel

## 3D History

 "Jog". As part of the  body.

The following context menu commands are available:

- **Edit** - calls the object for editing. The edit symbol appears to the right of the icon ⚡.
- **Rename (F2)** - allows you to rename an object.
- **Delete (Del)** - removes an object from tree and model space.
- **Suppress** - removes an object from model space.
- **Unsuppress** - restores the object in model space.
- **ShowInDocument** - focuses and highlights the subject in the center of model space.
- **Rebuild** - rebuilds an object in model space.

## Closing corners

### Important!

This functionality requires a C3D 3D modeling engine.



Main menu: **3D - Sheet metal** -  **Closing corners**.



Ribbon: **3D Tools - Sheet solids** -  **Closing corners**.



Toolbar: **Sheet metal** -  **Closing corners**.



Command line: **SMCORNER**.

## Procedure

1. Call command  **"Closing corners"**. The **"Closing corners"** dialog will open.

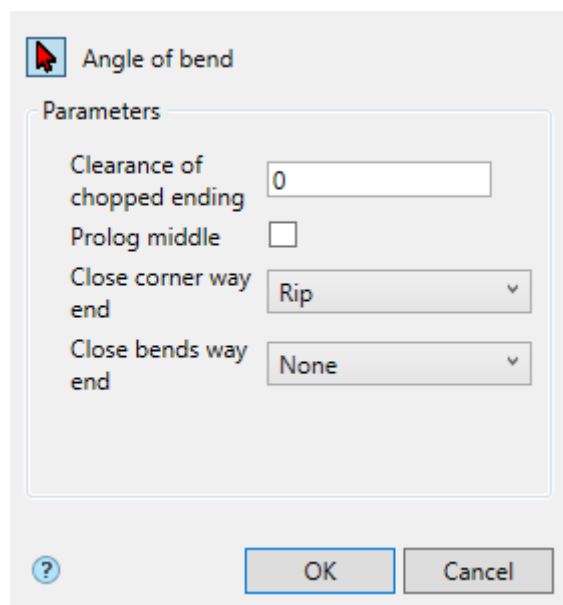

2. Select a bend angle. Red cursor  means selection mode is on.

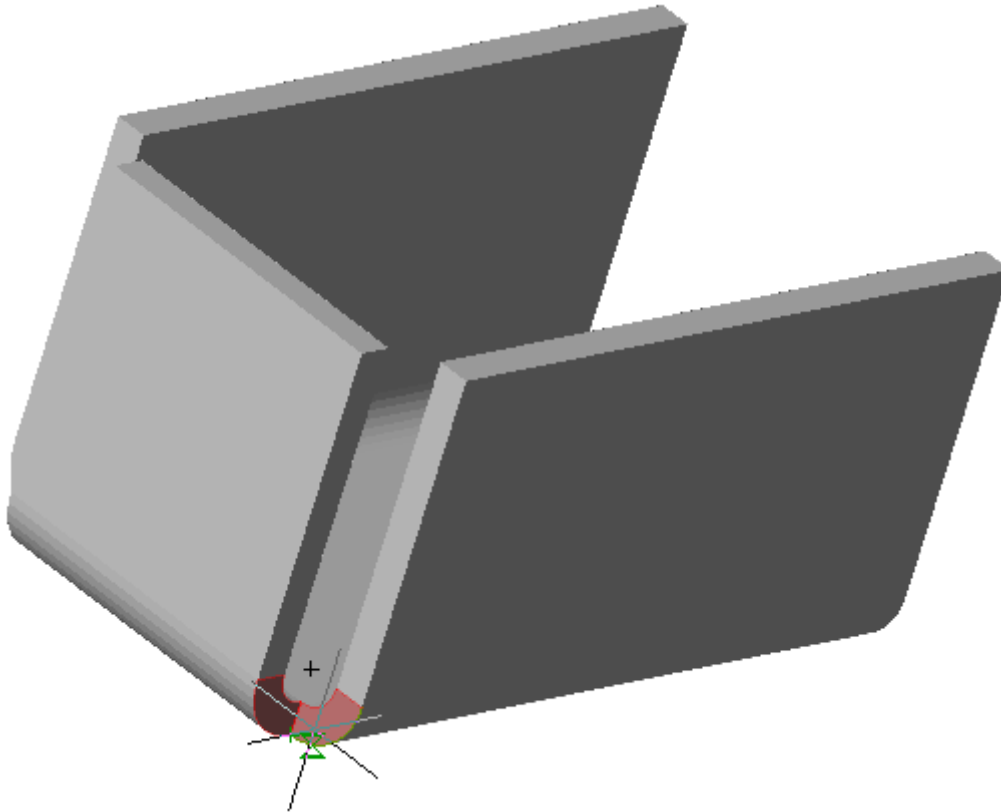

If you need to change the angle (select another), enter the selection mode again by pressing the **"Angle of bend"** button.

3. Specify the required parameters.

Parameters	
Clearance of chopped ending	<input type="text" value="0"/>
Prolog middle	<input type="checkbox"/>
Close corner way end	<input type="text" value="Rip"/>
Close bends way end	<input type="text" value="None"/>

4. Confirm the action with the **"OK"** button. The closing corners will be constructed. If the **"OK"** button is inactive, it means that the corner was not selected or the parameters were set incorrectly. In the **"3d History"** object **"Closing corners"** will be created, with a connection to an existing or new body.

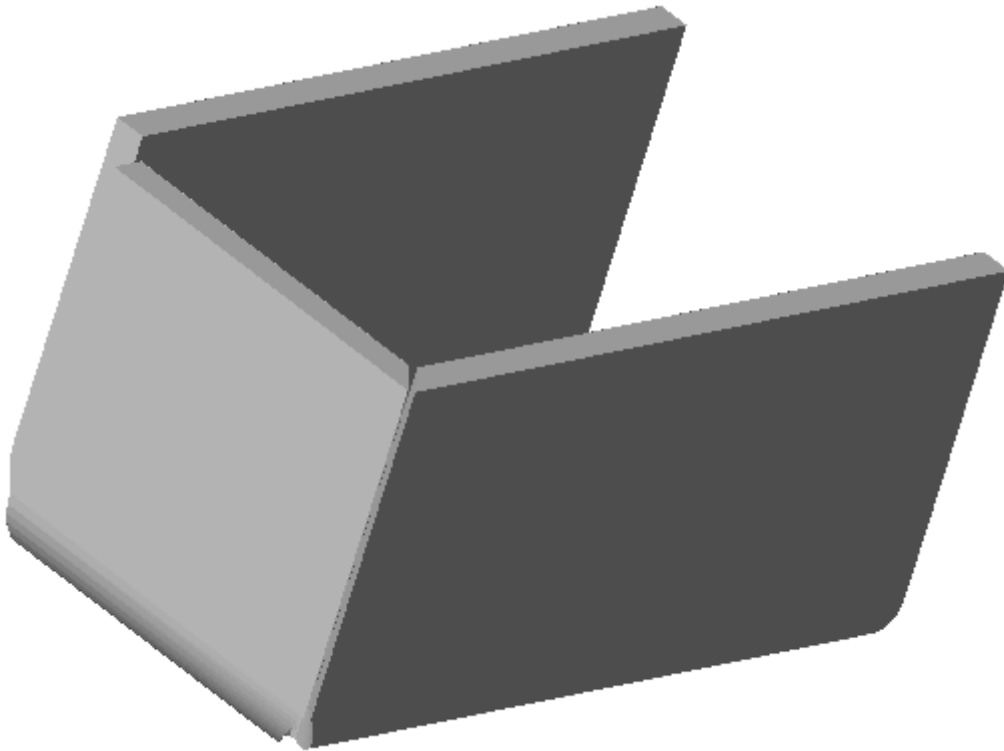

## Dialog

Parameters



Clearance of chopped ending

Prolog middle

Close corner way end

Close bends way end

## 3D History

 "Closing corners". As part of the  body.

The following context menu commands are available:

- **Edit** - calls the object for editing. The edit symbol appears to the right of the icon .
- **Rename (F2)** - allows you to rename an object.
- **Delete (Del)** - removes an object from tree and model space.
- **Suppress** - removes an object from model space.
- **Unsuppress** - restores the object in model space.
- **ShowInDocument** - focuses and highlights the subject in the center of model space.
- **Rebuild** - rebuilds an object in model space.

## Hole

**Important!** This functionality requires a C3D 3D modeling engine.

 Main menu: **3D - Sheet metal - Hole**.

 Ribbon: **3D Tools - Sheet solids - Hole**.

 Toolbar: **Sheet metal - Hole**.

 Command line: **SMHOLE**.

### Procedure

1. Draw a closed sketch on one of the faces of the sheet solid.

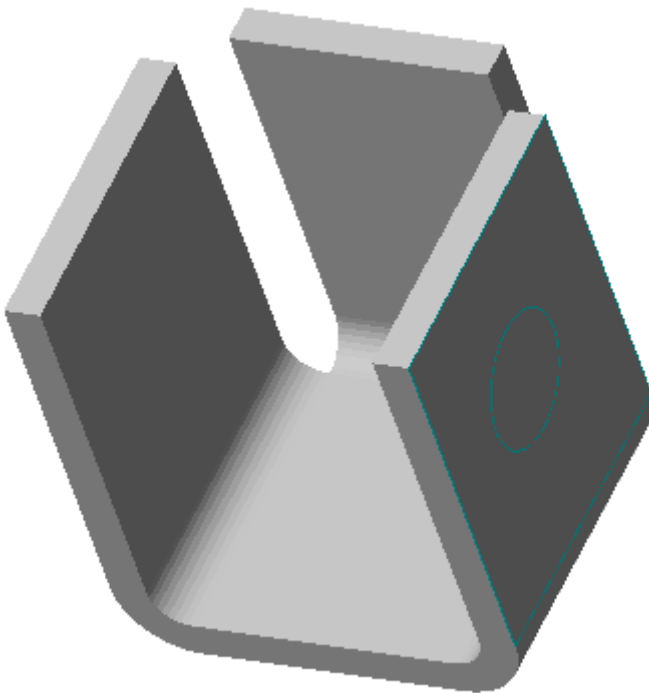

2. Call command  **"Hole"**. The **"Hole"** dialog will open.

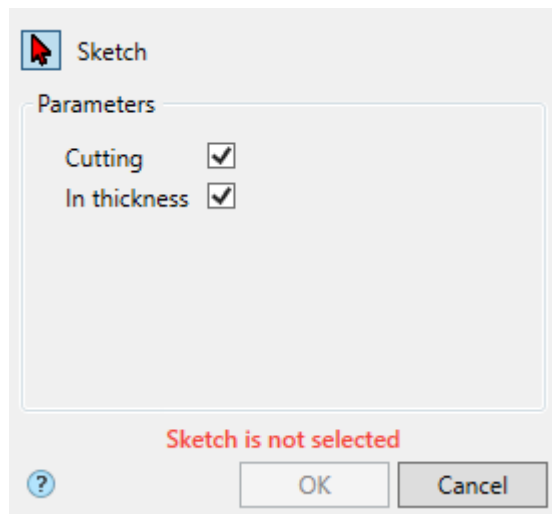

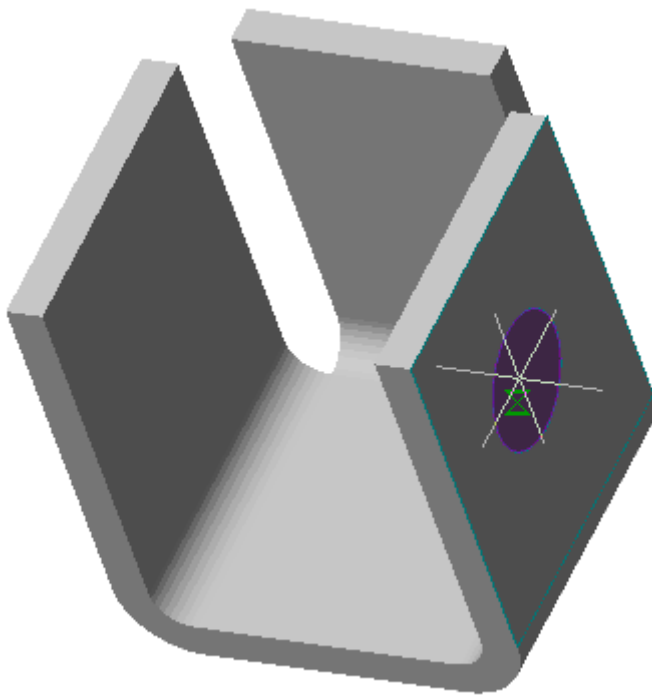

3. Select a sketch. A red cursor  means that the sketch selection mode is on. If a sketch is not selected, the corresponding red **"Sketch is not selected"** is displayed.

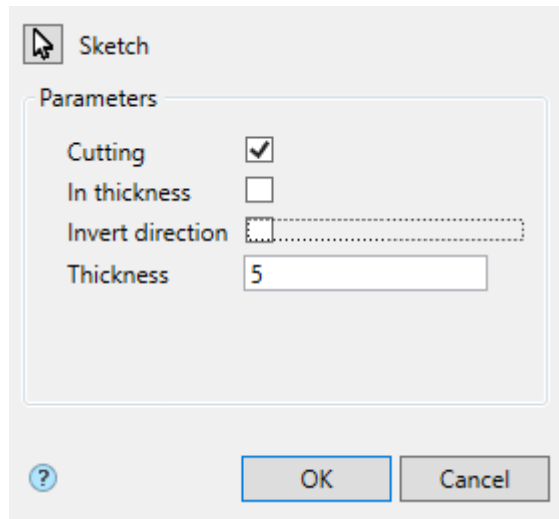

If you need to replace the sketch (select another), re-enter the sketch selection mode by clicking the  **"Sketch"** button.

4. Specify the required parameters.



5. Confirm the action with the **"OK"** button. The hole will be built. If the **"OK"** button is grayed out, it means that the sketch was not selected or the parameters were set incorrectly. In **"3d History"**, a  **"Hole"** object containing a sketch will be created and snapped to an existing or new solid.

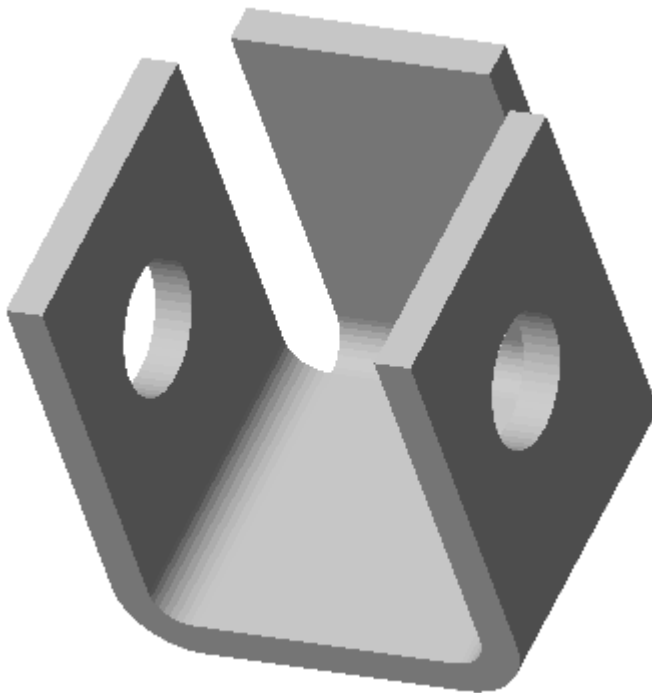

## Dialog

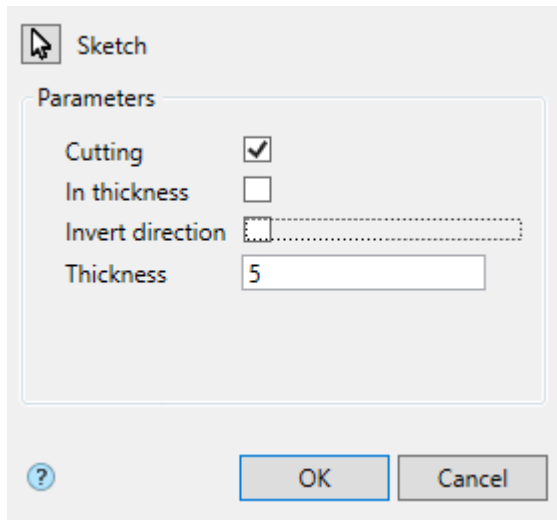

Button  "**Sketch**" - turns on the sketch selection mode in the drawing.

Switch "**Cutting**" - defines the clipping area. When the switch is on, the area inside the sketch is cut out, when it is off - outside.

Switch "**In thickness**" - defines the depth of the cut. When the switch is on, the cut is made to the thickness of the sheet, when it is off, it is set independently.

Switch "**Invert direction**" - changes the direction of the cut.

Field "**Thickness**" - depth of cut, the field is active when the "In thickness" switch is off.

## 3D History

 "**Hole**". As part of the  body.

The following context menu commands are available:

- **Edit** - calls the object for editing. The edit symbol appears to the right of the icon .
- **Rename (F2)** - allows you to rename an object.
- **Delete (Del)** - removes an object from tree and model space.
- **Suppress** - removes an object from model space.
- **Unsuppress** - restores the object in model space.
- **ShowInDocument** - focuses and highlights the subject in the center of model space.
- **Rebuild** - rebuilds an object in model space.

## Unbend

### Important!

This functionality requires a C3D 3D modeling engine.



Main menu: **3D - Sheet metal -  Unbend.**



Ribbon: **3D Tools - Sheet solids -  Unbend.**



Toolbar: **Sheet metal -  Unbend.**





 Command line: **SMUNBEND**.

The command allows you to unbend sections of a sheet body.

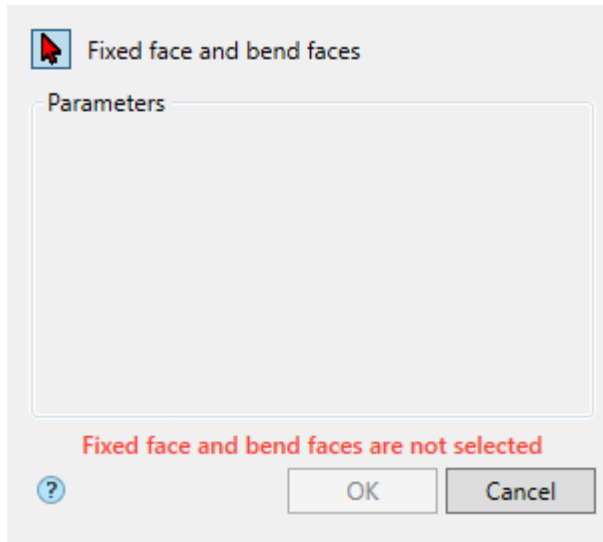

### *Procedure*

1. Call command  **"Unbend"**. The **"Unbend"** dialog will open.

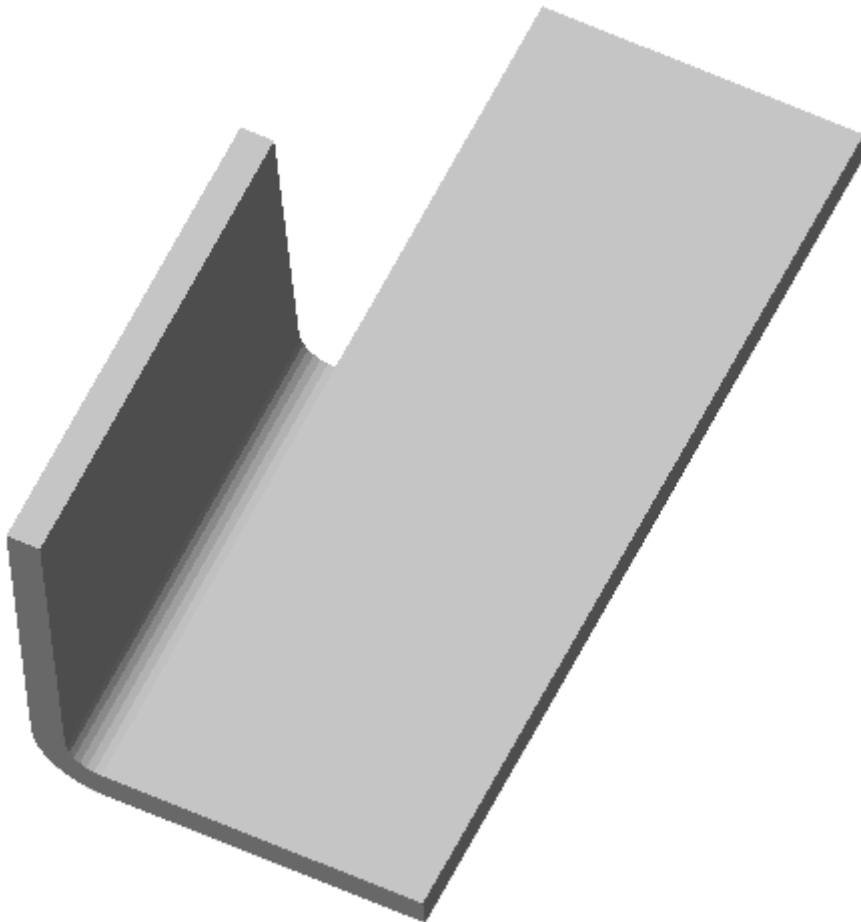
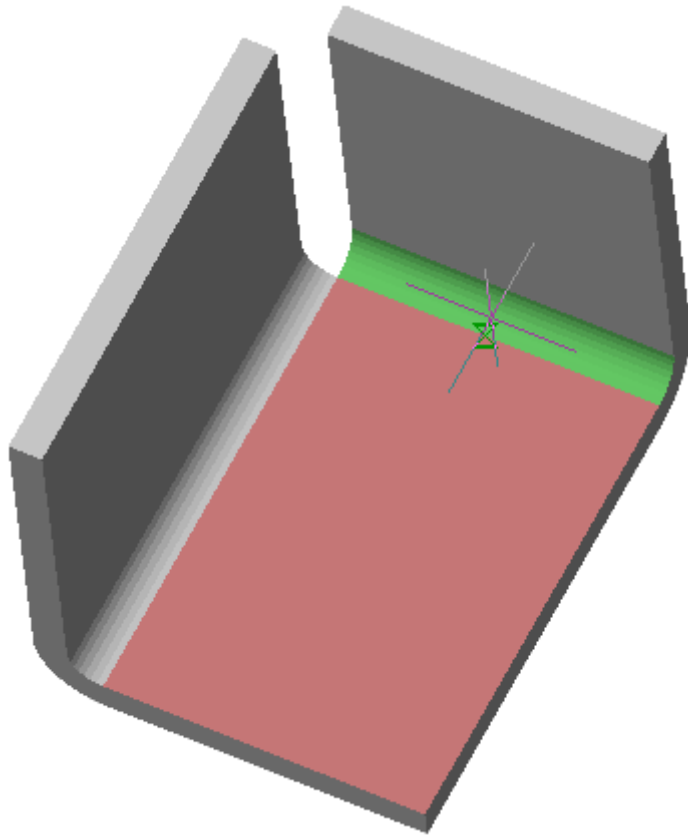

2. Select the face in the plane of which the bend will be performed and the bend adjacent to the face. Red cursor  means selection mode is on. If no faces are selected, the corresponding red **"Fixed face and bend faces are not selected"** text is displayed.



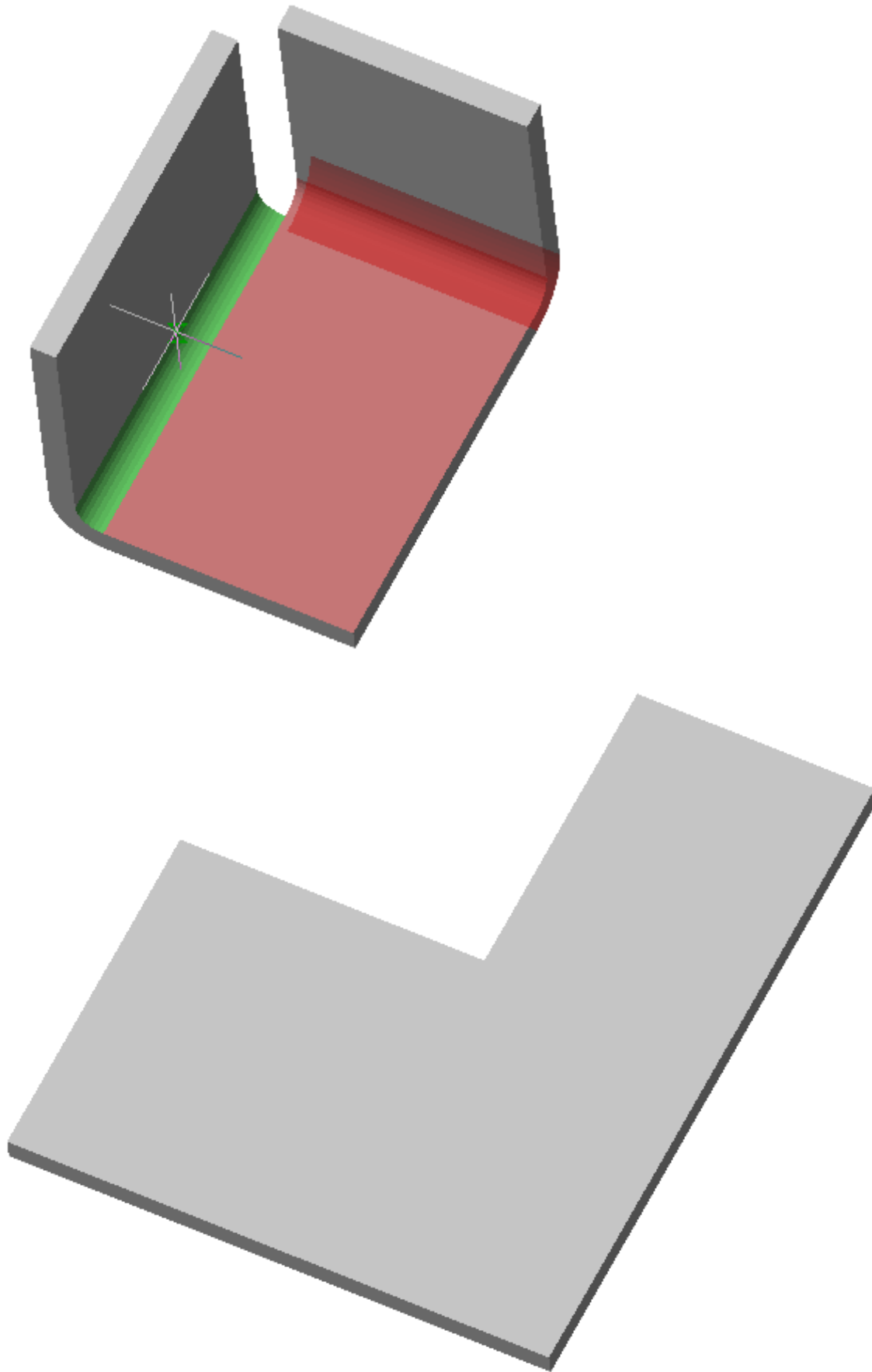

If you need to replace a face or add faces, re-enter selection mode by pressing the  **"Fixed face and bend faces"** button. To confirm your choice, click on .



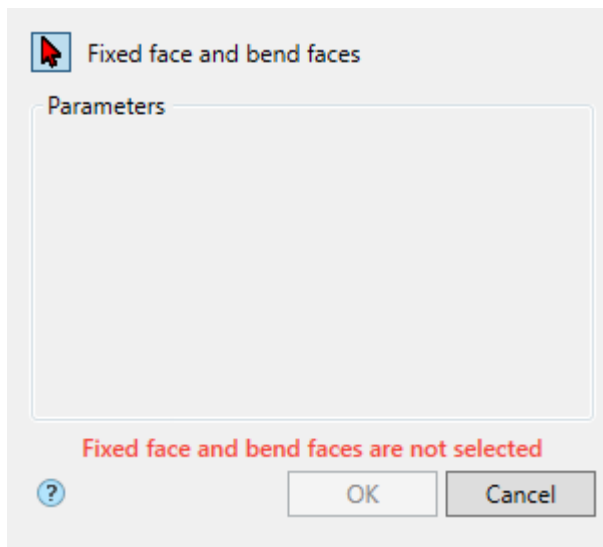

3. Confirm the action with the **"OK"** button. The sheet solid will be unbent. If the **"OK"** button is grayed out, then no faces were selected. An  **"Unbend"** object will be created in the **"3d History"**, with a connection to an existing or new body.

## Dialog



Button  "**Fixed face and bend faces**" - turns on the face selection mode in the drawing.

## 3D History

 "**Unbend**". As part of the  body.

The following context menu commands are available:

- **Edit** - calls the object for editing. The edit symbol appears to the right of the icon .
- **Rename (F2)** - allows you to rename an object.
- **Delete (Del)** - removes an object from tree and model space.
- **Suppress** - removes an object from model space.
- **Unsuppress** - restores the object in model space.
- **ShowInDocument** - focuses and highlights the subject in the center of model space.
- **Rebuild** - rebuilds an object in model space.

## Bend

**Important!** This functionality requires a C3D 3D modeling engine.

 Main menu: **3D - Sheet metal -  Bend**.

 Ribbon: **3D Tools - Sheet solids -  Bend**.

 Toolbar: **Sheet metal -  Bend**.

 Command line: **SMBEND**.

The command allows you to bend previously unfolded sections of a sheet body.

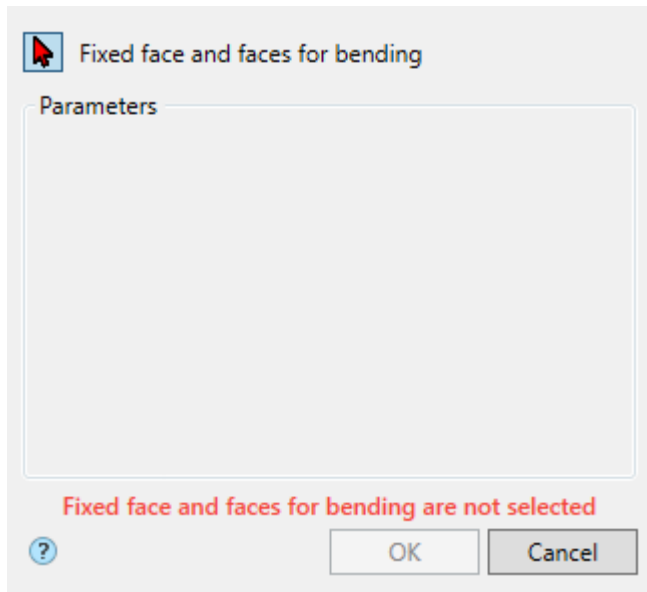

## Procedure

1. Call command  "**Bend**". The "**Bend**" dialog will open.

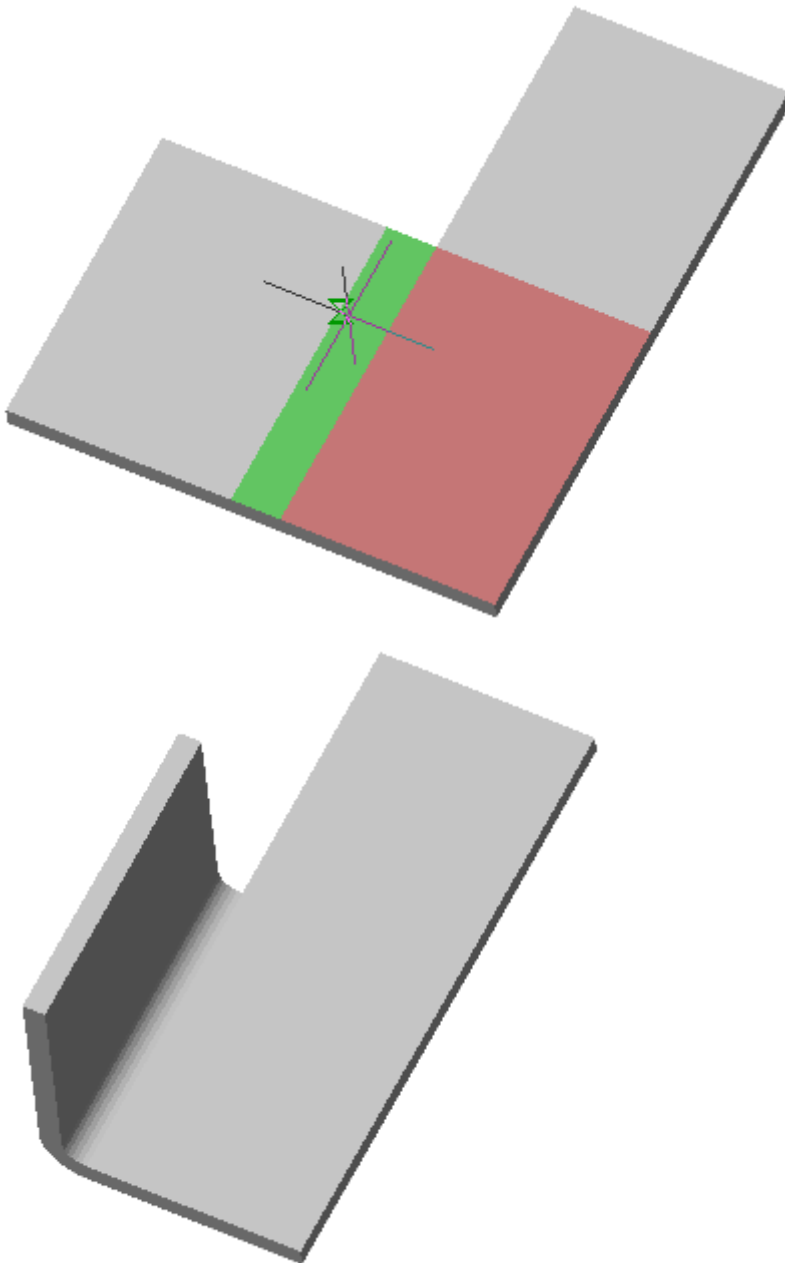

2. Select the main face to bend in the plane and the adjacent face (bend). Red cursor  means selection mode is on. If no faces are selected, the corresponding red **"Fixed face and faces for bending are not selected"** text is displayed.



If you need to replace a face or add faces, re-enter selection mode by pressing the  **"Fixed face and faces for bending"** button. To confirm your choice, click on .

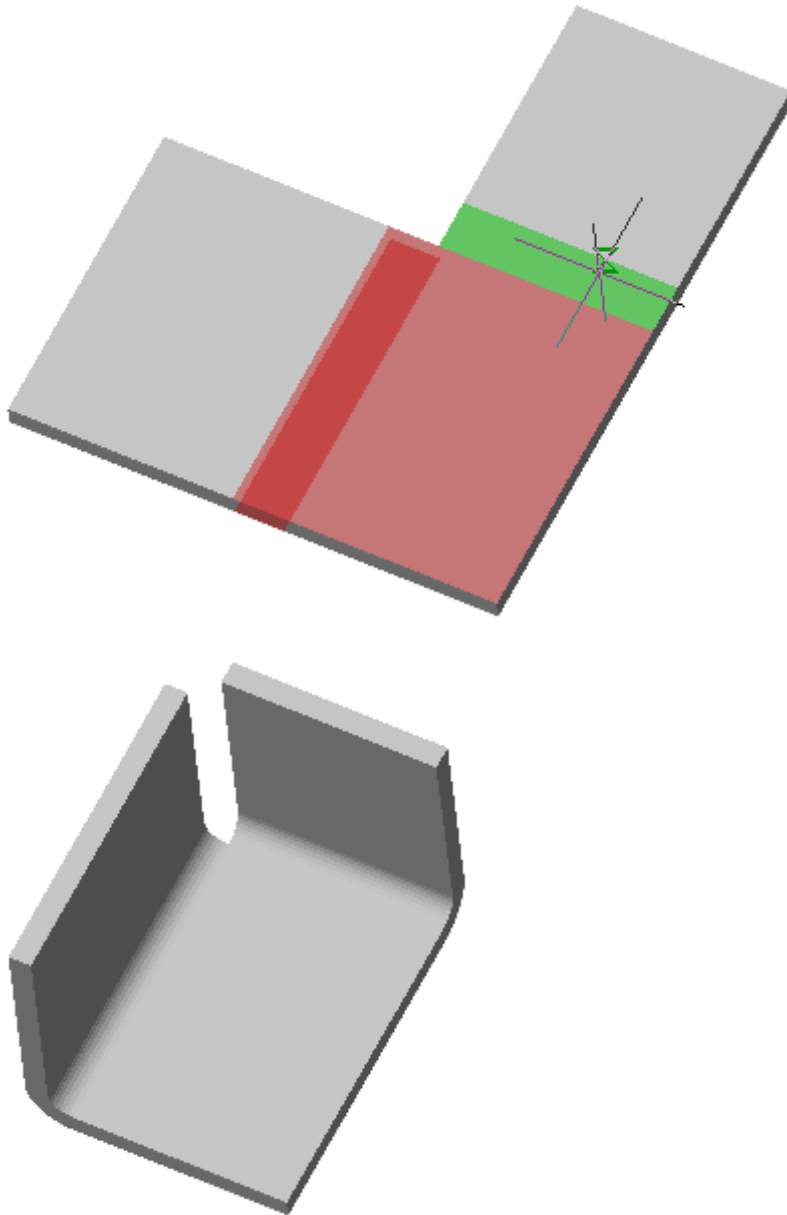

3. Confirm the action with the **"OK"** button. The sheet solid will be bent. If the **"OK"** button is grayed out, then no faces were selected. A  **"Bend"** object will be created in the **"3d History"**, with a snap to an existing or new body.

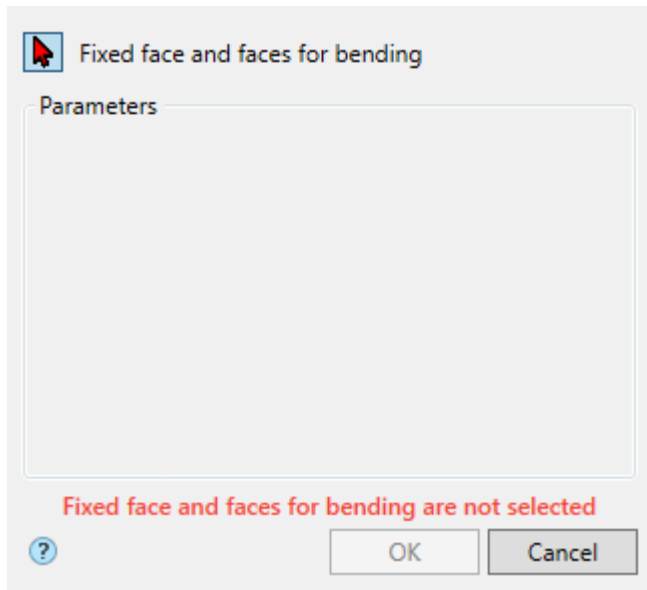

Button  "**Fixed face and faces for bending**" - turns on the face selection mode in the drawing.

### 3D History

 "**Bend**". As part of the  body.

The following context menu commands are available:

- **Edit** - calls the object for editing. The edit symbol appears to the right of the icon .
- **Rename (F2)** - allows you to rename an object.
- **Delete (Del)** - removes an object from tree and model space.
- **Suppress** - removes an object from model space.
- **Unsuppress** - restores the object in model space.
- **ShowInDocument** - focuses and highlights the subject in the center of model space.
- **Rebuild** - rebuilds an object in model space.

## Flatten

**Important!** This functionality requires a C3D 3D modeling engine.

 Main menu: **3D - Sheet metal -  Flatten.**

 Ribbon: **3D Tools - Sheet solids -  Flatten.**

 Toolbar: **Sheet metal -  Flatten.**

 Command line: **SMFLATTEN.**

The command allows you to create a flat pattern of a sheet body.

### Procedure

1. Call command  "**Flatten**". The "**Flatten**" dialog will open.



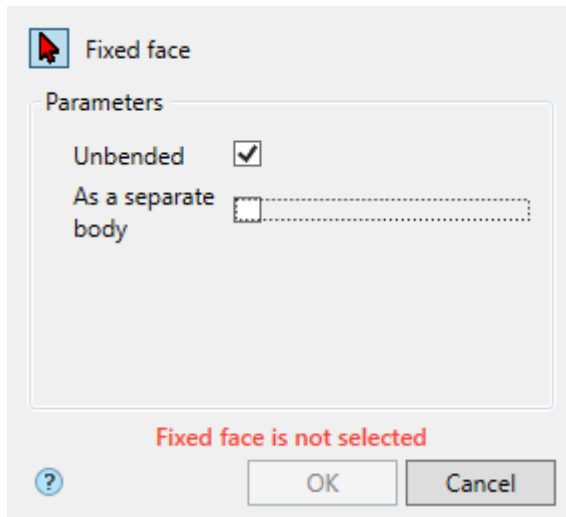

2. Select the face to unfold relative to. Red cursor  means selection mode is on. If no face is selected, the corresponding red text **"Fixed face is not selected"** is displayed.

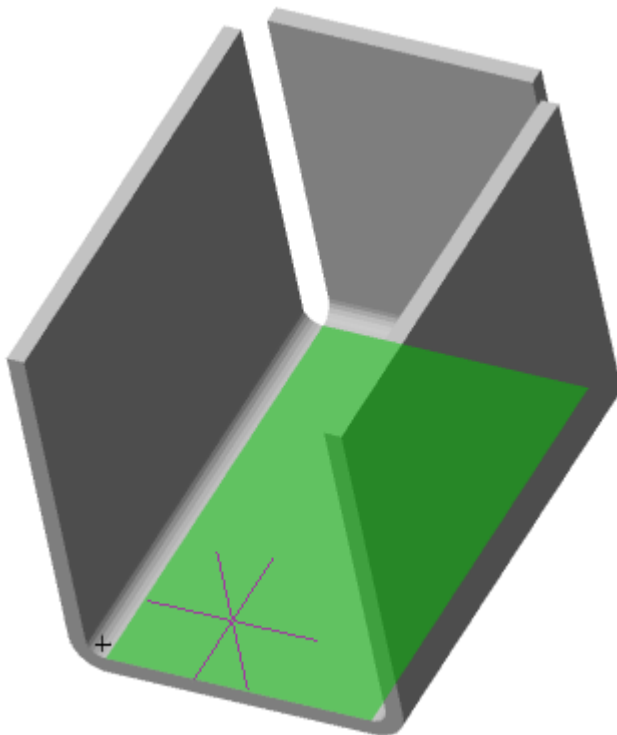

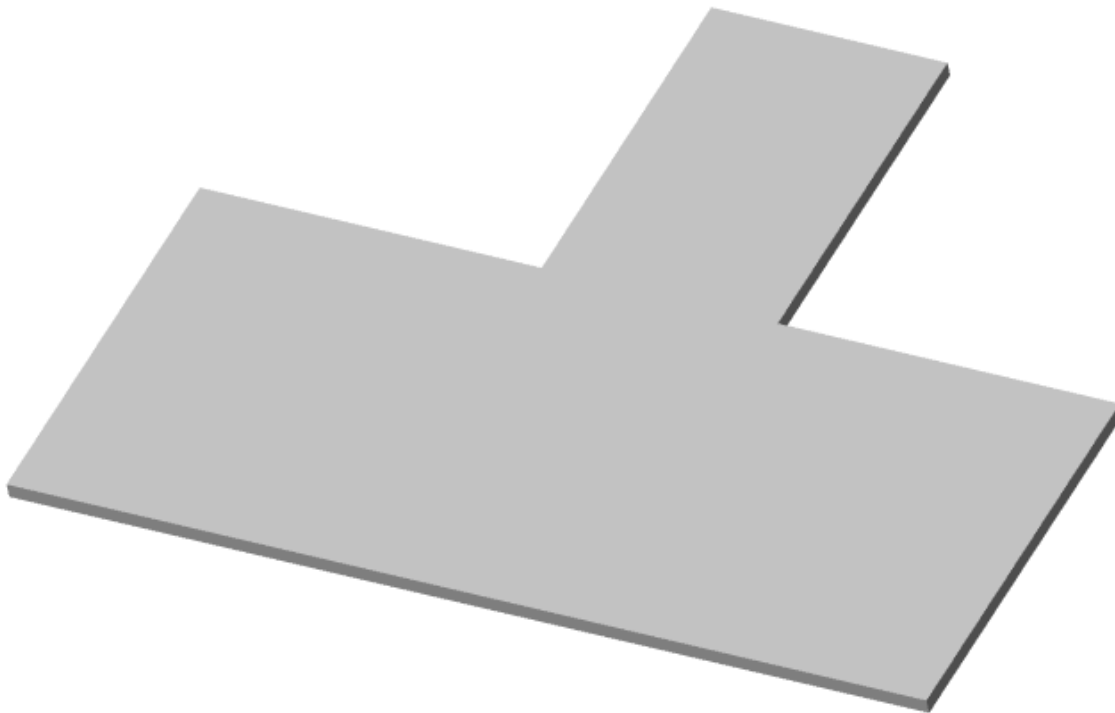

If you need to replace a face, re-enter selection mode by pressing the  **"Fixed face"** button.

3. Confirm the action with the **"OK"** button. The flatten will be built. If the **"OK"** button is grayed out, then no face has been selected. In the **"3d History"** object  **"Flatten"** will be created, with reference to an existing or new body.

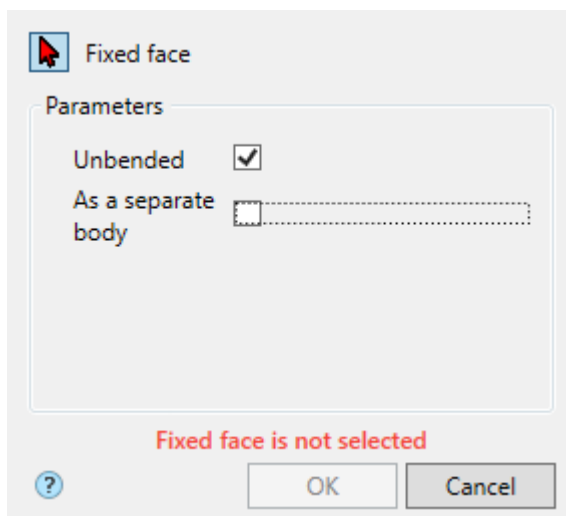

## Dialog





Button  **"Fixed face"** - turns on the face selection mode in the drawing.

Switch **"Unbended"** - controls the sweep state.

Switch **"As a separate body"** - creates a separate body.

## 3D History

 **"Flatten"**. As part of the  body.

The following context menu commands are available:

- **Edit** - calls the object for editing. The edit symbol appears to the right of the icon .
- **Rename (F2)** - allows you to rename an object.
- **Delete (Del)** - removes an object from tree and model space.
- **Suppress** - removes an object from model space.

- **Unsuppress** - restores the object in model space.
- **ShowInDocument** - focuses and highlights the subject in the center of model space.
- **Rebuild** - rebuilds an object in model space.

## Stamp

**Important!** This functionality requires a C3D 3D modeling engine.

 Main menu: **3D - Sheet metal - Stamp**.

 Ribbon: **3D Tools - Sheet solids - Stamp**.

 Toolbar: **Sheet metal - Stamp**.

 Command line: **SMSTAMP**.

### Procedure

1. Draw a closed sketch on the face of the sheet body.

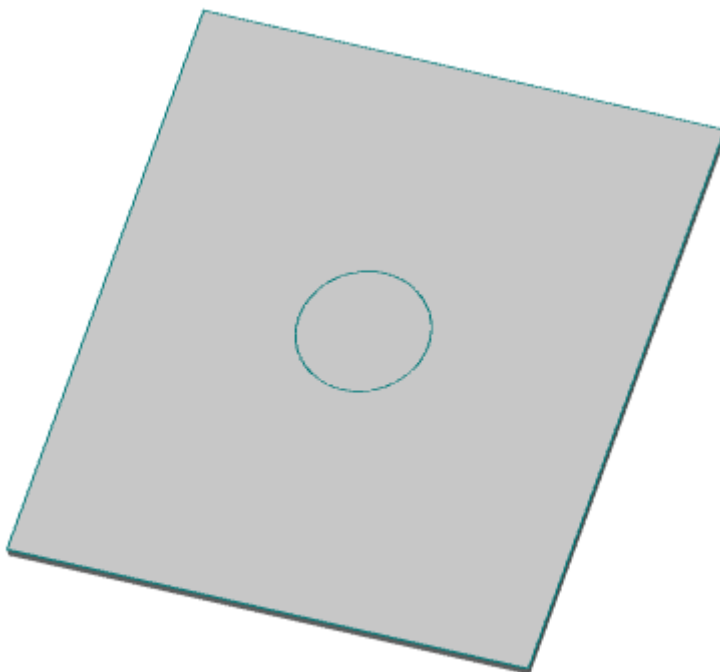

2. Call command **Stamp**. The **Stamp** dialog will open.

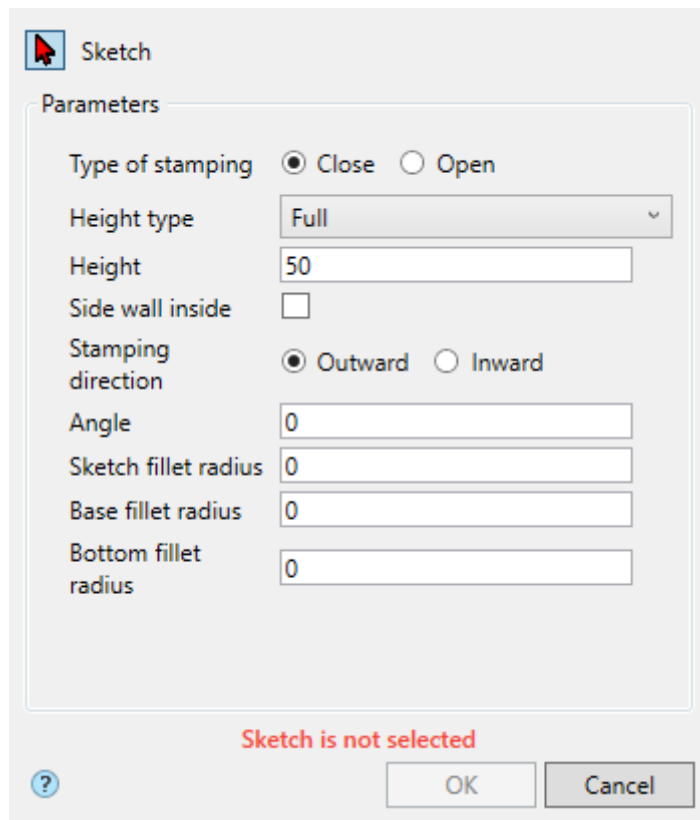

3. Select a sketch. A red cursor  means that the sketch selection mode is on. If a sketch is not selected, the corresponding red **"Sketch is not selected"** is displayed.

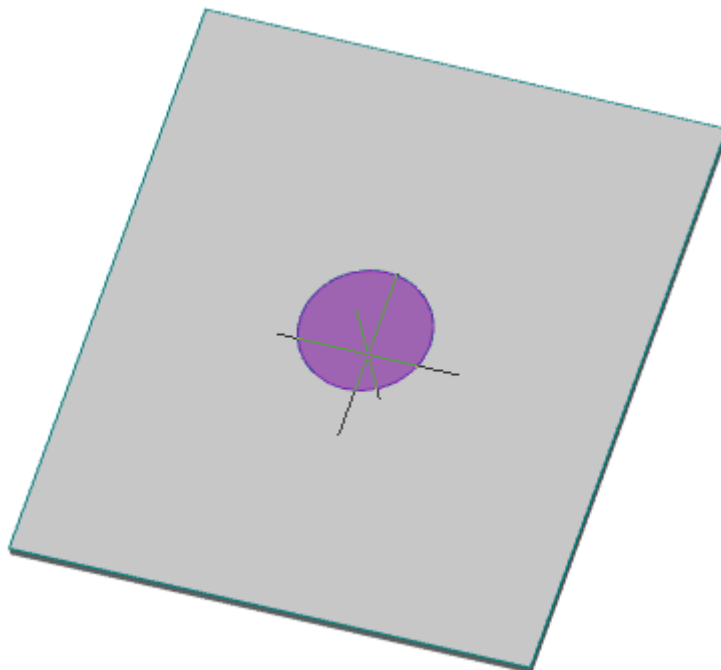

If you need to replace the sketch (select another), re-enter the sketch selection mode by clicking the  **"Sketch"** button.

4. Specify the required parameters.

5. Confirm the action with the **"OK"** button. The stamp will be created. If the **"OK"** button is grayed out, it means that the sketch was not selected or the parameters were set incorrectly. In

"3d History", a  "Stamp" object containing the sketch will be created and snapped to an existing or new solid.

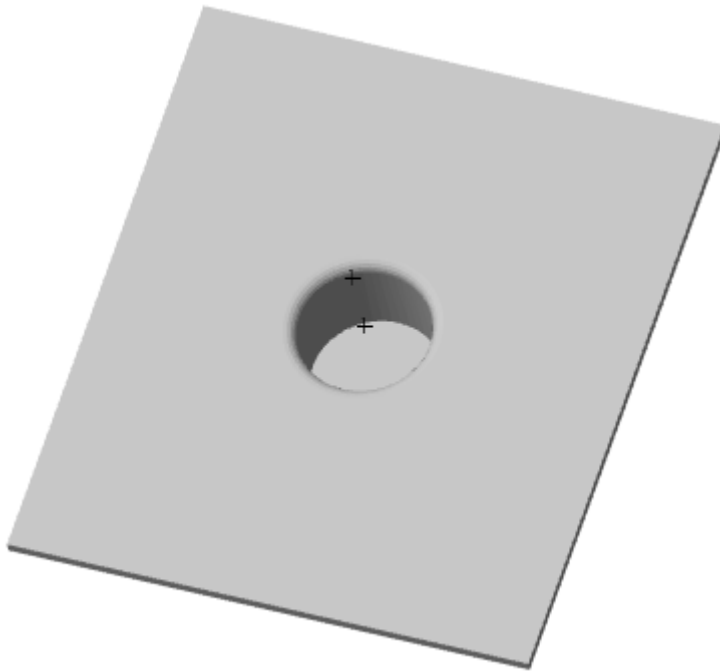

### Dialog

Sketch

Parameters

Type of stamping     Close     Open

Height type            Full ▼

Height                 50

Side wall inside      

Stamping direction     Outward     Inward

Angle                    0

Sketch fillet radius    0



Base fillet radius      0

Bottom fillet radius   0

Sketch is not selected

?
OK
Cancel

### 3D History

 "Stamp". As part of the  body.

The following context menu commands are available:

- **Edit** - calls the object for editing. The edit symbol appears to the right of the icon ⚡.
- **Rename (F2)** - allows you to rename an object.
- **Delete (Del)** - removes an object from tree and model space.
- **Suppress** - removes an object from model space.
- **Unsuppress** - restores the object in model space.
- **ShowInDocument** - focuses and highlights the subject in the center of model space.
- **Rebuild** - rebuilds an object in model space.

## Jalousie

**Important!** This functionality requires a C3D 3D modeling engine.

 Main menu: **3D - Sheet metal - Jalousie**.

 Ribbon: **3D Tools - Sheet solids - Jalousie**.

 Toolbar: **Sheet metal - Jalousie**.

 Command line: **SMJALOUSIE**.

### Procedure

1. Sketch on the face of the sheet body. Lines are used as sketches for the punch. The sketch must be completely within the base face of the feature.

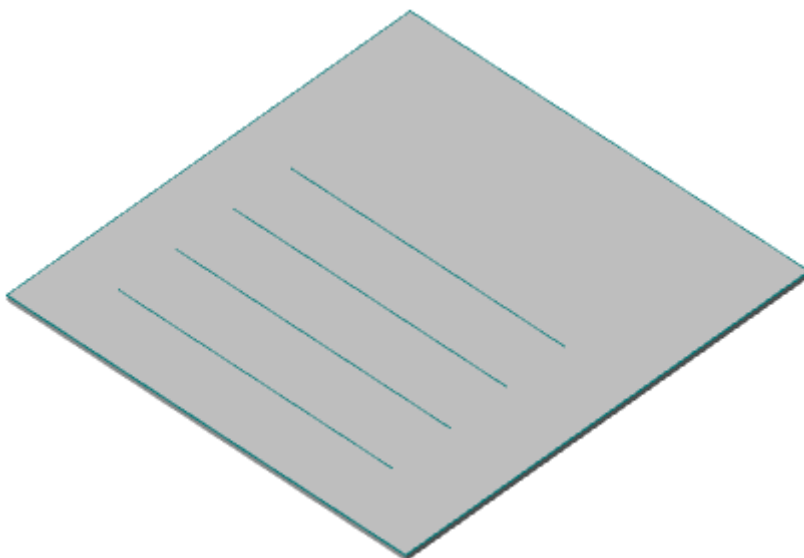

2. Call command **Jalousie**. The "Jalousie" dialog will open.

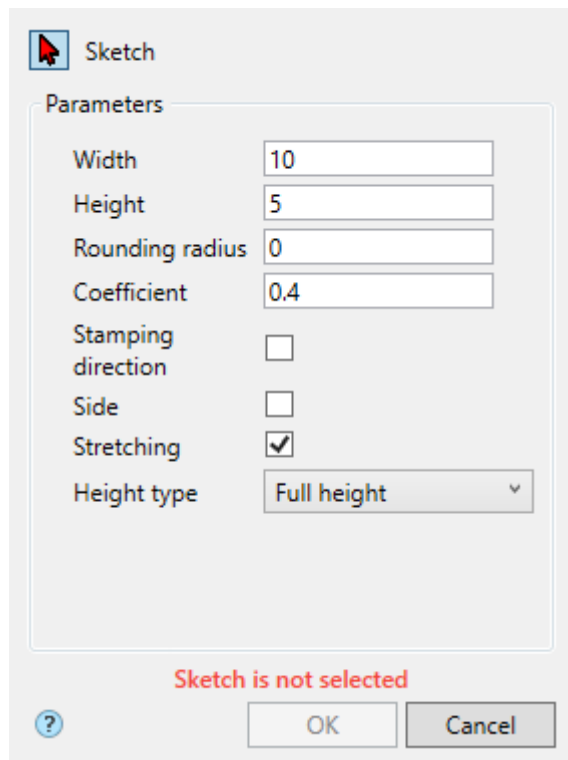

3. Select a sketch. A red cursor  means that the sketch selection mode is on. If a sketch is not selected, the corresponding red **"Sketch is not selected"** is displayed.

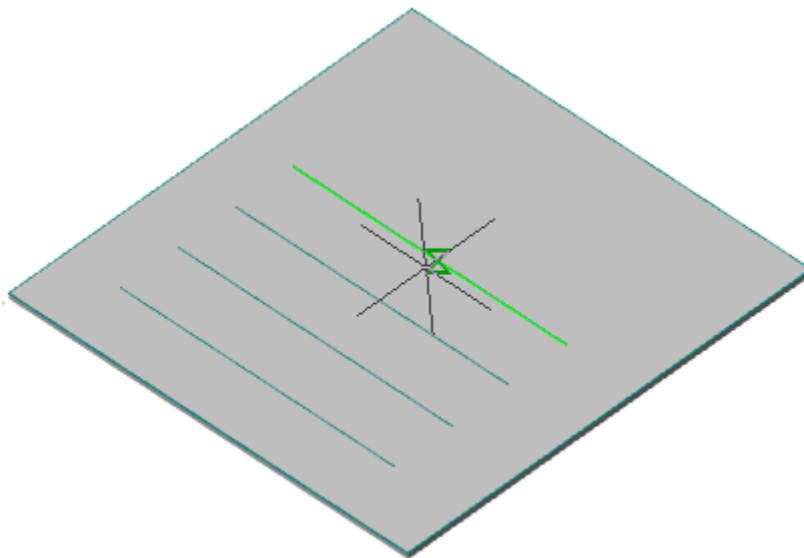

If you need to replace the sketch (select another), re-enter the sketch selection mode by clicking the  **"Sketch"** button.

4. Specify the required parameters.

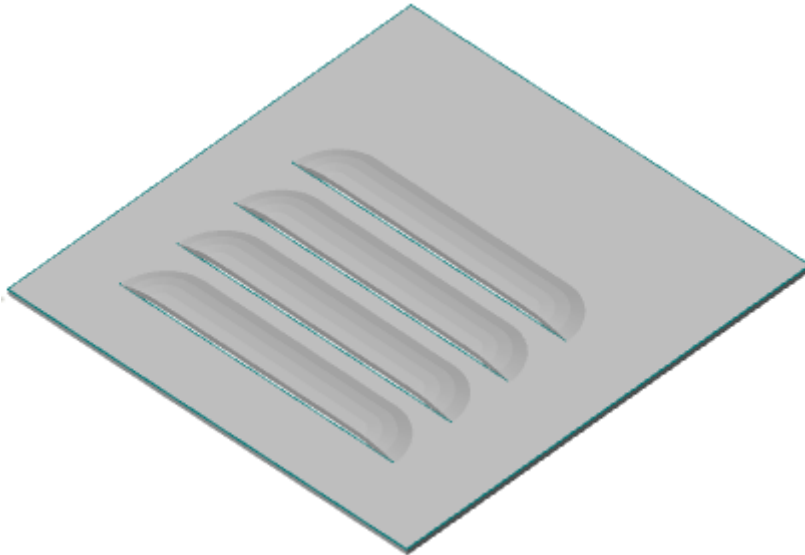

5. Confirm the action with the **"OK"** button. The punch will be created. If the **"OK"** button is grayed out, it means that the sketch was not selected or the parameters were set incorrectly. If the preview does not show the punch, then the parameters are incorrect. In **"3d History"**, a  **"Jalousie"** object containing a sketch is created and snapped to an existing or new solid.

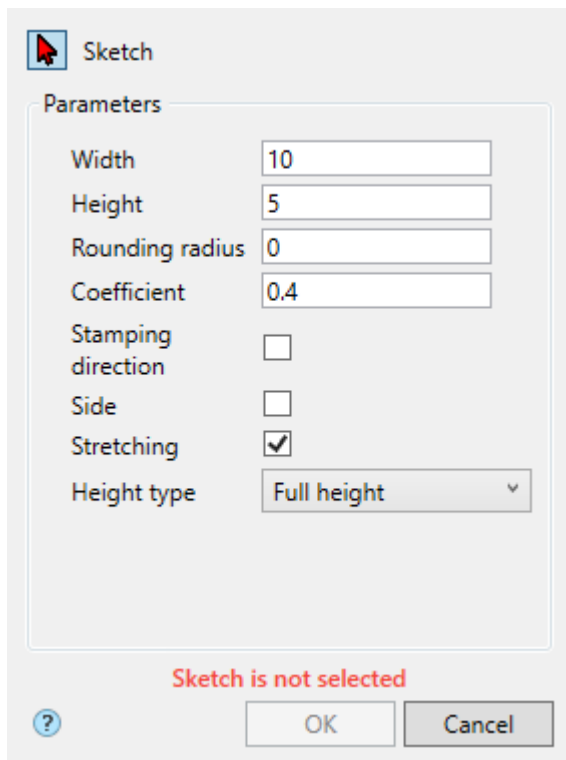

### Dialog



### 3D History

 "Jalousie". As part of the  body.

The following context menu commands are available:

- **Edit** - calls the object for editing. The edit symbol appears to the right of the icon .
- **Rename (F2)** - allows you to rename an object.
- **Delete (Del)** - removes an object from tree and model space.
- **Suppress** - removes an object from model space.
- **Unsuppress** - restores the object in model space.
- **ShowInDocument** - focuses and highlights the subject in the center of model space.
- **Rebuild** - rebuilds an object in model space.



## Bead

**Important!** This functionality requires a C3D 3D modeling engine.

 Main menu: **3D - Sheet metal - Bead**.

 Ribbon: **3D Tools - Sheet solids - Bead**.

 Toolbar: **Sheet metal - Bead**.

 Command line: **SMBEAD**.

### Procedure

1. Sketch on the face of the sheet body. A sketch can contain multiple primitives.

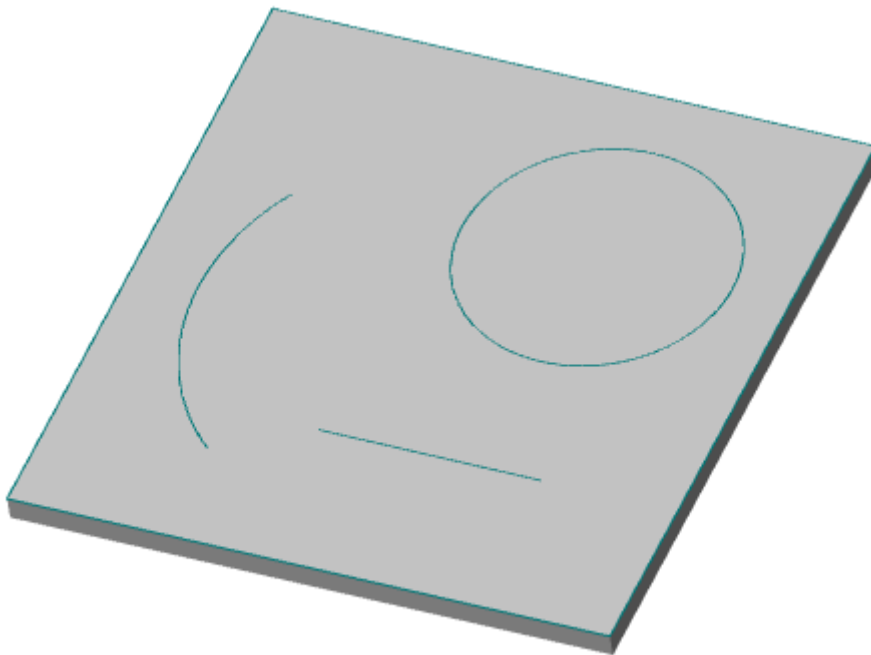

2. Call command **"Bead"**. The **"Bead"** dialog will open.

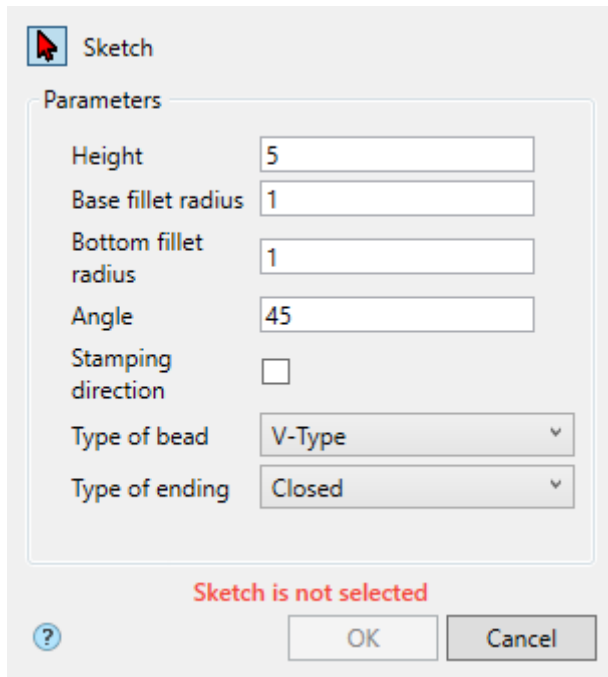

3. Select a sketch. A red cursor  means that the sketch selection mode is on. If a sketch is not selected, the corresponding red **"Sketch is not selected"** is displayed.

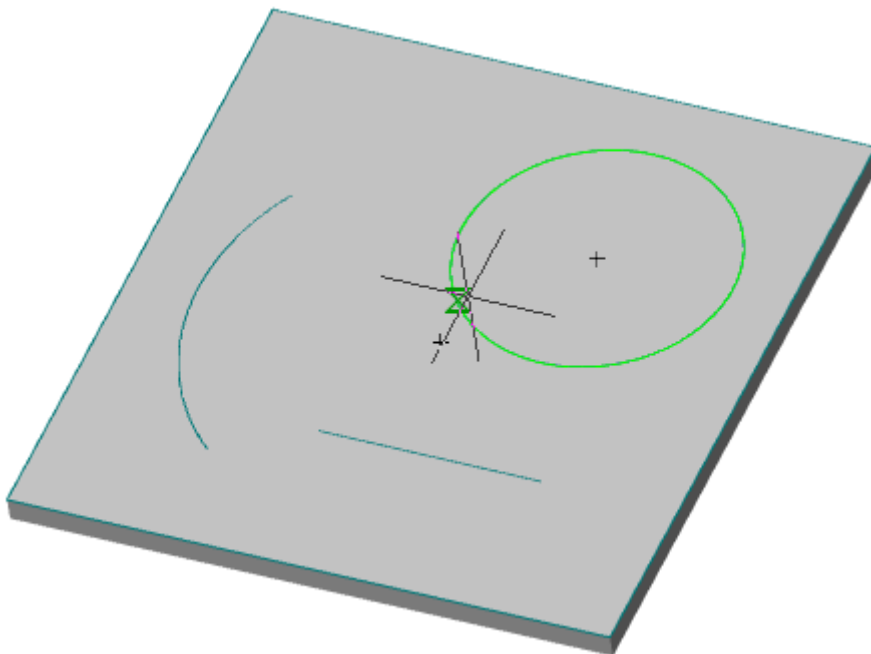

If you need to replace the sketch (select another), re-enter the sketch selection mode by clicking the  **"Sketch"** button.

4. Specify the required parameters.

5. Confirm the action with the **"OK"** button. The bend will be created. If the **"OK"** button is grayed out, it means that the sketch was not selected or the parameters were set incorrectly. In **"3d History"**, a  **"Bead"** object containing a sketch will be created and referenced to an existing or new solid.

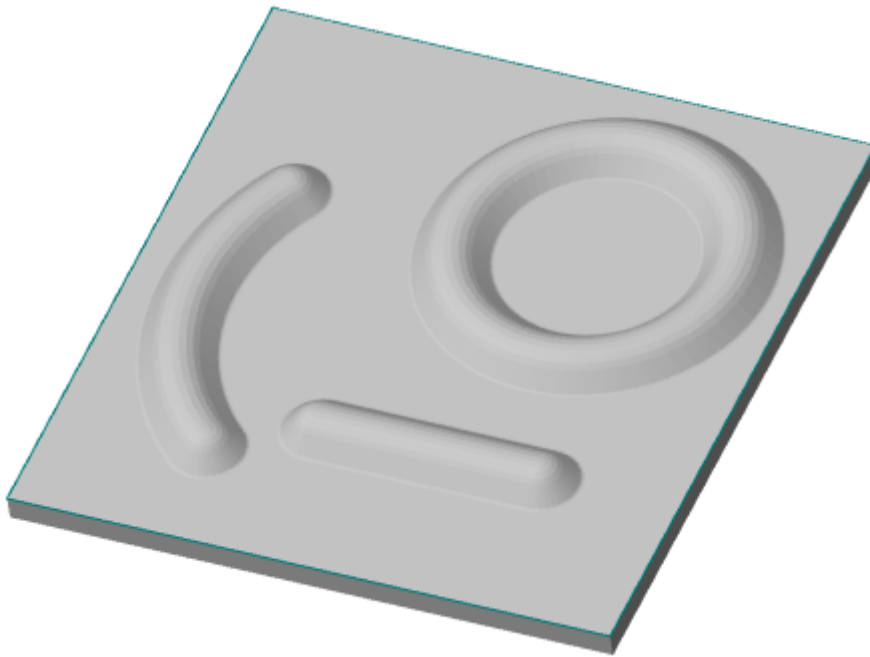

## Dialog

Sketch

Parameters

Height	<input type="text" value="5"/>
Base fillet radius	<input type="text" value="1"/>
Bottom fillet radius	<input type="text" value="1"/>
Angle	<input type="text" value="45"/>
Stamping direction	<input type="checkbox"/>
Type of bead	<input type="text" value="V-Type"/>
Type of ending	<input type="text" value="Closed"/>

Sketch is not selected

 ?

## 3D History





 "Bead". As part of the  body.

The following context menu commands are available:

- **Edit** - calls the object for editing. The edit symbol appears to the right of the icon .
- **Rename (F2)** - allows you to rename an object.
- **Delete (Del)** - removes an object from tree and model space.
- **Suppress** - removes an object from model space.
- **Unsuppress** - restores the object in model space.
- **ShowInDocument** - focuses and highlights the subject in the center of model space.
- **Rebuild** - rebuilds an object in model space.

## Rib

**Important!** This functionality requires a C3D 3D modeling engine.

-  Main menu: **3D - Sheet metal - Rib**.
-  Ribbon: **3D Tools - Sheet solids - Rib**.
-  Toolbar: **Sheet metal - Rib**.
-  Command line: **SMRIB**.

### Procedure

1. Call command **Rib**. The **Rib** dialog will open.

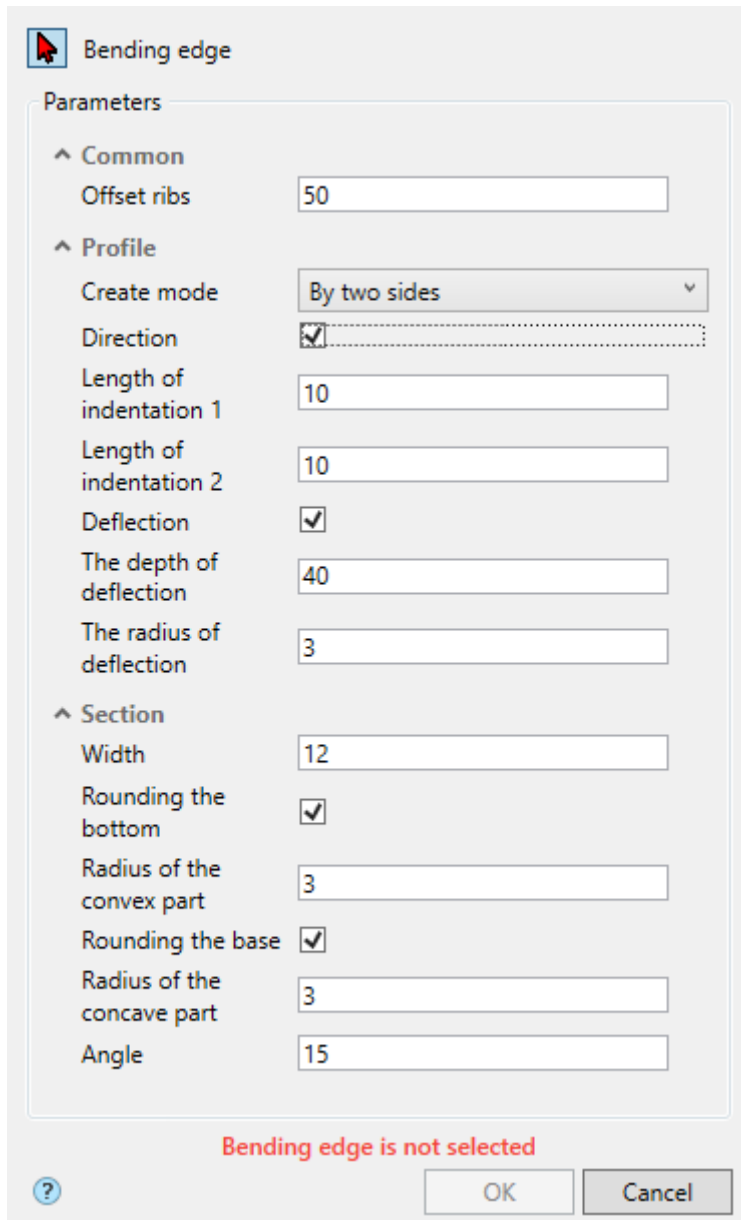

**Bending edge**

Parameters

- ^ Common
  - Offset ribs
- ^ Profile
  - Create mode
  - Direction
  - Length of indentation 1
  - Length of indentation 2
  - Deflection
  - The depth of deflection
  - The radius of deflection
- ^ Section
  - Width
  - Rounding the bottom
  - Radius of the convex part
  - Rounding the base
  - Radius of the concave part
  - Angle

Bending edge is not selected

2. Select an edge at the bend location. Red cursor  means selection mode is on. If the edge is not selected, the corresponding red text **"Bending edge is not selected"** is displayed.

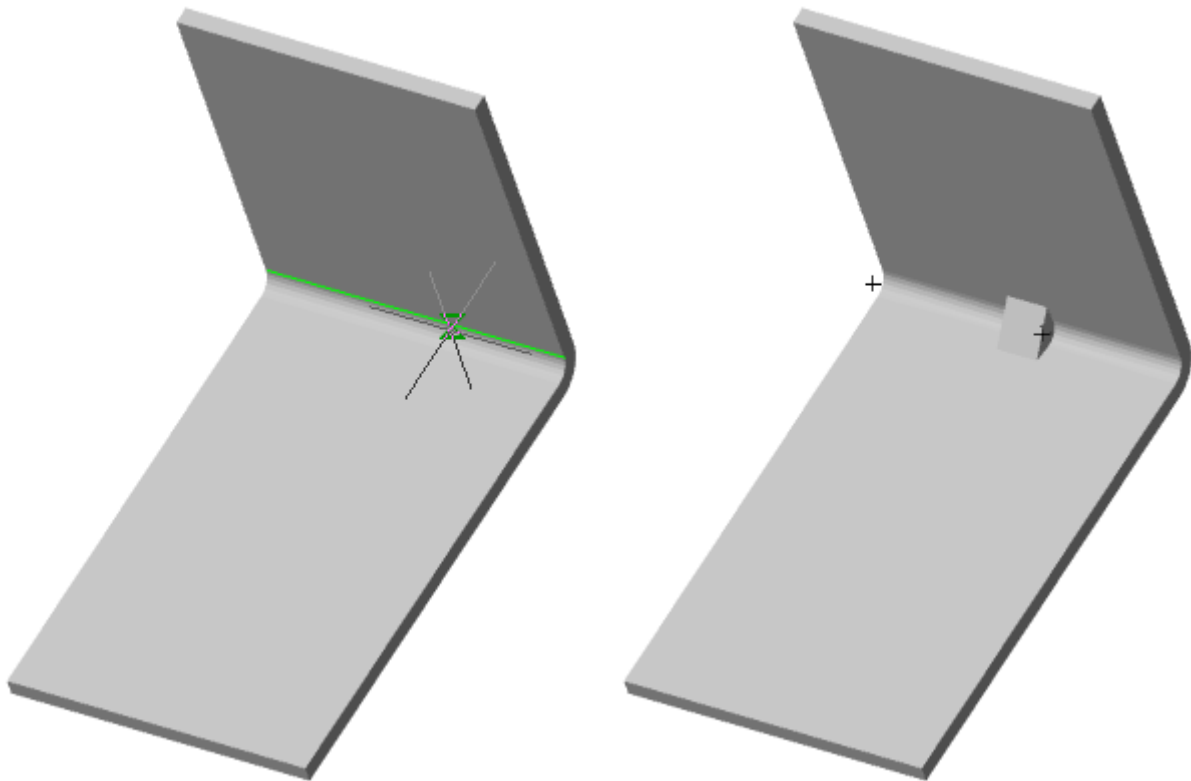

If you need to replace an edge (select another), enter the selection mode again by pressing the  **"Bending edge"** button.

3. Specify the required parameters.

4. Confirm the action with the **"OK"** button. The rib will be built. If the **"OK"** button is inactive, it means that the object was not selected or the parameters were set incorrectly. In the **"3d History"** object  **"Rib"** will be created, with a connection to an existing or new body.

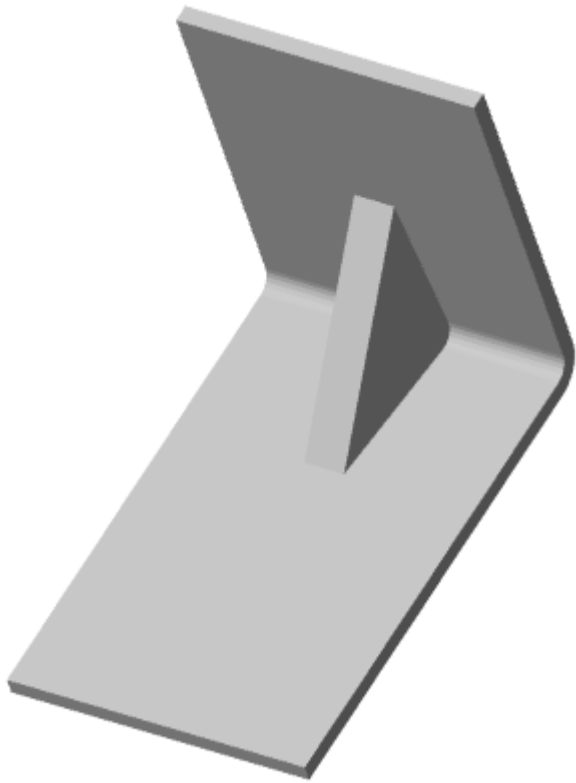

## Dialog

Bending edge

Parameters

^ Common

Offset ribs

^ Profile

Create mode

Direction  .....

Length of indentation 1

Length of indentation 2

Deflection

The depth of deflection

The radius of deflection

^ Section

Width

Rounding the bottom

Radius of the convex part

Rounding the base



Radius of the concave part

Angle

Bending edge is not selected

?
OK
Cancel

## 3D History

 "Rib". As part of the  body.

The following context menu commands are available:

- **Edit** - calls the object for editing. The edit symbol appears to the right of the icon .
- **Rename (F2)** - allows you to rename an object.
- **Delete (Del)** - removes an object from tree and model space.
- **Suppress** - removes an object from model space.
- **Unsuppress** - restores the object in model space.
- **ShowInDocument** - focuses and highlights the subject in the center of model space.
- **Rebuild** - rebuilds an object in model space.

## Flanging

**Important!** This functionality requires a C3D 3D modeling engine.



 Main menu: **3D - Sheet metal - Flanging**.

 Ribbon: **3D Tools - Sheet solids - Flanging**.

 Toolbar: **Sheet metal - Flanging**.

 Command line: **SMFLANGING**.

### Procedure

1. Call command  **"Flanging"**. The **"Flanging"** dialog will open.
2. Select the edges on the sheet body. The red cursor  means that the selection mode is enabled. If an edge is not selected, the corresponding red caption "Not selected: Edges" is displayed.



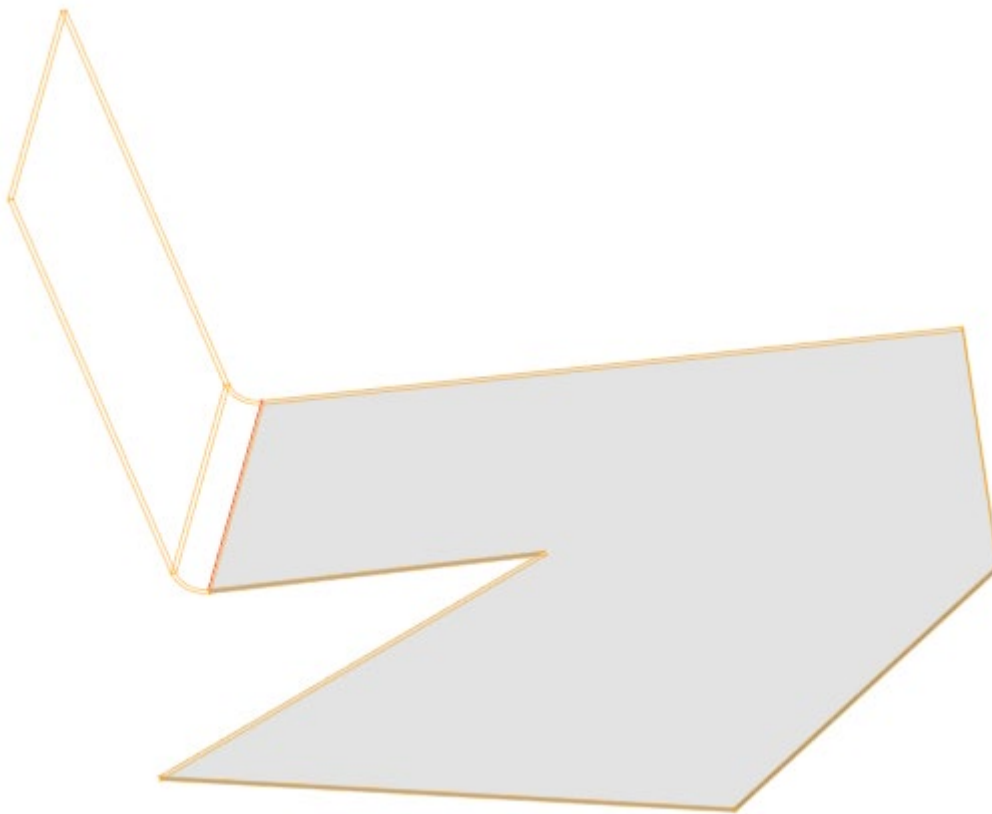
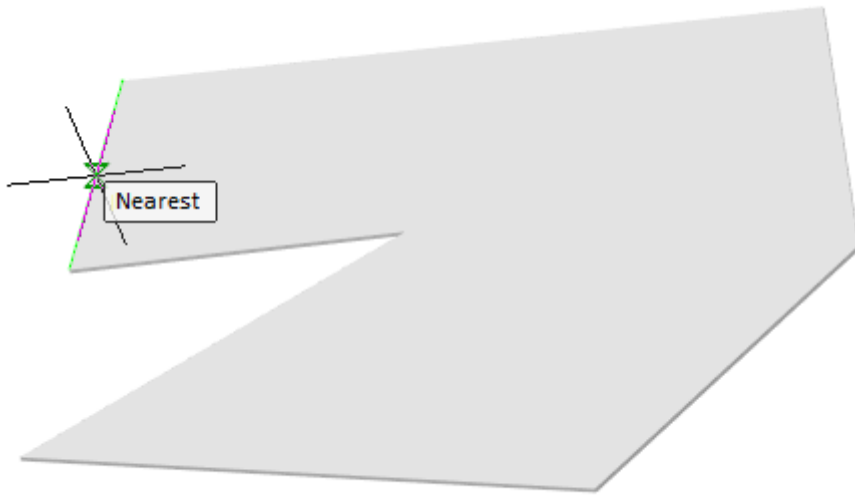

Select the required number of ribs. To cancel the selection, reselect the edge.

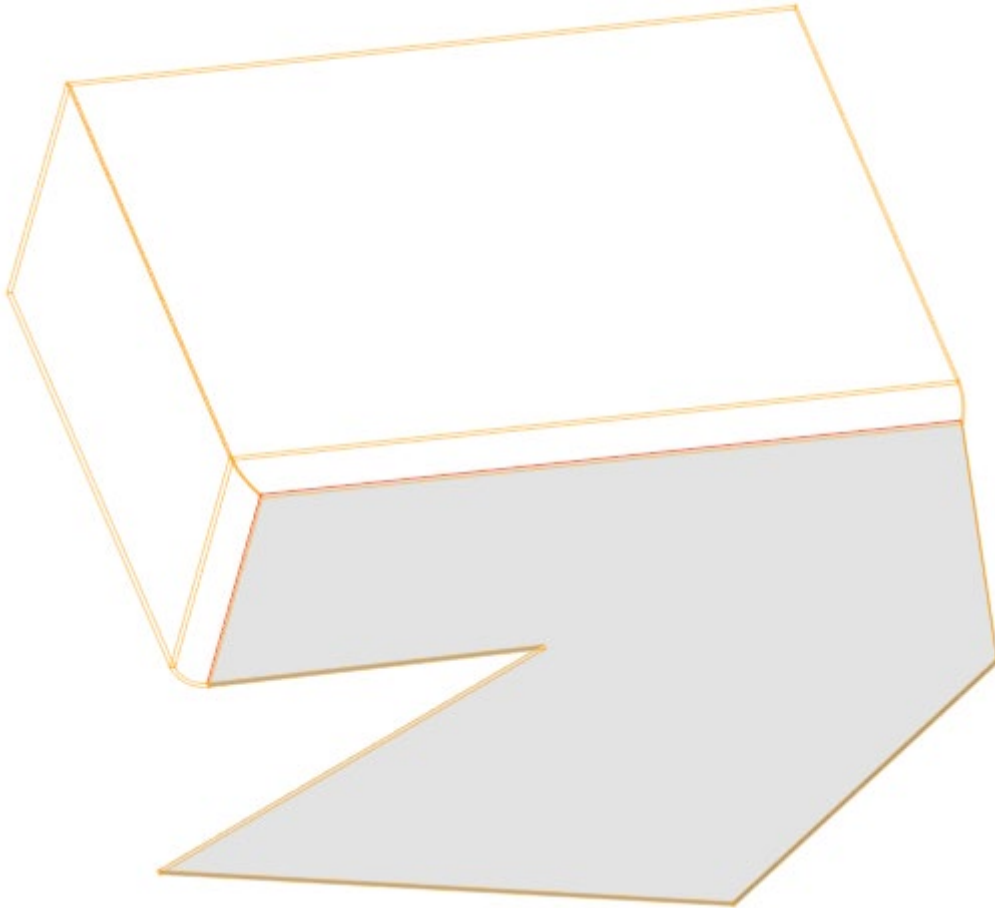

To complete the selection, select the **"Finish"** context menu command. If you need to replace the edge (select another one), enter the selection mode again by pressing the **"Ribs"** button.

3. Specify the required parameters on the form.

5. Confirm the action on the **"OK"** button. The flanging will be built. If the **"OK"** button is inactive, it means that the object was not selected or the parameters were set incorrectly. In the **"3D History"** the **"Flanging"** object will be created, with reference to an existing or new part.

## Dialog

### 3D History

**"Flanging"**. As part of the  body.

The following context menu commands are available:

- **Edit** - calls the object for editing. The edit symbol appears to the right of the icon .
- **Rename (F2)** - allows you to rename an object.
- **Delete (Del)** - removes an object from tree and model space.
- **Suppress** - removes an object from model space.
- **Unsuppress** - restores the object in model space.
- **ShowInDocument** - focuses and highlights the subject in the center of model space.
- **Rebuild** - rebuilds an object in model space.

## Editing

### 3D Align

 Main menu: **3D -3D Features - 3D Align.**

 Ribbon: **3D Tools - Solid Editing - 3D Align.**

 Toolbar: **3D - 3D Align.**

 Command line: **3DALIGN.**

A tool for pairing surfaces, curves, or points in model space.

**Note:** Information about the alignment does not fall into the **"3DHistory"**.

### Procedure

1. Call command  **"3D Align"**.
2. Specify the objects that you want to align. To complete the selection, press the **"Enter"** key. The dialog **"3D Align"** will open.

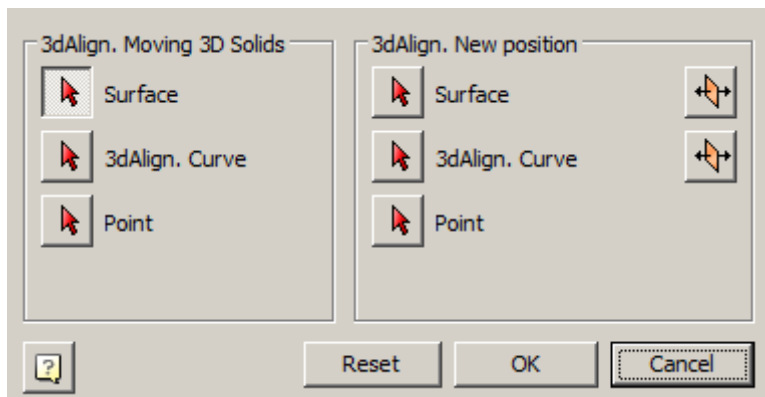

3. Use the "3D Align" dialog to select the locations in one of three ways:
  - **Surface to Surface.** The surface can be a face of a part or a plane. In this method, the surface is adjacent to the surface. When using the button  **"Change Direction"** the direction of aligned objects is changing.

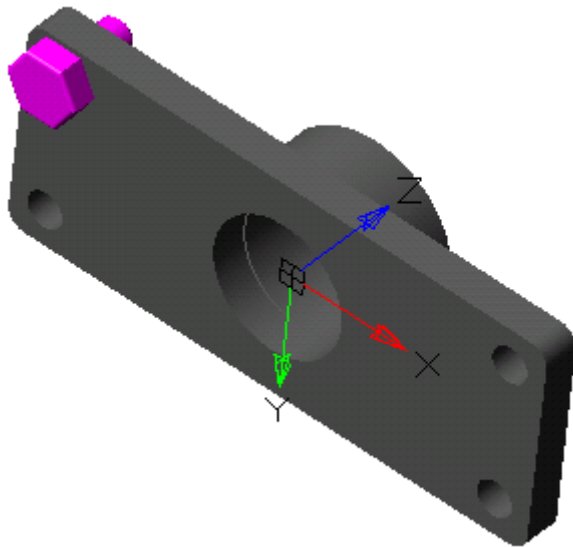
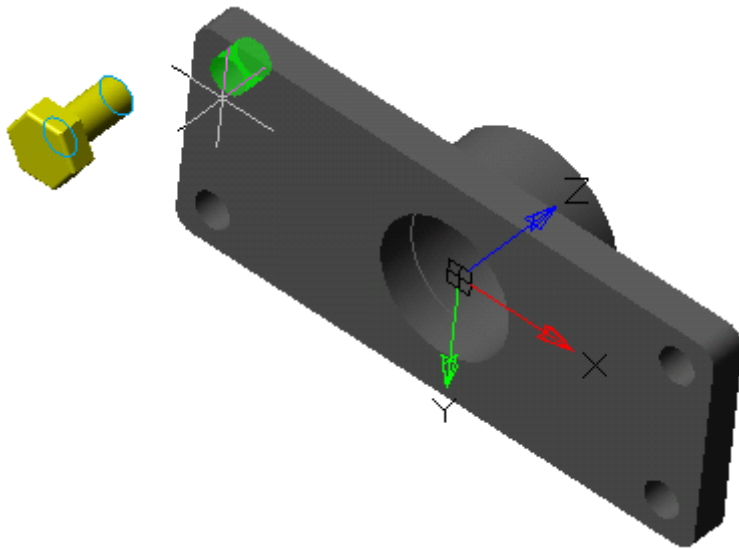

- **Curve to Curve.** The axis can be an edge of the part or an axis. In this method, the selected axes are combined. When using the button  "**Change Direction**" the direction of aligned objects is changing.

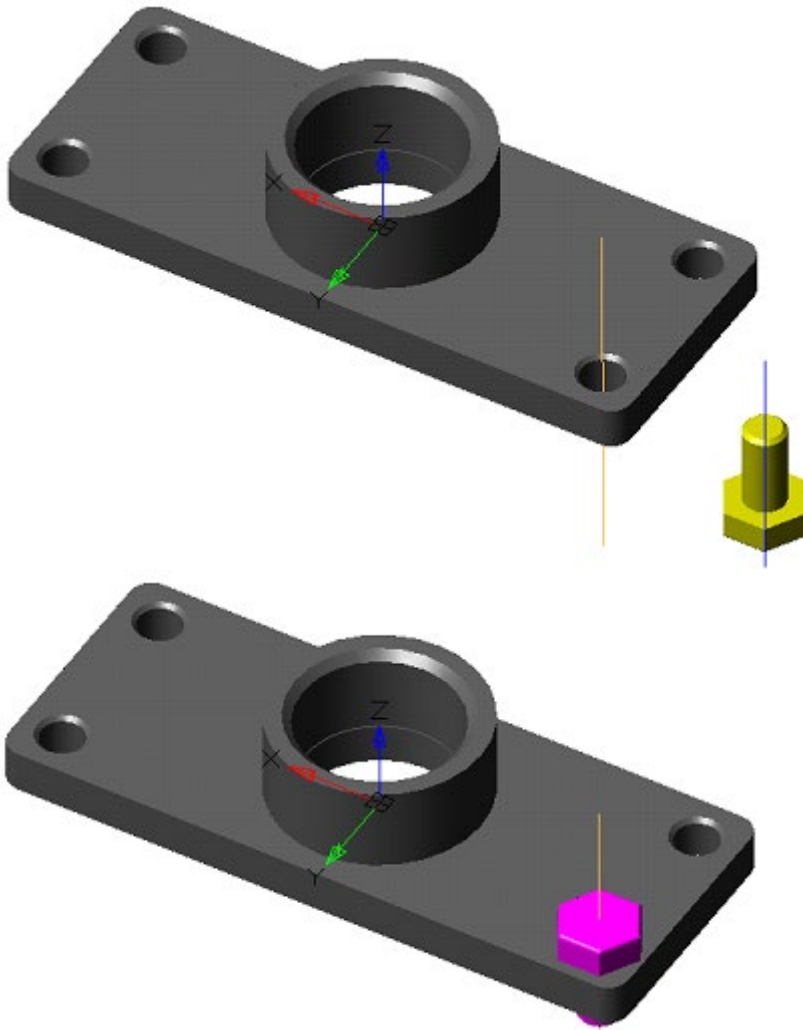

- **Point to point.** In this method, points are combined.

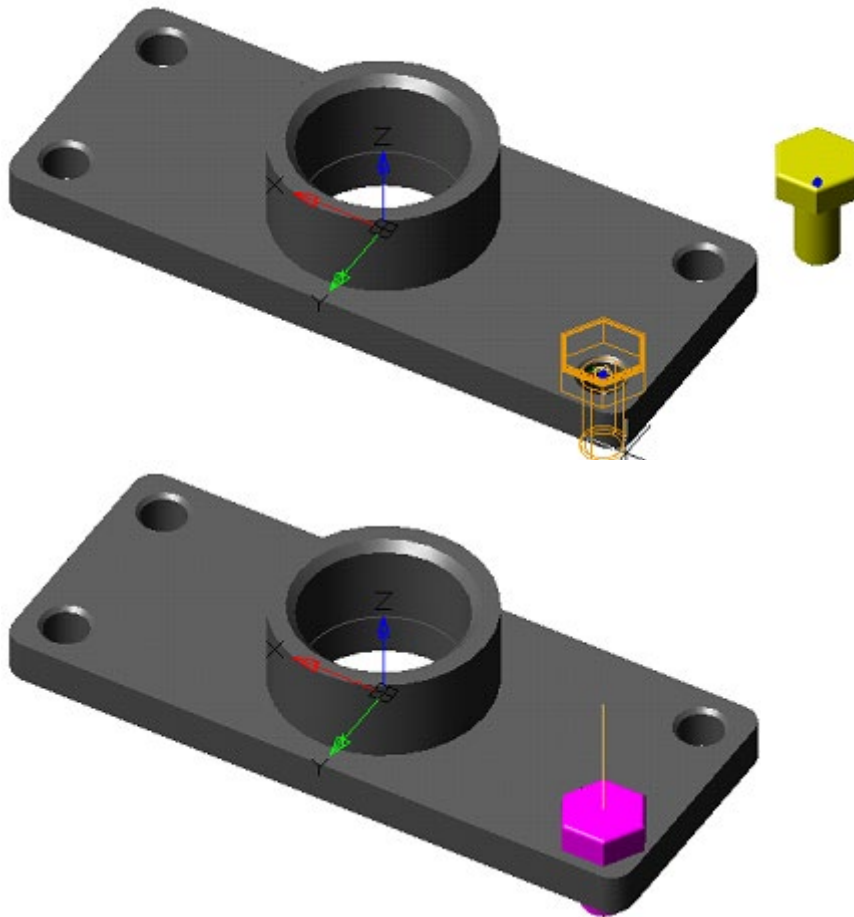

4. When all the locations have been selected, click **"OK"**. Alignment will be performed.

## ***Manipulators***

Manipulators allow you to manipulate the 3D model: move, rotate or change the scale.

There are two ways to use manipulators:

1. Force a call using the appropriate commands: [3D Move](#), [3D Rotate](#), [3D Scale](#).
2. Automatic call of the configured manipulator when selecting a 3D model (the call does not work in 2D Wireframe mode).

### ***Setting up automatic call***

The DEFAULTMANIPULATOR system variable (default keyer) is responsible for configuring the automatic call of the manipulator.

Manipulators and how to install them:

1. Move Manipulator



Main menu: **3D - 3D Features -  Move Manipulator.**



Ribbon: **3D Tools - Manipulators -  3D Move Manipulator.**



Toolbar: **3D Transformations -  Move Manipulator.**

 Command line: **DEFAULTMANUPULATOR1.**

 Command line: **DEFAULTMANUPULATOR** - set to 1 or select "**Move manipulator**".

## 2. Rotate Manipulator

 Main menu: **3D -3D Features** -  **Rotate Manipulator.**

 Ribbon: **3D Tools - Manipulators** -  **3D Rotate Manipulator.**

 Toolbar: **3D Transformations** -  **Rotate Manipulator.**

 Command line: **DEFAULTMANUPULATOR2.**

 Command line: **DEFAULTMANUPULATOR** - set to 2 or select "**Rotate manipulator**".

## 3. Scale Manipulator

 Main menu: **3D -3D Features** -  **Scale Manipulator.**

 Ribbon: **3D Tools - Manipulators** -  **3D Scale Manipulator.**

 Toolbar: **3D Transformations** -  **Scale Manipulator.**

 Command line: **DEFAULTMANUPULATOR3.**

 Command line: **DEFAULTMANUPULATOR** - set to 3 or select "**Scale manipulator**".

## 4. No Manipulator

 Main menu: **3D - 3D Features** -  **No Manipulator.**

 Ribbon: **3D Tools - Manipulators** -  **Without Manipulator.**

 Toolbar: **3D Transformations** -  **No Manipulator.**

 Command line: **DEFAULTMANUPULATOR4.**

 Command line: **DEFAULTMANUPULATOR** - set to 4 or select "**No manipulator**".

## **3D Move**

 Main menu: **3D - 3D Features** -  **3D Move.**

 Ribbon: **3D Tools - Solid Editing** -  **3D Move.**

 Toolbar: **3D** -  **3D Move.**

 Toolbar: **3D Transform** -  **3D Move**.

 Command line: **3DMOVE**.

Tool for moving part in model space.

### **Important!**

Without the 3D module for "Nonparametric solid" objects, the manipulator works in demo mode, i.e. there will be no actual movement.

### *Procedure*

1. Call command  "**3D Move**".
2. Select part in model space or in "**3D History**". The sketch part should not be tied to one of the main planes of the model. The selected parts are highlighted in green, and the selected ones in yellow. You can select multiple parts in one operation. After completing the selection, press the "**Enter**" key or the "**Enter**" command from the context menu.

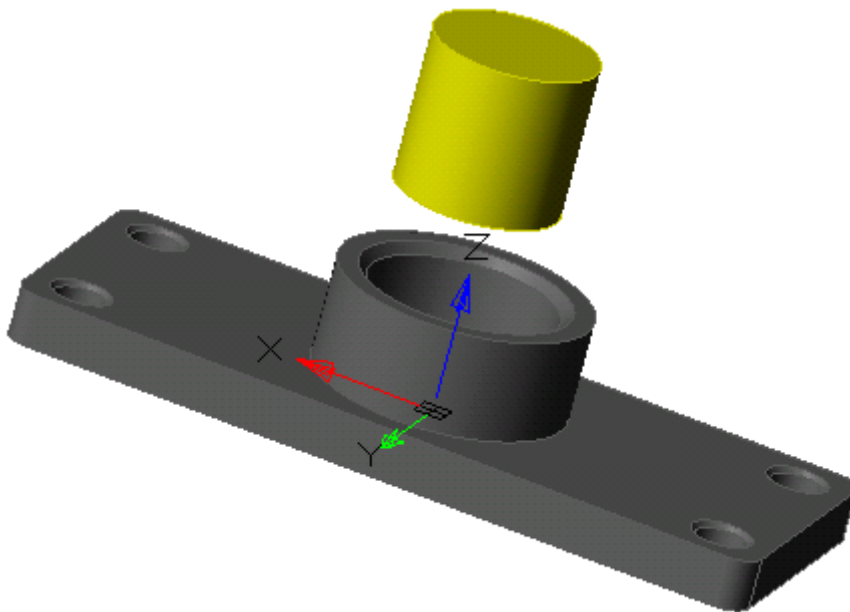

3. Select the axis or plane along which the movement will occur.



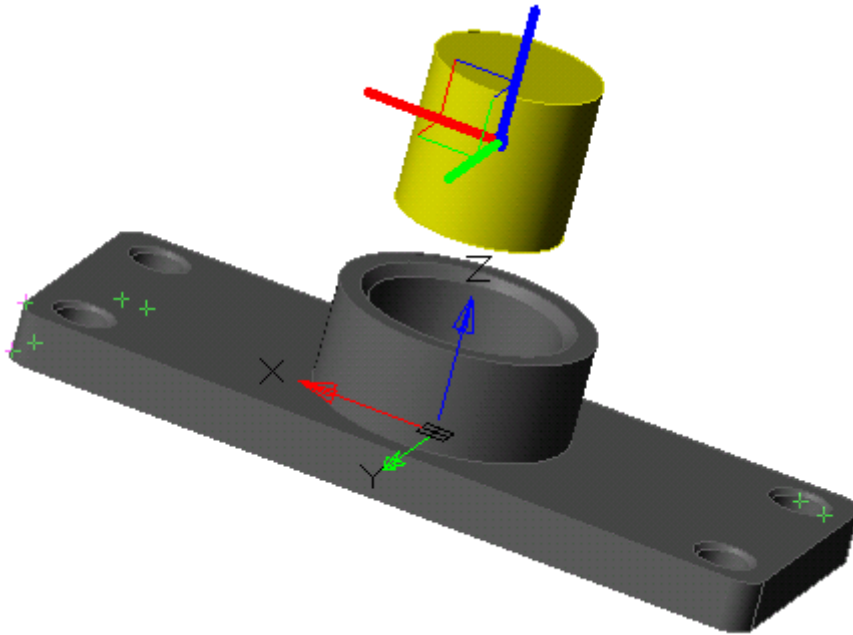

4. Forward movements of the mouse move part along the selected axis (plane). You can also enter the value of the navigation from the keyboard.

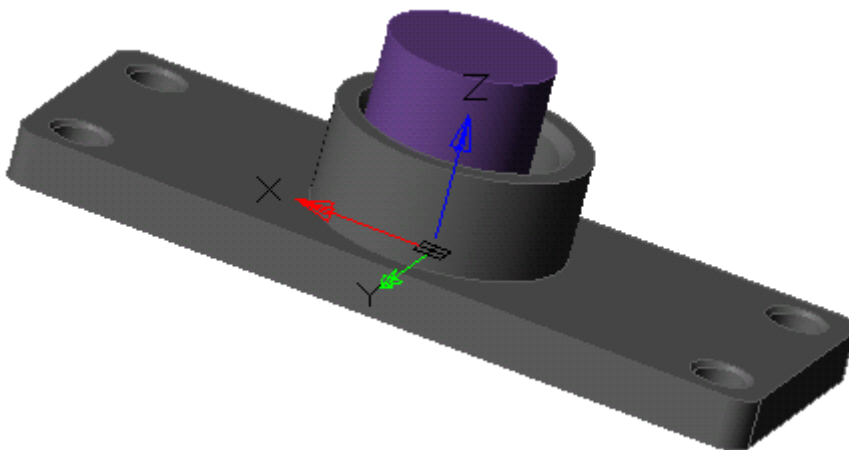

5. Repeat the movement as many times as necessary (p.3-p.4). When the transfer is complete, press the **"Enter"** key or the **"Enter"** command from the context menu.

## 3D Rotate



Main menu: **3D - 3D Features - 3D Rotate.**



Ribbon: **3D Tools - Solid Editing - 3D Rotate.**



Toolbar: **3D - 3D Rotate.**



Toolbar: **3D Transform - 3D Rotate.**



Command line: **3DROTATE.**

Tool for rotating part in model space.

**Important!**

Without the 3D module for "Nonparametric solid" objects, the manipulator works in demo mode, i.e. there will be no actual movement.

**Procedure**

1. Call command  **"3D Rotate"**.
2. Select the rotating part in the model space or in the **"3D History"**. The sketch part should not be tied to one of the main planes of the model. The selected parts are highlighted in green, and the selected ones in yellow. You can select multiple parts in one operation. When the selection is complete, press the **"Enter"** key or the **"Enter"** command from the context menu.

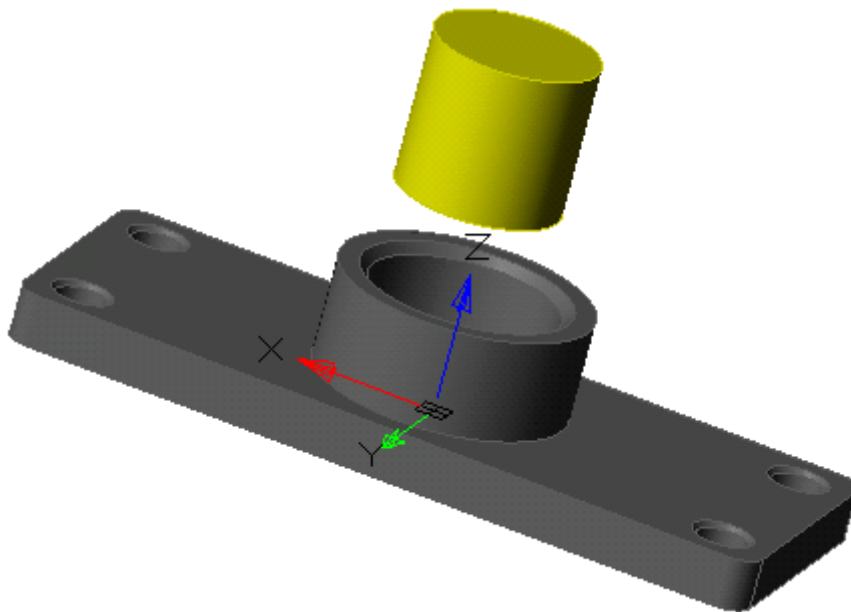

3. Select the base point on the rotated part. This point will be the center of rotation around the selected axis.

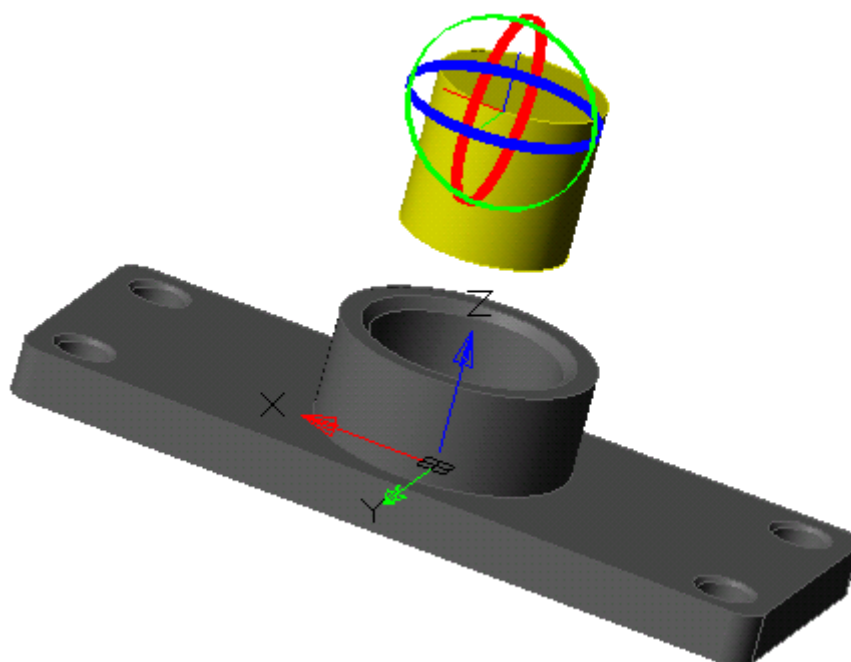

4. Select the axis along which the rotation will occur.

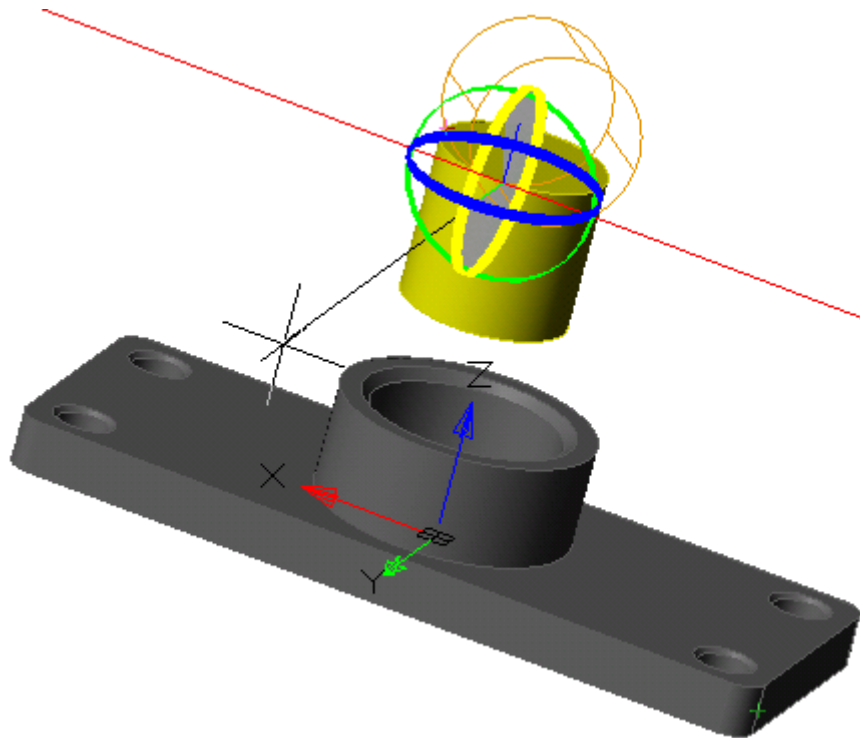

5. In the forward movements of the mouse, rotate the part along the selected axis. You can also enter the value of the rotation angle from the keyboard.

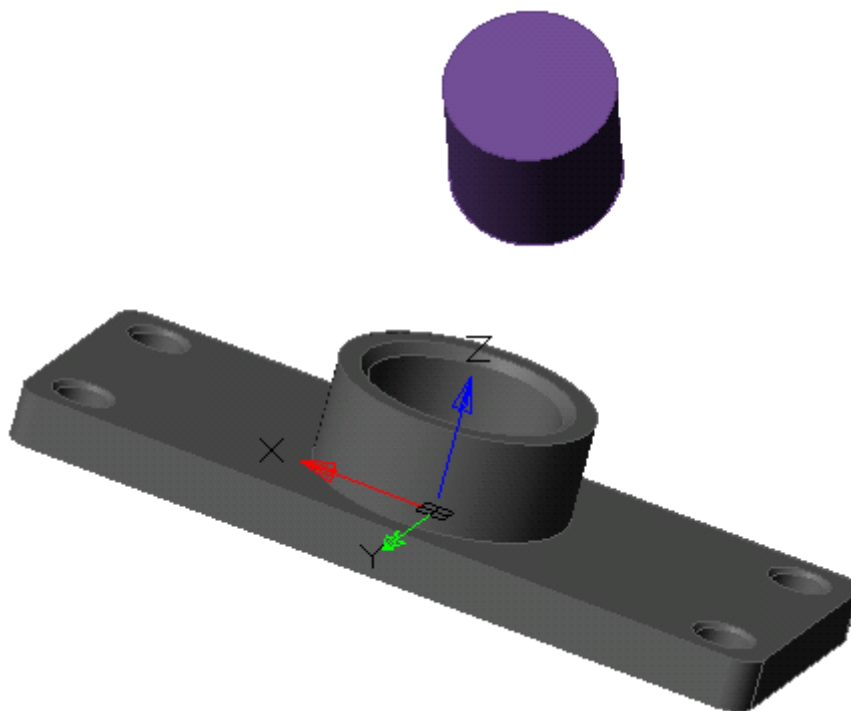

6. Repeat the rotation as many times as necessary (p.3-p.5). When the transfer is complete, press the **"Enter"** key or the **"Enter"** command from the context menu.

### 3D Scale



Main menu: **3D - 3D Features - 3D Scale.**

 Ribbon: **3D Tools - Solid Editing - 3D Scale**.

 Toolbar: **3D - 3D Scale**.

 Toolbar: **3D Transform - 3D Scale**.

 Command line: **3DSCALE**.

3D scaling allows you to resize selected objects and subobjects along an axis or a plane or to scale objects uniformly.

**Important!** The command applies only to objects **"3D Solid"** and **"Polyface Mesh"**

**Important!** Without the 3D module for "Nonparametric solid" objects, the manipulator works in demo mode, i.e. there will be no actual movement.

### *Procedure*

1. Call command  **"3D Scale"**;
2. Select objects that require scaling;

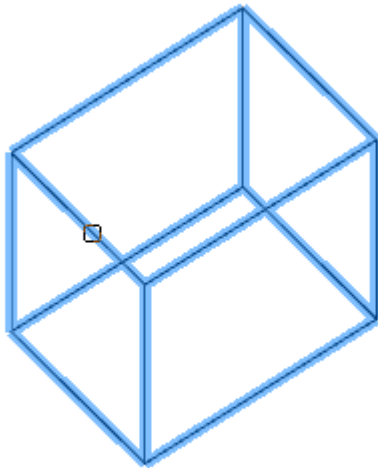

3. Press the key **"Enter (Space)"**;
4. Specify the base point of scaling;

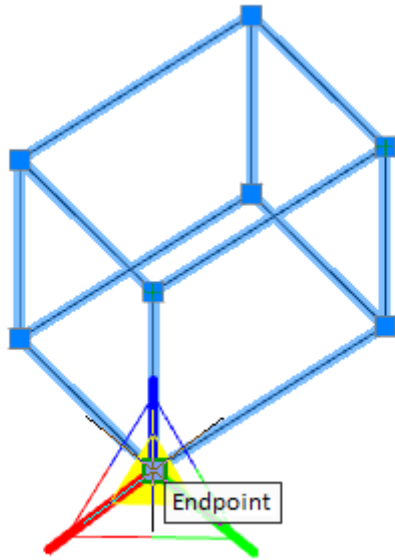

5. Specify a scale axis or a scale plane;

- **Same scale.** Click the area near the top of the 3D Scaling. The internal part of all axes stands out. Scaling will be performed evenly across all three axes.

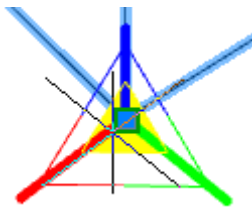

- **Limitation of scaling by the position of the plane.** Click between the parallel lines located between the axes defining the plane. Scaling will be done in two axes. This operation is only for Mesh, it is not applicable to 3D Solid and surfaces.

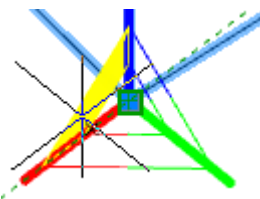

- **Scale limiting by axis position.** Click the Axis. Scaling will be done on one axis. This operation is only for Mesh, it is not applicable to 3D Solid and surfaces

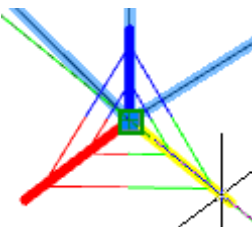

6. Set the scale (on the drawing or on the command line), objects will be scaled;

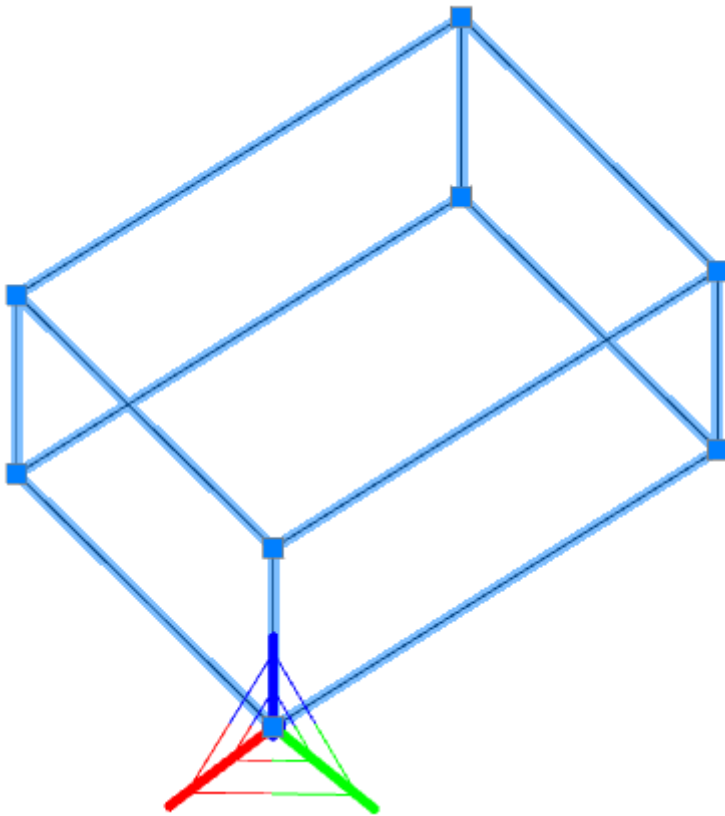

7. Repeat steps 4-6 as many times as necessary. To end the command, press **"Esc (Space)"**.

### ***3D Rectangular Array***



Main menu: **3D - 3D Features -  3D Rectangular Pattern.**



Ribbon: **3D Tools - Solid Editing -  3D Rectangular Array.**



Toolbar: **3D -  3D Rectangular Pattern.**



Command line: **3DRECTPAT.**

Tool for creating an array in one or two directions.

### ***Procedure***

1. Call command  **"3D Rectangular Pattern"**. Open dialog **"3D Rectangular Pattern"**.

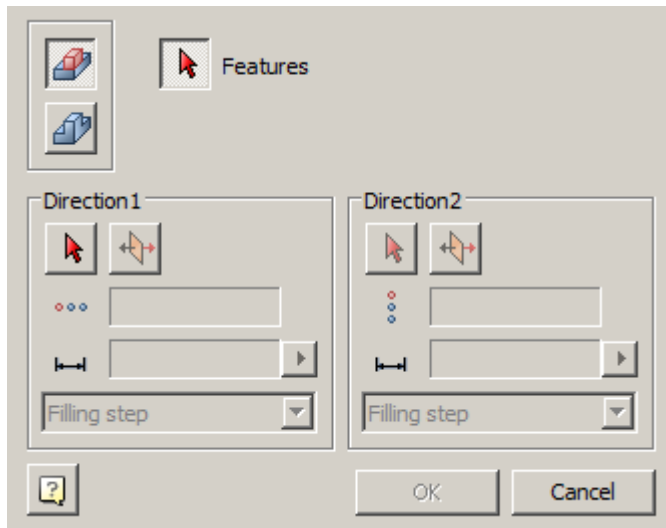

2. Select the type of objects involved in the creation of the array:

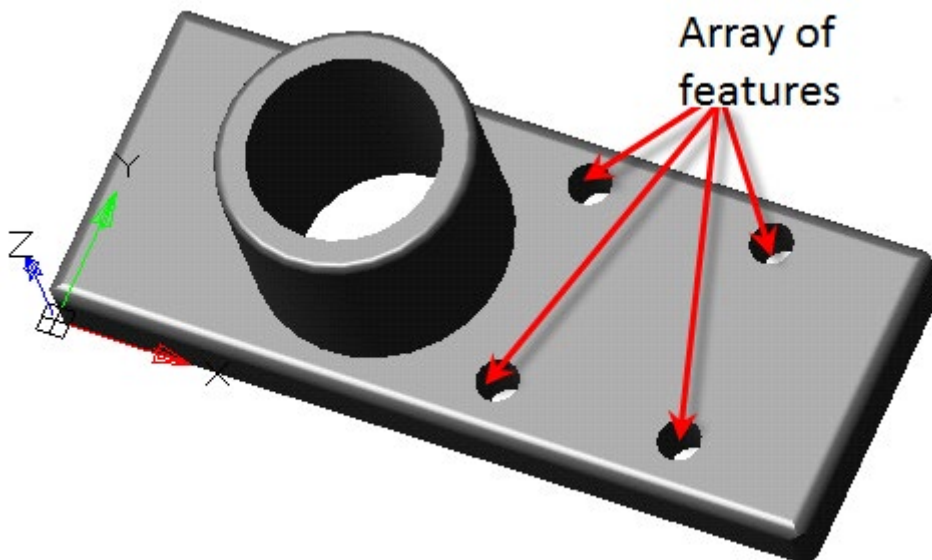

-  Array of features. An array of elements will refer to the original body.



**Note:**

Chamfers and fillets can not be received by the array as separate elements; You can not make an array of chamfers or fillets!

Chamfers and fillets can be used only as a part of bodies.

-  Array of bodies. The whole body goes to the array, a new body with an element will be created  "**McRectangularPatternFeature**".

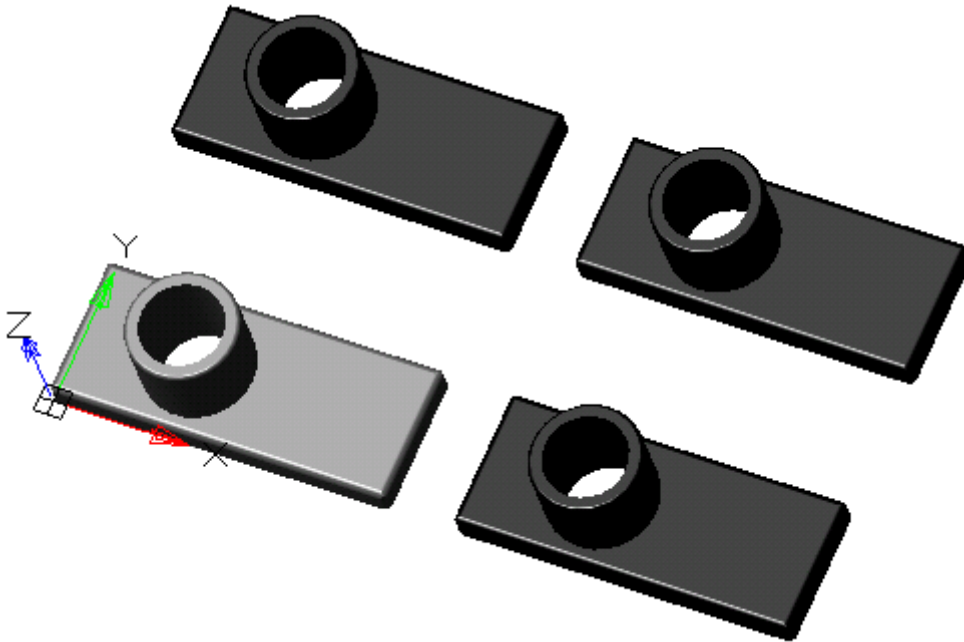





3. Select elements to create an array.
4. Adjust the array parameters, or take them from the sample array.

#### Parameters from sample array:



- Press button  **"Get parameters from sample array"**.
- Specify sample array.
- The created array will be passed: direction, quantity, distance and type of distance.





#### Specifying parameters yourself:

- Select the first direction of the array. The axis of the GCS, the working axis or the edge of any body can be used as a direction. The phantom of the created array is highlighted in orange.
- Invert if necessary the direction of the layout of elements with the button  **"Flip direction"**.
- Specify the number of copies in the input field  **"Count elements"**.
- Enter the distance in the input field  **"Distance"**. To the right of the input field is a button  **"Measure distance"**, allowing you to take a value from the drawing.
- Select distance type:
  - **Filling step** - sets the distance between each element in the array.
  - **Filling range** - sets the distance between the extreme elements in the array.
- Repeat steps for the second direction, if the array is built in two directions.

5. Press button **"OK"**. An array will be created based on the selected items. In the **"3D History"** an object appears  **"McRectangularPatternFeature"**.

### 3D History

 **"McRectangularPatternFeature"**. It is part of the body. When creating an array from the elements of the source body, the object  **"McRectangularPatternFeature"** falls into the composition of the original body. When creating an array from the source body, a new body is created, object  **"McRectangularPatternFeature"** falls into the new body.

The object  **"McRectangularPatternFeature"** includes: folder  **"Elements"** with a list of source elements or folder  **"Solids"** with a list of source bodies, and links  **"Occurrence"**, showing the elements of the array in model space.



The following commands of the object's context menu are available

 **"McRectangularPatternFeature":**

- **Edit** - opens the editing dialog **"3D Rectangular Pattern"**.
- **Rename (F2)** - allows you to rename a pattern.
- **Delete (Del)** - removes a pattern from the tree and model space.
- **Suppress** - removes a pattern from model space.
- **Unsuppress** - restores a pattern in model space.
- **ShowInDocument** - focuses and highlights a pattern in the center of model space.
- **Rebuild** - rebuilds an object in model space.

## 3D Polar Array



Main menu: **3D - 3D Features -  3D Circular Pattern.**



Ribbon: **3D Tools - Solid Editing -  3D Polar Array.**



Toolbar: **3D -  3D Circular Pattern.**



Command line: **3DCIRCPAT.**

Tool for creating an array of elements or bodies around a certain axis.

### Procedure

1. Call command  **"3D Circular Pattern"**. Open dialog **"3D Circular Pattern"**.

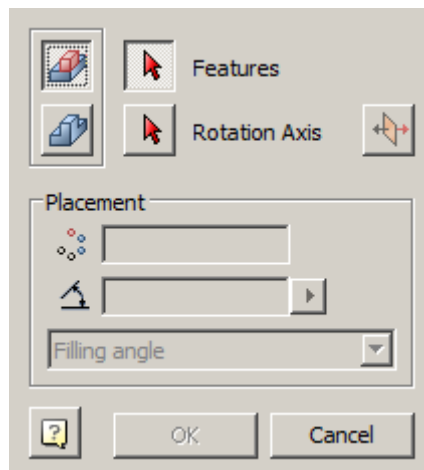

2. Select the type of objects involved in the creation of the array:

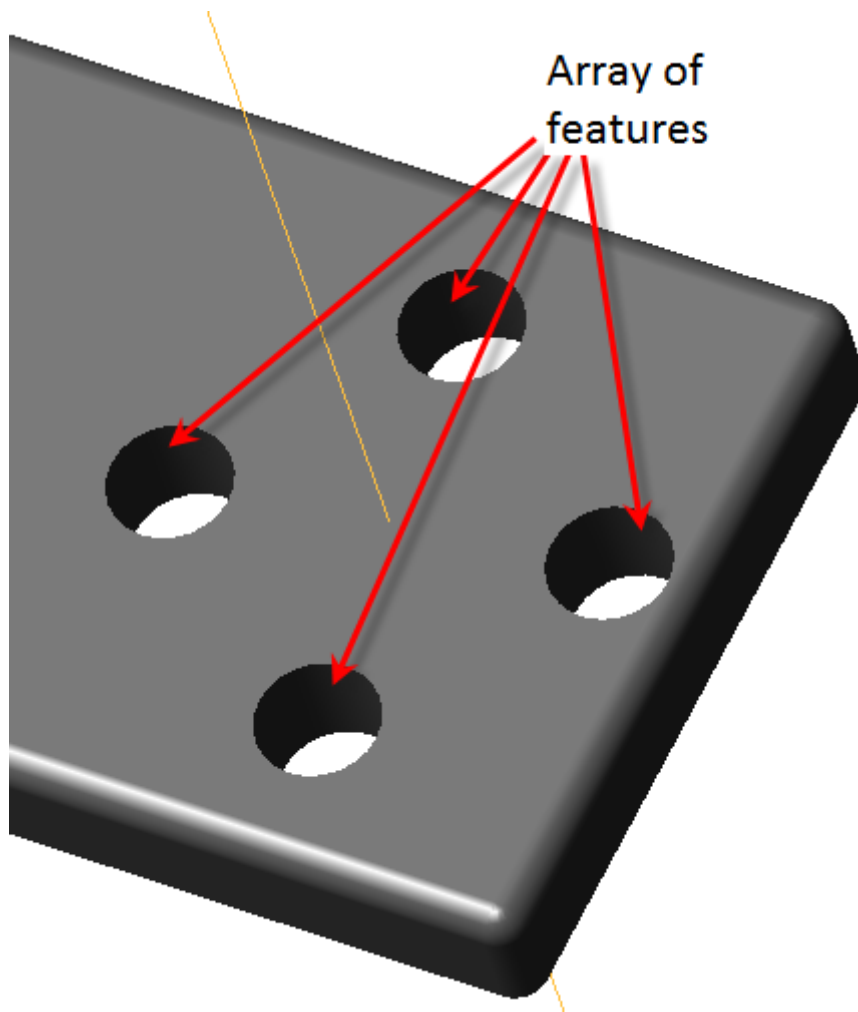

-  Array of features. An array of elements will refer to the original part.



**Note:**

Chamfers and fillets can not be received by the array as separate elements; You can not make an array of chamfers or fillets!

Chamfers and fillets can be used only as a part of bodies.

-  Array of bodies. The whole body goes to the array, a new body with an element will be created  **"McCircularPatternFeature"**.

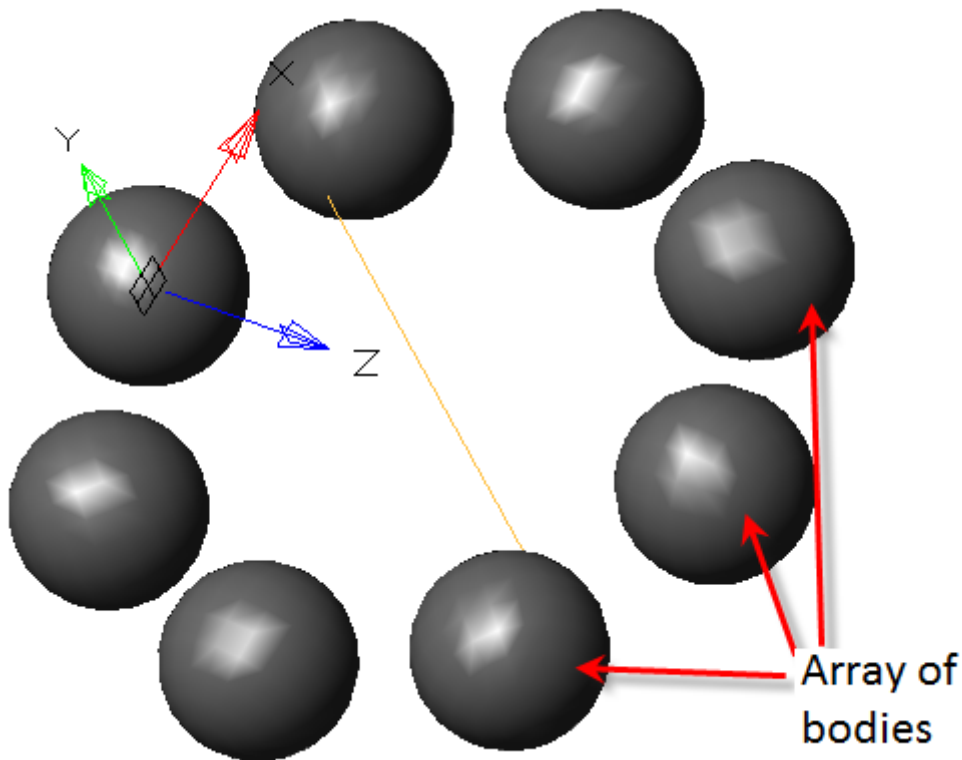

3. Select elements to create an array.
4. Adjust the array parameters, or take them from the sample array.

#### Parameters from sample array:

- Press button  **"Get parameters from sample array"**.
- Specify sample array.
- The following will be passed to the created array: axis of rotation, direction, amount, angle and type of filling.





#### Specifying parameters yourself:

- Select the axis. As an axis, the GCS axis, the working axis or the edge of any body can be used. Orange color is highlighted by a phantom of the created array.

#### Important!

The edges of the bodies involved in the creation of the array cannot be used as an axis. It turns out that one edge participates in several closed shells, and the parts to be combined can never exactly touch each other. Existing 3D kernels process this data incorrectly, so such an array is likely to be built erroneously.



In order to correct, you can use the auxiliary axis, slightly shifted in parallel from the desired one, for example, by 1  $\mu\text{m}$ .





- Invert if necessary the direction of the layout of elements with the button  **"Flip direction"**. By default, the layout is clockwise.
- Enter the number of copies in the input field  **"Count of items"**.
- Specify the angle in the input field  **"Angle for items"**. To the right of the input field is the button  **"Measure angle"**, allowing you to take a value from the drawing.
- Specify the type of filling:
  - **Filling angle** - sets the value of the fill angle between the extreme elements in the array.

- **Spacing angle** - sets the value of the step between each element in the array.

5. Press button **"OK"**. An array will be created based on the selected elements. In the **"3D History"** object appears  **"McCircularPatternFeature"**.

### 3D History

 **"McCircularPatternFeature"**. It is part of the part. When creating an array from the elements of the source body, the object  **"McCircularPatternFeature"** falls into the composition of the original body. When creating an array from the source body, a new body, object  **"McCircularPatternFeature"** falls into the new body.

The object  **"McCircularPatternFeature"** includes: folder  **"Elements"** with a list of source elements or folder  **"Solids"** with a list of source bodies, and links  **"Occurrence"**, showing array elements in the model space.

The following commands of the object's context menu are available

 **"McCircularPatternFeature"**:

- **Edit** - opens the editing dialog **"3D Circular Pattern"**.
- **Rename (F2)** - allows you to rename an array.
- **Delete (Del)** - removes an array from the tree and model space.
- **Suppress** - removes an array from model space.
- **unsuppress** - restores an array in model space.
- **ShowInDocument** - focuses and highlights the array in the center of the model space.
- **Rebuild** - rebuilds the object in model space.

### 3D Fillet



Main menu: **3D - 3D Features -  3D Fillet.**



Ribbon: **3D Tools - Solid Editing -  Fillet Edge.**



Toolbar: **3D -  3D Fillet.**



Command line: **3DFILLET.**

Tool for creating different kinds of fillets.

### Procedure

1. Call command  **"3D Fillet"**. The **"3D Fillet"** dialog will be opened.

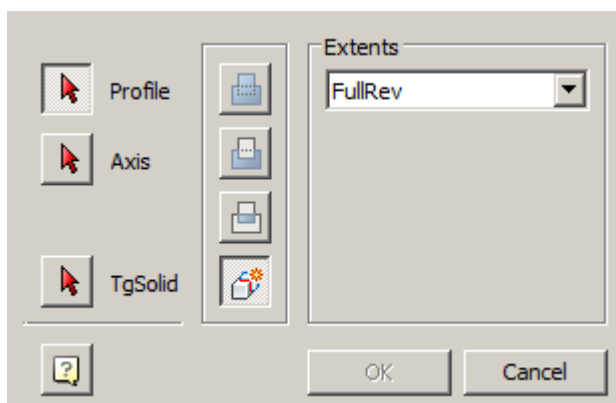

2. Define the rib selection method using the **"Edge chain"**.

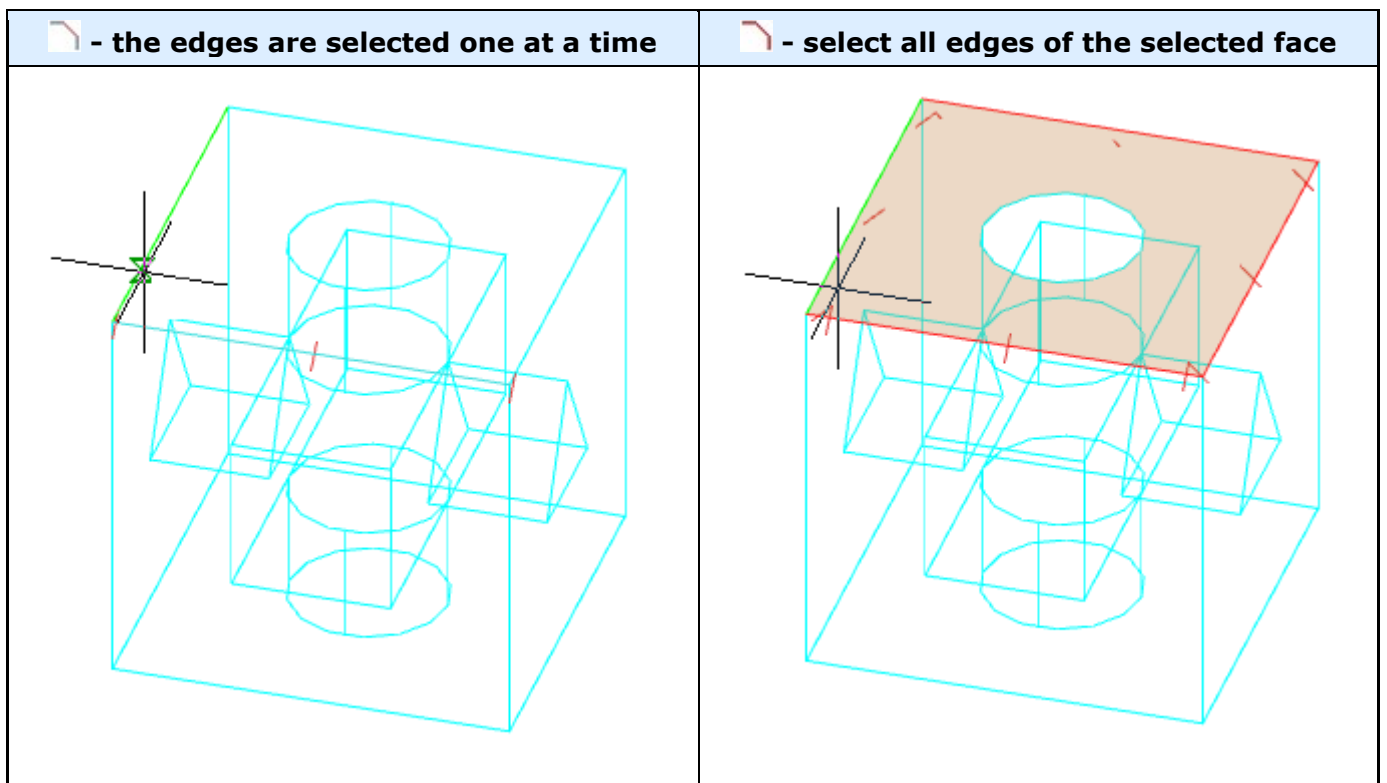

3. Select the edges. During the selection process, the rounding phantoms will be visible in the modeling environment.

4. Specify the radius. To the right of the radius input field is the button  **"Measure radius"**, allowing to take the value from the drawing.

5. Press the **"OK"** key. Fillets will be built. In the **"3D History"** in the part will be an object  **"McFilletFeature"**.

### 3D History

 **"McFilletFeature"**. It is found in the part.

The following shortcut menu commands are available:

- **Edit** - opens the editing dialog **"3D Fillet"**.
- **Rename (F2)** - allows you to rename a fillet.
- **Delete (Del)** - removes fillet from tree and model space.
- **Suppress** - removes fillet from model space.
- **Unsuppress** - restores the fillet in the model space.
- **ShowInDocument** - focuses and highlights the fillet at the center of the model space.
- **Rebuild** - rebuilds an object in model space.

### 3D Chamfer

 Main menu: **3D - 3D Features -  3D Chamfer.**

 Ribbon: **3D Tools - Solid Editing -  Chamfer Edge.**

 Toolbar: **3D -  3D Chamfer.**

 Command line: **3DCHAMFER**.

Tool for creating all kinds of chamfers.

### Procedure

1. Call command  "**3D Chamfer**". Open dialog "**3D Chamfer**".

#### Note:

Simultaneously, on two or more bodies the facet can not be built. You need to call the  "**3D Chamfer**" command for each body separately.

2. In the "**3D Chamfer**" dialog, select the method for creating the chamfer and specify the required parameters, depending on the method:

-  **Equal distances from both faces** - it makes it possible to build a chamfer in one dimension - length. The angle is automatically equal to 45°.

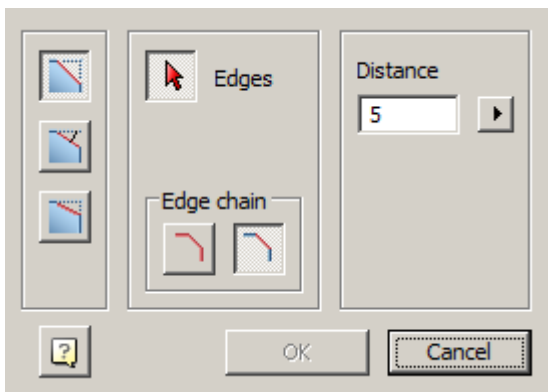

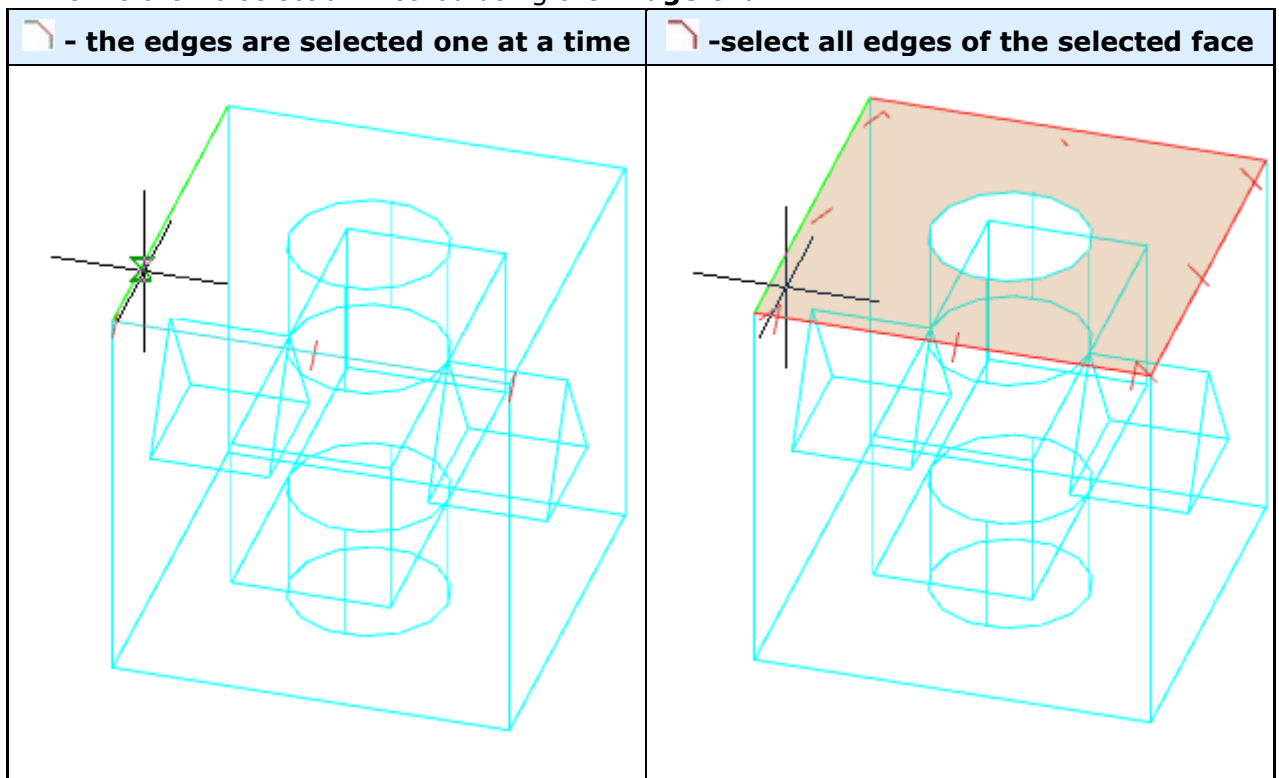

- Define the rib selection method using the "**Edge chain**".



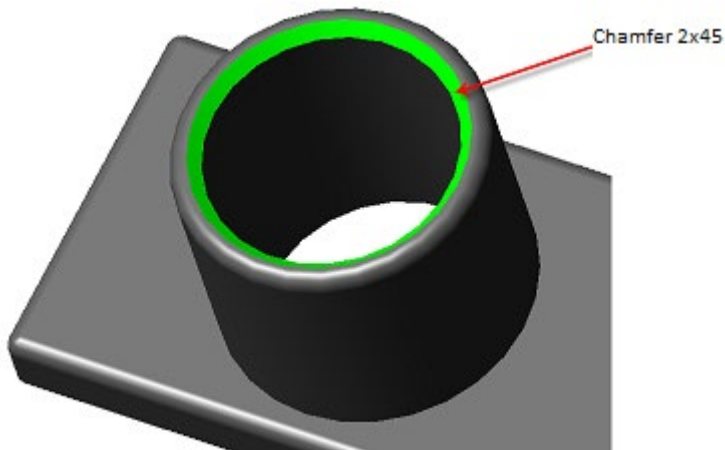

- Select the edges. During the selection process, the chamfering phantoms will be visible in the simulation environment.

- Enter the distance. To the right of the distance input field is the button  "**Measure distance**", allowing to take the value from the drawing.

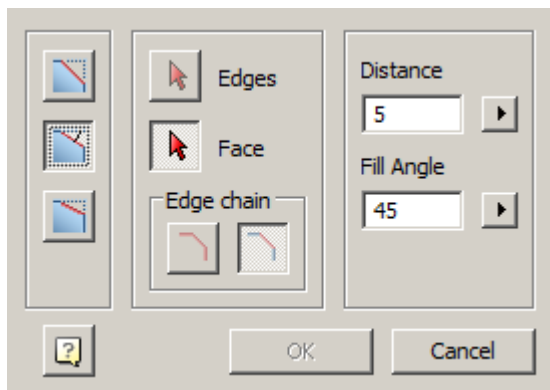

-  **Distance and angle from specify face** - it is possible to construct a facet by the angle and length of the selected face.



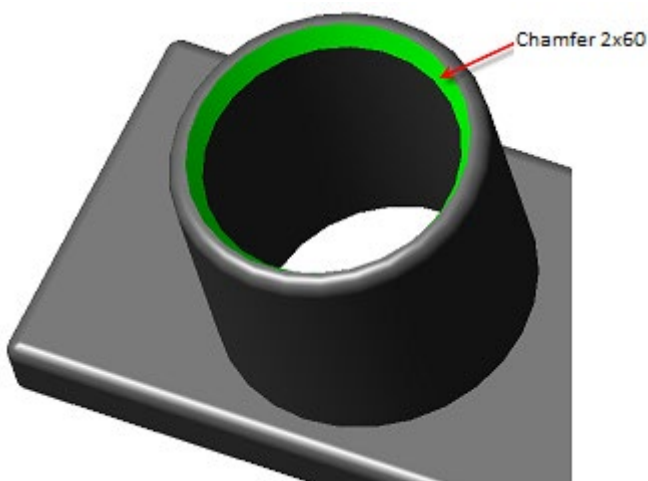

- Select face.
- Determine the method for selecting edges using the switch group "**Edge chain**".
- Select the edges of this face. During the selection process, the chamfering phantoms will be visible in the modeling environment.
- Enter the distance. To the right of the distance input field is the button  "**Measure distance**", allowing to take the value from the drawing.
- Enter the angle. To the right of the distance input field is the button  "**Measure angle**", allowing to take the value from the drawing.

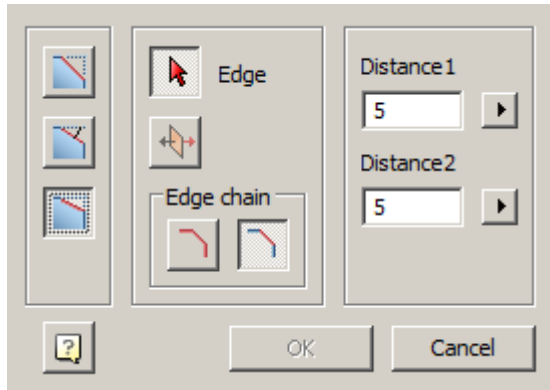

-  **Two distances** -it is possible to construct a facet on two distances from the edge.



- Determine the method for selecting edges using the switch group **"Edge chain"**.
- Select the edges. During the selection process, the chamfering phantoms will be visible in the modeling environment.
- Enter the distances. To the right of the distance input fields are the buttons  **"Measure distance"**, allowing to take the value from the drawing.
- If necessary, invert the distance values using the button  **"Invert values"**.

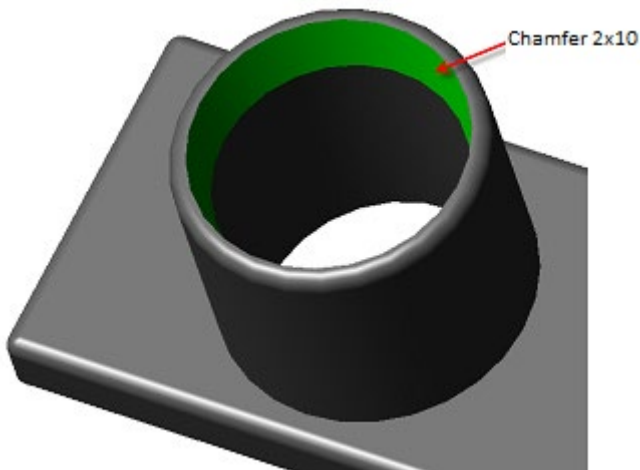

3. Press button **"OK"**. Chamfers will be built. In the **"3D History"** in the part will be an object  **"McChamferFeature"**.

### 3D History

 **"McChamferFeature"**. It is found in the part.

The following shortcut menu commands are available:

- **Edit** - opens the editing dialog **"3D Chamfer"**.
- **Rename (F2)** - allows you to rename a chamfer.
- **Delete (Del)** - removes the chamfer from the tree and model space.
- **Suppress** - removes a chamfer from the model space.
- **Unsuppress** - restores a chamfer in model space.
- **ShowInDocument** - focuses and highlights the chamfer in the center of the model space.
- **Rebuild** - rebuilds an object in model space.

### 3D Thread

 Main menu: **3D - 3D Features -  3D Thread**.

 Ribbon: **3D Tools - Details -  Thread**.



 Toolbar: **3D** -  **3D Thread**.

 Command line: **3DTHREAD**.

The command sets the thread on the selected cylindrical section of the 3D body.

### *Procedure*



1. Call command "**3D Thread**". The "**3D Thread**" dialog will open. When the command is running, the visual style will be set to "**Fast shaded**".

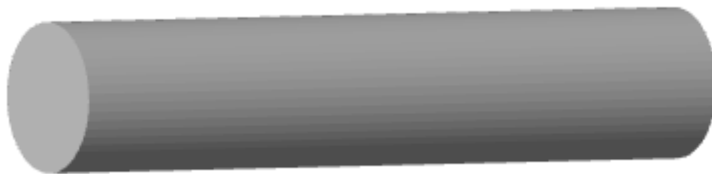

2. Specify "**Thread face**". The face should be cylindrical.

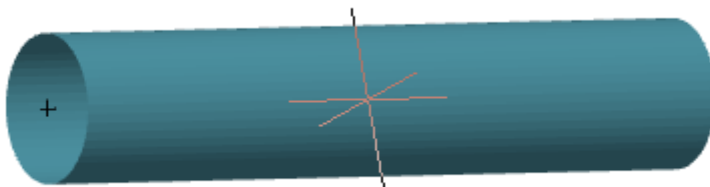

3. Make thread settings in the "**3D Thread**" dialog and click the "**OK**" button.



4. The thread will be built. The visual style will revert to the original. In "**3D History**", a "**Thread**" object is added to the body.

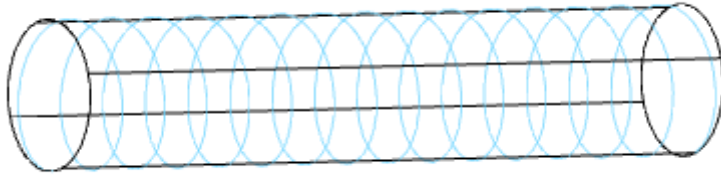

## Edit

Called in the **"3D History"** from the context menu of the **"Thread"** object.

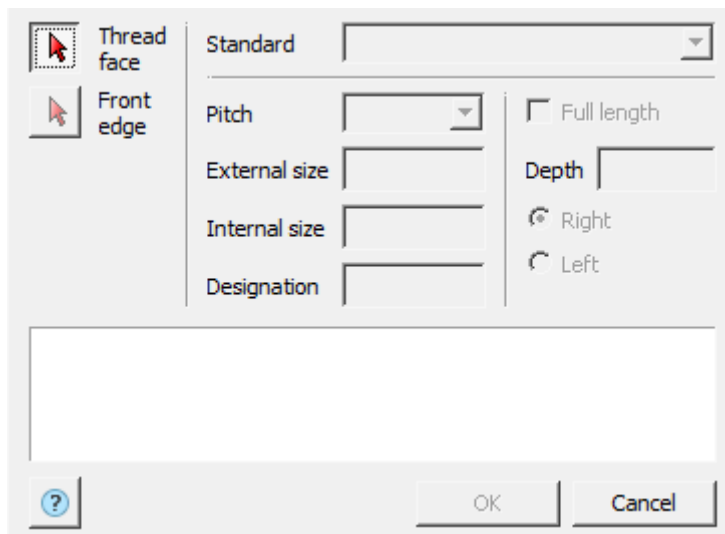

The editing dialog is divided into parts:

- **Face selection panel**

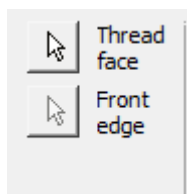

Button **"Thread face"** - allows you to select a cylindrical face to thread onto.

Button **"Front edge"** - allows you to select the thread origin face.

- **Standart**

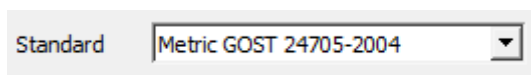

Combobox **"Standart"** - allows you to select the thread standard.

- **Thread Parameter Panel**

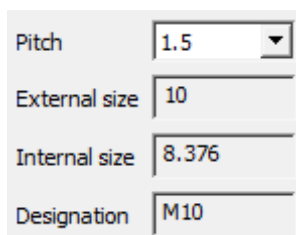

Combobox "**Pitch**" - allows you to select the thread pitch. The list of options depends on the diameter of the cylindrical face and the selected standard.

Field "**External size**" - shows the outer diameter of the thread. The field is not editable.

Field "**Internal size**" - shows the inside diameter of the thread. The field is not editable.

Field "**Designation**" - shows the thread designation. The input field is not editable.

- **Panel for setting thread length and direction**

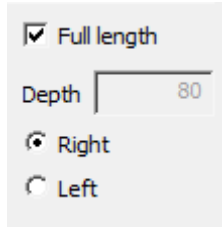

Checkbox "**Full length**" - controls the setting of the thread length. If the switch is on - the length of the thread is determined by the length of the cylindrical face, off - the length of the thread is specified in the "**Depth**" input field.

Field "**Depth**" - specifies the thread length.

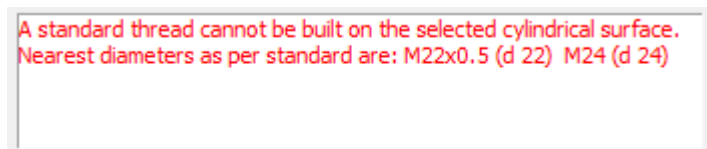

Group switch for thread direction - "**Right**" or "**Left**".

- **Dashboard**



Shows errors and remarks when setting up threads.

## 3D History

 "**Thread**". As part of the  body.

The following context menu commands are available:

- **Edit** - the command opens the thread editing dialog "**3D Thread**".
- **Rename (F2)** - allows you to rename an object.
- **Delete (Del)** - removes object and child objects from tree and model space.
- **Suppress** - removes object and child objects from model space.
- **Unsuppress** - restores the object in model space.
- **ShowInDocument** - focuses and highlights the subject in the center of model space.
- **Rebuild** - rebuilds an object in model space.

## 3D Mirror



Main menu: **3D - 3D Features -  3D Mirror.**



Ribbon: **3D Tools - Solid Editing -  3D Mirror.**



Toolbar: **3D -  3D Mirror.**



Command line: **3DMIRROR.**

Tool for creating a reflection of an element or a body with respect to the plane of reflection. The command works only with parametric solids.

### Procedure

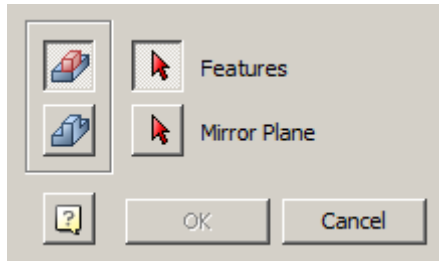

1. Call command  **"3D Mirror"**. Open dialog **"3D Mirror"**.

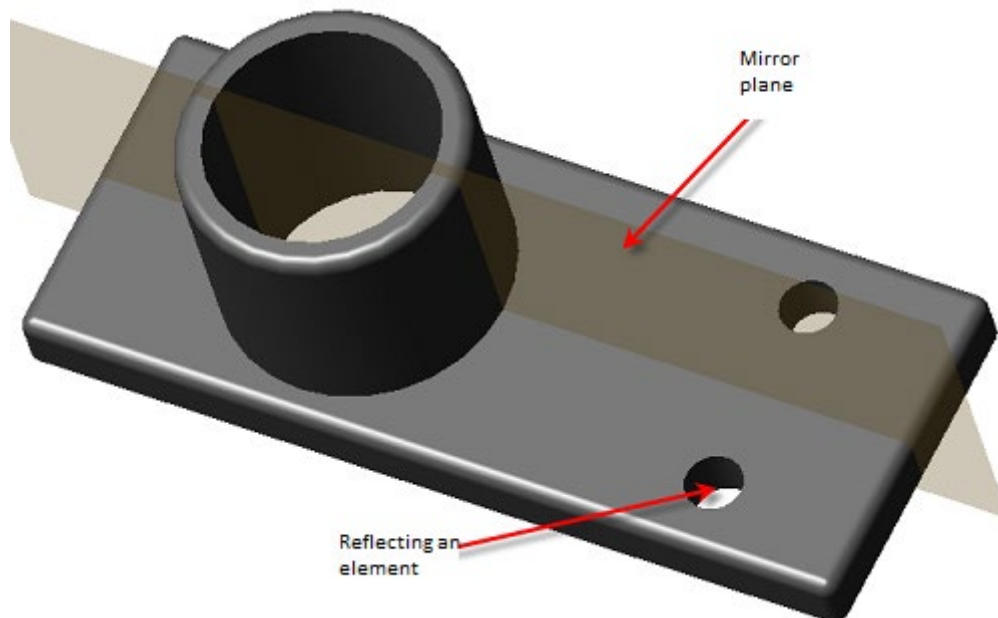

2. In the **"3D Mirror"** dialog, select the type of reflection:

-  Array of features. Reflected body elements and reflection will refer to the original body.



-  Array of bodies. The whole body is reflected, a new body with an element will be created  **"McMirrorFeature"**.

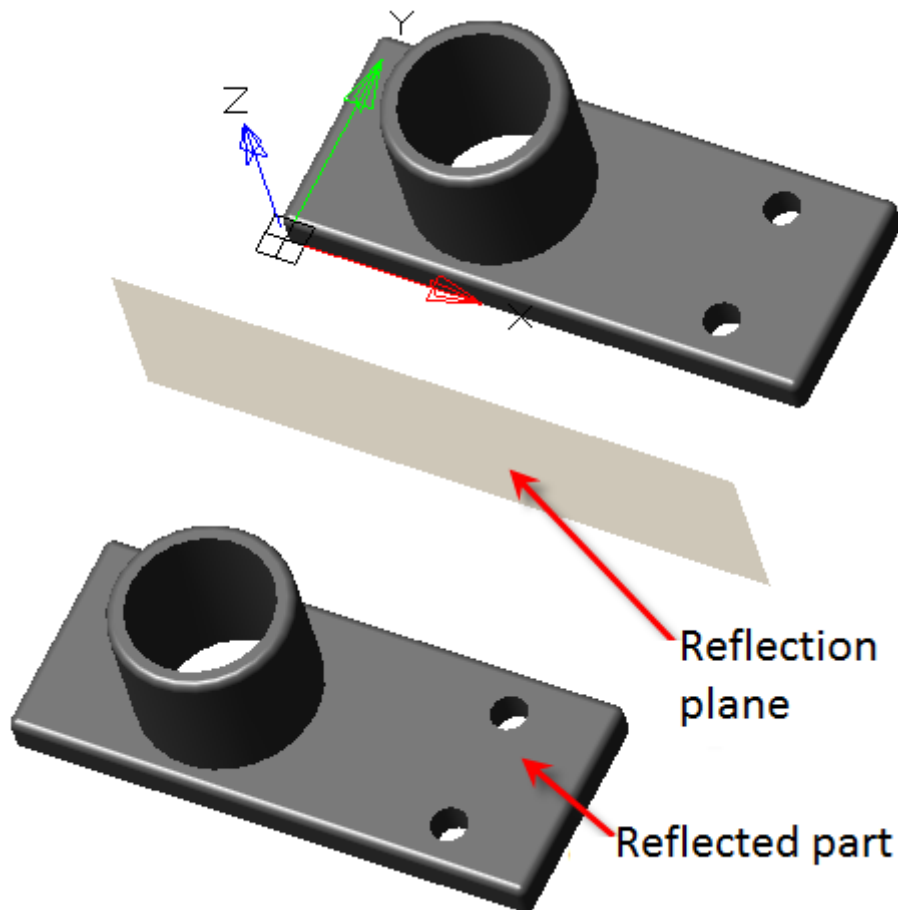







3. Select elements or body, depending on the type of reflection selected.

4. Select the reflection plane. It can be the plane of the coordinate system, the working plane or the face of any body. When selecting a reflection plane, a phantom reflective appears.

5. Press button **"OK"**. Reflection will be created based on the selected items. In the **"3D History"** an object appears  **"McMirrorFeature"**.

### 3D History

 **"McMirrorFeature"**. It is part of the body. When the elements of the original body are reflected, the object  **"McMirrorFeature"** falls into the composition of the original body. When the original body is reflected, a new body, object  **"McMirrorFeature"** falls into the new body.

The object  **"McMirrorFeature"** includes: folder  **"Elements"** with a list of source elements or folder  **"Solids"** with a list of source bodies, and two links  **"Occurrences"**, showing in the model space the finding of the original elements and reflected.

The following commands of the object's context menu are available  **"McMirrorFeature"**:

- **Edit** - opens the editing dialog **"3D Mirror"**.
- **Rename (F2)** - allows you to rename an object.
- **Delete (Del)** - removes an object from the tree and model space.
- **Suppress** - removes the mirrored object from the model space.
- **Unsuppress** - restores a mirrored object in model space.
- **ShowInDocument** - focuses and highlights the mirrored object in the center of model space.
- **Rebuild** - rebuilds an object in model space.

## Union

 Ribbon: **3D Tools - Solid Editing - Union**.

 Toolbar: **3D - Union**.

 Command line: **UNION**.

The tool allows you to combine parametric objects or 3D solidities.

### Procedure

1. Call command **Union**;
2. Specify the merge objects;

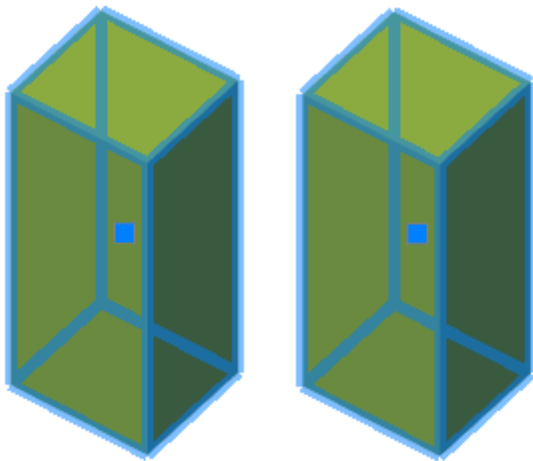

3. Press the **"Enter (Space)"** key;
4. Union will be made. All selected objects become one object. In **"3D History"**, the first selected body will display an object **Union**, containing all selected bodies except the first.

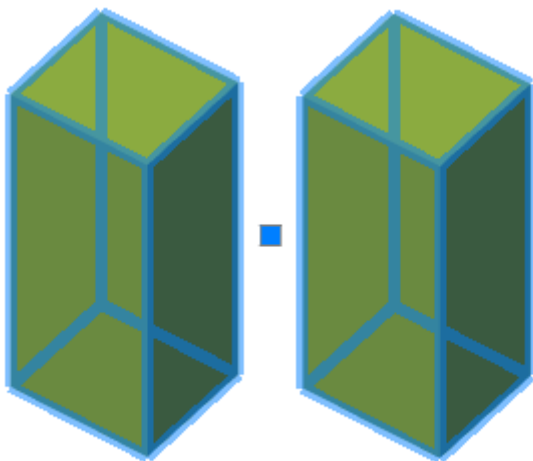

**Note:**

If the objects were selected before the **"Union"** command is called, the union will be automatically generated immediately after the call.

### 3D History

①**"Union"**. It is part of the parent part, contains parts that are combined with the parent part.

The following shortcut menu commands are available:

- **Rename (F2)** - allows you to rename an association.
- **Delete (Del)** - removes the union and its associated objects from the tree and model space.
- **Suppress** - suppresses the union. With the parts included in the union, you can treat as individual objects.
- **Unsuppress** - restores the union.
- **ShowInDocument** - focuses and highlights the incoming bodies in the center of model space.
- **Rebuild** - rebuilds an object in model space.

### Intersect



Ribbon: **3D Tools - Solid Editing - ①Intersect**.



Toolbar: **3D - ①Intersect**.



Command line: **INTERSECT**.

The tool allows you to create an object based on the intersection of several objects. That is, the new object will be the joint intersected area.

### Procedure

1. Call command ①**"Intersect"**;
2. Specify intersecting objects;

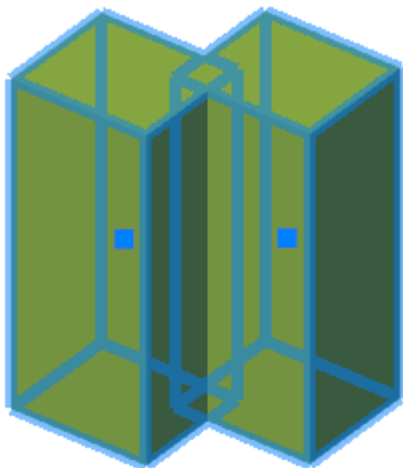

3. Press the **"Enter (Space)"** key;

4. A new object based on the intersection will be created. In **"3D History"**, the first selected body will display an object **"Intersect"**, containing all selected bodies except the first.



**Note:** If the objects were selected before the **"Intersect"** command is called, the intersection will be automatically generated immediately after the call.

### *3D History*

**"Intersect"**. It is part of the parent part, contains parts that intersect with the parent part.

The following shortcut menu commands are available:

- **Rename (F2)** - allows you to rename an intersection.
- **Delete (Del)** - removes the intersection and associated objects from the tree and model space.
- **Suppress** - suppresses the intersection action. With bodies entering the intersection, you can treat both as individual objects.
- **Unsuppress** - restores the intersection action.
- **ShowInDocument** - focuses and highlights the faces obtained as a result of the intersection, in the center of the model space.
- **Rebuild** - rebuilds an object in model space.

### *Subtract*



Ribbon: **3D Tools - Solid Editing** - **Subtraction**.



Toolbar: **3D** - **Subtract**.



Command line: **SUBTRACT**.

The tool allows you to create an object based on the selected objects by subtracting one of the others (the objects are divided into those from which the subtraction will be made and those that will subtract).

### *Procedure*

1. Call command **"Subtract"**;



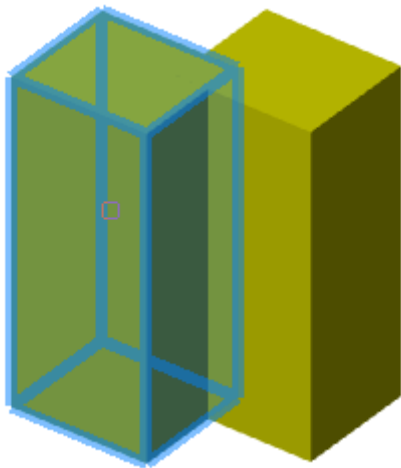

2. Specify the objects from which the subtraction will be made;

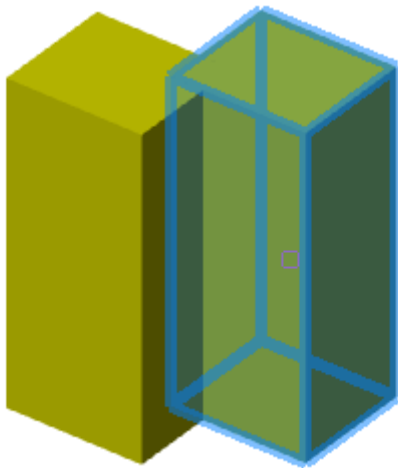

3. Specify the objects that will be subtracted;



4. Press the **"Enter (Space)"** key;

5. A new object will be created. If the number of bodies from which a subtraction of more than one was made, then in **"3D History"** in the first subtrahend body appears object  **"Subtract"**, containing all subtrahend bodies except the first. In the same body, an object will appear  **"Intersect"**, containing all subtractive bodies.



**Note:**

If the objects from which the subtraction will be made were selected before the "**Subtract**" command is called, then the command immediately proceeds to the selection of subtracting objects.

### 3D History

 "**Subtract**". It is part of the parent body, contains bodies that are subtracted from the parent.

The following shortcut menu commands are available:

- **Rename (F2)** - allows you to rename subtraction.
- **Delete (Del)** - removes subtraction and related objects from the tree and model space.
- **Suppress** - suppresses the subtraction action. With the parts included in the subtraction, one can treat both as individual objects.
- **Unsuppress** - restores the subtraction action.
- **ShowInDocument** - focuses and highlights the edges obtained as a result of subtraction, in the center of the model space.
- **Rebuild** - rebuilds an object in model space.

### Add work plane



Main menu: **3D - 3D Features** -  **Add work plane**.



Ribbon: **3D Tools - Solid Editing** -  **Add work plane**.



Toolbar: **3D** -  **Add work plane**.



Command line: **ADDWPL**.

A tool that allows you to add a new plane to the model space.

### Procedure

1. Call command  "**Add work plane**".
2. Choose how to build a plane from the context menu or command line:

- **select object** - the construction of a plane by choosing a face or a part edge.
- **3PT** - plane construction by three points.
- **2LN** - the construction of a plane along two axes (segments can also be axes for constructing a plane).
- **WPL\_NORM2CURV** - the construction of the plane is normal to the curve. To build, you must specify a curve and a point.
- **WPL\_NORM2SURF** - the construction of a plane normal to the surface. To build, you must specify a surface and a point.
- **LPANG** - the construction of the plane along the axis, plane and angle. The angle is measured from the selected plane counterclockwise.
- **PLOFS** - plot the plane at a distance from the selected one.

3. Select the required objects according to the chosen method of plotting the plane. To facilitate the selection of "the main coordinate system selection items", commands will be available in the context menu:

- **Origin** - Selects the point of intersection of the main axes of coordinates.
- **X, Y, Z** - Selects axes of the main coordinate system.
- **XY, YZ, ZX** - Selects the planes of the main coordinate system.

4. The "**Work Plane**" object will be created and added to "**3D History**".



### Properties

Does not have individual properties.

### Grips

■ **Moving grip** - serves to move the plane in the model space. It is recommended not to use.

### 3D History

 Work plane. Can be located in the root of the tree and enter the structure of objects  
 "**Part**".

The following shortcut menu commands are available:

- **Rename (F2)** - allows you to rename a plane.
- **Delete (Del)** - removes the plane and related objects from the tree and model space.
- **Create 2d-sketch** - calls the command ["Add planar sketch"](#). The drawing sketch plane is not necessary.
- **Hide** - hides the mapping of the plane in model space.
- **Show** - shows the mapping of the plane in model space.
- **Fix** - fixes a plane in model space. An anchor label is added to the plane icon. The command is available if the plane does not belong to the body.
- **Unfix** - Defines a plane in model space. The command is available if the plane does not belong to the body.
- **ShowInDocument** - focuses the plane in the center of the model space. The command is available when the plane is displayed.
- **Rebuild** - rebuilds the object in model space.

### Add work axis



Main menu: **3D - 3D Features** -  **Add work axis**.



Ribbon: **3D Tools - Solid Editing** -  **Add work axis**.

 Toolbar: **3D** -  **Add work axis**.

 Command line: **ADDWA**.

A tool that allows you to add a new axis to the model space.

### Procedure

1. Call command  **"Add work axis"**.
2. Choose how to draw an axis from the context menu or command line:
  - **select object** - the construction of the plane by the choice of the edge of the part.
  - **2PT** - plane construction by two points.
  - **AXIS** - the construction of an axis along a segment: edges, axes of symmetry, free geometry.
  - **2PLN** - the construction of an axis on the line of intersection of two planes.
  - **WA\_NORM2CURV** - the construction of the axis is normal to the curve. To build, you must specify a curve and a point.
  - **WA\_NORM2SURF** - the construction of an axis normal to the surface. To build, you must specify a surface and a point.
3. Select the required objects according to the selected axis construction method. To facilitate the selection of **"the main coordinate system selection items"**, commands will be available in the context menu:
  - **Origin** - Selects the point of intersection of the principal axes of coordinates.
  - **X, Y, Z** - Selects axes of the main coordinate system.
  - **XY, YZ, ZX** - Selects the planes of the main coordinate system.
4. The **"Work axis"** object will be created and added to **"3D History"**.



### Properties

Does not have individual properties.

### Grips

 **Moving grip** - serves to move the axis in the model space. If the axis belongs to the body, it moves with it.

### 3D History

 Work axis. It can be located in the root of the tree and be part of objects  **"Part"**.

The following shortcut menu commands are available:

- **Rename (F2)** - allows you to rename an axis.
- **Delete (Del)** - removes the axis and related objects from the tree and model space.
- **Hide** - hides the axis map in model space.
- **Show** - shows the display of the axis in model space.
- **Fix** - fixes the axis in the model space. An anchor label is added to the axis icon. The command is available if the axis does not belong to the body.
- **Unfix** - Defines an axis in model space. The command is available if the axis does not belong to the body.
- **ShowInDocument** - focuses the axis in the center of the model space. The command is available when the axis is displayed.
- **Rebuild** - rebuilds the object in model space.

## Add work point



Main menu: **3D - 3D Features** -  **Add work point**.



Ribbon: **3D Tools - Solid Editing** -  **Add work point**.



Toolbar: **3D** -  **Add work point**.



Command line: **ADDWPT**.

A tool that allows you to add a new point to the model space.

### Procedure

1. Call command  **"Add work point"**.
2. Choose how to build a point from the context menu or command line:
  - **select object** - the construction of a working point by choosing a point of the part.
  - **VERTEX** - the construction of a point along the existing working point, the vertex of the body, the middle of the part's rib, the characteristic points of free geometry, and so on.
  - **CENTER** - construction of the point at the central point of the element.
  - **2CRV** - the construction of a point at the intersection of two curves.
  - **CRVSURF** - the construction of a point in the intersection of a curve and a surface.
  - **3PLN** - the construction of a point in the intersection of three planes.
3. Select the required objects according to the selected way of constructing the point. To facilitate the selection of the **"main coordinate system selection items"**, the following commands will be available in the context menu:
  - **Origin** - Selects the point of intersection of the principal axes of coordinates.
  - **X, Y, Z** - Selects axes of the main coordinate system.
  - **XY, YZ, ZX** - Selects the planes of the main coordinate system.
4. The **"Work point"** object will be created and added to **"3D History"**.



### Properties

Does not have individual properties.

### Grips

 **Moving grip** - serves to move a point in the model space. If the point belongs to the part, it moves with it.

### 3D History

 Work point. Can be located in the root of the tree and enter the structure of objects  **"Part"**.

The following shortcut menu commands are available:

- **Rename (F2)** - allows you to rename a point.
- **Delete (Del)** - removes a point and related objects from the tree and model space.
- **Hide** - hides the display of a point in the model space.
- **Show** - shows the display of a point in the model space.

- **Fix** - fixes a point in the model space. An anchor label is added to the point icon. The command is available if the point does not belong to the part.
- **Unfix** - defixes a point in model space. The command is available if the point does not belong to the part.
- **ShowInDocument** - focuses the point in the center of the model space. The command is available when the point is displayed.
- **Rebuild** - rebuilds an object in model space.

## 3D Constraint

### Mate 3D Constraint

**Important!** To use this functionality, the 3D modeling engine C3D is required.

 Main menu: **3D - 3D Features -  Mate 3D Constraint.**

 Ribbon: **3D Tools - 3D Constraint -  Mate 3D Constraint.**

 Toolbar: **3D -  Mate 3D Constraint.**

 Command line: **3DMATE.**

The command allows you to impose a 3D constraint "**Mate**" on objects.

#### Procedure

1. Call command  "**Mate 3D Constraint**";

**Important!** When applying a constraint, at least one solid must be unfixed.

2. Select the geometry of the first solid (plane, edge, or point);

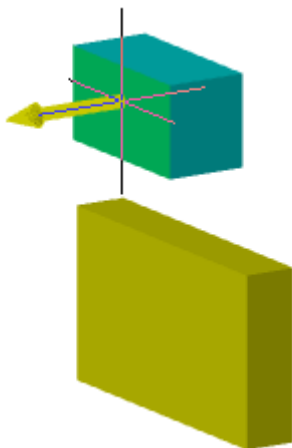

3. Select the geometry of the second solid (plane, edge, or point);

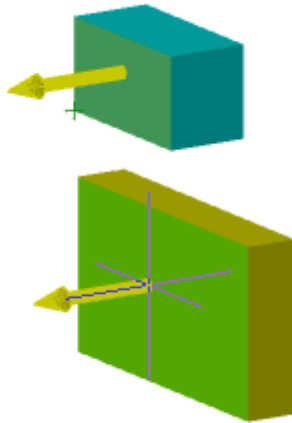

**Note:**

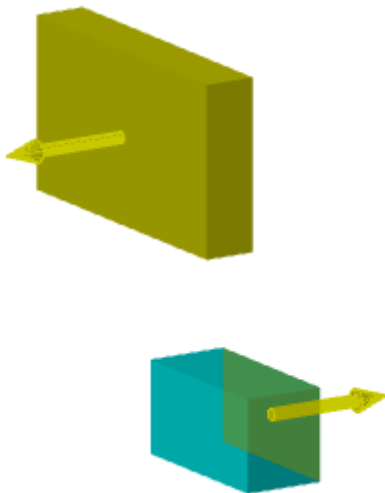

Alignment is performed along the normals of the selected geometry. When you select a plane, the normal is perpendicular to the plane. When you select an edge, the normal is along the edge. When you select a point, the normal is along the Z axis.

4. Enter the distance between the first or second geometry or select the **"Flush"** context menu command (for planes only);



5. Constraint is applied, and  **"Mate constraint"** objects are added to the **"3D History"** for each participating solid.

**Edit**

 **"Mate constraint"**. As part of the  body.

The following context menu commands are available:

- **Edit** - causes constraint to be edited.
- **End edit** - completes the previously started editing.
- **Rename (F2)** - allows you to rename the constraint.
- **Delete (Del)** - delete constraint.

## Insert 3D Constraint

**Important!** To use this functionality, the 3D modeling engine C3D is required.

 Main menu: **3D - 3D Features -  Insert 3D Constraint.**

 Ribbon: **3D Tools - 3D Constraint -  Insert 3D Constraint.**

 Toolbar: **3D -  Insert 3D Constraint.**

 Command line: **3DINSERT.**

The command allows you to impose a 3D constraint "**Insert**" on objects.

### Procedure

1. Call command  "**Insert 3D Constraint**";

**Important!** When applying a constraint, at least one body must be unfixed.

2. Select the edge of the first body (circle, arc);

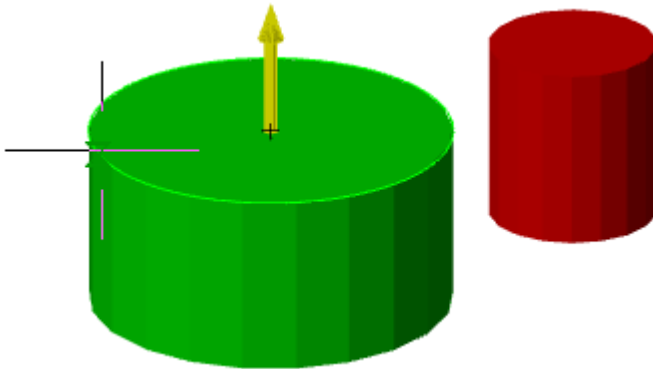

**Important!** A spline can be mistaken for a circle. Such a situation may arise, for example, when the edge of the hole is on a curved (cylindrical) plane.

3. Select the edge of the second body (circle, arc);



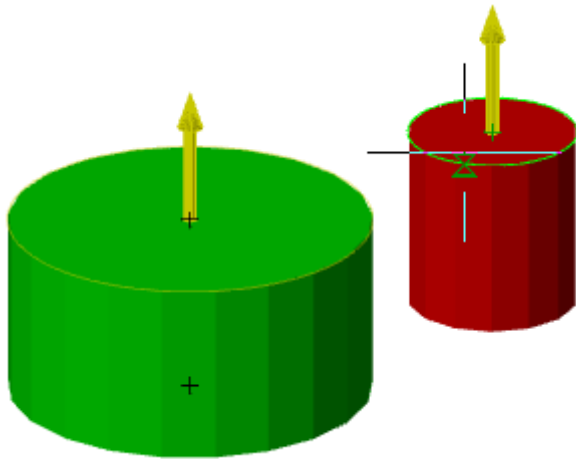

**Important!**

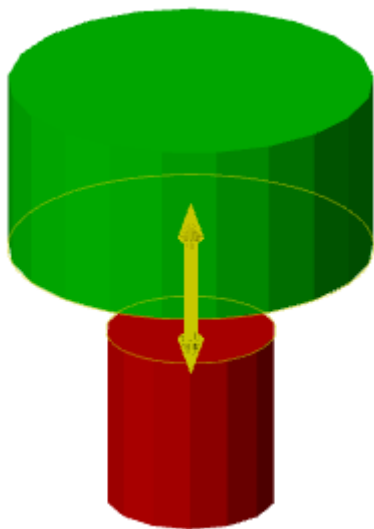

A spline can be mistaken for a circle. Such a situation may arise, for example, when the edge of the hole is on a curved (cylindrical) plane.

4. Enter the distance between the first or second geometry or select the **"Co-Directional"** context menu command;



5. Constraint is applied, and  **"Insert constraint"** objects are added to the **"3D History"** for each participating solid.

**Edit**

 **"Insert constraint"**. As part of the  body.

The following context menu commands are available:

- **Edit** - causes constraint to be edited.
- **End edit** - completes the previously started editing.
- **Rename (F2)** - allows you to rename the constraint.
- **Delete (Del)** - delete constraint.

## Angle 3D Constraint

**Important!** To use this functionality, the 3D modeling engine C3D is required.

 Main menu: **3D - 3D Features -  Angle 3D Constraint.**

 Ribbon: **3D Tools - 3D Constraint -  Angle 3D Constraint.**

 Toolbar: **3D -  Angle 3D Constraint.**

 Command line: **3DANGLE.**

The command allows you to impose a 3D constraint "**Angle**" on objects.

### Procedure

1. Call command  "**Angle 3D Constraint**";

**Important!** When applying a constraint, at least one body must be unfixed.

2. Select the geometry of the first body (plane or edge);



3. Select the geometry of the second body (plane or edge);

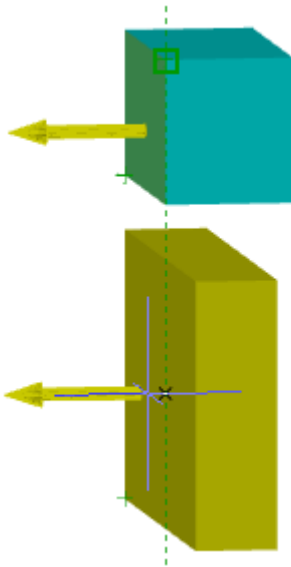

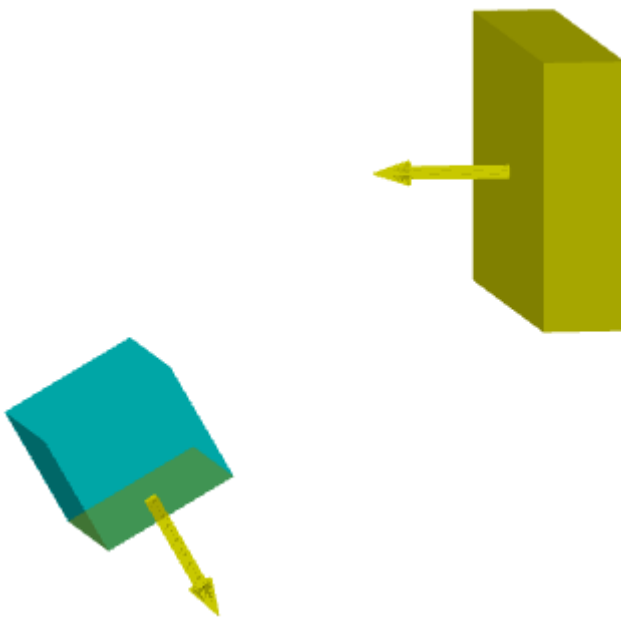

4. Select "**Axis of rotation**" if necessary. When specifying an angle between two primitives, the default angle scheme is used in the range 0-180. In order to cover the entire range of angles, an axis of rotation is needed. Also, setting the axis allows you to more correctly determine the direction of rotation. The axis must be perpendicular to both directions;

5. Enter the angle in degrees between the first or second geometry;



6. Constraint is applied, and  "**Angle constraint**" objects are added to the "**3D History**" for each participating solid.

### *Edit*

 "**Angle constraint**". As part of the  body.

The following context menu commands are available:

- **Edit** - causes constraint to be edited.
- **End edit** - completes the previously started editing.
- **Rename (F2)** - allows you to rename the constraint.
- **Delete (Del)** - delete constraint.

## Tangent 3D Constraint

**Important!** This functionality requires a C3D 3D modeling engine.



Main menu: **3D - 3D Features -  Tangent 3D Constraint.**



Ribbon: **3D Tools - 3D Constraint -  Tangent 3D Constraint.**



Toolbar: **3D -  Tangent 3D Constraint.**



Command line: **3DTANGENT.**

The command allows you to impose a 3D constraint "**Tangent**" on objects.

The Tangent 3D constraint allows you to create more complex surface tangencies than the Mate 3D constraint.

Constraint is superimposed on:

- cylinder to plane;
- cylinder to cylinder;
- cone to plane;
- sphere to cylinder;
- sphere to plane;
- circular edge to straight edge;
- circular edge to circular edge.

### Procedure

1. Call command  "**Tangent 3D Constraint**";

**Important!** When applying a constraint, at least one body must be unfixed.

2. Select the geometry of the first solid;

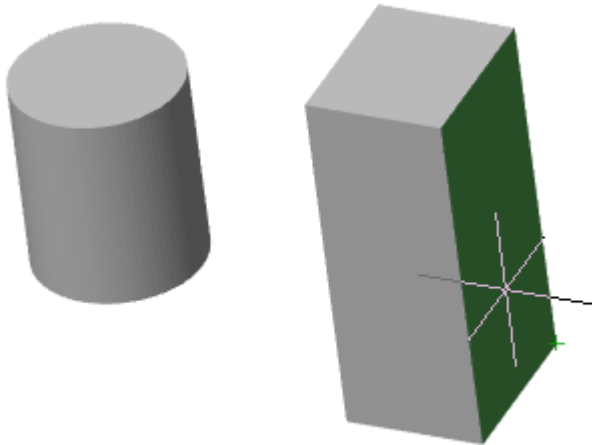

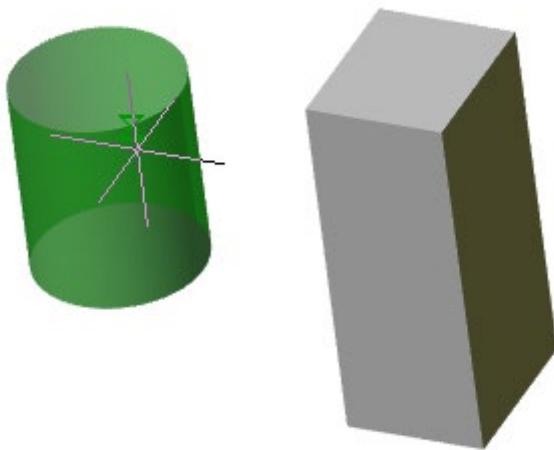

3. Select the geometry of the second body;

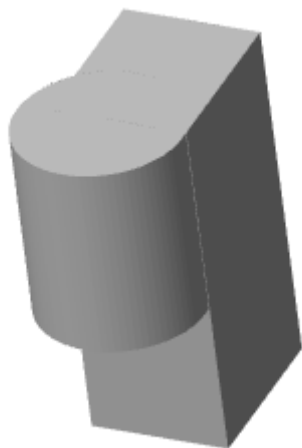

4. Constraint is applied, and  **"Tangent constraint"** objects are added to the **"3D History"** for each participating solid.



## Edit

 **"Tangent constraint"**. As part of the  body.

The following context menu commands are available:

- **Edit** - causes constraint to be edited.
- **End edit** - completes the previously started editing.
- **Rename (F2)** - allows you to rename the constraint.
- **Delete (Del)** - delete constraint.

## Symmetry 3D Constraint

### Important!

This functionality requires a C3D 3D modeling engine.



Main menu: **3D - 3D Features -  Symmetry 3D Constraint.**



Ribbon: **3D Tools - 3D Constraint -  Symmetry 3D Constraint.**



Toolbar: **3D -  Symmetry 3D Constraint.**



Command line: **3DSYMMETRY.**

The command allows you to impose a 3D constraint **"Symmetry"** on objects.

The Symmetry 3D constraint allows you to align 3D solid elements symmetrically about a selected plane.

## Procedure

1. Prepare objects: two symmetry objects and a plane. A face of a solid can be used as a plane.

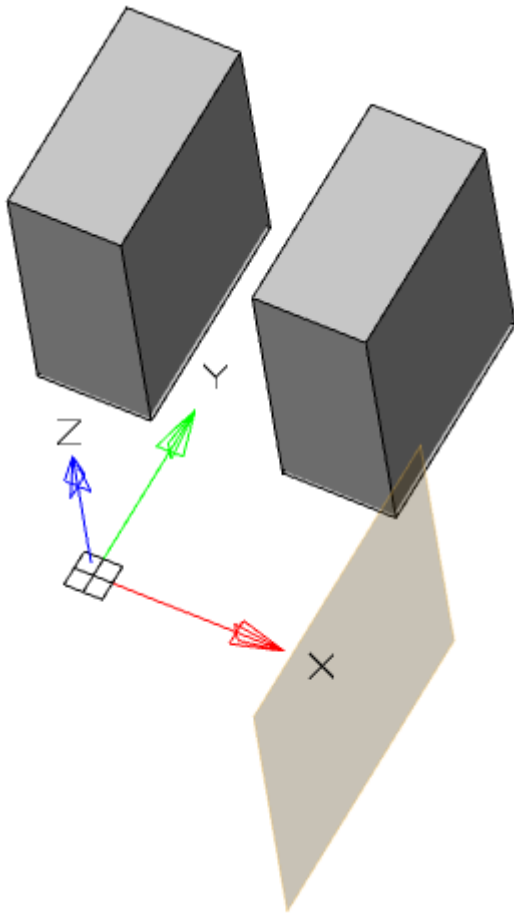

2. Call command  **"Symmetry 3D Constraint"**.

**Important!**

When applying a constraint, at least one body must be unfixed.

3. Select the plane of the first solid.

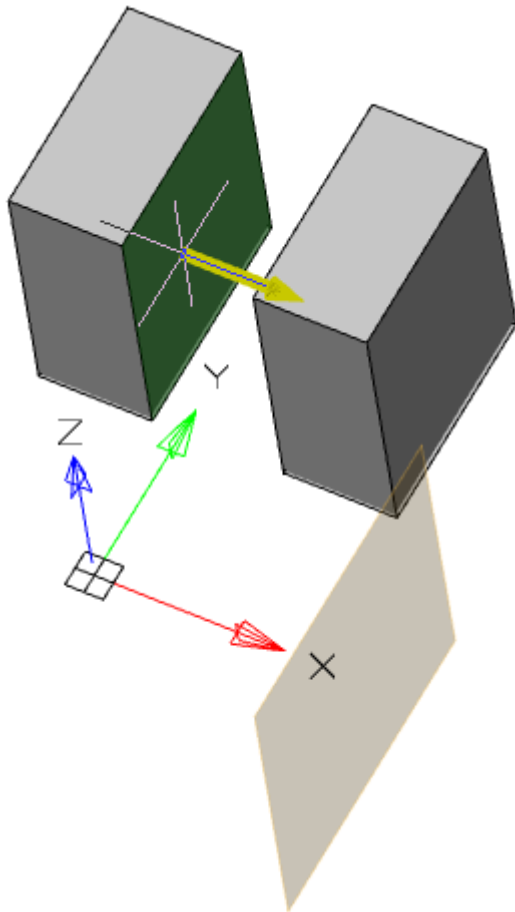

4. Select the plane of the second solid.

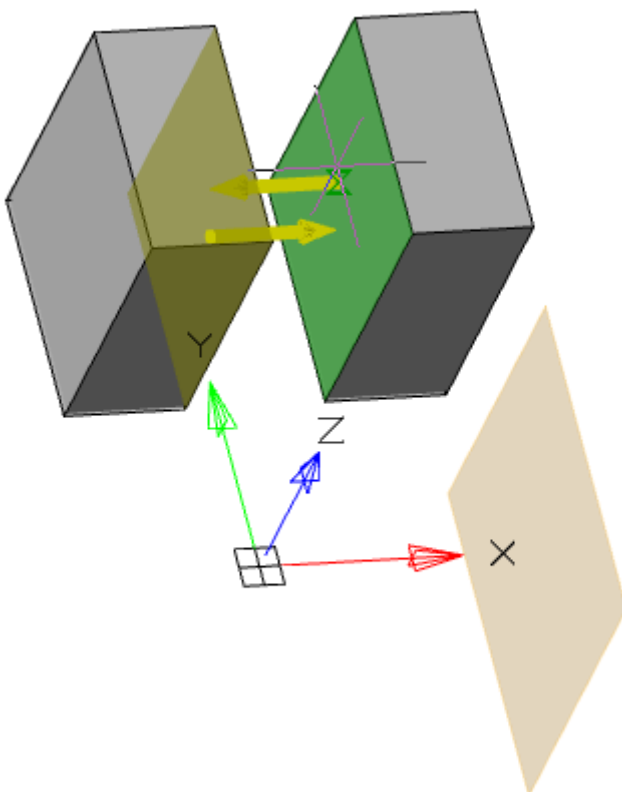



5. Select the plane relative to which the objects will be symmetrically positioned.

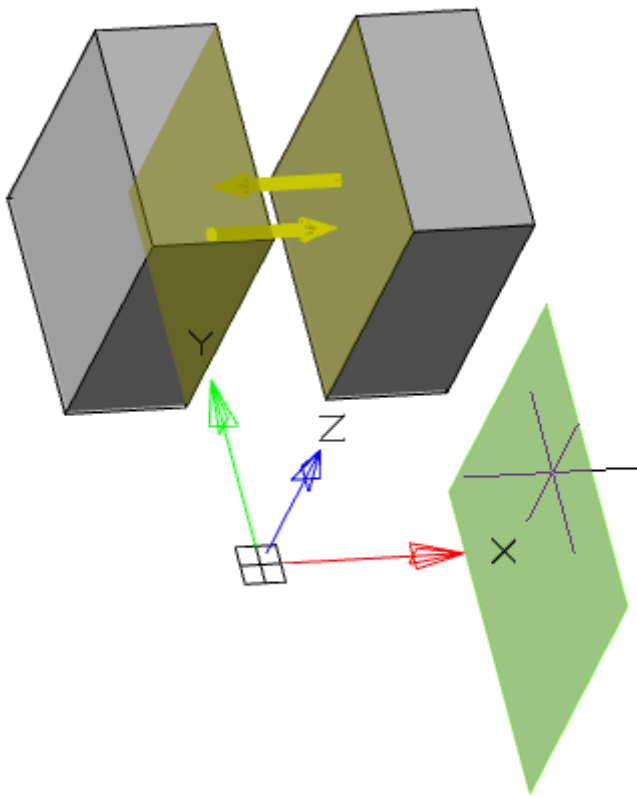

6. Constraint is applied, and  **"Symmetry constraint"** objects are added to the **"3D History"** for each participating solid.

The distance from the first selected face to the plane will be the base for the second selected face.

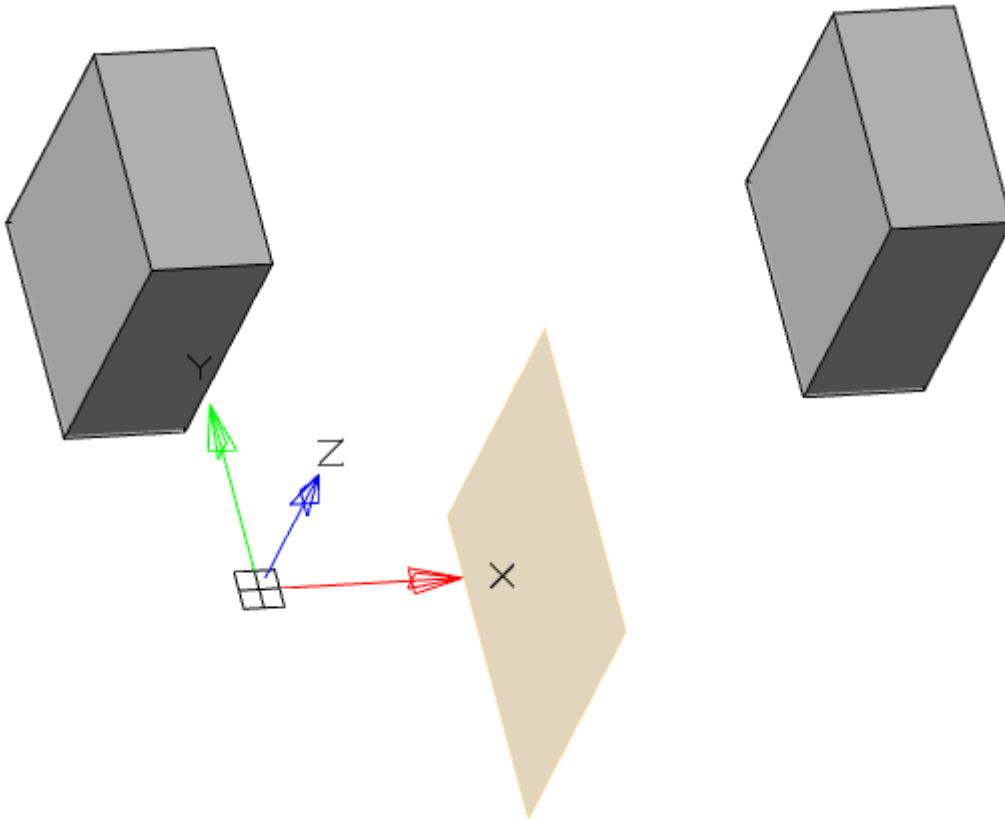

## Edit

 **"Symmetry constraint"**. As part of the  body.

The following context menu commands are available:

- **Edit** - causes constraint to be edited.
- **End edit** - completes the previously started editing.
- **Rename (F2)** - allows you to rename the constraint.
- **Delete (Del)** - delete constraint.

## Converts

### Convert to Mesh



Main menu: **3D -  Convert to Mesh.**



Ribbon: **3D Tools - Transform -  Convert to Mesh.**



Toolbar: **3D -  Convert to Mesh.**



Command line: **MESHSMOOTH.**

The tool allows you to convert **"Parametric solid"** (3D) and **"3D Solid"** in the object **"Polyface Mesh"**.

## Procedure

1. Call command  **"Convert to Mesh"**;
2. Specify the objects that need to be converted;

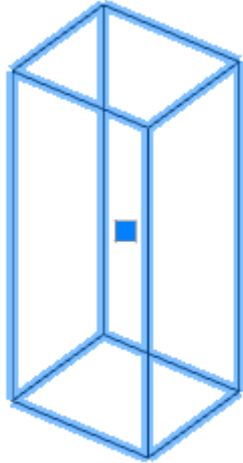

3. Press the key **"Enter (Space)"**;
4. Objects will be converted.

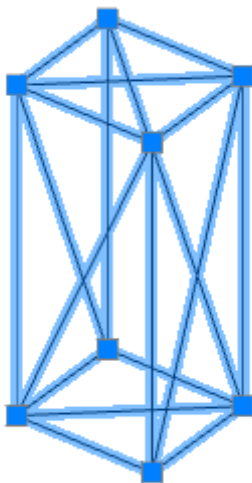

### Note:

If the objects were selected before the command **"Convert to Mesh"** is called, the conversion will be performed automatically immediately after the command is called.

## Convert to Solid



Main menu: **3D** -  **Convert to Solid**.



Ribbon: **3D Tools - Transform** -  **Convert to Solid**.

 Toolbar: **3D -  Convert to Solid**.

 Command line: **CONVTOSOLID**.

The tool allows you to convert an object "**Polyface Mesh**" in the object "**3D Solid**".

### *Procedure*

1. Call command  "**Convert to Solid**";
2. Specify the objects that need to be converted;

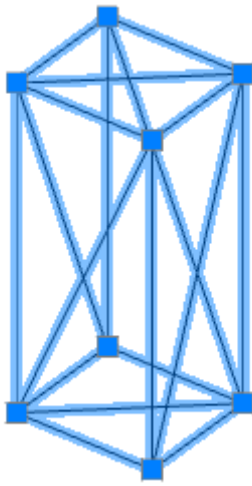

3. Press the key "**Enter (Space)**";
4. Objects will be converted.

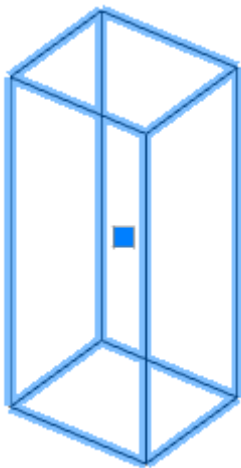

#### **Note:**

If the objects were selected before the command "**Convert to solid**" is called, the conversion will be performed automatically immediately after the command is called.

## 2D Views

Toolbar for creating flat views and cuts from a 3D model.



By default, views are placed on the plane XoY.

**Note:**

It is recommended to place views in the main coordinate system in order to avoid possible problems with the display of annotations.

By default, global settings are used when inserting new views. Changes in global settings made after inserting a new view will be reflected in this view.

If you change any view parameter, this parameter will be unsettled from global settings and further changes of this parameter in global settings will not affect this view.

To remove the parameter override, use the command - Redefinition parameters.

### Section Plane



Main menu: **3D - 2D Views - Section**.



Ribbon: **3D Tools - Section - Section Plane**.



Toolbar: **2D Views - Section**.



Command line: **VIEWSECTION**.

The team is designed to get a flat section of the body.

### Procedure

1. Call command **Section Plane**.
2. Select the cutting plane:
  - The secant plane can be any plane (working, plane GCS), as well as a flat surface of the solid.

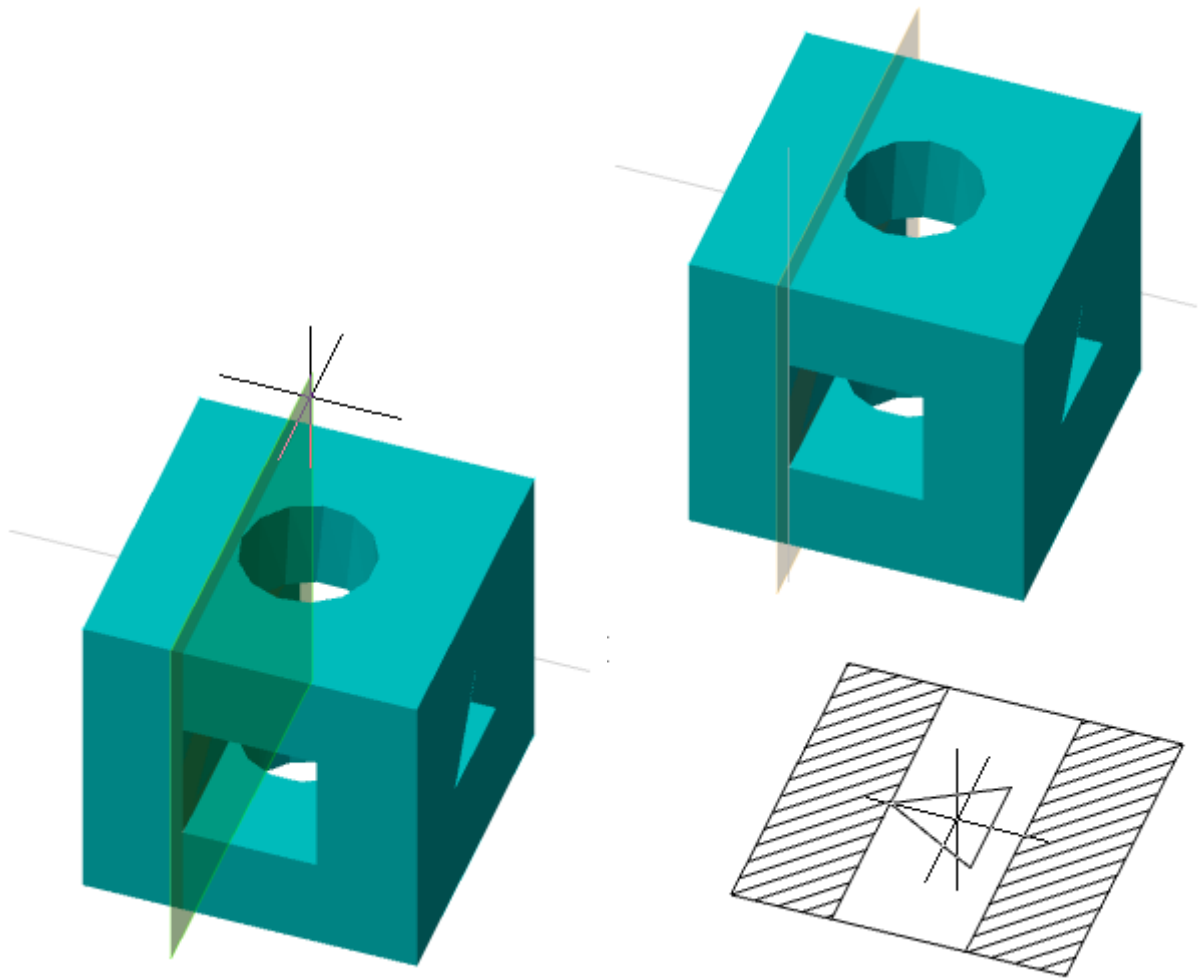

- A plane section can also be obtained by dissecting the solid not by a plane, but by a line. To do this, you must specify two points that will indicate the direction of the plane. If the cutting plane is indicated by a line, the plane will always be perpendicular to the XY plane.

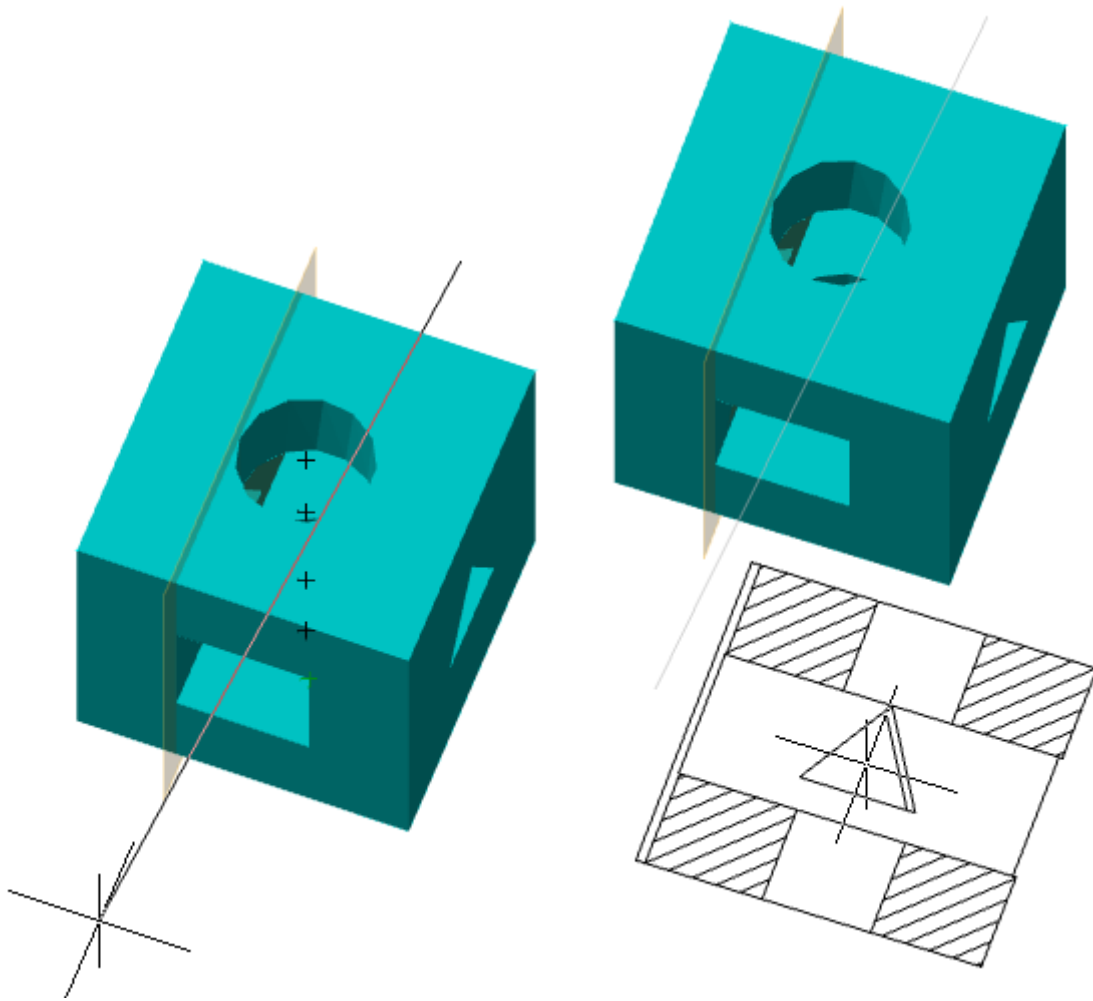

- A flat section can be obtained by indicating three points. To do this, select the command "**3Points**" from the context menu and select 3 points.

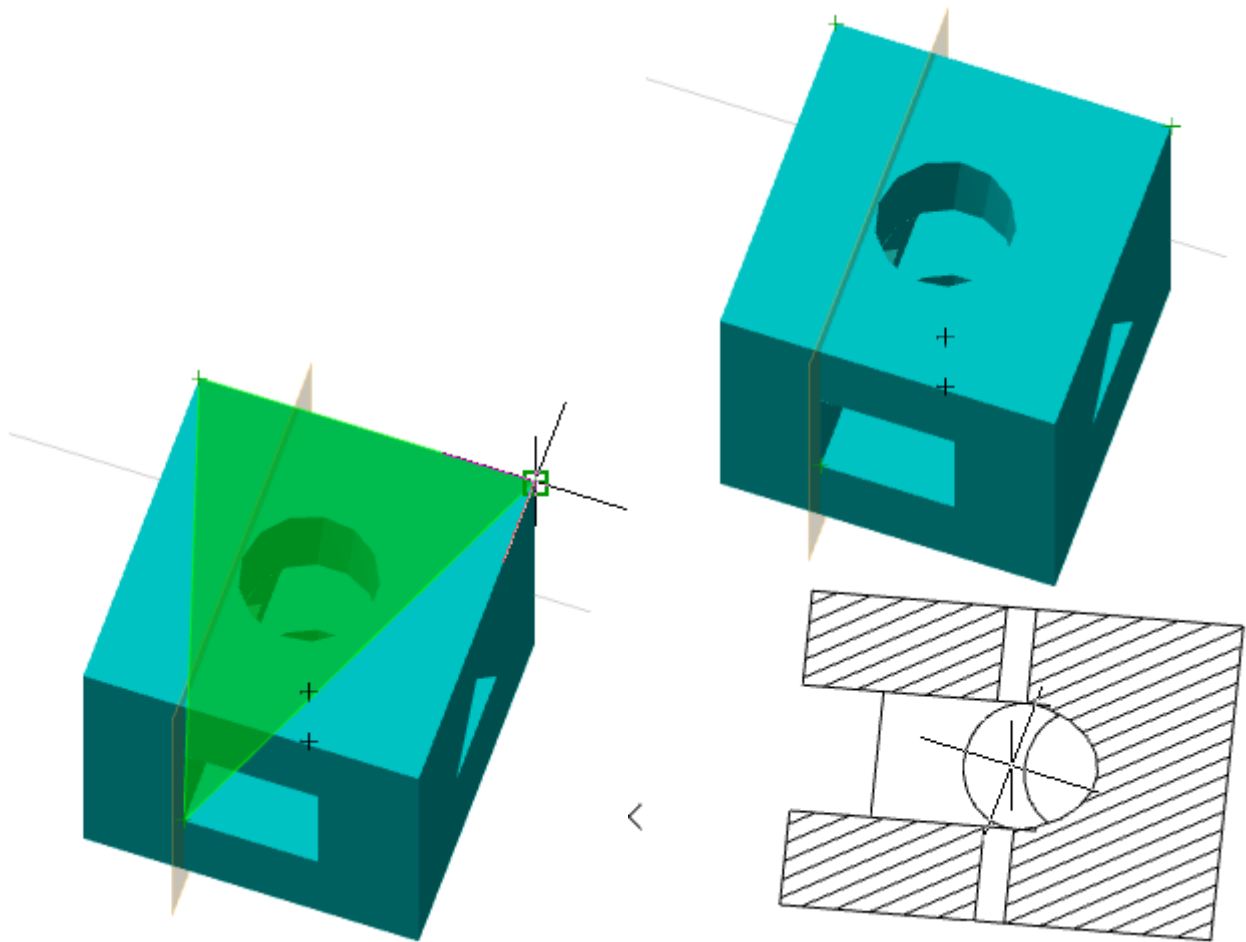

3. Specify the sheet where the view will be located. The command will offer a choice of all the sheets and model space that are in the document.

4. Select the position of the main planar section view. The view on the sheet is scaled so that it enters the sheet space and still has room for auxiliary projections.



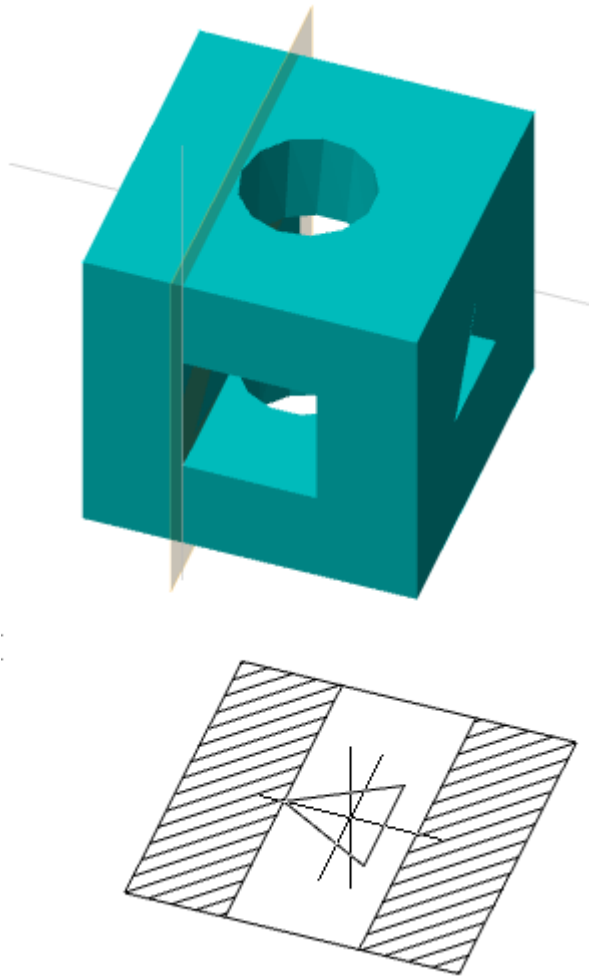

5. Insert projected section views. Press the **"Enter"** key to finish inserting projection views. Auxiliary projections are inserted on the same sheet where the main view is inserted.

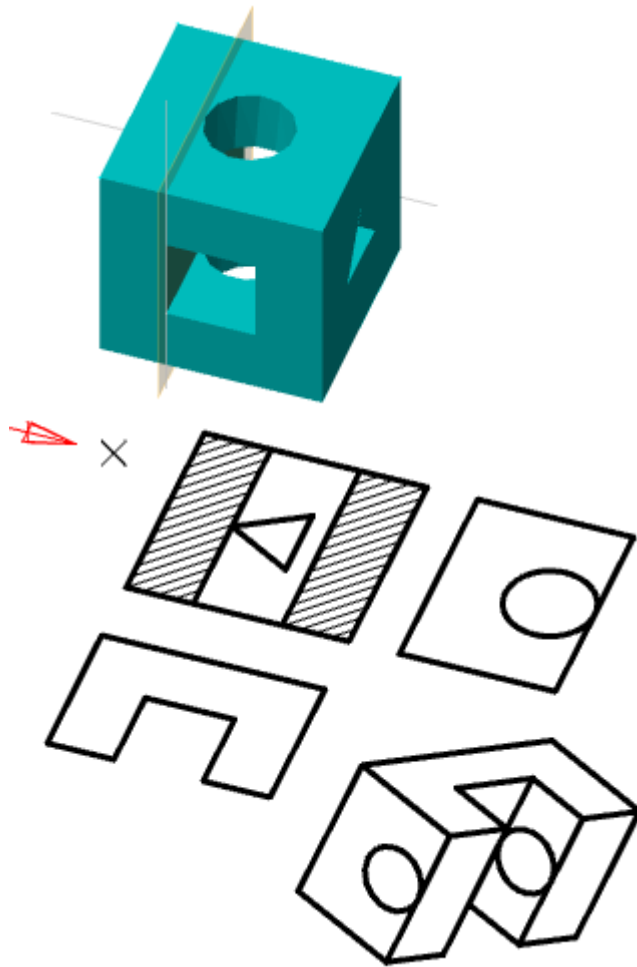

6. Will be built "**NcDbSection**" and "**DrwingViewBlock**". The corresponding objects will be added to the "3D History".

### Properties

The following object "**NcDbSection**" properties are available in the properties panel:

- **Is Live** - controls the display of a section on a three-dimensional model. Parts, through which the cutting plane passes, will receive an incision.

**Note:** The cut on the 3D model is for viewing only. On such planes it is impossible to build sketches and the rest of the geometry.

<b>No</b>	<b>Yes</b>
-----------	------------

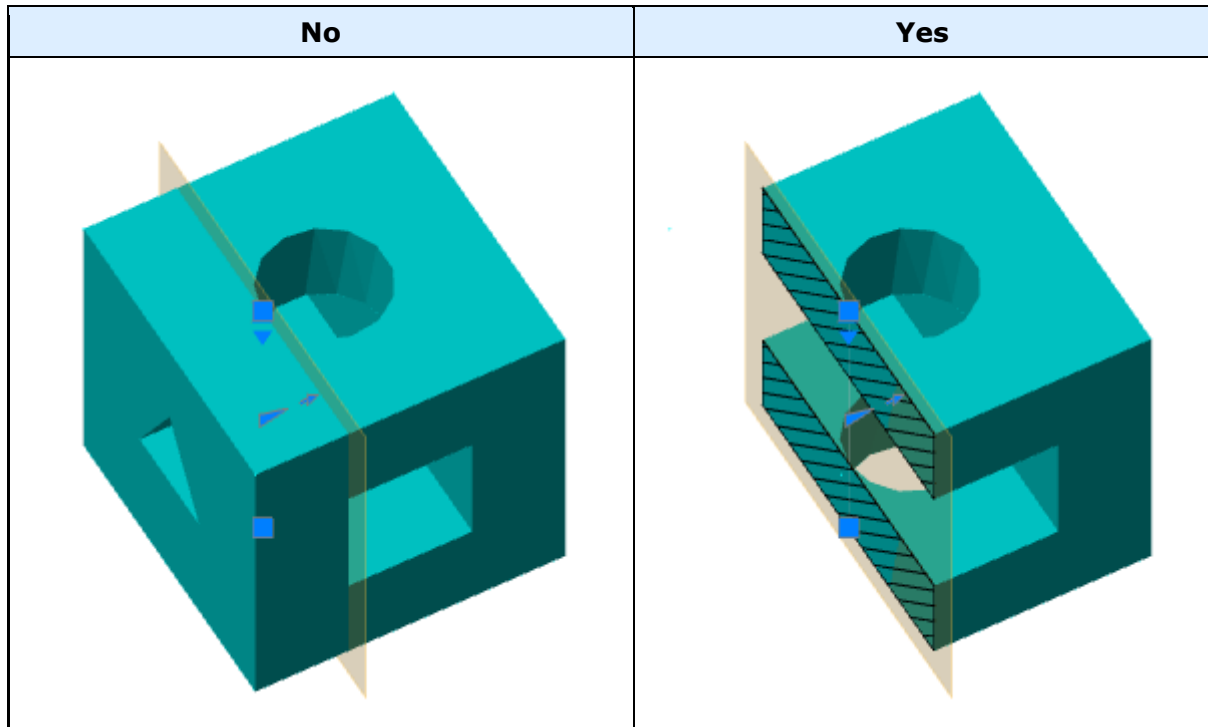

- **Name** - Name section. It is recommended to change the name in ["3D History"](#).
- **Type** - type section:

Plane - section on 1 plane

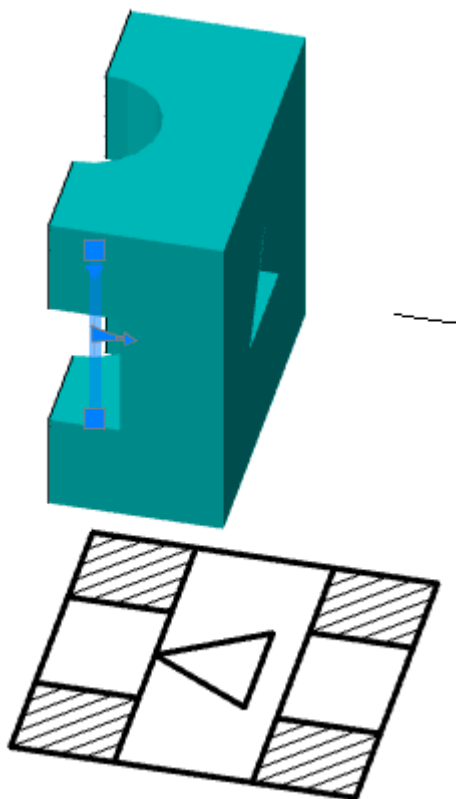

Boundary - section along 4 planes

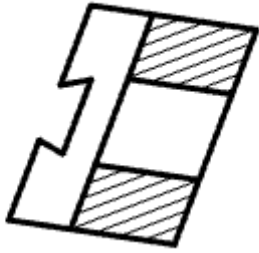
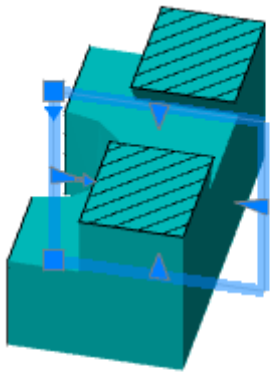

Volume - section along 6 planes

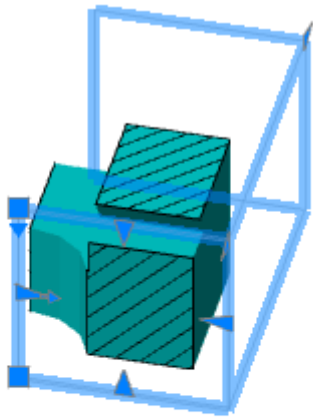

## Grips

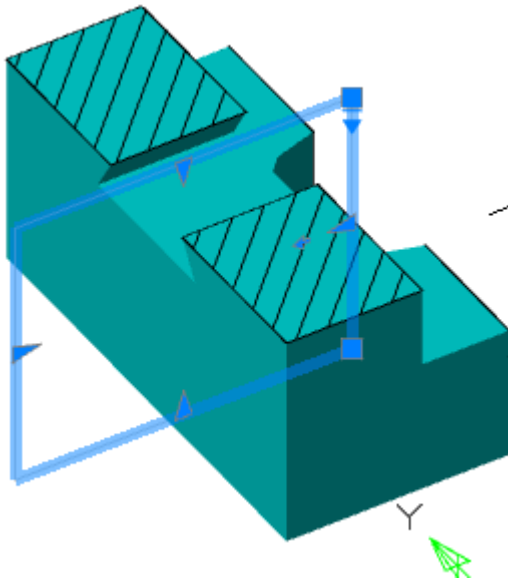

■ - grips change the position of the section in space. The upper grip is responsible for the movement, the lower grip is for the slope;

▲ - grips changes the position of the cutting plane (grip allows you to change the position of the plane only in one axis), the number of grips corresponds to the number of secant planes;

⬆ - grip shear direction changes;

▼ - grip change of secant plane properties: Section Plane, Section Boundary, Section Volume.

## 3D History

📁 Section. In "[3D History](#)" section is located in the root folder 📁 "**Sections**" and has child objects 📁 "[View](#)".

The following shortcut menu commands are available:

- **Rename (F2)** - rename a section.
- **Delete (Del)** - deletes the section and child objects from the model tree and model space.
- **Hide** - hides the section and child objects from the model space. Section icon becomes inactive.
- **Show** - shows the section and child objects in the model space. Section icon becomes active.
- **ShowInDocument** - focuses and highlights the section at the center of the model space.
- **Rebuild** - rebuilds an object in model space.

## 2D View

👤 Main menu: **3D - 2D Views** - 📄 **Projected view**.

👤 Ribbon: **3D Tools - Section** - 📄 **2D View**.

👤 Toolbar: **2D Views** - 📄 **Projected view**.

👤 Command line: **DRAWINGVIEW**.

The command allows you to create two-dimensional views from the three-dimensional part.

### *Procedure*

1. Call command  **"2D View"**.
2. Select the parts you want to create from. To complete the selection, press the **"Enter"** key.

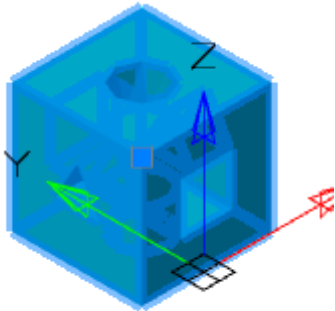

3. Specify the sheet where the view will be located. The command will offer a choice of all the sheets and model space that are in the document.
4. Position the main view on the plane. The view on the sheet is scaled so that it enters the sheet space and still has room for auxiliary projections.

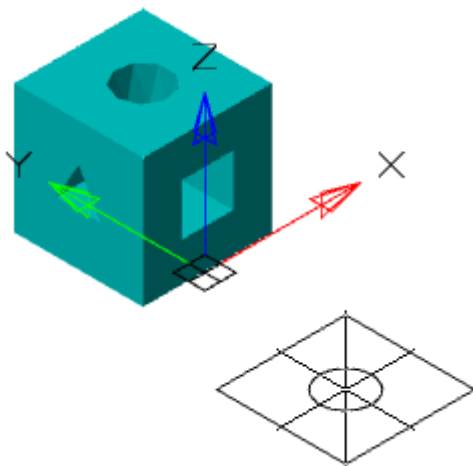

5. Position the necessary auxiliary projection views: flat and isometric. To finish inserting views, press the **"Enter"** key. Auxiliary projections are inserted on the same sheet where the main view is inserted.

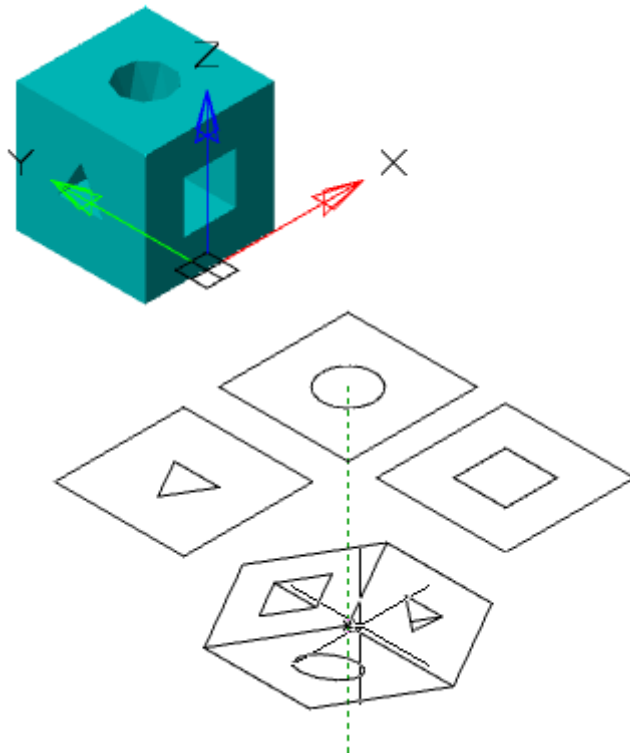

6. Will be created "**Projected Views**" and added to ["3D History"](#).

### **Edit**

The 2D View is called for editing: by the "**Edit**" command of the context menu on the view, by the "**Edit**" command from the history of 3D constructions, by double-clicking the LMB.

Editing is allowed if the view does not depend on the section object.

If the view is in paper space, it switches to model space.

In edit mode, all currently projected objects are selected, you can add objects by selecting a new object, or remove them by deselecting an object.

To complete editing, you must press the "**Enter**" key, all related views will be rebuilt according to a new set of objects.

### **Properties**

The following object properties are available in the properties panel:

**Name** - Name of the view. The name of the view is recommended to be changed in the ["3D History"](#).

**Fill Angle** - Angle of rotation.

**Enable Update** - The parameter controls the automatic view update when the part geometry is changed.

**Alignment** - The parameter controls alignment by coordinates with the set step when moving the view.

**Show Hidden Lines** - The parameter controls the display of hidden lines.

**Show hatch** - The parameter controls the display of hatching.

## Grips

■ **Moving grip** - serves to move the view in model space.

## 3D History

 View. In the "[3D History](#)" View belongs to part or section.

The following shortcut menu commands are available:

- **Rename (F2)** - allows you to rename a view.
- **Delete (Del)** - removes the view from the tree and model space.
- **Hide** - hides the view from the model space. View icon becomes inactive.
- **Show** - shows the view in the model space. View icon becomes active.
- **Show hidden lines** - shows hidden lines.
- **Hide hidden lines** - hide hidden lines.
- **ShowInDocument** - focuses and highlights the view in the center of the model space.
- **Rebuild** - rebuilds an object in model space.

## 2D Projection



Main menu: **3D - 2D Views -  2D Projected View.**



Ribbon: **3D Tools - Section -  2D Projection.**



Toolbar: **2D Views -  2D Projected View.**



Command line: **PROJECTIONVIEW.**

The command creates a projection for the created views.

## Procedure

1. Call command  "2D Projection".
2. Select the previously created view.

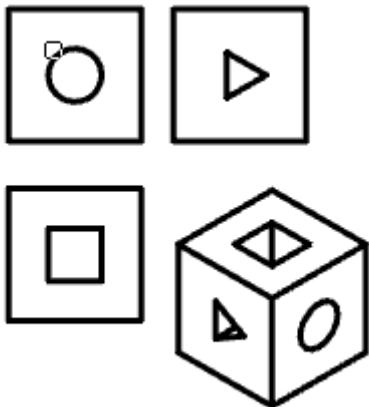

3. Position the projections on the plane. To complete the insertion, press the "**Enter**" key. Projection views vary depending on the location relative to the selected species.



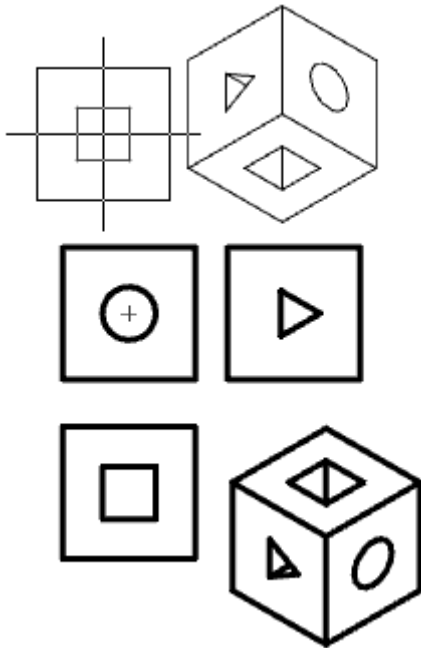

4. Will be created new objects **Projected View** and added to **3D History**.

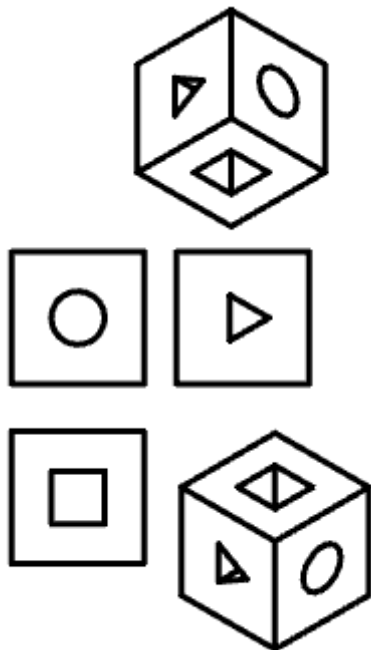

## **2D Section**

 Main menu: **3D - 2D Views - 2D Section View**.

 Ribbon: **3D Tools - Section - 2D Section**.

 Toolbar: **2D Views - 2D Section View**.

 Command line: **SECTIONVIEW**.

The command creates a 2D section view of the created projected views.

### Procedure

1. Select Projected View. The command will draw sections in the same place as the main view. The scale is taken from the main view.

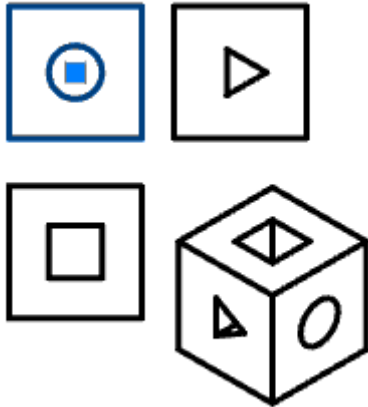

2. Call command  **"2D Section"**.

3. Specify the first and second cut points.

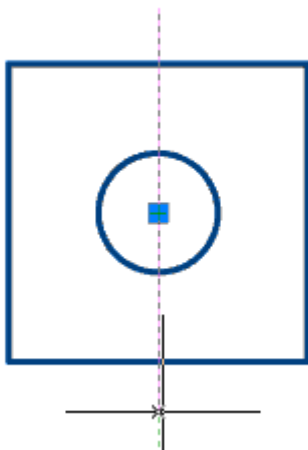

4. Place the view on the plane. Depending on the location (left or right of the line), the direction of the view will change.

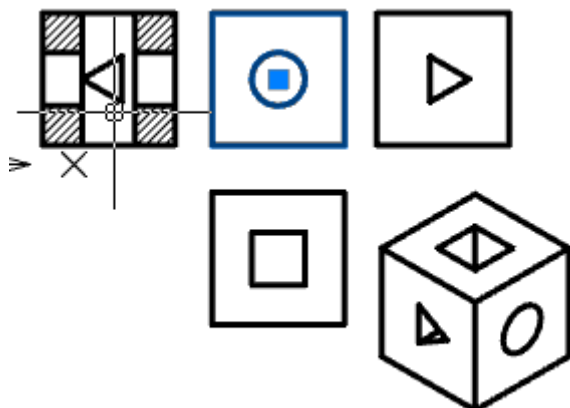

5. Will be created new object **"Projected View"** and added to **"3D History"**.

## Hatching Sections

 Main menu: **3D - 2D Views -  Hatching Sections.**

 Ribbon: **3D Tools - 2D Views -  Hatching Sections.**

 Toolbar: **2D Views -  Hatching Sections.**

 Command line: **DRAWINGVIEWAUTOHATCH.**

The command analyzes all cuts in the drawing and corrects them so that each of the parts in all cuts has the same pitch and angle of dashed lines, which is different from other parts.

### Procedure

1. Previously, a section with a 2D view must be created, containing several parts.

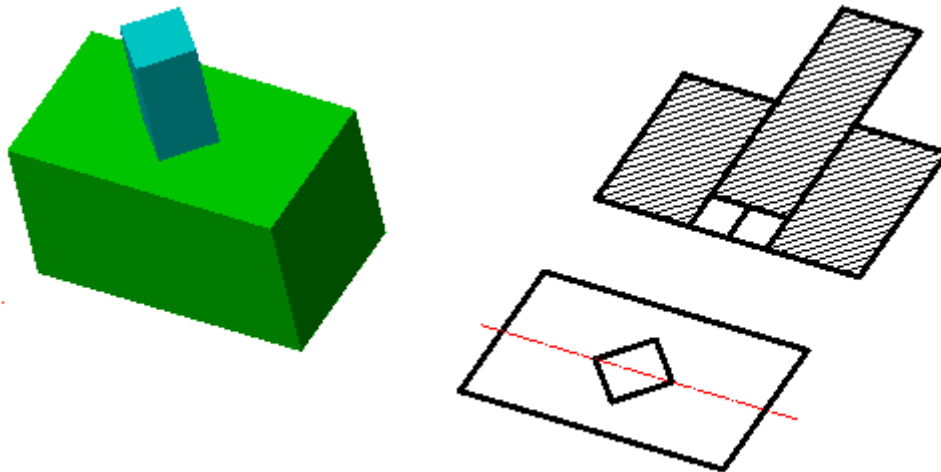

2. Call command  **"Hatching Sections"**. The team will analyze and correct the hatches. After the adjustment, the command will automatically end.

**Before**

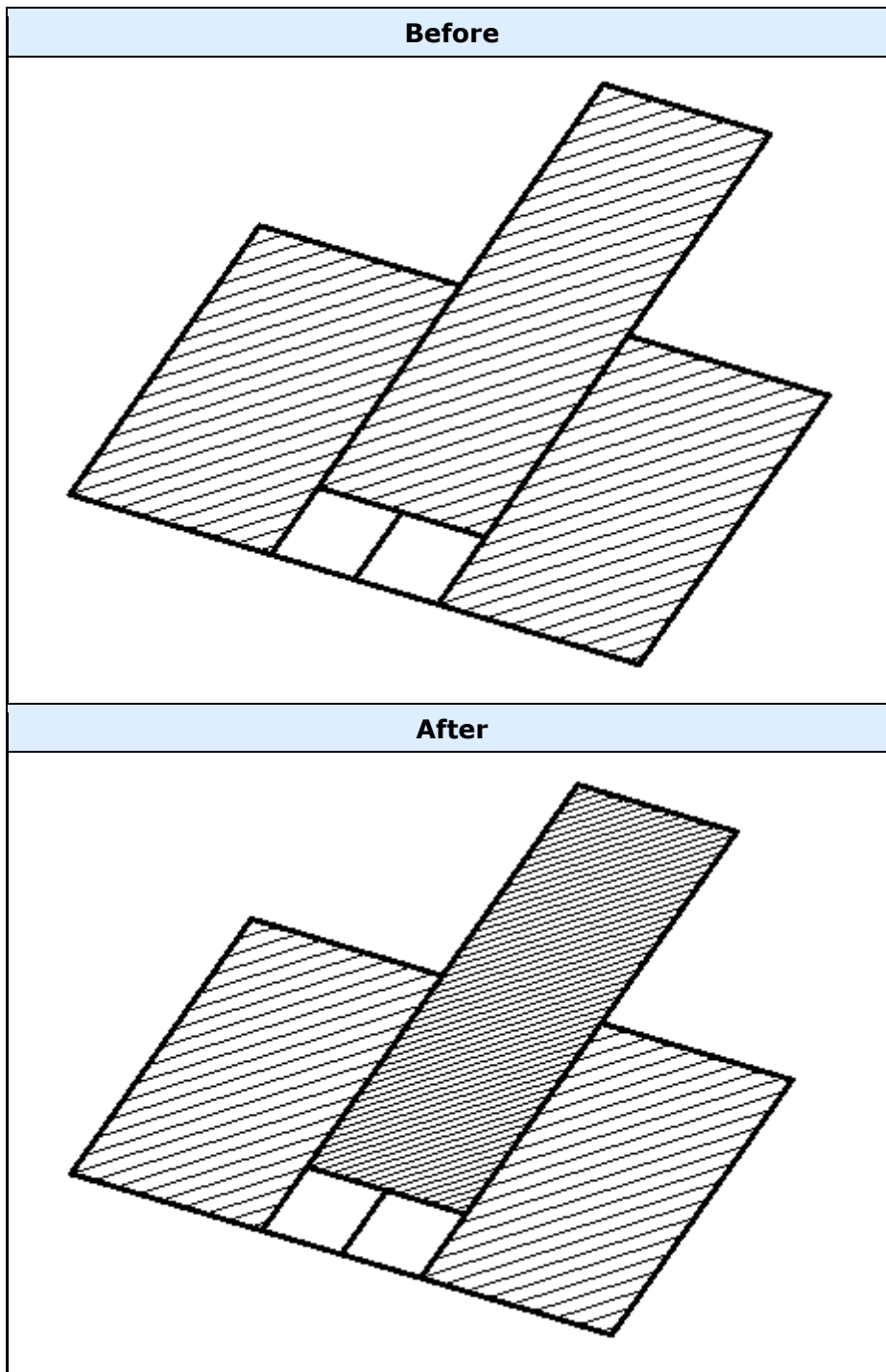

## ***2D Constraints***

## ***2D Constraints***

### ***Geometric constraints***



Command line: **GEOMCONSTRAINT.**

Geometric constraints allow you to create dependent geometry.

## Procedure

1. Call command  **"Geometric constraints"**.

**Note:** Also, each dependency has its own call command.

2. Select the required geometric dependence from the context menu or from the command line:

- [Coincident](#)
- [Collinear](#)
- [Vertical](#)
- [Horizontal](#)
- [Perpendicular](#)
- [Parallel](#)
- [Tangent](#)
- [Smooth](#)
- [Concentric](#)
- [Equal](#)
- [Symmetric](#)
- [Fix](#)

3. Take the necessary action.
4. Constraint will be installed.

## Coincident



Main menu: **Constraints - Geometric -  Coincident.**



Ribbon: **Constraints - Geometric -  Coincident.**



Toolbar: **Constraints -  Coincident .**



Command line: **GCCOINCIDENT.**

The command imposes a dependency overlap.

## Procedure

1. Call command  **"Coincident"**.

**Note:**

After the command is called, other dependency commands will be available in the context menu, which you can switch to if necessary. The list of dependencies is controlled by the switch "[Continuous add of constraints in manual mode \(autoadd until interrupted\)](#)".

2. Specify the first base point of the object or select the object.

To select a point, you must hover over the object. The selected point will be shown in orange. To select the desired point, you must hover over the object from the desired side. To select a point, press LMB. The selected point turns green.

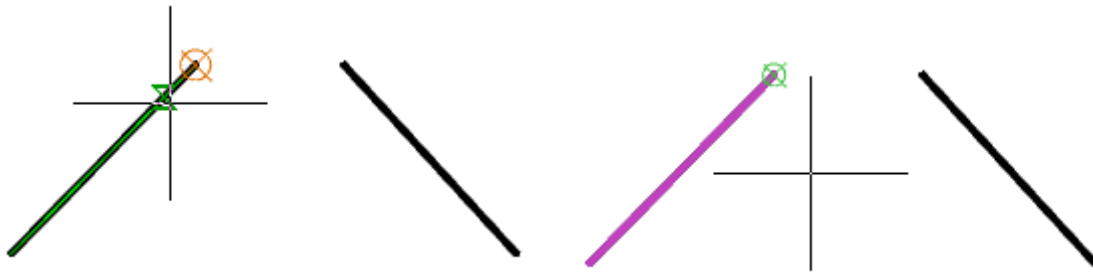

To select an object, select the **"O-object"** command in the context menu and select the required object. The subsequent selected point will be related to it collinearly.

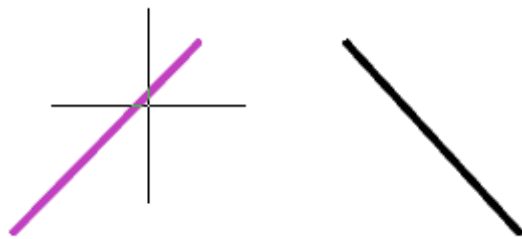

3. Select the point of the second object in the same way as the first. There will be a combination. The alignment point will be displayed in a yellow square.

If two points were chosen, then they will be combined. The second point moves to the point selected first.

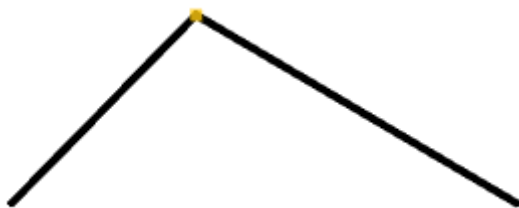

If an object and a point were selected, the second object will be placed in such a way that the point is collinear to the first object.

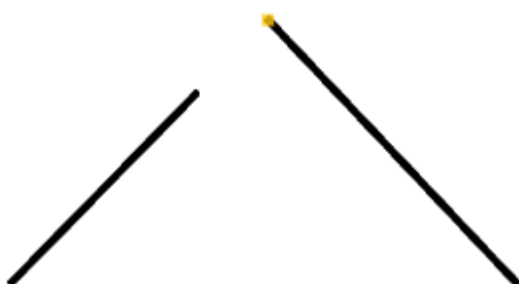

**Note:**

If the switch is on ["Continuous add of constraints in manual mode \(autoadd until interrupted\)"](#), after applying the dependency, the system will automatically switch to the insertion of the following dependency. To exit the loop, press **"Esc"**.

**Allowable objects and dependency points**

- control points of objects;
- line segment;

- circle;
- arc;
- segment of a polyline (rectilinear or arc);
- ellipse.

## Collinear

 Main menu: **Constraints - Geometric -  Collinear**.

 Ribbon: **Constraints - Geometric -  Collinear**.

 Toolbar: **Constraints -  Collinear**.

 Command line: **GCCOLLINEAR**.

The command imparts collinearity to objects.

### Procedure

1. Call command  "Collinear".

#### Note:

After the command is called, other dependency commands will be available in the context menu, which you can switch to if necessary. The list of dependencies is controlled by the switch "[Continuous add of constraints in manual mode \(autoadd until interrupted\)](#)".

2. Specify the first object, or select the command "M-multiple" from the context menu, which allows you to assign a dependency to several objects at once.

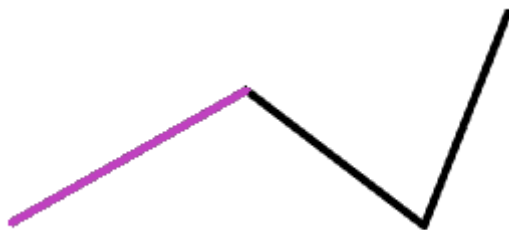

3. Specify the second object and subsequent objects (if the "M-multiple" command was selected).

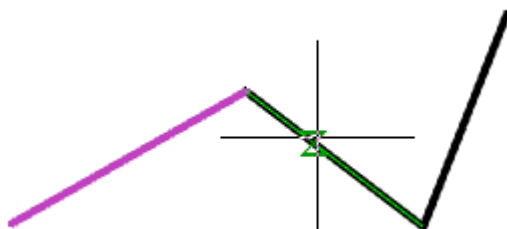

4. Objects will be collinear, that is, they will be located on the same line. Near the objects there will appear icons of superimposed dependencies.

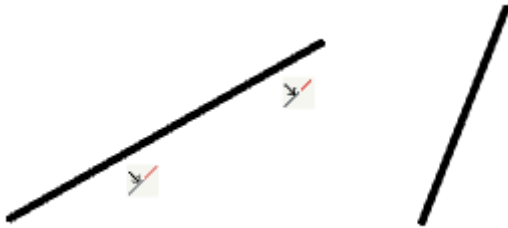

**Note:**

If the switch is on "[Continuous add of constraints in manual mode \(autoadd until interrupted\)](#)", after applying the dependency, the system will automatically switch to the insertion of the following dependency. To exit the loop, press "**Esc**".

**Allowable objects and dependency points**

- line segment;
- rectilinear segment of a polyline.

**Vertical**



Main menu: **Constraints - Geometric - Vertical**.



Ribbon: **Constraints - Geometric - Vertical**.



Toolbar: **Constraints - Vertical**.



Command line: **GCVERTICAL**.

The command superimposes verticality on objects.

**Procedure**

1. Call command **Vertical**.

**Note:**

After the command is called, other dependency commands will be available in the context menu, which you can switch to if necessary. The list of dependencies is controlled by the switch "[Continuous add of constraints in manual mode \(autoadd until interrupted\)](#)".

2. Determine how to apply the dependency: to an object or to a control point. In order to impose a dependency on the control point, call the context menu command **"2-2 points"**.
3. Select an object or points (depending on the selected method). Points can belong to different objects.

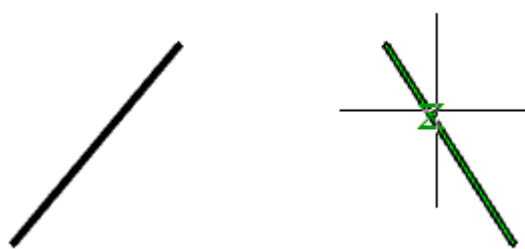
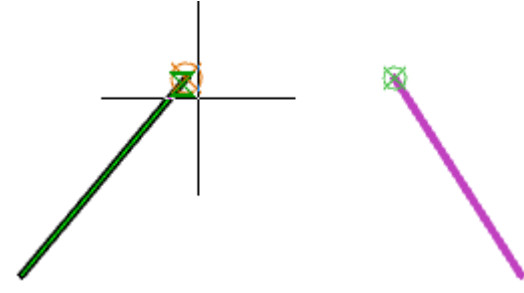
Object	2 points
	

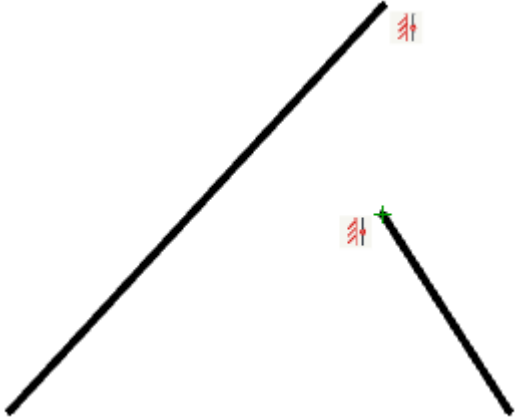

4. Dependence will be imposed. Near the objects there will appear icons of superimposed dependencies.

Object	2 points
	

**Note:**

If the switch is on ["Continuous add of constraints in manual mode \(autoadd until interrupted\)"](#), after applying the dependency, the system will automatically switch to the insertion of the following dependency. To exit the loop, press **"Esc"**.

**Allowable objects and dependency points**

- control points of objects;
- line segment;
- rectilinear segment of a polyline.

**Horizontal**



Main menu: **Constraints - Geometric -  Horizontal.**



Ribbon: **Constraints - Geometric -  Horizontal.**



Toolbar: **Constraints -  Horizontal.**



Command line: **GCHORIZONTAL.**

The command superimposes horizontality on objects.

**Procedure**

1. Call command  **"Horizontal"**.

**Note:**

After the command is called, other dependency commands will be available in the context menu, which you can switch to if necessary. The list of dependencies is controlled by the switch ["Continuous add of constraints in manual mode \(autoadd until interrupted\)"](#).

2. Determine how to apply the dependency: to an object or to a control point. In order to impose a dependency on the control point, call the context menu command **"2-2 points"**.

3. Select an object or points (depending on the selected method). Points can belong to different objects.

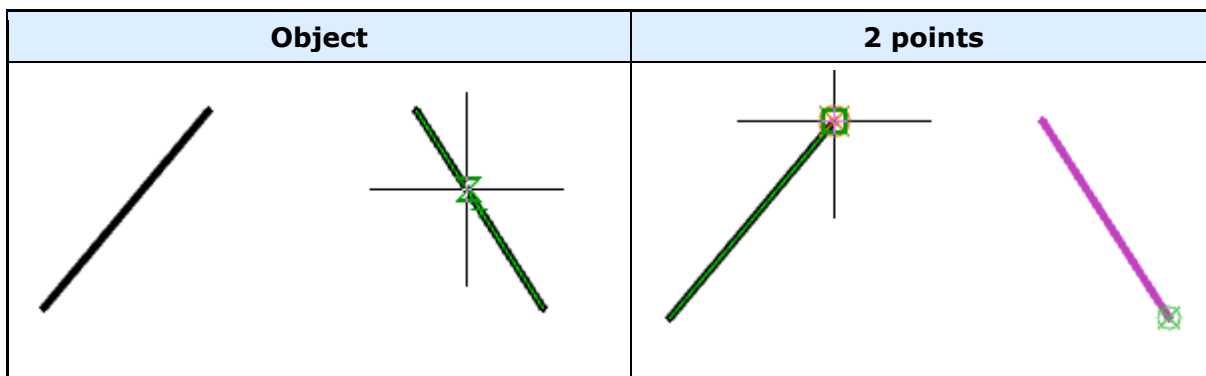

4. Dependence will be imposed. Near the objects there will appear icons of superimposed dependencies.

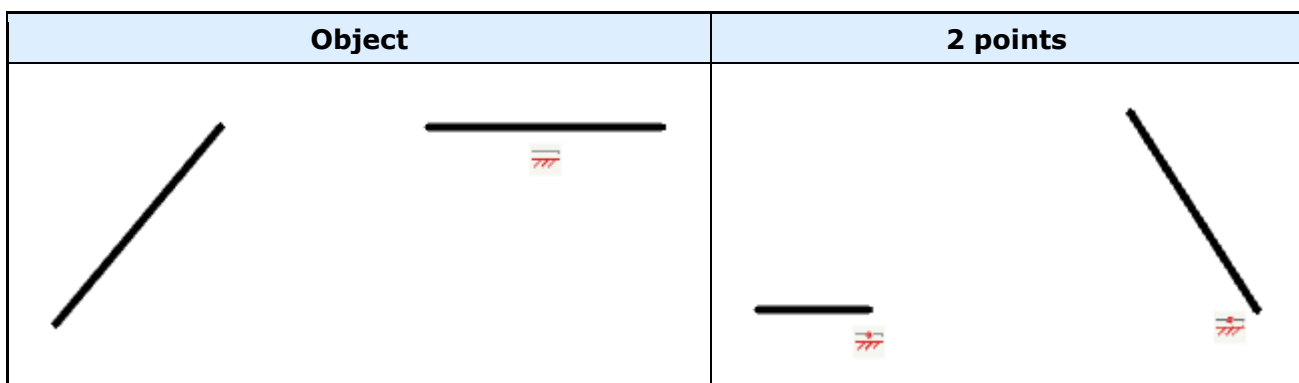

**Note:**

If the switch is on "[Continuous add of constraints in manual mode \(autoadd until interrupted\)](#)", after applying the dependency, the system will automatically switch to the insertion of the following dependency. To exit the loop, press "**Esc**".

### Allowable objects and dependency points

- control points of objects;
- line segment;
- rectilinear segment of a polyline.

## Perpendicular



Main menu: **Constraints - Geometric -  Perpendicular.**



Ribbon: **Constraints - Geometric -  Perpendicular.**



Toolbar: **Constraints -  Perpendicular.**



Command line: **GCPERPENDICULAR.**

The command imposes a perpendicularity on the objects.

### Procedure

1. Call command  "**Perpendicular**".

**Note:**

After the command is called, other dependency commands will be available in the context menu, which you can switch to if necessary. The list of dependencies is controlled by the switch "[Continuous add of constraints in manual mode \(autoadd until interrupted\)](#)".

2. Select the first object.

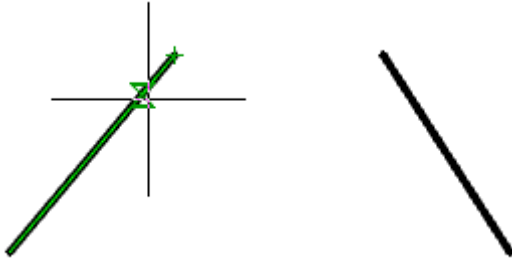

3. Select the second object.

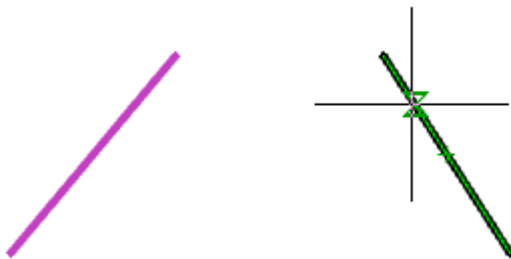

4. Constraint will be imposed. Objects will become perpendicular to each other. Near the objects there will appear icons of superimposed dependencies.



**Note:**

If the switch is on "[Continuous add of constraints in manual mode \(autoadd until interrupted\)](#)", after applying the dependency, the system will automatically switch to the insertion of the following dependency. To exit the loop, press "**Esc**".

**Allowable objects and dependency points**

- line segment;
- rectilinear segment of a polyline.

**Parallel**



Main menu: **Constraints - Geometric - // Parallel.**



Ribbon: **Constraints - Geometric - // Parallel.**

 Toolbar: **Constraints - // Parallel**.

 Command line: **GCPARALLEL**.

The command imposes a parallel dependency on objects.

### Procedure

1. Call command **// "Parallel"**.

#### Note:

After the command is called, other dependency commands will be available in the context menu, which you can switch to if necessary. The list of dependencies is controlled by the switch ["Continuous add of constraints in manual mode \(autoadd until interrupted\)"](#).

2. Select the first object.

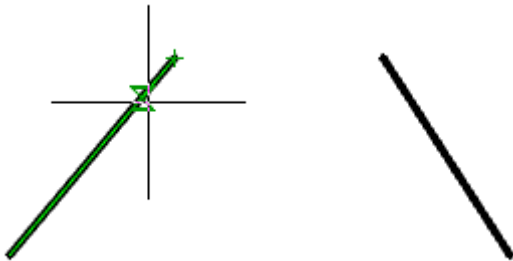

3. Select the second object.

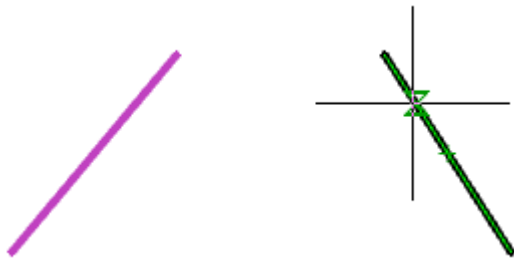

4. Dependence will be imposed. Objects will become parallel to each other. Near the objects there will appear icons of superimposed dependencies.

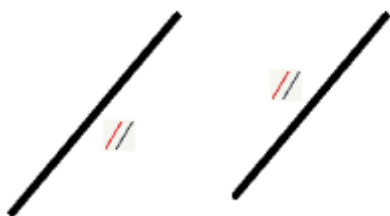

#### Note:

If the switch is on ["Continuous add of constraints in manual mode"](#), after applying the dependency, the system will automatically switch to the insertion of the following dependency. To exit the loop, press **"Esc"**.

### Allowable objects and dependency points

- line segment;
- rectilinear segment of a polyline.

## Tangent

 Main menu: **Constraints - Geometric -  Tangent.**

 Ribbon: **Constraints - Geometric -  Tangent.**

 Toolbar: **Constraints -  Tangent.**

 Command line: **GCTANGENT.**

The command superimposes the touch dependence on objects.

### Procedure

1. Call command  "Tangent".

#### Note:

After the command is called, other dependency commands will be available in the context menu, which you can switch to if necessary. The list of dependencies is controlled by the switch "[Continuous add of constraints in manual mode](#)".

2. Select the first object. One of the selectable objects should be: a circle, an arc, an arc segment of a polyline, an ellipse.

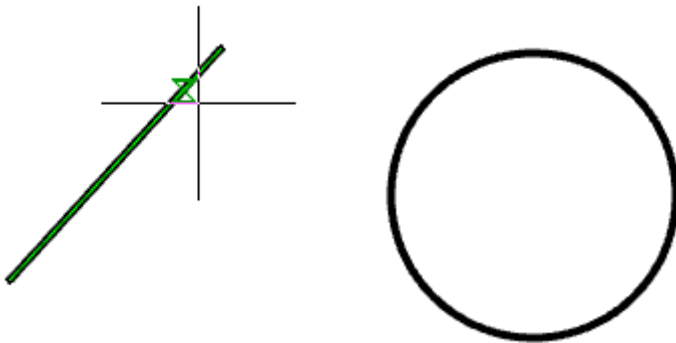

3. Select the second object. One of the selectable objects should be: a circle, an arc, an arc segment of a polyline, an ellipse.

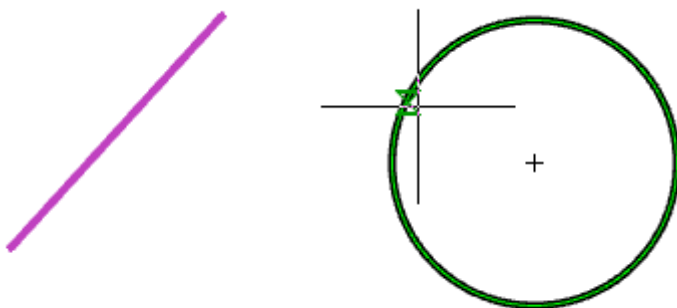

4. Dependence will be imposed. Objects will touch each other. Near the objects there will appear icons of superimposed dependencies.

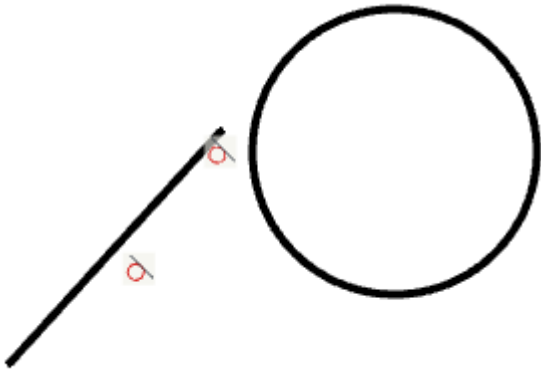

**Note:** If the switch is on "[Continuous add of constraints in manual mode](#)", after applying the dependency, the system will automatically switch to the insertion of the following dependency. To exit the loop, press "**Esc**".

### **Allowable objects and dependency points**

- line segment;
- rectilinear segment of a polyline;
- circle, arc, arc segment of a polyline, ellipse;
- combinations of circles, arcs, arc segments of polylines, ellipses.

### **Smooth**



Main menu: **Constraints - Geometric -  Smooth.**



Ribbon: **Constraints - Geometric -  Smooth.**



Toolbar: **Constraints -  Smooth.**



Command line: **GCSMOOTH.**

The command imposes the smooth constraint on a spline and object.

### **Procedure**

1. Call command  "**Smooth**".

**Note:**

After the command is called, other dependency commands will be available in the context menu, which you can switch to if necessary. The list of dependencies is controlled by the switch "[Continuous add of constraints in manual mode](#)".

2. Select a point on the first curve.

**Important!**

The first curve should always be a spline!

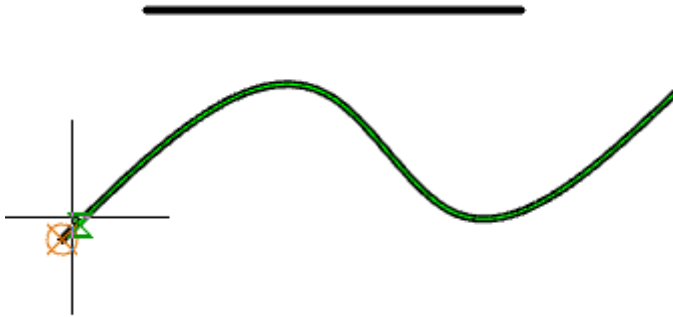

3. Select a point on the second curve.

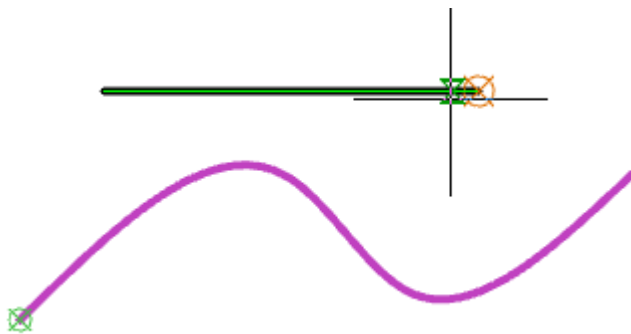

4. Dependence will be imposed. Near the objects there will appear icons of superimposed dependencies.



**Note:**

If the switch is on ["Continuous add of constraints in manual mode"](#), after applying the dependency, the system will automatically switch to the insertion of the following dependency. To exit the loop, press **"Esc"**.

**Allowable objects and dependency points**

- spline;
- line segment;
- rectilinear and arc segment of the polyline;
- arc.

**Concentric**



Main menu: **Constraints - Geometric - Concentric.**



Ribbon: **Constraints - Geometric - Concentric.**



Toolbar: **Constraints - Concentric.**



Command line: **GCCONCENTRIC.**

Command constraint on the alignment of circles, arcs and other objects.

### Procedure

1. Call command  "Concentric".

**Note:**

After the command is called, other dependency commands will be available in the context menu, which you can switch to if necessary. The list of dependencies is controlled by the switch ["Continuous add of constraints in manual mode"](#).

2. Select the first object.

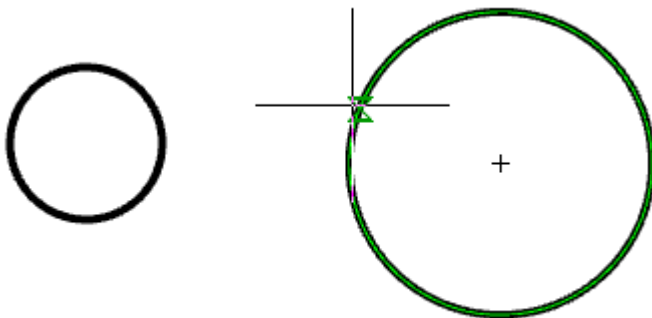

3. Select the second object.

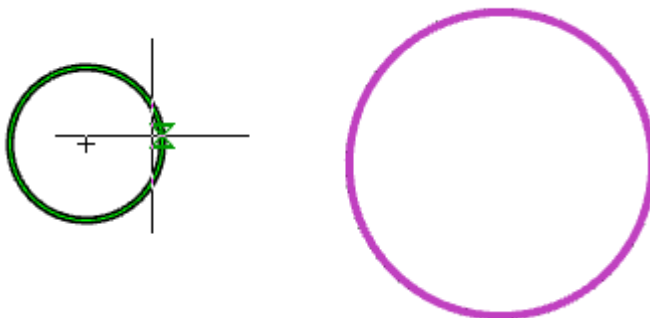

4. Dependence will be imposed. Near the objects there will appear icons of superimposed dependencies.

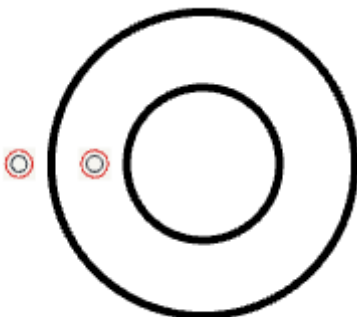

**Note:**

If the switch is on ["Continuous add of constraints in manual mode"](#), after applying the dependency, the system will automatically switch to the insertion of the following dependency. To exit the loop, press "Esc".



## Allowable objects and dependency points

- circle;
- arc;
- arc segment of a polyline;
- ellipse.

## Equal



Main menu: **Constraints - Geometric - = Equal**.



Ribbon: **Constraints - Geometric - = Equal**.



Toolbar: **Constraints - = Equal**.



Command line: **GCEQUAL**.

The command sets the relationship between the equality of dimensions (length, diameter, radius, etc.) of two or more objects.

## Procedure

1. Call command **= "Equal"**.

### Note:

After the command is called, other dependency commands will be available in the context menu, which you can switch to if necessary. The list of dependencies is controlled by the switch ["Continuous add of constraints in manual mode"](#).

2. Specify the first object, or select the command **"M-multiple"** from the context menu, which allows you to assign a dependency to several objects at once.

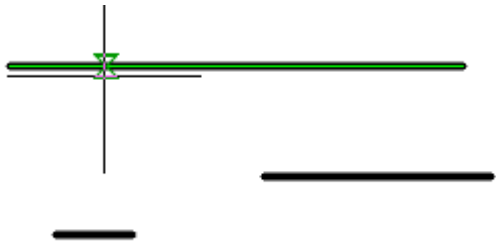

3. Specify the second object and subsequent objects (if the **"M-multiple"** command has been selected).



4. Dependence will be imposed. Near the objects there will appear icons of superimposed dependencies.

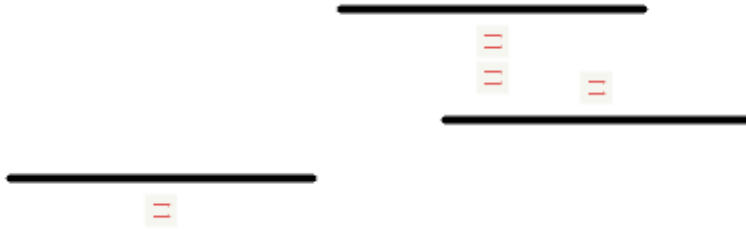

**Note:**

If the switch is on "[Continuous add of constraints in manual mode](#)", after applying the dependency, the system will automatically switch to the insertion of the following dependency. To exit the loop, press "**Esc**".

**Allowable objects and dependency points**

- line segment;
- rectilinear and arc segment of the polyline;
- circle;
- arc.

**Symmetric**



Main menu: **Constraints - Geometric -  Symmetric.**



Ribbon: **Constraints - Geometric -  Symmetric.**



Toolbar: **Constraints -  Symmetric.**



Command line: **GCSYMMETRIC.**

The command sets the symmetry of the two objects relative to the axis of symmetry (line).

**Procedure**

1. Call command  "**Symmetric**".

**Note:**

After the command is called, other dependency commands will be available in the context menu, which you can switch to if necessary. The list of dependencies is controlled by the switch "[Continuous add of constraints in manual mode](#)".

2. Determine how to apply the dependency: to an object or to a control point. In order to impose a dependency on the control point, call the context menu command "2-2 points".
3. Select the first object or point (depending on the selected method). Points can belong to different objects.

Object	2 points
--------	----------

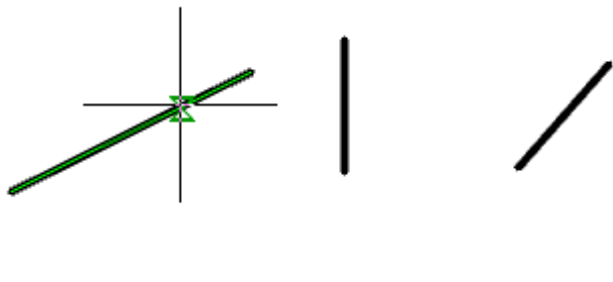
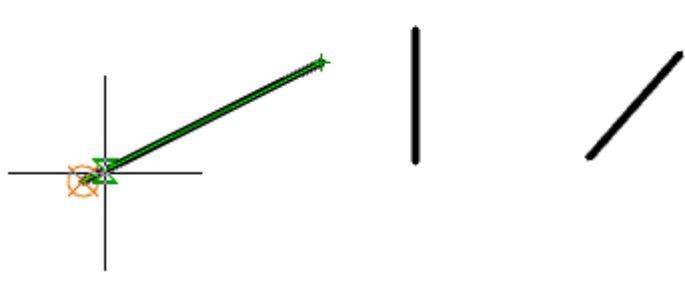
Object	2 points
	

4. Select the second object or point (depending on the selected method). Points can belong to different objects.

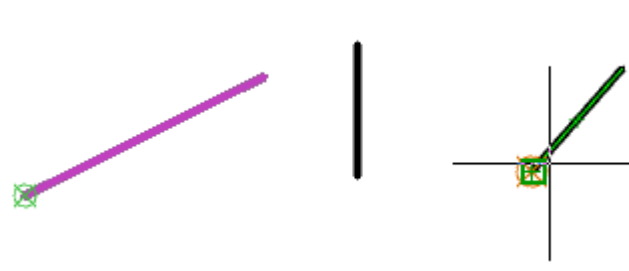
Object	2 points
	

5. Select the axis of symmetry.

**Important!** The axis of symmetry must be a line.

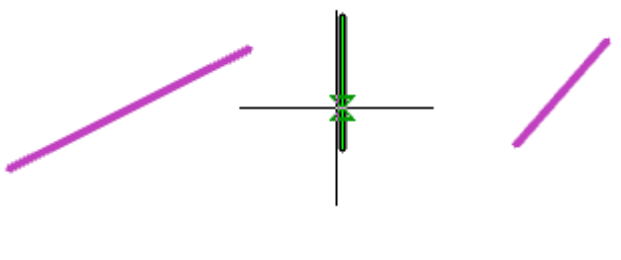
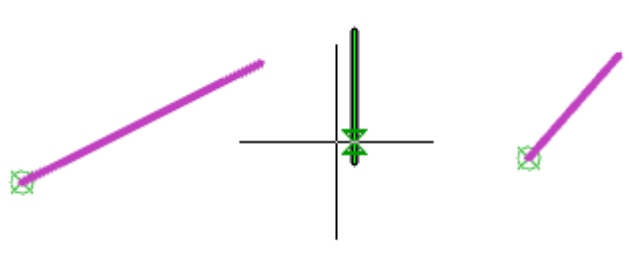
Object	2 points
	

6. Dependence will be imposed. Near the objects there will appear icons of superimposed dependencies.

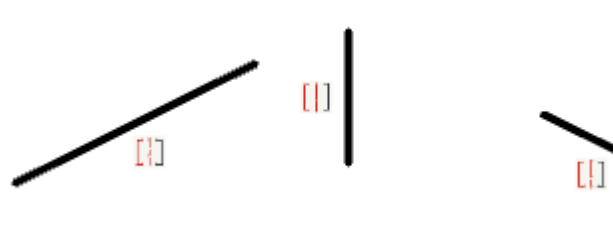
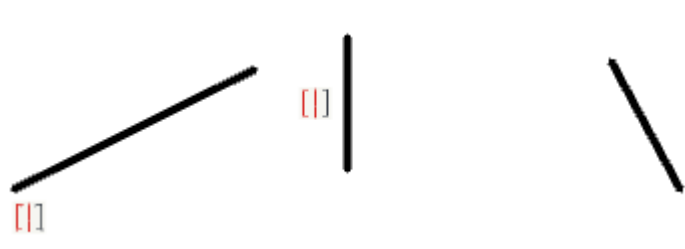
Object	2 points
	

**Note:** If the switch is on "[Continuous add of constraints in manual mode](#)", after

applying the dependency, the system will automatically switch to the insertion of the following dependency. To exit the loop, press **"Esc"**.

### *Allowable objects and dependency points*

- line segment;
- rectilinear and arc segment of the polyline;
- circle;
- arc;
- ellipse.

### *Fix*



Main menu: **Constraints - Geometric -  Fix.**



Ribbon: **Constraints - Geometric -  Fix.**



Toolbar: **Constraints -  Fix.**



Command line: **GCFIX.**

The command captures a point or object in current coordinates.

### *Procedure*

1. Call command  **"Fix"**.

#### **Note:**

After the command is called, other dependency commands will be available in the context menu, which you can switch to if necessary. The list of dependencies is controlled by the switch ["Continuous add of constraints in manual mode"](#).

2. Determine how to add a dependency: to a control point or to an object. To impose a dependency on an object, call the command of the context menu **"O-object"**.
3. Select an object or a point (depending on the selected method).



4. Dependence will be imposed. Near the objects there will appear icons of superimposed dependencies.



#### **Note:**

If the switch is on ["Continuous add of constraints in manual mode"](#), after applying the dependency, the system will automatically switch to the insertion of the following dependency. To exit the loop, press **"Esc"**.

## Allowable objects and dependency points

- line segment;
- rectilinear and arc segment of the polyline;
- arc;
- circle;
- ellipse;
- spline.

## Parametric dimensions

### Aligned



Main menu: **Constraints - Parametric dimensions -  Aligned.**



Ribbon: **Constraints - Parametric dimensions -  Aligned.**



Toolbar: **Constraints -  Aligned.**



Command line: **DCALIGNED.**

The command sets the dimensional constraint to apply parallel dimensions.

### Procedure

1. Call command  "**Aligned**".

#### Note:

After the command is called, other dependency commands will be available in the context menu, which you can switch to if necessary. The list of dependencies is controlled by the switch "[Continuous add of constraints in manual mode](#)".

2. Determine how to insert an equalized size: 2 points (by default when the command is called), O-object, P-point\_line, 2-2lines. The method of insertion is determined by selecting the appropriate command from the context menu.

- **2 points** - sets the parallel dimension to two points.

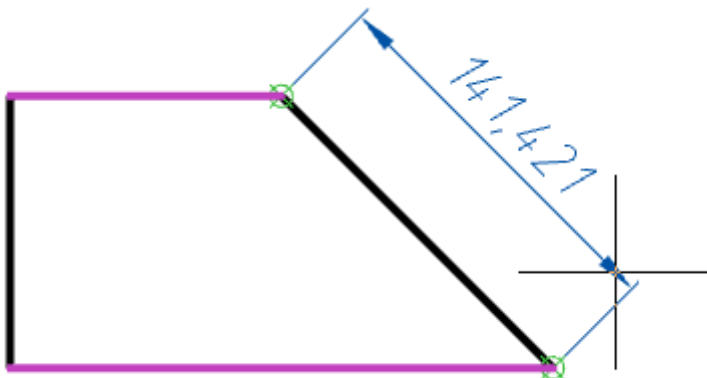

- **O-object** - sets the parallel size for the selected object.

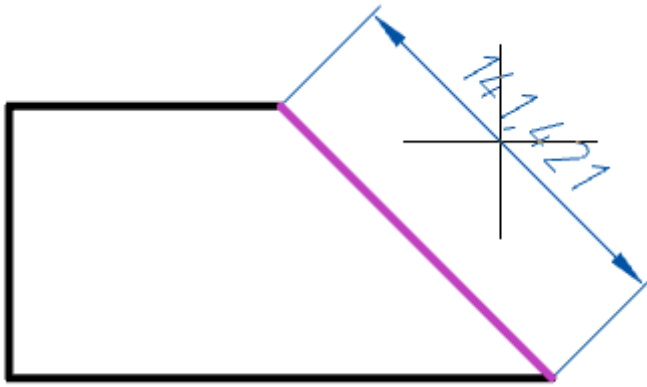

- **P-point\_line** - sets the size that is parallel to the normal from the selected point to the selected segment.

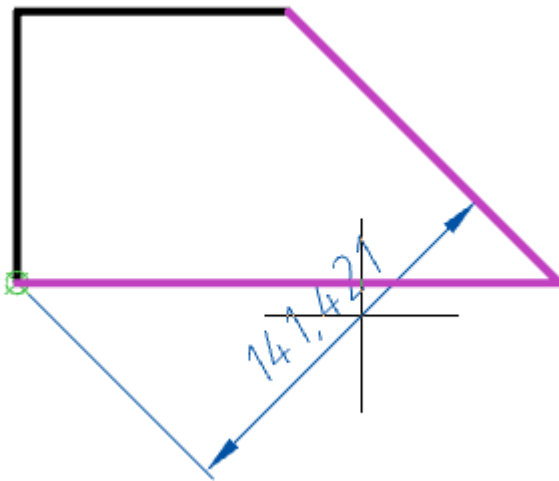

- **2-2lines** - sets the size parallel to the normal between two segments.

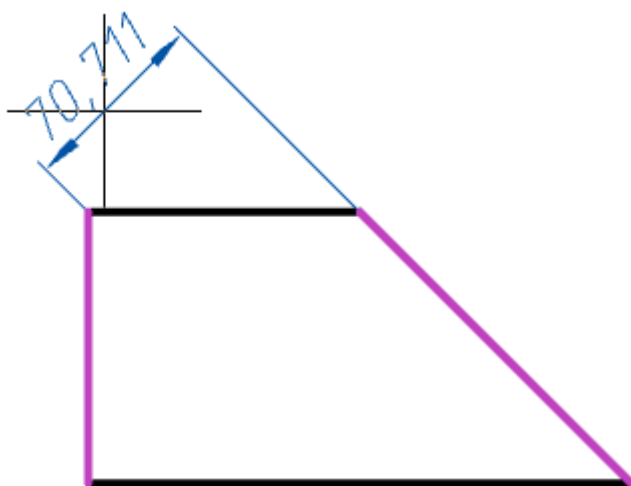

3. Specify the required objects, depending on the selected insertion method.
4. Place the parametric dimension on the drawing.
5. Parametric size will be built and added to the ["Parameters Manager"](#). A variable is assigned to the parameter dimension.

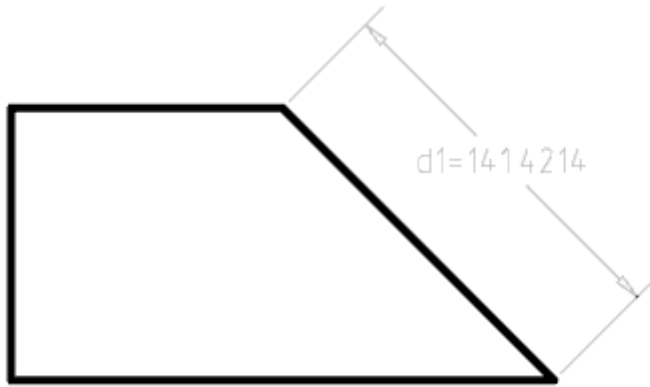

**Note:** If the switch is on "[Continuous add of constraints in manual mode](#)", after applying the dependency, the system will automatically switch to the insertion of the following dependency. To exit the loop, press "**Esc**".

### Edit

To edit the parametric size, double-click on the size. An editing dialog opens, where you can change the name of the variable and the value. The value can be a [formula](#).

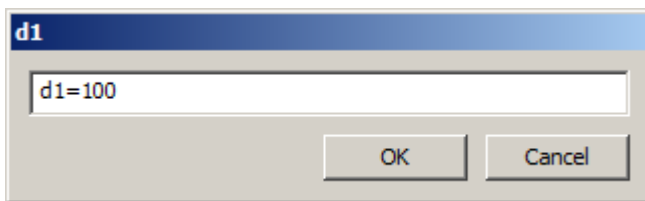

Also, the parametric size can be edited in "[Parameters Manager](#)".

### Allowable objects and dependency points

- control points of objects;
- line segment;
- arc;
- segment and control point;
- two segments;
- segment of a polyline (rectilinear or arc).

## Linear



Main menu: **Constraints - Parametric dimensions -  Linear.**



Ribbon: **Constraints - Parametric dimensions -  Linear.**



Toolbar: **Constraints -  Linear.**



Command line: **DCLINEAR.**

The command sets the linear dimension relationship. The linear dimension is constructed orthogonally to the coordinate system.

### Procedure

1. Call command  "**Linear**".

**Note:**

After the command is called, other dependency commands will be available in the context menu, which you can switch to if necessary. The list of dependencies is controlled by the switch "[Continuous add of constraints in manual mode](#)".

2. Determine how to insert an equalized size: 2 points (by default when the command is called) or O-object. The method of insertion is determined by selecting the appropriate command from the context menu.

- **2 points** - sets the orthogonal size by two points.

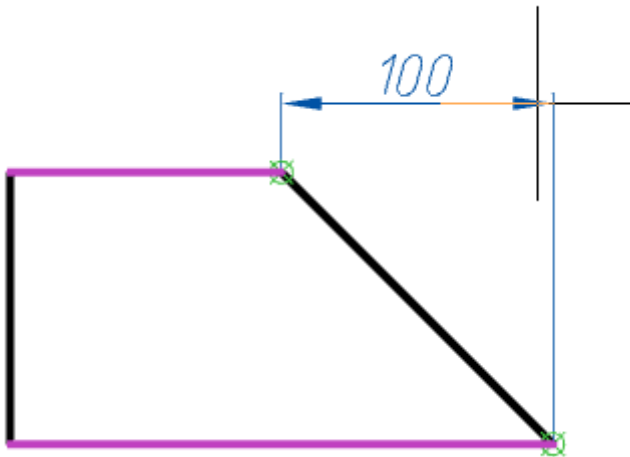

- **O-object** - sets the orthogonal size for the selected object.

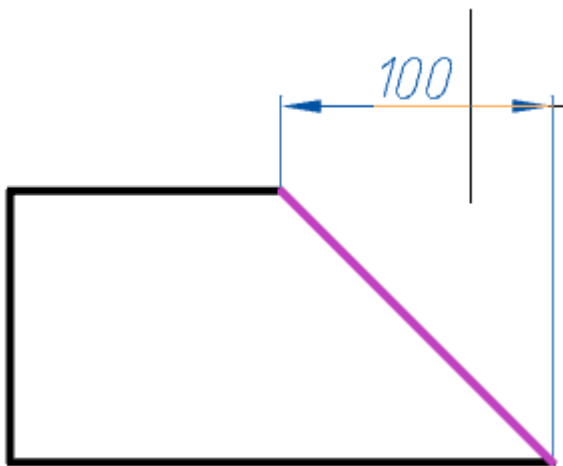

3. Specify the required objects, depending on the selected insertion method.
4. Place the parametric dimension on the drawing.
5. Parametric size will be built and added to the "[Parameters Manager](#)". A variable is assigned to the parameter dimension.



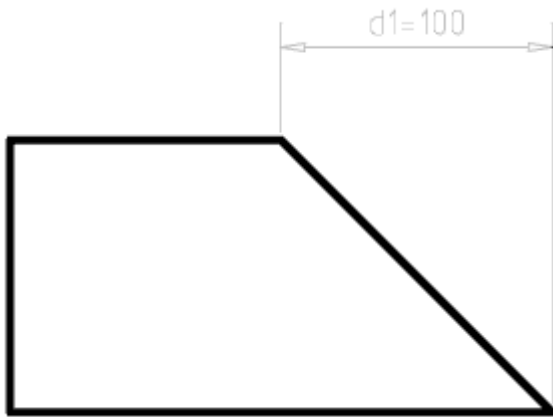

**Note:**

If the switch is on "[Continuous add of constraints in manual mode](#)", after applying the dependency, the system will automatically switch to the insertion of the following dependency. To exit the loop, press "**Esc**".

**Edit**

To edit the parametric size, double-click on the size. An editing dialog opens, where you can change the name of the variable and the value. The value can be a [formula](#).

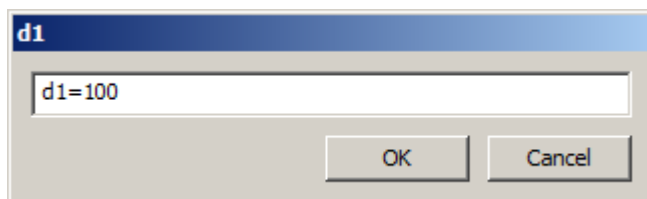

Also, the parametric size can be edited in "[Parameters Manager](#)".

**Allowable objects and dependency points**

- control points of objects;
- line segment;
- arc;
- segment of a polyline (rectilinear or arc).

**Horizontal**



Main menu: **Constraints - Parametric dimensions -  Horizontal.**



Ribbon: **Constraints - Parametric dimensions -  Horizontal.**



Toolbar: **Constraints -  Horizontal.**



Command line: **DCHORIZONTAL.**

The command sets a linear horizontal dimension relationship.

**Procedure**

1. Call command  "**Horizontal**".

**Note:**

After the command is called, other dependency commands will be available in the context menu, which you can switch to if necessary. The list of

dependencies is controlled by the switch "[Continuous add of constraints in manual mode](#)".

2. Determine how to insert an equalized size: 2 points (by default when the command is called) or O-object. The method of insertion is determined by selecting the appropriate command from the context menu.

- **2 points** - sets the horizontal size by two points.

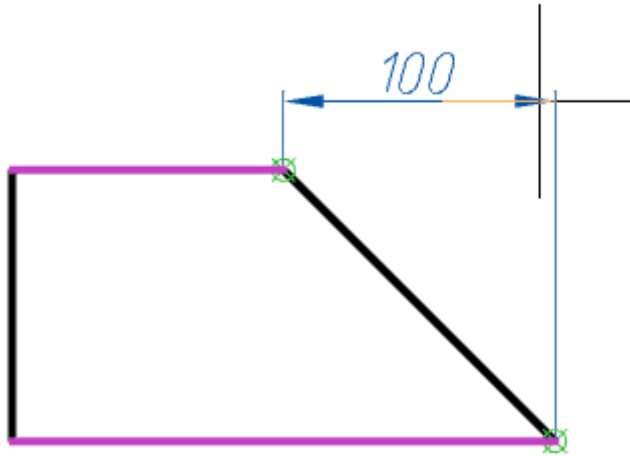

- **O-object** - sets the horizontal size for the selected object.

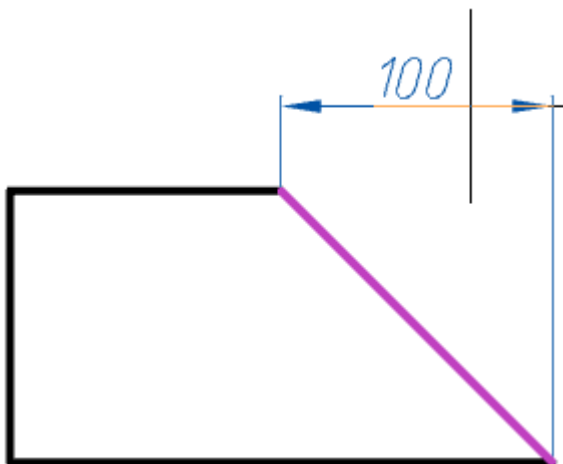

3. Specify the required objects, depending on the selected insertion method.

4. Place the parametric dimension on the drawing.

5. Parametric size will be built and added to the "[Parameters Manager](#)". A variable is assigned to the parameter dimension.

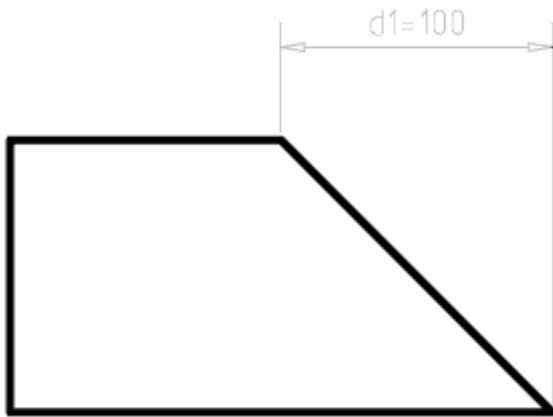

**Note:**

If the switch is on "[Continuous add of constraints in manual mode](#)", after applying the dependency, the system will automatically switch to the insertion of the following dependency. To exit the loop, press "**Esc**".

**Edit**

To edit the parametric size, double-click on the size. An editing dialog opens, where you can change the name of the variable and the value. The value can be a [formula](#).

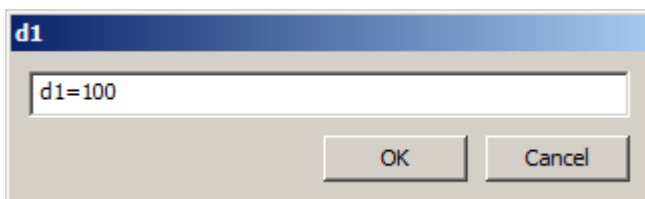

Also, the parametric size can be edited in "[Parameters Manager](#)".

**Allowable objects and dependency points**

- control points of objects;
- line segment;
- arc;
- segment of a polyline (rectilinear or arc).

**Vertical**



Main menu: **Constraints - Parametric dimensions - Vertical**.



Ribbon: **Constraints - Parametric dimensions - Vertical**.



Toolbar: **Constraints - Vertical**.



Command line: **DCVERTICAL**.

The command sets a linear vertical dimension relationship.

**Procedure**

1. Call command **Vertical**.

**Note:**

After the command is called, other dependency commands will be available in the context menu, which you can switch to if necessary. The list of

dependencies is controlled by the switch "[Continuous add of constraints in manual mode \(autoadd until interrupted\)](#)".

2. Determine how to insert an equalized size: 2 points (by default when the command is called) or O-object. The method of insertion is determined by selecting the appropriate command from the context menu.

- **2 points** - sets the vertical dimension to two points.

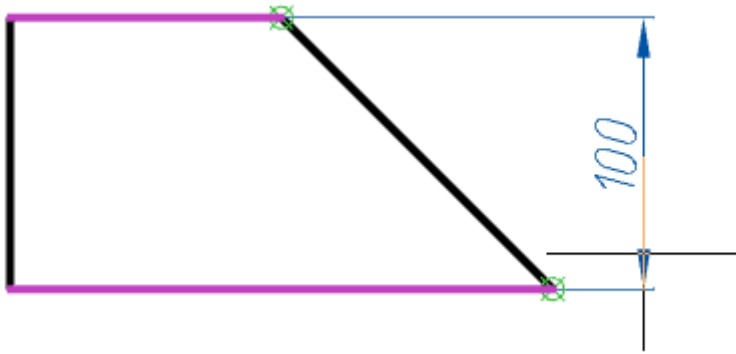

- **O-object** - sets the vertical size for the selected object.

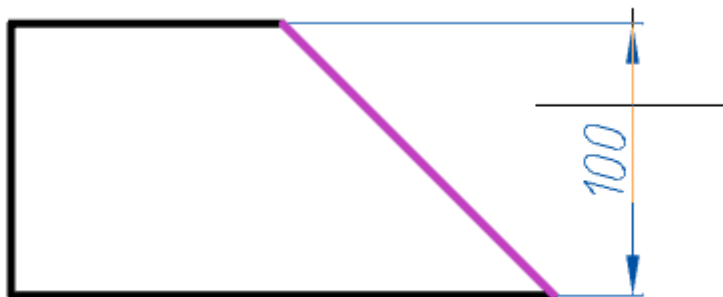

3. Specify the required objects, depending on the selected insertion method.

4. Place the parametric dimension on the drawing.

5. Parametric size will be built and added to the "[Parameters Manager](#)". A variable is assigned to the parameter dimension.

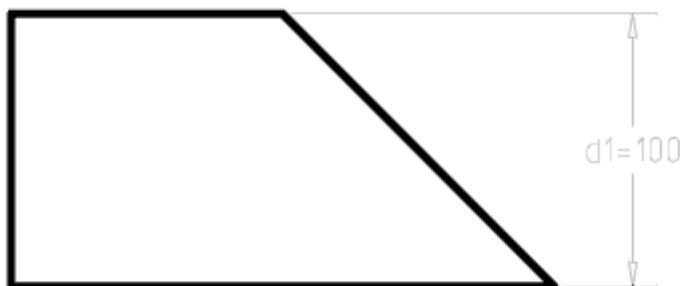

**Note:**

If the switch is on "[Continuous add of constraints in manual mode](#)", after applying the dependency, the system will automatically switch to the insertion of the following dependency. To exit the loop, press "**Esc**".

## Edit

To edit the parametric size, double-click on the size. An editing dialog opens, where you can change the name of the variable and the value. The value can be a [formula](#).

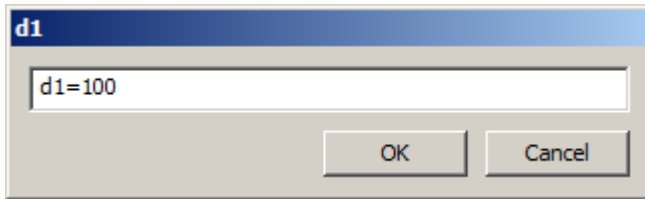

Also, the parametric size can be edited in "[Parameters Manager](#)".

## Allowable objects and dependency points

- control points of objects;
- line segment;
- arc;
- segment of a polyline (rectilinear or arc).

## Radial



Main menu: **Constraints - Parametric dimensions -  Radial.**



Ribbon: **Constraints - Parametric dimensions -  Radial.**



Toolbar: **Constraints -  Radial.**



Command line: **DCRADIAL.**

The command sets the radial dimensional dependence on an arc or circle.

## Procedure

1. Call command  "**Radial**".

### Note:

After the command is called, other dependency commands will be available in the context menu, which you can switch to if necessary. The list of dependencies is controlled by the switch "[Continuous add of constraints in manual mode](#)".

2. Specify an arc or circle.

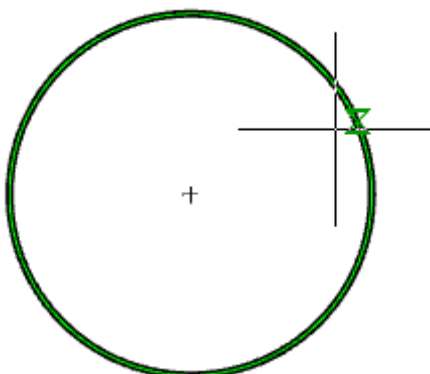

3. Arrange the parametric dimension on the drawing.

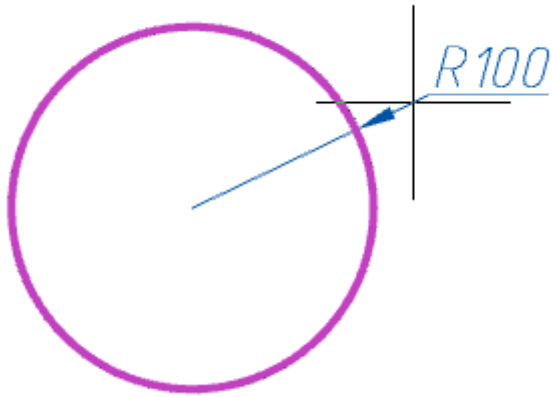

4. Parametric size will be built and added to the ["Parameters Manager"](#). A variable is assigned to the parameter dimension.

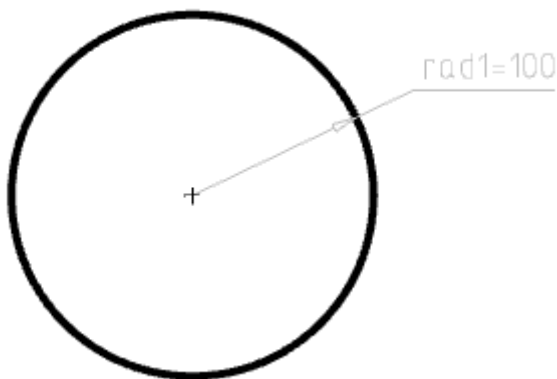

**Note:**

If the switch is on ["Continuous add of constraints in manual mode"](#), after applying the dependency, the system will automatically switch to the insertion of the following dependency. To exit the loop, press **"Esc"**.

**Edit**

To edit the parametric size, double-click on the size. An editing dialog opens, where you can change the name of the variable and the value. The value can be a [formula](#).

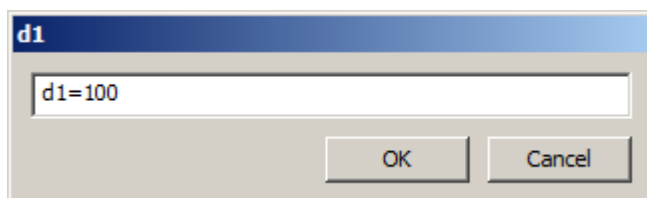

Also, the parametric size can be edited in ["Parameters Manager"](#).

**Allowable objects and dependency points**

- circle;
- arc;
- arc segment of a polyline.

**Diameter**



Main menu: **Constraints - Parametric dimensions -  Diameter.**

 Ribbon: **Constraints - Parametric dimensions - Diameter**.

 Toolbar: **Constraints - Diameter**.

 Command line: **DCDIAMETER**.

This command sets the diametrical size dependence on the arc or circle.

### Procedure

1. Call command  **"Diameter"**.

#### Note:

After the command is called, other dependency commands will be available in the context menu, which you can switch to if necessary. The list of dependencies is controlled by the switch "[Continuous add of constraints in manual mode](#)".

2. Specify an arc or circle.

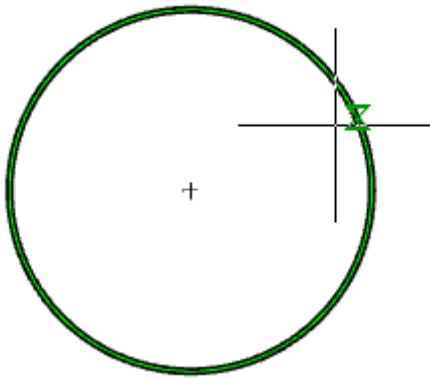

3. Arrange the parametric dimension on the drawing.

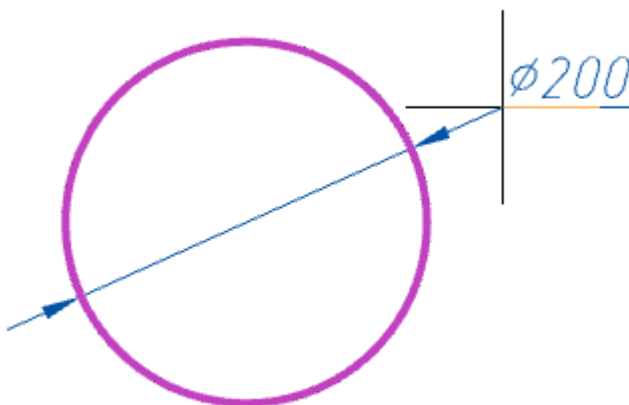

4. Parametric size will be built and added to the "[Parameters Manager](#)". A variable is assigned to the parameter dimension.

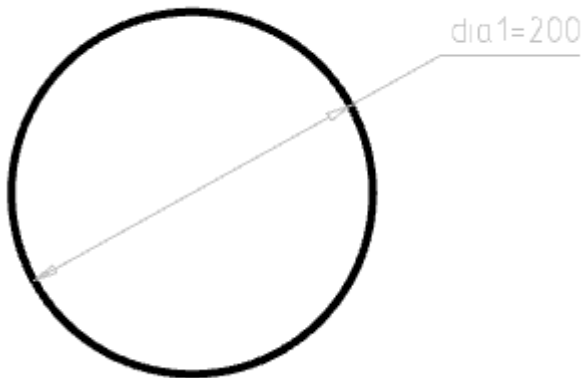

**Note:**

If the switch is on "[Continuous add of constraints in manual mode](#)", after applying the dependency, the system will automatically switch to the insertion of the following dependency. To exit the loop, press "**Esc**".

**Edit**

To edit the parametric size, double-click on the size. An editing dialog opens, where you can change the name of the variable and the value. The value can be a [formula](#).

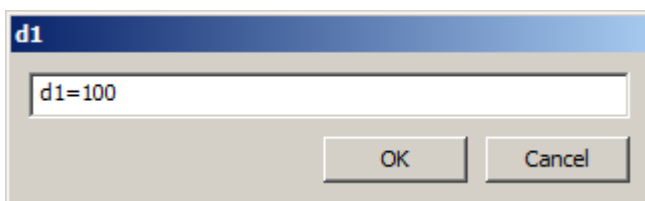

Also, the parametric size can be edited in "[Parameters Manager](#)".

**Allowable objects and dependency points**

- circle;
- arc.

**Angular**



Main menu: **Constraints - Parametric dimensions -  Angular.**



Ribbon: **Constraints - Parametric dimensions -  Angular.**



Toolbar: **Constraints -  Angular.**



Command line: **DCANGULAR.**

The command sets the angular dimensional relationship between the two straight lines.

**Procedure**

1. Call command  "**Angular**".

**Note:**

After the command is called, other dependency commands will be available in the context menu, which you can switch to if necessary. The list of dependencies is controlled by the switch "[Continuous add of constraints in manual mode](#)".



2. Determine how to insert an equalized size: 2 lines (by default when the command is called) or 3-3points. The method of insertion is determined by selecting the appropriate command from the context menu.

- **2 lines** - sets the angular size in two segments.

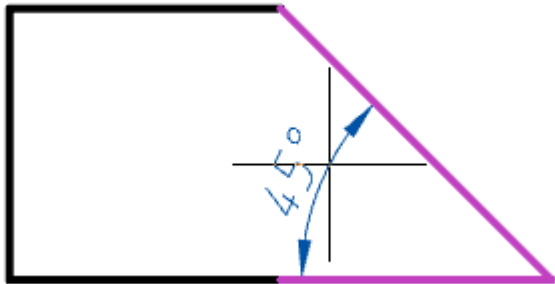

- **3-3points** - sets the angular dimension. First set the vertex of the angle, then the end points.

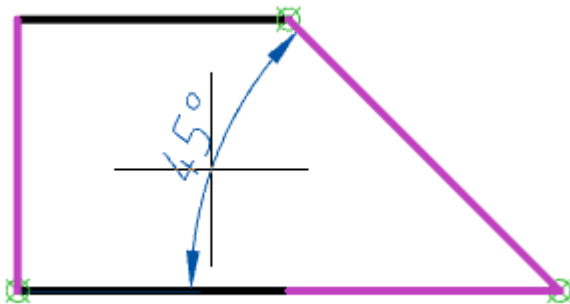

3. Specify the required objects, depending on the selected insertion method.

4. Place the parametric dimension on the drawing.

5. Parametric size will be built and added to the "[Parameters Manager](#)". A variable is assigned to the parameter dimension.

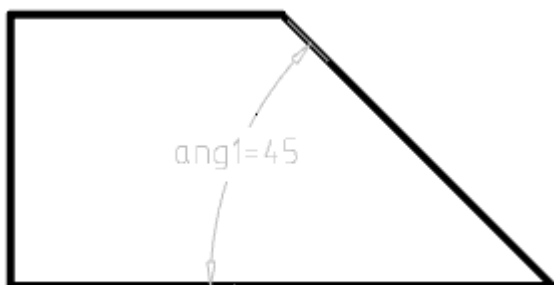

**Note:**

If the switch is on "[Continuous add of constraints in manual mode](#)", after applying the dependency, the system will automatically switch to the insertion of the following dependency. To exit the loop, press "**Esc**".

**Edit**

To edit the parametric size, double-click on the size. An editing dialog opens, where you can change the name of the variable and the value. The value can be a [formula](#).

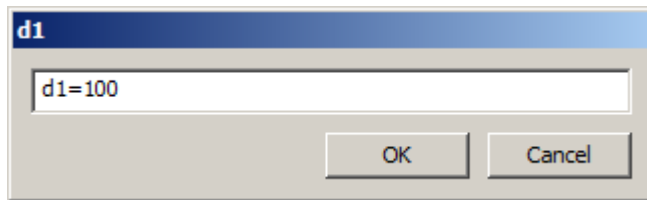

Also, the parametric size can be edited in ["Parameters Manager"](#).



### ***Allowable objects and dependency points***

- line segment;
- ectilinear segments of polylines;
- control points of objects;
- arc.

### ***Dimensional constraint***

 Main menu: **Constraints - Parametric dimensions -  Dimensional constraint.**

 Ribbon: **Constraints - Parametric dimensions -  Dimensional constraint.**

 Toolbar: **Constraints -  Dimensional constraint.**

 Command line: **DIMCONSTRAINT.**

The command converts simple dimensions to parametric.

### ***Procedure***

1. Set the dimensions.

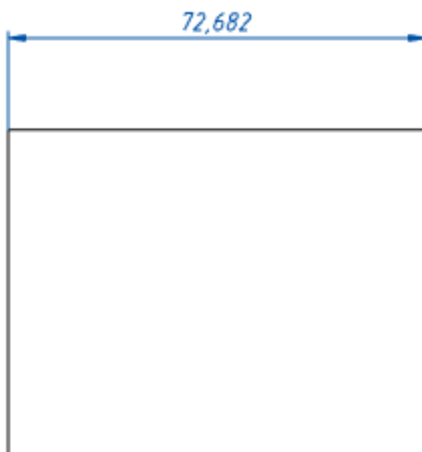

2. Call command  **"Dimensional constraint"** and specify the dimensions for conversion.

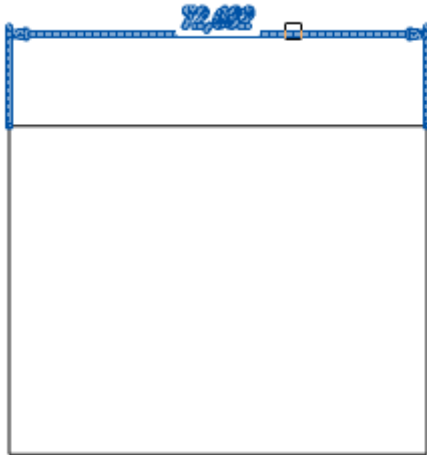

3. The specified dimensions are converted to parametric.



## *Parameters Manager*



Main menu: **Constraints -  $f_x$ Parameters Manager**.



Ribbon: **Constraints - Management -  $f_x$ Parameters Manager**.



Toolbar: **Constraints -  $f_x$ Parameters Manager**.



Command line: **PARAMETERS**.

### *Procedure*

1. Call command  $f_x$ "**Parameters Manager**". Open dialog "**Parameters Manager**".

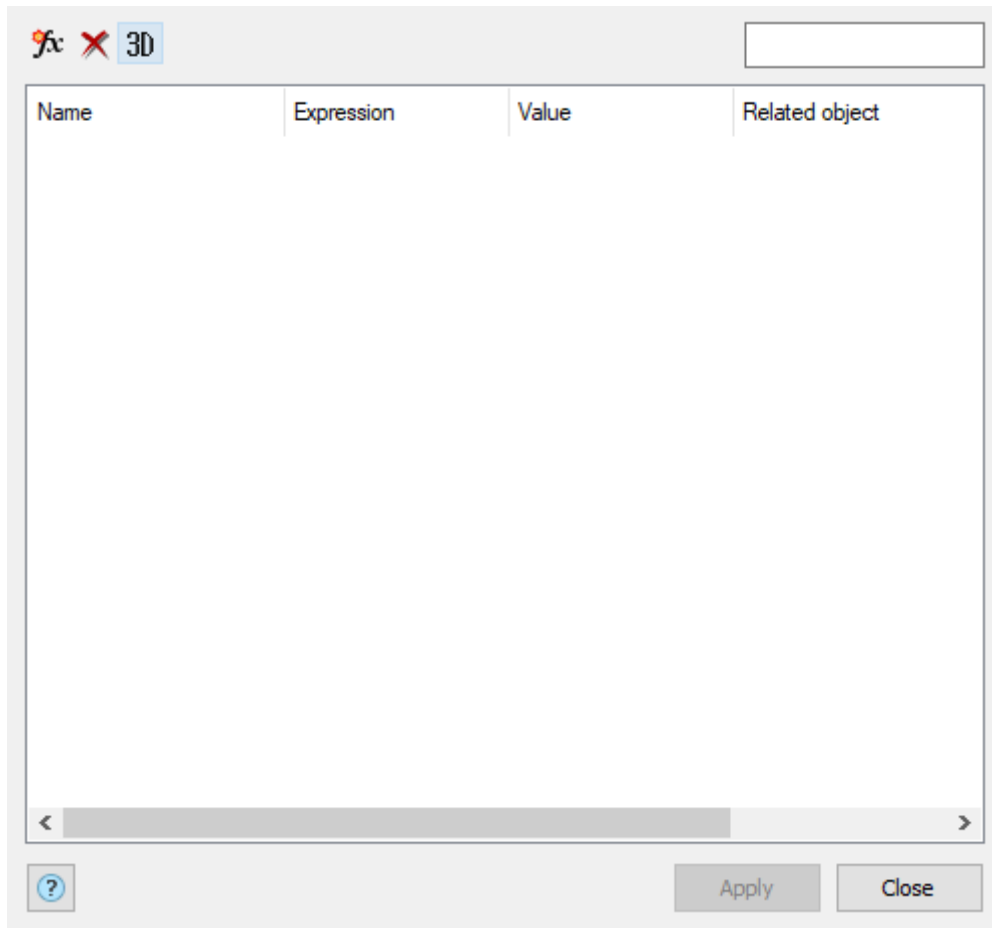

2. Edit the list of parameters.



The parameters in the list are divided into three sections:

- **User Parameters** - the parameters entered by the user are not tied to objects.
- **Dimensional Constraints** - dependencies imposed in the sketch using parametric dimensions.
- **Model parameters** - dependencies obtained as a result of 3D-design operations.

The list consists of four columns:

- **Name** - name of the parameter. You can edit.
- **Expression** - expression as a value or a formula that uses other parameters, operators, and functions. You can edit.
- **Value** - the final value when evaluating the expression. Not editable.
- **Related object** - the name of the object associated with the parameter. Not editable.

To manage the list, the following buttons are available:

-  **Create a new user parameter** - creates a new parameter that is not bound to objects.
-  **Delete the selected parameter** - removes any selected parameter.

**Important!**

Removing dimensional dependencies or model parameters, together with the parameter, the operation or dimensional dependence is deleted.

-  **Variables related to parametric 3D** - switch, controls the display of 2D and 3D parameters. When the toggle is on, the user parameters for 3D and "**Model parameters**" are displayed, when it is off, the user parameters for 2D and "**Dimensional Constraints**" are displayed.

To find the required parameter, you can use the filter in the upper right corner of the form.

3. Press button "**Close**".

## Using Dimensional Constraints

Let us create constraints for a circle and a rectangle based on 2 conditions:

Condition 1. Center of the circle is at the same point as a center of a rectangle.

Condition 2. The area of a circle is to equal to the area of a rectangle.

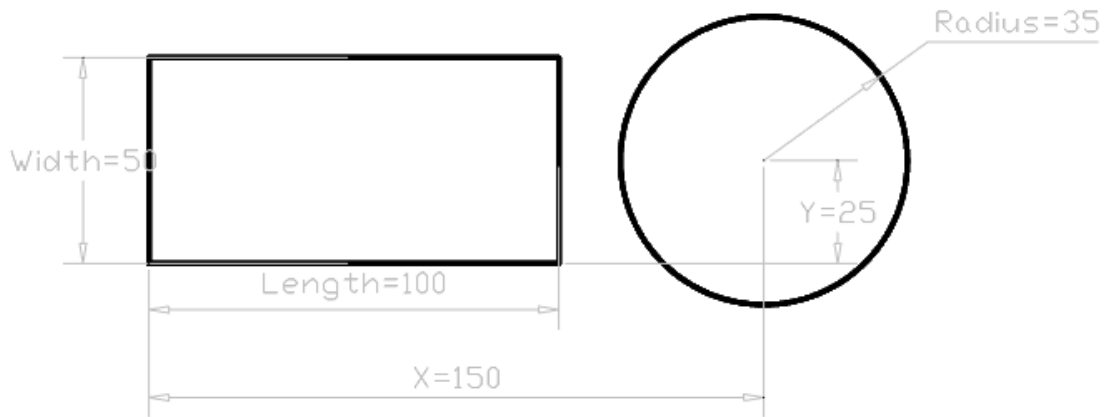

Let assign names to all dimensional constraints and set their relations.

At first we define an expression to place a center of a circle at the center of a rectangle.

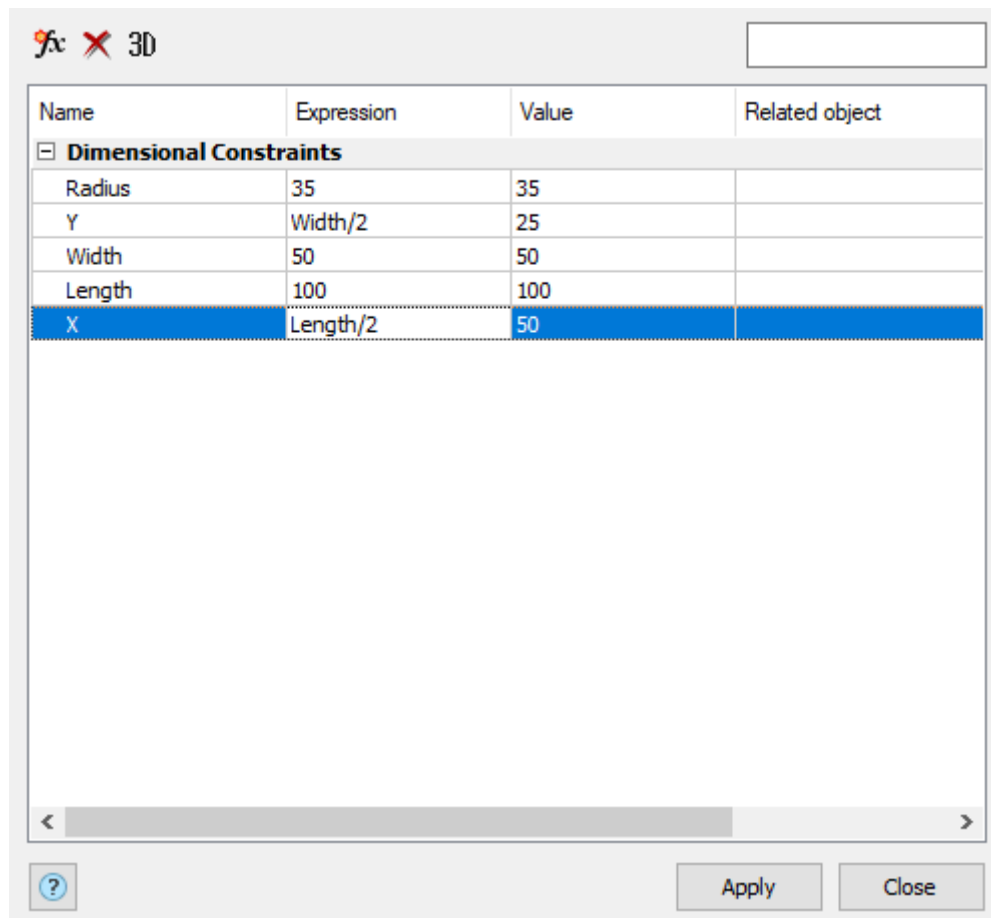

Name	Expression	Value	Related object
<b>Dimensional Constraints</b>			
Radius	35	35	
Y	Width/2	25	
Width	50	50	
Length	100	100	
X	Length/2	50	

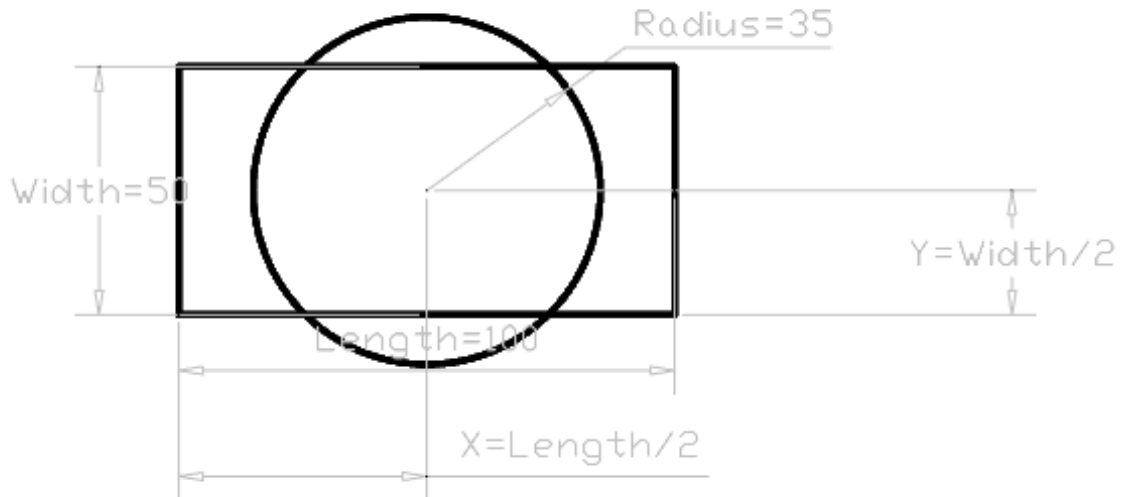

Now we define equality of areas of the circle and rectangle.  
To do this, we create an **Area** as user parameter.

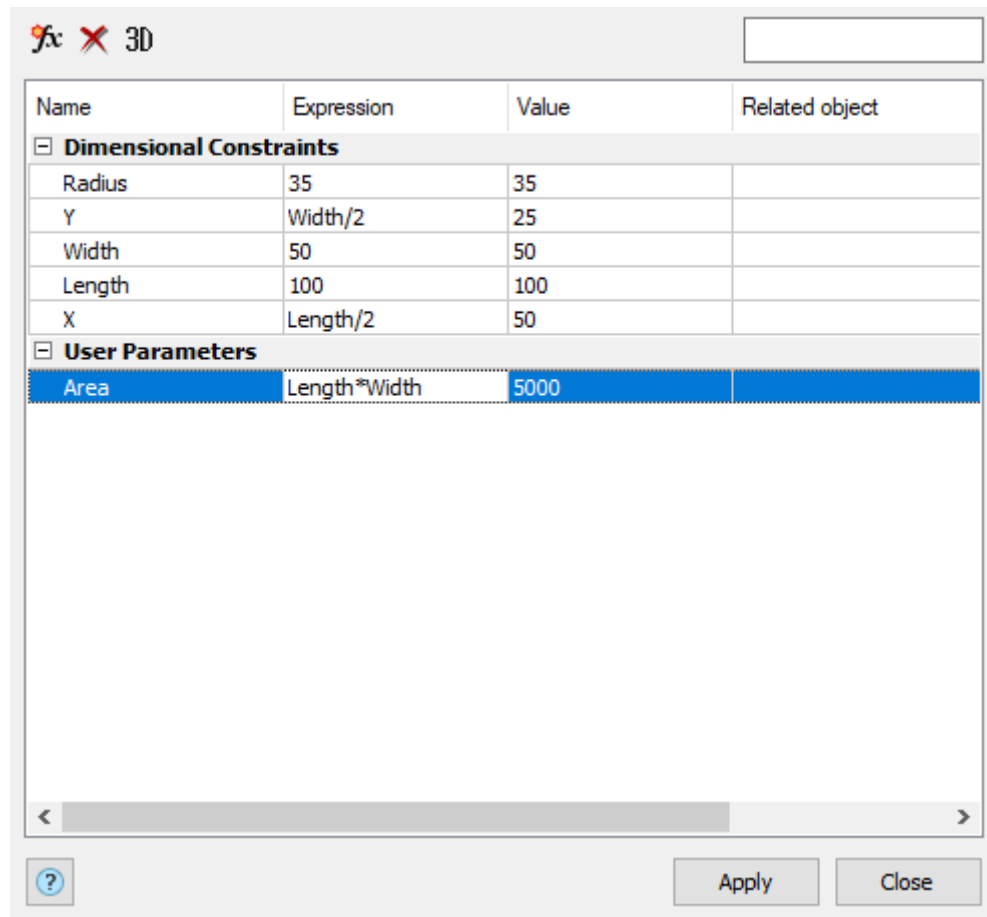

The screenshot shows the '3D' window in nanoCAD. It contains a table with the following data:

Name	Expression	Value	Related object
<b>Dimensional Constraints</b>			
Radius	35	35	
Y	Width/2	25	
Width	50	50	
Length	100	100	
X	Length/2	50	
<b>User Parameters</b>			
Area	Length*Width	5000	

At the bottom of the window, there are buttons for 'Apply' and 'Close', and a help icon (question mark) on the left.

Set an expression for a radius of the circle.

Name	Expression	Value	Related object
<b>Dimensional Constraints</b>			
Radius	$\text{sqrt}(\text{Area}/\text{PI})$	39.8942	
Y	$\text{Width}/2$	25	
Width	50	50	
Length	100	100	
X	$\text{Length}/2$	50	
<b>User Parameters</b>			
Area	$\text{Length}*\text{Width}$	5000	

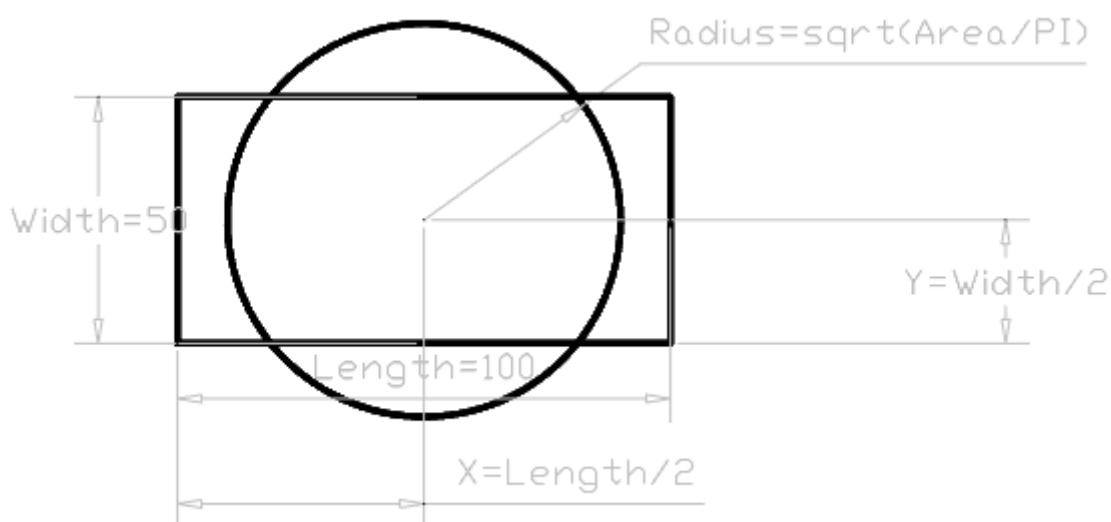

You could set equality of areas of the circle and the rectangle without definition of a user parameter by entering an expression for the Radius:  **$\text{sqrt}((\text{Length}*\text{Width})/\text{PI})$** .

## Operators and functions

### Operators

The following operators can be used in expressions:

Operator	Description
----------	-------------

Operator	Description
+	Addition
-	Substruction or Negative
%	Modulo or Remainder operator The expression "7 % 3" would evaluate to 1, because 7 divided by 3 leaves a quotient of 2 and a remainder of 1.
*	Multiplication
/	Division
^	Exponentiation
()	Round brackets
.	Decimal divider

Expressions are evaluated according to the standard mathematical rules of precedence:

1. Expressions within brackets; innermost sets first.
2. Standard operations order:
  - unary negation (negative value)
  - exponent
  - multiplication and division
  - addition and subtraction
3. Operators of equal precedence from left to right.

### Functions

The following functions can be used in expressions:

Function	Syntax
Cosine	cos ( <b>expression</b> )
Sine	sin ( <b>expression</b> )
Tangent	tan ( <b>expression</b> )
Arccosine	acos ( <b>expression</b> )
Arcsine	asin ( <b>expression</b> )
Arctangent	atan ( <b>expression</b> )
Hyperbolic cosine	cosh ( <b>expression</b> )
Hyperbolic sine	sinh ( <b>expression</b> )
Hyperbolic tangent	tanh ( <b>expression</b> )
Hyperbolic arccosine	acosh ( <b>expression</b> )
Hyperbolic arcsine	asinh ( <b>expression</b> )
Hyperbolic arctangent	atanh ( <b>expression</b> )
Square root	sqrt ( <b>expression</b> )
Signum-function (-1, 0, 1)	sign ( <b>expression</b> )
Round to nearest integer	round ( <b>expression</b> )
Truncate decimal	trunc ( <b>expression</b> )
Round down	floor ( <b>expression</b> )



Function	Syntax
Round up	ceil ( <b>expression</b> )
Absolute value	abs ( <b>expression</b> )
Largest element in array	max ( <b>expression 1</b> ; <b>expression 2</b> )
Smallest element in array	min ( <b>expression 1</b> ; <b>expression 2</b> )
Degrees to radians	d2r ( <b>expression</b> )
Radians to degrees	r2d ( <b>expression</b> )
Logarithm, base <b>e</b>	ln ( <b>expression</b> )
Logarithm, base <b>10</b>	log ( <b>expression</b> )
Exponent, base <b>e</b>	exp ( <b>expression</b> )
Exponent, base <b>10</b>	exp10 ( <b>expression</b> )
Power function	pow ( <b>expression 1</b> ; <b>expression 2</b> )
Random decimal, 0-1	Random

## Auto constrain



Main menu: **Constraints** -  **Auto constrain**.



Ribbon: **Constraints** - **Geometric** -  **Auto constrain**.





Toolbar: **Constraints** -  **Auto constrain**.



Command line: **AUTOCONSTRAIN**.

The command automatically sets constraints depending on the geometry.

## Procedure

1. Call command  **"Auto constrain"**.
2. Select objects to overlay dependencies. You can choose a secant frame. If the objects were selected before the command is called  **"Auto constrain"**, the process of selecting objects is skipped.

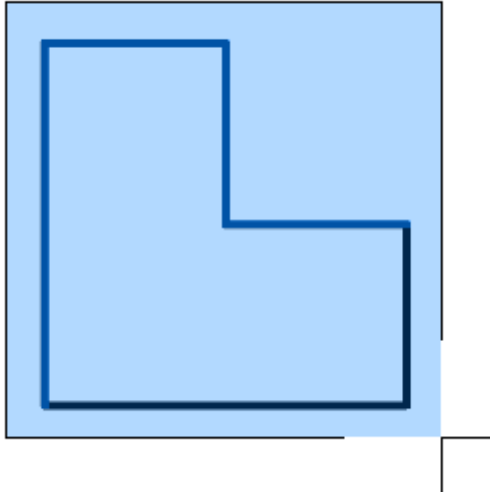

3. Press **"Enter"** to complete the selection of objects. The system automatically imposes the necessary dependencies.

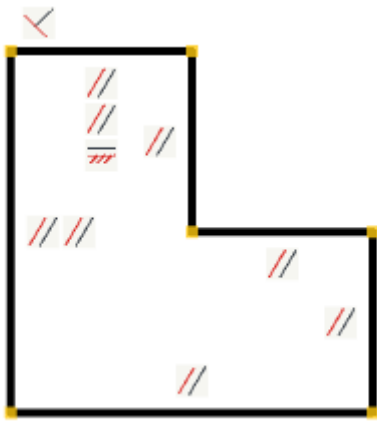

## ***Constraint settings***

 Main menu: **Constraints** -  **Constraint settings**.

 Toolbar: **Constraints** -  **Constraint settings**.

 Command line: **CONSTRAINTSETTINGS**.

## ***Procedure***

1. Call command  **"Constraint settings"**. Open dialog **"Constraint Settings"**.

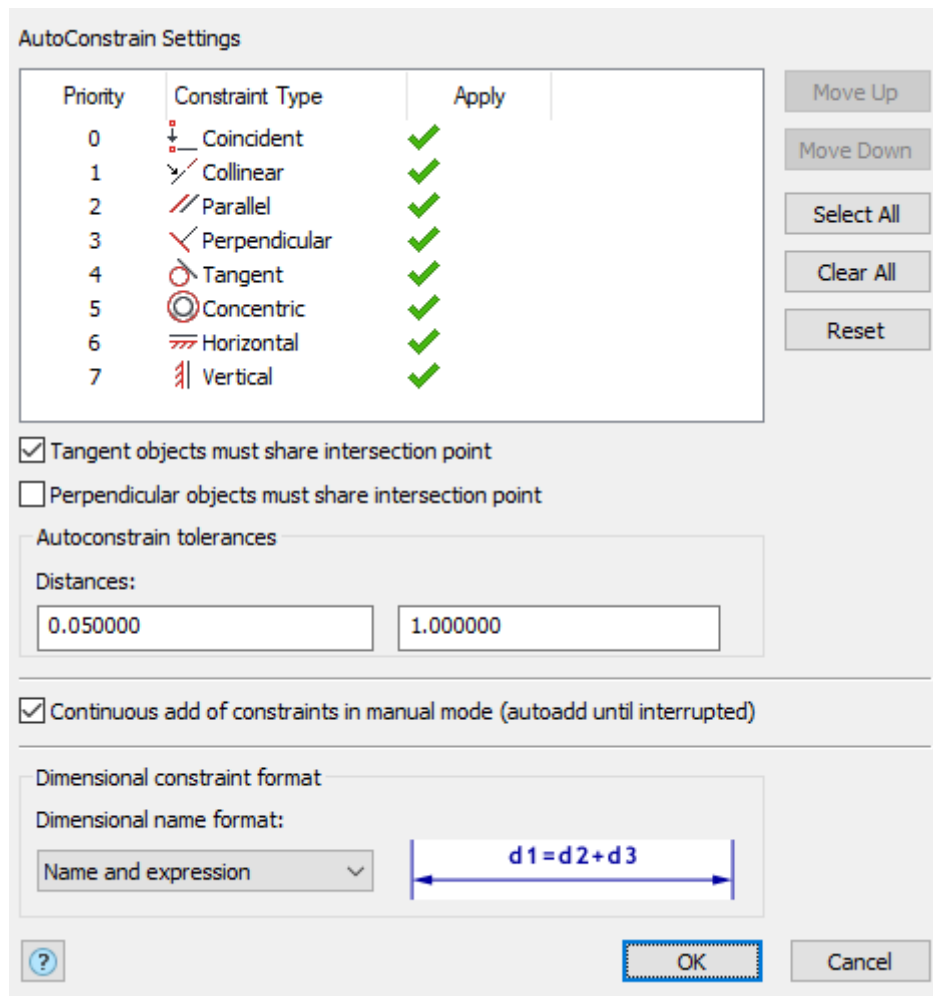

## 2. Configure the dependencies:

- List "AutoConstrain Settings" - allows you to set the type of dependencies and the order of their overlapping. In the "Apply" column, clicking the LMB adjusts the activity of the dependency types. Active dependency types can be used in auto-imposed dependencies.

The list is supplemented with control buttons:

- **Move up** - moves the selected dependency type higher in the list (increases the priority).
- **Move down** - moves the selected dependency type lower in the list (lowers the priority).
- **Select all** - makes all dependency types active.
- **Clear all** - makes all dependency types inactive.
- **Reset** - demand settings to the original settings.
- Switch "**Tangent objects must share intersection point**" - controls the condition that autotuning "Tangent" will occur only for objects with a common point.
- Switch "**Perpendicular objects must share intersection point**" - controls the condition that the "Perpendicular" autoconfiguration will occur only for objects with a common point.
- Field group "**Autoconstrain tolerances**":
  - **Distances** - the maximum allowable distance between control points for automatic alignment.
  - **Angles** - the maximum angle between objects for automatic superposition of perpendicularity and parallelism.
- Switch "**Continuous add of constraints in manual mode (autoadd until interrupted)**" - controls the cyclic mode of overlay dependencies, as well as a list of dependencies in the context menu when the dependency is called.

- List **Dimensional constraint format** - controls the display of the name of the dimension dependency in the drawing. When you select a format to the right of the list, its display example is displayed.

Possible options:

- **Name** - displays only the name of the dimension dependency.
- **Value** - displays the magnitude of the dimensional dependence.
- **Name and expression** - displays the name of the dimension relation, as well as the parametric expression of the dependency. If no parametric expression is imposed on the dependence, then **Expression=Value**.

3. Press button **"OK"** to confirm the change of settings. The **"Constraint Settings"** dialog box closes.

## Show/hide constraints



Main menu: **Constraints** -  **Show/hide constraints**.



Ribbon: **Constraints - Management** -  **Show/hide constraints**.



Toolbar: **Constraints** -  **Show/hide constraints**.



Command line: **SHOWHIDECTRS**.

### Procedure

1. Call command  **"Show/hide constraints"**. If the dependencies were hidden - they will be shown, if displayed - hidden.

## Delete constraints



Main menu: **Constraints** -  **Delete constraints**.



Ribbon: **Constraints - Management** -  **Delete constraints**.



Toolbar: **Constraints** -  **Delete constraints**.



Command line: **DELCONSTRAINT**.

The command removes dependencies from the selected object.

### Procedure

1. Call command  **"Delete constraints"**.
2. Specify the dependencies or objects for which you want to remove dependencies.
3. Press the **"Enter"** key. The selected dependencies, all dependencies of the selected objects, and the dependencies associated with these objects are deleted.

#### Note:

When you add a **"Coincident"** dependency, this dependency is displayed by a dot, not by an icon. At the same time, there can be several alignment relationships at one point. To remove such dependencies, in the delete dependencies mode, move the mouse cursor over the dependency point. In this case, the entire set of coincidents will unfold at this point. You can delete any of them.

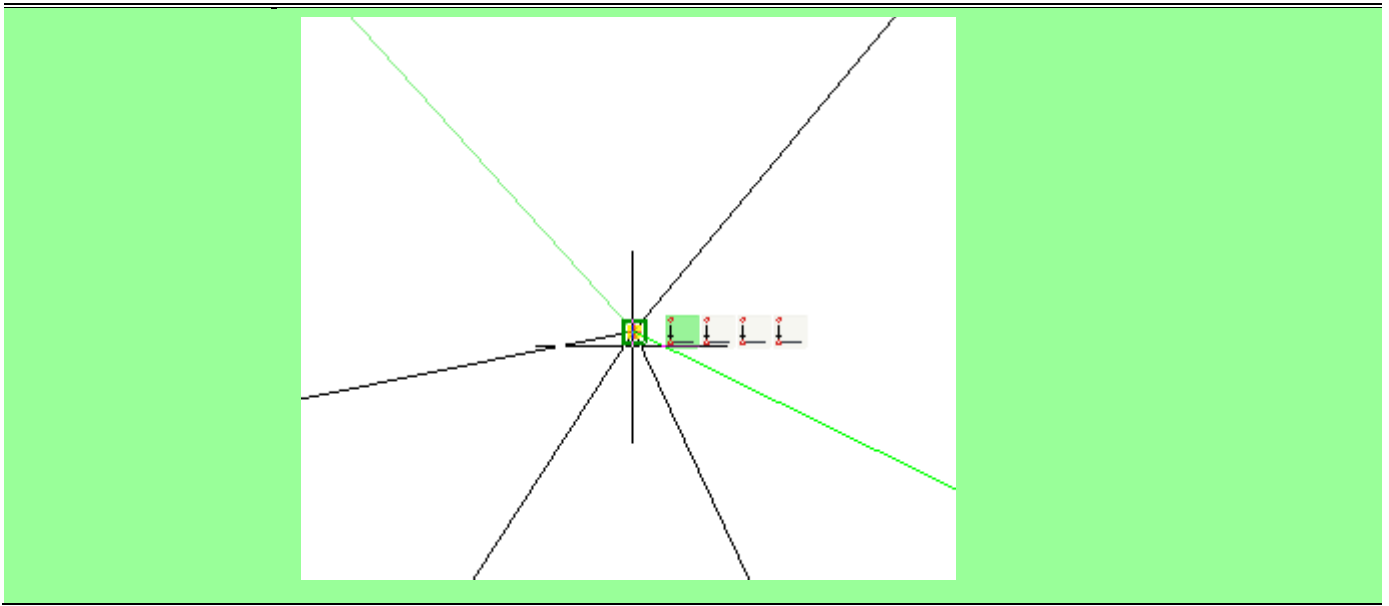

## Light Sources

By default, in visual styles supporting shading, the model space is illuminated with one or two light sources always placed near the view point (as if behind the viewer). I.e. the lighting moves along with the viewpoint and always highlight the visible object.

It is possible to create in the model space own light sources of four types:

- [Point light](#);
- [Spotlight](#);
- [Distant light](#);
- [Weblight](#).

After creating the light, the default highlighting is turned off and the screen is illuminated only with the lights created in it. After removal of all lights, the highlighting is turned on again.

Each of the lights has general and specific parameters, which can be regulated on the **Properties** functional panel.

Lights that have no visual representation, such as **Distant light**, can be selected in the **Drawing Explorer**.

### Point Light



Ribbon: **View – Render – Create Light >**  **Point**



Menu: **View – Render – Light >**  **New point light**



Toolbar: **Lights –** 



Command line: **POINTLIGHT**

Creates the omni point light that simulates the light bulb.

The source is displayed in the work space as a small sphere contour.

### Command prompts:

Set the light source location:

Define the point of the light source location.

Set the target location:

Define the point of the target location – the point to which the light flux will be directed.

Enter the name of the modified mode or [Name/Intensity/Status/Photometry/Attenuation/Color/Exit]:

Define the command options, if necessary, otherwise just press **ENTER**.

### Command options:

<u>Name</u>	Name of the light source.
<u>Intensity</u>	Brightness of the light: from 0 to the maximum value supported. By default, is equal to 1.
<u>Status</u>	Status of the light source: turned on/off. The disabled light source stops lighting, and its icon in the work space changes color to bright green.
<u>Photometry</u>	<p>Photometry is the measurement of the luminous intensities of visible light sources.</p> <ul style="list-style-type: none"> <li>• <b>Intensity</b> of light in photometry is the measurement of perceived power emitted by a light source in a particular direction. <ul style="list-style-type: none"> <li>• <b>Flux</b> – perceived power.</li> <li>• <b>Illuminance</b> – the general light flux per surface per area unit.</li> </ul> </li> <li>• <b>Color</b> – color of light given by this source <ul style="list-style-type: none"> <li>• <b>Color name</b> – lamp color name from the list of standard colors.</li> <li>• <b>?</b> – displays the list of color names.</li> <li>• <b>Kelvin</b> – Kelvin color temperature value (min:1000 - max:20000).</li> </ul> </li> </ul> <p>The option is available only if values 1 or 2 are set for the LIGHTINGUNITS system variable.</p>
<u>Attenuation</u>	<p>Diminishing the light intensity (brightness) over distance from the light source.</p>

#### Attenuation type:

- **None** – sets no attenuation. Objects that are both far and close to the light source are illuminated equally.
- **Inverse linear** – sets attenuation value to be the inverse of the linear distance from the light to the object. By default, the intensity at inverse linear is half the maximum intensity.
- **Inverse squared** – sets attenuation value to be the inverse of square of the distance from the light to the object.

**Use limits** – Turns on and off the attenuation limits.

- **Attenuation start limit** – specifies the point where light starts as an offset from the center of the light. By default, is

determined as 0.

- **Attenuation end limit** – specifies the point the light ends as an offset from the center of the light. No light is cast beyond this point.

Impact of this option is not taken into account if the value of LIGHTINGUNITS system variable is different from 0.

### Color

Color of light given by this source.

- **R,G,B** – colors in accordance with RGB color model.
- **Color index** – nanoCAD color index.
- **H,S,L** – colors according to HSL color model.

### Exit

Exits the command.

## Spotlight

 Ribbon: **View – Render – Create Light >**  **Spot**

 Menu: **View – Render – Light >**  **New spotlight**

 Toolbar: **Lights –** 

 Command line: **SPOTLIGHT**

Creates focused source of light that simulates flashlight or headlight.

Spotlight is displayed in the work space as a flashlight icon with two emitted light cones. An internal cone displays borders of light of permanent brightness, external one determines borders of fade in light intensity.

### Command prompts:

Set the light source location:

Define the point of the light source location.

Set the target location:

Define the point of the target location – the point to which the light flux will be directed.

Enter the name of the modified mode or  
[Name/Intensity/Status/Photometry/Spot/Fall  
off/Attenuation/Color/Exit]:

Define the command options, if necessary, otherwise just press **ENTER**.

### Command options:

Name Name of the light source.

Intensity Brightness of the light: from 0 to the maximum value supported. By default, is equal to 1.

Status Status of the light source: turned on/off. The disabled light source stops lighting, and its icon in the work space changes color to bright green.

Photometry Photometry is the measurement of the luminous intensities of visible light sources.

- **Intensity** of light in photometry is the measurement of perceived power emitted by a light source in a particular direction.
  - **Flux** – perceived power.
  - **Illuminance** – the general light flux per surface per area unit.
- **Color** – color of light given by this source
  - **Color name** – lamp color name from the list of standard colors.
  - **?** – displays the list of color names.
  - **Kelvin** – Kelvin color temperature value (min:1000 - max:20000).

The option is available only if values 1 or 2 are set for the LIGHTINGUNITS system variable.

#### Hotspot

Angle of the light beam that defines the size of the inside light cone of the same brightness equal to the value of **Intensity** parameter. The angle value can be in the range from 0 to 160 degrees (45 by default).

#### Falloff

Angle that defines the size of external cone of light (full cone of light). Internal and external cones define the area of Falloff, in which brightness from this light source falls from maximum to 0.

The angle can range from 0 to 160 degrees (by default 50). The falloff angle should be greater or equal to the hotspot angle.

#### Attenuation

Diminishing the light intensity (brightness) over distance from the light source.

##### **Attenuation type:**

- **None** – sets no attenuation. Objects that are both far and close to the light source are illuminated equally.
- **Inverse linear** – sets attenuation value to be the inverse of the linear distance from the light to the object. By default, the intensity at inverse linear is half the maximum intensity.
- **Inverse squared** – sets attenuation value to be the inverse of square of the distance from the light to the object.

**Use limits** – Turns on and off the attenuation limits.

- **Attenuation start limit** – specifies the point where light starts as an offset from the center of the light. By default, is determined as 0.
- **Attenuation end limit** – specifies the point the light ends as an offset from the center of the light. No light is cast beyond this point.

Impact of this option is not taken into account if the value of LIGHTINGUNITS system variable is different from 0.

#### Color

Color of light given by this source.

- **R,G,B** – colors in accordance with RGB color model.
- **Color index** – nanoCAD color index.
- **H,S,L** – colors according to HSL color model.

#### Exit

Exits the command.



## Distant Light

-  Ribbon: **View – Render – Create Light >**  **Distant**
-  Menu: **View – Render – Light >**  **New distant light**
-  Toolbar: **Lights –** 
-  Command line: **DISTANTLIGHT**

Creates the distant light source simulating light from the sun or other far objects.

This source has no visual display in the work space, therefore it is convenient to select it from the **Drawing Manager** functional panel, with further editing of properties on the **Properties** panel.

### Command prompts:

- |  |  |
|--|--|
| Set the light direction FROM:  | Define the first point for setting direction of the light flux.                |
| Set the light direction TO:  | Define the second point for setting direction in which the light flux will go. |
| Enter the name of the modified mode or<br>[Name/Intensity/Status/Photometry/Color/Exit]<br>: | Define the command options, if necessary, otherwise just press <b>ENTER</b> .  |

### Command options:

- |                   |   |
|-------------------|---|
| <u>Name</u>       | Name of the light source.   |
| <u>Intensity</u>  | Brightness of the light: from 0 to the maximum value supported. By default, is equal to 1.  |
| <u>Status</u>     | Status of the light source: turned on/off. The disabled light source stops lighting.  |
| <u>Photometry</u> | Photometry is the measurement of the luminous intensities of visible light sources. <ul style="list-style-type: none"> <li>• <b>Intensity</b> of light in photometry is the measurement of perceived power emitted by a light source in a particular direction. <ul style="list-style-type: none"> <li>• <b>Flux</b> – perceived power.</li> <li>• <b>Illuminance</b> – the general light flux per surface per area unit.</li> </ul> </li> <li>• <b>Color</b> – color of light given by this source <ul style="list-style-type: none"> <li>• <b>Color name</b> – lamp color name from the list of standard colors.</li> <li>• <b>?</b> – displays the list of color names.</li> <li>• <b>Kelvin</b> – Kelvin color temperature value (min:1000 - max:20000).</li> </ul> </li> </ul> |

The option is available only if values 1 or 2 are set for the LIGHTINGUNITS system variable.

Color

Color of light given by this source.

- **R,G,B** – colors in accordance with RGB color model.
- **Color index** – nanoCAD color index.
- **H,S,L** – colors according to HSL color model.

Exit

Exits the command.

## Weblight

-  Ribbon: **View – Render – Create Light >**  **Web Light**
-  Menu: **View – Render – Light >**  **New Web Light**
-  Toolbar: **Lights –** 
-  Command line: **WEBLIGHT**

Creates an accurate 3D representation of light intensity distribution for the light source.

### Command prompts:

Set the light source location:

Define the point of the light source location.

Set the target location:

Define the point of the target location – the point to which the light flux will be directed.

Enter the name of the modified mode or [Name/Intensity/Status/Photometry/Web/Attenuation/Color/Exit]:

Define the command options, if necessary, otherwise just press **ENTER**.

### Command options:

Name

Name of the light source.

Intensity

Brightness of the light: from 0 to the maximum value supported. By default, is equal to 1.

Status

Status of the light source: turned on/off. The disabled light source stops lighting.

Photometry

Photometry is the measurement of the luminous intensities of visible light sources.

- **Intensity** of light in photometry is the measurement of perceived power emitted by a light source in a particular direction.
  - **Flux** – perceived power.
  - **Illuminance** – the general light flux per surface per area unit.
- **Color** – color of light given by this source

- **Color name** – lamp color name from the list of standard colors.
- **?** – displays the list of color names.
- **Kelvin** – Kelvin color temperature value (min:1000 - max:20000).

The option is available only if values 1 or 2 are set for the LIGHTINGUNITS system variable.

#### Web

Specifies the light intensity at points on a spherical grid.

- **File** – specifies the file with **.ies** extension, which should be used to define the properties of the web.
- **X** – specifies the X rotation for the web.
- **Y** – specifies the Y rotation for the web.
- **Z** – specifies the Z rotation for the web.

#### Attenuation

Diminishing the light intensity (brightness) over distance from the light source.

##### **Attenuation type:**

- **None** – sets no attenuation. Objects that are both far and close to the light source are illuminated equally.
- **Inverse linear** – sets attenuation value to be the inverse of the linear distance from the light to the object. By default, the intensity at inverse linear is half the maximum intensity.
- **Inverse squared** – sets attenuation value to be the inverse of square of the distance from the light to the object.

**Use limits** – Turns on and off the attenuation limits.

- **Attenuation start limit** – specifies the point where light starts as an offset from the center of the light. By default, is determine as 0.
- **Attenuation end limit** – specifies the point the light ends as an offset from the center of the light. No light is cast beyond this point.

Impact of this option is not taken into account if the value of LIGHTINGUNITS system variable is different from 0.

#### Color

Color of light given by this source.

- **R,G,B** – colors in accordance with RGB color model.
- **Color index** – nanoCAD color index.
- **H,S,L** – colors according to HSL color model.

#### Exit

Exits the command.

## Coverings

Coverings are used to improve visualization of three-dimensional objects and scenes. They make objects look more realistic. A covering as a nanoCAD object is a set of settings and textures that determine the appearance of surface of three-dimensional objects and imitate real materials. As a result of covering application, an object can look like made of wood, plastic, metal, be glossy or mat, have a complex texture or not reflect light at all.



Coverings can be viewed, edited and assigned to objects.

## *Coverings Browser*

The Coverings Browser displays all coverings in a document, allows you to create, edit and assign coverings to drawing objects.



Ribbon: **Manage – Palettes** >  **Coverings Browser**



Ribbon: **View – Render** >  **Coverings Browser**



Menu: **View – Render** >  **Coverings Browser**



Menu: **View – Toolbars – Functional** >  **Coverings Browser**



Command line: **COVERINGBROWSER**

The Coverings Browser is displayed as a toolbar containing all coverings of the current documents.

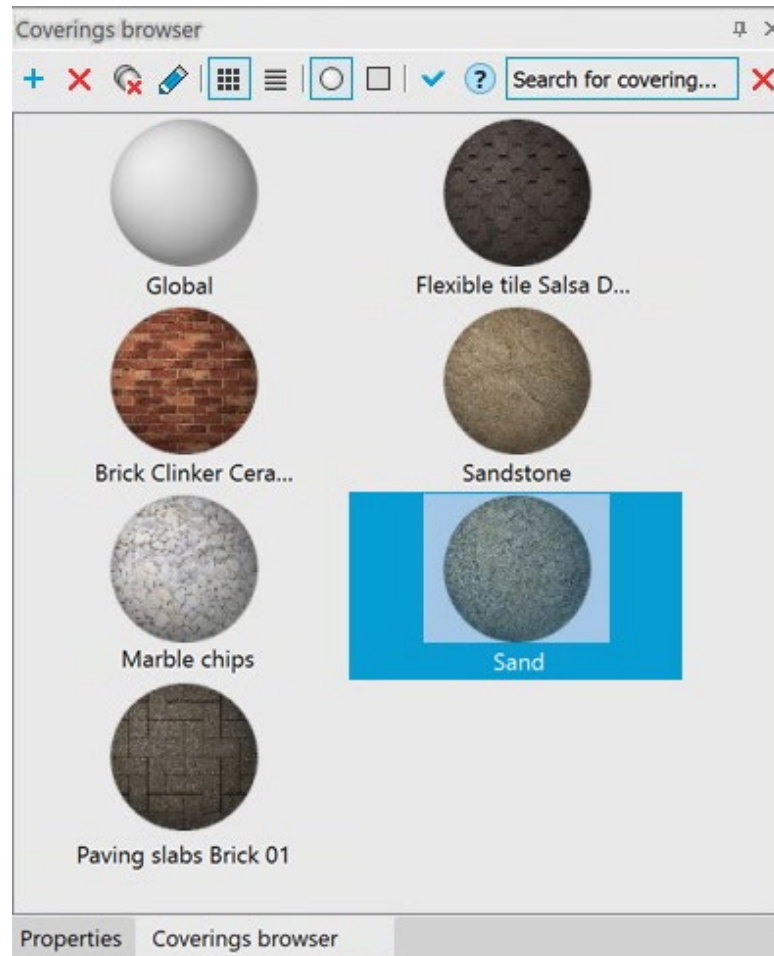

### Options:



Creates a new material with a set of default properties. Name of the new invoice *Default Generic (N)*, where *N* is the sequential number of the created covering. The name can be changed by the **Rename** command in the context menu of the selected covering.



Deletes the selected covering. Multiple coverings can be selected by using the **SHIFT** and **CTRL** keys.





Deletes all coverings in the browser except Global.





Edits the selected covering.



Changes the format for presenting coverings as icons  or as a list .



Changes the display of coverings on a sphere  or a plane .



Applies the selected covering to objects selected in the drawing. Double-clicking a covering also applies it to the selected objects.

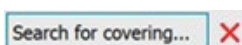

The field to seek for a covering by name. The  field button resets the search results.

Right click on a covering opens the context menu with an additional list of available actions:

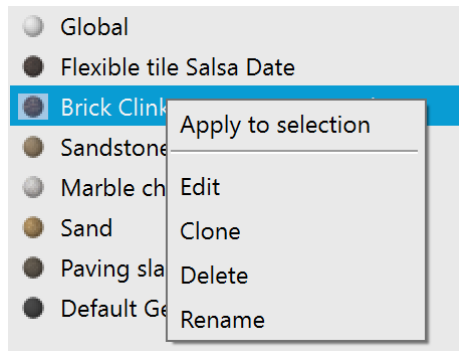

### Apply to selection

Applies a covering to selected three-dimensional objects of the workspace or individual faces of three-dimensional objects. Individual faces of objects can be selected while holding down the **CTRL** key.

### Edit

Edits a covering in the [Coverings browser](#).

### Clone

Creates a new covering identical to this sample.

### Delete

Deletes a covering.

### Rename

Changes the covering's name.

The name should contain at least one character. Names should not be duplicated. Inappropriate characters for a covering name are: < > / \ " " : ; ? \* | , = ` .

3D Visualization	
Material	ByLayer
Visual style	<b>ByLayer</b>
<b>Pattern</b>	ByBlock
Type	Global
Pattern name	Flexible tile Salsa Date
Angle	Brick Clinker Ceramic (Natural)
Scale	Sandstone
Origin X	Marble chips
Origin Y	Sand
Spacing	Paving slabs Brick 01
Double	Default Generic
	1.0000
	No

It is possible to assign a material to the selected object not only in the **Coverings Browser**, but also on the **Properties** bar in the drop-down list of the **Covering** parameters.

## Coverings Library

You can add coverings to your drawing from the Coverings Library, which is available as a separate section in the [File Explorer](#). There you can view the coverings of the library and add them to the current document by double-clicking or using the context menu command. Using drag and drop into the drawing area, it is possible to add several coverings at once.

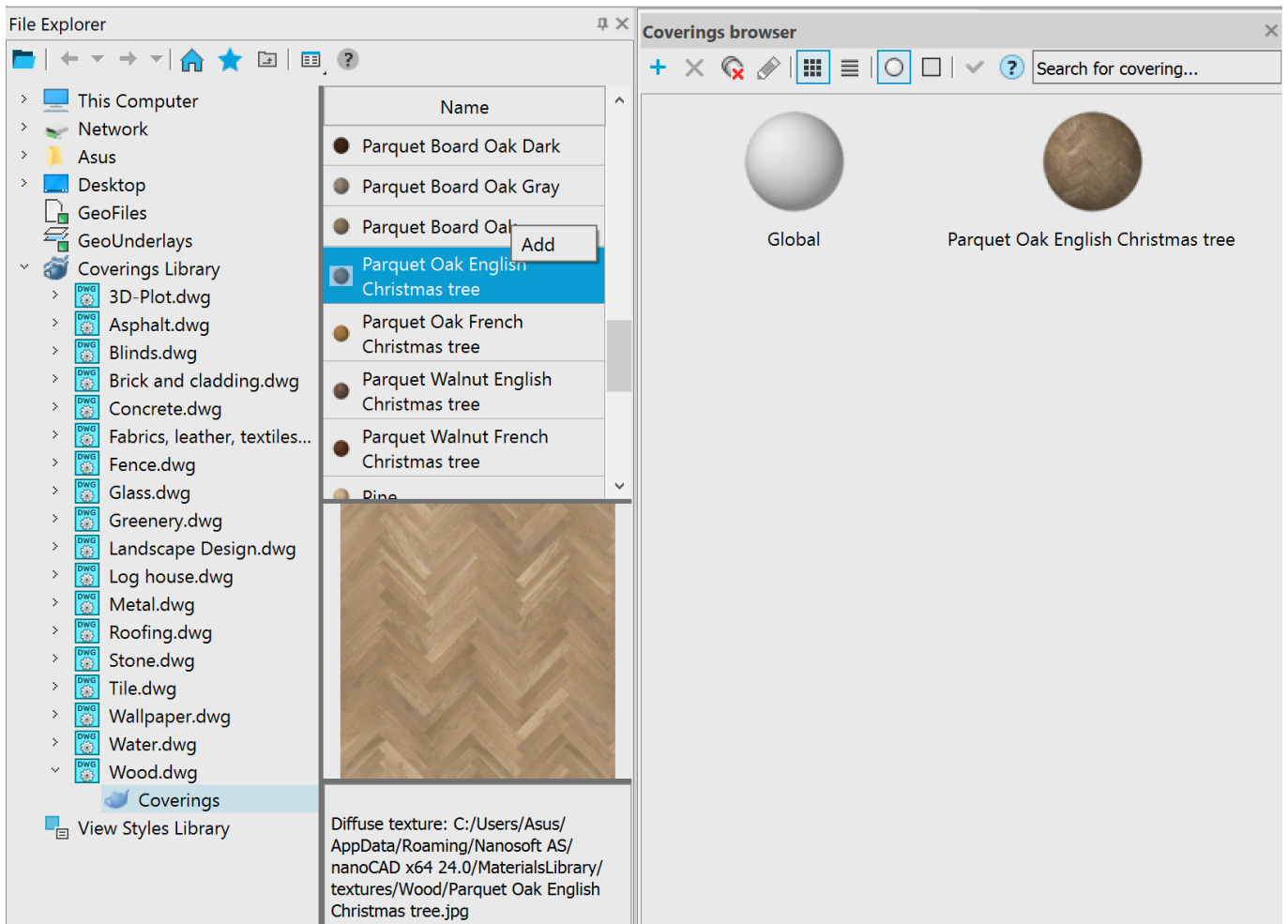

By default, the coverings library is located in the folder C:\Users\Username\AppData\Roaming\Nanosoft AS\nanoCAD 24.0\CoveringsLibrary\. You can change its location in the **Default directories** section of the **Options** dialog. There is also an option to add custom coverings libraries.

## Coverings Editor



Double click on the covering in the **Coverings Browser**



Context menu of the covering in the **Coverings Browser: Edit...**

**Coverings editor** allows you to edit parameters of the covering selected in the **Coverings Browser** and open the **Texture editor** bar to edit texture.

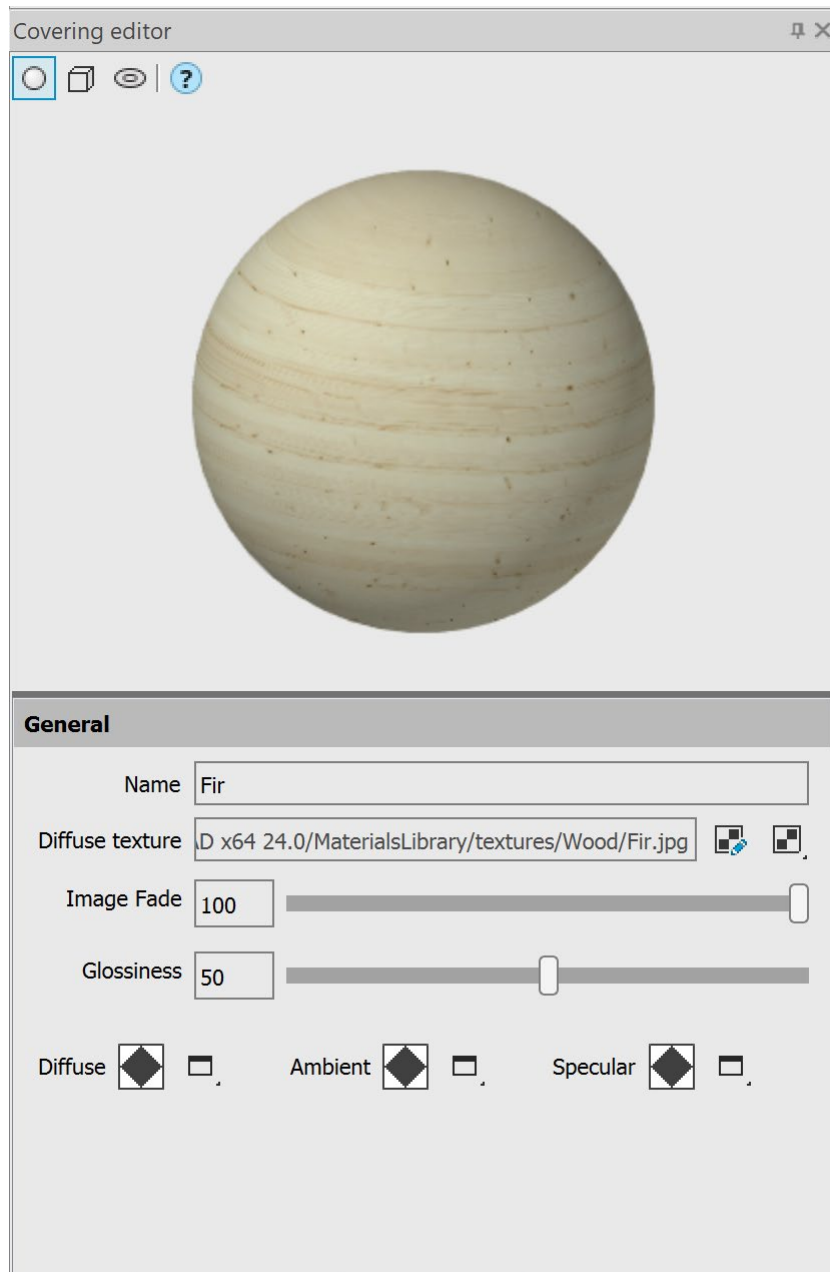

Selection of 3D object in the preview window to evaluate the resulting material. The object can be zoomed in, removed and rotated using the mouse.

**Name**

Field to specify the covering's name.

**Diffuse texture**

Displays the path where the image texture file is located.



Opens/Closes the Texture Editor toolbar.



Selects and edits an image texture file.

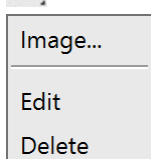



Image – selects a new texture file for this covering. It is possible to use image formats \*.jpg, \*.jpeg, \*.tiff, \*.tif, \*.bmp, \*.png.

Edit – opens the Texture Editor toolbar to edit a texture. The item becomes available only after selecting a texture file using the Image item.

Delete – deletes the link to the texture file for this covering (do not use a texture in this covering).



<b>Image fade</b>	Specifies a percentage value (from 0 to 100) by entering into the field or indicating by the slider.
<b>Vector texture</b>	Displays the path where the vector texture file is located.
	Creates and selects a vector texture file. Create - Select existing - selects a texture from the list of previously created one. Delete - deletes a link to the texture file for this covering (do not use a texture in this covering).
<b>Glossiness</b>	Specifies the size of the texture glossiness by entering in the field or indicating by the slider (from 0 to 100).
<b>Diffuse</b>	The color of the illuminated part of the object (diffuse color). If By Object is selected, the diffuse color will be inherited from the object to which the covering is applied.
<b>Ambient</b>	The color of an object in the shadow area (ambient color), i.e. in an area not illuminated by direct rays. Usually, the highlight color is a very dark shade of the diffuse color. If By object is selected, the highlight color will be inherited from the object to which the covering is applied.
<b>Specular</b>	Specular color. If By object is selected, the specular color will be inherited from the object to which the covering is applied.

## ***Texture Editor***

The texture editor allows you to configure texture parameters for the edited covering: position it on the surface of an object, specify scaling and repetition parameters, and the method of applying it to the object. Changes you make to the parameters are displayed in the preview area of the **Texture Editor**.

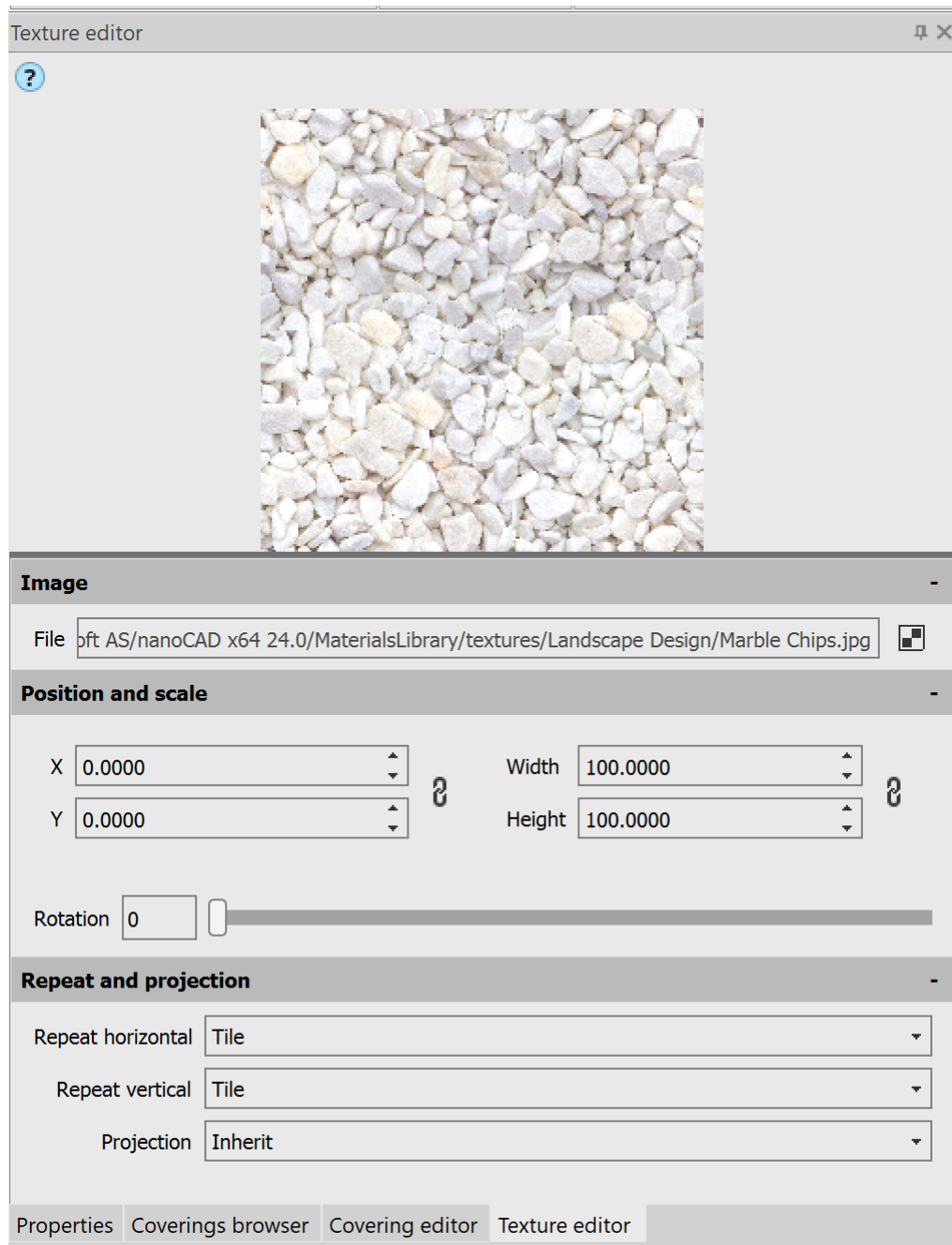

### Image

#### File



Displays the path where the raster texture file is located.

Selects a new texture file.

### Position and scale

#### X Y

Offset of the base point of the texture along the X and Y axis.



– button for synchronizing horizontal and vertical offset.

#### Width Height

Image dimensions in width and height.



– button for maintaining proportions; when the width changes, the height also changes, and vice versa.



#### Rotation

Specifies the raster rotation angle by entering value into the field or indicating by the slider (from 0 to 360).

### *Repeat and projection*

<b>Repeat horizontal</b>	Selects the pattern for filling the surface with texture horizontally and vertically: <b>Clamp, Crop, Inherit, Mirror, Tile.</b>
<b>Repeat vertical</b>	
<b>Projection</b>	The method of projecting texture onto a surface. An option that allows you to best select the texture overlay depending on the object's shape: <b>Box, Cylinder, Inherit, Planar, Sphere.</b>



### *To create a new covering:*

1. Open the **Coverings Browser** functional bar (**COVERINGBROWSER**).
2. On the toolbar, click the  **New Covering** button. To create a covering based on an existing one, right-click on it and select the **Clone** command in the context menu.
3. If necessary, rename the created covering by right-clicking on it and selecting the **Rename** command in the context menu.
4. To go to the **Covering Editor**, right-click on the created texture and select the **Edit...** command in the context menu.
5. In the **Covering Editor** toolbar, set the necessary covering parameters, monitoring the result in the preview window.
6. To set the texture, click the  **Image...** button and specify the path to the image texture file.
7. By clicking the  button, go to the **Texture editor** toolbar and edit the necessary texture parameters.









### *To apply the covering:*

1. Select objects in the drawing. To select the face of an object, use **CTRL**.
2. Select a covering in the bar and click the  **Apply the selected covering to the selected object in the drawing** button.  
Or right-click on the covering and select the **Apply to selected** command in the context menu.  
Or apply the covering by double-clicking the left mouse button on the covering.

### *To delete the covering:*

1. Select one or more coverings in the **Coverings Browser** toolbar (**COVERINGBROWSER**).
2. In the toolbar, click the  **Delete selected coverings** button.
3. To delete all unused coverings (except for the Global covering), click the  **Delete created coverings** button in the bar.
4. Coverings applied to the drawing are not deleted from the **Coverings Browser**.

# TOOL PALETTES

-  Ribbon: **Manage – Palettes >  Tool Palettes**
-  Menu: **Tools –  Tool Palettes**
-  Menu: **View – Toolbars – Functional –  Tool Palettes**
-  Toolbar: **Standard – **
-  Command line: **TOOLPALETTES**

Create and save own tools for frequently applied commands, blocks, hatches etc.

*Tool* is a command in the **Tool Palettes Manager**, it can carry property values (color, layer etc.). Tools are located in the tool palettes.

Tool palettes data files location is displayed in the **Standard directories** node of the **Options** window.

Each tool in the **Tool Palettes Manager** has an icon. Drag it to the drawing space or double-click to execute the command (block is inserted, hatch is created etc.). User tools can be exported to .xtp files and then transferred to another computer with import into nanoCAD.

Tool palettes allow the user to collect specialized tools for process design within a single project or within one department without any effort ensures uniform styles.

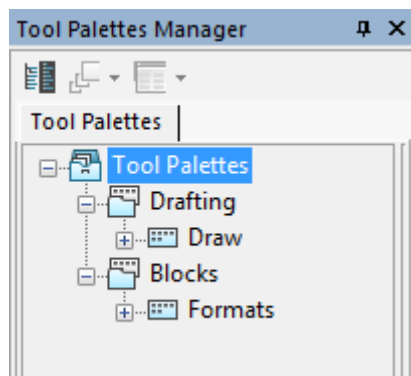

The **Tool Palettes Manager** functional bar displays a tree containing icons of tool palettes and tool palette groups. Root node initially named **Tool Palettes**. It has a context menu with the following items:

**Create group** – creates a new group for storing tool palettes and nested groups;

**Create palette** – creates a new palette for storing tools;

**Rename** – renames the root node;

**Import palette...** – imports a tool palette from .xtp file.

There are three icons with the functions:



**Change icon size**

Configures the icon size (**Small, Normal, Large**).





**Change view style**

Selects an option of standard presentation of lists in the window (**Icons, List, Details**).



**Change active view**

Changes the active view option (tree or list).

The  button switches between two active view modes: tree or list. The  and  buttons are disabled in the tree mode. Dialog has a splitter (vertical dividing line) placed on the right in

the tree mode and on the left in the list mode. Move the splitter to enter the view mode with display both tree and list.

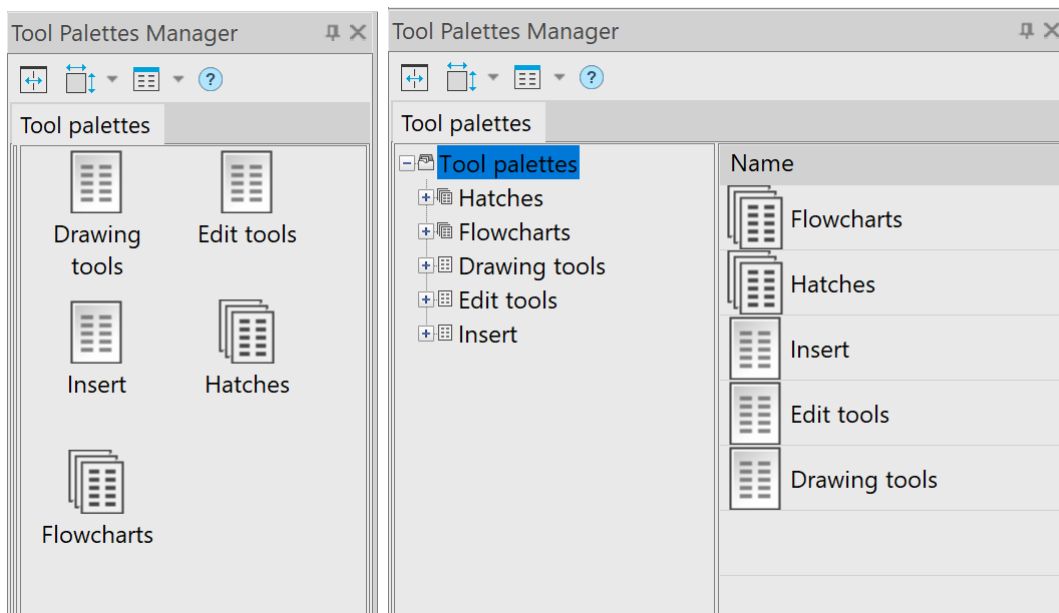

## Create a Tool Palette

*Tool palette* is a container for tools joined by user. A new empty palette can be created with the **Create palette** item of the context menu. You can drag palettes to move them inside the group. The **Tool palettes** bar can contain any number of tool sets with any names.

The tool palette node  has a context menu with the following items:

- **Customize commands...** – opens the **Tool Palette Customize Manager** dialog with nanoCAD commands list;

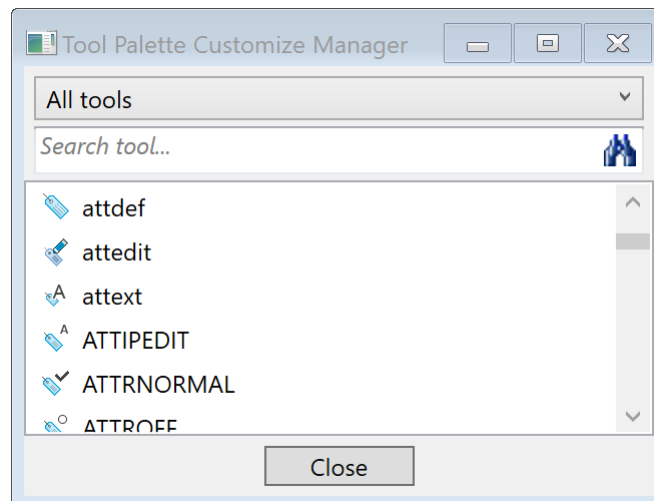

- **Rename** – renames tool palette;
- **Sort by** – sorts by feature (**Name, Type**);
- **Move up** – moves palette one position up;
- **Move down** – moves palette one position down;
- **Remove** – removes selected palette from the **Tool Palettes Manager** functional bar or from the group.
- **Export** – exports tool palette to .xtp file.

## Create a Tool Palette Group

In the **ToolPalette** tree, you can create *groups*, which are similar to folders and can contain tool palettes and nested groups. To create a group that should be a child of the root node of the tree, you should use the **Create group** item in the context menu of the root node. To create a group that is a child of another group, use the same name context menu item of the parent group icon.

A palette is added to a group by dragging the palette icon from the root node or from another group. A palette is moved from a group to the root by dragging the palette icon onto the root node.

When working with tools, palettes, and groups simultaneously, it is recommended to use both tree and list views. Then, in the right part of the window, you will see the child elements for the node that is selected in the tree on the left side. Double-clicking the icon on the right side of the **Tool Palette** bar displays the contents of the corresponding folder or tool palette.

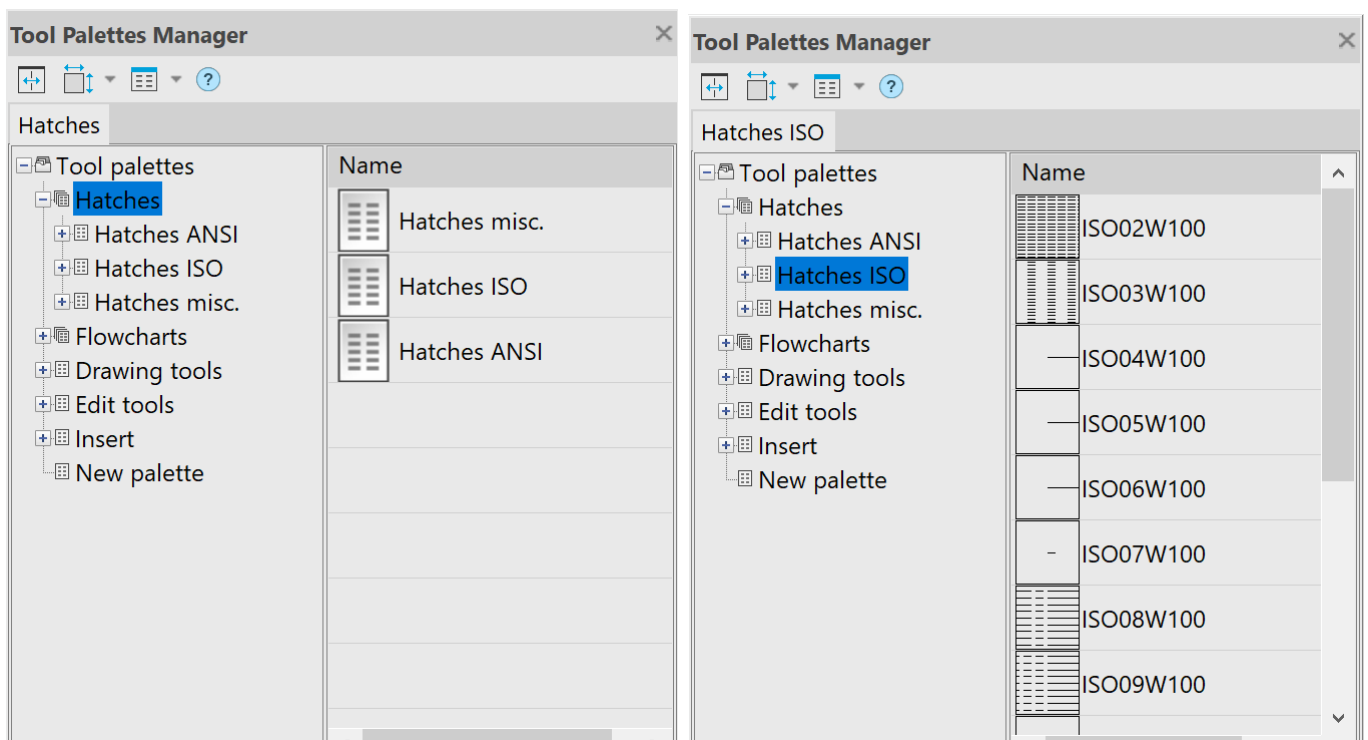

The group node  has a context menu with the following items:

- **Create group** – creates subgroup;
- **Rename** – renames group;
- **Move up** – moves group position up;
- **Move down** – moves group position down;
- **Remove** – removes selected group.

## Create a Tool

To create a new tool in the **Tool Palettes Manager**, select an object of the required type in the drawing or in the file explorer and by drag&drop method drag it to the tool palette icon . As a result of this operation, a tool icon will appear in the tool palette with some initial property values (copied from the parent object).

One more method to create a tool is to drag the command from the **Tool Palettes Customize Manager** window (the window opens by **Customize commands...** item of the context menu of

the tool palette being edited) to the palette icon in the tree of the **Tool Palettes Manager** or to the window of earlier created tools of the palette.

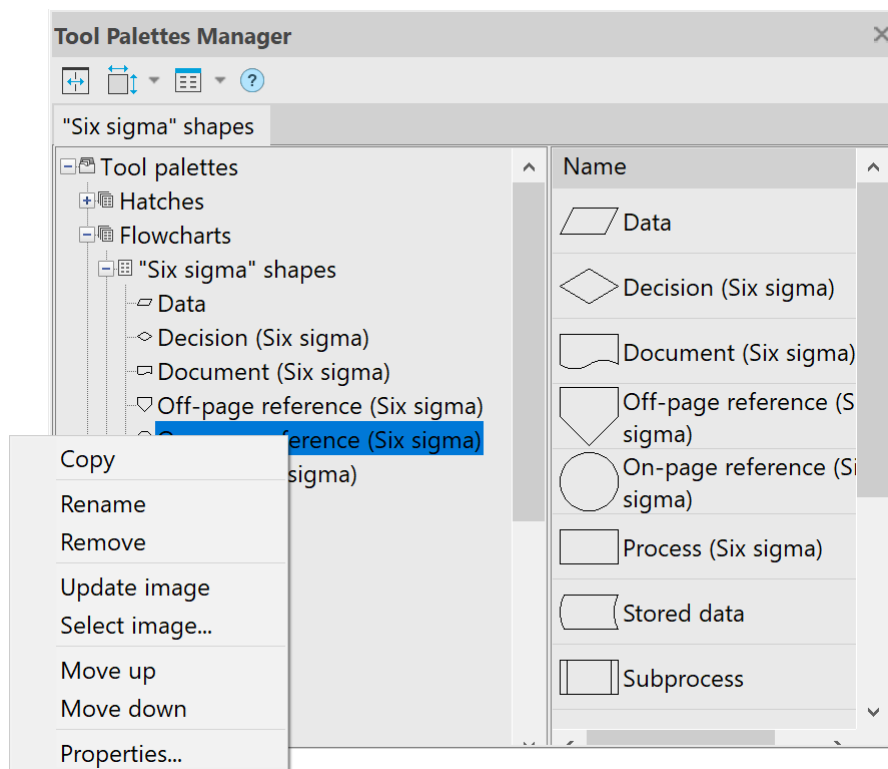

**Tool** has the following context menu:

- **Copy** – copies tool to the clipboard;
- **Rename** – renames tool;
- **Remove** – deletes tool;
- **Select image...** – opens **Open** dialog to select image for tool icon(extensions .jpg, .jpeg, .tiff, .tif, .bmp, .png are allowed);
- **Move up** — moves tool one position up;
- **Move down** — moves tool one position down;
- **Properties...** – opens the**Tool Properties** dialog box.

The **Properties...** item opens the **Tool Properties** dialog box with the current settings of the tool and the properties of the objects it creates.

For most objects, the properties window looks like this:

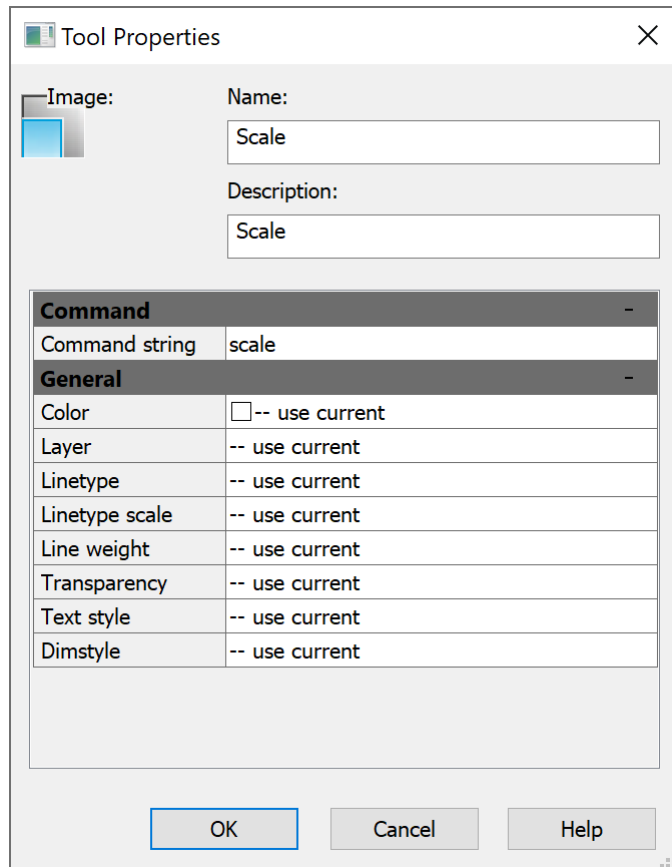

Set necessary properties of selected tool in the **General** section. Type necessary command options in the **Command string** field. Call **Select image...** context menu to change the icon for a tool. Tool properties dialog looks different for block:

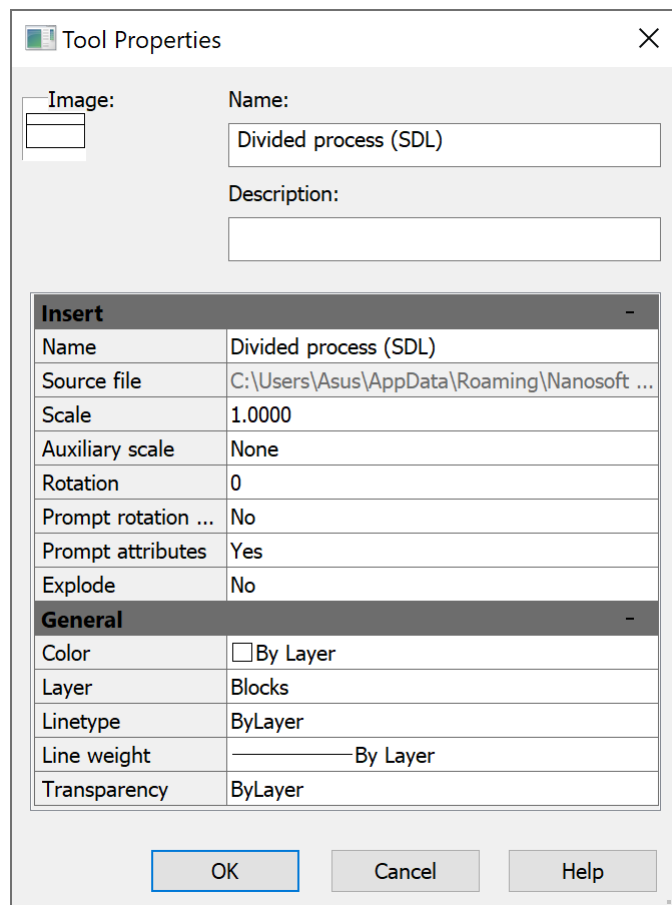



This tool creates a block insertion in the drawing. The **General** section contains general properties (color, layer, linetype, linewidth and transparency).

**Insert** section contains specific parameters of the block insertion:

- **Name** – block name;
- **Source file** – path and name of the file with block definition;
- **Scale** – value of insertion scale;
- **Auxiliary scale** – auxiliary scale factor for block insertion:
  - **Dimscale** – the DIMSCALE system variable value used as an auxiliary scale factor;
  - **Plot scale** – auxiliary scale factor is taken from the plot scale assigned to the current layout of the drawing;
  - **None** – no auxiliary scale factor is used;
- **Rotation** – rotation angle of the block, used when the **Prompt rotation angle** is off;
- **Prompt rotation angle** – turn on/off prompt of rotation angle when block inserted;
- **Explode** –exploding flag for block insertion (**No** or **Yes**).

The hatch tool properties dialog box contains options that are specific to hatching:

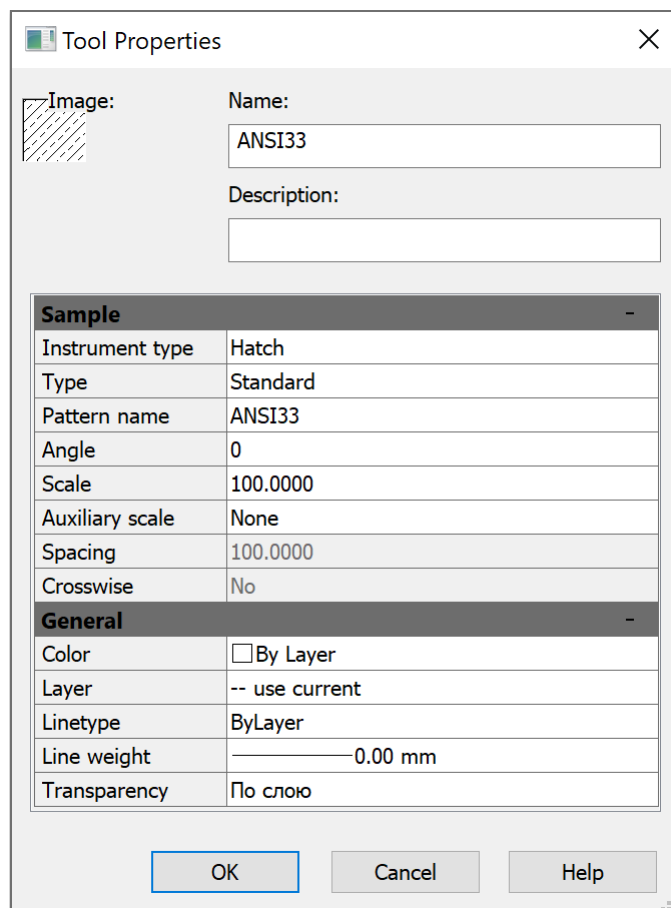

## Execute the Tool

Use double-click on the tool or drag it into the drawing space. This action calls nanoCAD command with specified properties (color, layer, linetype, etc.). If the command has several work options then only the most popular one is chosen. For example, Circle tool calls circle by center and radius.

The block tool also can be executed by double-click or by drag. If auxiliary scale is set in the block tool properties then the final scale for block insertion will be calculated as multiplication of the main and auxiliary scales. If **Prompt rotation angle** is set to **Yes** then rotation angle will not be taken from the **Rotation** parameter and will be requested in command line.

## Delete the Tool

Use **Remove** item from the tool context menu.

## Edit the Tool

Use **Properties...** item of the tool context menu to edit parameters of tool.

## Export Tool Palette

It is possible to transfer tool palette to another computer. Use Export item of context menu, palette is imported to .xtp file (for further import on a target computer).

This method provides distribution of tools with similar layers, styles settings and other properties to any number of computers engaged in the same project and using nanoCAD.

## Import Tool Palette

It is possible to import tool palettes from .xtp files created in nanoCAD or AutoCAD. Use the **Import palette** item of the context menu in the **Tool Palettes Manager**.

The current version of nanoCAD does not support AutoCAD multicommand tools (a group of commands can be united under one icon with pop-up menu). nanoCAD displays the following message:

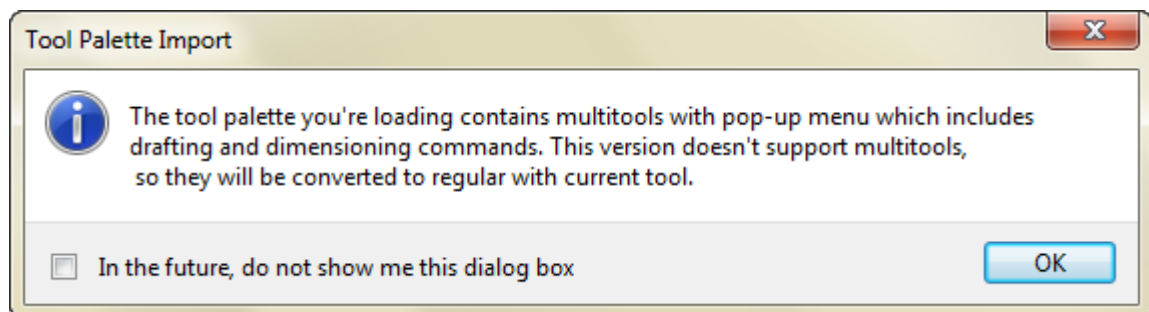

In this case only the last used command of tool is imported instead of the commands group. Command line shows the following messages:

```
Multitool "Circle by Center and Radius" has been converted to regular.
Multitool "PolyLine" has been converted to regular.
Multitool "Spline" has been converted to regular.
```

Some tools are unsupported:

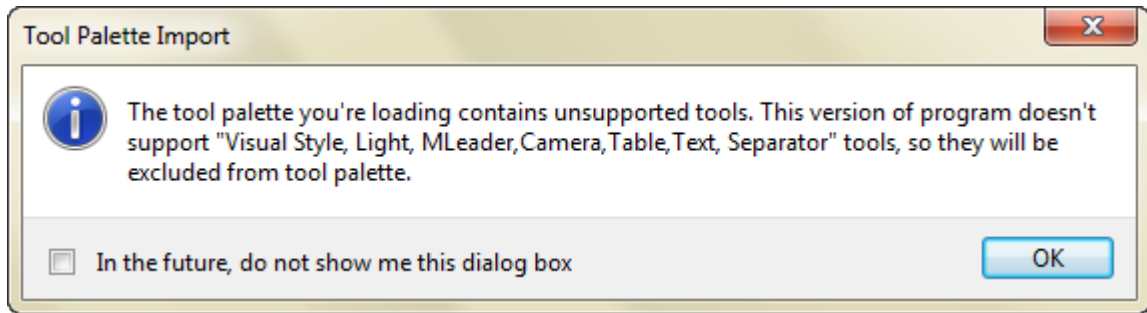

In this case only supported tools are imported. Command line shows the following messages:

```
Skipped unsupported tool: Light  
Skipped unsupported tool: Separator  
Skipped unsupported tool: Camera
```

# POINT CLOUDS

A point cloud is a large set of points in a three-dimensional coordinate system. In most cases, a point cloud is the result of a 3D scanner proceeding. This device allows you to get an idea of the surface geometry of the scanned object.

**NOTE:** The **Point** object and the cloud point are different entities in the program.

In addition to coordinates, a point can contain additional information - metadata (attributes). Some metadata is the result of the scanning process (intensity, color, time, etc.), and some is added to the point when working with the cloud (class, normal, etc.).

Point cloud is a separate object, some of its properties can be viewed and edited in the **Properties** bar. In addition to specialized operations, standard editing commands are available for point clouds, such as move, rotate, scale, mirror, align.

Moving, rotating, scaling, flipping, aligning will be blocked if the **Transformation status** option is disabled.

Misc	
Name	Point cloud
Path	C:\Users\Asus\AppData\Roaming\...
Mode	Loaded
Point cloud info	
Transformation status	Enabled
<b>Geoinfo</b>	<b>Enabled</b>
WKT String	Disabled

You can also set the point cloud loading mode in the **Properties** bar.

Misc	
Name	Point cloud
Path	C:\Users\Asus\AppData\Roaming\...
Mode	Loaded
Point cloud info	Not found
Transformation status	Unloaded
<b>Geoinfo</b>	<b>Loaded</b>
WKT String	Frozen
Reference Surface	

For multi-user network access, it is possible to load a point cloud from an NPC file located on a network resource. When importing a network NPC file, the point cloud data are frozen and the absolute path to the NPC file is set. Any attempts to modify the data of the cloud itself (NPC file) become unavailable, and a link is established to the NPC file that was imported. Together, this allows multiple users to work on a single NPC file. At that, all commands to modify the cloud are fully applicable to such a cloud. A similar possibility to switch the cloud to this mode is provided by changing the **Mode** property of the **Properties** bar to the **Frozen** position. In this mode, the cloud (NPC file) is not re-saved!

## Import of Point Clouds



Ribbon: **Point Clouds > Point Cloud >**  **Import**



Menu: **Insert >**  **Point cloud**

 Menu: **Point clouds** >  **Import**

 Toolbar: **Point cloud** > 

 Command line: **NPC\_IMPORT**

Inserts point clouds to the current drawing from LAS, LAZ, BIN, PTX, PTS, PCD, TXT, XYZ, XYB, PLY, E57, RCS, RCP, NPC files. File formats are described in more detail in the Point Cloud Data Formats section.

## Import from Text Formats

When importing point clouds from text files (TXT, XYZ, XYB), a separate **import wizard dialog** is displayed. It allows you to set the data interpretation rules for the imported file.

Import
— □ ×

**▼ File**

**▼ Special**

New line char     Content Start Line     Comment

**▼ Separator**

. dot   
 , comma   
 \t tabulation   
 ; semicolon   
 space



Other   
   
Decimal separator

**▼ Data**

1	515966.925	4776857.852	-6.729	2	2	2	2	2	2
2	515953.324	4776792.705	20.981	3	3	3	3	3	3
3	515968.340	4776716.455	47.044	4	4	4	4	4	4
4	515916.144	4776883.108	-12.578	5	5	5	5	5	5
5	515917.966	4776767.925	18.347	6	6	6	6	6	6
6	515872.299	4776854.047	-8.046	7	7	7	7	7	7
7	515869.741	4776798.063	-5.317	8	8	8	8	8	8
8	515876.091	4776744.099	12.892	9	9	9	9	9	9
9	515817.239	4776878.725	-30.847	10	10	10	10	10	10
10	515814.599	4776835.826	-24.799	11	11	11	11	11	11
11	515818.832	4776805.915	-24.687	12	12	12	12	12	12

**▼ Result**

	<input checked="" type="checkbox"/>	X	<input checked="" type="checkbox"/>	Y	<input checked="" type="checkbox"/>	Z	<input type="checkbox"/>	I	<input type="checkbox"/>	R	<input type="checkbox"/>	G	<input type="checkbox"/>	B
14		14516007.6734776452.76865.596151515151515												
15		15515962.7004776652.24570.63116161616161616												
16		16515946.9114776600.70188.307171717171717												
17		17515952.2094776552.62492.377181818181818												
18		18515951.9354776487.37582.774191919191919												
19		19515916.0664776636.11966.628202020202020												

Current profile:   

### Options:

#### Special

Specifies the next line character, the line from which data starts and the characters that are interpreted as the start of a line with comments.

#### Separator

Specifies character that separates text file data. You can choose both predefined character (semicolon, tab character, comma, space), and set any other one.

**Consider consequent separators one**

Specify a character used to separate whole and fractional parts of values

*Data*

Preview of text file data.

*Result*

Specify correspondence of text file columns to certain data types: point coordinates by X, by Y and by Z, intensity value, point color in RGB (red, green, blue).

The **Data** field displays 100 lines from the file, and the **Result** field displays 50.

Changing the **Content Start Line** value will display the next 50 lines.

After **Text Files Import Wizard** is closed, the main point clouds Import dialog box opens.

## Point Clouds Import Dialog Box

The **Import** dialog box allows you to specify what data to import and how. It gives visual representation of the file's point cloud and get understanding of the data in the file.

The dialog that opens shows base parameters and visual representation of point clouds in imported file.

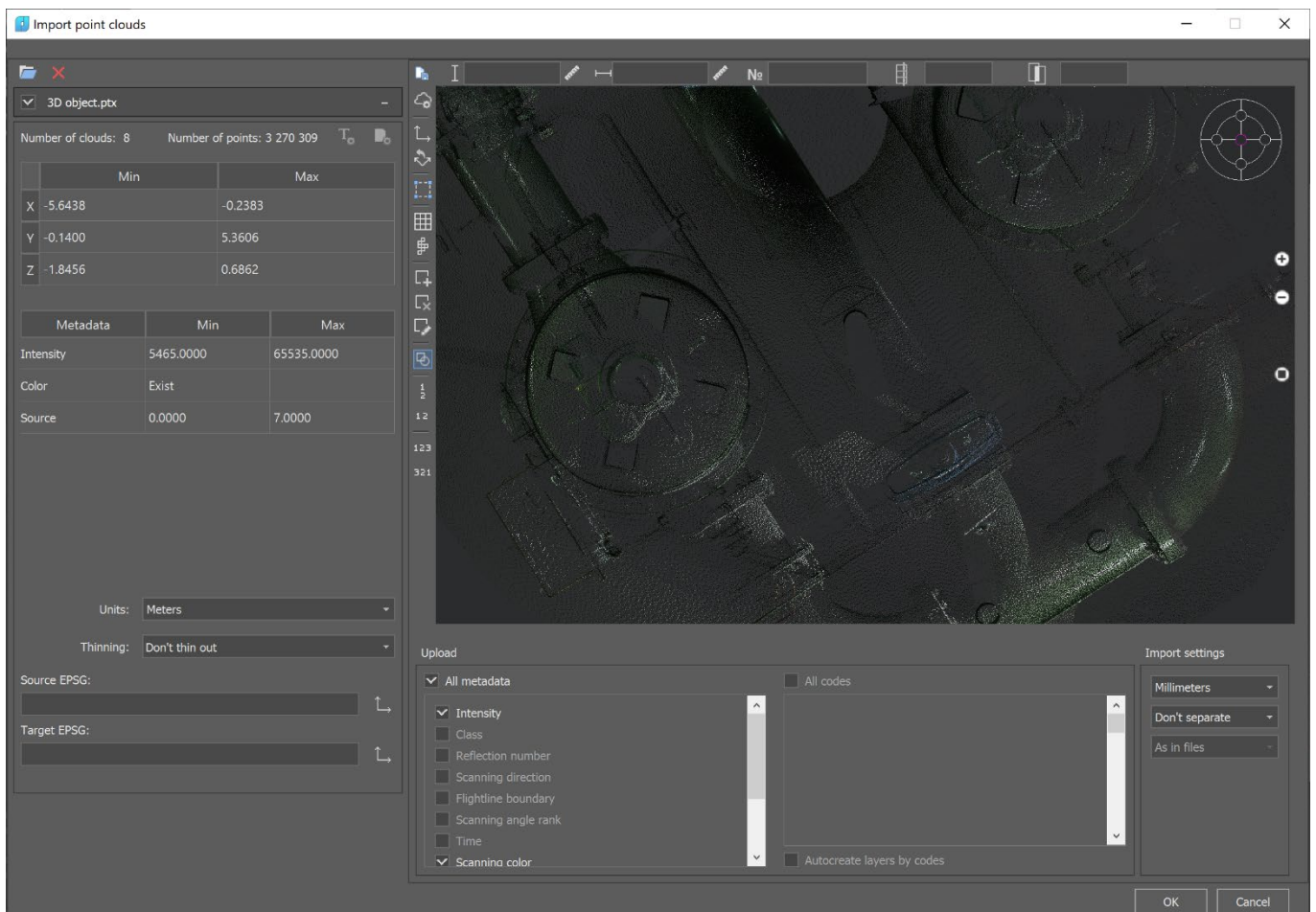

The import dialog allows you to:

- import several files at the same time;
- view detailed information about each file and its metadata values;
- set an individual point cloud transformation from each file using EPSG codes (if the point cloud has a coordinate system described by the EPSG code, or the user sets EPSG for it manually);
- organize a preview of a point cloud in 3D, as well as to select a spatial fragment in any perspective selected by the user;
- set units of measurement for source data, as well as manage drawing units and data conversion from source units to drawing units;
- specify the types of metadata to be imported from source data;
- specify the classes to be imported from the source data;
- set data thinning during import;
- set partition into clouds by classes, sources, echoes;
- split point clouds into blocks, both along the grid and along the flight line. In this case, the cloud is not loaded immediately into the drawing. A set of dwg files is created in the folder with the point cloud, each of which contains a block - a fragment of the cloud, obtained by splitting the source file in accordance with the specified parameters. The function is convenient to use to automate import, the resulting fragments can be loaded into the drawing separately, significantly reducing the amount of memory used;
- remove files from the downloaded list.

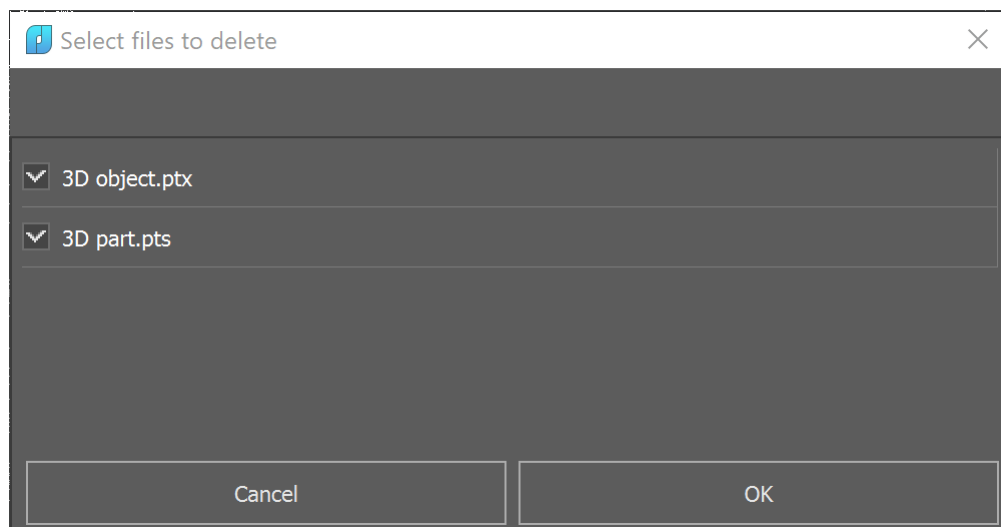

### **Options:**

#### *Selected file*

Displays the path to imported file.

#### *Preview*

Preview displays all contents of the imported file. You can specify areas to import. By default, all points will be imported, However it is possible to specify one or more areas of diverse geometry instead of loading all file points. To select areas, you must activate the set of area selection tools:

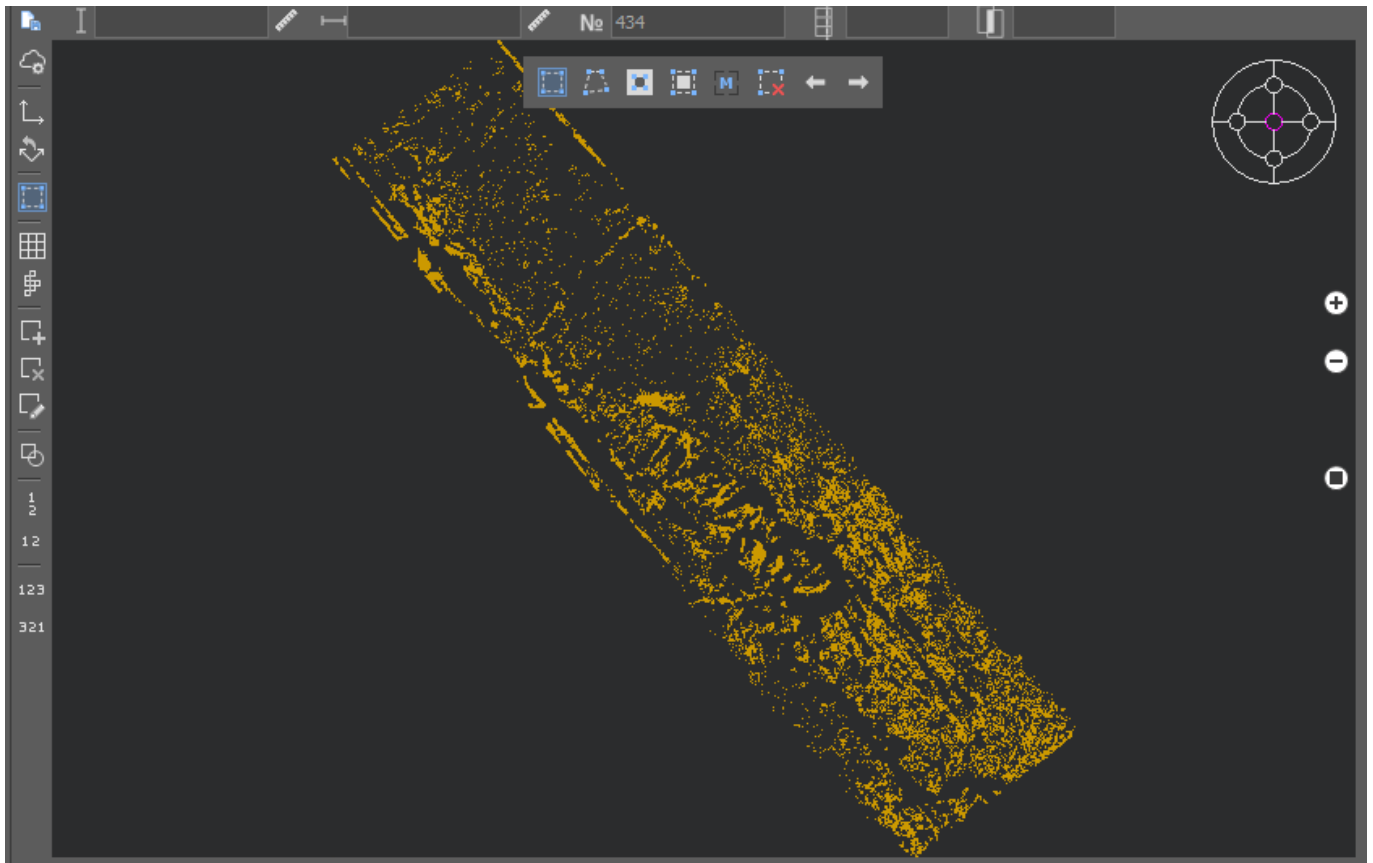

**Rectangle selection**

Specifies a rectangular area whose points will be imported into the document. Several such areas may be defined.



**Polygon selection**

Specifies the polygon area whose points will be imported into the document. To stop specifying the area, right-click the mouse. Several such areas may be defined.



**Invert selected**

The tool allows you to invert the selected areas.



**Select all**

Select the entire contents of the file being imported.





**Select by coordinates**

Manually specifying the coordinates of the area whose points will be imported into the document. The button opens a dialog box, in the fields of which the coordinates of the full scan boundaries are indicated. To create an area in this case, the coordinates of the desired area are indicated in the fields.

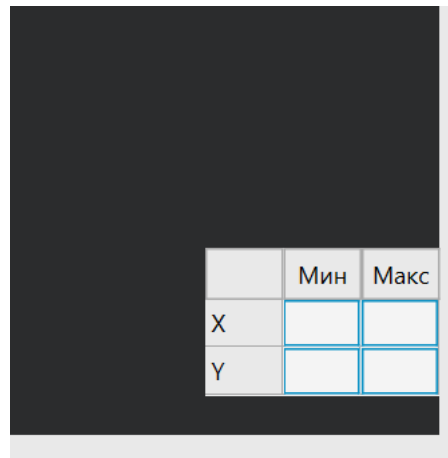

Several such areas may be defined.

Allows you to completely remove all previously selected areas.



**Reset selection**



UNDO, REDO selection

It is possible to undo and redo operations for creating selection areas.

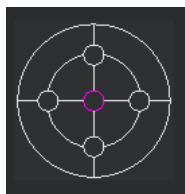

View locator, similar to that in the main window. Allows you to select standard views.



Enlarges, reduces, or displays the entire image in the preview window.



**Show all files**

Upon clamping, it turns on the mode of displaying the data of all files in the preview window. When unclamped, the mode of displaying only the data of the currently selected file works.



**On/Off project mode**

When unclamped, it activates the mode of importing into the current document. When clamped, it activates the project work mode. In this mode it is possible to split the resulting data set into blocks, create a project file, as well as a project mosaic drawing.



### **Edit project information**

Clicking this button opens the project description editing window. Only available in the project creation mode 

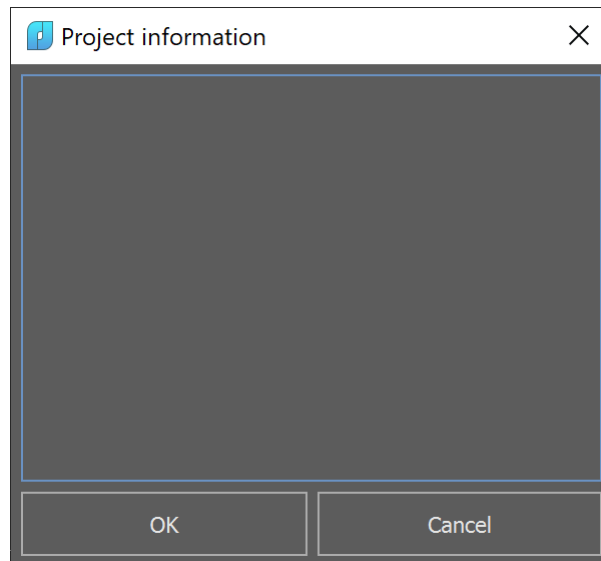

### **Show axis**

When clicked, activates the display of the project CS axes. Only available in the project creation mode 



### **Rotate axis**

Tool for setting a project coordinate system. Only available in the project creation mode 



**On/Off grid of blocks**

Only available in the project creation mode

Specifies the size of blocks and their numbering mode (to automatically generate a number, you need to use round brackets in which to place the starting number), number of blocks perpendicular to line and overlap width of blocks:



It is possible to measure distances in the preview window

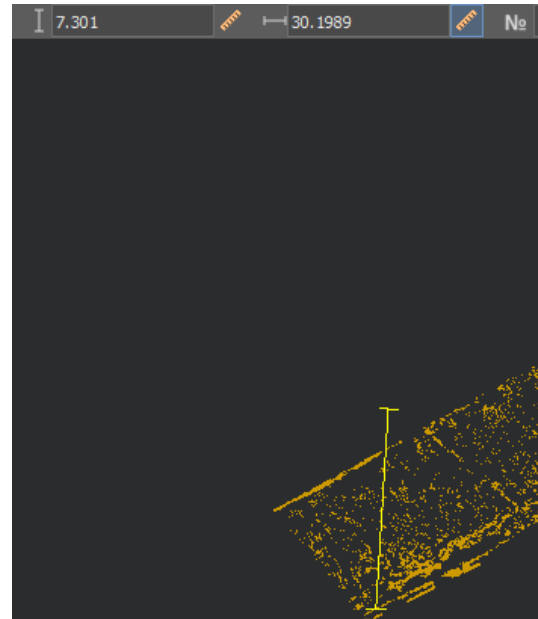



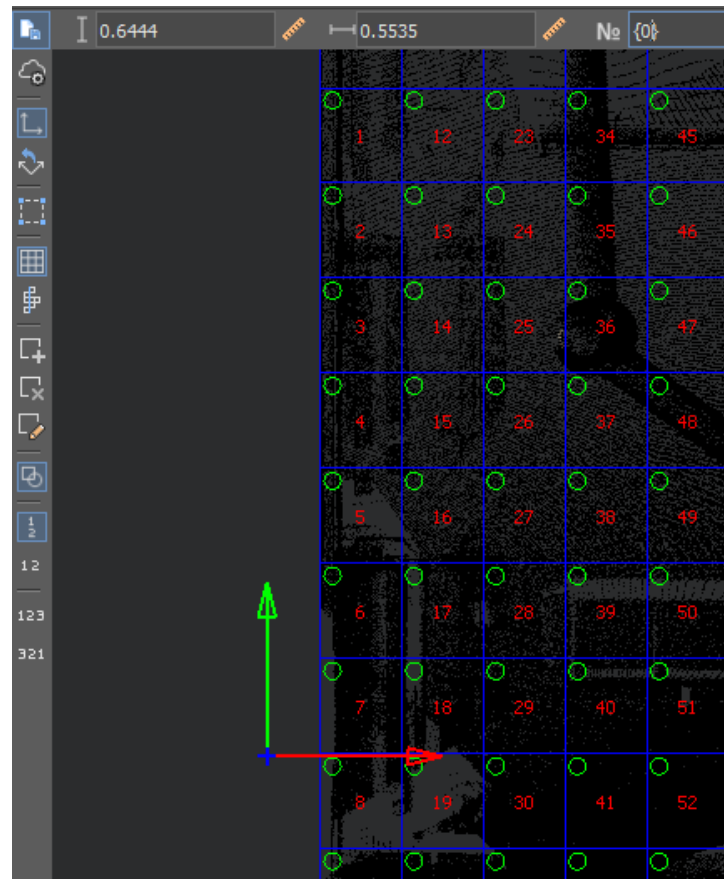

The result of this mode is the creation of a split grid





**On/Off blocks by flight line**

Only available in the project creation mode 

Specifies the size of blocks and their numbering mode  (to automatically generate a number, you need to use round brackets in which to place the starting number),  number of blocks perpendicular to line and  overlap width of blocks:



It is possible to measure distances in the preview window

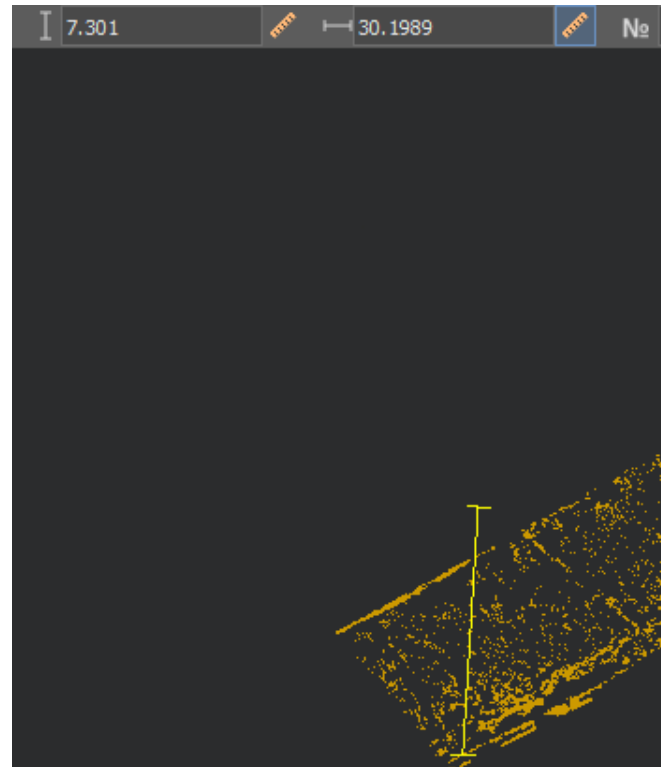

Next comes the flight line selection

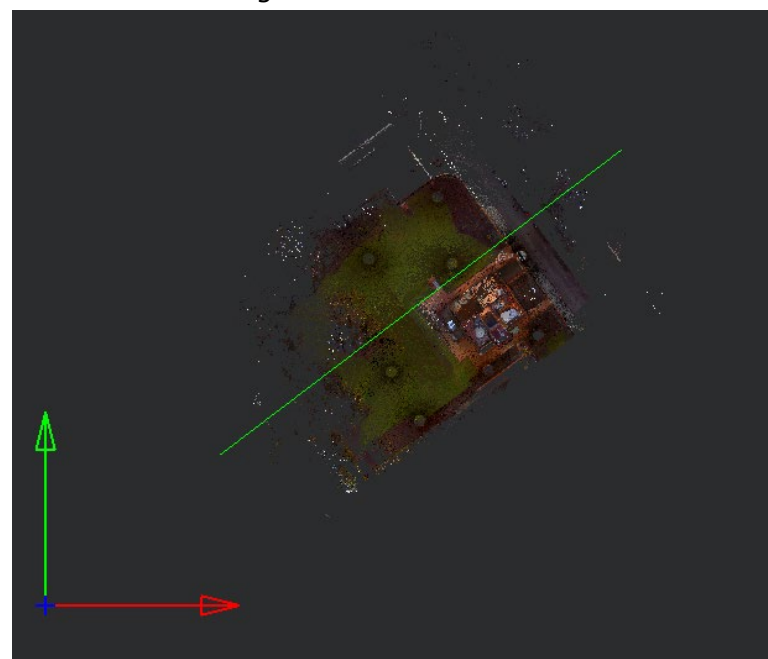

**Add block**

Only available in the project creation mode 

Works only in flightline splitting mode.

Allows you to create a new block where the user specifies.



### Remove block

Only available in the project creation mode   
 Works only in flightline splitting mode.  
 Allows you to delete an existing block.



### Edit block

Only available in the project creation mode   
 Works in both splitting modes (grid and flightline).  
 Allows you to change the block name manually.



### Show all files

**On** – Shows all files.  
**Off** – Shows only the last one



### Switching block numbering

Enables vertical numbering;  
 Enables horizontal numbering;  
 Enables start to end numbering;  
 Enables end to start numbering.

#### *File Information*

This section displays statistics on the points of the imported file. You can set the units of the cloud, its coordinate system, and adjust thinning.

It is possible to reduce the density of imported clouds, in case of its redundancy, by importing every second/third/tenth, etc. file points. To do this, check the **Interval** box and specify the sequence number of the imported point in the **Import each <...>** field.

Using the checkbox in the left corner of the panel, you can include this file in the import data set or exclude it. For text files, there is a format setting button in the upper right corner (a description of the text file import settings window can be found in the Text File Import Wizard).

Survey.las

Number of clouds: 1      Number of points: 6 609 829

	Min	Max
X	256000.0000	256999.9900
Y	4111000.0000	4111999.9900
Z	384.6600	510.2500

Metadata	Min	Max
Intensity	0	0
Class	2	2
Reflection number	0	0
Scanning direction	0	0
Boundary of flight line	0	0
Scan Angle Rank	0	0
Time	0	0

Units: Meters

Thinning: Don't thin out

Source EPSG:

Target EPSG:

*Detailed file information*

Further in the right corner there is a button for obtaining detailed information about a LAS or LAZ file, you can view the properties in a text dialog.

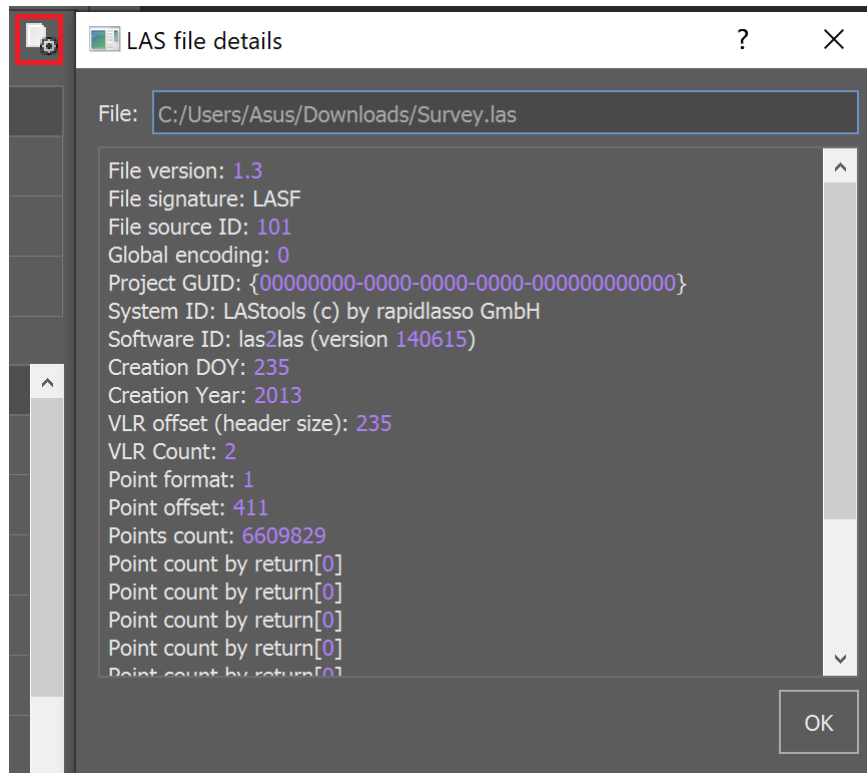

*Convert to*

Setting up coordinate systems works as follows. If the file does not have a georeference, then it can be selected manually.

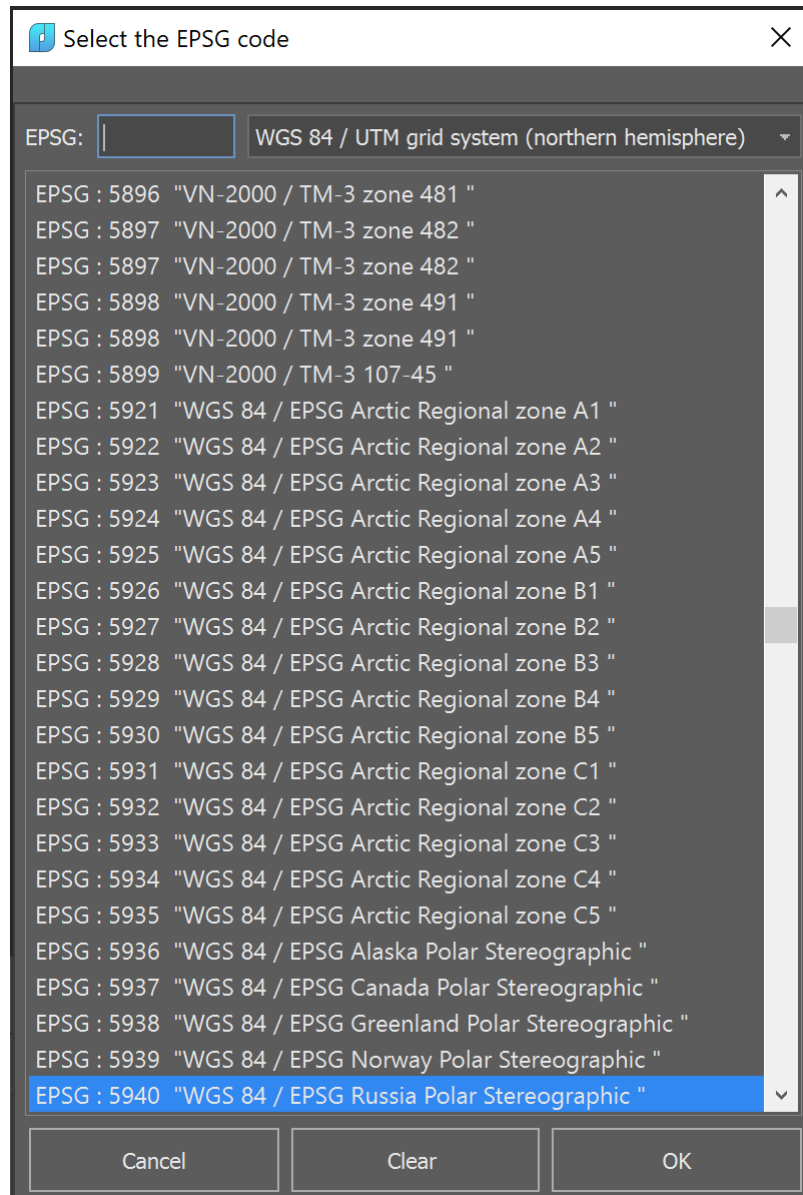

Having selected the desired coordinate system, we proceed to specify the target coordinate system in the same way.

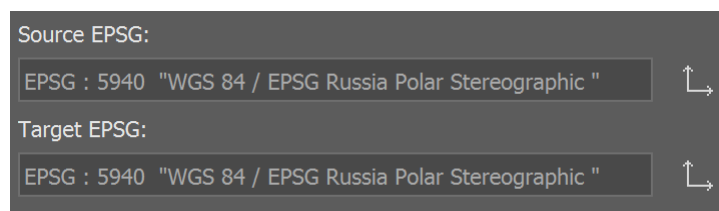

If the file has a georeference written to the file itself, then you do not need to select the source coordinate system, it will be automatically filled in when opening the file.

When importing multiple files, the target coordinate system cannot be set differently for different files. Changing the target coordinate system for at least one file will automatically change it for all.

Besides, if there are several source files and they have different source coordinate systems, when you click OK, a message appears asking for the same source coordinate systems or to set them to a target coordinate system.

*Filter by metadata*

This list contains all metadata (attributes) of points present in the file.



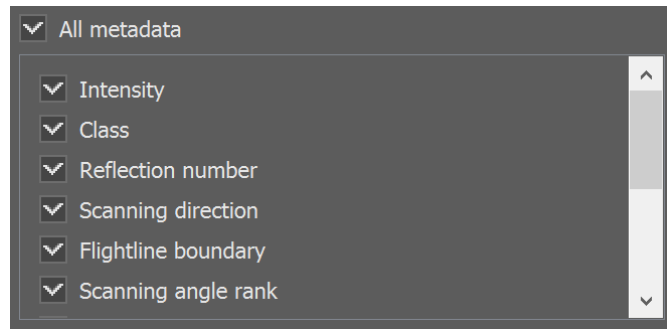

After import, the points will have only the attributes selected in this list. Unselected attributes will not be included in the document.

### *Filter by code*

This list contains all the classes to which the points of the imported file have been distributed. If the cloud points had no classes, the list will be empty.

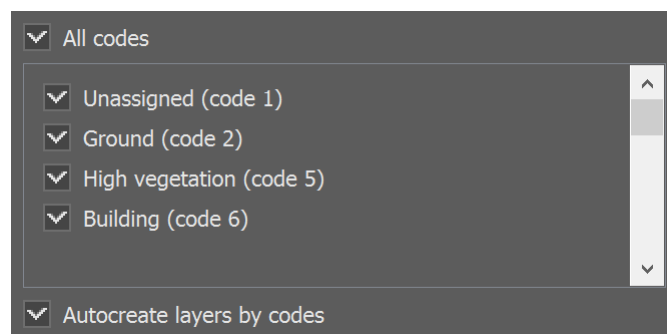

Only those points that belong to the classes selected in this list will be imported. Points of the classes that were not selected will not be included in the document.

### *Auto fill code layers*

Creates layers with names of classes. Layers named according to LAS standard classification. Each layer get the **FC#N** description, where: **FC#** - index number, **N** – class number.

If the **Auto fill code layers** checkbox is off, then a single layer **Point Cloud** will be created during the import. The description field of this layer could be filled manually.

### *Differentiation*

By default, file points are imported into the document as a single cloud. However, it is possible to import points as multiple clouds. The division of points into clouds can be carried out according to various criteria.

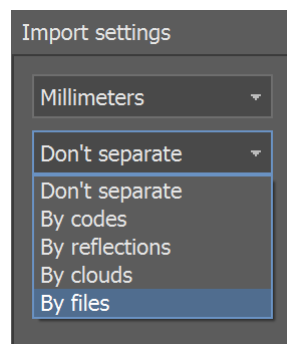

#### **Don't separate**

Import one cloud regardless of the cloud number in imported file.

#### **By codes**

Import points as separate clouds. Each cloud contains points with its code and one cloud with unclassified points.

- By reflections**                      Each cloud contains points with its value reflection.
- By clouds**                              Divide points on the number of clouds in file.
- By files**                                In the By files separation mode, cloud objects (both entire clouds and their parts located in external constraints) have the same names as the files from which they were loaded.

**NOTE:** Special option hides separate points to avoid nanoCAD braking. This option is enabled by default. Turn on **Display all points** in **Point clouds – Settings** menu to display all points of cloud. It is also not recommended to open files from the Desktop in Windows. Point clouds with more than 2.4 billion points are not supported. To be able to work with the data, you should split the point cloud into smaller parts using our import tools.

## Export of Point Clouds

 Ribbon: **Point Clouds > Point Cloud >**  **Export**

 Menu: **Point Clouds >**  **Export**

 Command line: **NPC\_EXPORT**

This command exports point cloud to different formats: LAS (1.2 and 1.4 versions), BIN, PTS, XYZ, PLY, E57, RCS. File formats are described in more detail in the [Point Cloud Data Formats](#) section.

- The following dialog appears if point cloud has meta data. Select attributes to export in a file. If all checkboxes are turned off, then only point coordinates are exported without attributes.

Export point clouds

<input checked="" type="checkbox"/> code	<input type="checkbox"/> time
<input checked="" type="checkbox"/> intensity	<input type="checkbox"/> scan color
<input type="checkbox"/> return number	<input checked="" type="checkbox"/> source ID
<input checked="" type="checkbox"/> scan direction	<input type="checkbox"/> normal
<input checked="" type="checkbox"/> scan angle rank	<input type="checkbox"/> deviation
<input checked="" type="checkbox"/> edge of flight line	
<input type="checkbox"/> geo reference	

- Then specify file format, file name and path.

**NOTE:** Extension of XYZ file depends on selected attributes: **\*.xyziedlastrgb** , - for all selected attributes, **\*.xyz**. – without selected attributes.

If the cloud was clipped with one of [clip](#) or [section](#) commands, then only visible points are exported.

**NOTE:** Since a clip (or a section) creates for a certain view, then it is very important what model space view is current at the moment of the **Export** command launching.

If the point cloud has the **Class** attribute, then only points from visible, unfrozen, unblocked layers will be exported.

**Command prompt:**

Use all clouds in view? <No>  
or [Yes/No]:

This prompt is displayed when there are more than one point cloud in the viewport.

**Command options:**

- Yes Exports all visible points of all clouds from the viewport. All points, which are invisible in active viewport, because they are outside viewport margins, will be also exported.
- No Displays the following prompt:  
Select point clouds or [?]:  
Specify the cloud to be exported, or select ? option.
- ? Shows the following prompt in the command line:  
Select an option or  
[Window/Last/Crossing/Box/ALL/Fence/WPolygon/CPolygon/Group/Add/Remove/Previous/Auto]:  
Select the cloud with one of the options. (see [Selection of Objects Using the Command Line](#) section)

## Work with DBMS-Based Point Cloud Storage





Developed as part of support for work with point clouds, the point cloud storage architecture allows it to be used for implementation over various data storage technologies. In the base part of nanoCAD, it is used over the memory of the process of nanoCAD application. This approach limits the amount of data that can be used when working with nanoCAD. To remove the limitation on working with super-large point clouds, a storage implementation variant with the architecture described above was developed on the PostgreSQL DBMS. The features described below are the first step taken to support storage of extra-large point cloud data using this technology. At this stage, the infrastructure was created for exporting point clouds uploaded to nanoCAD to a new storage, importing data from this storage back, as well as storage administration utilities based on the PostgreSQL DBMS. It is assumed that the import of super-large clouds will be carried out on a computer with high performance characteristics and a large amount of RAM. The storage itself will be deployed in the user's local network on the PostgreSQL DBMS. Under such conditions, all computers located in the same local network with nanoCAD installed on them (provided that they get access to the deployed storage) will be able to work with parts of the cloud uploaded to the storage, having a much smaller amount of RAM and lower performance characteristics. This will be achieved due to the fact that when importing a part of the cloud from storage, only the data that make up the selected fragment will be transferred to the local computer.

In addition, the principles of versioning of saving point clouds are incorporated into the storage design. This allows you to incrementally update the data in the storage when processing the point clouds stored in it.

One database with storage can store an unlimited number of point clouds and their versions (limitations are placed only by the DBMS capabilities and server characteristics).

The development of this technology in the future will allow in the next versions of nanoCAD to implement the direct operation of the Point Cloud object on the storage over the PostgreSQL.

## Importing Cloud Data from DBMS

-  Ribbon: **Point Clouds > Point Cloud >**  **Importing Cloud Data from a Database**
-  Menu: **Point clouds > Database >**  **Importing Cloud Data from a Database**
-  Toolbar: **Point clouds >** 
-  Command line: **DB\_TO\_NPC**

The command allows you to create a point cloud in a drawing using a previously created storage based on the PostgreSQL DBMS as a data source. In this case, it is possible both to import of the full cloud stored in the Database and to select its fragment. Connection parameters for the command can be pre-configured using the connection bar, NPC\_DB\_CONFIG command, or requested directly in the command itself (in this case, the connection used will be saved in the connection bar automatically).

The command parameters allow you to select two modes (working with a previously saved connection is illustrated):

- Full import of a point cloud located in the storage
- Import of a point cloud fragment located in the storage

### Full import of the point cloud located in the storage

Parameters	
Connection name	ReCStream_1 local
Select option	Cottage_1209.npc, 4
Save connection with data	No
Use import dialog	No

To select the full import mode, set the **Use import dialog** property to No. At the same time, accepting the parameters will cause the import process to immediately start, the progress will be displayed by a progress indicator in the status bar of the nanoCAD window. Upon completion, a point cloud will be created in the document, colored by default, containing a link to the DBMS from which it was imported (if the **Save connection with data** parameter is set to Yes). This information is enough for the command of unload to the DBMS (NPC\_TO\_DB) when launched on this cloud, not to export it to the same storage in its entirety, but to update its version and save the metadata changed in the process of working with the cloud.

### Importing a fragment of a point cloud located in storage

Parameters	
Connection name	ReCStream_1 local
Select option	Cottage_1209.npc, 4
Save connection with data	No
Use import dialog	Yes



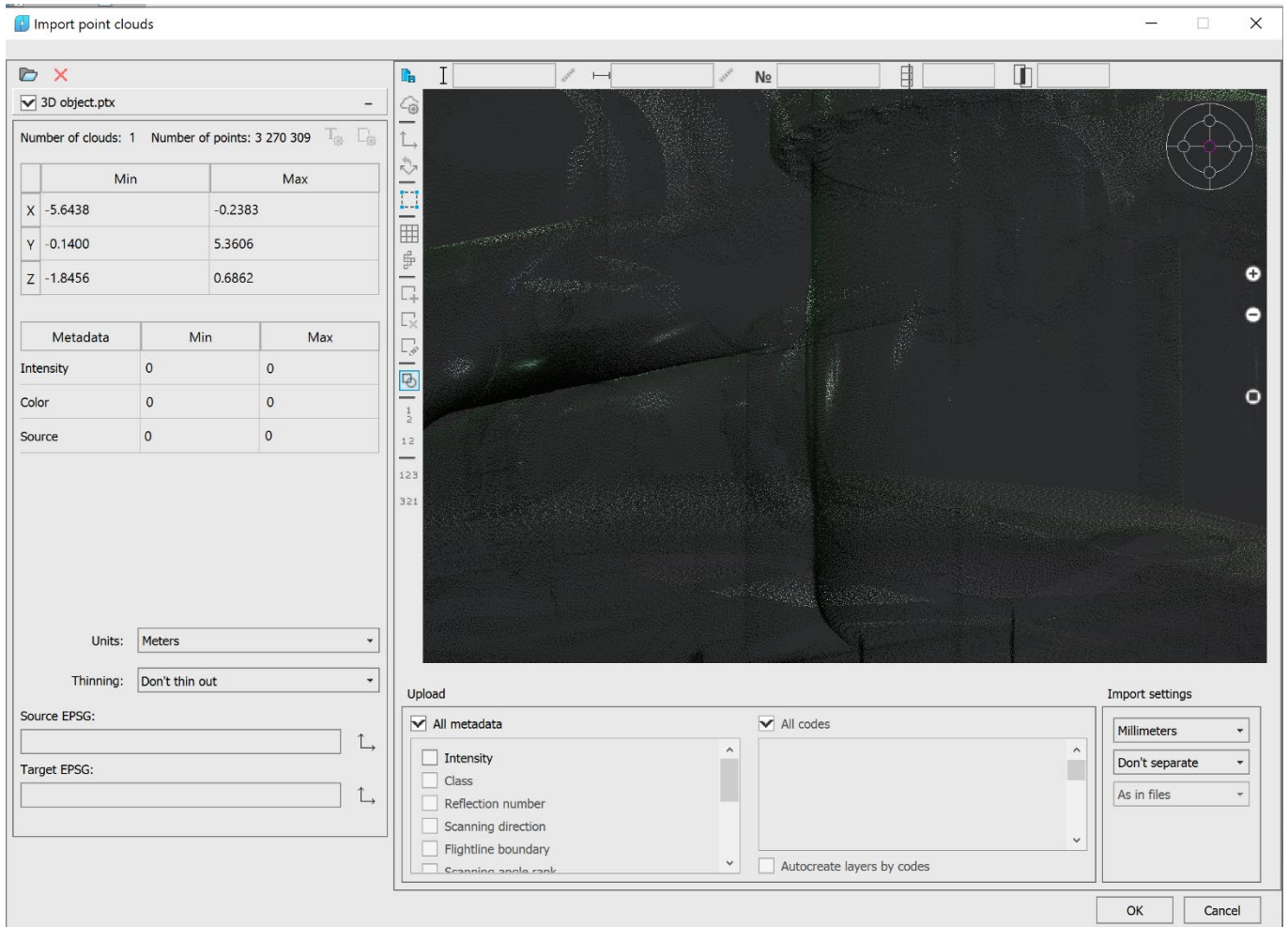



To select the fragment import mode, set the **Use import dialog** property to Yes. In this case, accepting the parameters will launch the import dialog, which will allow you to select the desired area of a point cloud, as well as the required import settings.



After selecting the required area and setting the necessary parameters, you can start the import with the **OK** button. When a fragment is imported, a link to the point cloud storage is not created, and the state of the storage in the DBMS cannot be updated with the state of the fragment being processed. Upon the import completion, a point cloud colored by default will be created in the document.

Information about the possibilities of the import dialog is discussed in more detail in the Point Cloud Import Dialog section. After the import is completed, the command history window will display diagnostic information about the export process.

## Exporting Cloud Data to DBMS

-  Ribbon: **Point Clouds > Point cloud >**  **Exporting Cloud Data to a DB**
-  Menu: **Point Clouds > Database >**  **Exporting Cloud Data to a DB**
-  Toolbar: **Point clouds >** 
-  Command line: **NPC\_TO\_DB**

The command allows you to upload a point cloud from a drawing to a storage based on PostgreSQL DBMS. At the same time, depending on whether we upload the cloud for the first time, or upload the cloud previously downloaded from the same storage (provided that the Save connection with data parameter is set to Yes during import), either a full export will occur (the storage will be newly created for this point cloud), or the cloud metadata will be incrementally

updated in the storage. Thus, the link to the DBMS created when importing from the storage allows you to save versions of the same cloud in the storage (without duplicating immutable data), creating a storage of processing stages.







Connection parameters for a command can be pre-configured using the connection bar, NPC\_DB\_CONFIG command, or requested directly in the command itself (in this case, the connection used will be saved in the connection bar automatically).

The command parameters allow you to select a storage. (illustrates work with a previously saved connection):

Parameters	
Connection name	ReCStream_1 local

Accepting the parameters will cause the import process to start immediately, the progress will be indicated by a progress indicator in the status bar of nanoCAD window. When finished, diagnostic information about the export process will be displayed in the command history window

## Configuring Connections to the DBMS

-  Ribbon: **Point Clouds > Point Cloud >**  **Configuring Connections to Database**
-  Menu: **Point Clouds > Database >**  **Configuring Connections to Database**
-  Toolbar: **Point Clouds >** 
-  Command line: **NPC\_DB\_CONFIG**

The command allows you to configure connections to existing PostgreSQL DBMS in order to create point cloud storages based on them. The main tool is the connection list bar:

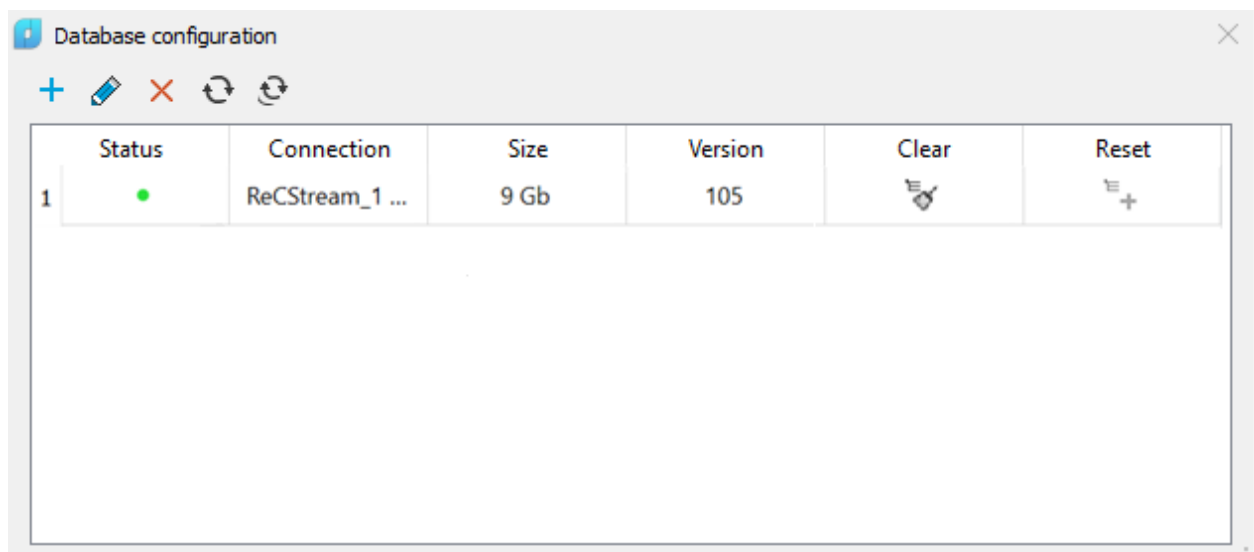

The toolkit allows you to:

- Create new connections;
- Edit saved connections;
- Delete saved connections.

### Creating new connections

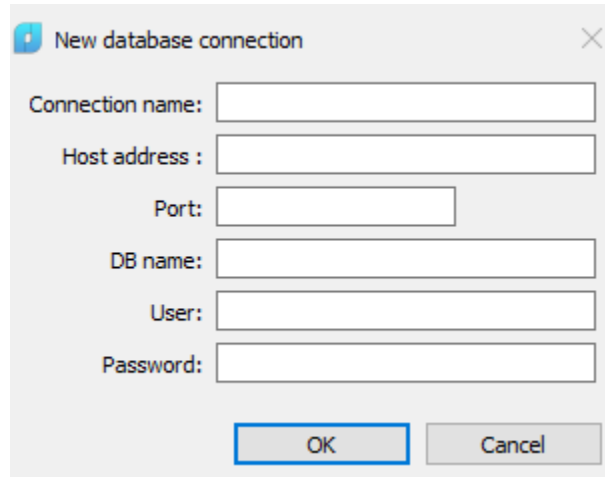



A new connection can be created by two scenarios, depending on the state of the storage in DBMS:

1. The DBMS does not contain the database we need, or it is empty and does not contain any data or structure. In this case, the connection must be registered on behalf of a DBMS user with administrative rights. You can specify the name of a non-existent database. The command script will determine that there is no such database and will offer to create it. Next, on the created or connected database, the SQL script will be launched to create the necessary structure and necessary user groups. Further, the user specified in the connection will be added to the created group of users of the point cloud storage and the process of creating the connection will be completed by checking the correctness of everything created.
2. The DBMS has a database created by other users, a storage based on it, with a customized structure, user groups, rights. In this case, you can create a connection on behalf of a common DBMS user, but he should be included in the previously created point cloud storage user group.

When a connection is created, it checks whether it is possible to work with this connection. If the connection is not working, then the user will be prompted to either refuse to create it, or save it in order to correct some of its parameters in the future.

### Checking connection status

To optimize the work with the bar, the first launch of the bar does not automatically check the status of connections, otherwise the monitoring timeout may be long. Instead, the user has a mechanism for updating the status of connections: selected in the list , or all available in the list .

The following information is available for each connection:

<b>Status</b>	<p>1. "The DB is available and has the correct structure"</p> <p>2. "The DB is available and has the incorrect structure" Such situation occurs when the major version of the DBMS structure is lower than the major version of nanoCAD storage functions structure. In this situation, the Reset button will be available.</p> <p>3. "The user does not have access rights to the DB" Such situation occurs when connecting to an existing database, if the DBMS user connecting is not included in the point cloud storage users group. To eliminate it, contact the DBMS administrator, who must enter the user into the user group of this point cloud storage.</p> <p>4. "The DB is not available" Such situation occurs if for some reason this connection could not be established. You need to check your connection details. And contact the DBMS administrator.</p>
<b>Connection</b>	The connection name cannot be edited. To change the connection name, you need to recreate the connection.
<b>Size</b>	The size of the data in the database.
<b>Version</b>	The database structure version consists of a major version and a minor one. The major one describes the data structure, the minor one describes the set of functions and stored procedures. Changing the major version (in the new nanoCAD version) requires re-creation of the storage and can only be performed by the user's explicit choice through the Reset button, and all data in the storage will be lost. Changes to the minor version of the structure can be made invisible to the user by automatic update. It does not threaten the integrity of the data in the storage. Automatic updates are checked and performed when the connection statuses are updated in the connection list bar.

In addition, two actions are available depending on the connection status:

- Clearing the existing DB
- Updating the structure of an existing DB

### Alternative DB Configuration

The connection list bar allows you to create a database and fully configure it for use as a storage for point clouds. If desired, you can configure the database through the PostgreSQL DBMS administrative tools. DB creation script:

```
CREATE DATABASE «Name» WITH OWNER = recs_admin TEMPLATE = 'template0'
ENCODING = 'SQL_ASCII' TABLESPACE = pg_default LC_COLLATE = 'C' LC_CTYPE =
'C' CONNECTION LIMIT = -1;
```

It is also necessary to preliminary create the **recs\_user** user group and the **recs\_admin** superuser included in it, on behalf of which the database should be created. When creating a database, these groups need to set the rights to work with the created DBMS:

```
CREATE ROLE recs_user WITH LOGIN INHERIT CREATEROLE PASSWORD "Password";
CREATE ROLE recs_admin WITH LOGIN SUPERUSER INHERIT CREATEROLE CREATEDB
PASSWORD "Password";
GRANT recs_user TO recs_admin;
SET ROLE recs_admin;
GRANT USAGE ON SCHEMA public TO recs_user;
GRANT ALL ON ALL TABLES IN SCHEMA public TO recs_user;
GRANT ALL ON ALL SEQUENCES IN SCHEMA public TO recs_user;
```



```
GRANT ALL ON ALL FUNCTIONS IN SCHEMA public TO recs_user;  
ALTER DEFAULT PRIVILEGES IN SCHEMA public GRANT ALL ON TABLES TO recs_user;  
ALTER DEFAULT PRIVILEGES IN SCHEMA public GRANT ALL ON SEQUENCES TO recs_user;  
ALTER DEFAULT PRIVILEGES IN SCHEMA public GRANT ALL ON FUNCTIONS TO recs_user;
```

Connection settings are saved in a protected **.Default.dbcfg** file.

## Managing Point Cloud Revisions in the DBMS



Ribbon: **Point Clouds > Database >**  **Managing Point Cloud Revisions in the Database**



Menu: **Point Clouds > Database >**  **Managing Point Cloud Revisions in the Database**



Command line: **NPC\_EDIT\_DB**

The tool for managing point clouds revisions in a selected Database.

## Point Clouds Data Formats

Point clouds are datasets of vertex data in a three-dimensional coordinate system, usually defined by X, Y, and Z coordinates. The most common method for obtaining point cloud data is the use of 3D laser scanners or photogrammetric image processing techniques in software.

3D scanners use LiDAR technology, a remote sensing technology that uses laser pulses to collect data. The LiDAR system calculates how long it takes for the laser light wave to reach the target and return to the scanner using the speed of light, which is 299 792 458 m/s.

The measurement principles used in 3D scanners are pulsed and phase distance measurement methods, as well as a direct angular sweep method (triangulation method).

Laser 3D scanning technology is the most common method for obtaining point clouds.

## Supported Formats of Point Cloud Files

There are several file formats for storing point cloud data, which, in addition to 3D coordinates, can carry additional information - metadata (attributes). Some metadata are the result of the scanner operation (scan color, intensity, echo number, scan angle, end-of-beam, edge of flightline, source ID, time), and some are added to 3D coordinates when working with the cloud (class, normal, deviations, geometry).

### LAS

Initially, lidar data are received exclusively in ASCII format. With the accumulation of large amounts of lidar data, a binary format called LAS began to be used for work and became the standard format for organizing and distributing laser data. Lidar data in LAS format is quite common nowadays. LAS is the most suitable format because files in this format contain more information and, being binary, they can be read more efficiently when imported.

LAS is an industry standard developed and used by the American Society for Photogrammetry and Remote Sensing (ASPRS). LAS is a standard file format for exchanging lidar data. It stores specific information related to lidar data. It is a way of exchanging data for suppliers and consumers, and storing all information specific to this data.

Each LAS file contains lidar metadata in a header block, followed by an individual entry for each laser pulse. The header portion of each LAS file contains attribute information about the lidar survey: data extents, date of flight, number of points recorded, number of echo points, any

additional data, and applied scale factors. The following lidar point data attributes are stored in the LAS file for each laser pulse: X, Y, Z coordinates, GPS time, intensity, echo number, echo count, point classification values, scan angle, additional RGB values, scan direction, edge of flightline, user data, point source ID, wave information. The processed LAS file can include points classified as **Ground, Low Vegetation, High Vegetation, Building**, and so on.

*Classification codes for LAS versions 1.1 – 1.4 assigned by ASPRS*

<b>Classification value</b>	<b>Meaning</b>
<b>0</b>	Never classified
<b>1</b>	Not assigned
<b>2</b>	Ground
<b>3</b>	Low Vegetation
<b>4</b>	Medium Vegetation
<b>5</b>	High Vegetation
<b>6</b>	Building
<b>7</b>	Low Point
<b>8</b>	Reserved*
<b>9</b>	Water
<b>10</b>	Rail
<b>11</b>	Road surface
<b>12</b>	Reserved*
<b>13</b>	Wire – Guard (Shield)
<b>14</b>	Wire - Conductor (Phase)
<b>15</b>	Transmission Tower
<b>16</b>	Wire Structure Connector (Insulator)
<b>17</b>	Bridge Deck
<b>18</b>	High Noise
<b>19-63</b>	Reserved

## **LAZ**

LAZ – LASzip- LAS format file compressed without data loss.

## ***BIN (Terrasolid format)***

Format of *Terrasolid* company.

The file structure looks as follows:

XYZ	XYZ	XYZ	XYZ	XYZ	XYZ	XYZ	XYZ	XYZ	XYZ	XYZ	XYZ
XYZ	XYZ	XYZ	XYZ	XYZ	XYZ	XYZ	XYZ	XYZ	XYZ	XYZ	XYZ
Time	Time	Time	Time	Time	Time	Time	Time	Time	Time	Time	Time
Time	Time	Time	Time	Time	Time	Time	Time	Time	Time	Time	Time
Intensity	Intensity	Intensity	Intensity	Intensity	Intensity	Intensity	Intensity	Intensity	Intensity	Intensity	Intensity
Intensity	Intensity	Intensity	Intensity	Intensity	Intensity	Intensity	Intensity	Intensity	Intensity	Intensity	Intensity
Line	Line	Line	Line	Line	Line	Line	Line	Line	Line	Line	Line
Line	Line	Line	Line	Line	Line	Line	Line	Line	Line	Line	Line
Scanner	Scanner	Scanner	Scanner	Scanner	Scanner	Scanner	Scanner	Scanner	Scanner	Scanner	Scanner
Scanner	Scanner	Scanner	Scanner	Scanner	Scanner	Scanner	Scanner	Scanner	Scanner	Scanner	Scanner
Echo	Echo	Echo	Echo	Echo	Echo	Echo	Echo	Echo	Echo	Echo	Echo
Echo	Echo	Echo	Echo	Echo	Echo	Echo	Echo	Echo	Echo	Echo	Echo
Angle	Angle	Angle	Angle	Angle	Angle	Angle	Angle	Angle	Angle	Angle	Angle
Angle	Angle	Angle	Angle	Angle	Angle	Angle	Angle	Angle	Angle	Angle	Angle
Class	Class	Class	Class	Class	Class	Class	Class	Class	Class	Class	Class
Class	Class	Class	Class	Class	Class	Class	Class	Class	Class	Class	Class

Point cloud attributes are stored in blocks: first a point coordinate block, then a time block, then an intensity block, etc.

The advantages of block storage:

- Possibility to read only the necessary attributes of points, this saves RAM and reduces the time for reading a file;
- You can save only the required attributes;
- Time stamps are now stored in **GPS Standard Time** format.

## PTX (Leica Cyclone Format)

Format of *Leica* company, *Cyclone* program.

A simple text file for storing point cloud data. Consists of a series of header lines followed by lines consisting of vertices (X, Y, Z), scalar coordinates, and R, G, B color values, each ranging from 0 to 255 (sometimes floating).

The Leica header looks as follows.

```
number of columns
number of rows
st1 st2 st3 ; scanner registered position
sx1 sx2 sx3 ; scanner registered axis 'X'
sy1 sy2 sy3 ; scanner registered axis 'Y'
sz1 sz2 sz3 ; scanner registered axis 'Z'
r11 r12 r13 0 ; transformation matrix
r21 r22 r23 0 ; this is a simple rotation and translation 4x4 matrix
r31 r32 r33 0 ; just apply to each point to get the transformed coordinate
tr1 tr2 tr3 1 ; use double-precision variables
```

All point clouds in PTX format usually have brightness information, so every cloud will have this attribute. Color data is determined if there are seven elements on the dot line.

The coordinates of cloud points are calculated using the position recorded by the scanner, as well as the position of the scanner and the transformation matrix.

If the scanner position is specified in the user interface, the transformation matrix in the PTX header is still used to calculate the points coordinates.

## E57

The most common file format for storing and exchanging 3D laser scanning data.

In general, an E57 file consists of a 48-byte header, a series of data blocks, and an XML section. The entire file, including the header, is divided into 1024-byte "pages", 1020-byte data, and 4 bytes at the end as a checksum. This chunk nature even applies to the XML text / readable section after all chunks of data.

Example:

```
struct E57FileHeader {
    char        fileSignature[8];
    uint32_t    majorVersion;
    uint32_t    minorVersion;
    uint64_t    filePhysicalLength;
    uint64_t    xmlPhysicalOffset;
    uint64_t    xmlLogicalLength;
    uint64_t    pageSize;
}
```

The E57 data format is supported by static and mobile 3D scanners, which are used to calculate point coordinates.

With mobile devices, point clouds and trajectory data are linked using time stamps. Therefore, at least one E57 scan should contain a field for timestamps. Trajectory information is required to import scan results from mobile devices. The trajectory file should contain a list of scanner positions associated with timestamps. The positions should be specified in the same coordinate system as the point cloud coordinates, and the trajectory timestamps should match the timestamps of the points.

Trajectory example:

```
Time;X;Y;Z
189321.10;15.96;-52.12;133.68
189321.20;15.21;-51.21;134.01
189321.30;14.75;-50.37;134.35
189321.40;14.10;-49.50;134.31
189321.10;13.78;-48.69;134.43
...
```

## PTS

This is a simple text file obtained from LIDAR scanners. The first line contains the number of lines. Each subsequent line has 7 values, the first three are the coordinates (X, Y, Z) of the point, the fourth is the "intensity" value, and the last three are the color estimates (R, G, B). The R, G, B values range from 0 to 255 (one unsigned byte). The intensity value is an estimate of the fraction of incident radiation reflected by the surface at that point.

Example:

```
253730194
-0.41025 -2.0806 8.00981 55 52 44 65
-0.63016 -1.84527 6.59447 228 228 230 225
-0.4766 -2.14446 7.91288 60 56 54 68
-0.52017 -1.51698 7.91458 60 58 50 71
-0.626 -2.46051 7.35187 152 140 160 161
-0.62371 -1.53502 7.46876 168 163 175 175
-0.62829 -2.27286 6.34905 208 204 213 212
-0.62614 -2.48739 7.36484 151 144 155 159
: : :
: : :
: : :
```

## PCD

The format is created to optimize point cloud data, currently the latest version is 0.7 (PCD\_V7).

Each PCD file contains a header that identifies and declares specific properties of the point cloud data stored in the file. The PCD header must be ASCII encoded. Header entries must be listed in the exact order shown below:

```
VERSION  
FIELDS  
SIZE  
TYPE  
COUNT  
WIDTH  
HEIGHT  
VIEWPOINT  
POINTS  
DATA
```

## **TXT**

Simple text format of 3-dimensional coordinates, separated by spaces, contains at least 3 columns of data (X, Y, Z).

## **XYZ**

This is a simple text format for the coordinates of 3-dimensional points, separated by spaces, containing 7 fields per point. The problem is that due to the lack of specifications for the content of the point cloud file, the content of the fields can vary depending on where and by whom it was created. The main thing is that the first 3 columns always represent the X, Y, Z coordinates, and the rest of the columns represent some scalar field associated with this point (R, G, B or Nx, Ny, Nz, etc.).

XYZ format can be presented in both text and binary types.

## **XYB (Faro)**

The binary format of the XYZ file. It can also contain attribute data in addition to the coordinates of points.

## **PLY**

A polygonal storage format for graphic objects that are described as a set of polygons. The file format has two representations - text and binary. The PLY format contains the description of vertices, faces and other elements, their properties such as color, surface normal, textures, transparency, and various properties for the top and bottom surfaces of polygons. Typical information contains only two elements: the coordinates (X, Y, Z) for the points vertices and the vertex indices for each face.

The PLY format supports the creation of new properties for objects, but if new properties are not understood or defined in third-party software, they can be ignored.

The structure of a typical PLY file:

```
Header  
Vertex List  
Face List  
(lists of other elements)
```

## **NPC (nanoCAD Point Cloud Storage Format)**

It is the main format for storing and exchanging point cloud data in the *nanoCAD* environment.

The NPC format is a spatially indexed optimized container for a single point cloud with support for levels of detail. The format is capable of storing not only the cloud geometry, but also meta-information: the echo intensity, the number of echos, signs of the scanning system position for the data obtained during laser scanning, the point color, the point class, its belonging to geometric shapes, the data source ID and the time of its registration, as well as calculated information: normal and curvature at a point. The structure of the container allows you to work with it by partially projecting data into memory.

## RCS (ReCap Format)

Point cloud storage format of the Autodesk ReCap software after importing scanned point cloud files into it (formats that are indexed in ReCap: ASC, CL3, CLR, E57, FLS, FWS, ISPROJ, LAS, PCG, PTG, PTS, PTX, RDS (3D only), TXT, XYB, XYZ, ZFS, ZFPRJ). Point cloud data saved in RCS format are in meters.

## RCP (Autodesk Native Format)

The file format is a project file that groups multiple scan files at the same time. RCS, which actually contains links to individual RCS files and contains information about them and preview files. The result of indexing a source format file is a .RCP file and one or more .RCS files. The internal structure of the file is xml

## Extract from View



Ribbon: **Point Clouds > Point Cloud >**  **Extract from View**



Menu: **Point clouds >**  **Extract from view**



Command line: **NPC\_EXTRACT\_FROM\_VIEW**

This command extracts points from viewport to a new point cloud. If source point cloud was clipped with one of clip or section commands, then only visible points includes in a new cloud. If point cloud has a **Class** attribute then only points from visible unblocked and unfrozen layers will be extracted. All metadata remains unchanged, new point cloud object will be created on the current layer.

### Command Prompt:

Use all clouds in view? <No>  
or [Yes/No]:

This prompt is displayed when there are more than one point cloud in the viewport.

### Command options:

Yes Creates one point cloud that includes all visible points of all point clouds of the viewport. All points, which are invisible in active viewport, because they are outside viewport margins, will be also extracted.

No Displays the prompt:  
Select point clouds or [?]:  
Specify the cloud to be extracted or select the ?.option

? Displays the selection prompt:  
Select an option or [Window/Last/Crossing/Box/All/Fence/WPolygon/CPolygon/Group/Add/Remove/Previous/Auto]:

that allows you to select a cloud using various options (see [Selection of](#)

[objects using the command line options](#) section)

## Create a New Cloud Based on Clipping



Ribbon: **Point Clouds – Point Cloud** >  **Create from View**



Menu: **Point Clouds** >  **Create from View**



Command line: **NPC\_CROP\_FROM\_VIEW**

The command creates a new point cloud from the crop of the existing cloud. In this case the source point cloud is deleted.

### To create a new cloud from crop:

1. Go to the model space viewport containing the clipped cloud and run the command.
2. If there are several clouds the command line will show a prompt to specify the necessary:

Use all clouds in VScreen? <No> or [Yes/No]:

3. After specifying, the selected clouds will be deleted, and new ones will be created in their place from their clippings.

**NOTE:** when which command is undone, clipping on the source clouds is not restored.

## Point Clouds Coordinates Transformation

### Transformation to Default Coordinates



Ribbon: **Point Clouds – Point Cloud** >  **Transform to Default Coordinates**



Menu: **Point Clouds** >  **Transform to Default Coordinates**



Command line: **NPC\_TRANSFORM\_TO\_DEFAULT\_COORDINATES**

The command allows you to convert point cloud coordinates from the Own or User coordinate system to the World coordinate system.

It is usually used to transform the coordinates of those clouds that were taken in the own coordinate system.

### Command prompts:

Do you want to transform object coordinates from UCS to WCS or from OCS to WCS <OCS> or [UCS/OCS]:

Specify from which system the cloud coordinates should be converted to the World coordinate system: from UCS or OCS.

## Recalculation of Point Cloud Coordinates by EPSG

 Ribbon: **Point Clouds – Point Cloud** >  **Recalculation of Point Cloud Coordinates by EPSG**

 Menu: **Point Clouds** >  **Recalculation of point cloud coordinates by EPSG**

 Command line: **NPC\_EPSG\_REPROJECTION**

If the loaded point cloud has geocoordinates, the command allows you to recalculate them to another system using EPGS codes. This creates a new cloud for the target coordinate system.

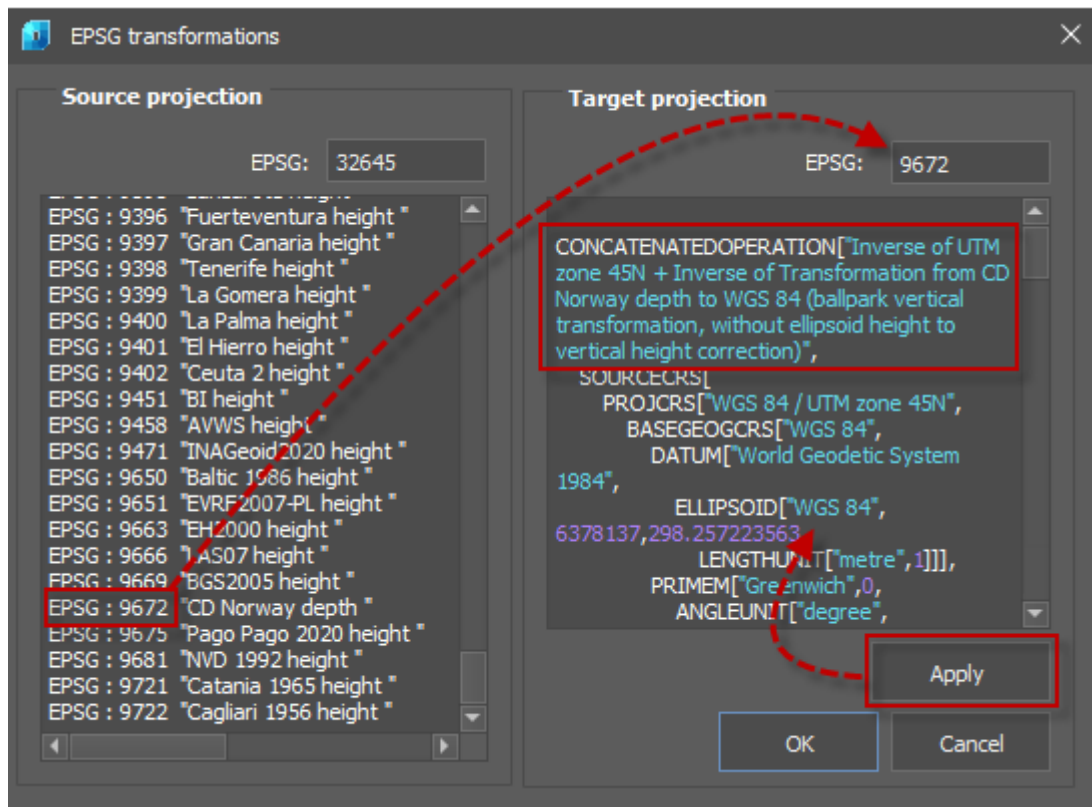

**NOTE:** The **Recalculation of point cloud coordinates** and **Recalculation of point cloud coordinates by EPSG** commands are mutually exclusive. Use one of them to convert geocoordinates of a cloud.

### To recalculate coordinates:

1. Run the command.
2. In the right text field of the dialog that appears, enter the number of the target coordinate system according to the EPGS classification, based on the information in the left part of the window. Click **Apply**.
3. Information on the selected target geocoordinate system will appear in the right part of the dialog box. Click **OK** to confirm the conversion.

Information about the current geocoordinate system of the cloud can be viewed by clicking the button from the **Properties** bar (**Geoinfo** bar) or from the **Coordinate system information** dialog.



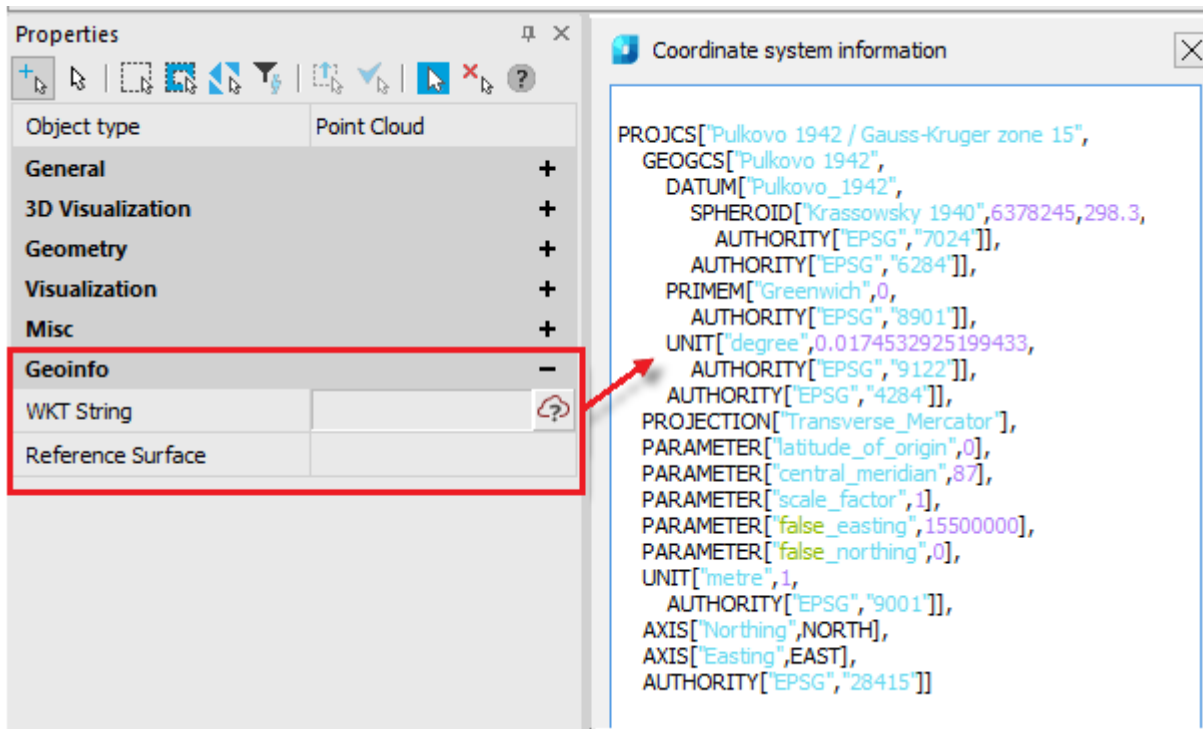





## Point Clouds Display Settings





### Display Settings

#### Display boundary

-  Ribbon: **Point Clouds – Settings** >  **Switch point cloud boundary**
-  Menu: **Point Clouds – Settings** >  **Display point cloud boundary**
-  Command line: **SWITCHPCBOUNDARY**

Enable/disable boundary box of each point cloud in the drawing. By default, this mode is turned off, as a result of which bounding contours are not displayed.

#### Display All Points

-  Ribbon: **Point Clouds – Settings** >  **Switch point cloud display tree**
-  Menu: **Point Clouds – Settings** >  **Display all points**
-  Command line: **SWITCHPCDISPLAYTREE**

Turns on / off the display of all points in the cloud. Disabled by default, so the number of points displayed on the screen depends on the performance of the PC's graphics system.

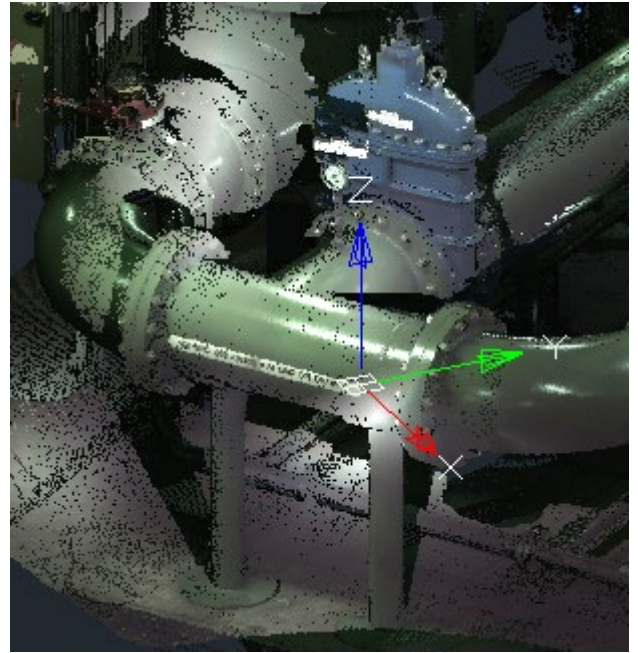

Enabling this mode only affects the speed of displaying clouds and navigation in the workspace. This mode does not affect the speed of clouds processing by commands of stitching (registration), classification, etc. To speed up cloud processing operations, make it sparse with the [Thinning the Point Cloud](#) command, which reduces not the displayed, but the actual number of points in cloud. It is also possible to reduce the number of cloud points that get into the document during the [import](#) operation by checking the **Spacing** box and specifying the sequence number of imported points.

### *Zoom Extents after Import*



Ribbon: **Point Clouds – Settings** >  **Switch point cloud import zoom extents**



Menu: **Point Clouds – Settings** >  **Zoom extents after import**



Command line: **SWITCHPCIMPORTZOOMEXTENTS**

Auto zoom extents mode to the point cloud after import.

In the majority of cases after importing it is required to zoom to the point cloud. This mode does this automatically. The mode is enabled by default.

### *Snap Point Cloud*



Ribbon: **Point Clouds – Settings** >  **Snap Point Cloud**



Menu: **Point Cloud – Settings** >  **Snap Point Cloud**



Command line: **SWITCHPCSNAPON**

Snap to separate points in **Node** object snap mode. The mode is enabled by default.

### *Snap to Geometry*



Ribbon: **Point Clouds – Settings** >  **Snap to Edges and Nodes**

 Menu: **Point cloud – Settings** >  **Snap to Edges and Nodes**

 Command line: **SWITCHPCSNAPFEATURES**

Allows you to snap to fit points of geometry, recognized in the cloud by features recognition commands.

By default, the mode is on.

To be able to snap to shapes, the **Object 3D Snap** mode should be enabled and the required snapping types should be turned on in the **Drafting Settings** dialog box called from the context menu of **O3D SNAP** button.

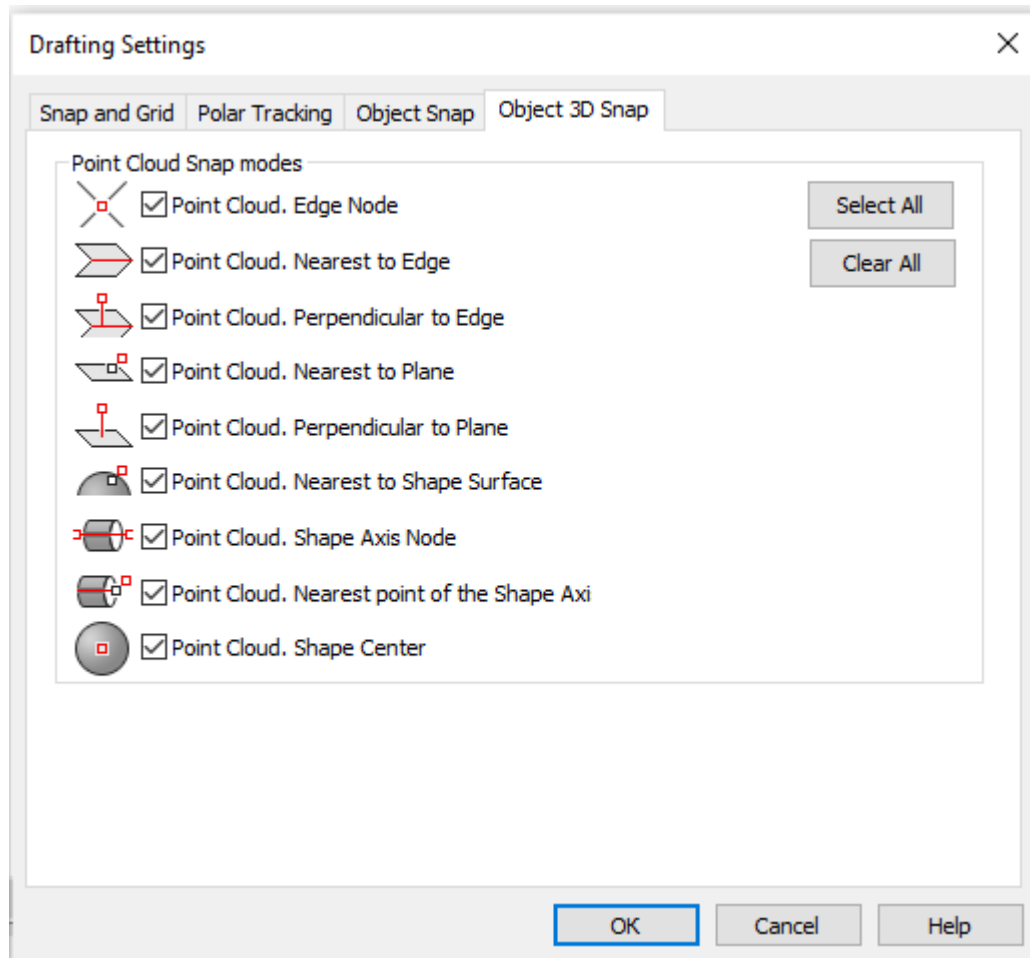

## *Point Cloud Display Style*

 Ribbon: **Point Clouds** > **Settings** >  **View Mode**

 Menu: **Point clouds** >  **View mode**

 Toolbar: **Point clouds** > 

 Functional toolbar **Properties – Visualization – Change visualization** >  button

 Command line: **NPC\_VIEWMODE**

The command opens a dialog box that allows you to stylize a point cloud in accordance with the values of these or those attributes of this cloud. In fact, the command paints each cloud point in

accordance with the attribute value in this point. The user selects the attribute by stylize by. In case the necessary attributes are present in the cloud, stylization is possible by:

- color;
- intensity;
- class;
- echo number;
- source ID.

Also, you can color point cloud by selected color or cloud elevation (along the Z axis).

**Options:**

**Point Size:**

The size of points in cloud in pixels. The size of deviation and normal vectors also depends on this parameter.

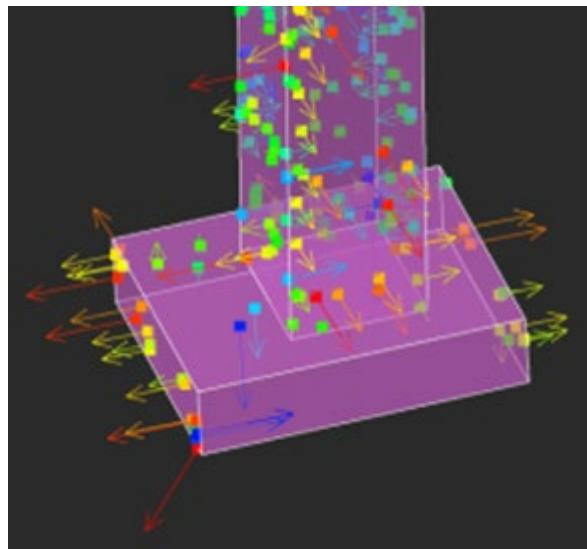

**Coloring type:**

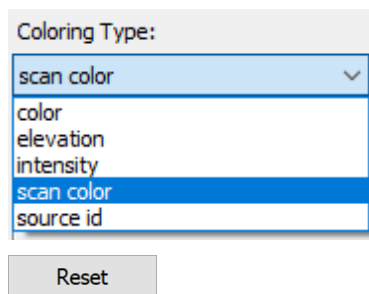

The list of available attribute values.

A drop-down list of cloud attributes available for stylization. The number of attributes in the list depends on which of them were imported together with the cloud from the scan file.

Resets to default values the **Number of Ranges** fields when coloring by height or intensity, as well as colors when selecting the type of coloring by elevation, intensity, echo number or color.

### Number of Ranges:

The number of ranges of the same color into which the entire cloud will be divided when coloring. This field is available when coloring by elevation, intensity, or deviation value. After entering a new value in the **Number of Ranges** field, click the **Update** button to recalculate ranges.

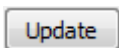
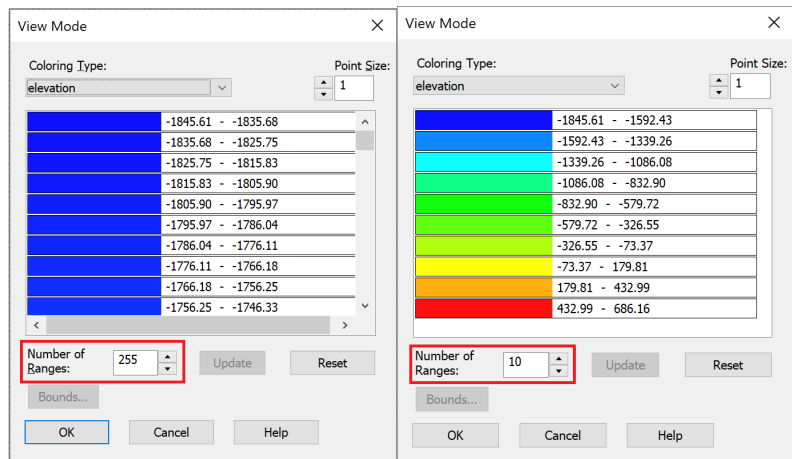

Updates the list of colors according to **Number of ranges**.

### Scan Color

Color the cloud according to points color in the source file.

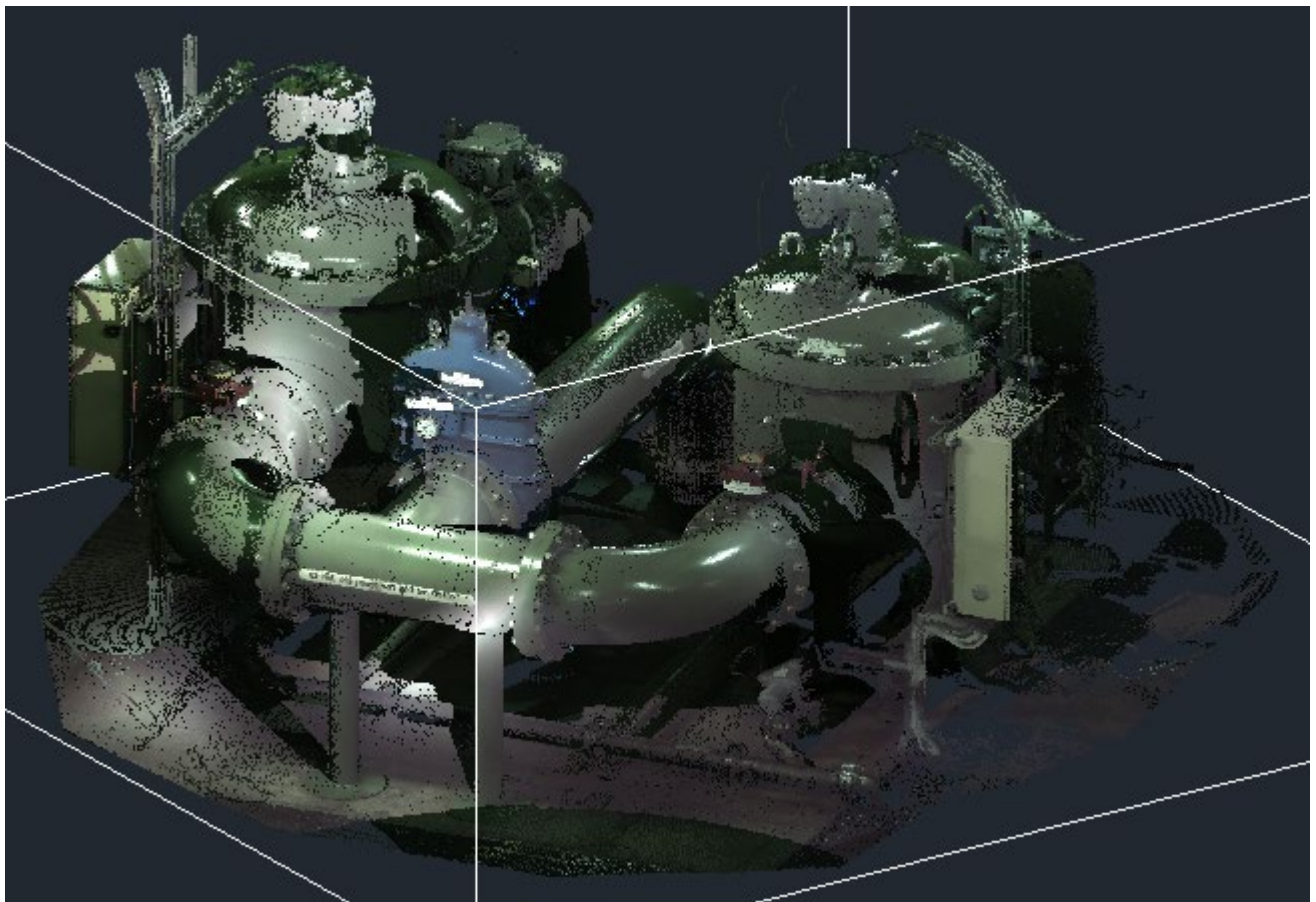

## Elevation

Coloring depends on the Z-coordinate value in each point of cloud.

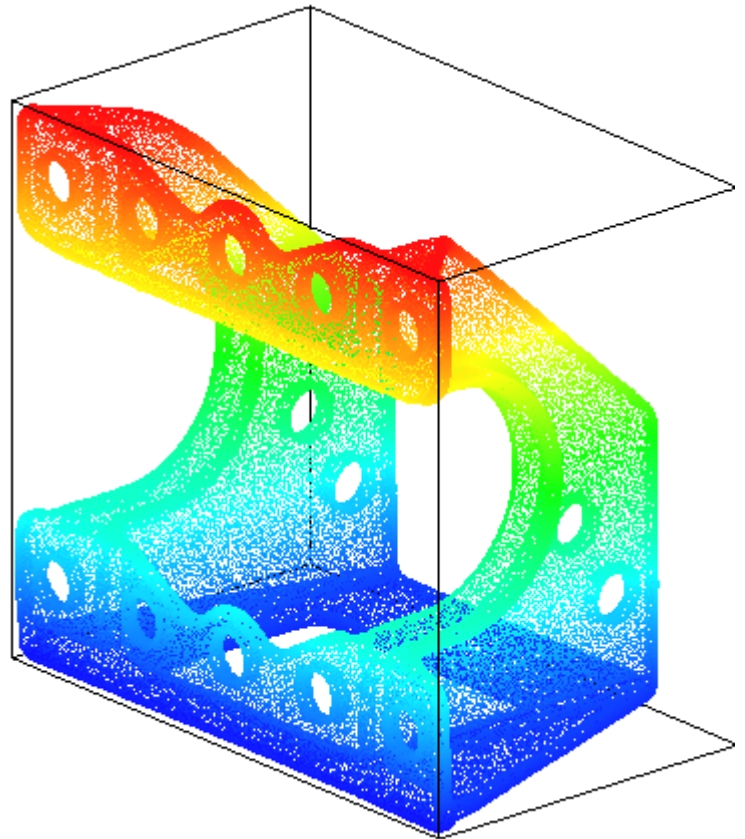
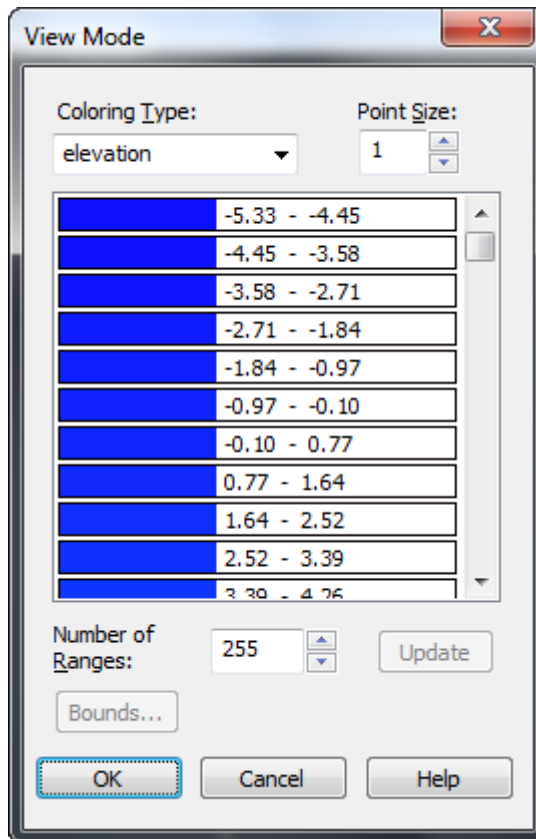

## Intensity

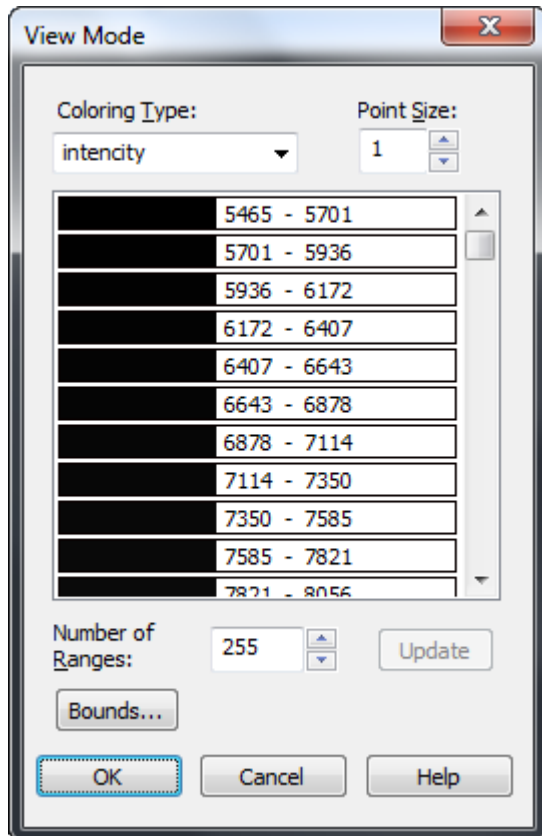

Coloring based on the intensity of the reflected pulse.

Click **Bounds** button to open chart of distribution intensity. You can exclude the part of low or upper bound using sliders.

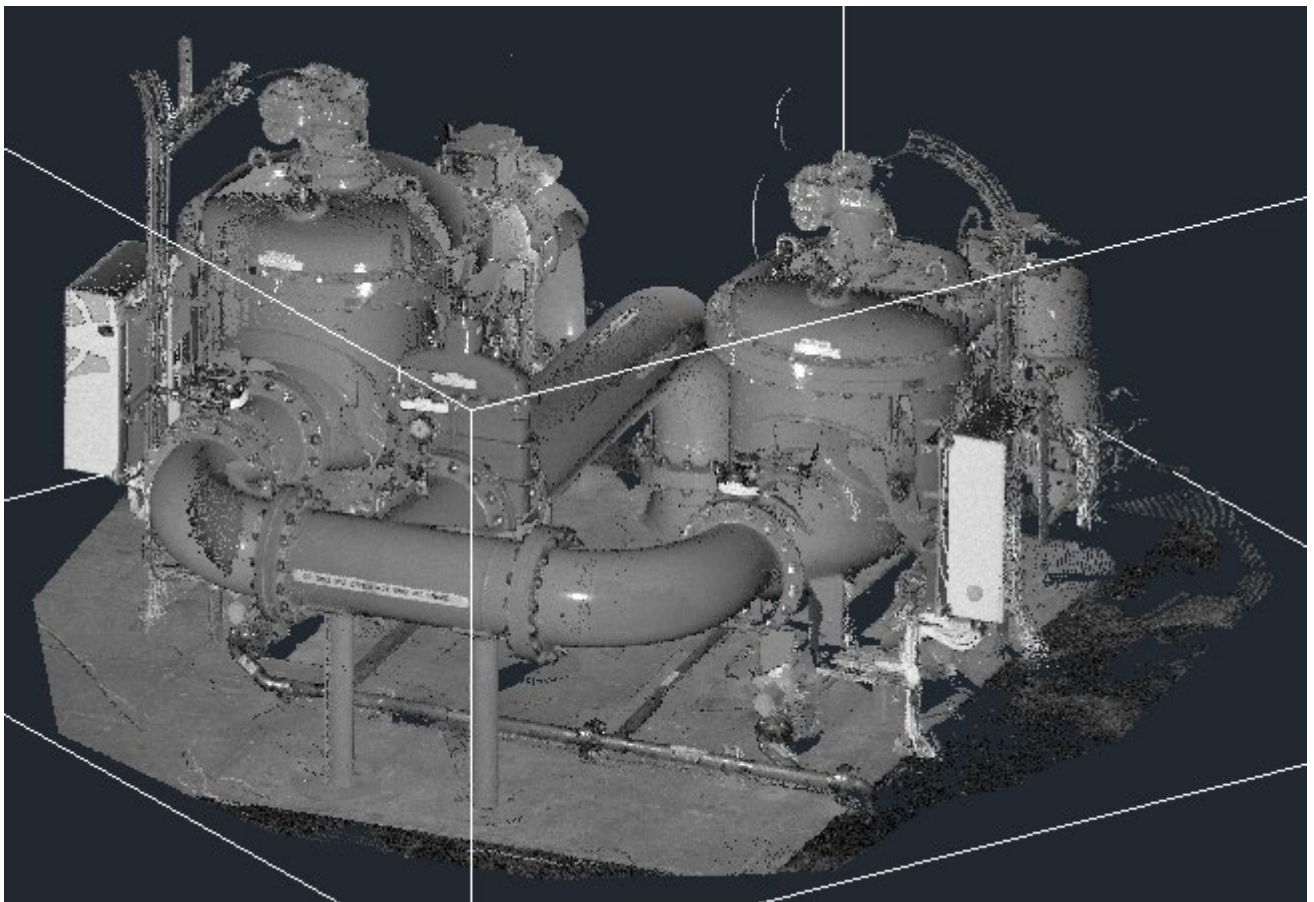
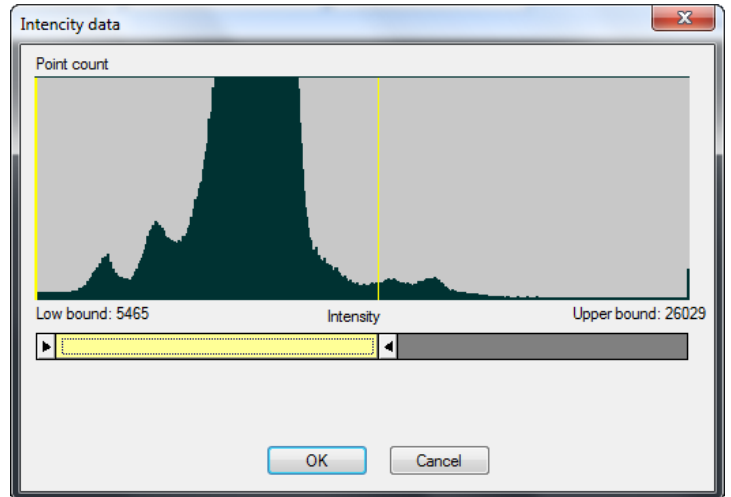

## Code

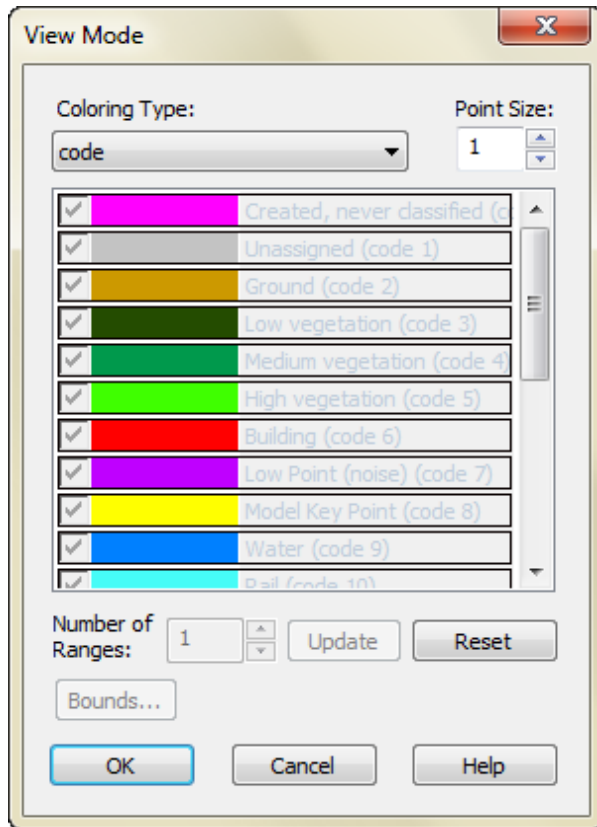

It is impossible to disable the display of classes and changes in their color, if classes were associated with layers in the document.

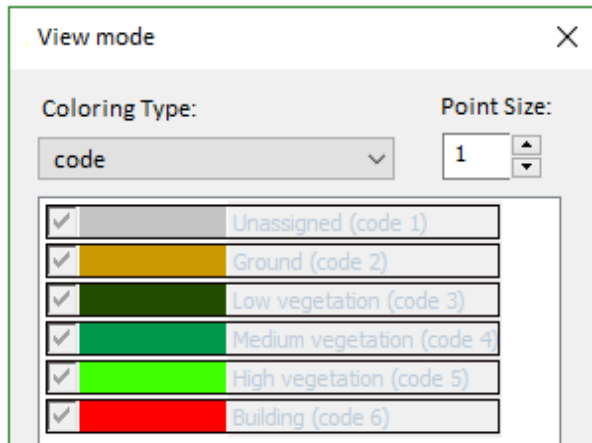

Color the cloud according to point classes. Points can be classified into a number of categories including bare earth or ground, top of canopy, and water. This coloring type may color the cloud with the Standard LAS Classification.

Unchecking the box next to the class allows you to disable the display of this class points in the drawing.

Such association occurs, for example, when importing point clouds with **Auto fill code layers** checkbox enabled.

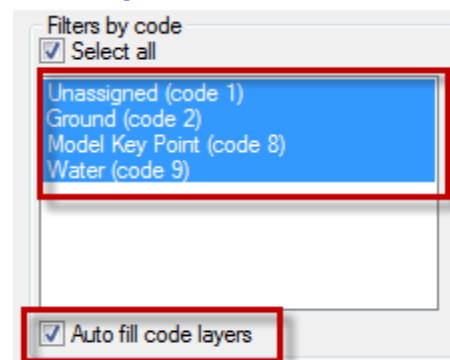

You can disable the display of class points associated with layers by disabling the display of layers in the **Layers** dialog



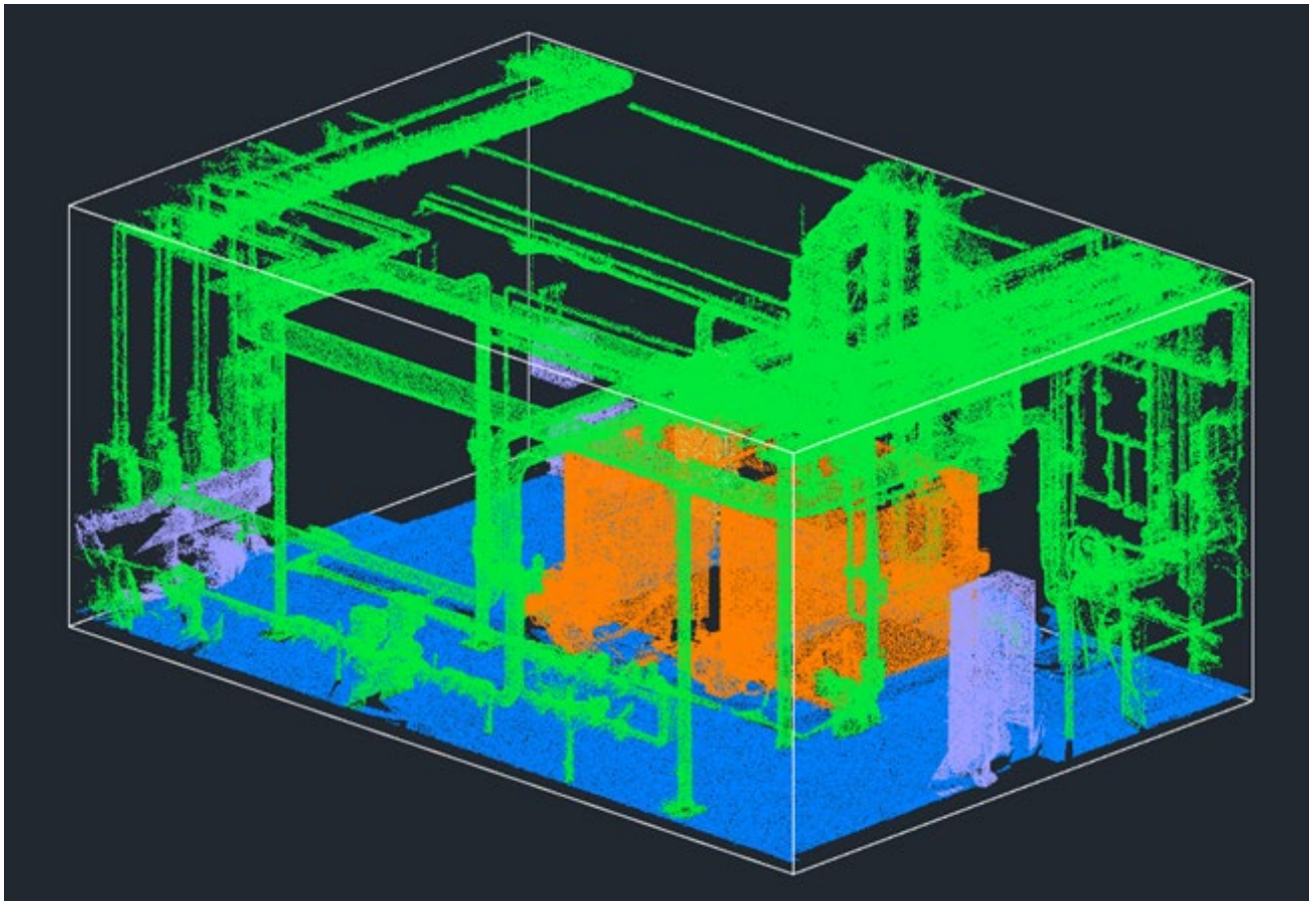

## Echo number

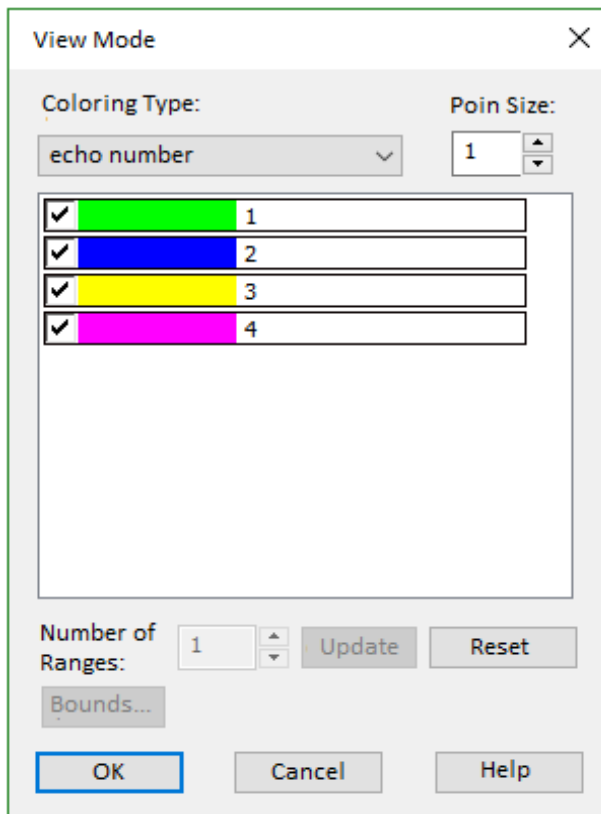

Color cloud according to reflection number of laser ray obtained as a result of scan.

It is possible to disable visibility of points of any of reflection numbers by unchecking the corresponding box.

## Color

Coloring all cloud points by selected color.

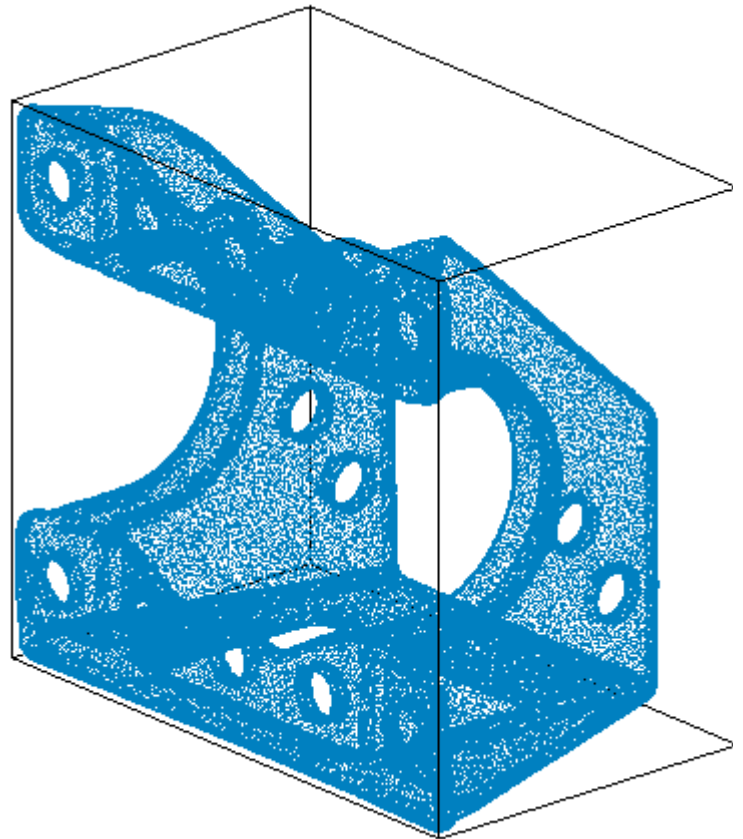
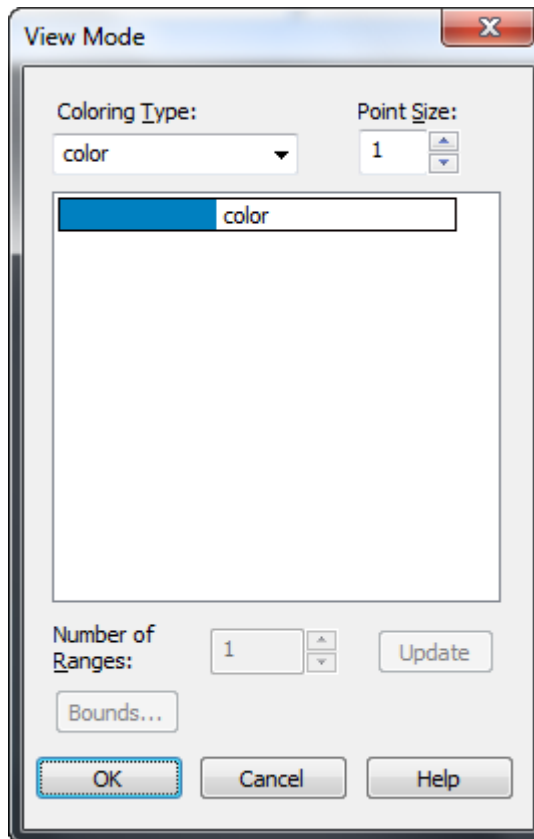

## Source ID

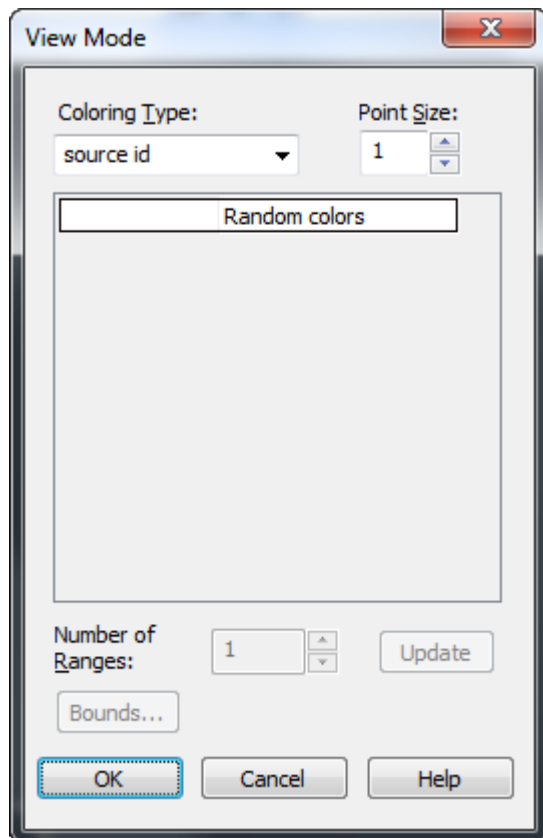

Coloring point cloud according to a unique source scan ID. One cloud can be formed as a result of several scans of one and the same object from different points. This type allows you to color the cloud points depending on the identifier of the scan source.

Program selects color for every source automatically.

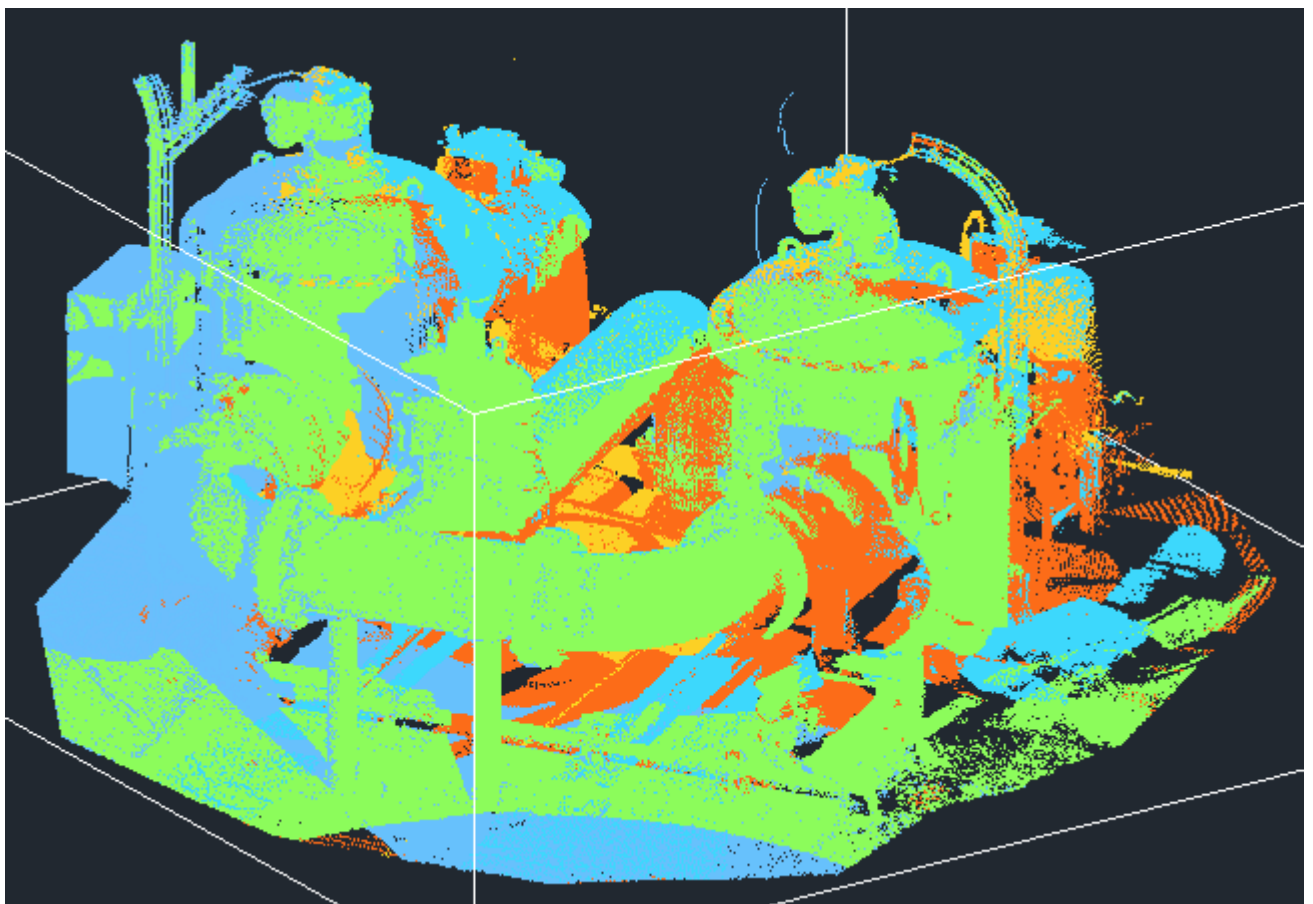

## Normal

Renders the direction of cloud point normals (**Normal** attribute), if present in the cloud. It is possible both to color the points depending on the normal direction, and to directly display the normal vectors.

Cloud points are colored according to the direction of their normals.

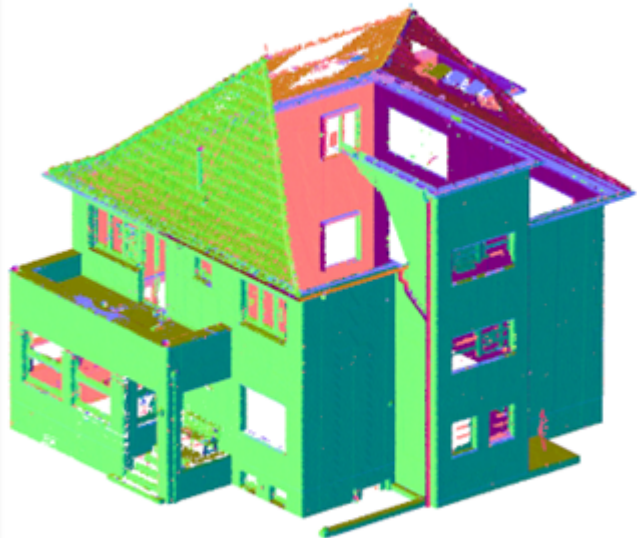
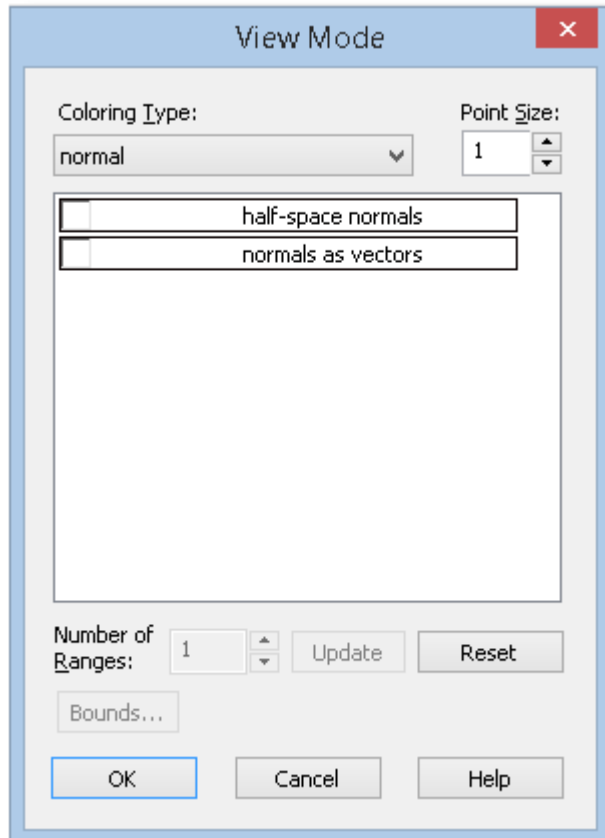

Normals are created by [cloud triangulation commands](#), [features recognition commands](#), and [fitting commands](#). Normals may not always be calculated correctly. In this case, it is recommended to recalculate the normals.

When the **Halfspace normals** box is checked, all collinear normal vectors begin to be displayed in the same color. So coloring does not distinguish between normals pointed in exactly opposite directions. This assigns them color equal to the interpolation of the colors of the axes of the current UCS. Points with normals collinear to a particular coordinate axis will have the color of that axis.

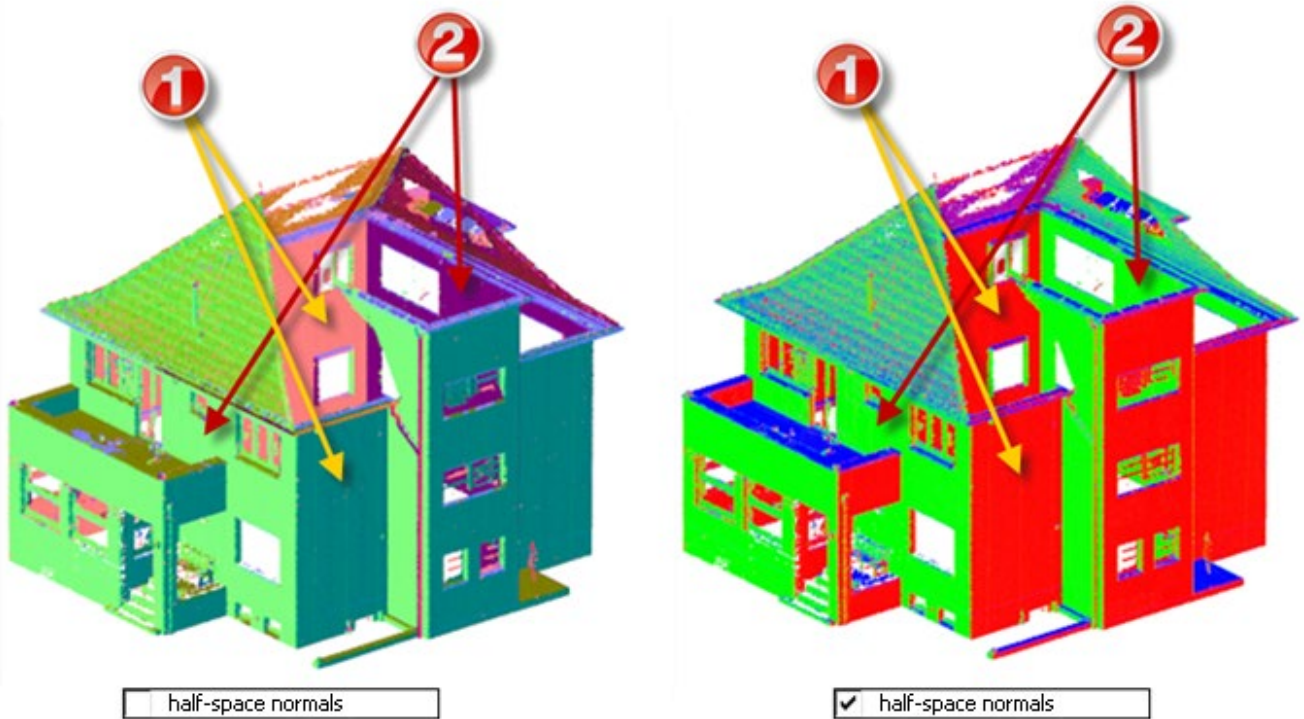

You can check the **Normals as vectors** box to display the normal vectors, and not just color the points of the cloud according to the directions of the normals. The size of the vectors on the screen depends on the size of the cloud point (**Point size** field). Normal vectors are only displayed when using DirectX as a hardware graphics accelerator.

### *Deviation value*

The **Deviation value** coloring type visualizes the size and direction of deviation of cloud points (the **Deviation** attribute) from the reference model (its vector representation or another cloud). Vertical application commands such as **Compare Point Clouds** can be used to calculate deviations.

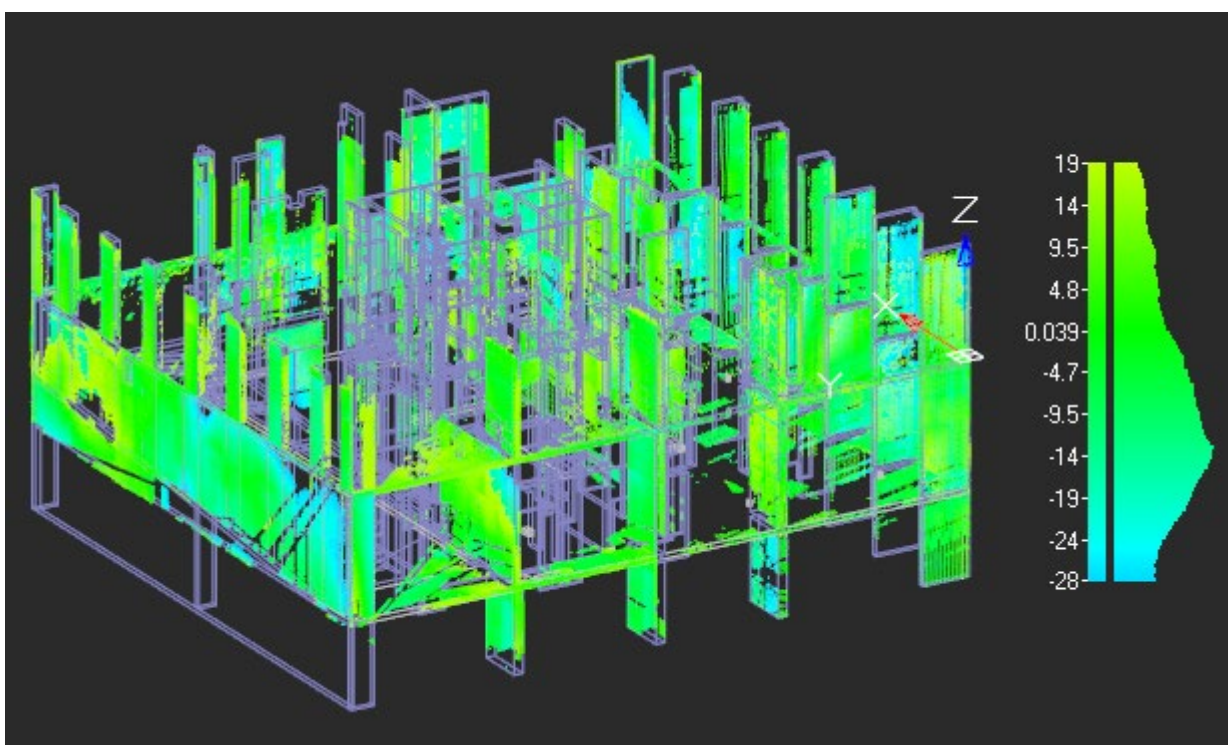

The **Bounds** button displays the histogram of deviations with possibility to cut boundary values.

To disable the display of cloud points with deviations exceeding the limits of the allowable range, adjust the range limits with the sliders and check the **Crop points** box. When the box is checked, points that do not fall into the vicinity of the set deviation error (black) will be cut off regardless of the position of the cutoff boundaries.

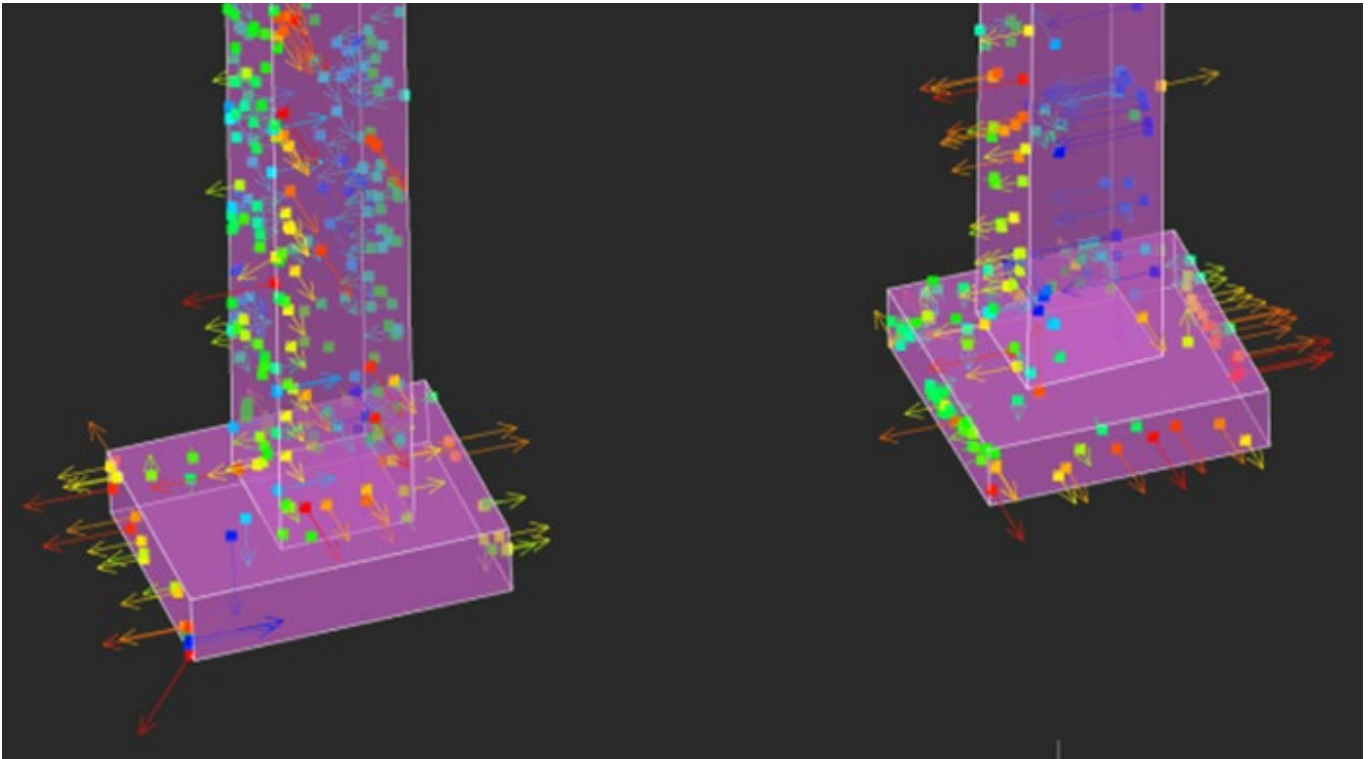

### ***Feature and Feature type***

The **Feature type** and **Feature** coloring become available for point clouds in which features have been recognized by geometry search commands (pipelines, pipeline elements, planes, plane and pipe elements). These coloring types are designed to visualize such features in the cloud.

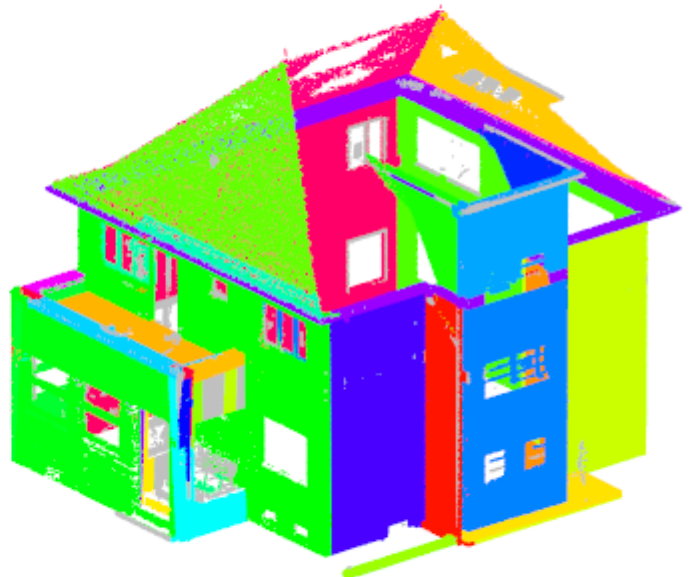
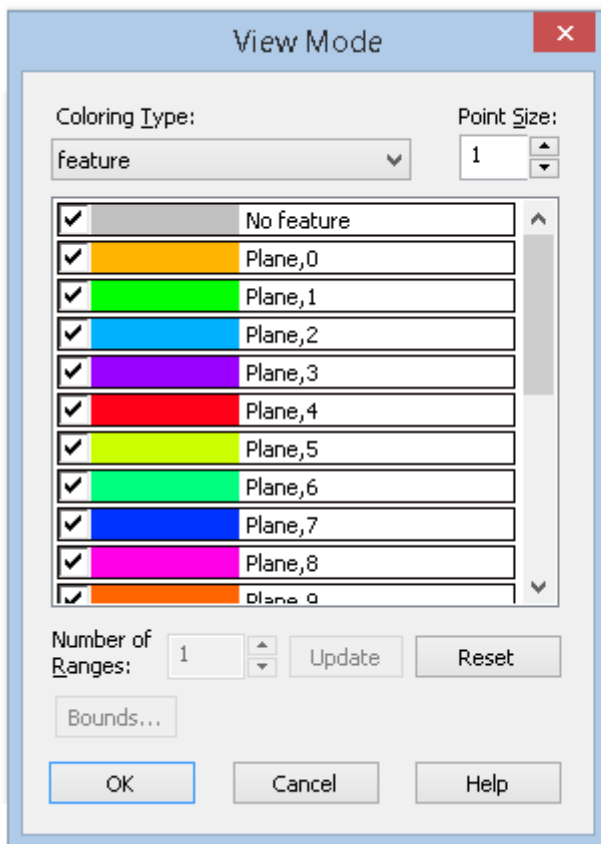
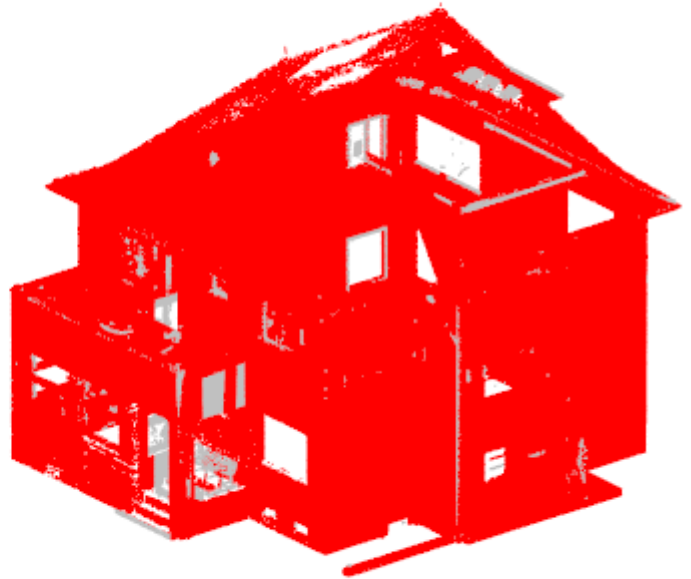
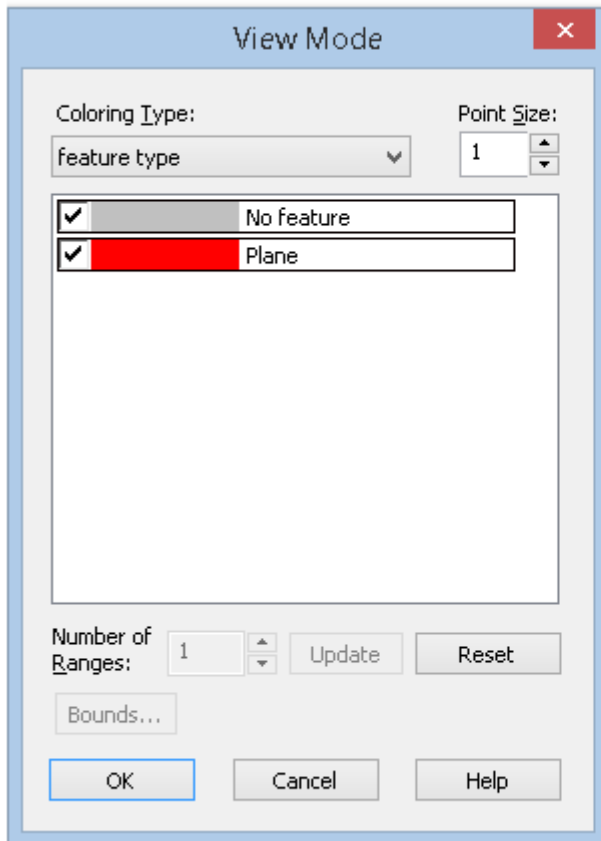

## Hiding the Point Cloud



Ribbon: **Point Clouds – Settings** >



**Hiding the Point Cloud**

 Menu: **Point Clouds** >  **Hiding the Point Cloud**

 Command line: **NPC\_HIDE**

The command allows you to hide visibility of a selected point cloud or all point clouds in a drawing. If there are no selected point clouds, then the command disables all of them. If there is a selected item(s), they will be hidden.

## Displaying a Point Cloud

 Ribbon: **Point Clouds - Settings** >  **Displaying a Point Cloud**

 Menu: **Point Clouds** >  **Displaying a Point Cloud**

 Command line: **NPC\_SHOW**

The command restores visibility of all hidden point clouds.

## Clip Point Clouds

Clip tools allow you to crop a specified area from a cloud or several clouds.

Clip area from point cloud in any view. Specify needed viewport to show clipped point cloud.

The work of clip commands changes only the cloud display in the target viewport. No changes occur to the object cloud itself. Other viewports display original cloud.

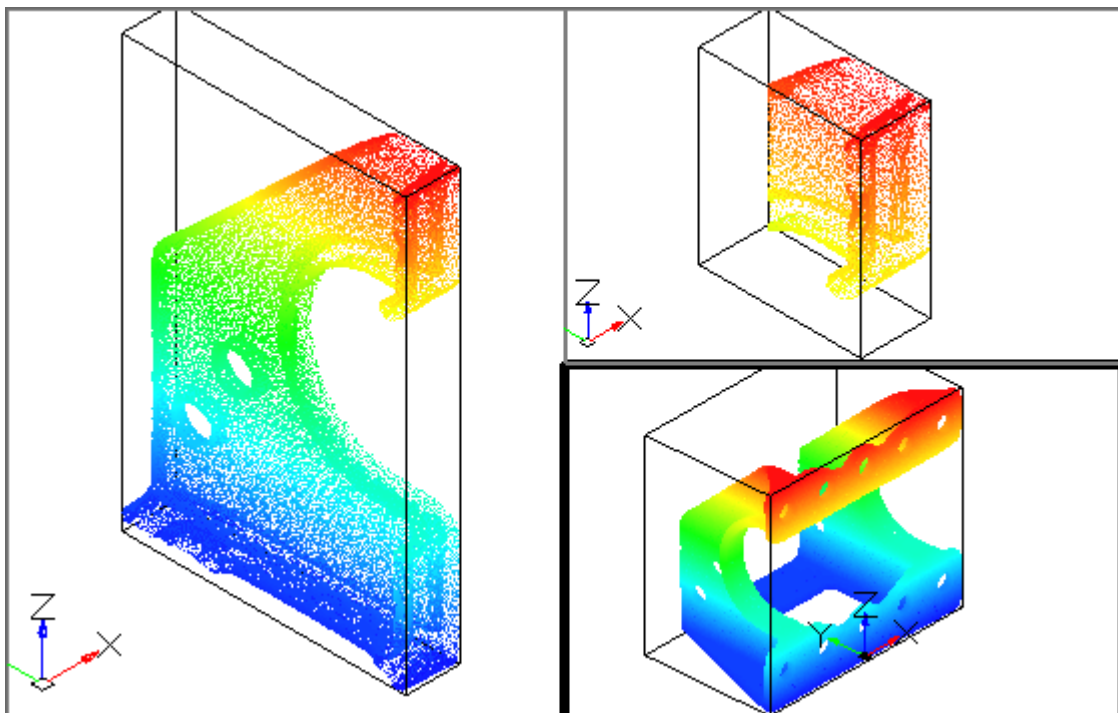





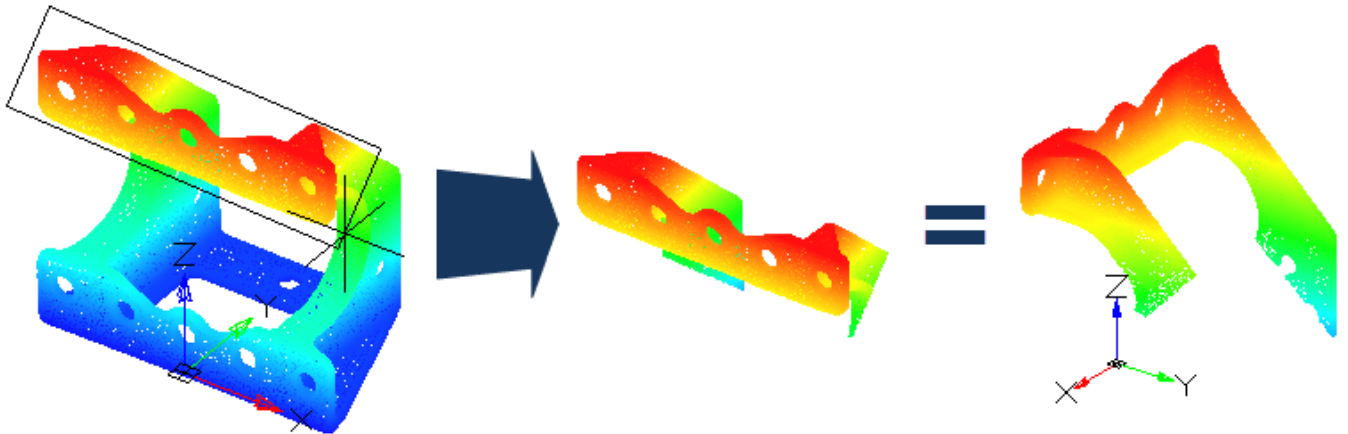







Clip boundary set in the plane of view in the eye direction. It's possible to clip the cloud in one viewport and display clipped cloud in another one. When the clip result is displayed in the target viewport, the same view will be set that was in the original viewport during clipping operation.





You may clip the cloud repeatedly. Clip undo realized by special commands: **NPC\_CLIP\_UNDO** to undo the last clip and **NPC\_CLIP\_RESET** to undo all clips. Commands are not related with standard **UNDO** command.

## Clip Point Clouds by 2 Points of Rectangle

-  Ribbon: **Point Clouds – Clip and Section – Clip** >  **Clip By 2 Points (inside)**
- Ribbon: **Point Clouds – Clip and Section – Clip** >  **Clip by 2 Points (outside)**
-  Menu: **Point Clouds – Clip** >  **Rectangle by 2 Points (inside)**
-  Menu: **Point Clouds – Clip** >  **Rectangle by 2 Points (outside)**
-  Toolbar: **Clip and Sections** >  **Clip by Orthogonal Rectangle (inside)**
-  Toolbar: **Clip and Sections** >  **Clip by by Orthogonal Rectangle (outside)**
-  Command line: **NPC\_CLIP\_RECT, NPC\_CLIP\_RECT\_INV**

Create clip boundary by two opposite points of rectangle. Boundary is perpendicular to the view plane. Its sides are orthogonal to sides of the viewport. The cloud is clipped perpendicular to the plane of the viewport in the view direction.

A cloud can be clipped in one viewport (source), with the result displayed in another viewport (target), specified by the user. When the clip result is displayed in the target viewport, the same view will be set that was in the original viewport during clipping operation.

### Command options:













- |                        |   |
|------------------------|---|
| Enter first point:     | Specify the first diagonal point of clip boundary.  |
| Enter opposite corner: | Specify the second diagonal point of clip boundary.   |
| Select view:           | Specify needed view to display the clip. This request is displayed if there are several viewports in the model space. |

As a result of the  **Clip by 2 Points (inside)** command, the cloud area inside the rectangle frame will be clipped.

As a result of the  **Clip by 2 Points (outside)** command, the cloud area outside the rectangle frame will be clipped.

Command clip only mapping of point cloud in the target view, the object cloud itself remains unchanged. The cloud remains unchanged in the rest of viewports.

## Clip Point Clouds by 3 Points of Rectangle

-  Ribbon: **Point Clouds – Clip and Section – Clip** >  **Clip By 3 Points (inside)**
-  Ribbon: **Point Clouds – Clip and Section – Clip** >  **Clip by 3 Points (outside)**
-  Menu: **Point Clouds – Clip** >  **Rectangle by 3 Points (inside)**
-  Menu: **Point Clouds – Clip** >  **Rectangle by 3 Points (outside)**
-  Toolbar: **Clip and Sections** >  **Clip by Rectangle (inside)**
-  Toolbar: **Clip and Sections** >  **Clip by Rectangle (outside)**

 Command line: **NPC\_CLIP\_RECT\_ROTATED, NPC\_CLIP\_RECT\_ROTATED\_INV**

Create rectangle clip boundary by angle and two sides. Boundary is perpendicular to the view plane. The cloud is clipped perpendicular to the plane of the viewport in the view direction.

A cloud can be clipped in one viewport (source), with the result displayed in another viewport (target), specified by the user. When the clip result is displayed in the target viewport, the same view will be set that was in the original viewport during clipping operation.

### Command options:









- |                          |  |
|--------------------------|--|
| Enter first base point:  | Specify the first point of boundary.     |
| Enter second base point: | Specify the length of the first side.    |
| Enter diagonal point:    | Specify the length of the second side.   |
| Select view:             | Specify needed view to display the clip. |

As a result of the  **Clip by 3 Points (inside)** command, the cloud area inside the rectangle frame will be clipped.

As a result of the  **Clip by 3 Points (outside)** command, the cloud area outside the rectangle frame will be clipped.

Command clip only mapping of point cloud in the target view. The cloud remains unchanged in the rest of viewports.

## Clip Point Clouds by Fence

-  Ribbon: **Point Clouds – Clip and Section – Clip** >  **Clip by Fence (inside)**
-  Ribbon: **Point Clouds – Clip and Section – Clip** >  **Clip by Fence (outside)**
-  Menu: **Point Clouds – Clip** >  **By Fence (inside)**
-  Menu: **Point Clouds – Clip** >  **By Fence (outside)**

 Toolbar: **Clip and Sections** >  **By Fence (inside)**

 Toolbar: **Clip and Sections** >  **By Fence (outside)**

 Command line: **NPC\_CLIP\_FENCE, NPC\_CLIP\_FENCE\_INV**

Clip the cloud by polygonal boundary. Boundary is perpendicular to the view plane. The cloud is clipped perpendicular to the plane of the viewport in the view direction.

A cloud can be clipped in one viewport (source), with the result displayed in another viewport (target), specified by the user. When the clip result is displayed in the target viewport, the same view will be set that was in the original viewport during clipping operation.

**Command prompts:**

- |  |   |
|--|---|
| Specify points of polyline:<br>or [ <u>Undo</u> ]: | Specify the first point of polygonal boundary.<br>Specify the second and next points of polygonal boundary. Select <u>Undo</u> to delete the last created point. Press <b>ENTER</b> to end the command. |
| Select view:                                       | Select needed view to display the clip. This request is displayed if there are several viewports in the model space.  |

As a result of the  **Clip by Fence (inside)** command, the cloud area inside the frame will be clipped.

As a result of the  **Clip by Fence (outside)** command, the cloud area outside the frame will be clipped.

Command clip only mapping of point cloud in the target view. The cloud remains unchanged in the rest of viewports.

## Clipping Clouds by Sphere

 Ribbon: **Point Clouds – Clip and Section – Clip** >  **Clip by Sphere (inside)**

 Ribbon: **Point Clouds – Clip and Section – Clip** >  **Clip by Sphere (outside)**

 Menu: **Point clouds – Clip** >  **By Sphere (inside)**

 Menu: **Point clouds – Clip** >  **By Sphere (outside)**

 Toolbar: **Clip and Sections** >  **Clip by Sphere (inside)**

 Toolbar: **Clip and Sections** >  **Clip by Sphere (outside)**

 Command line: **NPC\_CLIP\_SPHERE, NPC\_CLIP\_SPHERE\_INV**

The command clips a cloud by sphere set by central point and radius.

A cloud can be clipped in one viewport (source) with display of the result in the other viewport (target) specified by the user. When displaying the clip result in the target viewport, the same view will be set that was in the source viewport when performing the clip operation.

**Command prompts:**

- |                      |                                 |
|----------------------|---------------------------------|
| Enter central point: | Specify the clip sphere center. |
|----------------------|---------------------------------|

Enter radius or [Invert]:

Specify the clip sphere radius.

To invert the clip area, select the Invert option. In this case, the area outside the sphere will be clipped.

Select view:

Specify the target viewport, in which to display the clip. This prompt is displayed in case there are several viewports in the model space.

As a result of the  **Clip by Sphere (inside)** command, the cloud area inside the sphere will be clipped.

As a result of the  **Clip by Sphere (outside)** command, the cloud area outside the sphere will be clipped.

Only display of the cloud in the target viewport is changed as a result of the command work, the cloud object itself is not changed. Display of the cloud in other viewports remains the same.

## Clipping Clouds by Cylinder



Ribbon: **Point Clouds – Clip and Section – Clip** >  **Clip by Cylinder (inside)**



Ribbon: **Point Clouds – Clip and Section – Clip** >  **Clip by Cylinder (outside)**



Menu: **Point clouds – Clip** >  **By Cylinder (inside)**



Menu: **Point clouds – Clip** >  **By Cylinder (outside)**



Toolbar: **Clip and Sections** >  **Clip by Cylinder (inside)**



Toolbar: **Clip and Sections** >  **Clip by Cylinder (outside)**



Command line: **NPC\_CLIP\_CYLINDER, NPC\_CLIP\_CYLINDER\_INV**

The command clips a cloud by cylinder area set by central point and radius. The cylinder bases are collinear to the plane of the viewport. A cloud is clipped perpendicular to the viewport plane in the direction of view.

A cloud can be clipped in one viewport (source) with display of the result in the other viewport (target) specified by the user. When displaying the clip result in the target viewport, the same view will be set that was in the source viewport when performing the clip operation

### Command prompts:

Enter central point:

Specify the central point of the cylinder base circle.

Enter radius or [Invert]:

Specify the base radius.

To invert the clip area, select the Invert option. In this case, the area outside the cylinder will be clipped.

Select view:







Specify the target viewport, in which to display the clip. This prompt is displayed in case there are several viewports in the model space.

As a result of the  **Clip by Cylinder (inside)** command, the cloud area inside the cylinder will be clipped.

As a result of the  **Clip by Cylinder (outside)** command, the cloud area outside the cylinder will be clipped.

Only display of the cloud in the target viewport is changed as a result of the command work, the cloud object itself is not changed. Display of the cloud in other viewports remains the same.







## Clip Undo

-  Ribbon: **Point Clouds – Clip and Section** >  **Undo Clip**
-  Menu: **Point Clouds – Clip** >  **Undo**
-  Toolbar: **Point Clouds** >  **Undo clip**
-  Command line: **NPC\_CLIP\_UNDO**

You may clip the cloud repeatedly. **Clip Undo** cancels the last clip of the point cloud.

This command cancels the last clip in the specified viewport and returns the cloud display to the same view it was on the target screen when the last clip was set.

## Reset All Clips

-  Ribbon: **Point Clouds – Clip and Section** >  **Reset All Clips**
-  Menu: **Point Clouds – Clip** >  **Reset All**
-  Toolbar: **Point Clouds** >  **Reset All**
-  Command line: **NPC\_CLIP\_RESET**

It is possible to perform several successive cloud clips, including in combination with cloud sections.

This command undoes the entire sequence of cloud clips in the current viewport and displays the clouds in their original form. The display of clouds in other viewports remains the same.

## Point Clouds Section

Point clouds section is used to display needed part of the cloud. To create section, first determine the plane. UCS moves to this plane after section. Section changes only cloud mapping in specified view. Cloud section made only in one of the orthogonal views depending on the type of section.

Just as with clipping operations, as a result of the section commands, the cloud visibility changes only in the target viewport; no changes occur to the object itself. The display of cloud in other viewports remains the same.

Unlike cloud clipping operations, when creating a section, the position of the user coordinate system in the target viewport changes, which greatly simplifies the subsequent “rendering” of the resulting part of the section by constructing vector objects in the UCS plane.

## Point Clouds Unrestricted Section

 Ribbon: **Point Clouds – Clip and Section – Section** >  **Unrestricted Section**

 Menu: **Point Clouds – Section** >  **Unrestricted**

 Toolbar: **Point Clouds** >  **Unrestricted Section**

 Command line: **NPC\_SECT\_UNRESTRICTED**

Unrestricted section is performed by 3 points perpendicular to view plane. If there are several viewports in the model space, then it is necessary to specify in which viewport the section result will be displayed.

First and second points determine the vertical plane of section. Third point determines the depth of section.

### Create unrestricted section:

1. Run the command.
2. Specify the first point of section. This point will be located to the left of observer.
3. Specify the second point of vertical section. This point will be located to the right of observer.
4. Specify the depth of section.
5. Select needed view to display the section.

## Point Cloud Horizontal Section

 Ribbon: **Point Clouds – Clip and Section – Section** >  **Horizontal Section**

 Menu: **Point Clouds – Section** >  **Horizontal**

 Toolbar: **Point Clouds** >  **Horizontal section**

 Command line: **NPC\_SECT\_HORIZ**

Horizontal section is performed in **Right**, **Left**, **Front** and **Back** views and in the result view of vertical section.

Horizontal section performed by 2 points. First point determines vertical plane of section (middle elevation point). Second point determines the section.

### Create horizontal section:

1. Set **Right**, **Left**, **Front** or **Back** view or the result view of vertical section.
2. Run **Horizontal section**.
3. Specify the middle elevation point of section.
4. Specify the depth of section.
5. Select needed view to display the section.

## Point Cloud Vertical Section

 Ribbon: **Point Clouds – Clip and Section – Section >**  **Vertical Section**

 Menu: **Point Clouds – Section >**  **Cut**

 Toolbar: **Point Clouds >**  **Vertical Section**

 Command line: **NPC\_SECT\_CUT**

Vertical section is similar to vertical section in **Right, Left, Front, Back** view or the result view of vertical section. Section plane is perpendicular to the current view plane.

Vertical section performed by 2 points. First point determines vertical plane for section. Second point determines the section depth.

### Create cut section:

1. Set **Right, Left, Front, Back** view or the result view of vertical section. Section plane is perpendicular to the current view plane.
2. Run the **Vertical Section** command.
3. Specify cut position in section view.
4. Specify section depth. This point determines the observer position in result view.
5. Select required view to display the section.

## Clip Invert

 Ribbon: **Point Clouds – Clip and Section >**  **Clip Invert**

 Menu: **Point Clouds – Clip >**  **Invert**

 Toolbar: **Point Clouds >**  **Clip Invert**

 Command line: **NPC\_CLIP\_INVERT**

The command hides all visible cloud points and displays all points hidden as a result of clipping or sectioning. Applies to the active viewport.

## Copying a Clip to the Selected View

 Ribbon: **Point Clouds – Clip and Section >**  **Copying a Clip to the Selected View**

 Menu: **Point Clouds > Clip >**  **Copying a Clip to the Selected View**

 Command line: **NPC\_CLIP\_CLONE**

The command clips the point cloud of the current model space viewport, similar to clipping a cloud in the specified viewport.

### To copy a cloud clipping from another viewport:

1. Go to the model space viewport in which the cloud is to be clipped.

2. Run the command. The prompt will appear in the command line:

Select view to clone:

3. Click the model space viewport containing the clipping you want to copy.
4. The cloud in the original viewport is clipped identically to the cloud in the selected one.

## Isolate Features

The commands for managing features apply to point clouds in which geometric features have been previously found: pipelines, pipeline elements, planes, and plane elements.



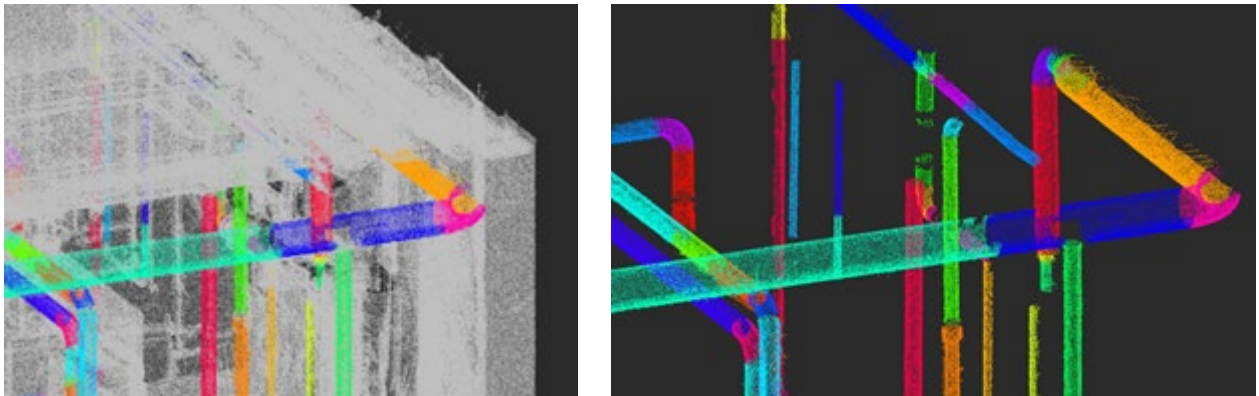

The commands are used to create a temporary view when it is necessary to hide the selected features, or to isolate - to leave only the selected features visible, while hiding all others.

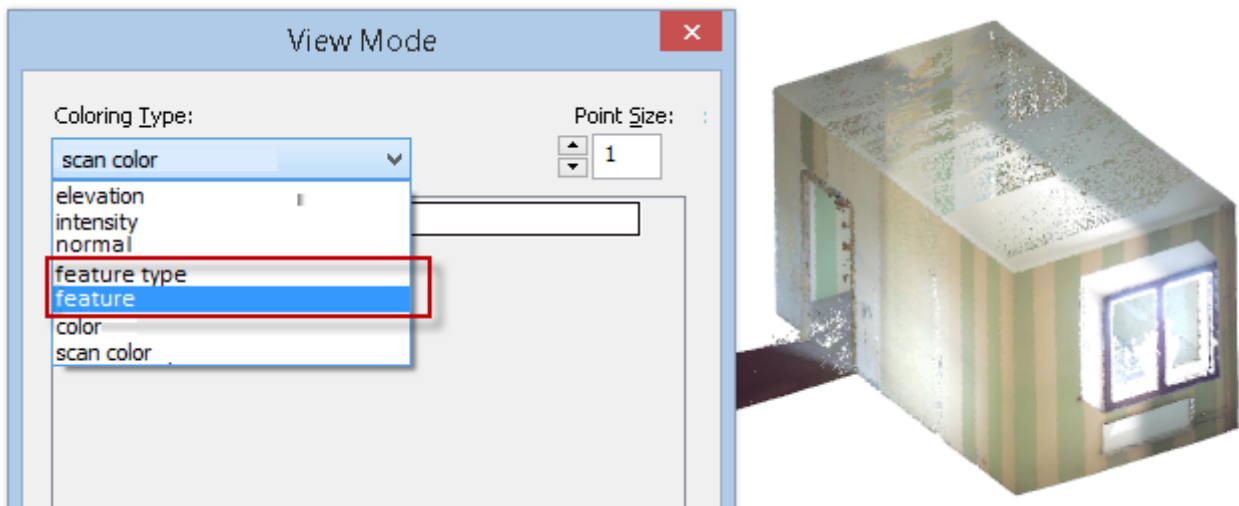





You can identify the presence of features in a cloud in the **View mode** window – for clouds with recognized features, the Feature and Feature type coloring types will be available.



The feature isolation commands work with any type of cloud coloring, but coloring by features makes the work with commands the most visible.







-   **Hide Feature** – hides the display of the specified features.
-   **Hide All Features** – hides the display of all features, leaving unrecognized parts of the cloud visible.



- 
**Isolate Feature** – keeps the feature selected for isolation visible, hiding the rest of the cloud.
- 
**Isolate All Features** – leaves all features displayed, hiding unrecognized parts of the cloud. If any cloud features have been hidden, their display is restored.
- 
**Show All Features** – if at least one cloud feature was hidden, the command restores the display of all features without changing the display status of the unrecognized part of the cloud. If all cloud features were displayed, the command hides the unrecognized part of the cloud.
- 
**Feature Isolation Reset** – resets features isolation, showing all parts of the cloud.

**NOTE:** Isolation of features, in contrast to the isolation of objects, is carried out within the framework of the general mechanism of cancellation-return of actions (UNDO/REDO).

## Hiding a Feature





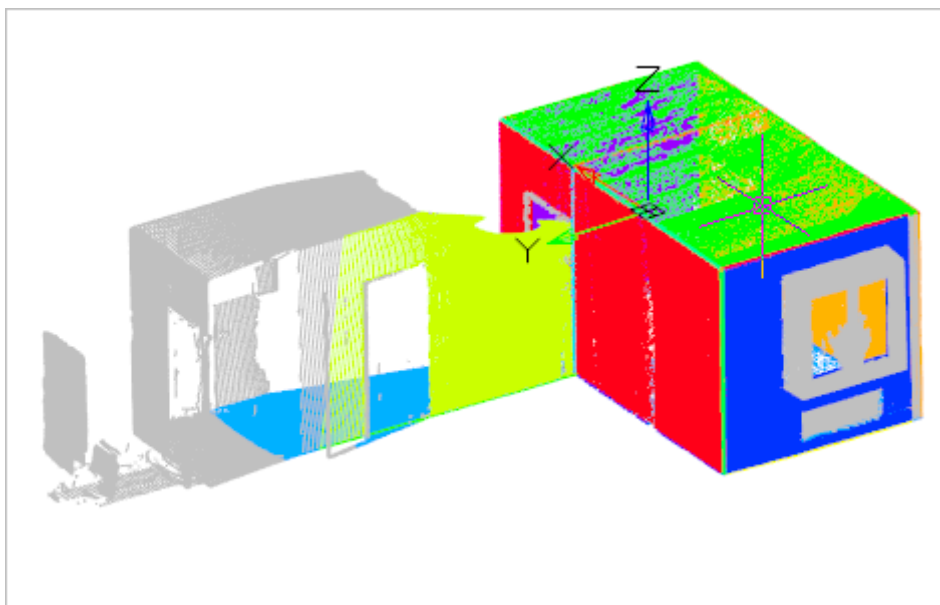

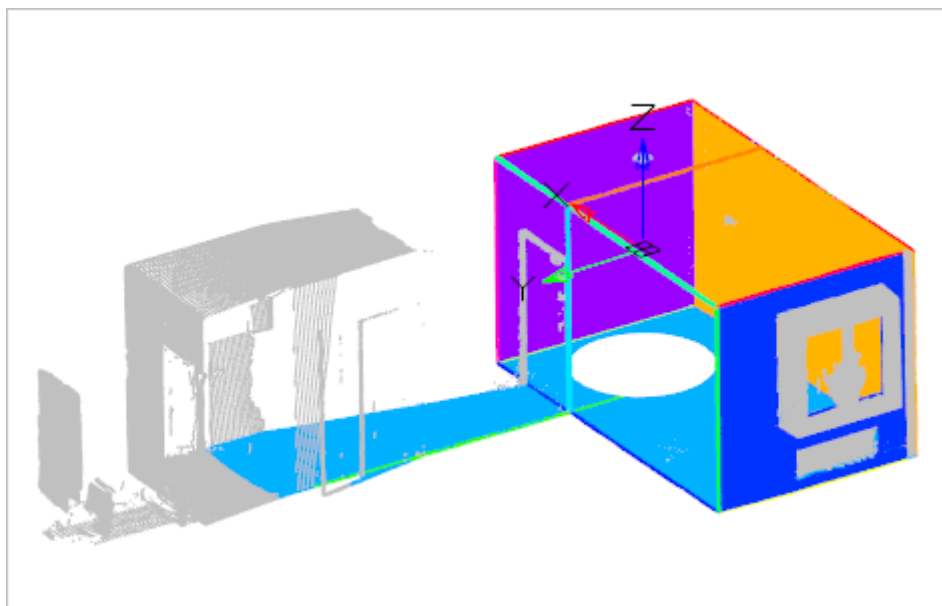
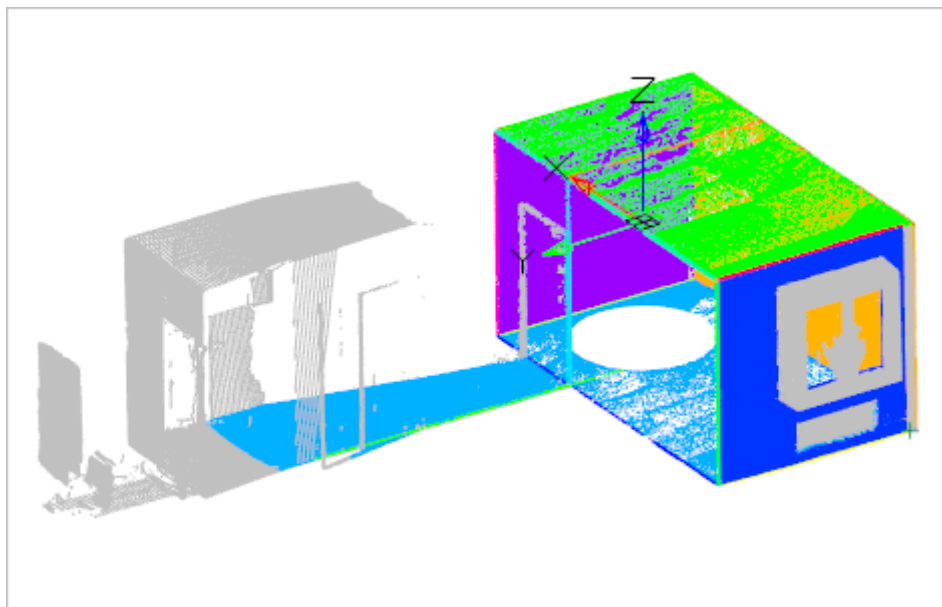
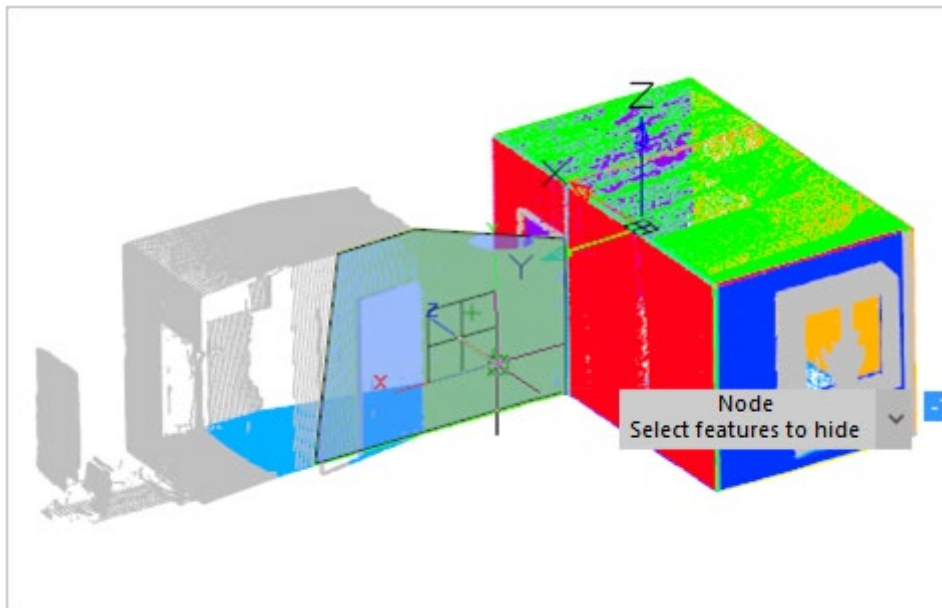
-  Ribbon: **Point Clouds – Managing Features** >  **Hide Feature**
-  Menu: **Point clouds – Managing Features** >  **Hide Feature**
-  Toolbar: **Point clouds** >  **Hide Feature**
-  Command line: **NPC\_HIDE\_FEATURE**

The command allows you to hide the display of specified features.







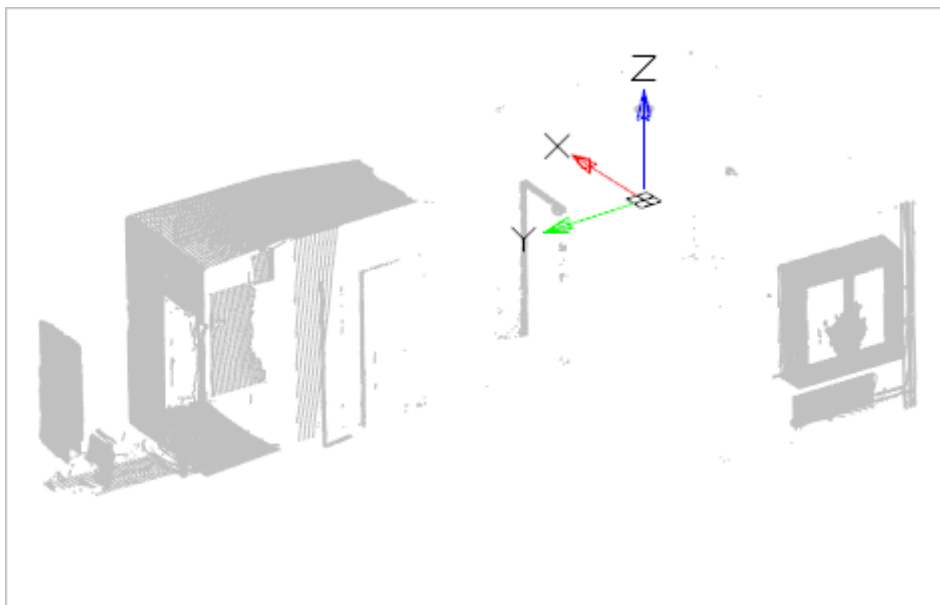
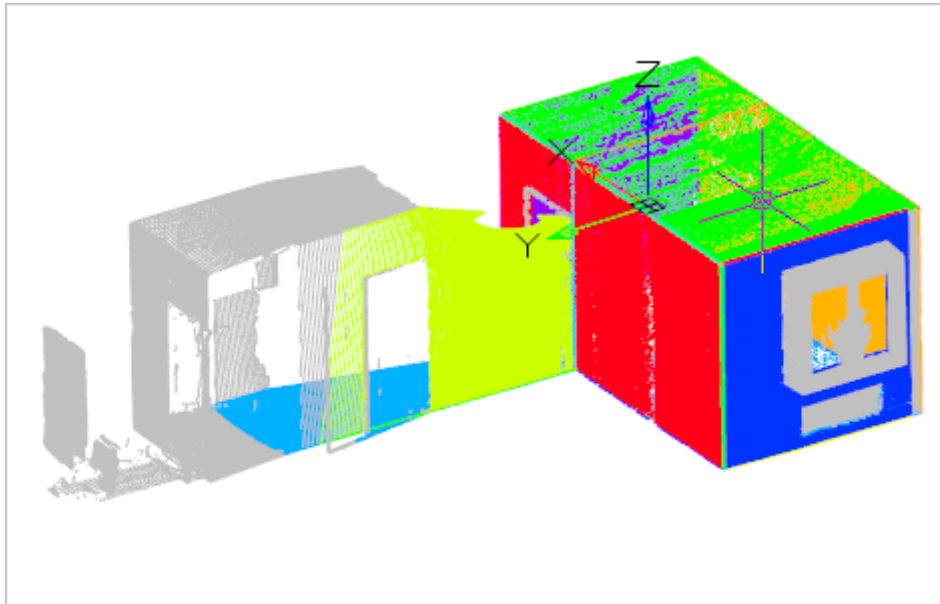

## Hiding All Features

-  Ribbon: **Point Clouds – Managing Features** >  **Hide All Features**
-  Menu: **Point clouds – Managing Features** >  **Hide All Features**
-  Toolbar: **Point clouds** >  **Hide All Features**
-  Command line: **NPC\_HIDE\_ALL\_FEATURES**

The command hides the display of all features, leaving unrecognized parts of the cloud visible.



## Isolating a Feature

-  Ribbon: **Point Clouds – Managing Features** >  **Isolate Feature**
-  Menu: **Point clouds – Managing Features** >  **Isolate Feature**

 Toolbar: **Point clouds** >  **Isolate Feature**

 Command line: **NPC\_ISOLATE\_FEATURE**

The command leaves the feature selected for isolation visible, hiding the rest of the cloud.

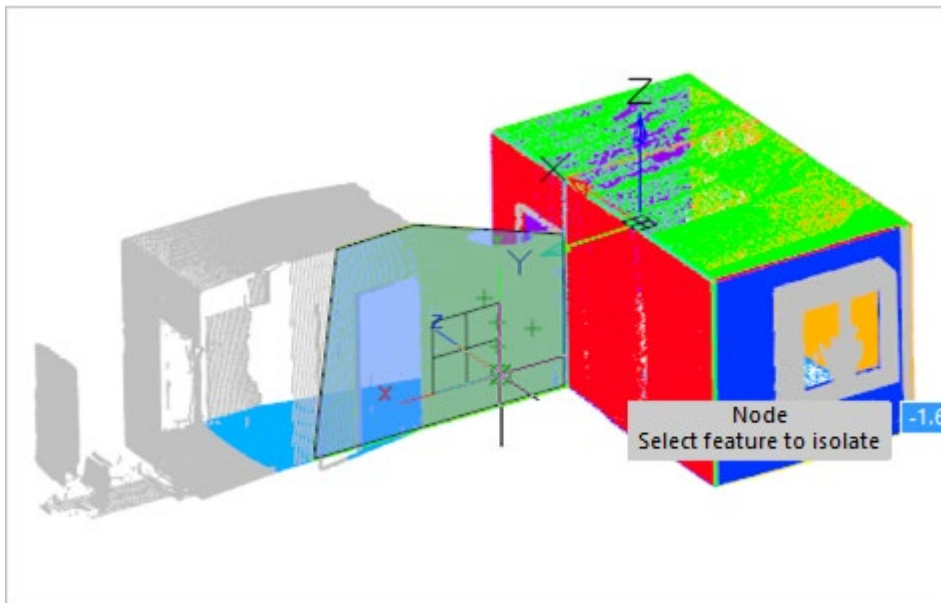
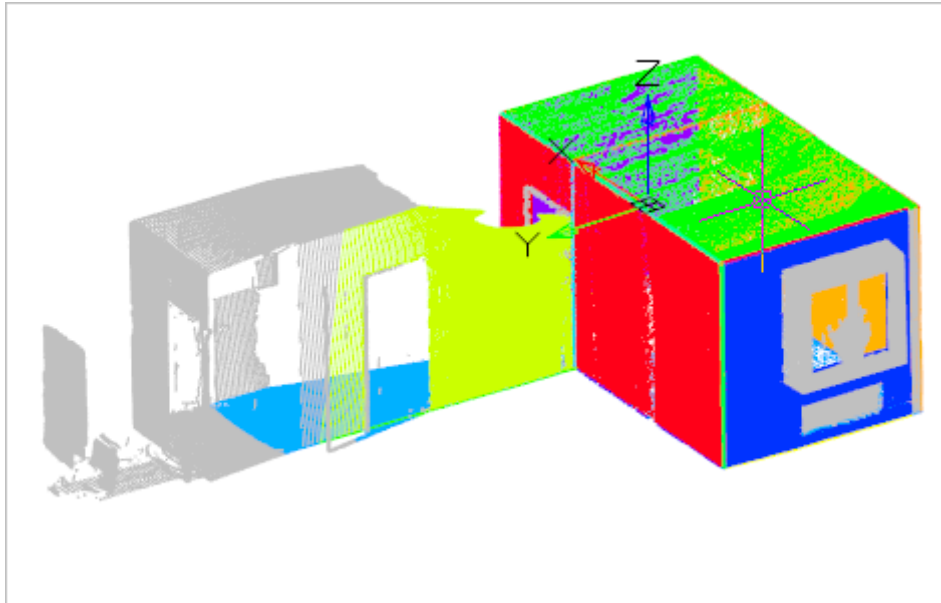

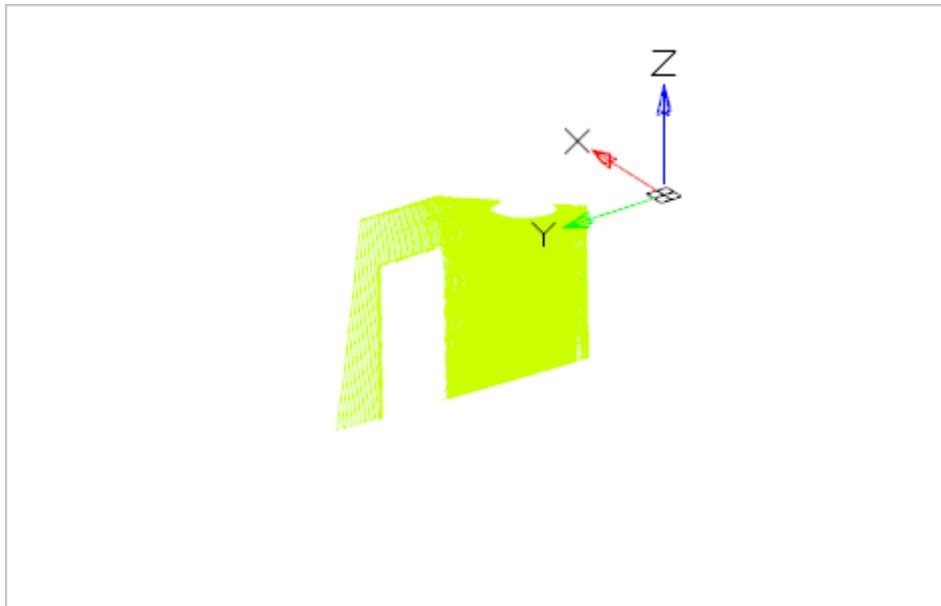

## Isolating All Features

 Ribbon: **Point Clouds – Managing Features** >  **Isolate All Features**

 Menu: **Point clouds – Managing Features** >  **Isolate All Features**

 Toolbar: **Point clouds** >  **Isolate All Features**





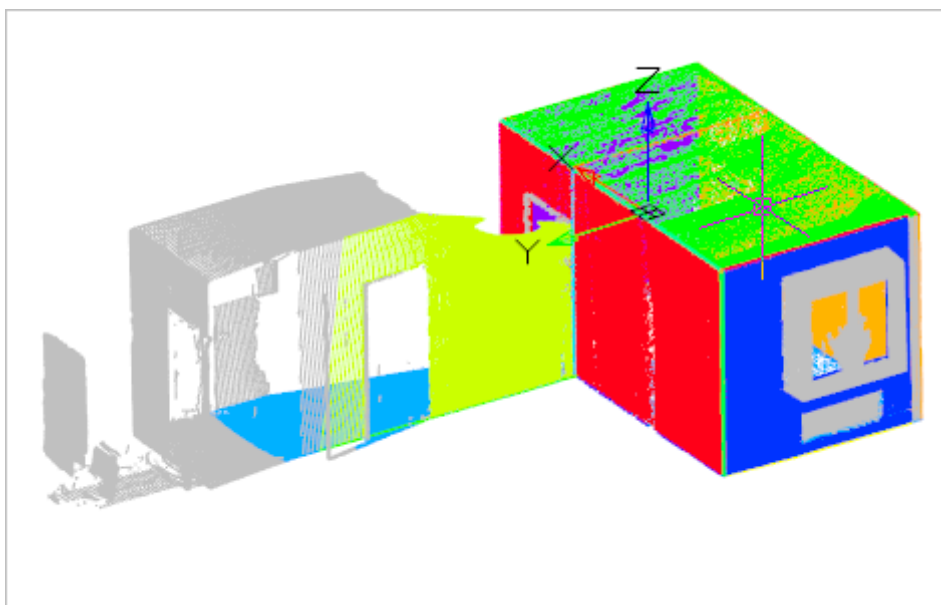

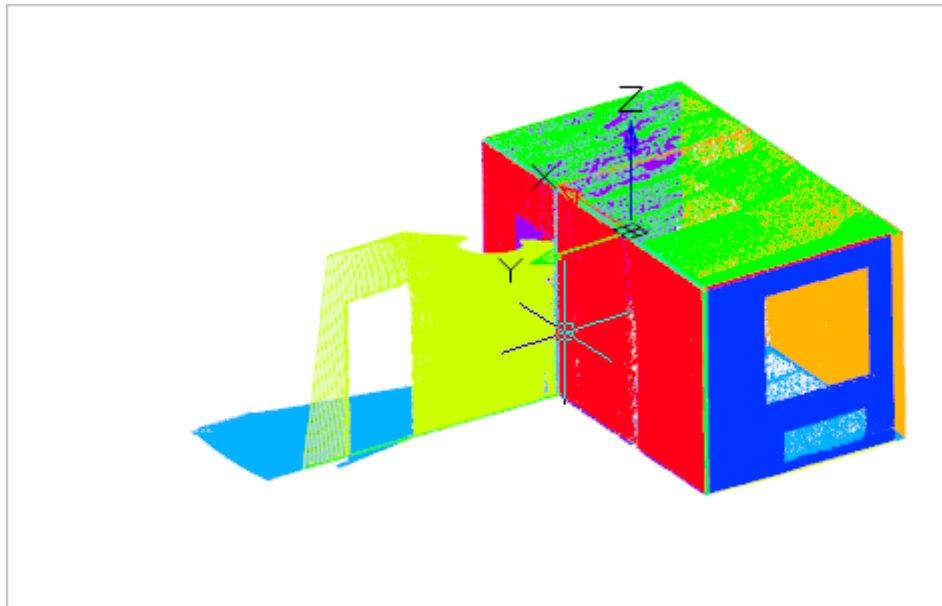
 Command line: **NPC\_ISOLATE\_ALL\_FEATURES**

The command displays all features, hiding unrecognized parts of the cloud. If any cloud features have been hidden, their display is restored.





## Showing All Features

-  Ribbon: **Point Clouds – Managing Features** >  **Show All Features**
-  Menu: **Point clouds – Managing Features** >  **Show All Features**
-  Toolbar: **Point clouds** >  **Show All Features**
-  Command line: **NPC\_SHOW\_ALL\_FEATURES**

If at least one cloud feature was hidden, the command restores the display of all features without changing the display status of the unrecognized part of the cloud.

If all cloud features were displayed, the command hides the unrecognized part of the cloud.

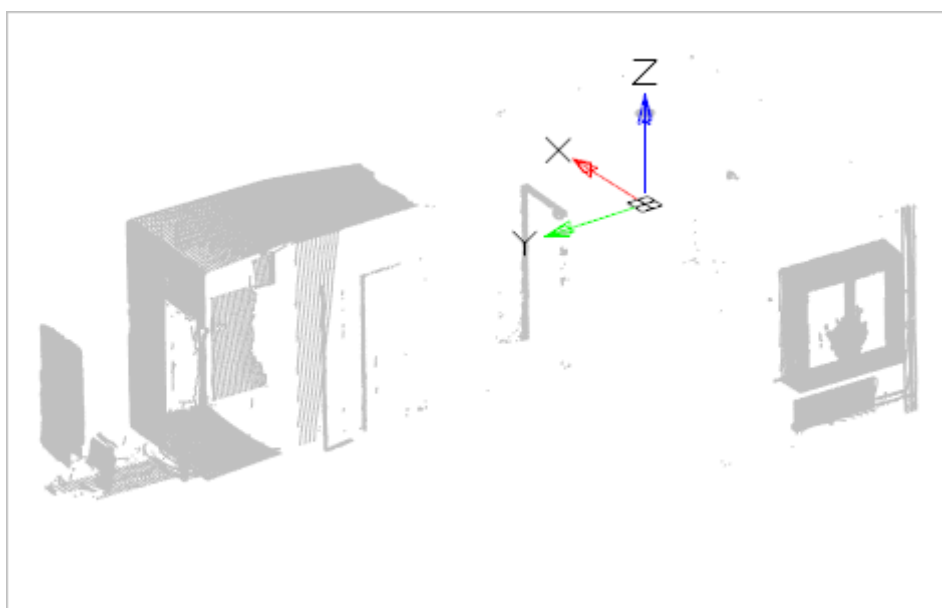

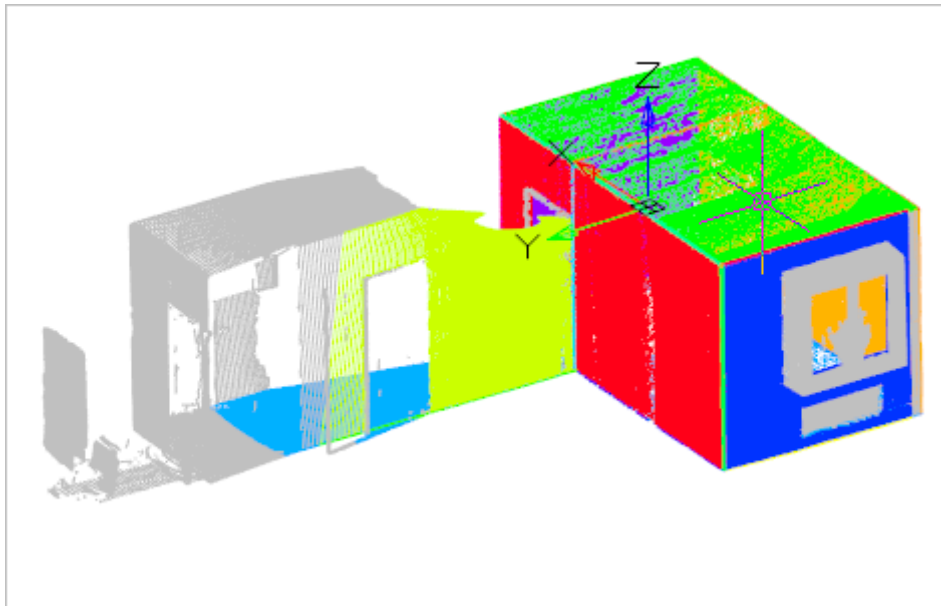

## *Feature Isolation Reset*

 Ribbon: **Point Clouds – Managing Features** >  **Feature Isolation Reset**

 Menu: **Point clouds – Managing Features** >  **Feature Isolation Reset**

 Toolbar: **Point clouds** >  **Feature Isolation Reset** **Feature Isolation Reset**

 Command line: **NPC\_UNISOLATE\_ALL\_FEATURES**

The command resets the features isolation, showing all parts of the cloud.

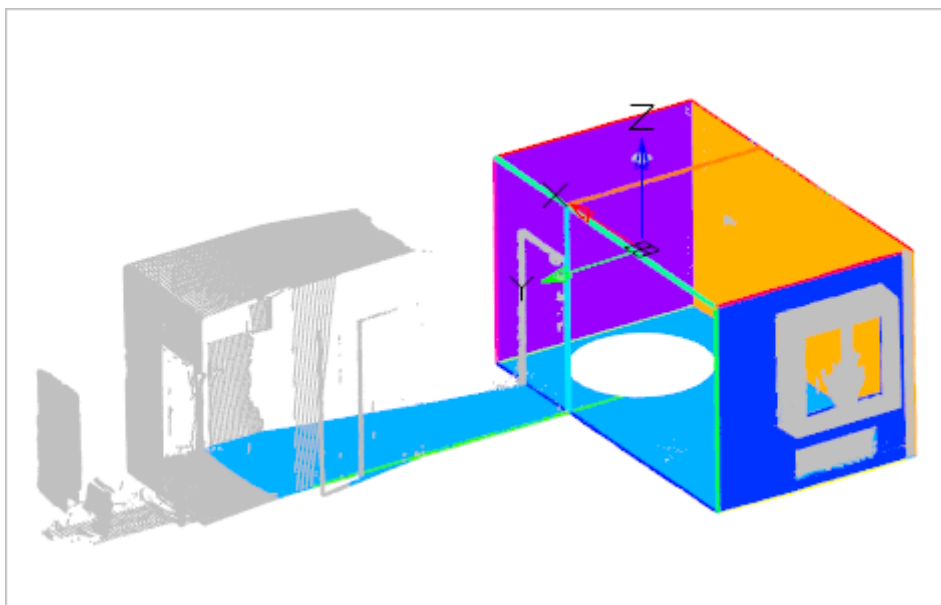

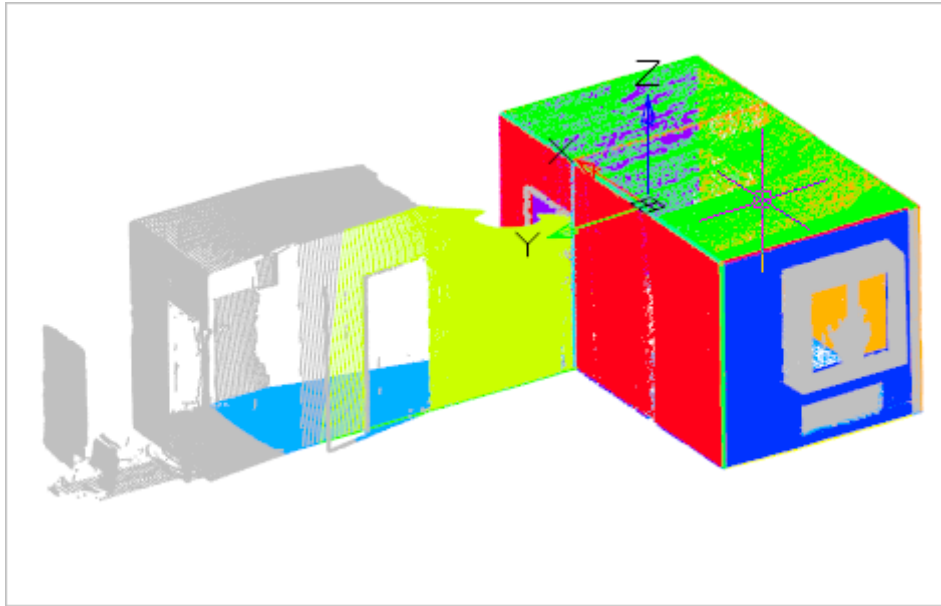

## Information

Get info about selected point cloud or specific point. **Properties** toolbar shows some info.

## Point Cloud Comparison Widget

### Enabling the Point Cloud Comparison Widget

Enables a widget that displays the results of commands in the form of a deviation distribution chart in the right side of the viewport.

 **Enabling the Point Cloud Comparison Widget.**

 Ribbon: **Point Clouds – Information** >  **Enabling the Point Cloud Comparison Widget**

 Menu: **Point Clouds – Information** >  **Enabling the Point Cloud Comparison Widget**

 Toolbar: **Settings and Information** >  **Enabling the Point Cloud Comparison Widget**

 Command line: **NPC\_COMPARE\_LEGEND\_ON**



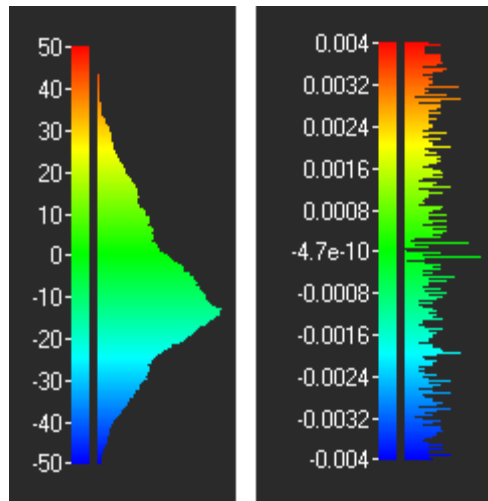

A similar diagram of the distribution of deviations can be viewed in the **View Mode** dialog for the **Deviation value** coloring type.

## Disabling the Point Cloud Comparison Widget

The widget can be disabled by the **NPC\_COMPARE\_LEGEND\_OFF** command



**Disabling the Point Cloud Comparison Widget.**



Ribbon: **Point Clouds – Information** >  **Disabling the Point Cloud Comparison Widget**



Menu: **Point Clouds – Information** >  **Disabling the Point Cloud Comparison Widget**



Toolbar: **Settings and Information** >  **Disabling the Point Cloud Comparison Widget**



Command line: **NPC\_COMPARE\_LEGEND\_OFF**

## Point Cloud Info



Ribbon: **Point Clouds – Calculations and Info** >  **Point Cloud Info**



Menu: **Point Clouds – Calculations and Info** >  **About Cloud**



Toolbar: **Point Clouds** >  **Point Cloud Info**



**Properties** toolbar – **Misc** – **Point cloud info** >  button





Command line: **NPC\_INFO**

Displays statistic information about point cloud and excludes/includes certain point cloud attributes.

## Statistics

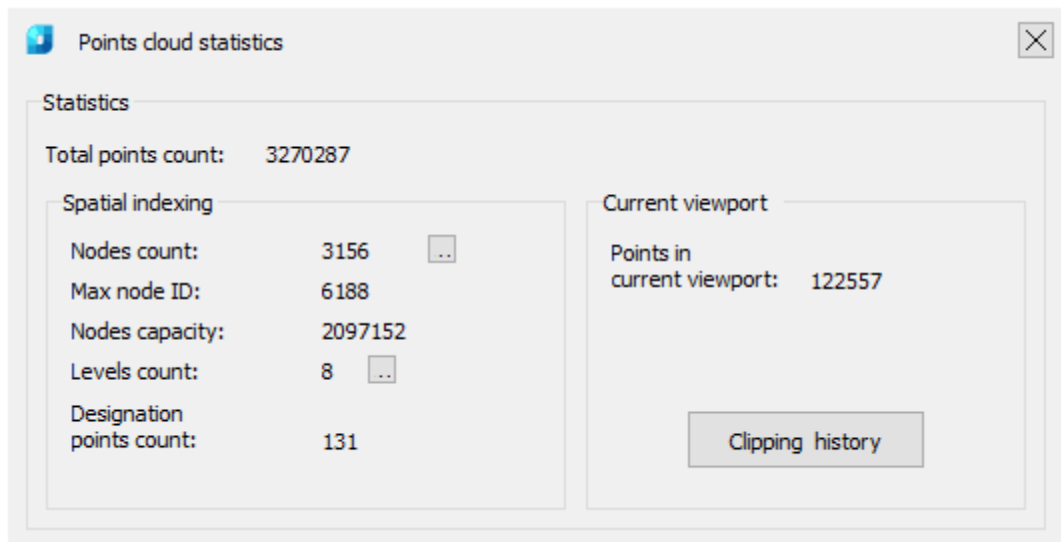
**Statistics** displays the number of cloud points, nodes and levels in the point cloud structure tree, their maximum and designation.



The  button next to the **Nodes count** option opens a diagram of the distribution of points by nodes of the cloud tree.

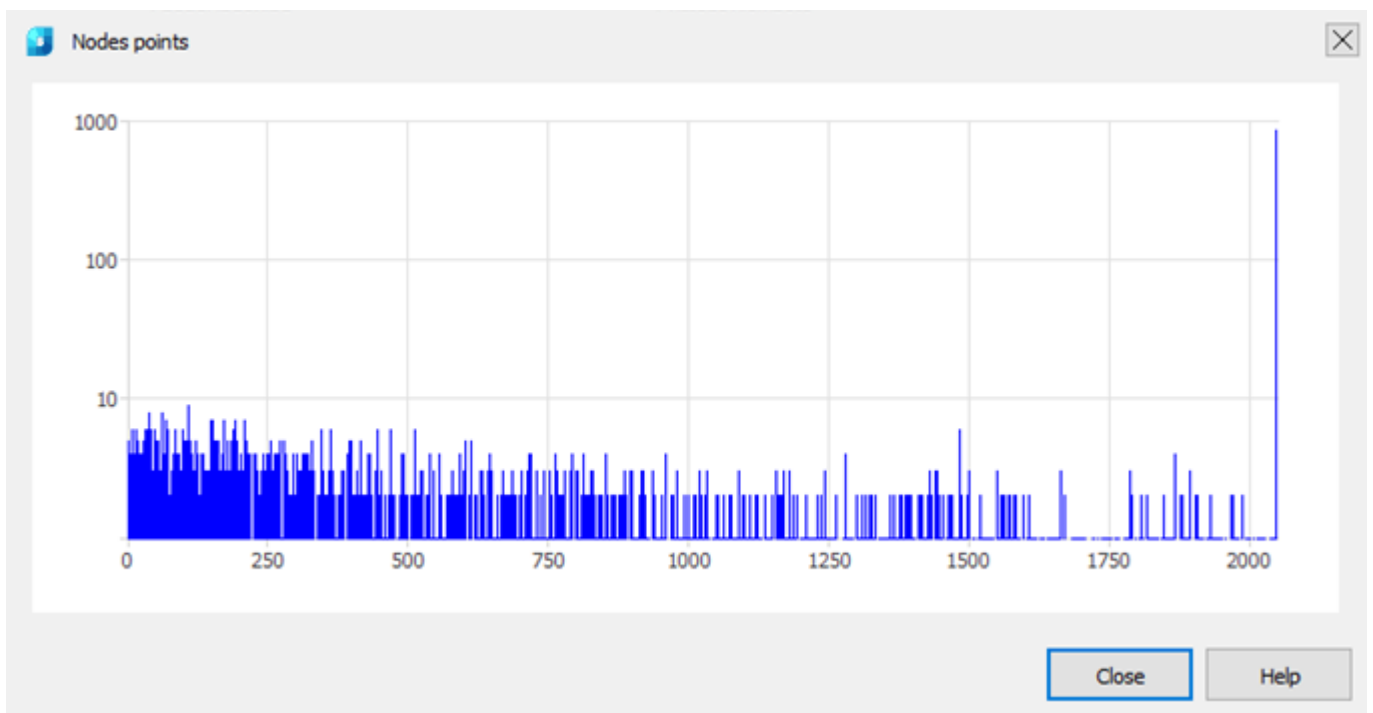

A diagram of the distribution of nodes (vertical diagram) by levels of the structured cloud tree (horizontal diagram) can be viewed by clicking the  button next to the **Levels count** option. By moving the right or left borders on the distribution diagram, you can cut off the display of cloud points belonging to certain levels of the hierarchical structure. On the drawing, such points will disappear.

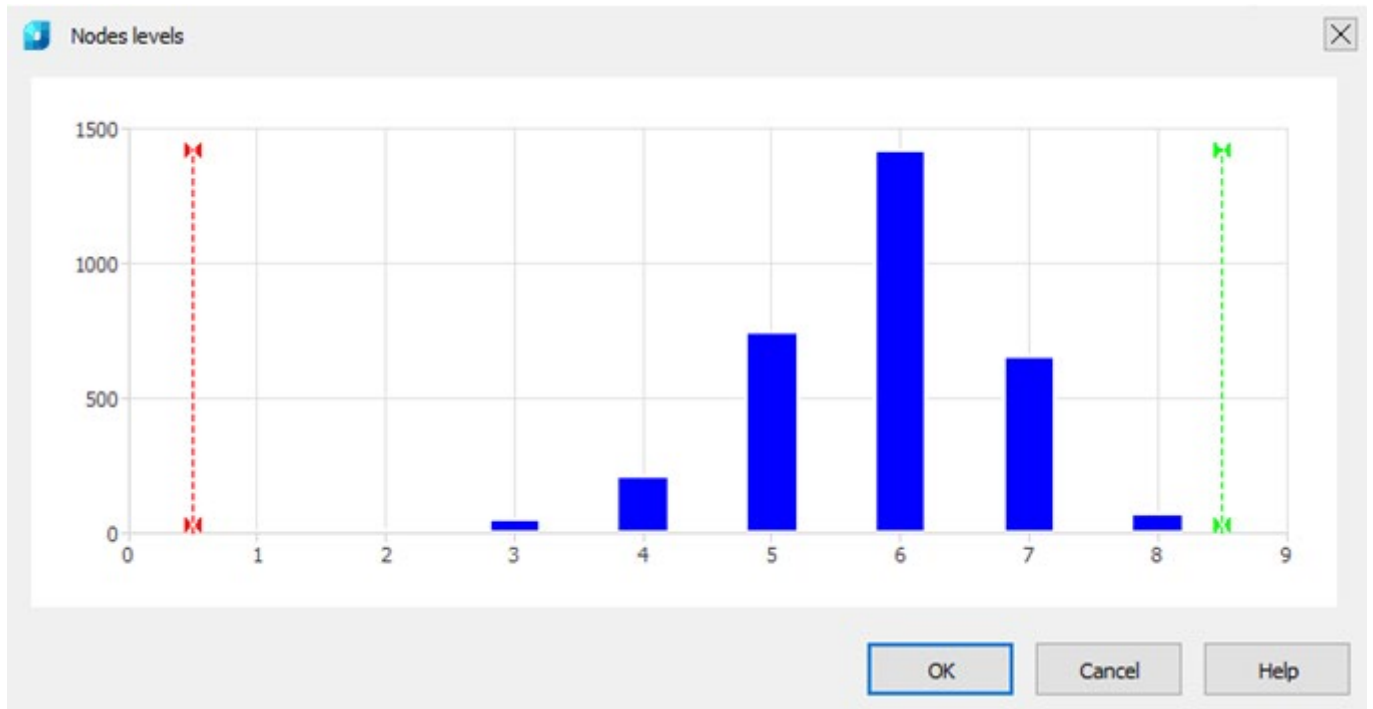

The **Points in current viewport** parameter shows how many cloud points are actually displayed in the current view, including all clippings and sections. The history of clippings and sections of the point cloud can be viewed by clicking the **Clipping history** button.

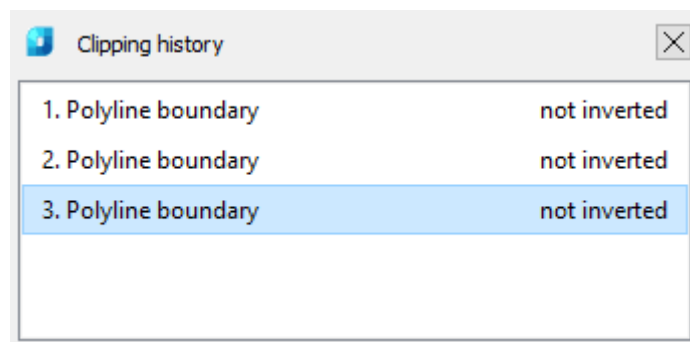



Clipping history	
1. Polyline boundary	not inverted
2. Polyline boundary	not inverted
3. Polyline boundary	not inverted

## Cloud Attributes

The **Storage structure** section displays information on the presence or absence of certain attributes of points of the cloud imported into a document.

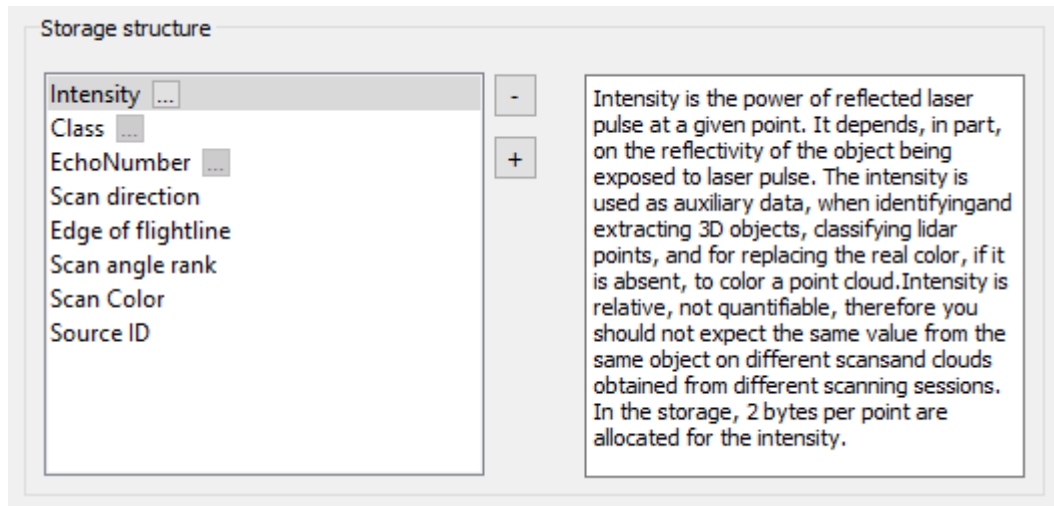
The list contains a list of existing cloud point attributes. The window on the right displays a description of the selected attribute.



The  button unloads (deletes) the selected attribute from the cloud. This removes all information on this attribute from the point cloud in the document. After unloading, the possibility to carry out operations using the unloaded attributes, including coloring the point cloud by this attribute, is lost.

**NOTE:** Attributes unloaded only from the current document. External file with point cloud is unchanged.

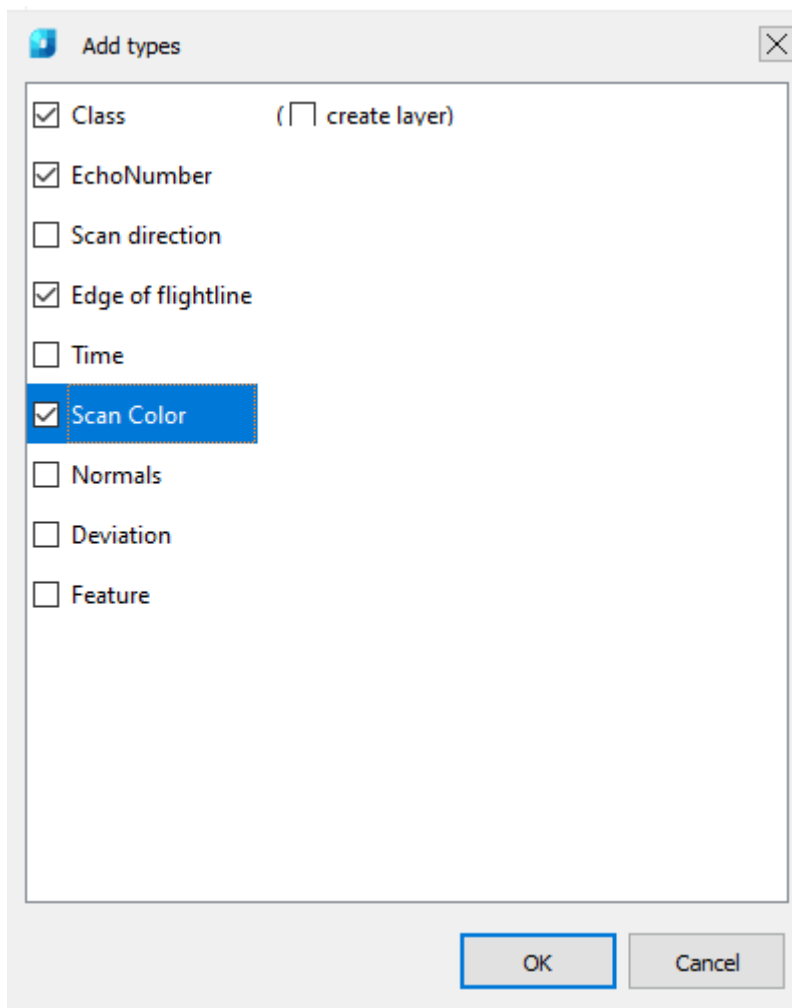

It is possible to add missing attributes with the  button and then select them from the list in the **Add types** dialog.

However, it should be understood that newly created attributes do not carry any values.

So, unloading such an attribute as **Intensity** from the cloud will lead to a complete loss of intensity values for the points of this cloud in the document.

If this attribute is later added with the  button, the intensity values will not be restored.

If originally the cloud did not have **Class** attribute, enabling the **create layer** box will automatically create a new layer with the name **Created, never classified (code 0)** and assign class **0** to all cloud points

Name	Color	Linetype	Linewe	Transp	Plot Styl	Descrij
0	white			0	Color_7	
Created (never classified) (code 0)	image...			0	Color_6	FC#0
Point Cloud	white			0	Color_7	

The  button next to some attributes allows you to view the diagram of the distribution of the values of this attribute. This is possible for such attributes as **Intensity**, **Class** and **Echo number**. If there are no attribute values, the chart is not displayed.

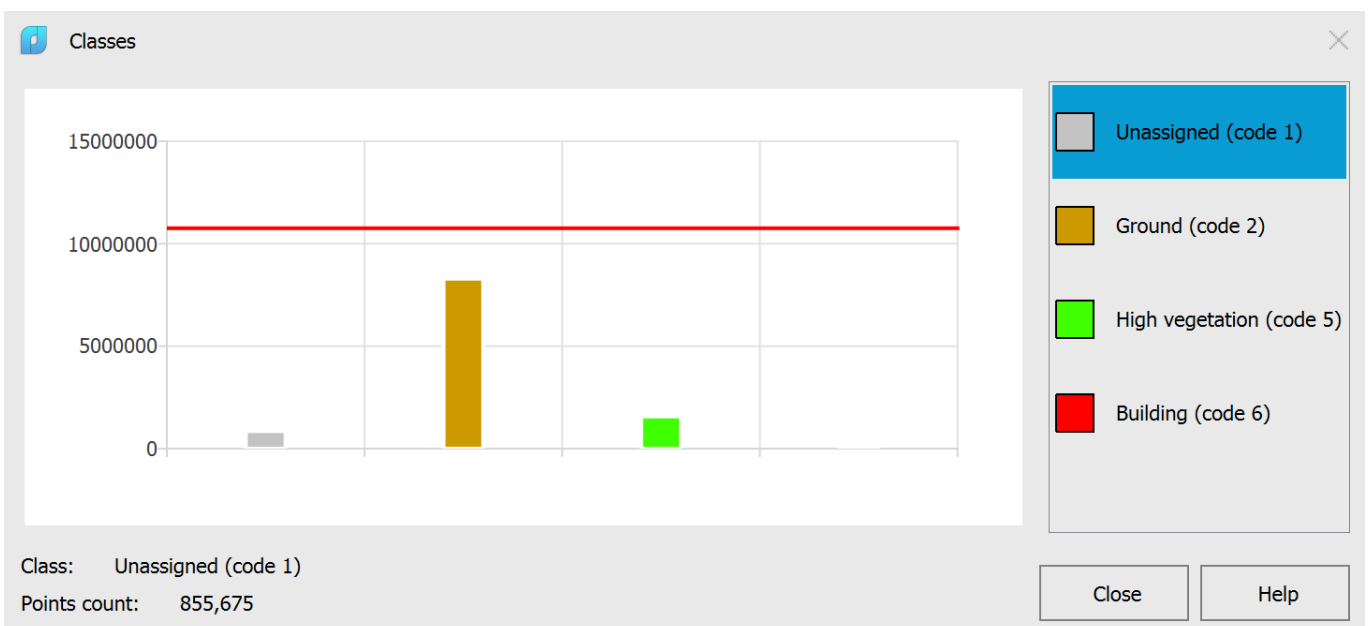
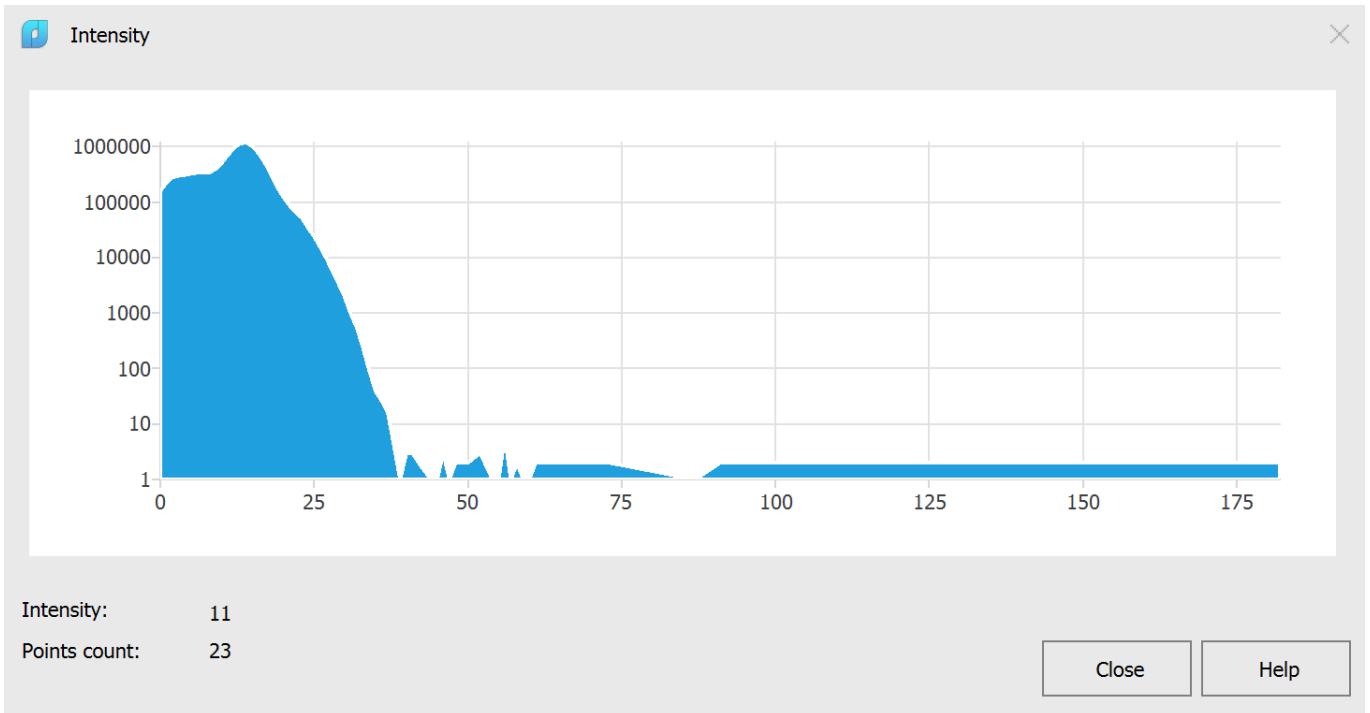

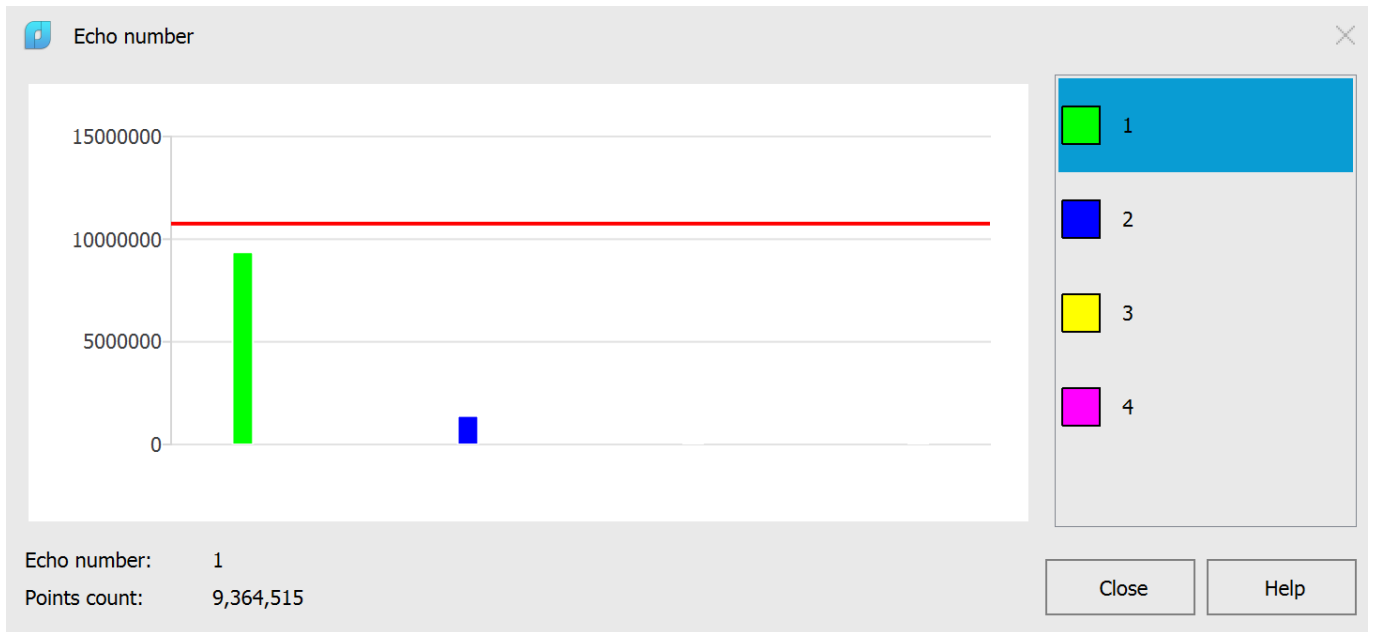

## Geoinformation



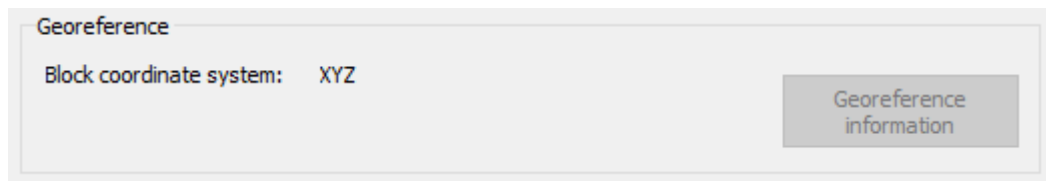

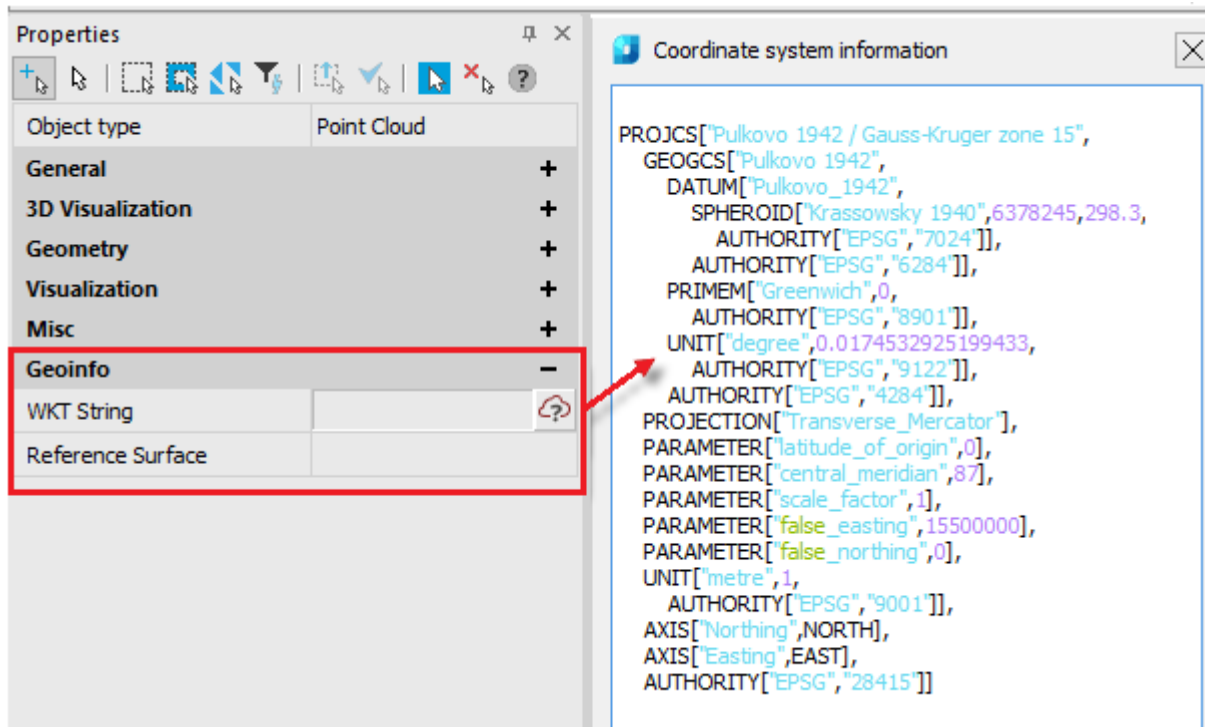

Point clouds imported from some types of formats (LAS, LAZ) can be geo-referenced. In the **Georeference** section, by clicking the **Georeference information** button, you can view detailed information about the coordinate system and georeference of the cloud.



The same information for the cloud selected in the workspace can be viewed in the **Properties** bar in the **Geoinfo** section.



## Point Info

-  Ribbon: **Point Clouds – Calculations and Info** >  **Point Info**
-  Menu: **Point Clouds – Calculations and Info** >  **About Point**
-  Toolbar: **Point Clouds** >  **Point Info**
-  Command line: **NPC\_POINT\_INFO**

Point info displays information about point in the **Properties** bar. When running the command, the cursor changes to a cross and the **Node** snap symbol appears.

Parameters	
point cloud file name	C:\Users\Inz20\AppData\Ro...
index	11 333 637
x	-2.4039
y	3.8259
z	-1.7927
intensity	18 913
source ID	7
color	(22,29,23)

If there are recognized geometric features in the cloud, it is possible to view the geometric parameters of these features, as well as manage their visibility – isolate or disable their display.

Parameters	
file name	G:\Temp\Data\PointClouds\...
index	367 804 416
x	12877.3240
y	.4420.4385
z	3320.2066
nx	0.1903
ny	-0.3425
nz	0.9200
intensity	944
feature	Cylinder,2 
Radius	139.3363
Surface tolerance	10.0000

To isolate or hide a feature, click the **Feature** option in the **Properties** bar. Two buttons will appear.

 **Hide Feature**

Allows you to hide the feature whose point was selected in the **Point Information** command. The result is similar to that of the **Hide Feature** command.

 **Isolate feature**

Allows you to hide the feature whose point was selected in the **Point Information** command. The result is similar to that of the **Isolate Feature** command.

## Determining the Radius



Ribbon: **Point Clouds – Information** >  **Determining the Radius**



Menu: **Point clouds – Information** >  **Determining the Radius**



Toolbar: **Point clouds** >  **Determining the Radius**



Command line: **\_NPC\_RADIUS**

The command for determining the radius allows you to get data on the radius of pipes and cylinders recognized in the point cloud in a form that allows you to transfer this information to other commands in the nanoCAD environment. The command is “transparent” and can be launched over an already running command. For example, the task is to draw a circle centered on the axis of a recognized pipe and with the radius of this pipe. To solve this problem, you can set up a **3D snap** on the axis of the recognized geometry. Run the command to draw a circle by center and radius. Select the center point of the circle, the circle drawing command will ask for the radius. After that, without exiting the circle drawing command, run the radius determination command. Select the point of the pipe on the axis of which we have chosen the center of the circle. The command for determining the radius is completed and fills in the command line request to set the radius with the value of the pipe recognized in the cloud. The second scenario for using the command for determining the radius involves its isolated call. By calling the radius determination command, we can fill the clipboard with the radius of the pipe or cylinder we are interested in. This feature will allow you to interact with commands whose parameters are set through modal dialogs. Having remembered the radius value in the clipboard, when calling such a command, we can fill in the required field in the dialog with the radius value.



## Determining the Diameter

 Ribbon: **Point Clouds – Information** >  **Determining the Diameter**

 Menu: **Point clouds – Information** >  **Determining the Diameter**

 Toolbar: **Point clouds** >  **Determining the Diameter**

 Command line: **\_NPC\_DIAMETER**

The command for detecting the diameter allows you to obtain data on the diameter of pipes and cylinders recognized in the point cloud in a form that allows you to transfer this information to other commands in the nanoCAD environment. The command is “transparent” and can be launched over an already running command. For example, the task is to draw a circle centered on the axis of a recognized pipe and with the diameter of this pipe. To solve this problem, you can set up a **3D snap** on the axis of the recognized geometry. Run the command to draw a circle by center and diameter. Select the center point of the circle, the circle drawing command will ask for the diameter. After that, without exiting the circle drawing command, run the diameter determination command. Select the point of the pipe, on the axis of which we have selected the circle center. The command for determining the diameter is completed and fills in the command line request to specify the diameter with the value of the pipe recognized in the cloud. The second scenario for using the command to determine the diameter involves its isolated call. By calling the command to determine the diameter, we can fill in the clipboard with the diameter of the pipe or cylinder we are interested in. This feature will allow you to interact with commands whose parameters are set through modal dialogs. Having remembered the diameter value in the clipboard, when calling such a command, we can fill in the required field in the dialog with the diameter value.

# TOPOPLAN MODULE



The **Topoplan** module is available only for 64-bit version.

The **Topoplan** module is designed to create a digital terrain model and prepare a drawing for the release of topographic plans.

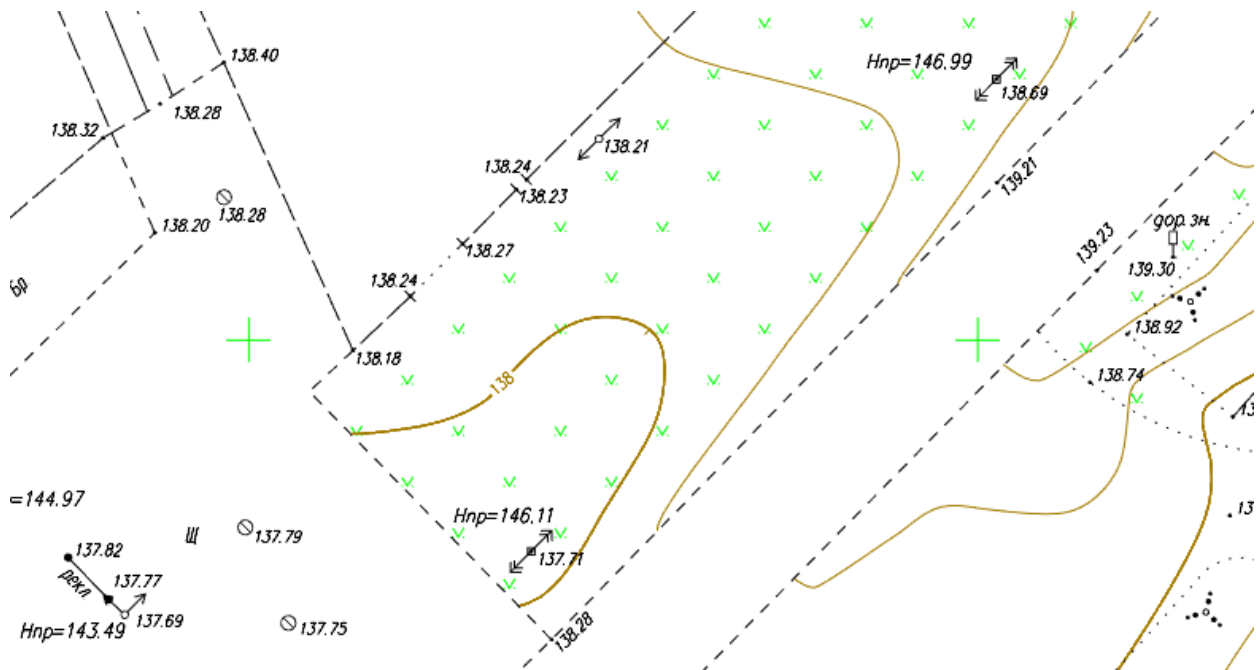

The commands are collected in the **Topoplan** ribbon tab (and **Topoplan** menu of the classic interface).

**NOTE:** If there is no license for the module, when the commands start a warning message will appear that the commands will not work.

To work, use the meter template **nanoCAD\_EarthWork\_metric.dwt** from the list of platform templates.

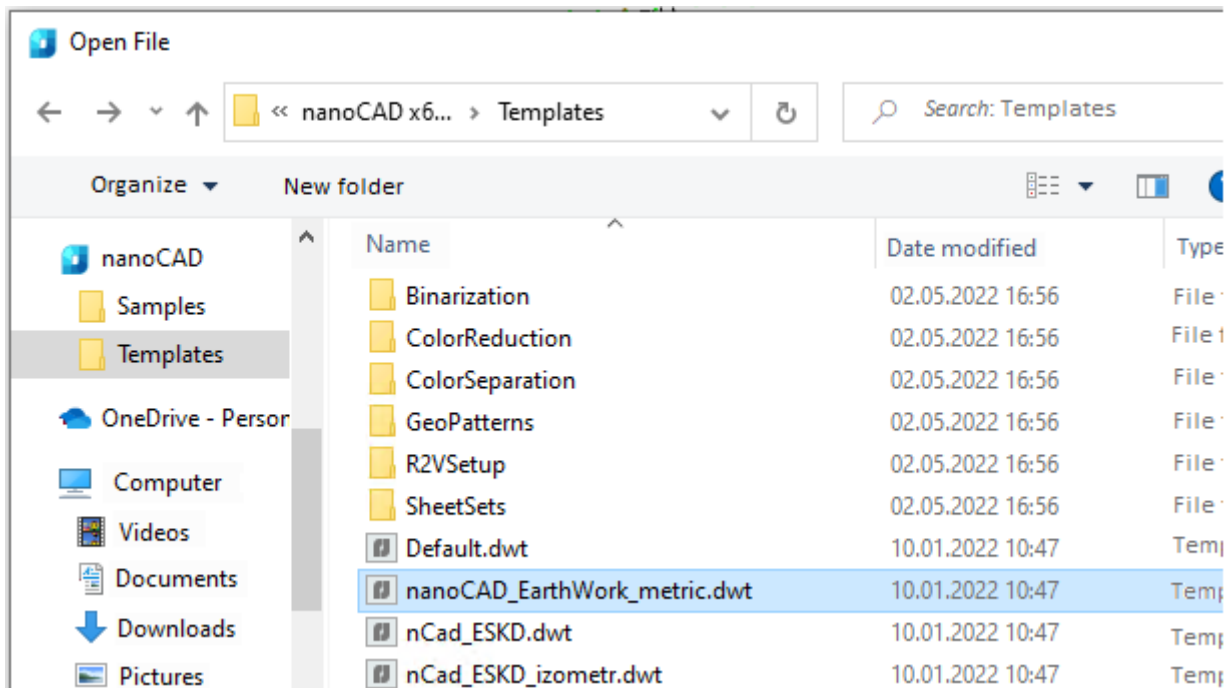

The **Topoplan** module includes support of Civil 3D objects. If you open a drawing containing such objects, then they will be displayed as drawing objects (and not as proxy graphics), display of their properties (for example, on the **Properties** bar), switching styles, and managing style elements for some objects will be available.

### Displaying command settings in the Properties bar

Settings of most module commands are displayed and edited on the **Properties** bar.

If the **Properties** toolbar was not open (for example, by **CTRL+I**), it will be displayed automatically.

At this time, the prompt is displayed in the command line:

```



Select objects or [?]:
1 found
Select objects or [?]:
1 suitable.
Apply changes [Yes/No/Save/saveDefault] <Yes>:

```

Change the settings, if necessary, and continue to perform the command by pressing **ENTER** or selecting **Yes** in the command line.

If the display of dialog boxes has been disabled by CMDDIA variable, the command options will be output one by one to the command line.

## New Topoplan

-  Ribbon: **Topoplan – Settings** >  **New Topoplan**
-  Menu: **Topoplan – Settings** >  **New Plan**
-  Toolbar: **Topoplan Settings** >  **New Plan**
-  Command line: **NEW\_PLAN**



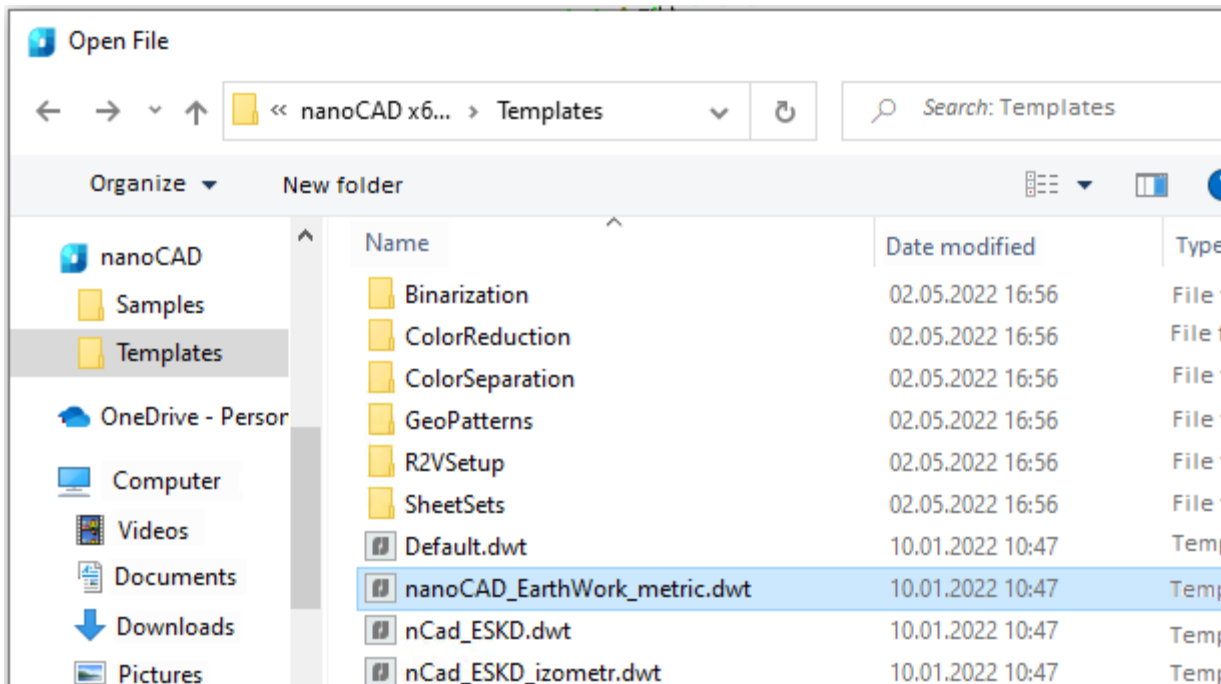

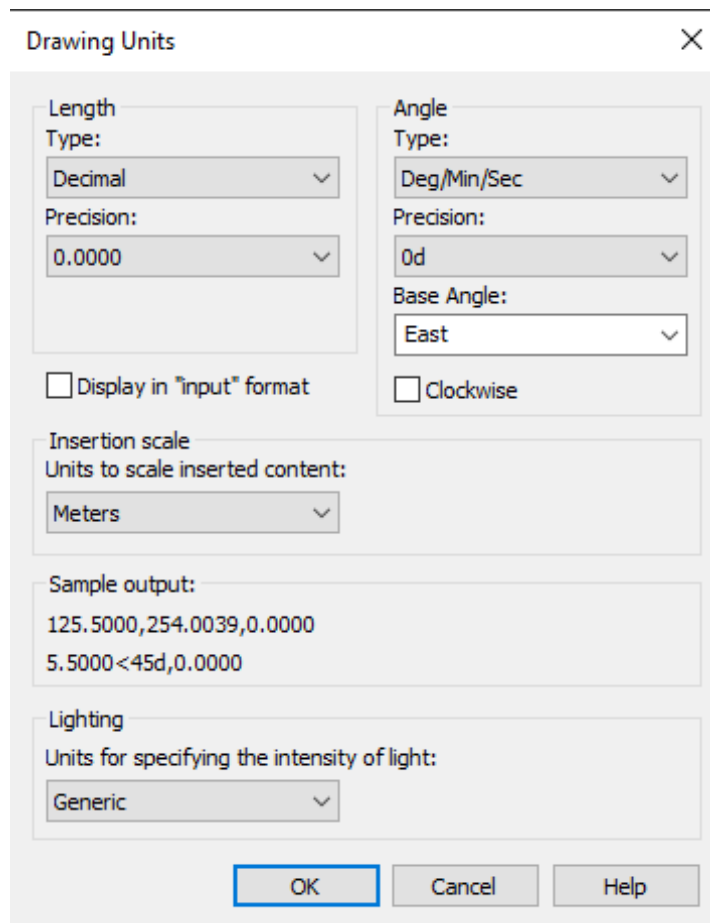

The **New Topoplan** command creates a new document with a pre-configured nanoCAD\_EarthWork\_metric.dwt template for the Topoplan module. The template is stored in the **Templates** folder.



The linear units of the new drawing are meters, the angular units are degrees/minutes/seconds.



## Recalculation of Coordinates by EPSG Codes

-  Ribbon: **Topoplan – Settings** >  **Recalculation of Coordinates**
-  Menu: **Topoplan – Settings** >  **Recalculation of Coordinates**
-  Toolbar: **Topoplan Settings** >  **Recalculation of Coordinates**
-  Command line: **NG\_REPROJECTION**

The command recalculates geocoordinates of topoplan objects to another system using EPSG codes.

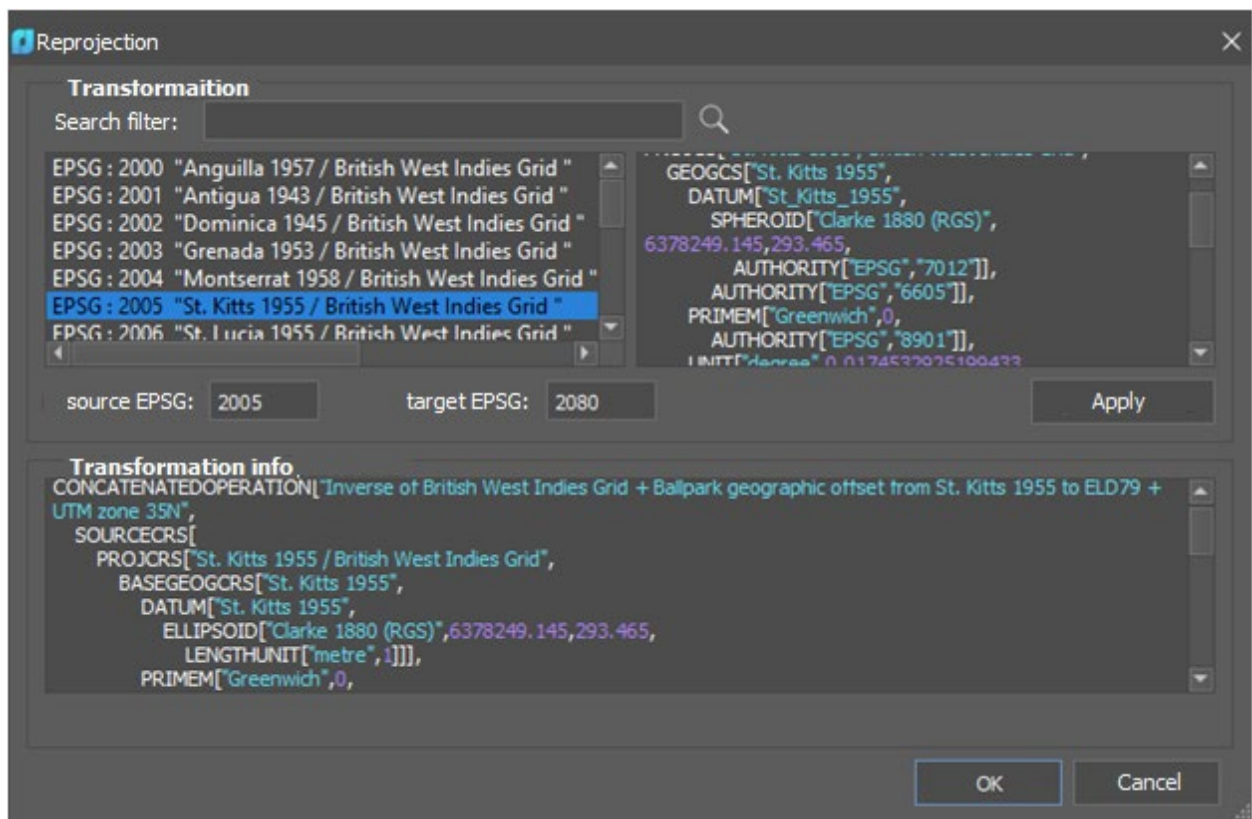

### To recalculate coordinates:

Run the command.

In the dialog box that appears, in the **Source EPSG** and **Target EPSG** fields, enter the number of the source and target coordinate systems according to the EPSG classification, based on the list on the left side of the window. You can use the search filter. When finished, click **Apply**.

Information about the transformation will appear at the bottom of the dialog box. Click **OK** to confirm the transformation.

**NOTE:** The NG\_REPROJECTION command works only with Topoplan and is not intended for recalculation of Point Clouds.

## Creating Geopoints

### Geopoint Object

*Geopoint* is a coordinate geometry oriented (COGO) point, which, in addition to coordinates can contain additional attributes and store styles for displaying labels and markers.

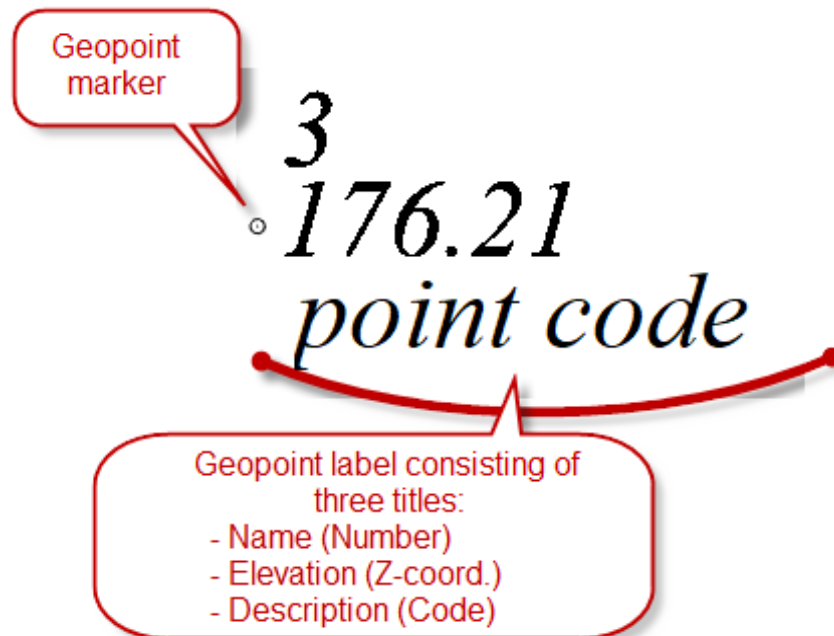

In nanoCAD a geopoint is represented as a separate object. A geopoint and a simple point are different objects: a classic nanoCAD point contains only coordinates.

Geopoints can be imported in the document by the [Import Geopoints](#) command.

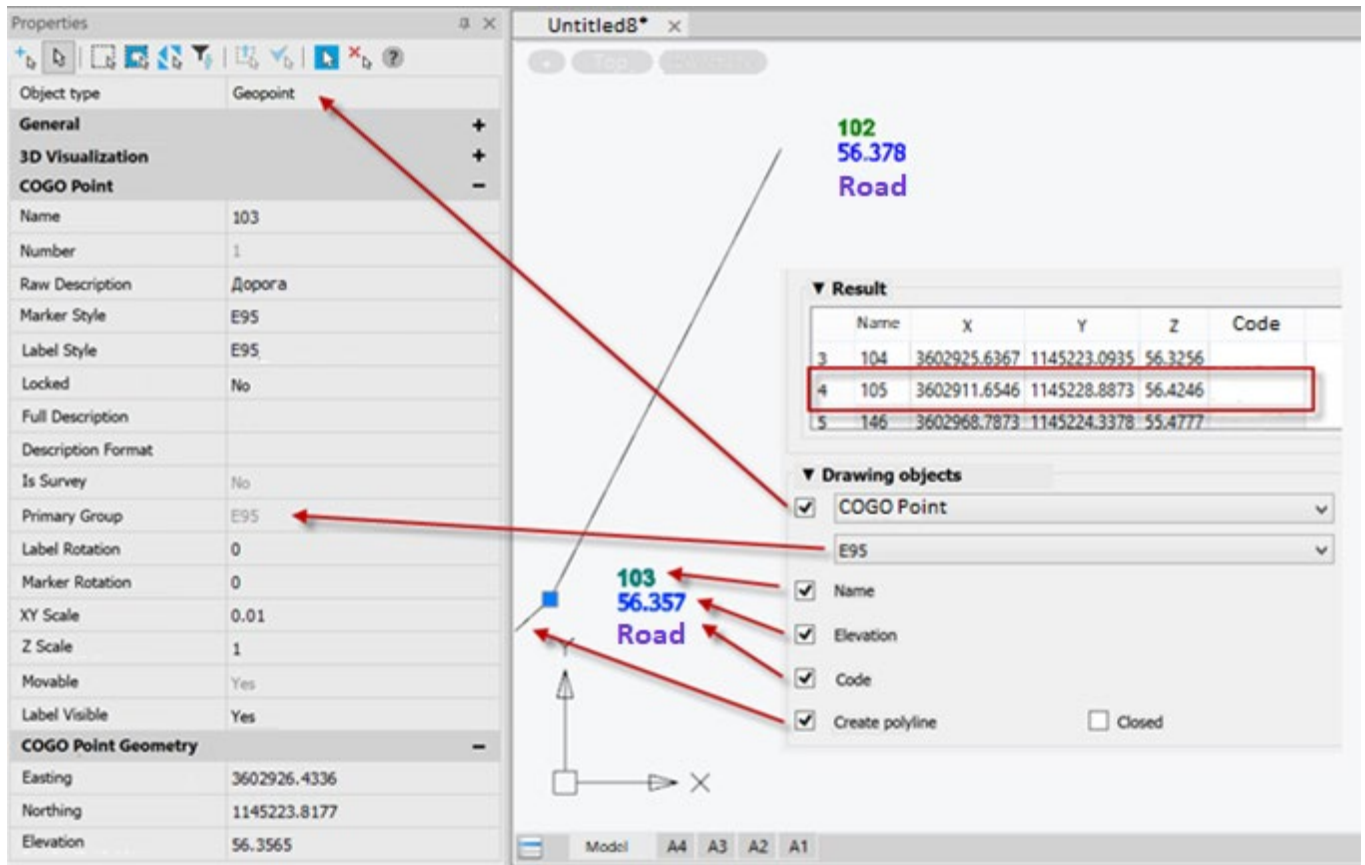

Geopoints can be created manually by the [Create Geopoints Manually](#) command or obtained as a result of the work of the [Explode the Cloud into Points](#) command.

The properties of a geopoint, like any other objects, can be edited in the **Properties** bar.

Geopoints have grips, the movement of which is initiated by: moving a geopoint, rotating a marker, moving and rotating a label. The same parameters can be changed in the **Properties** bar:

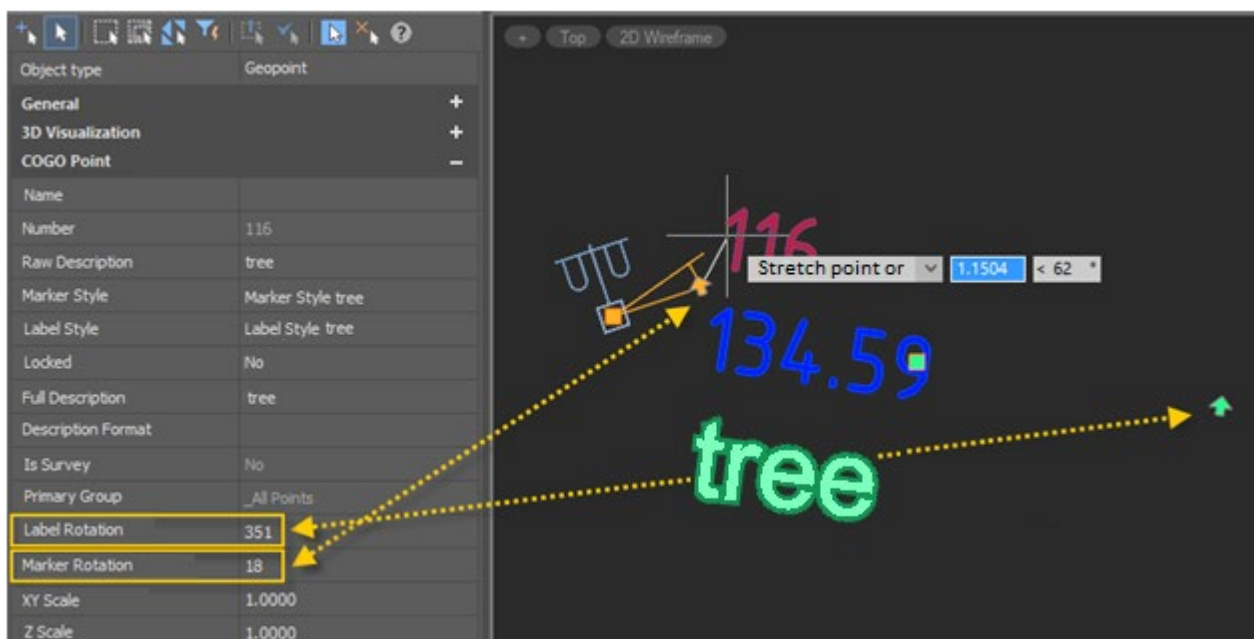

The grip for moving the label allows you to expand the geopoint's label and marker with the formation of a leader with an arrow. To return the label to its previous position, just drag the grip for moving the label onto the grip for moving the geopoint.



It is possible to snap to geopotents in the **Node** mode.

It is possible to change the scale of geopotents. To do this, use the commands - **Toposcale 1:500, Toposcale 1:1000, Toposcale 1:2000, Toposcale 1:5000**. When executing the **Toposcale** command, the presence of geopotents and an ultrasonic classifier in the drawing is checked. If they exist, it is proposed to rescale them.

The following changes are made for geopotents:

- marker sizes in all geopotent marker styles,
- label sizes in all geopotent signature styles.

## Geopotents in the Drawing Explorer

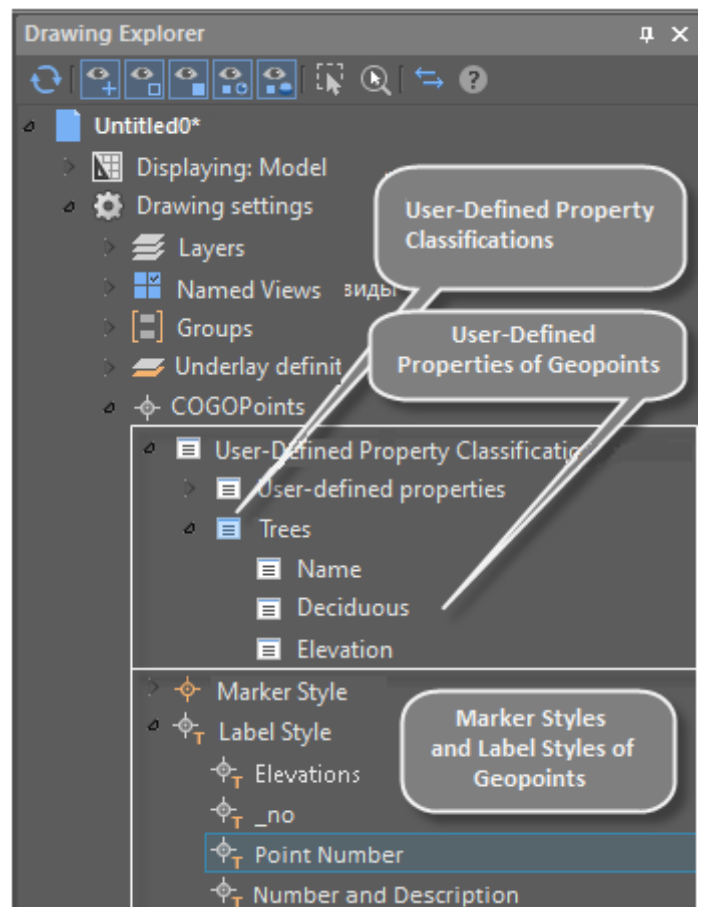
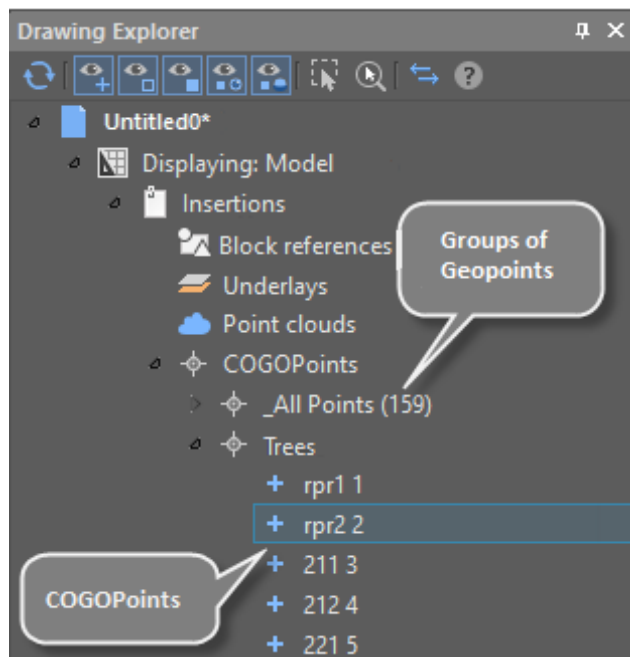

To organize points and control how they are displayed in a drawing, you use collections of named points called *point groups*.

Geopotents are displayed in the [Drawing explorer](#), each in its own group. The same bar displays sets of geopotent marker styles, geopotent label styles, custom properties of geopotents.



## Marker and Label Styles of Geopoints

The *marker styles* and *label styles* of geopoints are used to change the display of a geopoint in the drawing field.

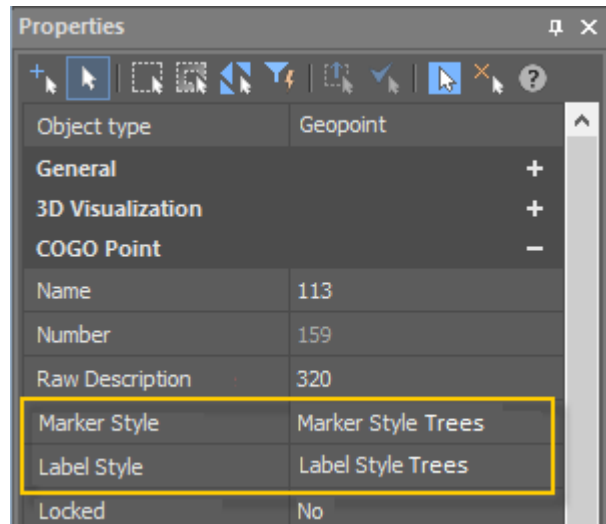

You can create new marker styles and label styles of geopoints from the context menu of **Drawing Settings - COGOPoints - Marker Style** or **Label Style** in the **Drawing Explorer**.

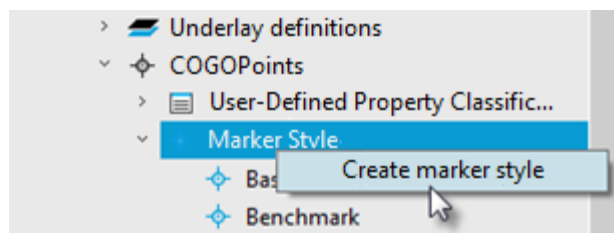

Editing geopoint marker styles is started by double-clicking on the desired marker style in the **Drawing Explorer**. Parameters are configured in the **Properties** bar.

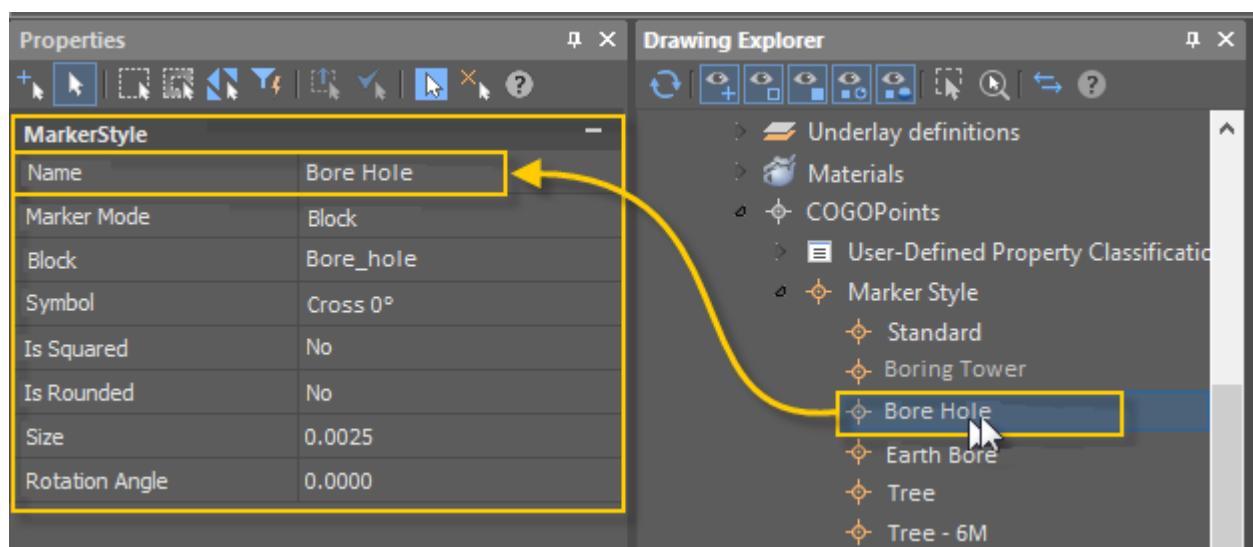

Editing geopoint label styles is started by double-clicking the desired label style in the **Drawing Explorer**. Parameters are configured in the **Properties** bar.

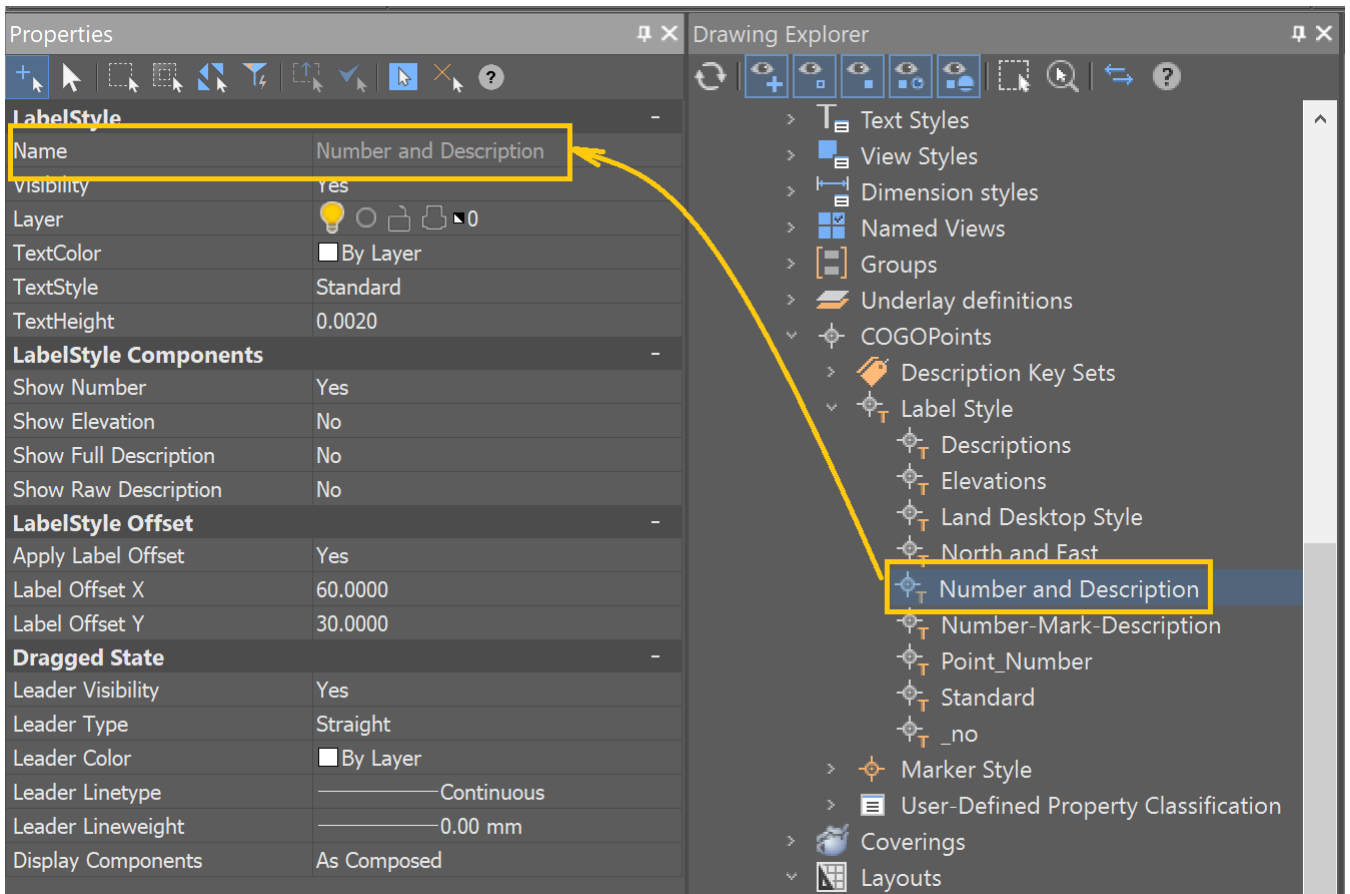

## Geopoint Groups

To organize points and control how they are displayed in a drawing, use collections of named points called *point groups*.

Groups of geopoints can be created by the [Create a Group of Geopoints Manually](#) and [Create Groups of Geopoints by Original Description](#) commands.

Double clicking on the name of a group of geopoints in the **Drawing Explorer** starts editing the parameters of the group in the **Properties** bar:

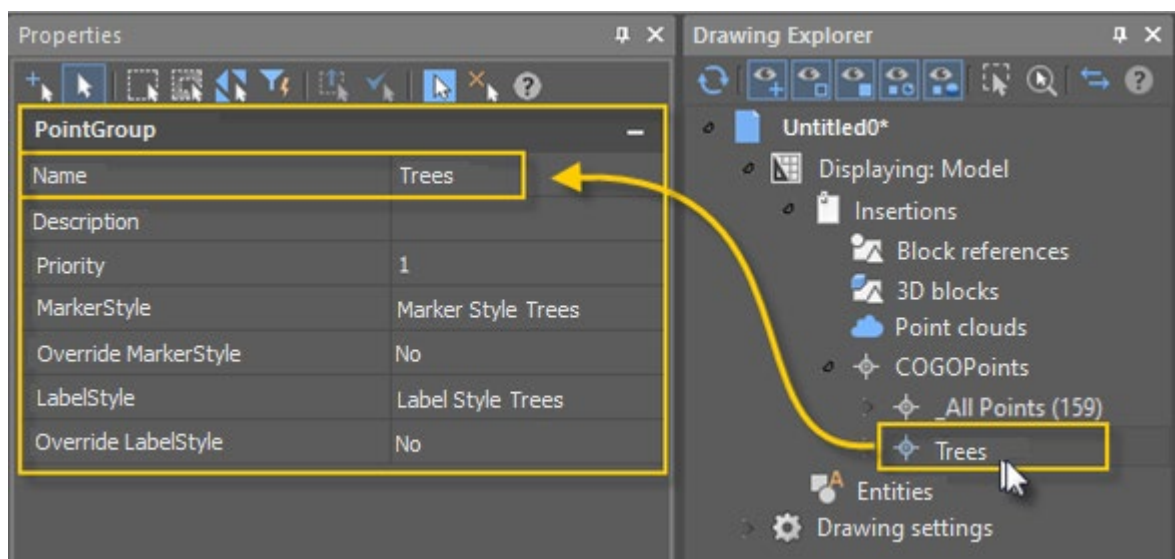

A group can be assigned with a geopoint marker style and a geopoint label style. When style override is enabled, the group style will be applied to all geopoints in that group. After disabling

the style override, the appearance of the marker or label of each point in the group will return to the view specified in the point.

You can rename or delete a group of points using the commands of named group context menu in the **Drawing Explorer**.

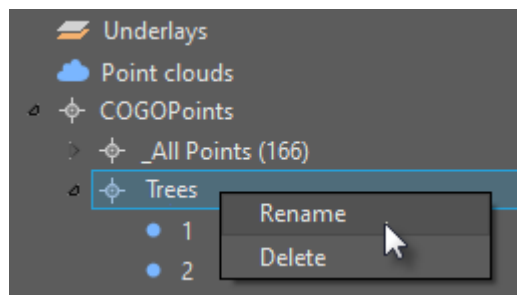

A Description key sets can be applied to a group of geopoints. The command is applied to a group in the drawing explorer using the context menu. More information about description keys in the section Description Key Sets.

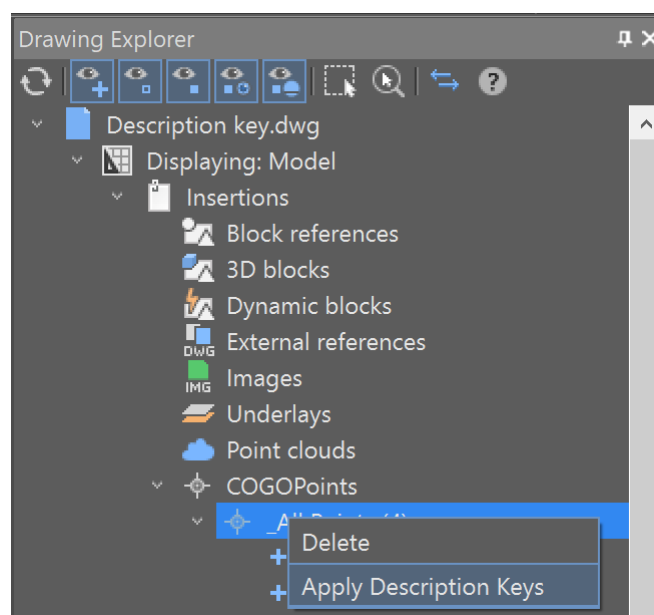

## ***User-Defined Properties of Geopoints***

You can set *user-defined properties* for geopoints. If you have additional data that cannot be distributed over existing standard geopoint properties, you can specify your own user-defined properties.

There are four types of user-defined properties available:

- **String:** allows you to enter text as a value. Is used when you want to enter any alphabetic or numeric characters.
- **Integer:** allows you to enter only whole numbers without decimals.
- **Double:** creates a property that allows you to enter numbers with decimal places.
- **Boolean:** creates a property that allows switching Yes/No (true or false) value.

Geopoint user-defined properties are grouped into *user-defined property classification*. A classification can be created, filled with user-defined properties, or deleted.

Thus, if you have a survey that contains tree data, you can create a **Trees** classification. Then create user-defined properties in it related to this classification.

For example:

- **Name** (String),
- **Deciduous** (Boolean),
- **Elevation** (Double).

All user-defined properties of geopoints and their classifications are displayed in the **Drawing Explorer (Drawing settings - COGO-points - User-defined Property Classification)**.

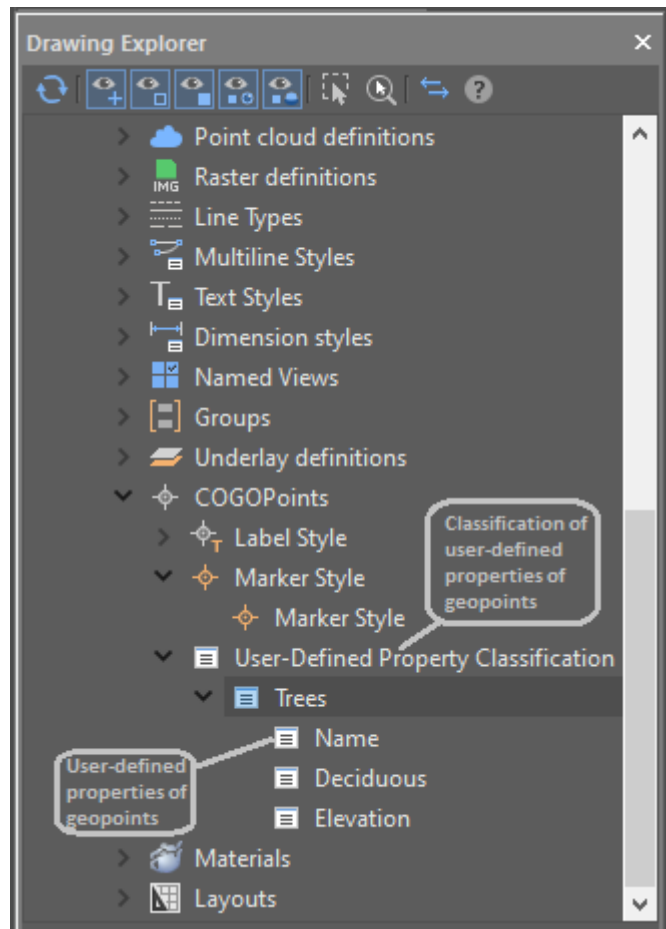

You can view and edit the values of user-defined geopoint properties of the drawing in the **Properties** bar.

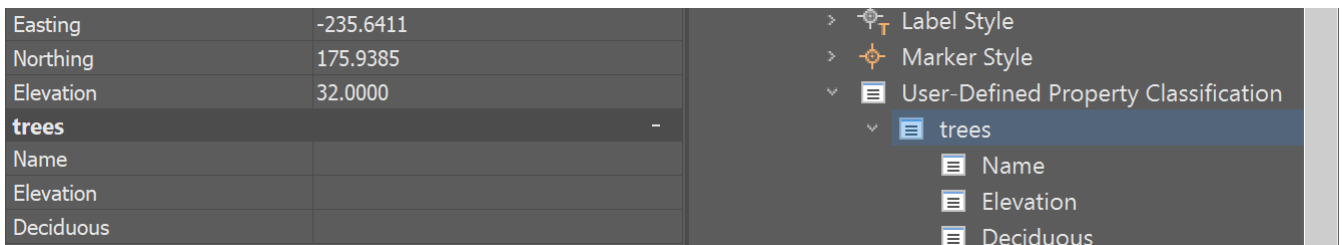

You can create a new user-defined property classification by selecting **Create** in the context menu of the **Drawing settings - COGO Points - User-defined Property Classification** section in the **Drawing Explorer**.

You can create a new custom property by selecting **Create** in the context menu of any user-defined property classification in the **Drawing Explorer**.



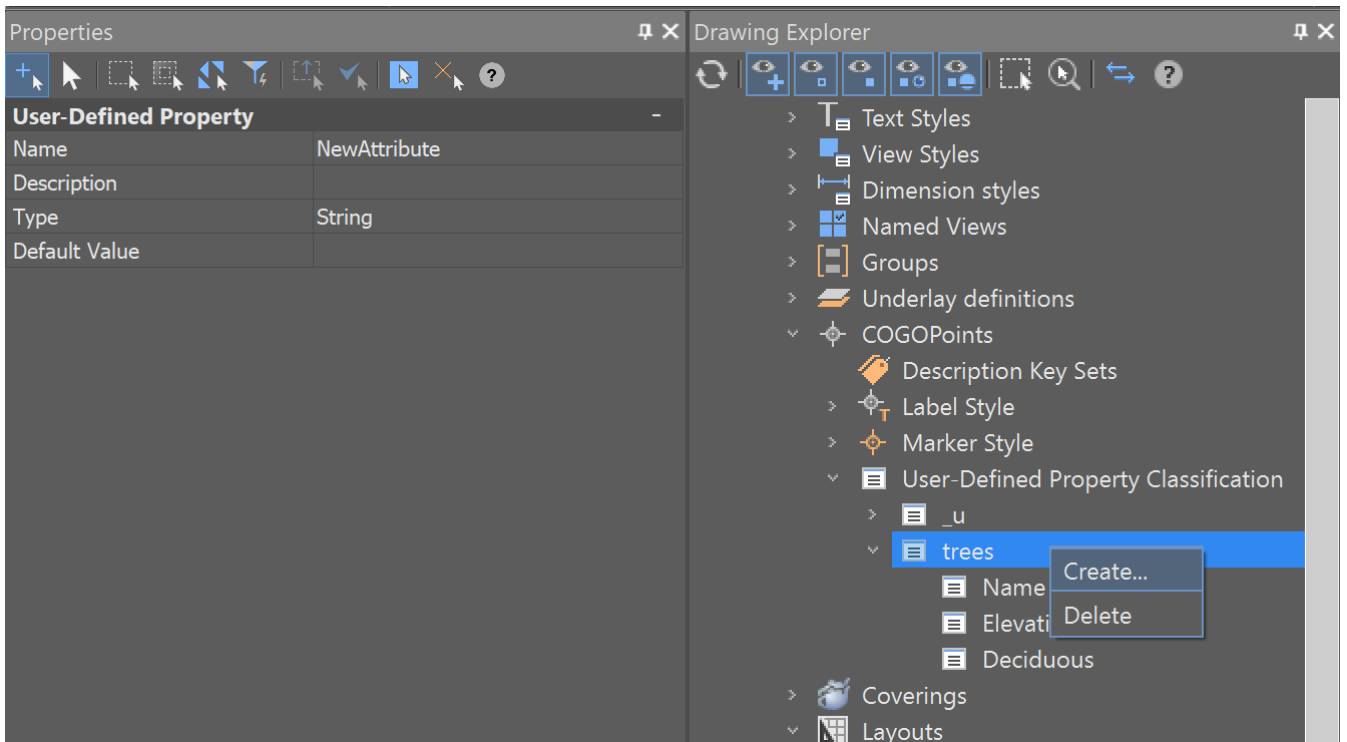



You can set a description for a custom property. The use of descriptions will be implemented in one of the next versions.



User-defined properties can also be assigned during the import of geopoints by the [Importgeopoints](#) command.

You can delete a classification or a user-defined property by selecting **Delete** in their own context menu in the **Drawing Explorer**.

## Ceopoints Manually

-  Ribbon: **Topoplan – Geopoints** >  **Create Geopoints Manually**
-  Menu: **Topoplan – Geopoints** >  **Create Geopoints Manually**
-  Toolbar: **Geopoints** >  **Create Geopoints Manually**
-  Command line: **NG\_CREATE\_POINTS**

When creating, specify the point location in the drawing, description and mark.

### Command prompt:

Specify the location for the new point:

Enter a description of the point <.>:





Specify the elevation of the point <.>:

Specify the point location in the drawing field or enter the point coordinates.







Enter the point description.

Enter the point elevation mark.

Geopoints created by the **NG\_CREATE\_POINTS** command can be edited using the **Properties** bar. For example, you can separately set the rotation angles for a marker and a label. If label and marker styles are missing, then geopoints will be created with the standard style.

Object type	Geopoint
<b>General</b> -	
Layer	    N11
Color	 By Layer
Linetype	————— By Layer
Linetype Scale	1.0000
Plot Style	By Color
Lineweight	————— By Layer
Hyperlink	
Transparency	ByLayer
<b>3D Visualization</b> -	
Material	ByLayer
Visual style	None
<b>COGO Point</b> -	
Name	
Number	1
Raw Description	N11
Marker Style	Standard
Label Style	Standard
Locked	No
Full Description	N11
Description Format	
Is Survey	No
Primary Group	N11
Label Rotation	0
Marker Rotation	<b>47</b>
XY Scale	1.0000
Z Scale	1.0000
Movable	Yes
Label Visible	Yes
<b>COGO Point Geometry</b> -	
Easting	-56.6812
Northing	456.4182
Elevation	55.0000

## Creating Geopoints by Points and Texts

-  Ribbon: **Topoplan – Geopoints** >  **Creating Geopoints by Points and Texts**
-  Menu: **Topoplan – Geopoints** >  **Creating Geopoints by Points and Texts**
-  Toolbar: **Geopoints** >  **Creating Geopoints by Points and Texts**
-  Command line: **NG\_CREATE\_POINTS\_BY\_TXT**

The command creates geopoints by points (circles, blocks) and text objects (Texts, MTexts) found at a specified distance. The maximum distance for text search is specified in the drawing.

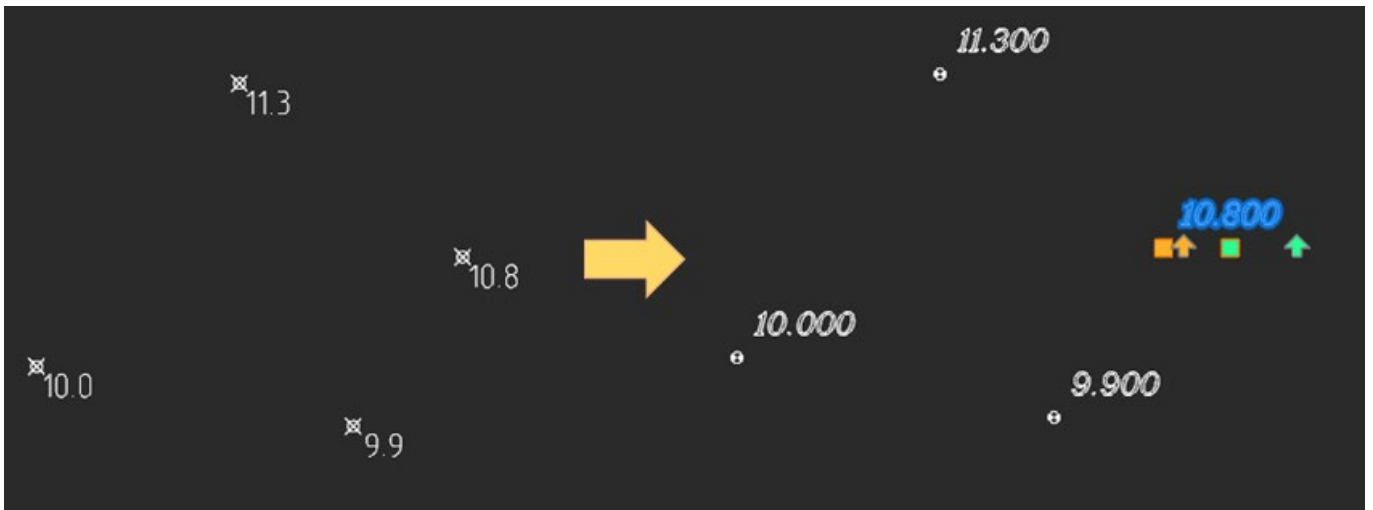

**Command prompts:**

Select objects or [?]:

Text with elevation <Both> or [Text/MText/Both]:

Max Distance. Specify first point:

Specify second point:

Remove original objects? <Yes> or [Yes/No]:

Input a new COGO group name or [AllPoints]:

Select objects to be converted to geopot.

Specify the type of text objects from which information for geopot labels should be taken: single-line text, multi-line text, or both at the same time.

With a mouse click, specify on the drawing the first point of the maximum possible distance from the point to its label.

Within this distance from a point (circle or block), the command will search for a text object - a label

Specify a distance with a small margin: a little more than the maximum distance from a point to its label (text object) in the drawing.

Specify the second distance point.

Specify whether to delete the original objects or not.

Enter a name for a new group of geopot or accept the proposed name.

The parameters of the **Creating Geopot by Points and Texts** command are configured in the **Properties** bar.

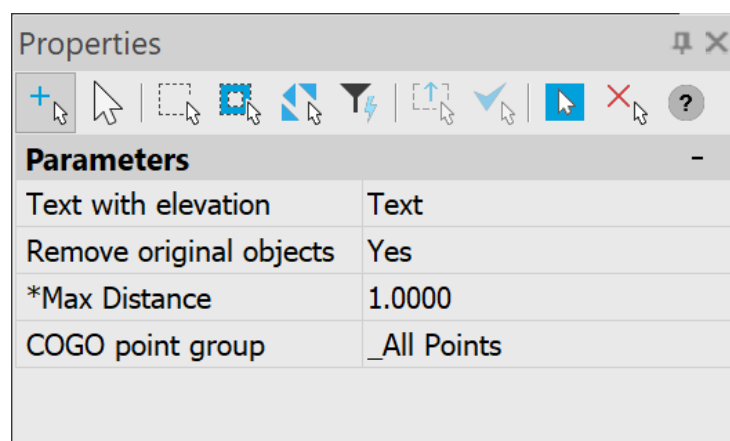

- **Text with elevation;**

- **Remove original objects;**
- **Max Distance;**
- **COGO point group;**

<b>Text with elevation</b>	Selection of single-line and multi-line text to get a label, or both.
<b>Remove original objects</b>	Specifies whether to delete the original objects or not.
<b>Max Distance</b>	Distances from point to text.
<b>COGO point group</b>	Creating a group for new geopoints (if the group is not specified, put it in the <code>_All Points</code> group)

## Creating Geopoints by Interpolation

 Ribbon: **Topoplan – Geopoints** >  **Creating Geopoints by Interpolation**

 Menu: **Topoplan – Geopoints** >  **Creating Geopoints by Interpolation**

 Toolbar: **GeoPoints** >  **Creating Geopoints by Interpolation**

 Command line: **NG\_CREATE\_POINTS\_BY\_INTERPOLATION**

The command creates new geopoints by interpolation between two points specified in the drawing.

### Command prompts:

Specify the first point or  
[Settings]:

Specify the second point or  
[Settings]:

Specify points count <1> or  
[Settings]:

[Settings]:

Apply changes

[Yes/No/save/saveDefault]

<Yes>:

Specify the first point of the distance.

Specify the second point of the distance.

Yes – the command will be performed taking into account the settings changes made by the user in the current command session.

No – the command will be performed with the settings that were displayed immediately after the command was launched.

save – saving settings to the document.

saveDefault – saving settings to the register.

Labels of new geopoints are obtained by interpolation between the specified ones. Several points can be added sequentially. Press the **ESC** button to end the command.

## Creating Geopoints by Surface

 Ribbon: **Topoplan – Geopoints** >  **Creating Geopoints by Surface**



 Menu: **Topoplan – Geopoints** >  **Creating Geopoints by Surface**

 Toolbar: **GeoPoints** >  **Creating Geopoints by Surface**

 Command line: **NG\_CREATE\_POINTS\_BY\_TIN**

The command creates new geopoints at the nodes of surface faces. Geopoints take X, Y, Z coordinates from surface nodes. The geopoint style is assigned by default (Standard).

#### **Command prompts:**

Select objects                      Select a surface in the drawing field.  
or [?]:

The command line will display the number of points created.

```
NG_CREATE_POINTS_BY_TIN - Creating Geopoints by Surface
Select objects or [?]: ?
820 found
Select objects or [?]:
7 Points created
```

The command has no options.

## **Point Conversion**

 Ribbon: **Topoplan – Utilities** >  **Point Conversion**

 Menu: **Topoplan – Utilities** >  **Point Conversion**

 Toolbar: **Topoplan Utilities** >  **Point Conversion**

 Command line: **NG\_CONVERT\_POINTS**

The command converts point objects: points to geopoints and blocks, blocks to points and geopoints, geopoints to points and blocks.

Convert to
— □ ×

**▼ Selected objects**

<input checked="" type="checkbox"/>	COGO Point (3)	Name	Increment	Elevation	By point	Code	By point
<input checked="" type="checkbox"/>	Simple Point (6)	Name	Increment	Elevation	By point	Code	By point
<input checked="" type="checkbox"/>	Block (611)	Name	Increment	Elevation	By point	Code	By point

**▼ Data**

	Name	X	Y	Z	Code
4	3	2226559.16	497569.11	2.00	
5	Simple Points				
6	4	2226528.93	497641.99	0.00	
7	5	2226535.13	497626.77	0.00	

**▼ UDP classification**

+
-

**▼ Filters**

+
-

**▼ Drawing objects**

<input checked="" type="checkbox"/>	COGO Point	0	By Layer
	Text style	Standard	
	COGO point group	Create new...	
<input checked="" type="checkbox"/>	Name	T	By Layer
<input checked="" type="checkbox"/>	Elevation	T	By Layer
<input checked="" type="checkbox"/>	Code	T	By Layer

Current profile:

Default
+
-

Ok
Cancel
Additional Options

**Options:**

**Selected objects**

The section defines which types of point objects selected in the drawing should be converted to another type and where to get values for mark labels.

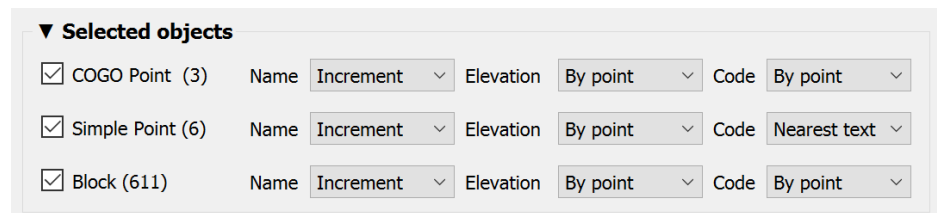

Object Type	Name	Elevation	Code
<input checked="" type="checkbox"/> COGO Point (3)	Increment	By point	By point
<input checked="" type="checkbox"/> Simple Point (6)	Increment	By point	Nearest text
<input checked="" type="checkbox"/> Block (611)	Increment	By point	By point

You can convert geodata simultaneously from all or selectively from the following types of point objects:

- Simple objects of the **Point** type with mark labels in the form of ordinary text objects;
- **Block** insertions with single-line attributes as mark labels (for example, conventional signs inserted into the drawing as blocks from the **Conventional Signs** toolbar);
- **COGO Point** type objects with a label.

Values for labels can be taken from the increment, attributes of the point itself, or from the text object nearest to the point:

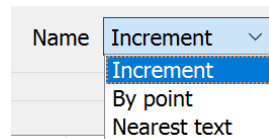

If you select **By point**, you will need to specify from which attribute of the point the information should be taken. The list will show the existing attributes of the geopoint or block:

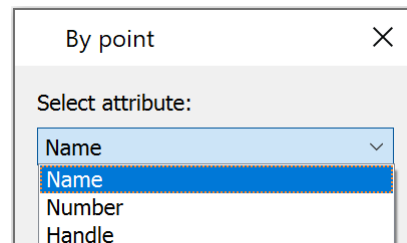

If you select **Nearest text**, you will need to specify the maximum distance from the point to the text object at which this text will still be considered the label of this point:

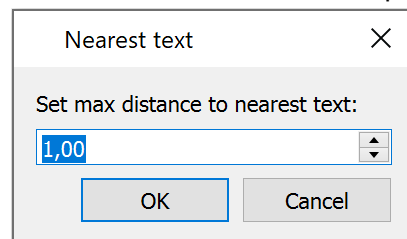

## Data

The table typifies and edits the data obtained from point objects: point coordinates by X, Y and Z, numbers, descriptions of points. The column heading displays the data type. In case of incorrect initial data typing, you can drag one header to another, thereby mutually changing them.

	Name	X	Y	Z	Code
1	3602926.4336	103	1145223.8177	56.3565	Road
2	3602926.7140	102	1145224.3639	56.3777	Road
3	3602925.6367	104	1145223.0935	56.3256	Road

	X	Name	Y	Z	Code
1	3602926.4336	103	1145223.8177	56.3565	Road
2	3602926.7140	102	1145224.3639	56.3777	Road
3	3602925.6367	104	1145223.0935	56.3256	Road

You can delete selected cells, rows, or columns. Multiple selection is supported using **SHIFT** and **CTRL**. Rows or columns are selected by clicking on the heading. Before manually deleting data, it is recommended to filter it out using filters.

You can also edit the data after double-clicking on a cell.

**Result**

	Name	X	Y	Z
1	103	3602926.4336	1145223.8177	56.3565
2	102	3602926.7140	1145224.3639	56.3777
3	104	3602925.6367	1145223.0935	56.3256

**Drawing objects**

- COGO Point
- Create new...
- Number
- Elevation



Undo	Ctrl+Z
Redo	Ctrl+Y
Cut	Ctrl+X
Copy	Ctrl+C
Paste	Ctrl+V
Delete	
Select All	Ctrl+A

### UPD classification

You can add custom properties to points with the  button. You should specify the type (integer, float, or string) and name.

**▼ UDP classification**

Evaluation Float ▾

A new empty column with the name of the custom parameter appears in the **Data** table. Drag this column heading onto the heading of the column you want it to match.

**Data**

	Y	X	Z	Name	Code	6	Evaluation
1	-48.82890000	4187.59900000	212.90300000	rpr1	542	213.20000000	
2	-123.10210000	4063.75720000	212.53600000	rpr2	856	212.88000000	

**Data**

	Y	X	Z	Name	Code	Evaluation	6
1	-48.82890000	4187.59900000	212.90300000	rpr1	542	213.20000000	
2	-123.10210000	4063.75720000	212.53600000	rpr2	856	212.88000000	

## Filters

You can exclude data from conversion not only manually by deleting cells from the **Data** table, but also by setting filters. For example, you can exclude from the conversion all points with heights below 52 (column Z) and with a number greater than 350 (**Name** column).

**Data**

	Name	X	Y	Z	Code
31	323	3602972.7284	1145119.3574	53.4285	Talweg
32	324	3602972.1919	1145105.2899	53.2409	Talweg
33	325	3602972.4566	1145091.8164	53.0922	Talweg
34	326	3602974.2005	1145077.2130	52.9270	Talweg

**Filters**

Z  Regular Expression >52

Name  Regular Expression <350

+
-

After adding the filter with the + button, in the drop-down list, select the column by which all converted data will be filtered. Then set the value the column data should satisfy. The rest of the lines will be excluded from conversion. Hovering over a filter displays a tooltip with sample values.

**Filters**

Z  Regular Expression >52

Name  Regular Expression <350

+
-

**Standart filter :**

Filter	Result
100	include 100
!100	exclude 100
10:100	from 10 to 100
:100	from inf to 100
10:	from 10 to inf
>10	from 11 to inf
<100	from inf to 99
>10, <50, 300	from 11 to 49 and 300

It is recommended to set filters only after correct data typing in the **Data** section.

## Drawing objects

The section determines what type of objects the received drawing point data should be converted into. And also what signatures the point label will consist of, and what design they will have.

You can import geodata in the form of:

- Ordinary objects of **Point** type with labels in the form of text objects;
- **Blocks** (similar to blocks of the **Conventional signs** toolbar);
- Objects of **Geopoint** type with a label.

In case of data conversion into a **Geopoint** object, you should specify a group for them below, in the drop-down list of groups.

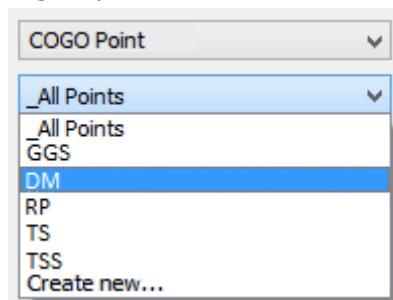

The list contains only groups of geopoints that exist in the current drawing. To create a new group, select the **Create new** option and enter a name for the new group.

If **Block** was selected, the points will be represented as block insets with single-line attributes to display labels. To do this, a new block will be created in the drawing. The conventional sign for the point marker will be taken from the block in the drop-down list below.

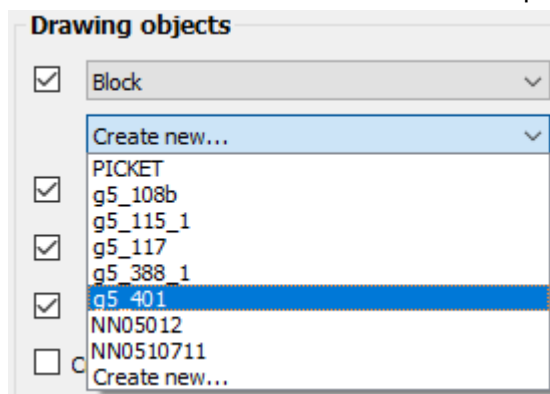

Only those blocks that already exist in the current drawing are available in the block list. To make the blocks of the **Conventional signs** bar available, insert at least one symbol into the drawing.

The blocks will be inserted with a scale that takes into account the values of the current topographic scale.

If instead of selecting an existing block in the list, the **Create new** option was selected, then after the conversion starts, the block editor will open to create a point marker (conventional sign) block. The default is a circle. In the block editor, edit the marker, save the block, and exit the editor to complete the conversion.

You can specify which labels will be displayed in the geopoint label on the drawing: name (geopoint number), elevation (Z-coordinate) and code (point description).

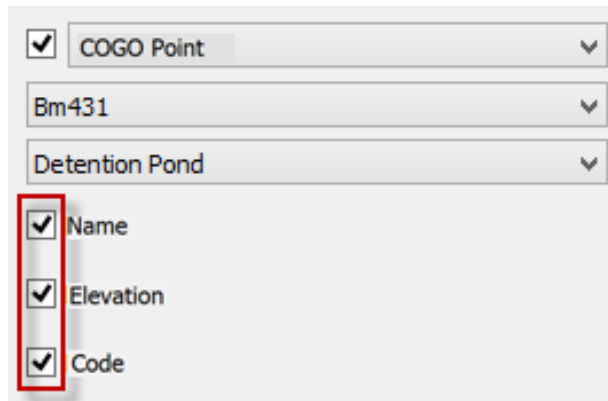

Individual layers and color can be assigned to place points and labels.

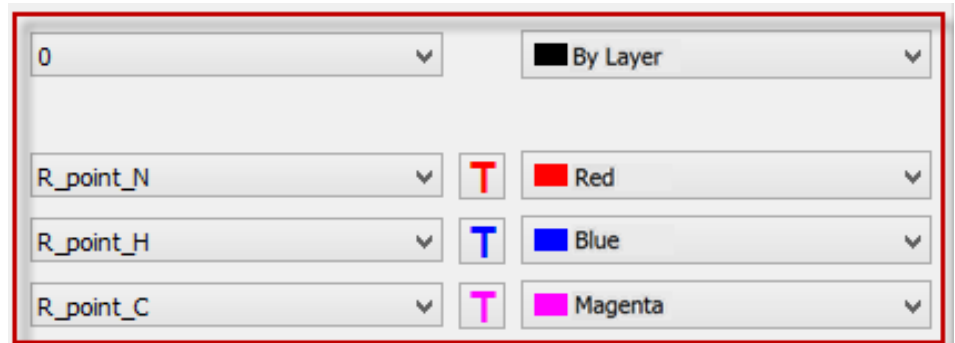

Labels can be assigned with a font.

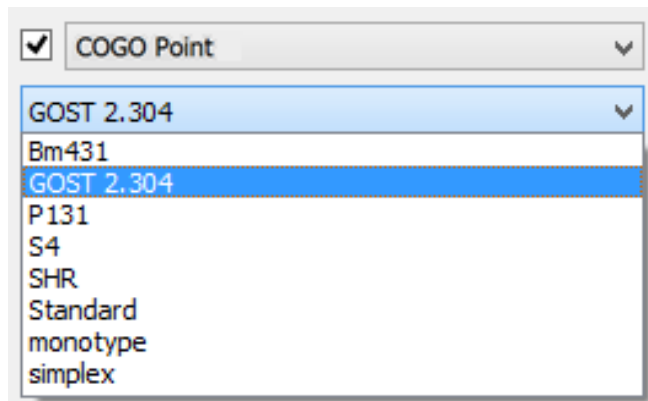

### Current profile

Allows you to save all the settings made in the dialog to a profile for later use.

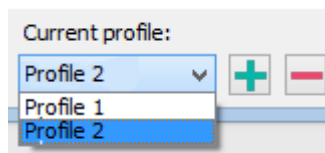

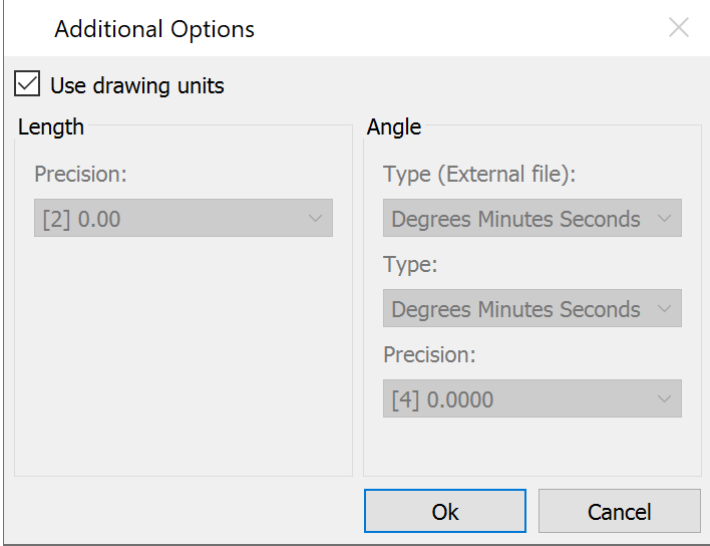

<p><b>Additional options</b></p>	<p>The Additional Options button opens a window where you can change settings for the units (UNITS) with which geopoints should be imported. By default, the current drawing units are used.</p> 
----------------------------------	---

## Creating a Group of Geopoints Manually

 Ribbon: **Topoplan – Geopoints** >  **Create Groups of Geopoints Manually**

 Menu: **Topoplan – Geopoints** >  **Create Groups of Geopoints Manually**

 Toolbar: **Geopoints** >  **Create Groups of Geopoints Manually**

 Command line: **C3D\_CREATE\_COGO\_POINT\_GROUP**

Manual creation of a group of geopoints with a name, description, styles, and a prefix of the raw description of the geopoint, which is a criterion for adding points to the group.

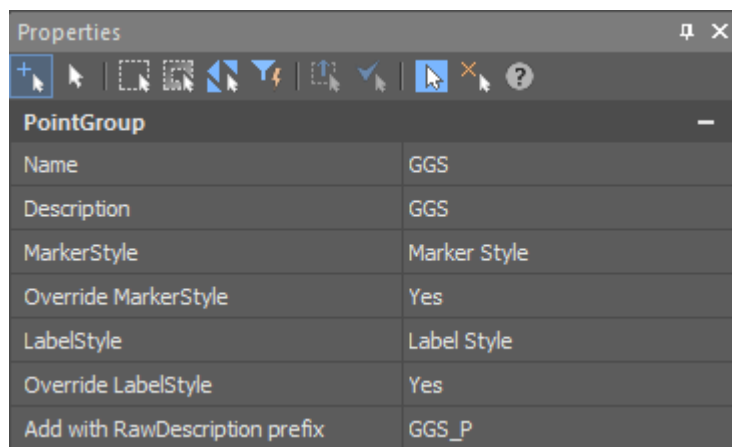

The command options are set in the **Properties** bar:

- **Name;**
- **Description;**
- **Marker Style** (of those existing in the drawing);
- **Override Marker Style;**

- **Label Style** (of those existing in the drawing);
- **Override Label Style**;
- **Add with Raw Description prefix** - the criterion for adding a point to the group. Allows you to add to the group only points with the specified raw description.

### Command prompts:

Change parameters in 'Properties' window and choose 'OK' to create Point Group or 'Cancel' to discard any changes <OK> or [OK/Cancel]:

Yes – a group of geopoints will be created with the current settings.  
Cancel – if the settings have been changed, they will not be preserved. A group of geopoints will be created with the settings displayed right after the command starts.

## Creating Groups of Geopoints by Original Description

 Ribbon: **Topoplan – Geopoints** >  **Create Groups of Geopoints by Original Description**

 Menu: **Topoplan – Geopoints** >  **Create Groups of Geopoints by Original Description**

 Toolbar: **Geopoints** >  **Create Groups of Geopoints by Original Description**

 Command line: **C3D\_CREATE\_COGO\_POINTS\_GROUPS\_BY\_RDESCR**

Automatic creation of geopoint groups. All points with the same raw description are combined into one group. As many groups are created as different raw descriptions were found in Geopoints in the drawing. The names of the created groups coincide with the raw descriptions.

The command has no options.

## Creating Label Styles of Geopoints

 Command line: **C3D\_CREATE\_COGO\_LABEL\_STYLE**

The **Label style** command allows you to create a geopoint label style and is launched from the context menu of the section **Drawing settings - COGOPoints - Label style** in the **Drawing Explorer**.

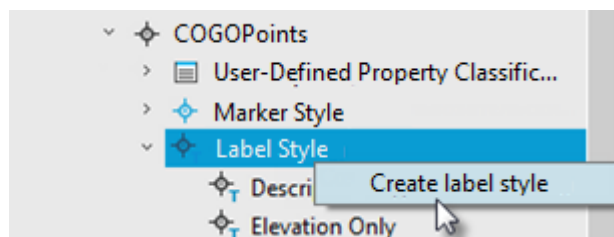

Parameters of the label style being created are configured in the **Properties** bar and are discussed in the **Editing Label Styles of Geopoints** section.

## Creating Marker Styles of Geopoints



Command line: **C3D\_CREATE\_COGO\_MARKER\_STYLE**

The **Marker style** command allows you to create a geopoint marker style and is launched from the context menu of the section **Drawing settings - COGOPoints - Marker style** in the **Drawing Explorer**.

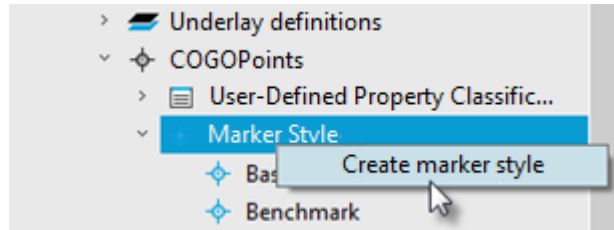



The parameters of the marker style being created are configured in the **Properties** bar and are discussed in the **Editing Marker Styles of Geopoints** section.

## Editing Label Styles of Geopoints

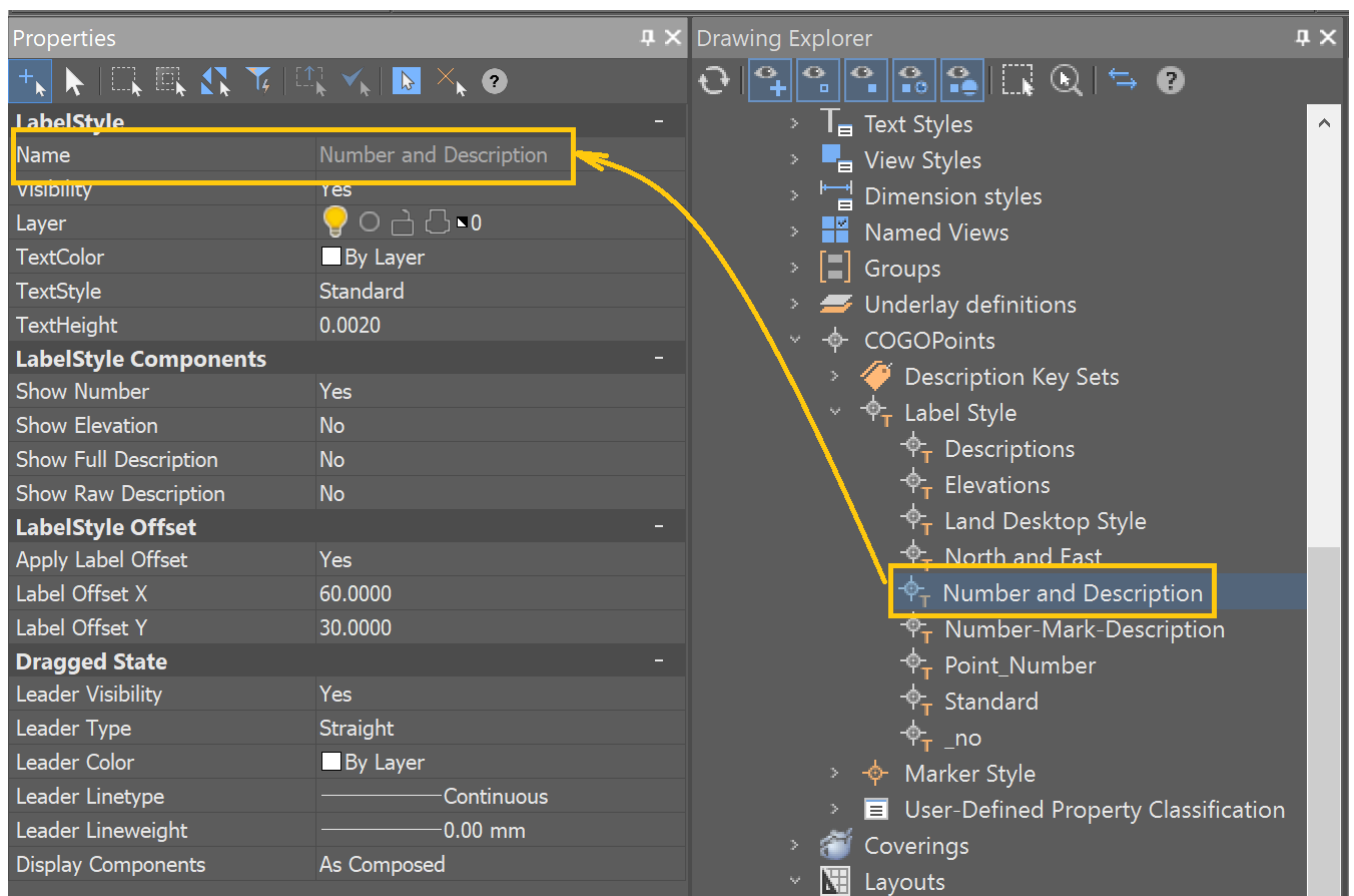
Editing label styles is started by a double clicking the desired label style of a geopoint in the **Drawing Explorer**. The options are set in the **Properties** bar.

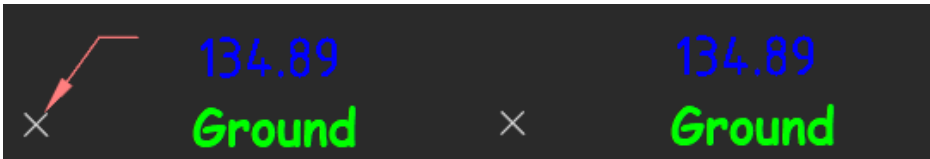

**Options:**

<i>Leader</i>	
<b>Visibility</b>	<p>Whether the leader line should be visible after being dragged from its original position.</p> 
<b>Leader type</b>	<p>Leader line shape: straight or spline.</p> 
<b>Leader color</b>	Color of the leader.
<b>Leader linetype</b>	Linetype of the leader.
<b>Leader lineweight</b>	Lineweight of the leader.
<b>Components display</b>	<p>Determines how the label's contents are displayed after being dragged from the default position.</p> <p>Configuration Preserved: Labels retain their initial layout and orientation settings. When this value is selected, all other properties in the Motion State Components category will not be editable.</p> <p>Grouped Text: Converts labels according to the Motion State Components category settings.</p> <p>Selecting Grouped Text removes all boxes, lines, ticks, and directional arrows. Text components are arranged as fractional text vertically in the order specified by the label style.</p>

**Command prompts:**

Change parameters in 'Properties' window and choose 'OK' to save changes or 'Cancel' to discard any changes <OK> or [OK/Cancel]:

Yes – all changes to label style properties made in the **Properties** bar will take effect.

Cancel – all changes to label style properties made in the **Properties** bar during this session of the command work will be cancelled.

**NOTE:** Unused geopoint label styles can be deleted. Once a style is in use, it cannot be deleted.

## **Editing Label Properties of Geopoints**

Editing label properties of geopoints is started by double-clicking the desired geopoint label style in the **Drawing Explorer**. Settings are configured in the **Properties** bar.

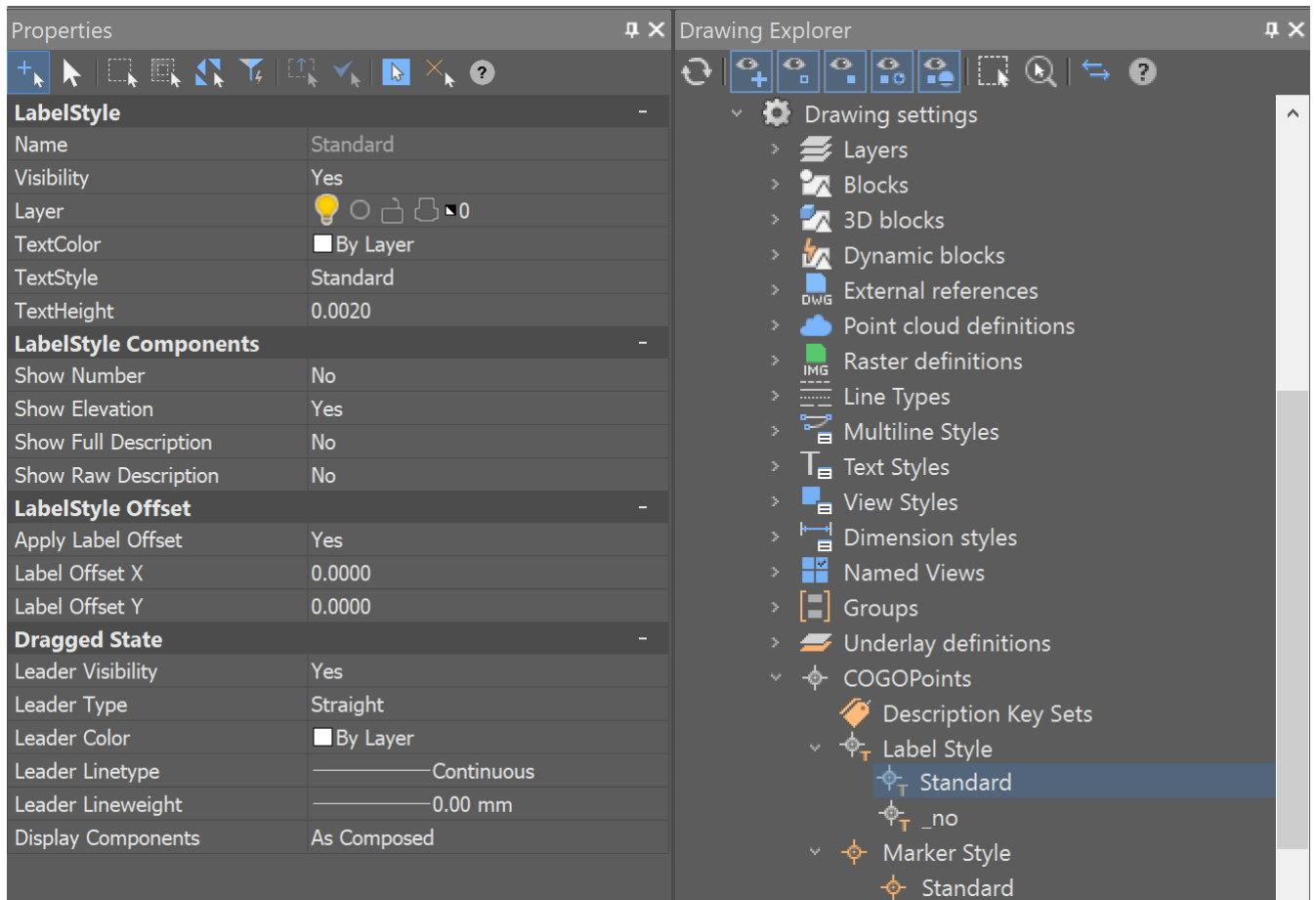

The LabelStyle Offset is a parameter that manages the position of label relative to insertion point. The values are set in drawing units.

The Display Components parameter manages reordering of the displayed components.

## Editing Marker Styles of Geopoints

Editing marker styles is started by a double clicking the desired marker style of a geopoint in the **Drawing Explorer**. The options are set in the **Properties** bar.

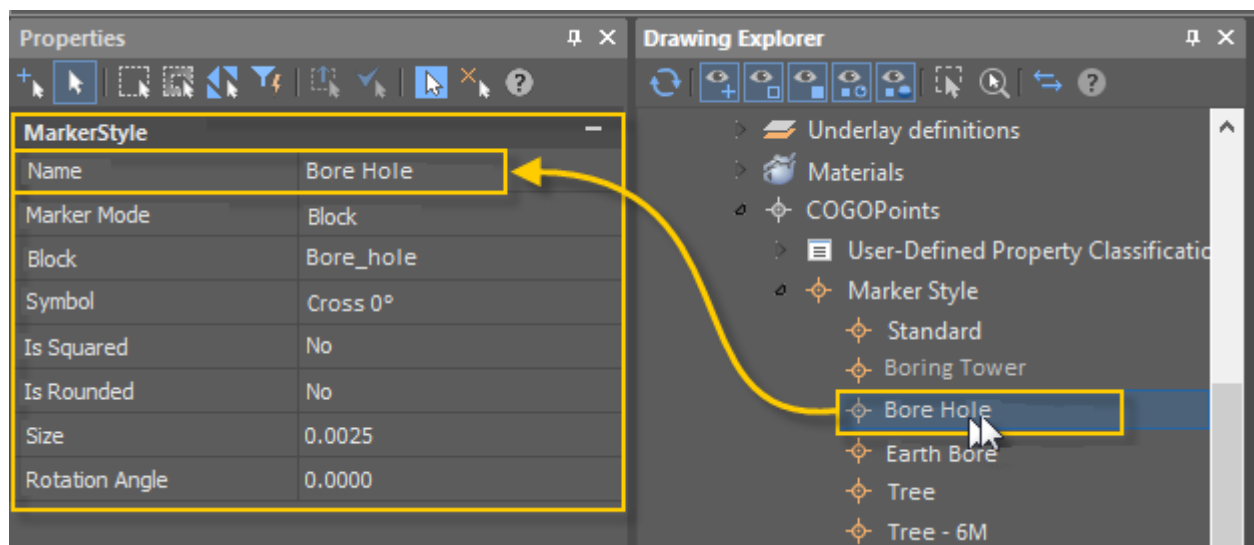

### Command prompts:

Change parameters in

Yes – all changes to marker style properties

'Properties' window and choose 'OK' to save changes or 'Cancel' to discard any changes <OK> or [OK/Cancel]:

made in the **Properties** bar will take effect. Cancel – all changes to marker style properties made in the **Properties** bar during this session of the command work will be cancelled.

## Editing Properties of Geopoint Groups

Double click on the name of the Geopoint group in the **Drawing Explorer** starts editing its parameters in the **Properties** bar:

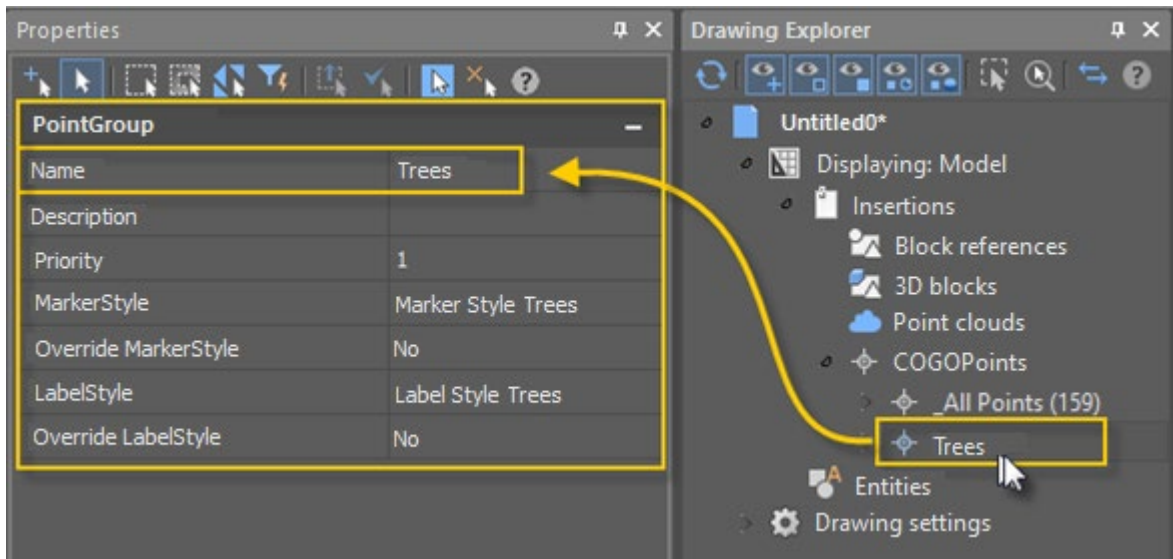

### Command prompts:

Change parameters in 'Properties' window and choose 'OK' to create User-Defined Property or 'Cancel' to discard any changes <OK> or [OK/Cancel]:

OK – all changes of geopoint group properties made in the **Properties** bar will take effect. Cancel – all changes of geopoint group properties made in the **Properties** bar during this session of the command work will be cancelled.

## Description Key Sets and Description Keys

### Description Key Sets

Sets of description keys are used to create and manage description keys.

#### Creating a Description Key Set



Command line: `__aec_create_desckeyset`

You can create a new set of description keys by selecting the **Create** item in the context menu of the **Drawing Explorer** – **COGOPoints** – **Description Key Sets** in the **Drawing Explorer**. Next, in the **Properties** bar, specify the set name and description.

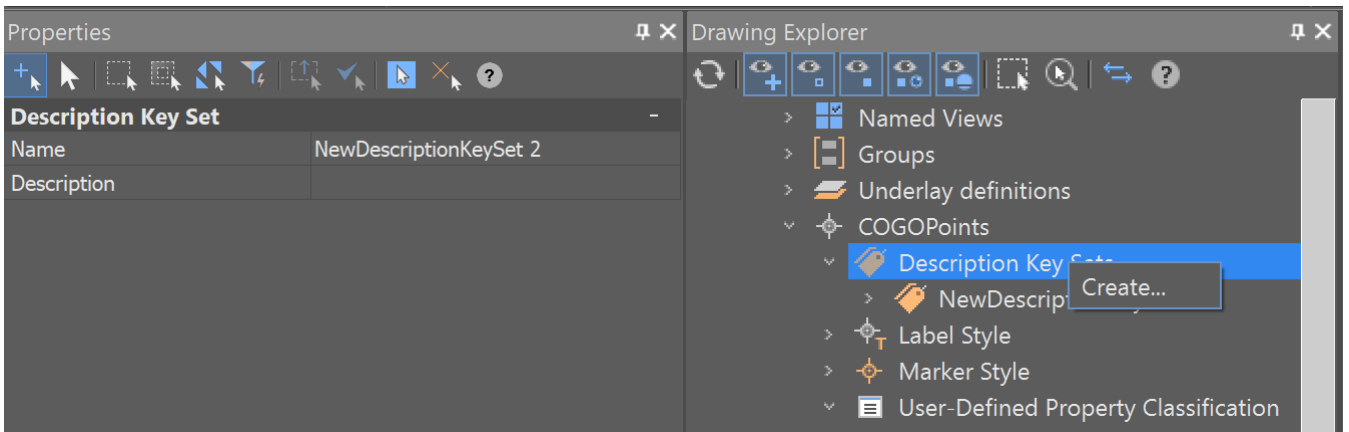

## Deleting a Description Key Set



Command line: `__aec_delete_desckeyset`

You can delete a description key set by selecting **Delete** from their own context menu in the **Drawing Explorer**.

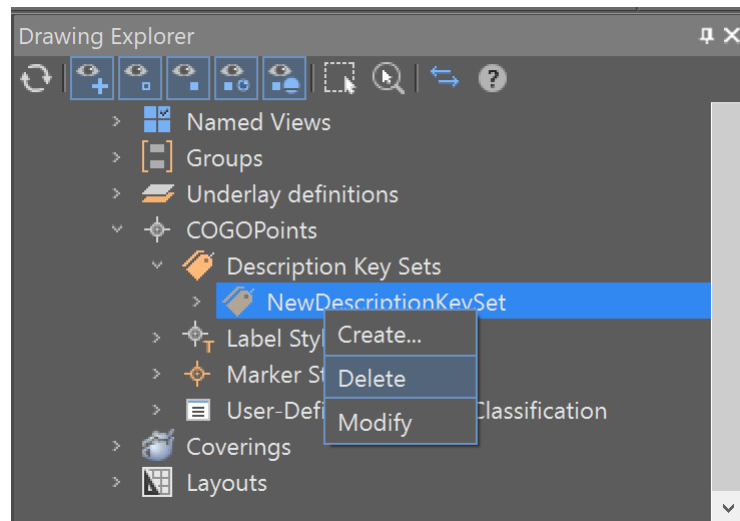

## Modifying a Description Key Set



Command line: `__aec_modify_desckeyset`

You can view and edit a description key set by selecting **Modify** in the context menu of the **Drawing Settings – COGOPoints – Name of Description Key Set** in the **Drawing Explorer**. Next, in the **Properties** bar, specify the set name and description.

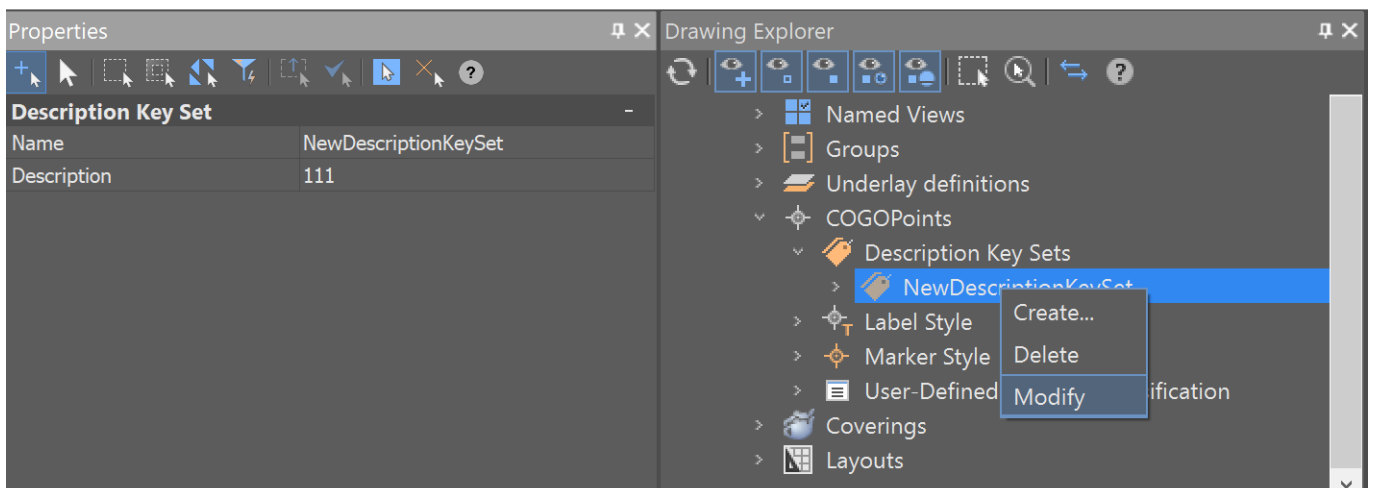

## Description Keys

Description keys are used to automatically control certain properties of drawing points, such as a point appearance in the drawing, when points are created or imported.

Each drawing description key is defined by its own set of properties.

**Code property.** Used when searching for a match against a description key. For example, if the code matches the raw point description, the properties defined in that description key will be applied to the created point. The code may contain wild card characters that enhance the ability to match the description key. For more information, see the Description Key Code section.

**Format property.** Translates the raw description for a point into a full description. If the **Format** property is not set, the default value \$\* will be used. The value \$\* indicates that the raw and full descriptions are the same.

Styles are selected from preset styles. Layer – from one of those existing in the drawing.

Description keys are stored in a drawing as sets.

### Code of a Description Key

The Code property is used to define the raw descriptions that match the description key.

A description key consists of a code and a set of additional properties. If the code matches the raw description, the created point is characterized by other properties specified in the description key.

Below there are examples of description key codes:

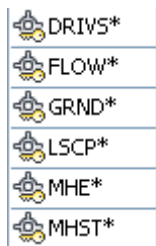

You can specify a simple string as the description key code, or you can use wildcard characters, such as an asterisk (\*), to expand the search options for matching the description key.

Below there is a table of wildcard characters used in description key codes:

Character	Description
#	Matches any digital character.
@	Matches any letter character.
.	Matches any character other than a letter or digit.
*	Matches any sequence of characters; can be anywhere in the search string.
?	Matches any single character (for example, for the search pattern ?BC, the string ABC would be the same as string 3BC).
~	Matches any string that does not contain the specified character sequence (for example, the wildcard ~*AB* will match strings that do not contain AB).
[...]	Matches any character enclosed in parentheses (for example, [AB]C matches AC and BC).
[~...]	Matches any non-bracketed character (for example, [~AB]C matches XC but not AC).
-	Matches any character in the specified range (for example, [A-G]C matches AC, BC, ..., GC, but not HC).



'	Performs an exact read of subsequent characters (for example, '*AB matches *AB).
---	--

Below there is a table with examples of description key codes containing the most commonly used wildcard characters:

Code	Description
<b>T#</b>	Matches descriptions consisting of T character followed by a digit (i.e., T1, T2, ..., T9).
<b>STA#</b>	Matches descriptions consisting of the string STA followed by a digit (i.e., STA1, STA2, ..., STA9). This pattern does not match the STA string because it is not followed by a digit.
<b>T##</b>	Matches descriptions consisting of T character followed by two digits (ie, T01, ..., T99).
<b>1@</b>	Matches descriptions consisting of 1 digit and a letter (for example, 1A, 1B and 1C). This pattern does not match 1 because it is not followed by a letter.
<b>T.</b>	Matches descriptions that consist T character followed by a character that is not a letter or number (for example, T- and T+).
<b>T*</b>	Matches descriptions consisting of T character followed by an arbitrary string (for example, T1, TOPO, T-2, and TREE).

### Creating a description key



Command line: **\_\_aec\_create\_desckey**

You can create a new description key by selecting **Create** from the context menu of any description key set in the Drawing Settings **Drawing Settings** section of the **Drawing Explorer**.

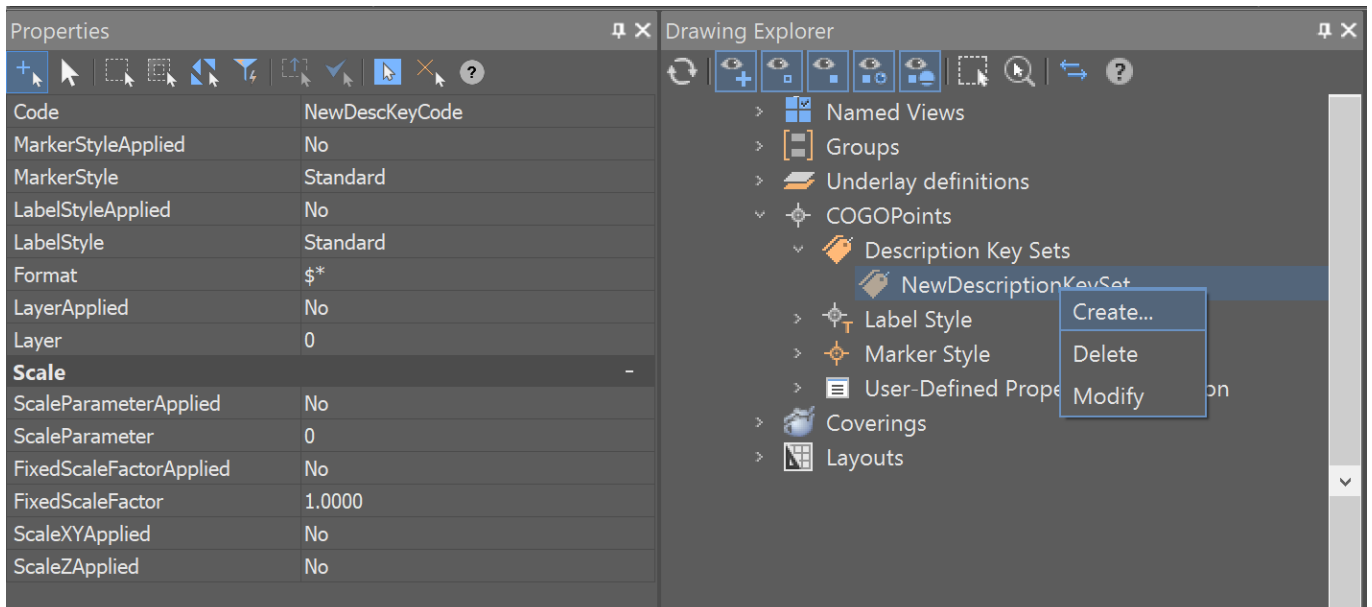

### Options:

<b>Code</b>	This parameter determines which points can be matched to a given description key during description key matching.
<b>MarkerStyle</b>	Specifies the marker style that will be indicated for points.
<b>LabelStyle</b>	Specifies the label style that will be indicated for points that satisfy the description key code.

<b>Format</b>	Specifies the format used to convert the raw description into a full description. Click the cell and enter the format. Enter \$* if you want the full description to match the raw one.
<b>Layer</b>	Used to specify the layer for the point.
<b>ScaleParameter</b>	Defines the position in the raw description of the parameter that contains the value used to scale the point sign when the description key is matched.
<b>FixedScaleFactor</b>	Defines the fixed scale used to scale the point sign when the description key is matched.
<b>ScaleXYApplied</b>	If the description key matches, the scale of the description key will be applied to the X-Y axes passing through the point.
<b>ScaleZApplied</b>	When the descriptive key is matched, the scale of the description key will be applied to the Z axis through the point.

### Deleting a description key



Command line: **\_\_aec\_delete\_desckey**

You can delete a description key by selecting **Delete** from its own context menu in the **Drawing Explorer**.

### Modifying a Description Key



Command line: **\_\_aec\_modify\_desckey**

You can view and modify the description key settings by selecting **Modify** in the context menu of the section **Drawing Settings – COGOPoints – Name of the Description Key** in the **Drawing Explorer**. Next, in the **Properties** bar, you can view or modify the settings.

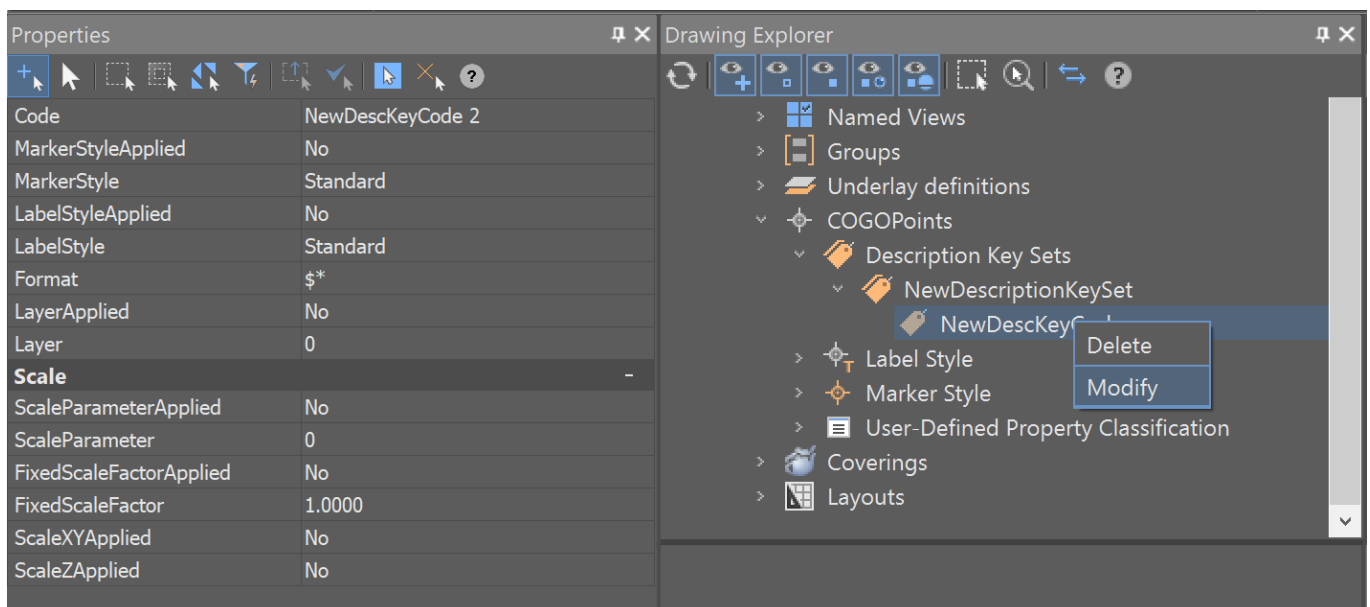

The screenshot displays two panels: 'Properties' on the left and 'Drawing Explorer' on the right. The 'Properties' panel shows the following settings:







- Code: NewDescKeyCode 2
- MarkerStyleApplied: No
- MarkerStyle: Standard
- LabelStyleApplied: No
- LabelStyle: Standard
- Format: \$\*
- LayerApplied: No
- Layer: 0
- Scale** (Section Header)
- ScaleParameterApplied: No
- ScaleParameter: 0
- FixedScaleFactorApplied: No
- FixedScaleFactor: 1.0000
- ScaleXYApplied: No
- ScaleZApplied: No

The 'Drawing Explorer' panel shows a tree view with the following structure:

- > Named Views
- > Groups
- > Underlay definitions
- > COGOPoints
  - > Description Key Sets
    - > NewDescriptionKeySet
      - NewDescKey** (Selected)
        - Delete
        - Modify
- > Label Style
- > Marker Style
- > User-Defined Property Classification
- > Coverings
- > Layouts

# Creating surfaces

## Exploding a Cloud into Points

-  Ribbon: **Topoplan – Create TIN** >  **Explode the Cloud into Points**
-  Menu: **Topoplan – Create TIN** >  **Explode the Cloud into Points**
-  Toolbar: **Create TIN** >  **Explode the Cloud into Points**
-  Command line: **NG\_EXPLODE\_POINTCLOUD**

The command allows you to create **Points** or **Geopoints** or **Blocks** objects based on the cloud points for further creation of TIN surface by them (for example, by the [Create TIN by Points](#) command).

Before using the **Explode the Cloud into Points** command, run the [Drawing Units](#) command. In the Insertion scale section, set the value in meters.

The command options are set in the **Properties** toolbar.

### Options:

<b>Result type</b>	Objects to be created based on the cloud points: <b>Points, COGOPoints, Blocks.</b>
<b>Delete source</b>	If <b>Yes</b> is selected – the source point cloud will be deleted after the split is completed. <b>No</b> – the source point cloud remains in the drawing.
<b>Use class</b>	If the cloud has been previously classified, it is possible to get only points of the specified class after splitting.

### Command prompts:

Apply changes? <Yes> or [Yes/No]:

Yes – split into points will be made with the current settings.

No – if the settings have been changed, they are not saved. Split into points will be made with the settings displayed immediately after starting the command.

Then the **Explode** dialog box appears.

Explode

**▼ Drawing objects**

Simple Point    0    By Layer

Text style    Standard

Name    0    T    By Layer

Elevation    0    T    By Layer

Code    0    T    By Layer

Current profile:

Default    +    -

Ok    Cancel

If a Geopoint object is selected, the layers will be locked.

Explode

**▼ Drawing objects**

COGO Point         

Text style      

COGO point group    All Points

Name       T      

Elevation       T      

Code       T      

Current profile:

Default    +    -

Ok    Cancel

**Options:**

**Drawing objects**

The section defines what components will be displayed for points on the screen: **Marker**, **Name**, **Elevation** (Z-coordinate), **Code** (point description). Each component can be assigned its own layer, color, and signatures - a font. The **Select font** dialog allows you to change the name, style and height. Or use a font from the drawing text style.

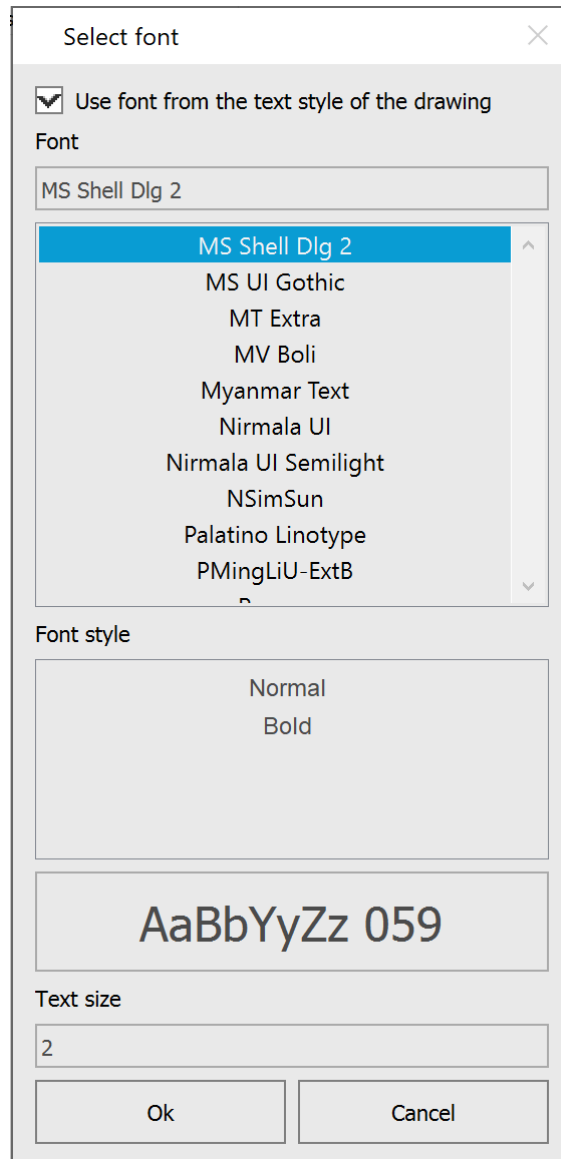

You can also specify the text style for the **Marker**.



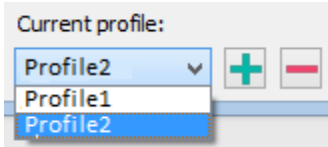





<b>Current profile</b>	<p>Allows you to save all the settings made in the dialog to a profile for later use.</p> 
------------------------	---

When splitting, a group with a name corresponding to the name of the cloud is created.

**NOTE:** If a cloud being broken has more than 100000 points, the process may take a long time .

## Create TIN by Points

-  Ribbon: **Topoplan – Create TIN >  Create TIN by Points**
-  Menu: **Topoplan – Create TIN >  Create TIN by Points**
-  Toolbar: **Create TIN >  Create TIN by Points**
-  Command line: **NG\_CREATE\_TIN**

The command creates a TIN (Triangular Irregular Network) surface – an irregular triangulation network by point objects represented by **Points**, **Geopoints** or **Blocks**. The following objects can be created: **SubMesh**, **Polyface mesh**, **Solids** or **3D Faces**.

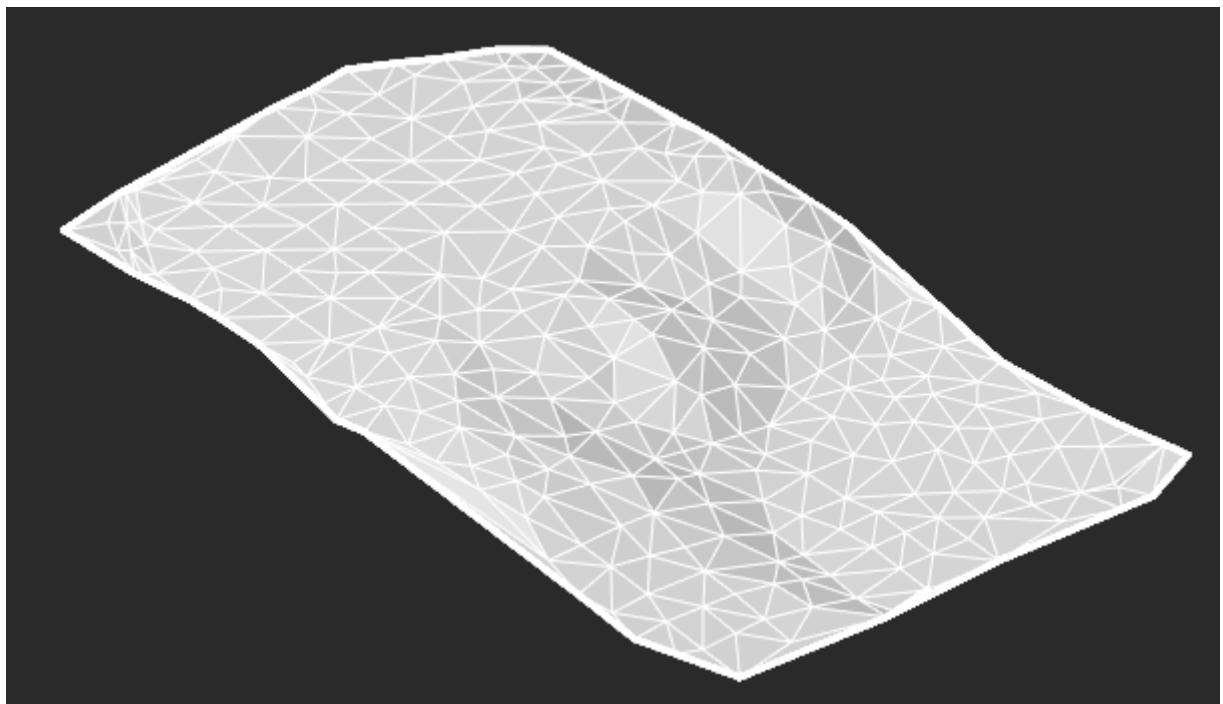

A set of points for creating a mesh can be obtained by importing from third-party formats or from a point cloud with the [Explode the Cloud into Points](#) command.

The command options are set on the **Properties** bar.

**Options:**

<p><b>Result type values</b></p>	<p><b>PolyFace mesh</b> – creates an object of <b>Polyface mesh</b> type, the nodes of which can be edited;</p> <p><b>SubMesh</b> – creates an object of <b>SubMesh</b> type without the ability to edit nodes;</p> <p><b>Solids</b> – will create a triangulation model consisting of separate triangle objects of <b>Solid</b> type;</p> <p><b>Faces</b> – will create a triangulation model consisting of separate triangle objects of <b>3D Face</b> type.</p>
<p><b>Filtrate source points</b></p>	<p>You can change the number of points that will be used to build create triangulation. To do this, select <b>Yes</b> for the <b>Filtrate source point</b> option, select the type of filtration for <b>Filter Units</b> parameters and set the desired value in the <b>Filter range</b> field. This will create a mesh with fewer number of larger triangles. This accelerates the process of creating a triangulation model. The created model will be less accurate, but its further processing will take less time.</p> <p>The following filtration types are possible:</p> <ul style="list-style-type: none"> <li>• <b>Points number</b> – the number of points to be used to create a triangulation model. The total number of points can be determined by selectin all objects of <b>Point</b> (or <b>Geopoint, Block</b>) type by which triangulation will be created.</li> <li>• <b>Percent of points number</b> – the percent of points that will be used to create a triangulation model. It is convenient to use when you know the minimum percentage of points that allows you to build a mesh of acceptable quality;</li> <li>• <b>Maximum error</b> – the maximum distance in drawing units from the surface formed by the bulk of points, beyond which points will be excluded from triangulation. It is convenient to use for creating a triangulation mesh over the earth's surface, automatically filtering out other objects: noises, trees, constructions, etc.</li> </ul>
<p><b>Build boundary from convex hull</b></p>	<p>When this option is enabled, after creating the triangulation the mesh will be processed. Triangles with an edge length greater than the specified one will be removed. The length value is specified in the Max edge field. The length is specified as a percentage of the maximum edge units of the face in a triangulation model or in drawing units (based on the value of <b>Max edge units</b> parameters).</p>
<p><b>Max edge units</b></p>	<p>The length units for the <b>Max edge</b> parameter. Percentage of the units of the maximum face edge in the triangulation model or drawing units (set in the UNITS dialog).</p>
<p><b>Max edge</b></p>	<p>The maximum allowed edge length. All triangles with edges longer than this value will be removed from triangulation. A value of zero disables filtering by edge length.</p> <p>The length is specified as a percentage of the max edge units of the face in the triangulation model or in drawing units (based on the value of the <b>Max edge unit</b>).</p>
<p><b>Min triangle angle</b></p>	<p>The minimum angle in the triangle at which it will not be filtered. A zero value disables filtering by angle value. Triangles are filtered by plan angles, as other filtering options also operate plan length values..</p> <p>This parameter allows you to exclude extended triangles from triangulation. The value is specified in drawing angular units. If the drawing units are set to <b>Degrees-minutes-seconds</b> or <b>Topographic units</b>, the parameter value is measured in degrees.</p>

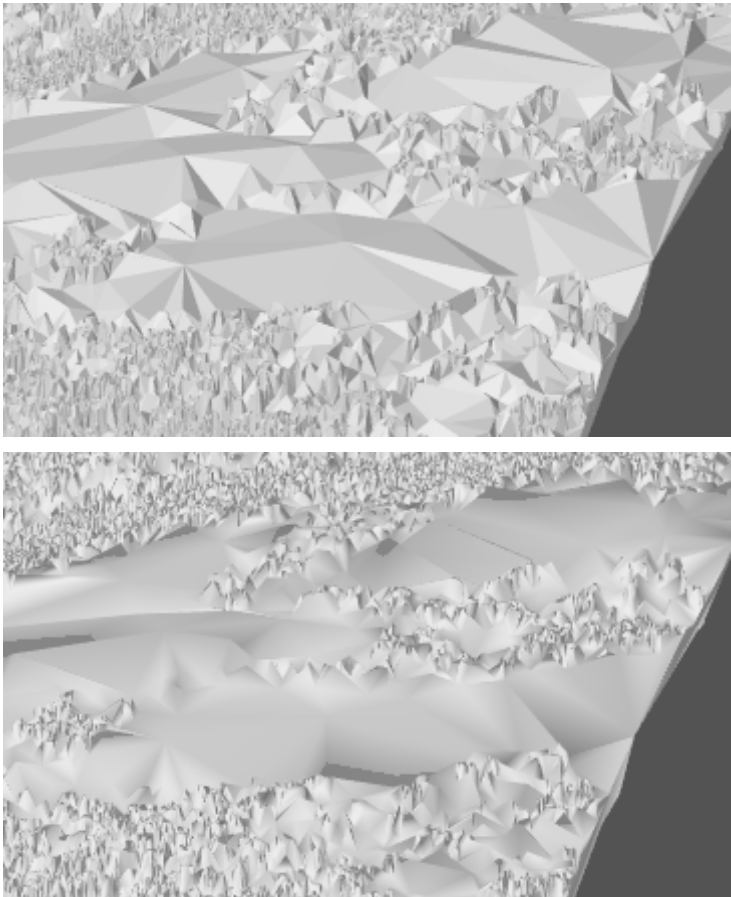
<p><b>Min. triangles</b></p>	<p>The number of triangles that will be removed. When contouring, many small islands are created from several triangles. Islands with fewer triangles than the specified parameter will be removed.</p>
<p><b>Only external boundary</b></p>	<p>This option allows you to apply filtering not to the entire network, but only to triangles on its outer boundary. When this option is enabled, only triangles located on and adjacent to the boundary of the network will be removed during mesh processing</p> <p>Filtering only on the boundary can be useful when, as a result of triangulation, the distant vertices of the mesh boundary are connected by edges, forming parasitic super elongated narrow triangles.</p> 
<p><b>Project points to UCS XY plane</b></p>	<p>When this option is enabled, the triangulation will be created in the XY plane of the user coordinate system. When the option is disabled, the triangulation will be created in the plane of the current view.</p>
<p><b>Select region</b></p>	<p>It is used when you need to build a model not by all points, but only by a certain part. In this case, click the button to the right of the <b>Region is not selected</b> value and draw a polygonal area within which the triangulation will be created on the point cloud.</p>
<p><b>Generate normals</b></p>	<p>Shading parameter. Calculates normals at the mesh vertices, resulting in a smoother mesh appearance in the Precise view. The option is available only if a mesh is selected as the resulting triangulation object.</p> 

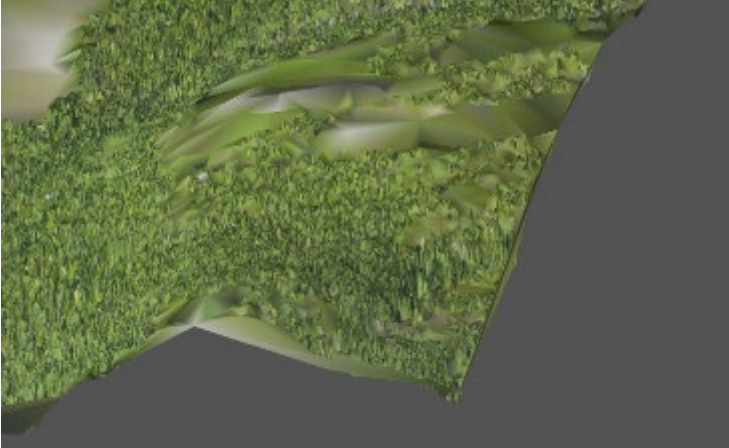

<p><b>Generate per vertex colors</b></p>	<p>Colors the faces and vertices of the mesh according to the points color. The option is available only if a mesh is selected as the resulting triangulation object.</p> 
<p><b>Break for optimization</b></p>	<p>If the triangulation model turns out to be very detailed (millions of faces), then for the possibility of further convenient work, it will be divided into several meshes. If the parameter is disabled, the model will not be split, a single mesh will be created.</p>
<p><b>Filter by layer</b></p>	<p>The possibility to create a surface only by objects of a certain layer. When you select <b>Yes</b> in the drop-down list, it is necessary to specify the layer.</p>
<p><b>Create layer</b></p>	<p>When you select <b>Yes</b>, the mesh will be created on a new layer <b>TIN surface</b>.</p>
<p><b>Use Z coordinate from</b></p>	<p>The option is available if the TIN is based on geopoints. Specifies where to take the coordinate of the TIN vertices along the Z axis. Allows you to take the value from the point elevation (z-coordinate) or any custom attribute of the geopoint of the corresponding format, if any. A custom parameter appears in the replacement list only if all selected geopoints have a numeric value for this parameter.</p>

**Command prompts:**

Apply changes? <Yes>  
or [Yes/No]:

Yes – the command will be performed taking into account changes in settings made by the user in the current command session.







.

No – the command will be performed with the settings that displayed right after the command started.

Save – saving settings to the document.

saveDefault – saving settings to the register.

## Importing Elevation Grid

-  Ribbon: **Topoplan – Create TIN** >  **Import elevation grid**
-  Menu: **Ground – Creating TIN** >  **Import elevation grid**
-  Toolbar: **Creating TIN** >  **Import elevation grid**

 Command line: **NG\_IMPORT\_ELEVATIONGRID**

To create surfaces in the module it is possible to load elevation grid files in PGM, GRD, ASC, DEM formats. As a result of the import, a surface is created in the form of a **Mesh** object.

After starting the command, a standard file selection dialog box will open. It is necessary to specify the file and click **OK**. The import dialog will open:

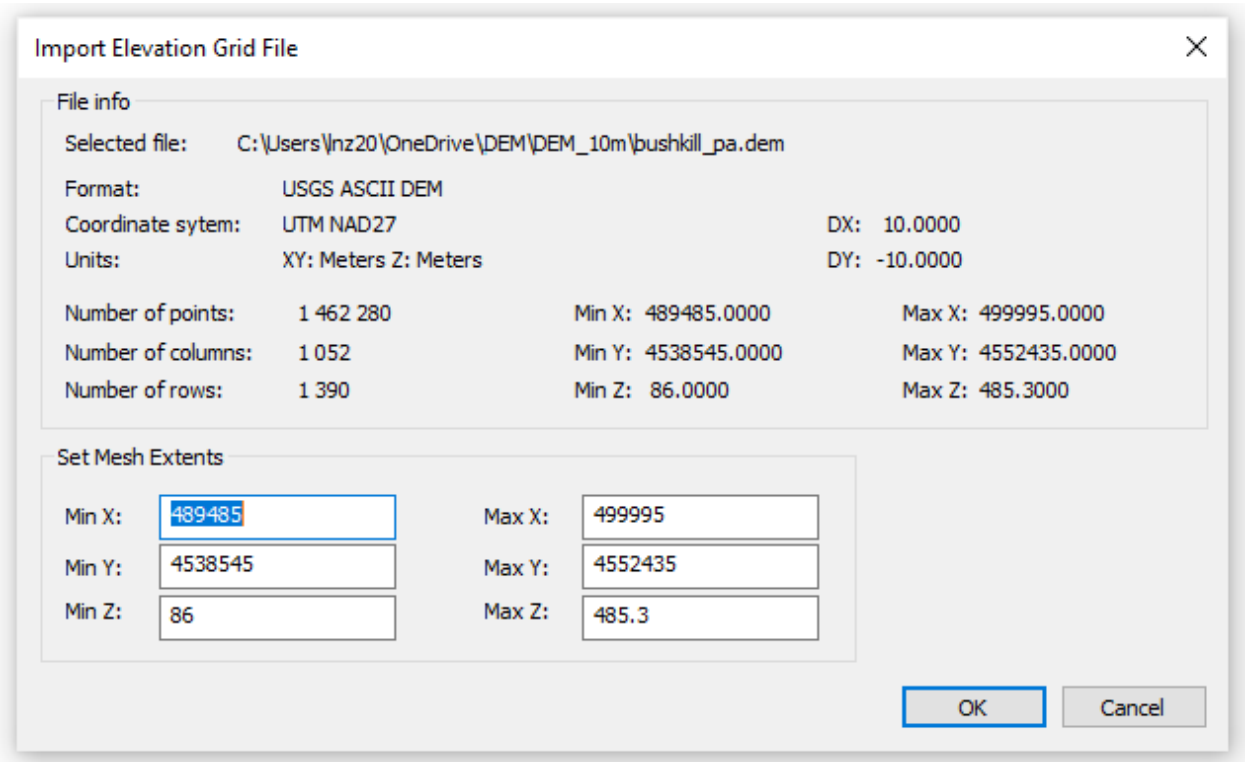

The command options are set in the **Properties** bar.

**Options:**

<b>Split mesh for optimization</b>	If this option is enabled, for more convenient work the mesh will be split into several smaller objects. It is recommended to enable this option.
<b>Convert to CS</b>	If the elevation matrix was created in WGS-84 system, then its conversion is required to display in a drawing's rectangular coordinate system. Possible variants: <b>UTM</b> (Universal Transverse Mercator), <b>CK-42</b> , <b>CK-95</b> . Also, it is possible <b>Do not convert</b> the elevation matrix, but it is recommended not to use this option.

In case the command is performed successfully, the message will appear:





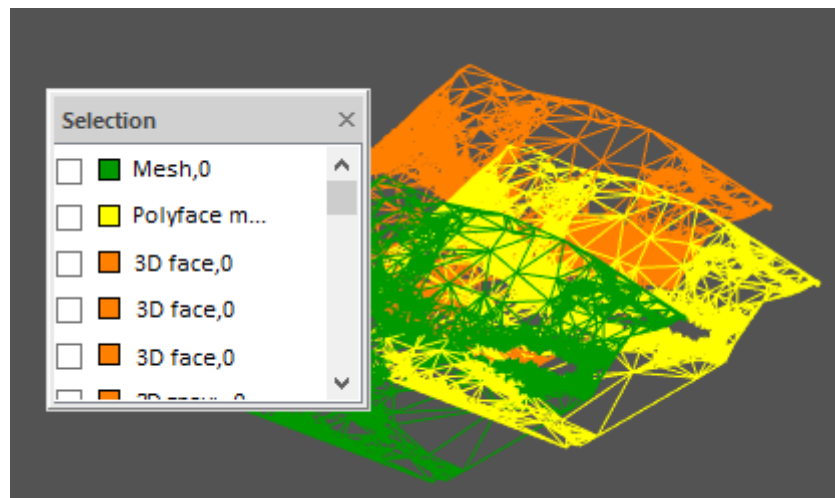
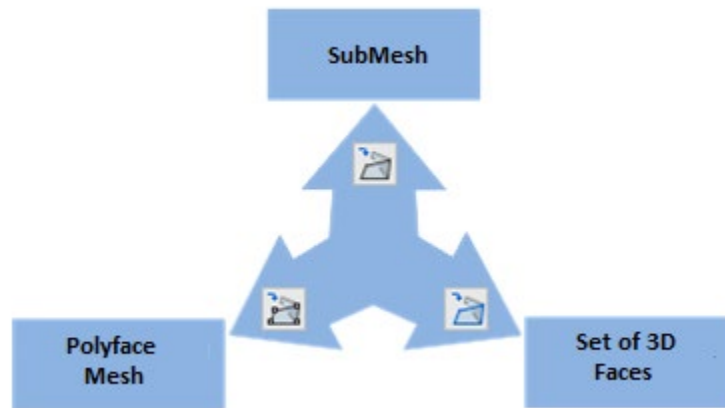

Import evaluation grid done!

## Converting to Meshes or 3D Faces

There is a set of commands for changing the type of triangulation model created by such commands as **Create TIN by Points**. The type of created model can be converted to **SubMesh** (SubDMesh), **Polyface Mesh** (PolyFaceMesh) or a set of **3D Faces**.



## Converting Model to 3D Faces

-  Ribbon: **Topoplan – Create TIN** >  **Converting to 3D Faces**
-  Menu: **Ground – Creating TIN** >  **Converting to 3D Faces**
-  Toolbar: **Creating TIN** >  **Converting to 3D Faces**
-  Command line: **NG\_TO\_3DFACE**

The command converts an object of **SubMesh** or **Polyface mesh** type to a set of **3D Face** type objects.

## Converting Model to SubMesh

-  Ribbon: **Topoplan – Create TIN** >  **Convert to Mesh**
-  Menu: **Ground – Create TIN** >  **Convert to Mesh**
-  Toolbar: **Create TIN** >  **Convert to Mesh**

 Command line: **NG\_TO\_SUBDMESH**

The command converts a set of **3D Face** or **Polyface Meshes** type objects to one or several **Submesh** type object.

**Command prompts:**

Apply changes? Yes – conversion will be performed with the current settings.  
 <Yes> or No – if the settings have been changed, they will not be preserved.  
 [Yes/No]: Conversion will be performed with the settings that displayed right after the command started.

The command options are set in the **Properties** bar.

**Options:**

<b>Split mesh for optimization</b>	<b>Yes</b> (recommended) – the SubMesh obtained from the selected objects will be exploded to several smaller meshes for further comfortable work. The explosion criteria are set by the <b>Split meshes by topology</b> option. <b>No</b> – a single mesh will be created from the selected objects without splitting to parts.
<b>Split meshes by topology</b>	A method of exploding a mesh into smaller meshes: <ul style="list-style-type: none"> <li>• <b>Yes</b> – split a mesh into parts taking into account both topology (<b>Maximum difference of normals in mesh</b> option), and limitations (no more than 500000 faces).</li> <li>• <b>No</b> – split only on the basis of limitations (no more than 500000 faces).</li> </ul>
<b>Maximum difference of normals in mesh (degrees)</b>	The maximum allowable deviation of the normal of a mesh element from its average normal (in degrees), at which the element will be considered to belong to this mesh. The normals of elements in each part, into which a single mesh will be split, should not differ by more than a given value. The option determines the number of pieces into which the mesh will be split, if the <b>Split meshes by topology</b> option is set to <b>Yes</b> .
<b>Vertex tolerance</b>	Accuracy parameter within which closely located nodes (vertices) of objects will be combined during conversion. For example, the vertices of neighboring faces may not match within 1e-0.4, but with the <b>Vertex tolerance</b> value equal to 1e-0.2 such vertices will be merged into one.

## Converting Model to Polyface Mesh

 Ribbon: **Topoplan – Create TIN** >  **Converting to POLYFACEMESH**

 Menu: **Ground – Creating TIN** >  **Converting to POLYFACEMESH**

 Toolbar: **Creating TIN** >  **Converting to POLYFACEMESH**

 Command line: **NG\_TO\_POLYFACEMESH**

The command converts a set of **3D Face** or **SubMesh** type objects to one or several **Polyface mesh** type objects.

**Command prompts:**

Apply changes? Yes – conversion will be performed with the current settings.  
 <Yes> or No – if the settings have been changed, they will not be preserved.  
 [Yes/No]: Conversion will be performed with the settings that displayed right after the command started.

The command options are set in the **Properties** bar.

**Options:**

<b>Split meshes by topology</b>	A method of exploding a mesh into smaller meshes: <ul style="list-style-type: none"> <li>• <b>Yes</b> – split a mesh into parts taking into account both topology (<b>Maximum difference of normals in mesh</b> option), and limitations (no more than 32767 faces and vertices).</li> <li>• <b>No</b> – split only on the basis of limitations (no more than 32767 faces and vertices).</li> </ul>
<b>Maximum difference of normals in mesh (degrees)</b>	The maximum allowable deviation of the normal of a mesh element from its average normal (in degrees), at which the element will be considered to belong to this mesh. The normals of elements in each part, into which a single mesh will be split, should not differ by more than a given value. The option determines the number of pieces into which the mesh will be split, if the <b>Split meshes by topology</b> option is set to <b>Yes</b> .
<b>Vertex tolerance</b>	Accuracy parameter within which closely located nodes (vertices) of objects will be combined during conversion. For example, the vertices of neighboring faces may not match within 1e-0.4, but with the <b>Vertex tolerance</b> value equal to 1e-0.2 such vertices will be merged into one.

## Tools to Work with Surfaces

The surfaces are automatically created according to the Delaunay triangulation rules. Therefore, after creating a TIN, it is often required to edit some areas. Also, in the process of working with relief, sometimes the task of clarifying the surface arises. To do this, the surface editing functionality is used.

To work with surface editing commands, it is recommended to enable shaded visual styles: **3D Flat-shaded with edges, 3D Gouraud-shaded with edges**.

### Simplifying the Mesh



Ribbon: **Topoplan – Modify TIN** >  **Simplifying the Mesh**



Menu: **Topoplan – Modify TIN** >  **Simplifying Mesh**

 Toolbar: **Modify TIN** >  **Simplifying the Mesh**

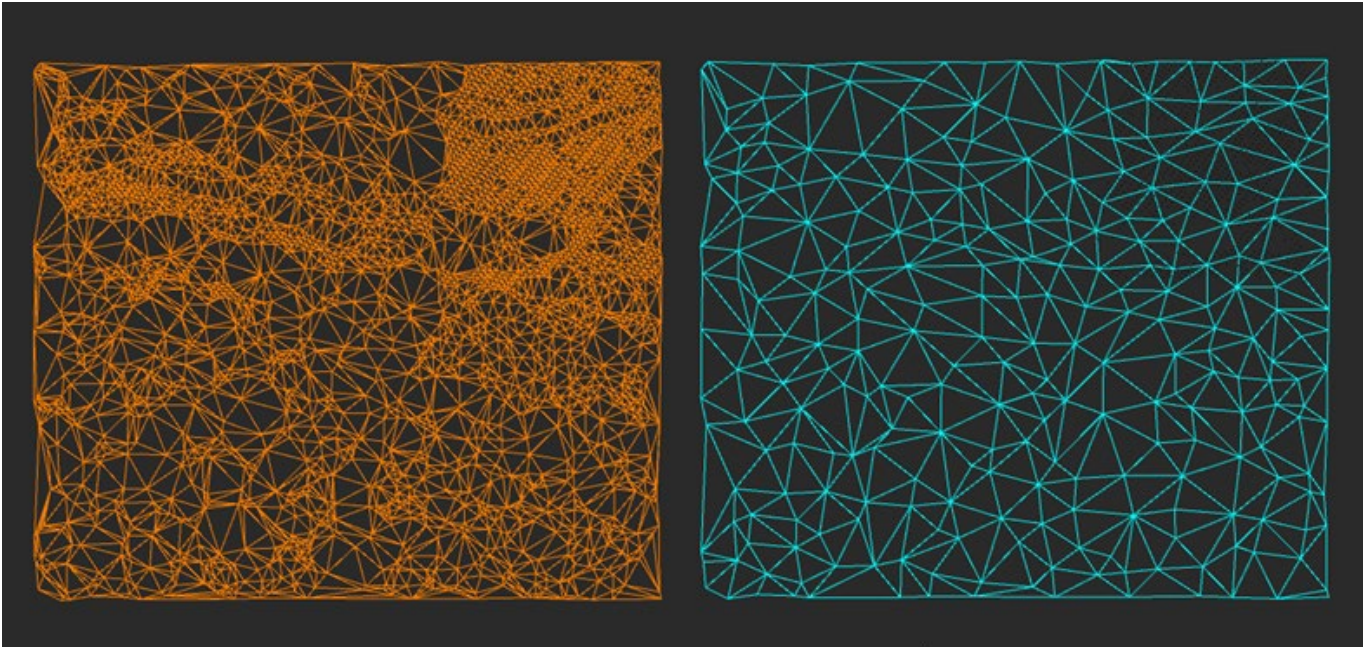

 Command line: **NG\_SIMPLIFY**

The **Simplifying the Mesh** command performs triangulation network optimization. The optimization goal is to obtain a more sparse mesh that retains its form.

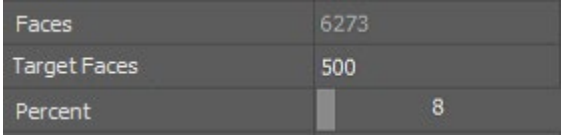
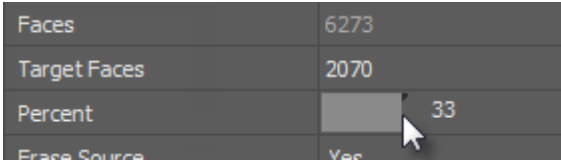

The command options are set in the **Properties** bar.

**Options:**

<b>Target (faces)</b>	Number of faces in the optimized mesh.
<b>Percent</b>	<p>Percentage of the number of edges in the optimized network compared to the original number of edges.</p>  <p>The right edge of the slider can be moved, changing the percentage and number of target faces along with it.</p> 
<b>Erase Source</b>	Delete the source mesh or not.

<b>Boundary Weight</b>	<p>The coefficient that determines the degree of identity of the edge before and after mesh simplification.</p> <p>The parameter values range from 0 to the infinity. The more the value is, the more detailed the mesh will be on its boundaries, and the less will be the deviation of edge of the optimized mesh from its previous position. When the value = 0, the mesh boundary looks "ragged", the mesh edge is rough. Too large value would lead to excessive detailing of the mesh edge and increased optimization time.</p> <p>Optimal value = 1.</p>
<b>Preserve Topology</b>	<p>Allows you to create a mesh without self-intersections of faces, which may occur as a result of its optimization. The parameter value should always be Yes.</p>
<b>Generate Normals</b>	<p>Whether to create vertex-by-vertex normals. It is used for improved display of a mesh.</p> <p>The default value is Yes.</p>
<b>Face Quality</b>	<p>Whether to strive to create a mesh with faces close to equilateral triangles.</p> <p>When the option is disabled, narrow faces with very long edges can be created.</p> <p>The default value is Yes.</p>
<b>Ignore Texture</b>	<p>Optimizes a mesh without saving its texture, if any. The default value is Yes.</p> <p>In most cases the option should be enabled, i.e. a mesh should be optimized without saving its texture. In this case the existing texture will be distorted, therefore, at the end of optimization, to re-overlay texture use the <b>Texture Atlas Overlay</b> command.</p> <p>Optimization in the texture saving mode is performed with less quality, than in ignoring mode. It makes sense to optimize a mesh with saving texture in such rare cases, when you need to have texture on the mesh, but it is not possible to restore the texture by point cloud (for example, there is no point cloud by which the mesh was created).</p>

## Adding an Edge

 Ribbon: **Topoplan – Modify TIN** >  **Add Mesh Edge**

 Menu: **Topoplan – Modify TIN** >  **Add Mesh Edge**

 Toolbar: **Modify TIN** >  **Add Mesh Edge**

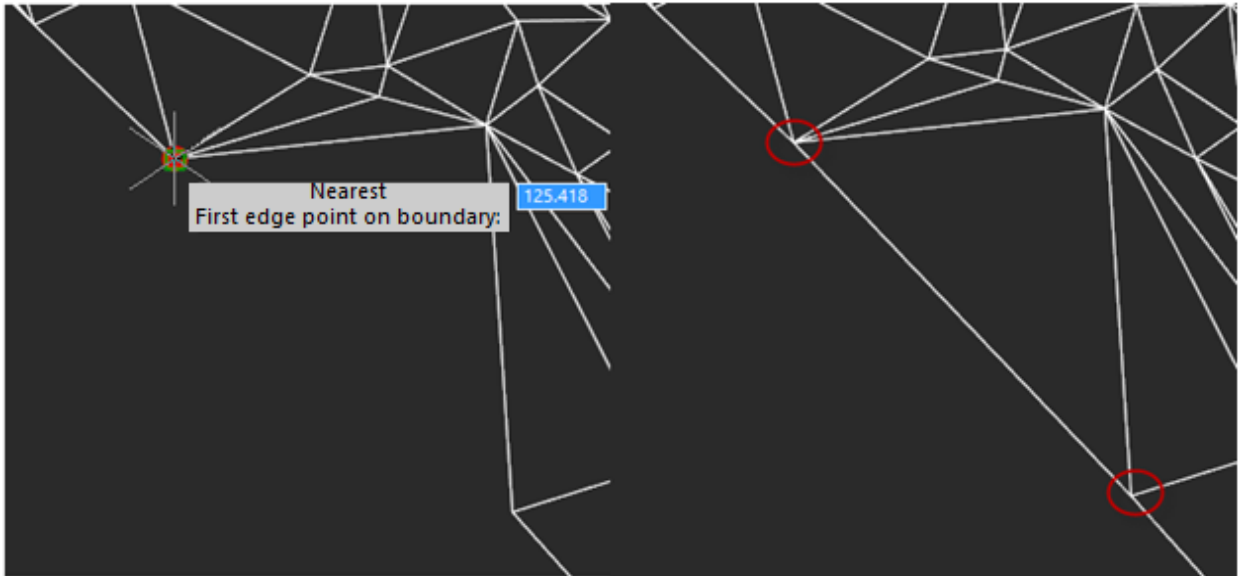

 Command line: **NG\_MESH\_EDGE\_ADD**

The command adds a new edge to an existing surface (SubMesh or Polyface Mesh) at its boundary. An edge can only be added on a non-convex boundary (inner or outer) so that a new triangular face can be created without disturbing the 2.5D mesh.



The position of several faces can be successively changed. Pressing the **ESC** button closes the command.

## Flip Edge

-  Ribbon: **Topoplan – Modify TIN** >  **Flip Edge**
-  Menu: **Ground – Editing TIN** >  **Flip edge**
-  Toolbar: **Editing TIN** >  **Flip edge**
-  Command line: **NG\_MESH\_FLIP**

The command changes the edge position between two triangulation faces in the surface model (SubMesh or Polyface mesh); it can be performed, for example, to turn edges along the slope crest, road side, etc.

When you run the command, an object snap is enabled, and then you should specify an edge for a flip.

When you hover the cursor over the mesh, two adjacent triangles the position of face between which will be changed are highlighted in red. A click on the face flips the edge.

**Surface before flip**

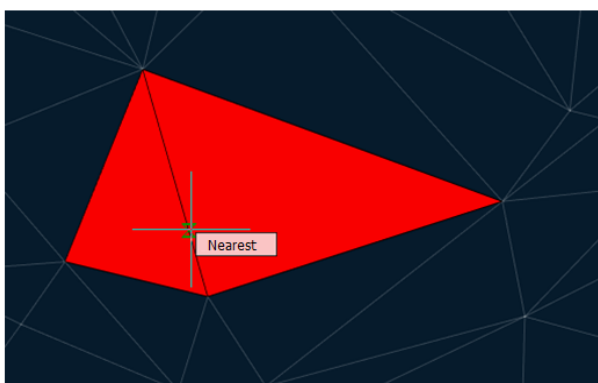

**Surface after flip**

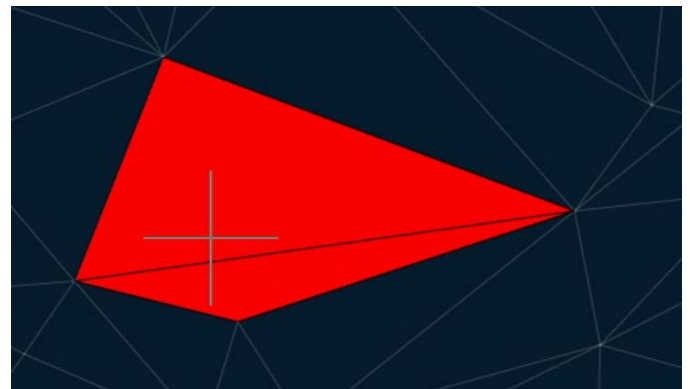

The position of several faces can be subsequently changed. Pressing **ESC** ends the command.



## Deleting an Edge

 Ribbon: **Topoplan – Modify TIN** >  **Delete Edge**

 Menu: **Ground – Editing TIN** >  **Delete Edge**

 Toolbar: **Editing TIN** >  **Delete Edge**

 Command line: **NG\_MESH\_EDGE\_DELETE**

Using the command, you can delete edges of **Submesh** or **Polyface mesh** surface. Usually, it is used to delete “long” edges along the mesh boundary for correct contouring.

**NOTE:** Since a TIN surface has triangle faces, deletion of edges will result in deletion of faces that contained them.

### Command prompts:

Specify  
opposite  
corner or  
[Edge]:

Use the frame to select one or more edges to delete. This command mode is enabled by default.

Edge – when this option is selected, the command switches to the mode of sequential (one at a time) specifying edges to be deleted.

Specify edge  
to delete or  
[Frame]:

Frame – return to selecting edges with a frame.

**Faces that will be deleted when deleting edges**

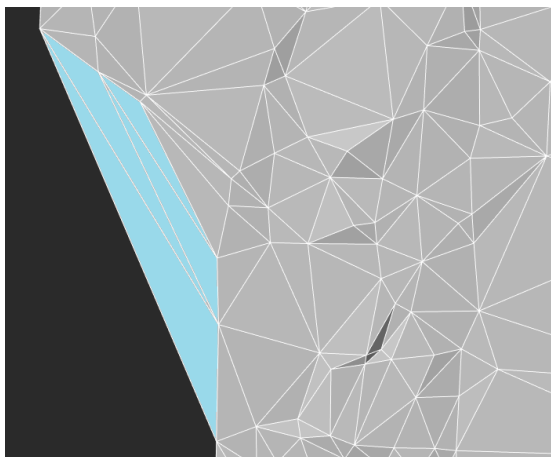

**Surface after deleting edges**



4. Several edges can be deleted in succession. Pressing **ESC** button ends the command.

The command is also used to delete faces inside water reservoirs to exclude the construction of contours along the reservoir.



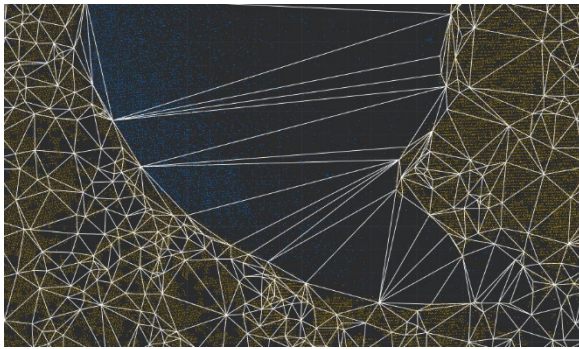

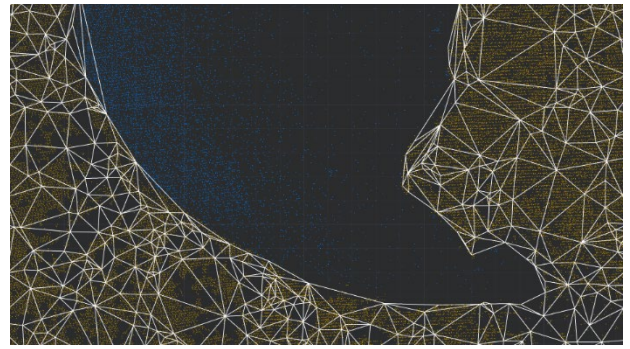

**Faces passing along the water surface**



**Faces are deleted**



## Adding a Vertex

-  Ribbon: **Topoplan – Modify TIN** >  **Add vertex**
-  Menu: **Ground – Editing TIN** >  **Add vertex**
-  Toolbar: **Editing TIN** >  **Add vertex**
-  Command line: **NG\_MESH\_VERTEX\_ADD**

The command adds a new vertex to the existing surface (Submesh or Polyface mesh). The position of the contour lines is also updated if they were built.

### To add a vertex:

1. Set the **Top View**.
2. Run the command.
3. In response to the prompt in the command line, select **Submesh** or **Polyface mesh**:

### Specify new vertex position

4. Click cursor inside a mesh triangle to add a new vertex in the specified place. A vertex can be added with a reference to some objects.
5. Select whether to project the point onto the surface or use its actual height after specifying.

The anchor point elevation is 0.00. The elevation of the point projected onto the surface is 193.62. Specify vertex elevation <193.62> or [Snap/Project]: Project

**Surface before adding a vertex**



**Surface with added vertex**

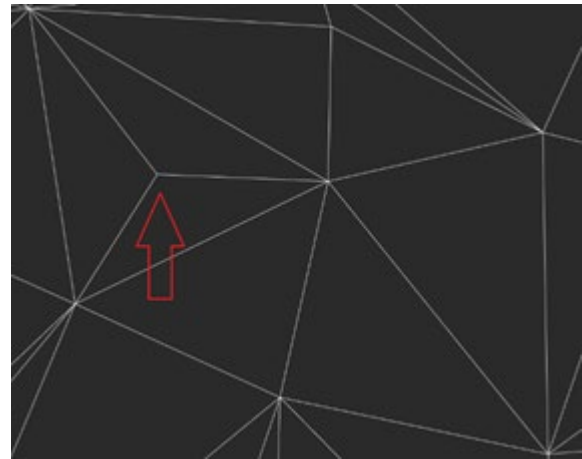

6. Several vertices can be added in succession. Pressing **ESC** button ends the command.

## Deleting a Vertex

 Ribbon: **Topoplan – Modify TIN** >  **Delete Vertex**

 Menu: **Ground – Editing TIN** >  **Delete Vertex**

 Ribbon: **Editing TIN** >  **Delete Vertex**

 Command line: **NG\_MESH\_VERTEX\_DELETE**

The command deletes a vertex from an existing surface (Submesh or Polyface mesh) and rebuilds triangulation. The position of the contour lines is also updated if they were built.

The vertex to be deleted is highlighted in red.

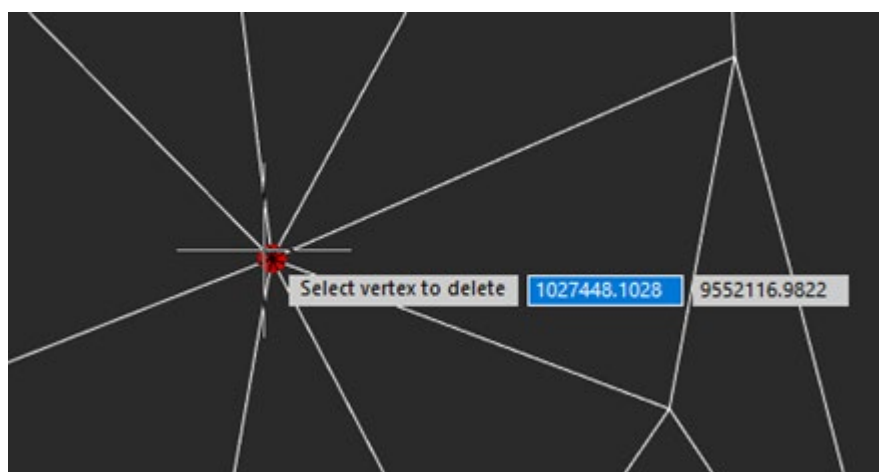

### To delete a vertex:

1. Run the command.
2. In response to the prompt in the command line:

Select vertex to delete

select a vertex. The selected vertex is deleted, and the triangulation mesh is rebuilt.

Select vertex to delete or [Frame]: Frame  
 Specify first corner or [Vertex]:  
 Specify opposite corner or [Vertex]:

Select an area with a frame. The selected vertices will be deleted and the triangulation network will be rebuilt.

```

X NG_MESH_VERTEX_DELETE - Delete Point
Specify first corner or [Vertex]:
Specify opposite corner or [Vertex]:
Specify first corner or [Vertex]: Vertex
Select vertex to delete or [Frame]:
  
```

**Surface before deleting the vertex**



**Surface after deleting the vertex**



- Several vertices can be deleted in succession. Pressing **ESC** button ends the command.

## Changing Elevation

 Ribbon: **Topoplan – Modify TIN** >  **Change Elevation**

 Menu: **Ground – Editing TIN** >  **Change Elevation**

 Toolbar: **Editing TIN** >  **Change Elevation**

 Command line: **NG\_MESH\_VERTEX\_MOVE\_H**

The command changes elevation (Z coordinate) of a node of an existing surface (Submesh or Polyface mesh) and rebuilds triangulation.

### To change elevation:

- Run the command.
- In response to the prompt in the command line:

Select vertex to change elevation

select a vertex. When you hover the cursor over the mesh node, it is highlighted in red.

- After specifying the node, the prompt follows:

Elevation of this vertex is 200.36. Specify new elevation.

where 200.36 value is the node elevation. You need to enter a new elevation in the drawing units and press **ENTER**.

**The surface vertex whose elevation should be changed**

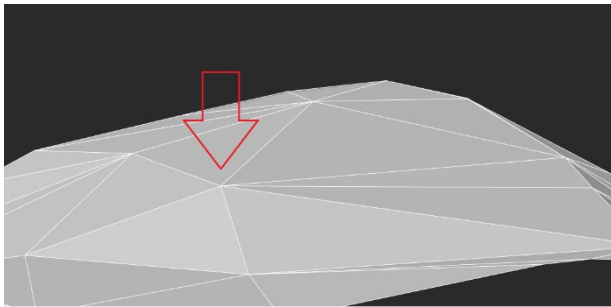

**Surface after changing the vertex elevation**

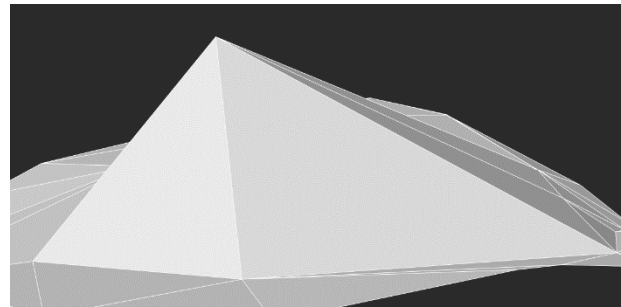

- Elevations of several vertices can be changed in succession. Pressing **ESC** button ends the command.

## Moving a Point

 Ribbon: **Topoplan – Modify TIN** >  **Move Point**

 Menu: **Ground – Editing TIN** >  **Move Point**

 Toolbar: **Editing TIN** >  **Move Point**

 Command line: **NG\_MESH\_VERTEX\_MOVE**

The command moves a point in an existing surface (Submesh or Polyface mesh) and rebuilds the triangulation. The movement takes place in the XY plane.

### To move a point:

- Run the command.

In response to the prompt in the command line

- select a vertex. When you hover the cursor over the mesh node that will be selected for moving, it is highlighted in red.

Select vertex to move

- Click the cursor to add a new point at the specified location. A point can be added with reference to any objects of the situation

Pick new vertex position

- Choose whether to project the point onto the surface or use its actual height after specifying.

Osnapped UCS elevation is 193.01. Mesh UCS elevation is 193.57. Specify vertex UCS elevation <193.57> or [Osnapped/Mesh]:

**Node whose position should be moved**

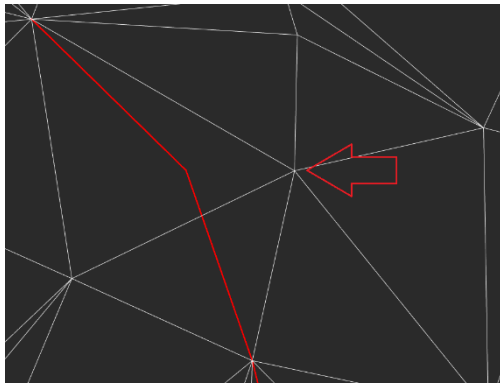

**The node position has been changed**

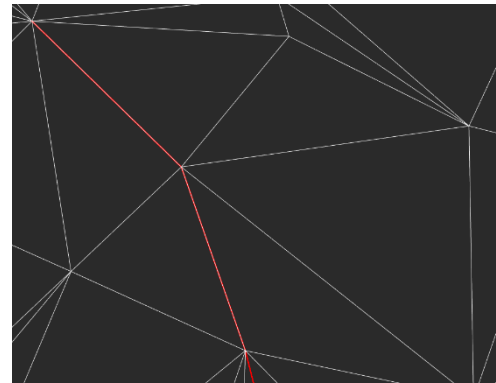

5. Several vertices can be moved in succession. Pressing **ESC** button ends the command.

## Adding Structure Line

 Ribbon: **Topoplan – Modify TIN** >  **Add Structure Line**

 Menu: **Topoplan – Editing TIN** >  **Add Structure Line**

 Toolbar: **Editing TIN** >  **Add Structure Line**

 Command line: **NG\_MESH\_STRUCTURAL\_CREATE**

The command adds a new structure line or a retaining wall to the existing surface.

Structure lines are used to detail relief forms. Such lines can describe lines of curbs, pavement boundaries, gulleys, watersheds, etc. When there are structure lines present, the surface triangulation is forced along the structure line; triangulation edges cannot intersect a structure line. Types of objects that can be added as structure lines: **lines, polylines, 3D polylines**.

The command supports multiple selection.

The command options are set in the **Properties** bar.

### Options:

<b>Structural type</b>	Type of structure line: <b>Standard</b> or <b>Retaining wall</b> .
<b>Project profile on</b>	<p>The parameter is used for the standard structure line.</p> <ul style="list-style-type: none"> <li>• <b>WCS</b> – the polyline will be projected onto the XY plane of the world coordinate system;</li> <li>• <b>UCS</b> – the polyline will be projected onto the XY plane of the custom SC;</li> <li>• <b>Viewport</b> – the polyline will be projected onto the viewport plane.</li> </ul>

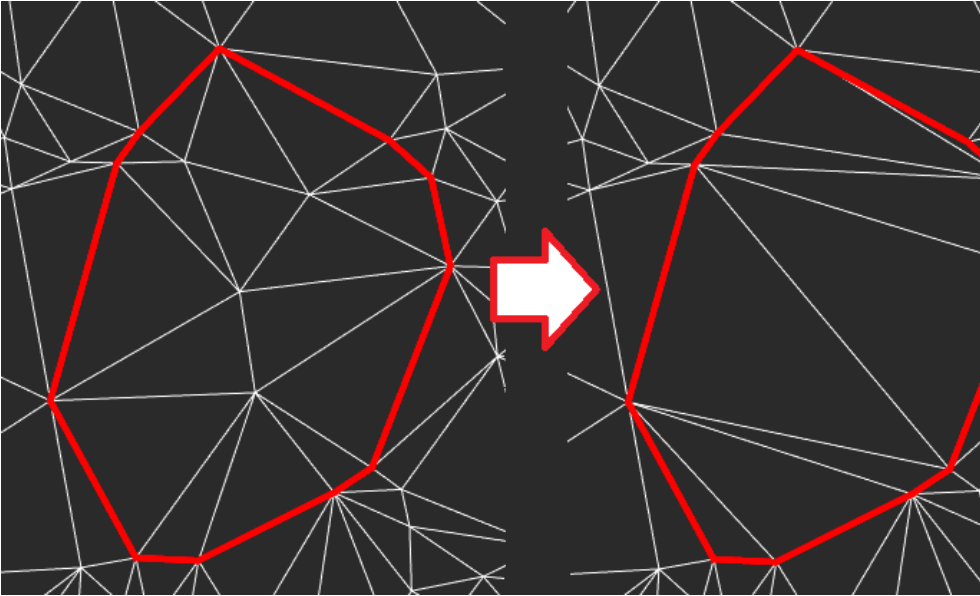
<p><b>Get Elevation from</b></p>	<p>The parameter is used for the retaining wall. Specify the source of marks:</p> <ul style="list-style-type: none"> <li>• <b>Structural Line</b> – marks will be taken from the line specified when drawing. To obtain a polyline with surface elevations, you can use the <a href="#">Draw structure line</a> or <a href="#">Project line to mesh</a>.</li> <li>• <b>Surface</b> – the command will project a line onto a surface and take marks from the surface.</li> </ul>
<p><b>Set Wall Height</b></p>	<p>A method to specify the height of the retaining wall:</p> <ul style="list-style-type: none"> <li>• <b>Separately</b> – during construction, the height of the wall for each vertex of the line will be requested.</li> <li>• <b>Common</b> – constant height, defined by the <b>Common Wall Height</b> parameter.</li> </ul>
<p><b>Common Wall Height</b></p>	<p>Uniform wall height for the case when the <b>Set Wall Height</b> – <b>Common</b>. The height can be positive or negative.</p>
<p><b>Type of work (for closed contours)</b></p>	<p>The parameter is available if a closed polyline is selected:</p> <ul style="list-style-type: none"> <li>• <b>Saving internal points</b> – surface points that fall inside the closed line will be saved.</li> <li>• <b>Removing internal points</b> – surface points that fall inside the closed line will be removed, and the surface will be rebuilt.</li> </ul> 

**To add a structure line:**

1. Run the command.
2. Set the parameters in the **Properties** bar. The **Structural type** should have the **Standard** value. Press **ENTER** in response to the prompt in the command line:

Apply changes? <Yes> or [Yes/No]:

3. In response to the prompt

Select polyline or line to be added as structural line or [?]:

specify a line, polyline or 3d polyline. After selecting an object by the cursor, triangulation will be rebuilt.

**Surface before adding a structure line**

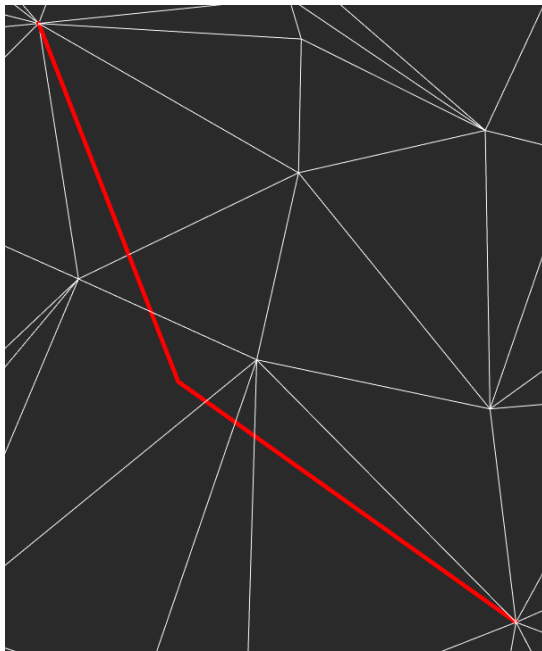

**Surface after adding a structure line**

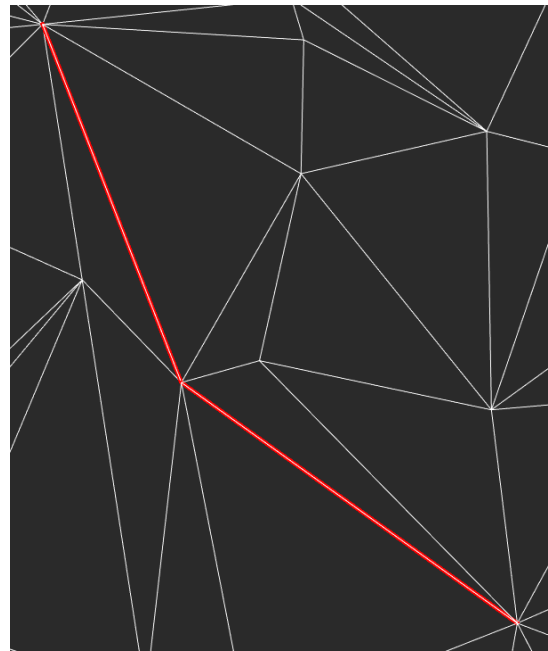

**To add a Retaining wall structure line:**

Run the command.

Configure the parameters in the **Properties** bar. The **Structure type** should have the **Retaining will** value. Press **ENTER** in response to the prompt in the command line:

Apply changes? <Yes> or [Yes/No]:

In response to the prompt

Select polyline or line to be added as a structural line or [?]:

specify a line, polyline or 3d polyline.

In response to the prompt

Specify the side of the wall offset:

specify the slope side.

If the **Set the wall height** parameter was set to **Separate vertices**, then specify the wall height for each line vertex. The current vertex is indicated by a red circle.

The mesh triangulation will be rebuilt. The retaining wall is always vertical in the World coordinate system.



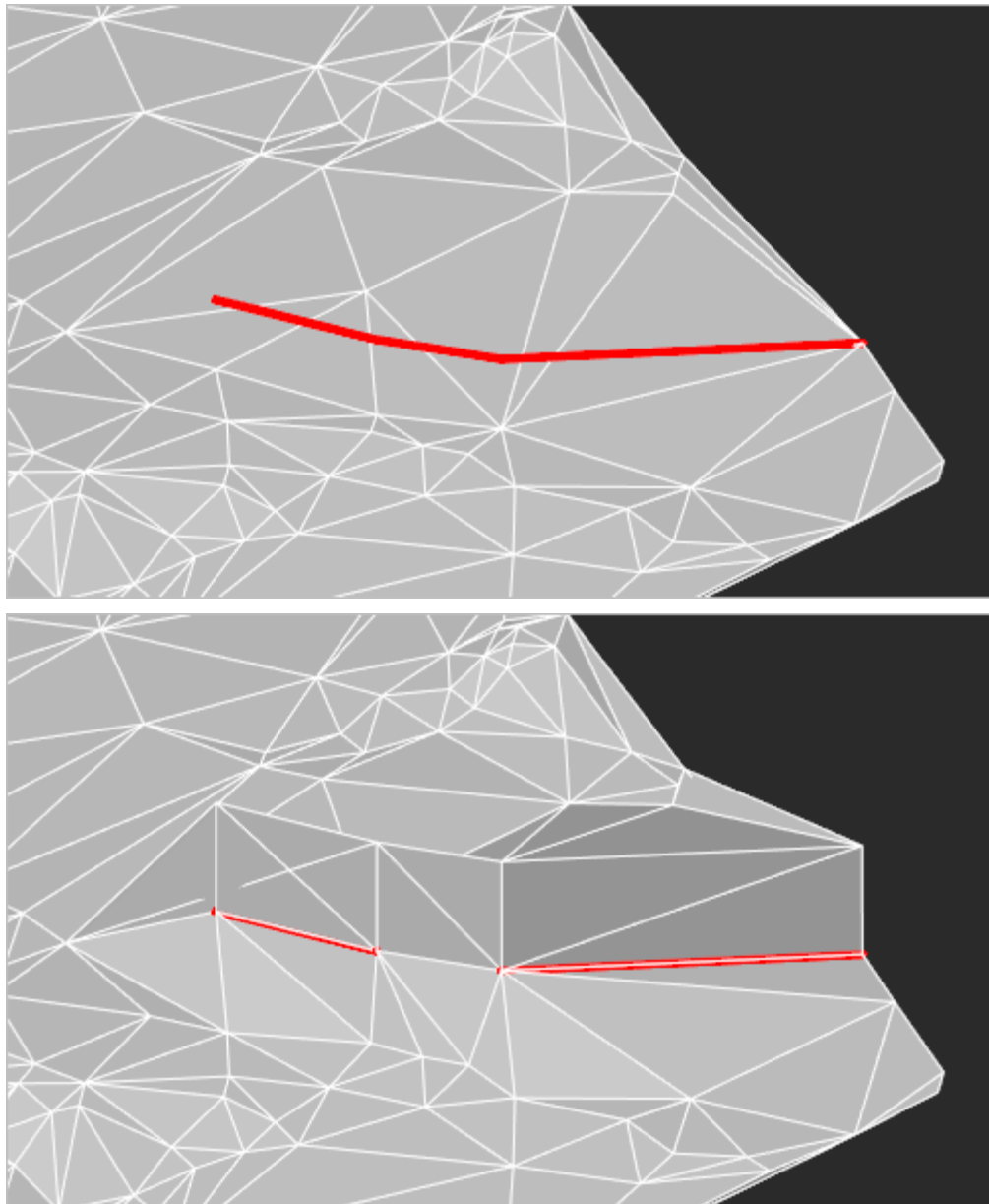

The command supports multiple selection.

## *Mesh Sealing Holes*



Ribbon: **Topoplan – Modify TIN** >  **Mesh Seal Holes**



Menu: **Topoplan – Modify TIN** >  **Mesh Seal Holes**



Toolbar: **Modify TIN** >  **Mesh Seal Holes**



Command line: **NG\_MESH\_SEAL\_HOLES**

If during the creation of a TIN surface or in the process of its editing surface holes were formed, the command allows filling them with missing faces by specifying an edge on the hole boundary.

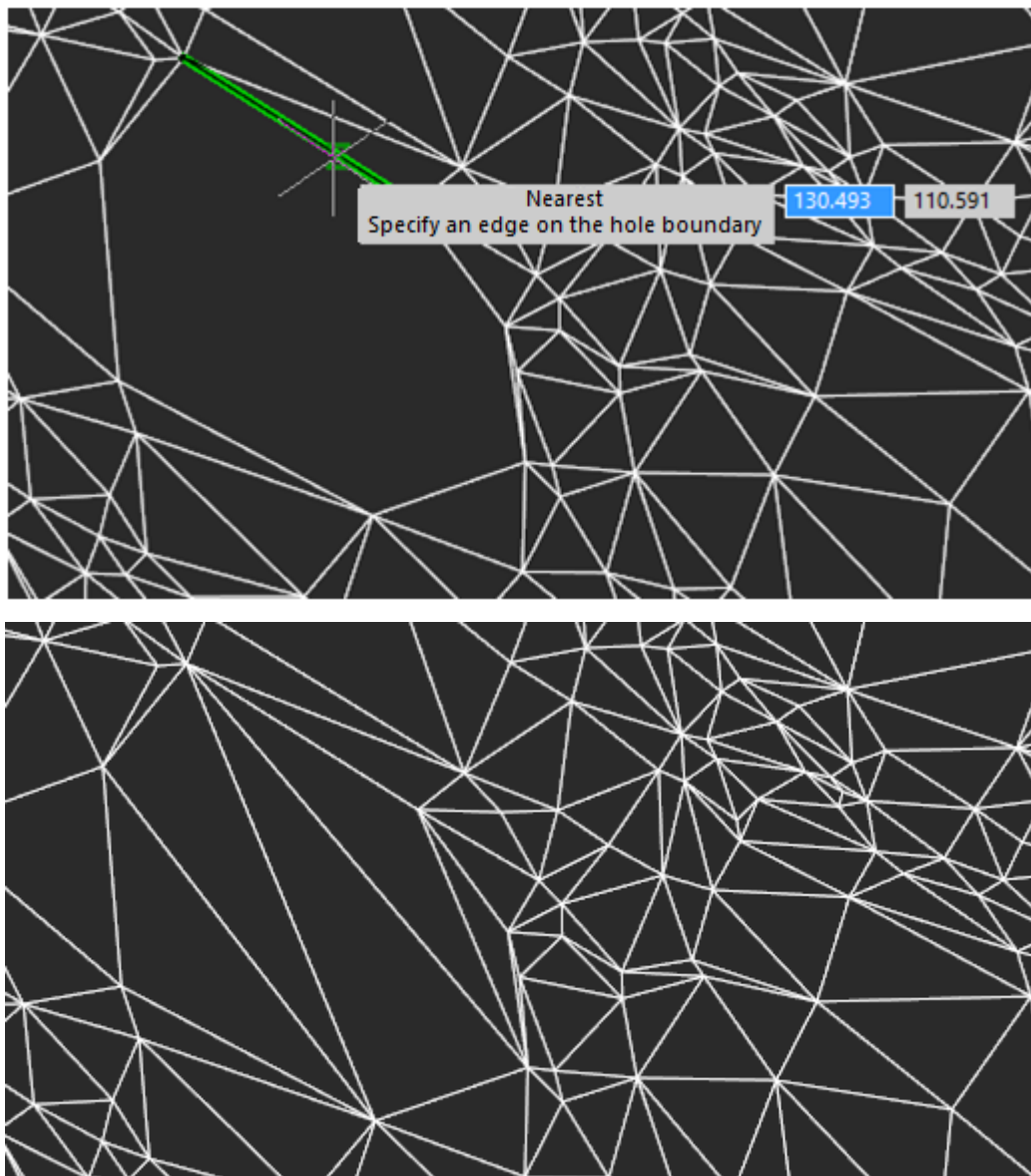

## Mesh Boundary

 Ribbon: **Topoplan – Modify TIN** >  **Boundary Mesh**

 Menu: **Ground – Editing TIN** >  **Boundary Mesh**

 Toolbar: **Editing TIN** >  **Boundary Mesh**

 Command line: **NG\_MESH\_BOUNDARY**

The command purpose is to remove faces with edges of a certain length, which can prevent from the correct construction of contours.

### Preliminary actions

Before running the command it is necessary to define the length of edges. Measurement can be performed by the **Distance between points** (DIST) command. To do this, run the command

with the enabled **ENDpoint** snap and make measurement. In this case, the obtained distance values will be displayed in the **Properties** toolbar:

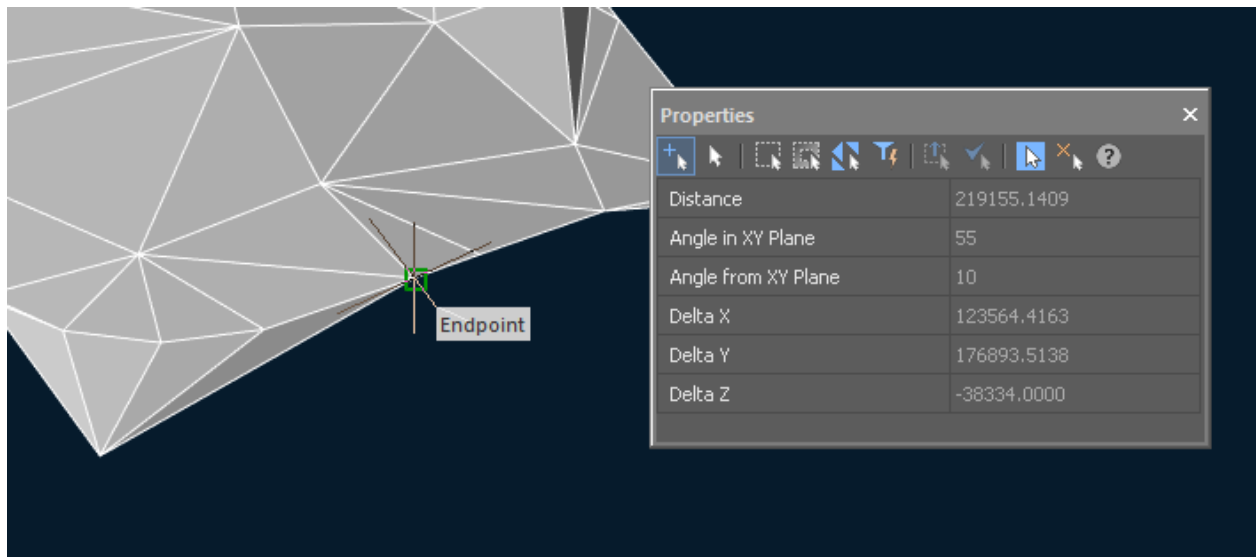

### Mesh Boundary

The command options are set on the **Properties** bar.

#### Options:

<b>Only external boundary</b>	<b>Yes</b> – changes will only affect the outer triangles. When you specify <b>No</b> , triangles inside a mesh can be changed.
<b>Maximum edge length</b>	It is necessary to specify a value slightly less than that measured by the <b>Distance between points (DIST)</b> command.
<b>Edge units</b>	<b>Length units</b> – specifies that the value in the <b>Maximum length</b> field is set in the drawing units (meters). <b>Percent</b> – specifies that the value in the <b>Maximum length</b> field is set as percentage.
<b>Project points to UCS XY plane</b>	To define what triangles should be removed, lengths of edge projections are compared with the <b>Maximum length</b> . If specify <b>No</b> , projections to the plane of the current view will be used. If specify <b>Yes</b> , lengths of projections to UCS XY plane will be compared.

#### Command prompts:

Apply changes  
[Yes/No/Save/SaveDefault]  
<Yes>:

Yes – mesh bounding will be performed with the current settings.

No – if settings have been changed, they are not saved. Bounding will be performed with the settings that were displayed immediately after running the command.

**Edge that prevents from the correct construction of contours**

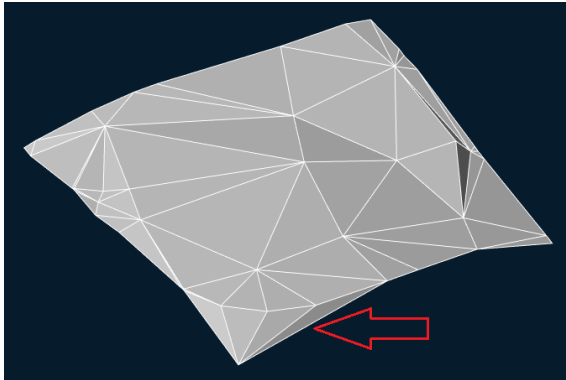

**Result of the mesh bounding**

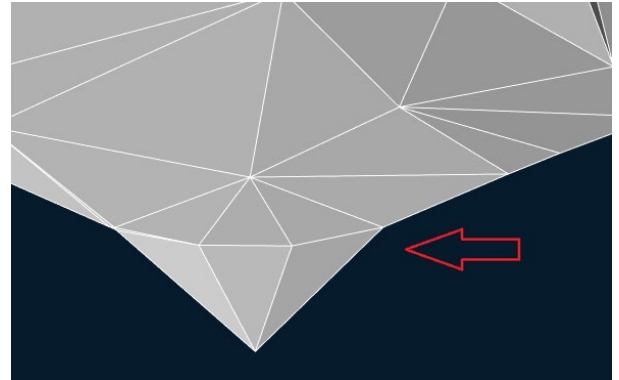

## Cutting Mesh

 Ribbon: **Topoplan – Modify TIN >**  **Cut Mesh**

 Menu: **Ground – Editing TIN >**  **Cut Mesh**

 Toolbar: **Editing TIN >**  **Cut Mesh**

 Command line: **NG\_MESH\_CUT**

The command's purpose is to split a mesh into divisions.

The command options are set on the **Properties** bar.

### Options:

<b>Save result as</b>	Influences on objects that will be created in the process of performing the command: a <b>Submesh</b> or <b>Polyfacemesh</b> can be created.
<b>Delete source mesh</b>	<b>Yes</b> – as a result of the command, several meshes will be created, and a source mesh will be deleted. <b>No</b> – as a result of the command, several meshes will be created, while the source mesh will also remain in a drawing.
<b>Specify closed contour</b>	<b>onScreen</b> – after changes are applied, indicate the nodes of cutting contour with the cursor; <b>Selection</b> – for cutting, select a previously prepared closed polyline in a drawing; <b>Profile</b> – indicate by the cursor the nodes in a drawing with possibility to extend the cutting profile to the mesh edges ( <b>Extendall</b> option) or to close ( <b>Close</b> option; if this option is selected, the result will be similar to selecting the <b>onScreen</b> option).

### Command prompts:

Apply changes <Yes> or  
[Yes/No]:

Yes – cutting will be performed with the current settings.

No – if settings have been changed, they are not

saved. Cutting will be performed with the settings that were displayed immediately after running the command.

## Classification Mesh

 Ribbon: **Topoplan – Modify TIN** >  **Classification Mesh**

 Menu: **Ground – Editing TIN** >  **Classification Mesh**

 Toolbar: **Editing TIN** >  **Classification Mesh**

 Command line: **NG\_MESH\_CLS**

The command is used to divide the mesh into classes: for example, if you want to separate the road surface from the lawn. For classification, in the drawing it is necessary to create polylines (necessarily closed), along which the mesh will be cut. After the mesh is classified, the resulting areas can be decomposed into layers to control the display (you can adjust the visibility, color, transparency, etc.)

The command options are set on the **Properties** toolbar.

### Options:

<b>Project profile on</b>	Determines how the polyline cutting the mesh will be projected on it: <b>WCS</b> – on XY plane of the world coordinate system. <b>UCS</b> – on XY plane of the user coordinate system (if available in the drawing). <b>Viewport</b> – on the viewport plane.
<b>Save result as</b>	The option influences on objects to be created in the process of performing the command: a <b>Submesh</b> or <b>Polyfacemesh</b> can be created.

### Command prompts:

Apply changes <Yes> or  
 [Yes/No]:

Yes – a triangle with the specified edge length will be deleted with the current settings.

No – if settings have been changed, they are not saved. A triangle with the specified edge length will be deleted with the settings that were displayed immediately after running the command.

**Mesh before classification**

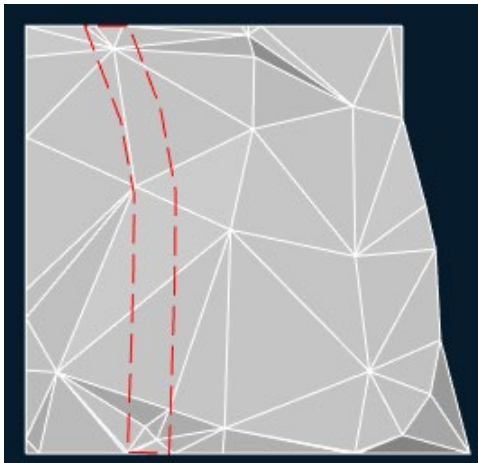

**Mesh after classification**

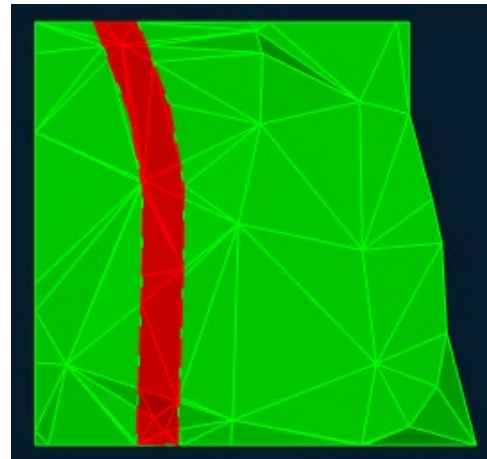

## Adding a group of Points

 Ribbon: **Topoplan – Modify TIN** >  **Adding a Group of Points**

 Menu: **Topoplan – Modify TIN** >  **Adding a Group of Points**

 Toolbar: **Modify TIN** >  **Adding a Group of Points**

 Command line: **NG\_MESH\_VERTEX\_ADD\_BY\_POINTS**

The command adds a group of points (geopoints, blocks) to the surface using the interpolation principle.

### To add a group of points:

1. Select one surface.

In response to a prompt on the command line -

Select point type or [Points/COGOPoints/Blocks]:

select the type of points.

3. In the **Properties** bar, configure the command parameters

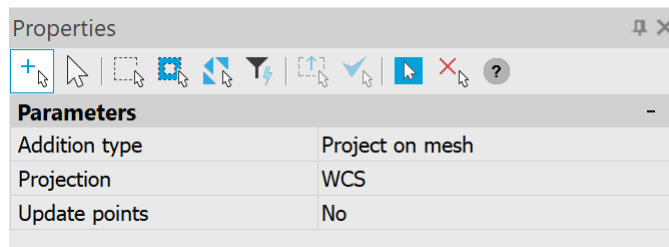







<b>Addition type</b>	<b>Project on mesh</b> – Project points of the mesh surface. <b>By point</b> – take current coordinates without projection.
----------------------	--

<b>Elevation source</b>	<p>The parameter is available when selecting the <b>By point</b> addition type</p> <p>Selection of the elevation source.</p> <p>For <b>points</b>:</p> <ul style="list-style-type: none"> <li>- Position</li> </ul> <p>For <b>COGOPoints</b>:</p> <ul style="list-style-type: none"> <li>- Position</li> <li>- Custom property</li> </ul> <p>For <b>blocks</b>:</p> <ul style="list-style-type: none"> <li>- Position</li> <li>- Attribute</li> </ul>
<b>Projection</b>	<p>The direction in which points will be projected onto the surface (WCS, UCS or Viewport).</p>
<b>Update points</b>	<p>The data of the point to be updated.</p> <p><b>No</b> – we change the surface, but do not change the starting points.</p> <p><b>Position</b> – we change the surface, as well as the position of the points to a new one, projected onto the surface.</p>

## Tools to Work with Relief Elements

### Constructing Contours

-  Ribbon: **Topoplan – Relief** >  **Constructing Contours**
-  Menu: **Ground – Elevation** >  **Constructing Contours**
-  Toolbar: **Elevation** >  **Constructing Contours**
-  Command line: **NG\_CREATE\_CONTOUR\_LINE**

Constructing contours. Contour lines are constructed on the base of Submesh or Polyfacemesh objects

Contours are divided into several types:

- **Intermediate contour lines;**
- **Index contour lines;**
- **Supplementary contour lines** (semi-contours). Are built on half of section of intermediate contour lines;
- **Auxiliary contour lines.** Are built with an arbitrary section, the value of which is set by the **Interval** parameter.

The command options are set on the **Properties** toolbar.

#### Common parameters for all contour lines:

<b>Delete existing contours</b>	<p>If contours are present in a drawing and they should be constructed anew – specify <b>Yes</b>.</p> <p>When you specify <b>No</b>, old contours are preserved.</p>
---------------------------------	--

<b>Create contours layer</b>	If you specify <b>Yes</b> , new contours will be created in the new <b>Contour lines</b> layer. In case of <b>No</b> , contours will be created in <b>0</b> layer.
<b>Contours smoothing</b>	<b>No</b> – contours consisting of straight segments will be built. <b>Yes</b> – constructing smoothed contour lines with a controlled degree of smoothness. It is recommended to use this way of smoothing ( <b>Bezier Interpolation</b> ).
<b>Smoothness level</b>	The higher the value, the smoother the contour lines will be. The parameter is displayed when the <b>Yes</b> value is set for the <b>Contours smoothing</b> parameter.
<b>Avoid contours crossing</b>	It is recommended to specify <b>Yes</b> , so that in case of complex relief not to build crossing contours. But this slows down the construction of contours, and in case of a smooth relief, it's better not to enable this parameter. The parameter is displayed when the <b>Yes</b> value is set for the <b>Contours smoothing</b> parameter.

*Specific options for each type of contour lines:*

<b>Section height</b>	Parameter for <b>Intermediate contour lines</b> type of contours. It is set in meters depending on the scale of the created plan.
<b>Contour interval</b>	Parameter for <b>Index contour lines</b> and <b>Auxiliary contour lines</b> type of contours. Section height. It is set in meters depending on the scale of the created plan.
<b>Drawing</b>	Parameters for <b>Supplementary contour lines</b> and <b>Auxiliary contour lines</b> type of contours. If you specify <b>No</b> – this type of contour lines will not be built. <b>All</b> – will be built for the entire mesh. <b>Specify area</b> – after applying the parameters, by the cursor specify the area inside of which these contours will be built.

*Command prompt:*

Apply changes  
[Yes/No/Save/saveDefault]  
<Yes>:

Yes – contours will be built with the current settings.

No – if settings have been changed, they are not saved. Contours will be built with the settings that were displayed immediately after running the command.

## Creating Bergstriches

-  Ribbon: **Topoplan – Relief** >  **Bergstriches**
-  Menu: **Ground – Elevation** >  **Bergstriches**
-  Toolbar: **Elevation** >  **Bergstriches**
-  Command line: **NG\_CREATE\_BERGSTRICH**



The command will create a bergstrich (in the form of block) at the specified location of the contour.

Contours must first be built and the scale of the topographic map selected.

**To create a bergstrich:**

1. Run the command.
2. In response to the prompt in the command line



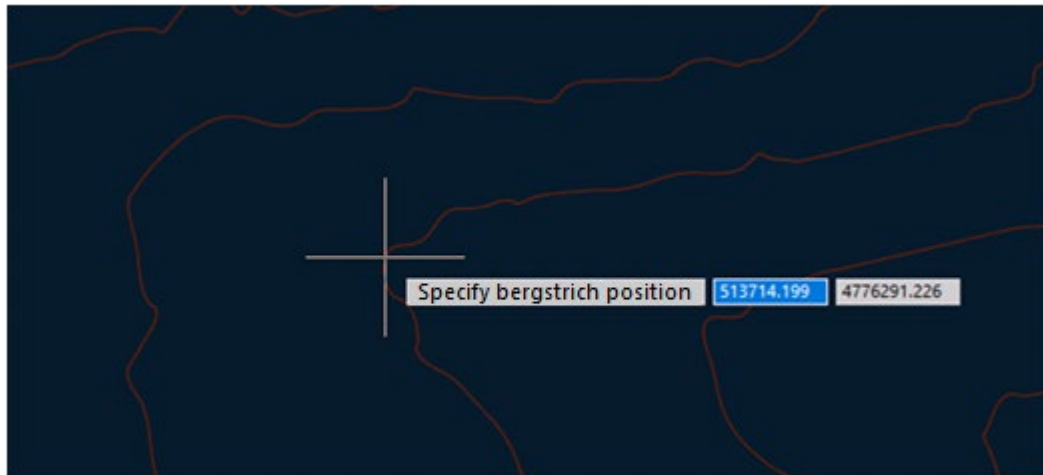

Specify bergstrich position:

click the left mouse button in the required place on the contour line.



3. In the specified place bergstrich will be created in form of block named CONTOUR\_BERG.
4. Several bergstriches can be created in succession. Pressing **ESC** button ends the command.

## Creating Contour Lines Labels

-  Ribbon: **Topoplan – Relief** >  **Contour Lines Labels**
-  Menu: **Ground – Elevation** >  **Contour Lines Labels**
-  Toolbar: **Elevation** >  **Contour Lines Labels**
-  Command line: **NG\_CREATE\_CONTOUR\_LABEL**

The command creates a label at the specified location of the contour.

Contours must first be built and the scale of the topographic map selected.

**To create labels for contour lines:**

1. Run the command.
2. If 3D visual style was set in a drawing, then a warning message appear at the command launch with the proposal to switch to 2D render mode. Agree for the right display of label elements.
3. In response to the prompt

Specify position of contour elevation label:

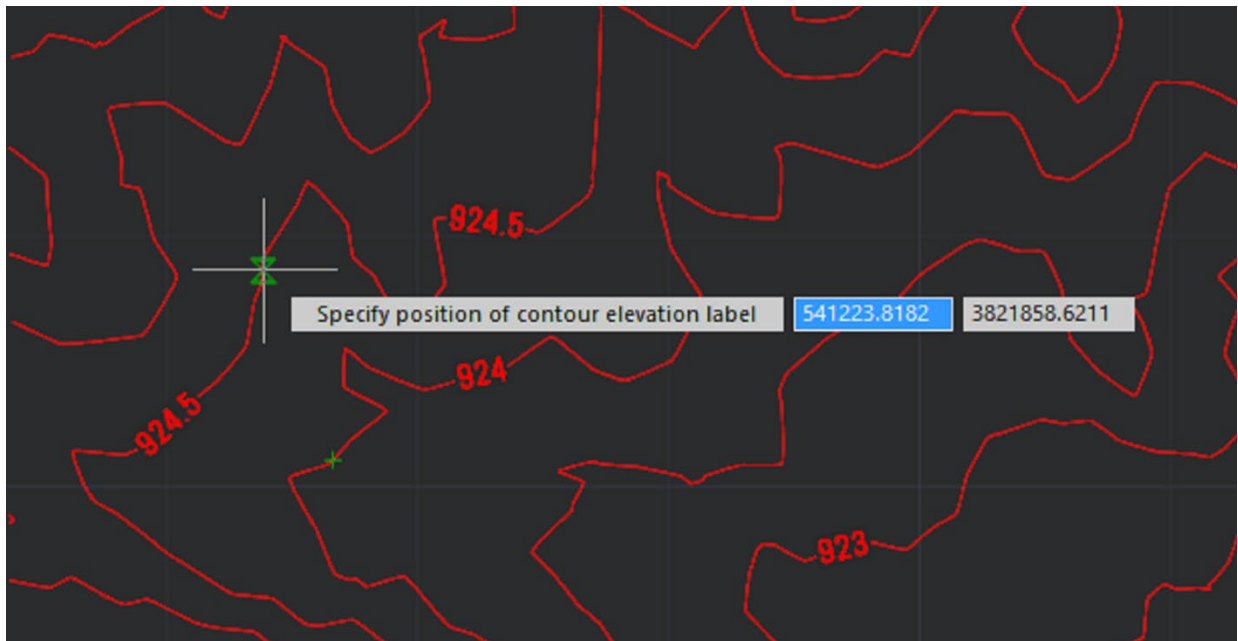

click on the contour line with enabled snap to create the **Mtext** object on the **Contour lines** layer with the enabled **Hide background** parameters to hide a contour area in the text insertion point.



It is not necessary to use an object snap: a label will be created on the contour line nearest to the cursor.

- Several labels can be created in succession. Pressing **ESC** button ends the command.

## 2D Slope

 Ribbon: **Topoplan – Relief** >  **2D Slope**

 Menu: **Topoplan – Relief** >  **2D Slope**

 Toolbar: **Relief** >  **2D Slope**

 Command line: **NG\_CREATE\_SLOPE**

The command makes it possible to build various types of signs for slopes, cliffs, retaining walls:

- Unfortified slope;
- Fortified slope;

- Steep coast with a beach;
- Steep coast without beach;
- Stone retaining walls;
- Wooden retaining walls;
- Ground cliff.

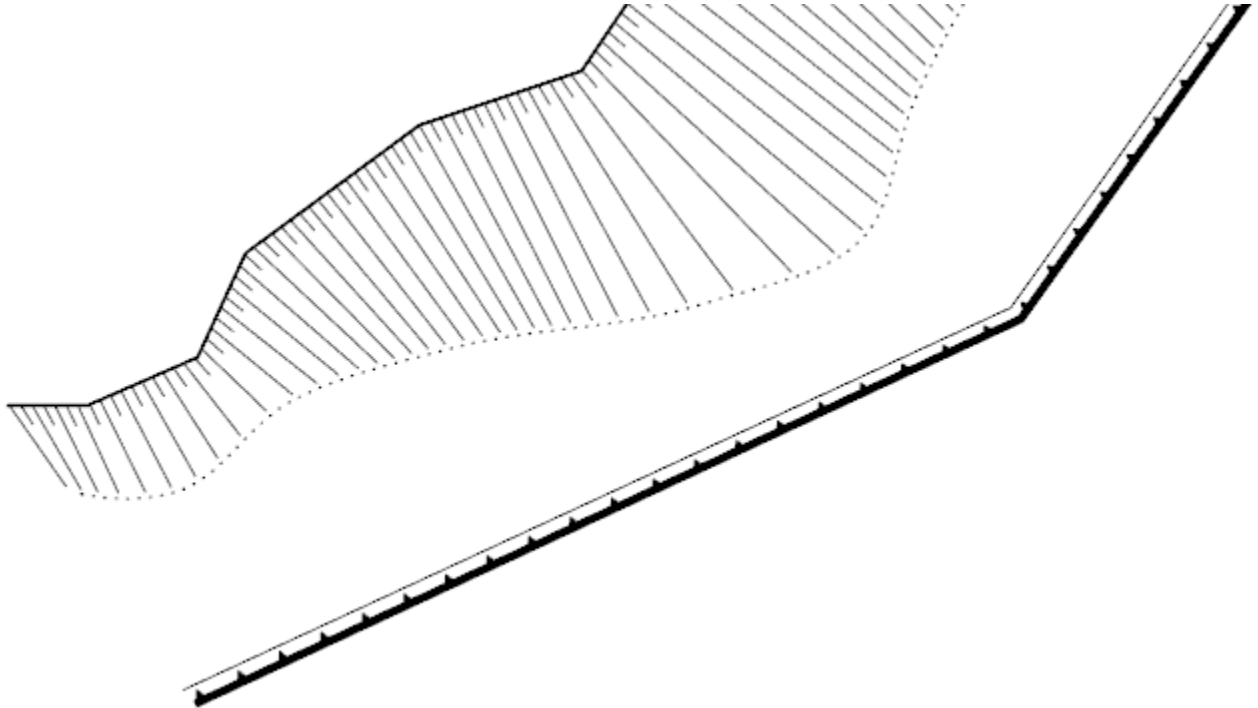

Before starting execution, the command checks the set topographic scale and offers to switch to the **2D Wireframe** visual style.

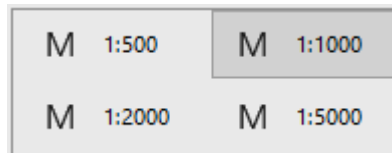

After running the command, set the slope type and characteristics in the **Properties** bar. The options vary depending on the type of slope and the way the edge is specified.

**Options:**

<p><b>Slope sign</b></p>	<p>Selecting the slope type:</p> <ul style="list-style-type: none"> <li>• Unfortified slope;</li> <li>• Fortified slope;</li> <li>• Steep coast with a beach;</li> <li>• Steep coast without beach;</li> <li>• Stone retaining walls;</li> <li>• Wooden retaining walls;</li> <li>• Ground cliff.</li> </ul>
--------------------------	--

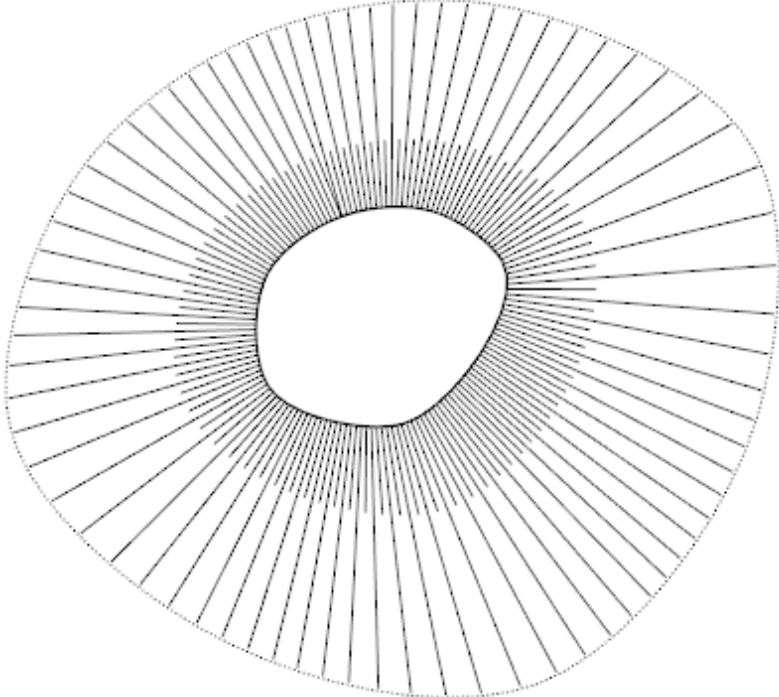
<p><b>Specify slope edges</b></p>	<p>Selecting the method for specifying the location of the slope in the drawing:</p> <ul style="list-style-type: none"> <li>• <b>onScreen</b> – slope boundaries should be drawn manually on the screen;</li> <li>• <b>Selection</b> – line objects that will define the lower and upper edge of the slope should be selected in the drawing field.</li> </ul> <p>The top and bottom slope edges can be closed lines.</p> 
<p><b>Smooth top of slope</b></p>	<p>Specify whether the top of the slope should be drawn from point to point as a polyline or a smooth line. The parameter is available for certain slopes, when the method for specifying the slope edge is <b>onScreen</b>.</p>
<p><b>Smooth bottom of slope</b></p>	<p>Specify whether the bottom of the slope should be drawn from point to point as a polyline or a smooth line. The parameter is available for certain slopes, when the method of specifying the slope edge is <b>onScreen</b>.</p>
<p><b>Draw bottom line</b></p>	<p>Specify whether the bottom slope line is required. The parameter is available for certain slopes, when the method of specifying the slope edge is <b>Selection</b>.</p>
<p><b>Layer of slope</b></p>	<p>The layer on which the slope should be placed.</p>

**Command prompts:**

Apply changes? <Yes>  
or [Yes/No]:

Yes – slope, cliff or retaining wall will be created with the current settings.

No – if the settings have been changed, they will not be saved. The slope will be created with the settings displayed immediately after running the command.

Specify points of slope top or [Peak]:

Specify the first point of the top edge of the slope, or select the Peak option to build the slope from a single top point (hill).

Specify slope peak point:

Specify a slope peak point to build a slope from one top point (hill).

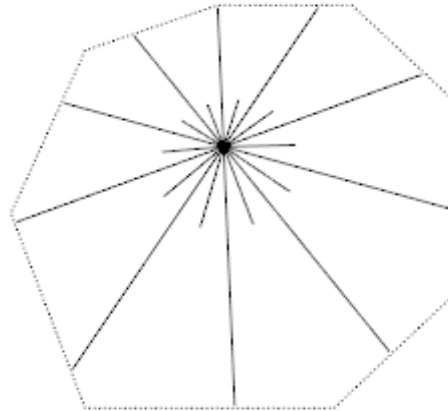

Specify points of slope top or [Undo/ClosePeak]:

Specify the second and subsequent peaks of the slope top.

Undo – undo the entry of the last specified peak.

ClosePeak – close the line of the slope top.

Specify points of bottom slope or [Undo/Close]:

Specify vertices of the slope bottom.

Undo – undo the entry of the last specified vertex.

Close – close the line of the slope bottom.

Select top slope polyline or [?]:

Specify a polyline on the screen to build the top edge of the slope based on it.

Select bottom slope polyline or [?]:

Specify a polyline on the screen to build the bottom edge of the slope based on it.

### **To create a slope, cliff, retaining wall:**

Set the desired topographic scale and switch to the **2D Wireframe** visual style.

Run the command.

Set the slope type and characteristics on the **Properties** bar. The options vary depending on the type of slope and how the edge is specified.

Specify the location of the slope on the drawing. Slope boundaries can be drawn manually, or created from existing drawing lines, depending on the value of the **Specify slope edges** option. The top and bottom slope edges can be closed lines. If you select the **Peak** option, you can create a slope from one top point (hill).

In the drawing, the slope is selected as a single set of objects, parts of which can be moved.

## **3D-Slope**



Ribbon: **Topoplan – Relief** >  **3D-Slope**



Menu: **Topoplan – Relief** >  **3D Slope**



Toolbar: **Relief** >  **3D-Slope**



Command line: **NG\_3D\_SLOPE**

The **3D-Slope** command creates a 3D slope from a surface or from existing objects.

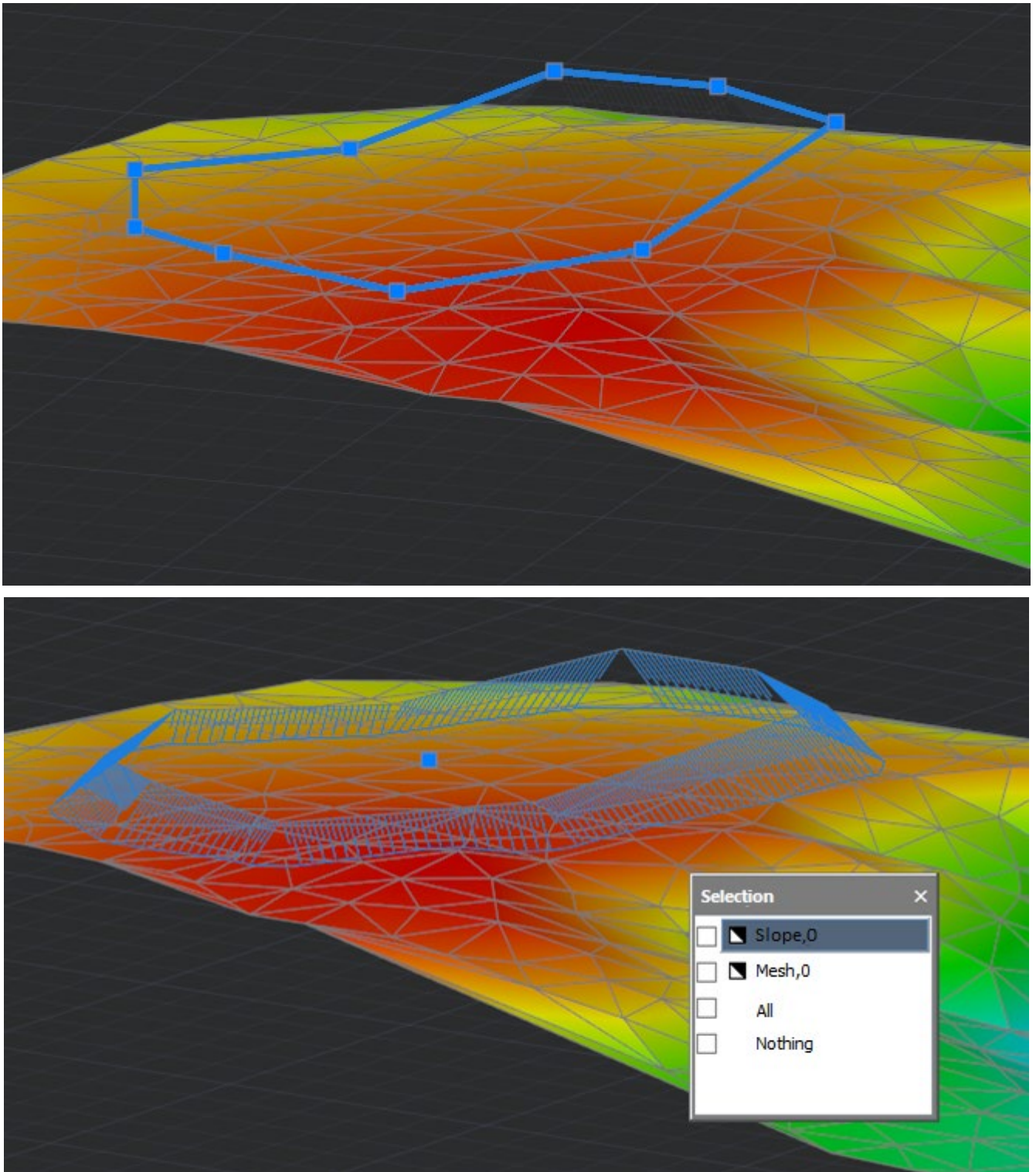

After running the command, set the slope type and characteristics in the **Properties** bar. The options vary depending on the type of slope and the way the edge is specified.

**Options:**

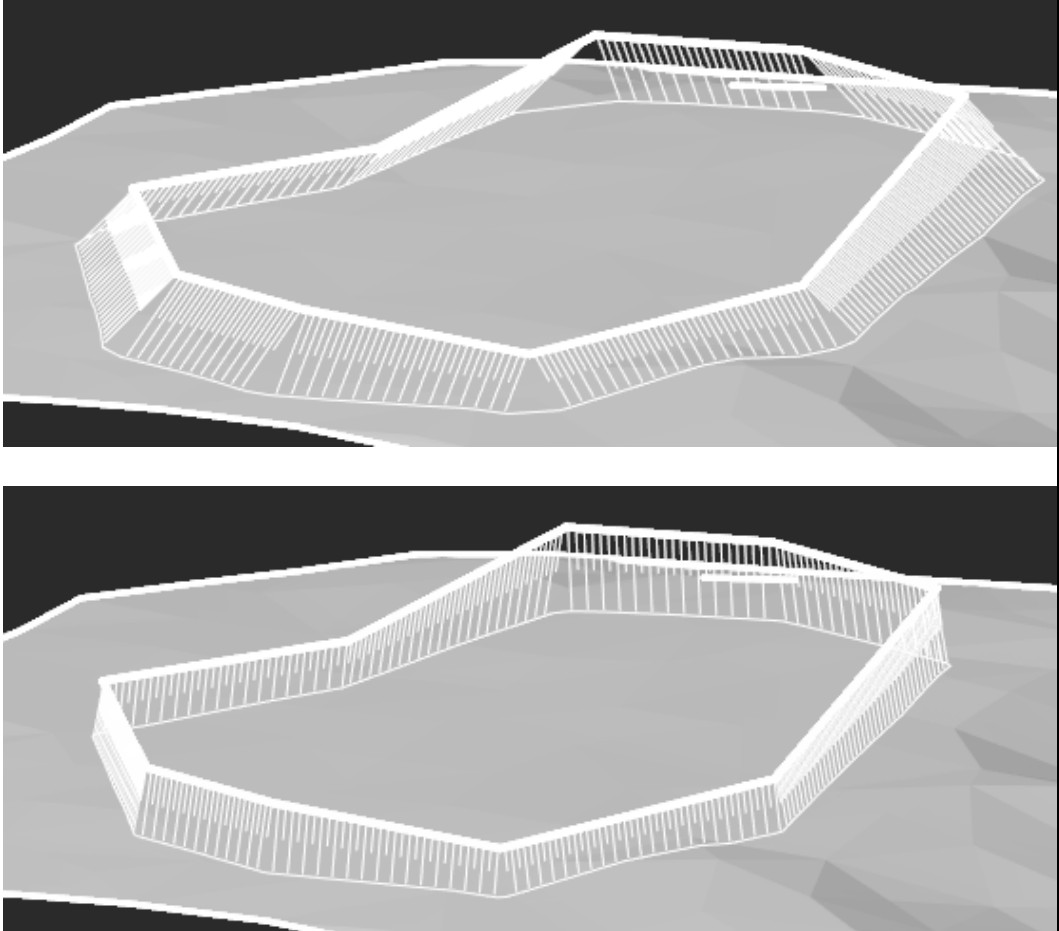
<p><b>Construction method</b></p>	<p>Selecting the method for specifying the slope location, its parameters and objects on the basis of which it should be built:</p> <ul style="list-style-type: none"> <li>• <b>Set Values</b> – the slope will be created on the basis of one linear object (polyline, circle, segment or arc) specified as the top edge, according to the specified fixed values of the parameters (<b>Slope Width, Slope Height, Slope Angle</b> and <b>Step</b>);</li> <li>• <b>From Object</b> – a pair of linear objects (polyline, circle, segment, arc) should be selected in the drawing field, they will define the lower and upper edges of the slope.</li> <li>• <b>From Surface</b> – the slope will be created from the specified 3D polyline to the triangulated surface (TIN).</li> </ul> <p>The top and bottom slope edges can be closed lines.</p>
<p><b>Width of slope</b></p>	<p>A constant slope width measured from the edge defined by the linear drawing entity.</p>
<p><b>Height of slope</b></p>	<p>The height of the slope, measured from the edge defined by the linear drawing entity.</p>
<p><b>Angle of slope</b></p>	<p>The slope angle of the slope edge relative to the vertical axis. Can be specified between 0 and 90 degrees. The slope angle determines the size and position of the bottom edge of the slope. If you are building a slope to the surface, then the bottom edge of the slope should also be within the boundaries of the TIN.</p> 

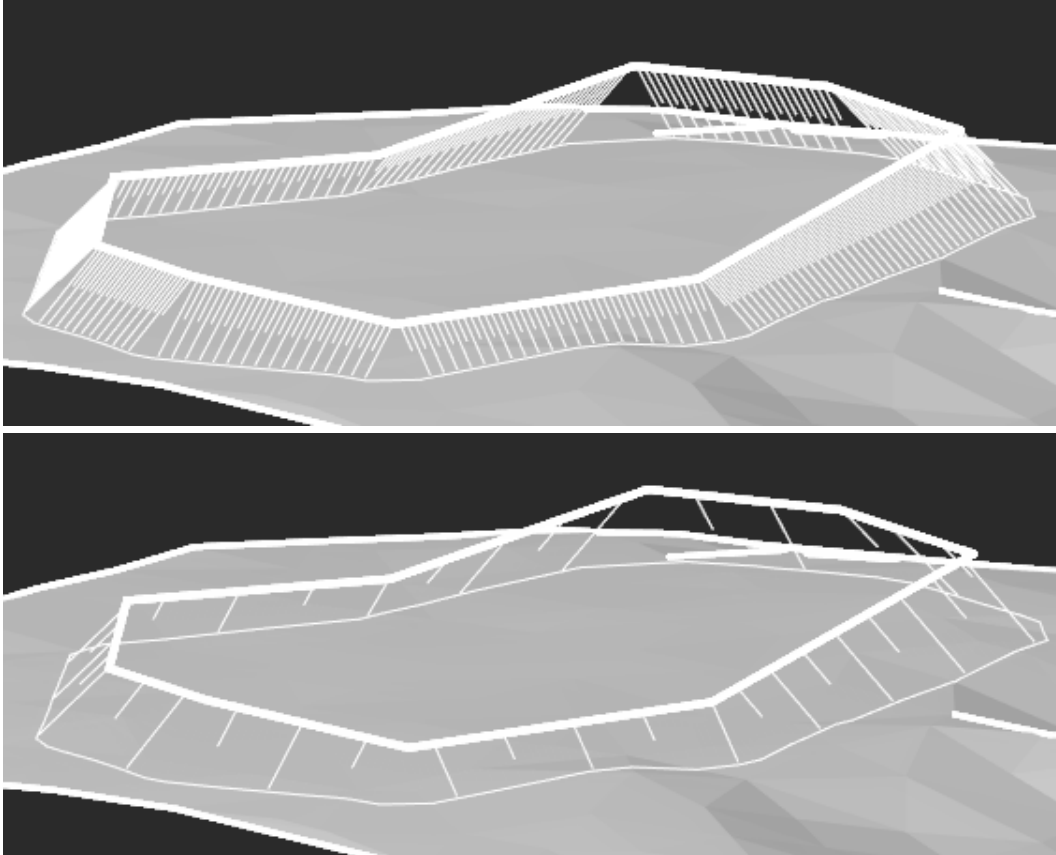
<p><b>Step of slope</b></p>	<p>Step of the slope line.</p> 
<p><b>Layer of slope</b></p>	<p>Layer on which the slope should be placed.</p>

**Command prompts:**

Apply changes  
<Yes> or  
[Yes/No/saveDefault]:

Select  
polyline/  
line/  
circle/ arc  
or [?]:

Select  
first  
polyline/  
line/  
circle/ arc  
or [?]:

Select  
second  
polyline/  
line/  
circle/ arc  
or [?]:

Yes – the slope will be created with the current settings.

No – if the settings have been changed, they will not be saved. The slope will be created with the settings displayed immediately after running the command.

saveDefault – save the default settings.

Select a linear object to define the edge of the slope: polyline, circle, line segment or arc. The polyline can be closed.

Select a linear object to specify the first slope edge: polyline, circle, line, or arc. The polyline can be closed.

Select a linear object of the same type as the first one to specify the second slope edge.



Specify height of second edge:

If both objects are at the same height relative to the XY plane, you will need to specify the height of the second slope edge.

Select 3D-polyline:

Specify a 3D polyline to define the top edge of the slope. The polyline should not extend beyond the boundaries of the TIN in the XY plane and lie above the triangulation surface. The 3D polyline can be closed.

Specify direction of slope construction:

Specify the direction of the slope edge bevel relative to the vertical line, i.e. the direction in which the **Slope angle** will be drawn.

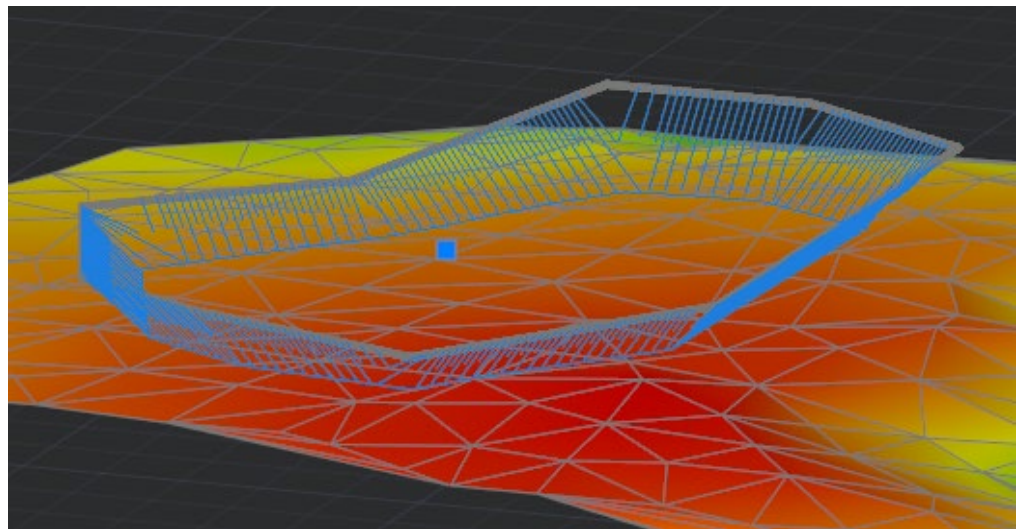

Specify points of slope top or  
[Undo/Close]:

Specify the vertices of the lower edge of the slope.  
Undo – cancel the input of the last specified vertex.  
Close – close the line of the lower edge of the slope.

Select polyline of slope bottom or  
[?]:

Specify a polyline on the screen to build the bottom edge of the slope based on it.

## Offset of a 3D-Polyline

 Ribbon: **Topoplan – Relief** >  **Offset of a 3D-Polyline**

 Menu: **Topoplan – Relief** >  **Offset of a 3D-Polyline**

 Toolbar: **Relief** >  **Offset of a 3D-Polyline**

 Command line: **3DPOLYOFFSET**

The command draws a 3D polyline similar to the selected one at a specified distance from the original one, with an offset in the XY plane of the current UCS.

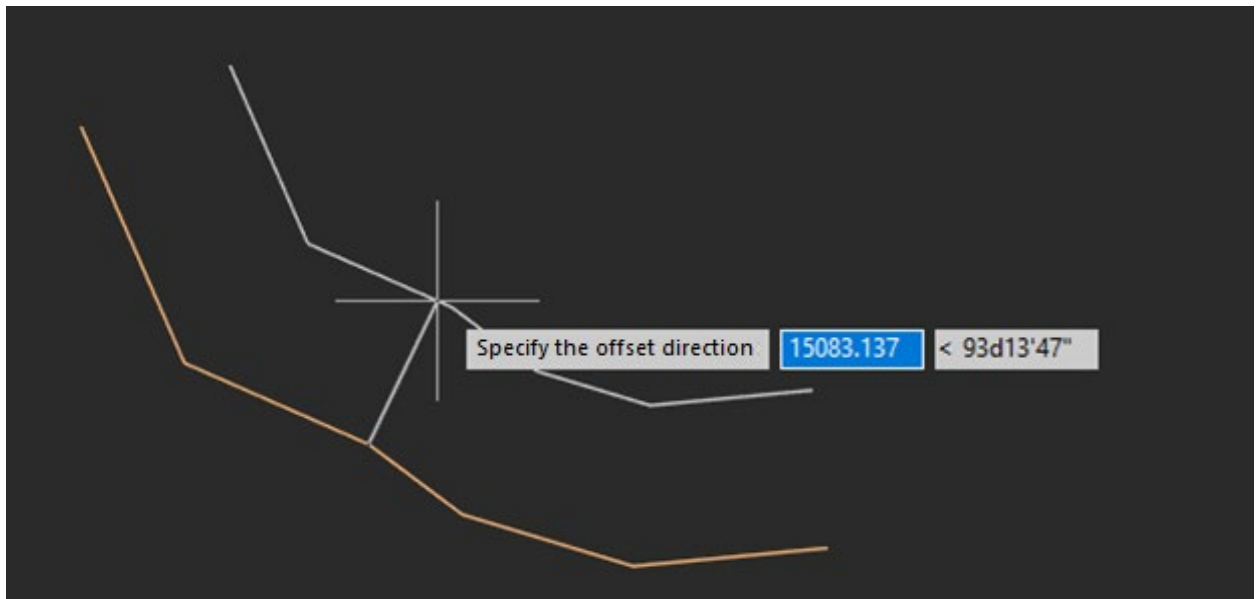

### Command prompts:

Select mode [Delete/Keep]:

Set the distance by entering a value from the keyboard or by pointing on the screen.

Select 3dPolyline or:

Select a 3D polyline for which you want to draw a similar one.

Specify the offset direction:

Specify the offset direction and approximate offset distance.

Offset distance:

Enter exact offset distance

## Deleting Contour Lines

 Ribbon: **Topoplan – Relief** >  **Delete Contour Lines**

 Menu: **Topoplan – Relief** >  **Delete Contour Lines**

 Toolbar: **Relief** >  **Delete Contour Lines**

 Command line: **NG\_DELETE\_CONTOUR\_LINE**

The command has no settings. When it is launched, all contours, berghashes and contour labels are deleted.

## Building a Profile Line

 Ribbon: **Topoplan – Relief** >  **Building a Profile Line**

 Menu: **Ground – Elevation** >  **Building a Profile Line**

 Toolbar: **Elevation** >  **Building a Profile Line**



Command line: **NG\_PROFILE\_LINE**

The **Building a Profile Line** command allows you to create **3d Polyline** type object that is located on the mesh and exactly repeat its relief in the specified place. To create an object, it is necessary to have a constructed triangulation mesh.

The profile line is specified by indicating several nodes, with the possibility of automatic closing its ends or extending them to the edges of the mesh. Profile lines can be used to place surface elevations along roads, generate reports, etc.

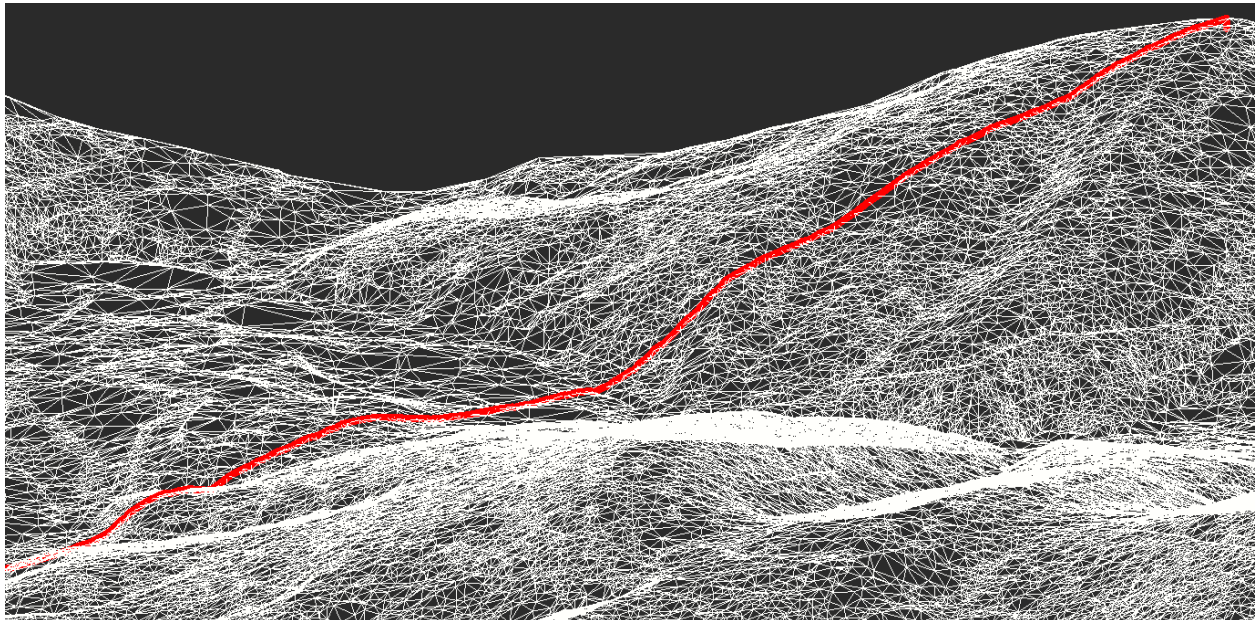

## *Search for Key Lines on the Surface*



Ribbon: **Topoplan – Relief** >  **Search for Key Lines**



Menu: **Topoplan – Relief** >  **Search for Key Lines**



Toolbar: **Relief** >  **Search for Key Lines**



Command line: **NG\_KEY\_LINES**

The command searches for key lines such as thalwegs, edges, etc. on the surface.

### *Parameters:*

There are two parameters to set first: **Resolution** and **Isolation Distance**. The rest can be left at their default values for the first time, since they do not depend on drawing units.

#### *Resolution*

The main parameter. It specifies the detail, such as how large the radius around a point will be to determine if it has a bend. It also defines the step between the points of the resulting polylines.

The parameter is measured in drawing units. Usually the optimal value is 4-5 meters.

If the value of the **Resolution** parameter is too low (high resolution), the slightest bends in the relief will be detected, but smooth bends, which are more important in terms of the key lines of the relief, may not be detected. So, if you are creating a lot of scattered small lines, the value of the **Resolution** parameter is most likely too low.

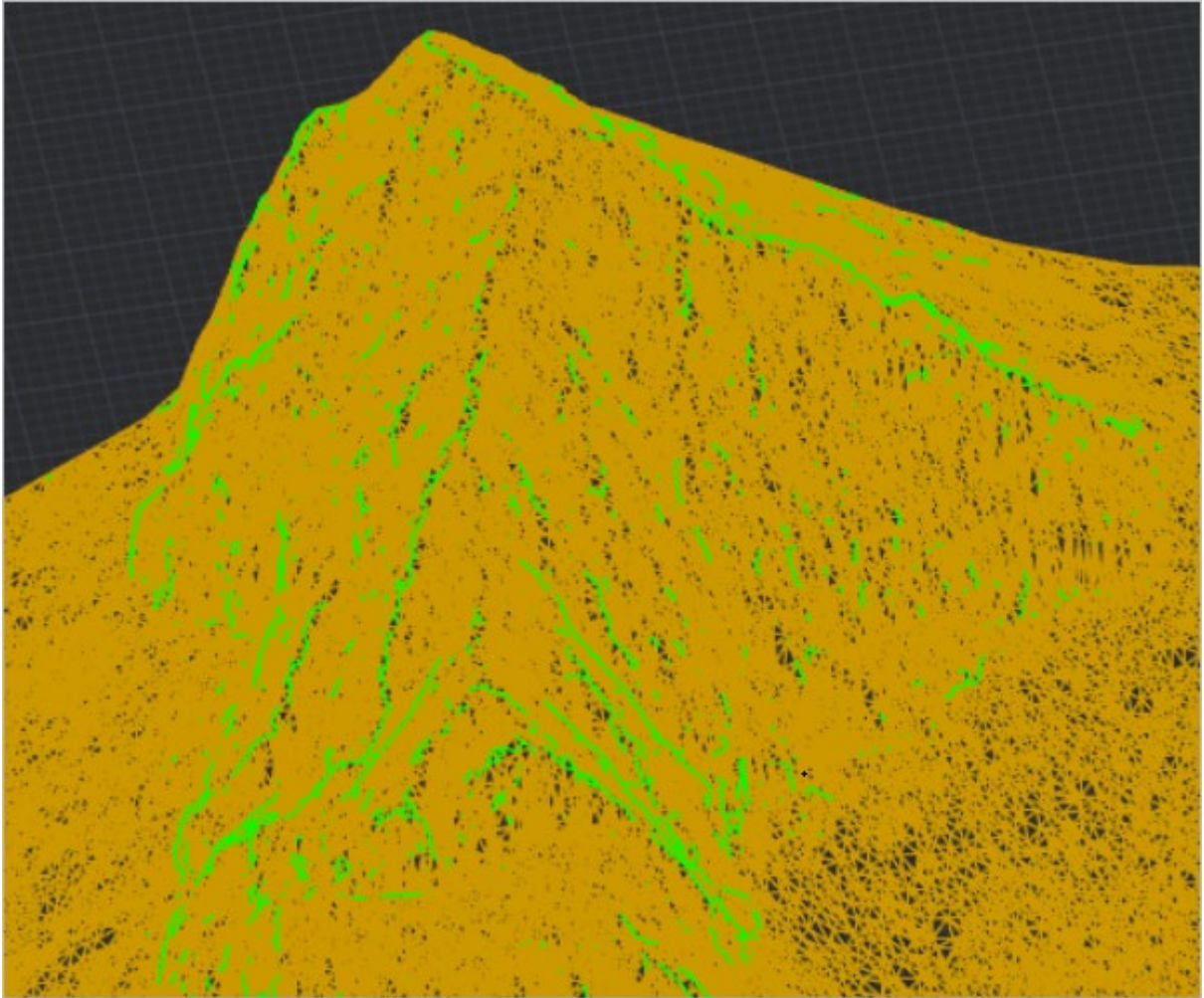

If the parameter value is too high, the opposite picture is obtained: there are few lines and they are very inaccurate. If at the same time the **Isolation Distance** parameter, which is responsible for the integrity of the lines, is set twice as high as the **Resolution** parameter value, then the lines will be even smaller and they will fall apart, and if set much more, the lines will stick together where they are not needed. The example below shows just such a situation: too high a value for the **Resolution** parameter with a large value for the **Isolation Distance** parameter.

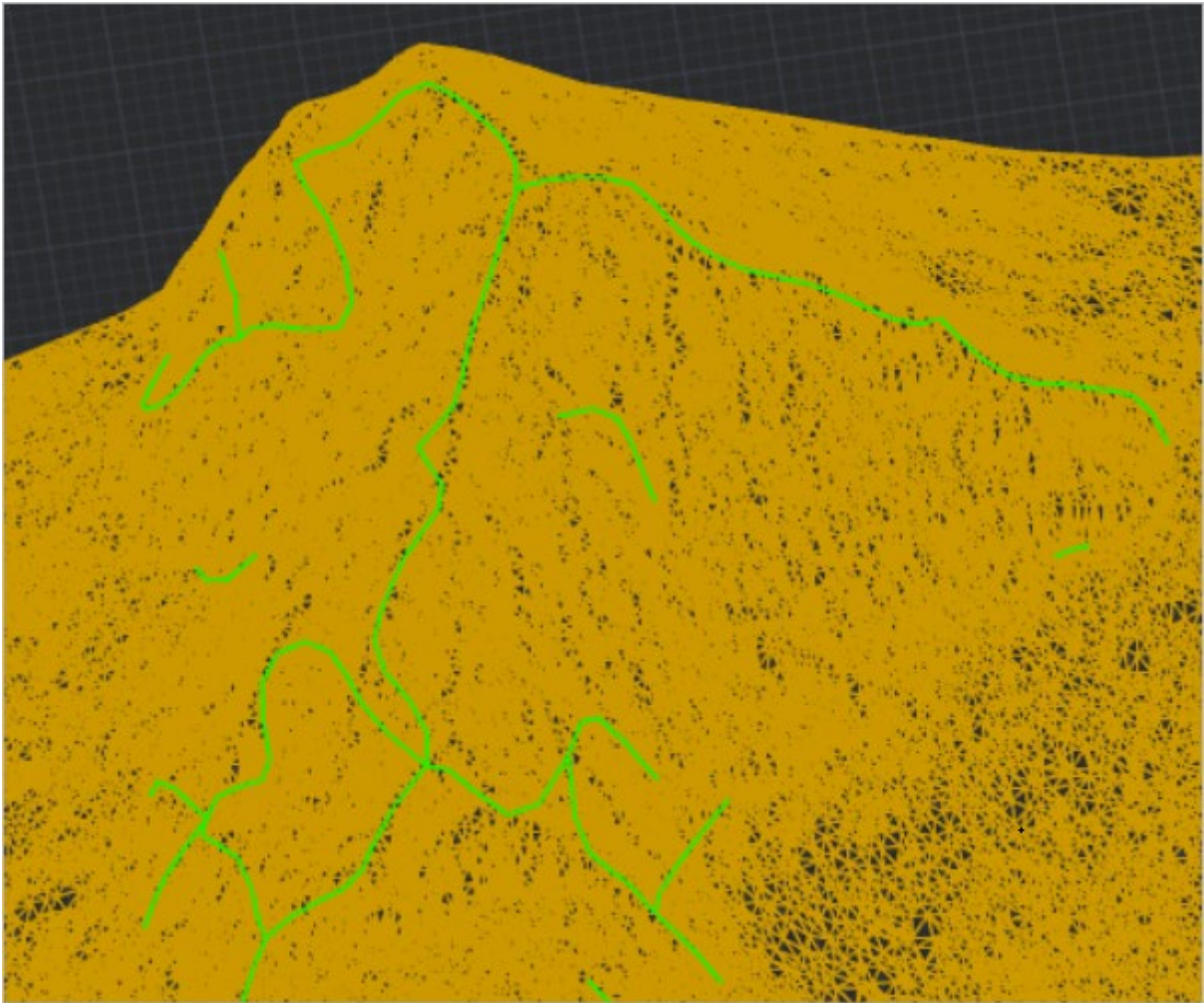

### *Isolation distance*

The value of this parameter is also specified in drawing units. The **Isolation Distance** parameter is closely related to the **Resolution** parameter. It affects how the lines are separated from one another. If the values are too high, the lines will stick together, if the values are too low, they will fall apart. The value of the **Isolation Distance** parameter should be greater than the value of the **Resolution** parameter, otherwise nothing will be detected. The optimal value is three to five times greater than the **Resolution**.

### *Key Point Percent*

The parameter determines how sharp corners are considered bends. It is necessary to increase the parameter value if you need to recognize more bends, and decrease it to reduce their number and take into account only the sharpest corners. This parameter is also related to the **Resolution** parameter, since a bend is considered to be within the sphere of the radius determined by the resolution. The parameter values vary from 0 to 1. As a rule, the optimal value is 0.075.

### *Smoothing Pass band and Smoothing Iterations*

**Smoothing Pass band** and **Smoothing Iterations** are parameters for smoothing lines. It makes sense to change them only if the lines seem to zigzag and they should be smoothed out even more. In this case, you can try to increase the number of iterations. In most cases, you do not need to change the parameter values. Values of the **Smoothing Pass band** parameter are set in the range from 0 to 2, smaller values correspond to more smoothing.

The example below shows lines obtained from only one iteration. They are practically without smoothing, you can see that they go a little zigzag.



### Projection

By default, the resulting lines found do not lie on the mesh surface. To project them vertically onto the relief, you can set the **Projection** parameter to **Vertical**.

## Projecting a Line onto a Mesh



Ribbon: **Topoplan – Relief** >  **Projecting a Line onto a Mesh**



Menu: **Ground – Elevation** >  **Projecting a Line onto a Mesh**



Toolbar: **Elevation** >  **Projecting a Line onto a Mesh**



Command line: **NG\_TO\_PROFILE\_LINE**

The command is designed to project the existing plan elements onto a surface.

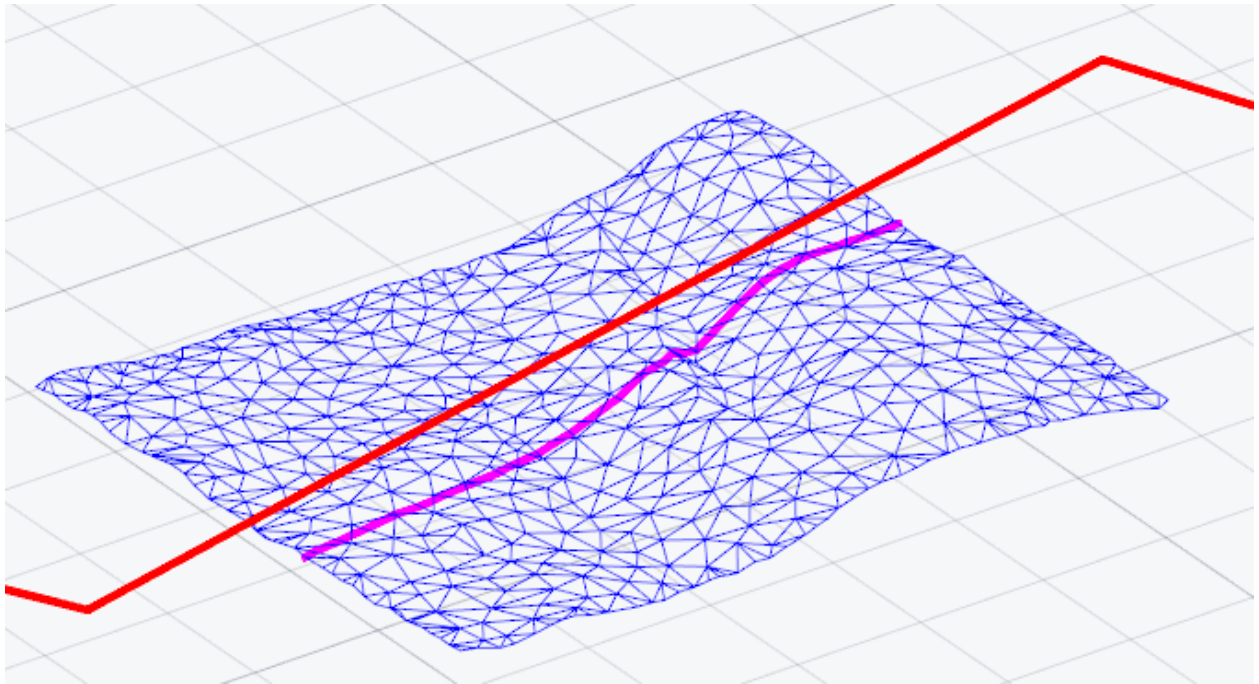

### Command prompts:

Project profile on or  
[WCS/UCS/Viewport]:

Defines how the polyline will be projected onto the mesh:

WCS – on the XY plane of the world coordinate system.

UCS – on the XY plane of the user coordinate system (if available in the drawing).

Viewport – on the viewport plane.

Select polyline to build  
profile line or [?]:

Select line, polylines or 3D polylines to project onto the mesh.

## Correction of Zero Elevation



Ribbon: **Topoplan – Relief** >  **Correction of Zero Elevation**



Menu: **Ground – Elevation** >  **Correction of Zero Elevation**



Toolbar: **Elevation** >  **Correction of Zero Elevation**



Command line: **NG\_ADJUST\_ZERO\_ELEVATIONS**

The command changes the elevations (Z coordinate) of a 3D polyline, aligning them in the range from one valid elevation to another using the linear interpolation method.

When running the command, specify 3d polyline in the drawing and press **ENTER**. The nodes the Z coordinates of which had 0 value, will be corrected.

**NOTE:** Zero values of Z coordinates of endpoints of 3d polylines will be corrected for non-zero values of Z coordinates of adjacent points.



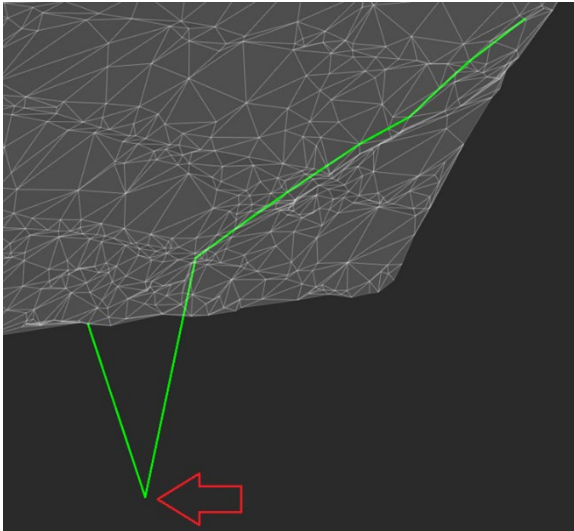

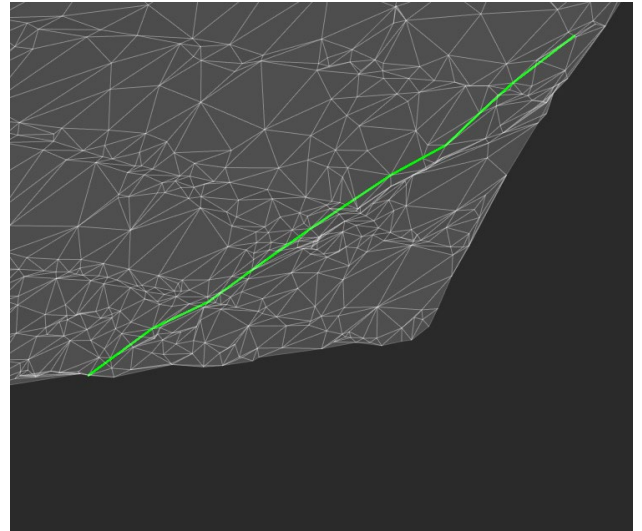

**Node of 3D polyline that needs correction**



**3D polyline after correcting elevation**



## Projecting Objects onto a Surface

-  Ribbon: **Topoplan – Utilities** >  **Project Objects onto a Surface**
-  Menu: **Topoplan – Utilities** >  **Project Objects onto a Surface**
-  Toolbar: **Topoplan Utilities** >  **Project Objects onto a Surface**
-  Command line: **NG\_MESH\_PROJECT\_OBJECTS**

The command projects objects - blocks, points, geopoints, texts, Mtexts - onto the surface. The elevation (Z coordinate) of the listed objects changes to the surface elevation. After running the command, specify the Network object in the drawing.

The command options are set in the **Properties** bar.

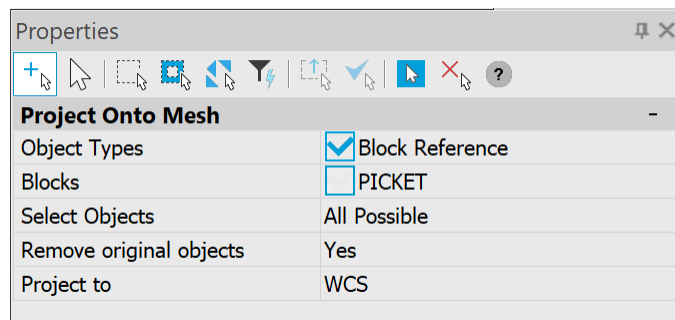

<b>Object types</b>	Types of objects that will be projected (Block Reference, Point, Geopoint, Text, Mtext).
<b>Select Objects</b>	Area for selecting objects (All Possible, On Screen).
<b>Remove original objects</b>	Specifying whether to delete the original objects or not.
<b>Project to</b>	Determines how the object will be projected onto the mesh.



## Managing Block Marker Attributes

 Ribbon: **Topoplan – Utilities** >  **Managing Block Marker Attributes**

 Menu: **Topoplan – Utilities** >  **Managing Block Marker Attributes**

 Toolbar: **Topoplan Utilities** >  **Managing Block Marker Attributes**

 Command line: **NG\_H\_TO\_ATTRIBUTE**

The command copies the Z coordinate value of a block to its attribute and vice versa, and also swaps the Z coordinate and attribute values.

The command options are set in the **Properties** bar.

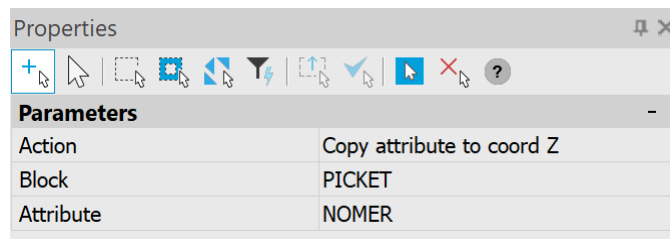

<b>Action</b>	<p><b>Copy attribute to coord Z</b> - fills the value of the Z mark with the value of the selected block attribute (only if the attribute has a numeric value).</p> <p><b>Copy coord Z to attribute</b> - fills the selected block attribute with the Z mark value.</p> <p><b>Swap attribute and coord Z</b> - is selected in the case when the attribute value and the Z mark value should be swapped.</p>
<b>Block</b>	Block selection.
<b>Attribute</b>	Attribute selection.

## Texturing and Calculation

### Flat Texture Overlay

 Ribbon: **Topoplan – Texturing and Calculation** >  **Flat Texture Overlay**

 Menu: **Ground – Textures** >  **Flat Texture Overlay**

 Toolbar: **Textures and calculations** >  **Flat Texture Overlay**

 Command line: **NG\_ORTHO\_TEXTURE**

Using this command, you can create a textured surface if the drawing contains a point cloud with the **can Color** attribute (its display should be enabled) and a surface created from this point cloud. The command allows you to create a photorealistic image of the earth model.

After running the command, specify the **Submesh** object in the drawing.

The command options are specified on the **Properties** toolbar.

**Options:**

<b>Texture size</b>	Set in pixels.
<b>Format</b>	Possible formats are BMP, JPG, PNG, TIFF.
<b>From the ground</b>	<b>Yes</b> – the color of cloud’s point will be projected onto the surface, as if looking from the ground. If <b>No</b> is selected, the color will be projected as if looking from above

**Command prompts:**

Apply changes? <Yes> or  
[Yes/No]:

Yes – the texture overlay will be performed with the current settings.

No – if the settings have been changed, they are not saved. The texture overlay will be performed with the settings that were displayed immediately after running the command.

**Mesh before the texture overlay**

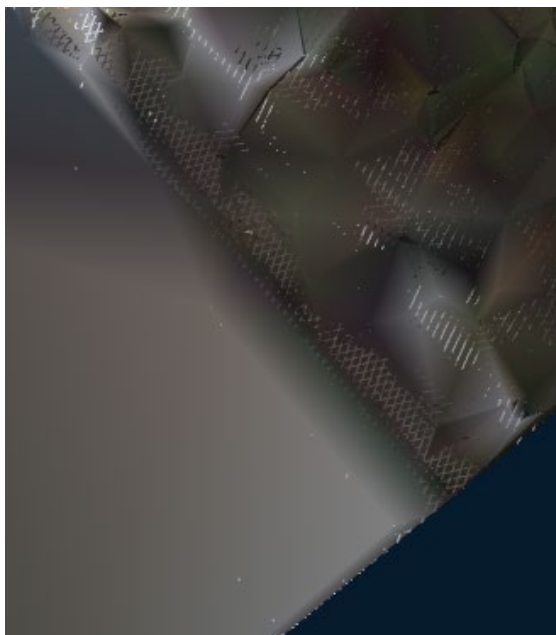



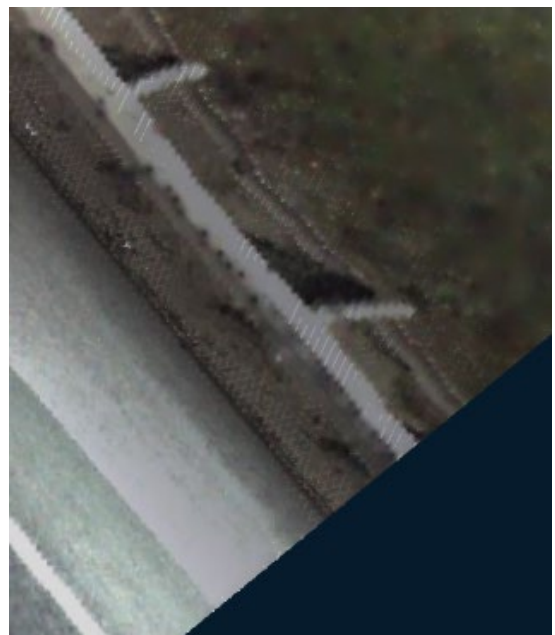

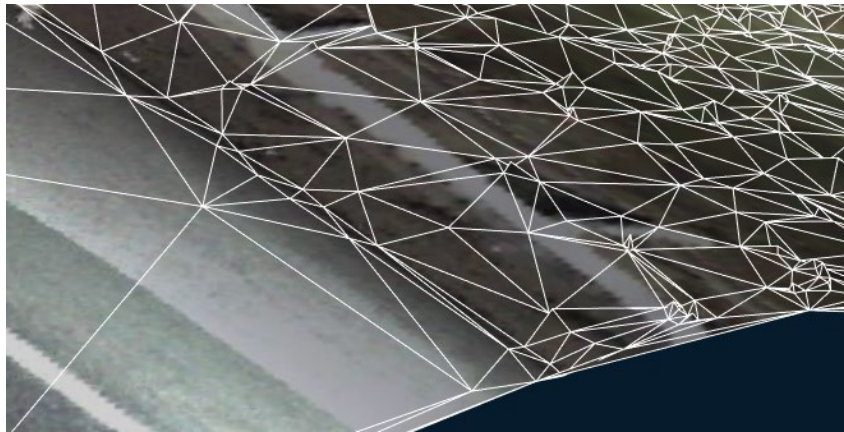

**Mesh after the texture overlay**



After removing the point cloud from the drawing, the surface preserves the texture:



## Raster Texture Mapping

-  Ribbon: **Topoplan – Texturing and Calculations** >  **Raster Texture Mapping**
-  Menu: **Ground – Textures** >  **Raster Texture Mapping**
-  Toolbar: **Textures and Calculations** >  **Raster Texture Mapping**
-  Command line: **NG\_ORTHO\_IMAGE**

With this command you can create a textured surface. The texture is created by mapping any raster loaded in the drawing on the mesh.

After running the command, in response to the corresponding prompts, select sequentially **Submesh** and **Raster image** object in the drawing.

**Mesh before texture mapping**

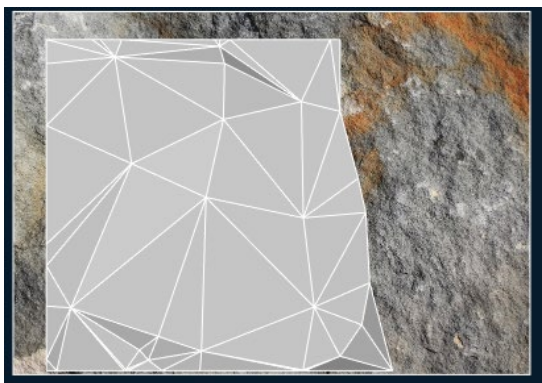



**Mesh after texture mapping**

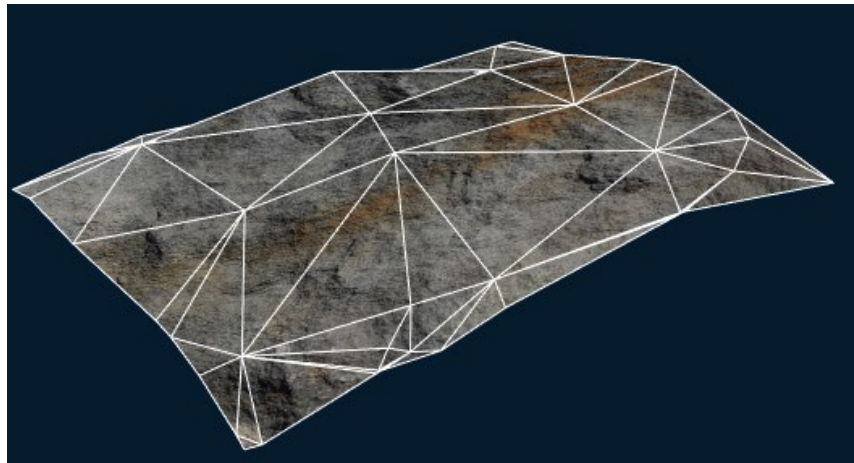

After removing the raster from the drawing, the surface preserves the texture:



## Mesh Coloring by Height

 Ribbon: **Topoplan – Texturing and Calculations** >  **Mesh Coloring by Height**

 Menu: **Ground – Textures** >  **Mesh Coloring by Height**

 Toolbar: **Textures and Calculations** >  **Mesh Coloring by Height**

 Command line: **NG\_PAINT\_ELEVATION**

With this command you can create a textured surface with gradient paint. Sets the initial (color of minimum) and final (color of maximum).

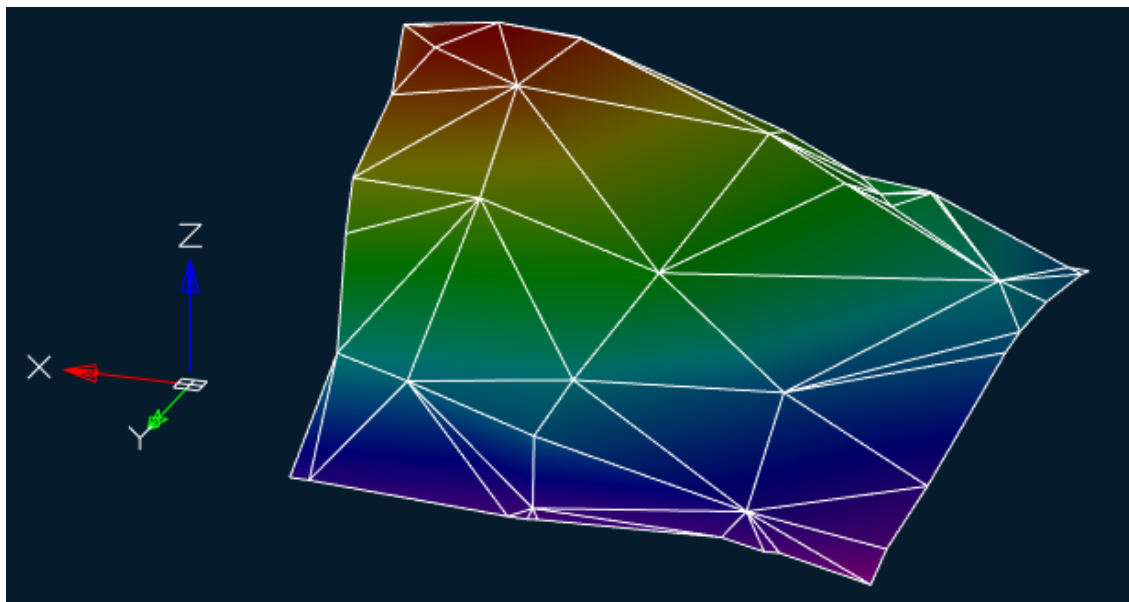

After running the command, specify the **Mesh** object in a drawing.

The command options are specified on the **Properties** toolbar.

Parameters	
Min Value	0.00
Max Value	104.80
Out of Range Color	White
Gradient	
Gradient type	Continuous
Smooth isocontours	No

**Options:**

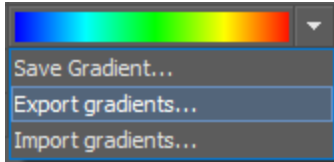
<b>Min Value</b>	The minimum height value from which the surface will be painted.
<b>Max Value</b>	The maximum height value above which surface painting will not be performed.
<b>Out of Range Color</b>	<p>The color of an uncolored surface if the minimum and maximum values are set to something other than the minimum and maximum elevation of the surface.</p> <ul style="list-style-type: none"> <li>• <b>Black.</b></li> <li>• <b>White.</b></li> <li>• <b>Border</b> – the color will correspond to the end color of the established gradient.</li> </ul>
<b>Gradient</b>	<p>Gradient image of the future surface. A single click on the gradient opens a drop-down menu:</p>  <ul style="list-style-type: none"> <li>• <b>Save Gradient</b> – saves the gradient in the current document</li> <li>• <b>Export gradients</b> – saves the gradient to an XML file.</li> <li>• <b>Import gradients</b> – imports the gradient from an XML file.</li> </ul> <p>A double click on the gradient image opens the gradient editor, discussed below.</p>
<b>Gradient type</b>	<p><b>Continuous</b> – the surface will be painted with smoothly transitioning colors.</p> <p><b>Discrete</b> – each color will be configured separately, the borders between colors are displayed with a clear line. When you select this option, you can specify the number of color intervals and adjust each color separately.</p>
<b>Smooth isocontours</b>	Possibility to smooth the gradient edges. The parameter is reserved for the next version

Double-clicking on the gradient image opens the gradient editor, where you can set your own colors and the location of the color transition points.

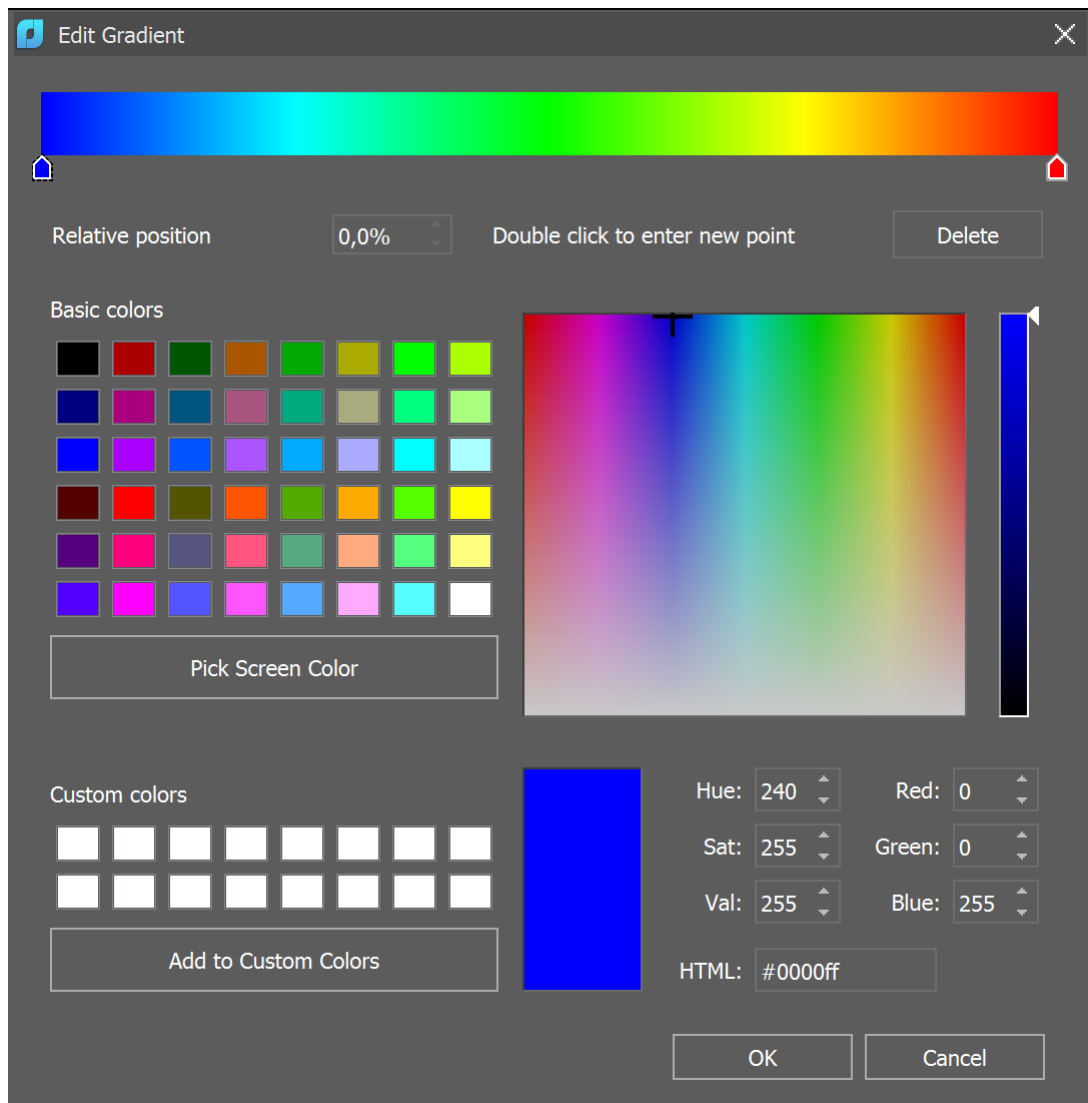

Initially, the gradient scale contains only two extreme points, for which you can set a new color by first clicking on any of them.

A new color transition point is set by a double click in the desired area of the gradient. A new point will appear at this location.

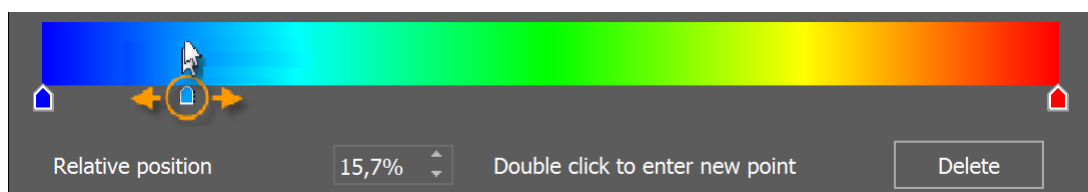

It is possible to:

- select a point by clicking on it (after creation, the point is selected automatically). In this case, the dialog displays its exact color and position;
- set a new point color using any color setting method in the dialog, including selecting a color from the screen. In this case, the coloring of the gradient scale will change in accordance with the new color of the point;
- specify a new location of the point on the gradient scale by moving it along the scale or by entering a relative position value. In this case, the coloring of the gradient scale will change in accordance with the new position of the point. The extreme points of the gradient scale cannot be moved;

- delete the point with the **Delete** button. The coloring of the gradient scale will change according to the remaining number and location of points. The extreme points of the gradient scale cannot be deleted.

**Command prompt:**







Apply changes <Yes> or [Yes/No]:

Yes – the mesh will be painted with the current settings.

No – if the settings have been changed, they are not saved. The mesh will be painted with the settings that were displayed immediately after running the command.

To display the completed coloring, set the visual style to **Realistic** or **X-Ray**, or a custom style in which texture display is enabled in the face parameters.

## Calculating Volumes between Models

-  Ribbon: **Topoplan – Texturing and Calculations** >  **Volume between Models**
-  Menu: **Ground – Calculations** >  **Volume between Models**
-  Toolbar: **Textures and Calculations** >  **Volume between Models**
-  Command line: **NG\_VOLUMES**

The command allows you to calculate the volume of surfaces: Total, Differenced and Balance. Such calculations are often performed to determine the amount of excavation works.

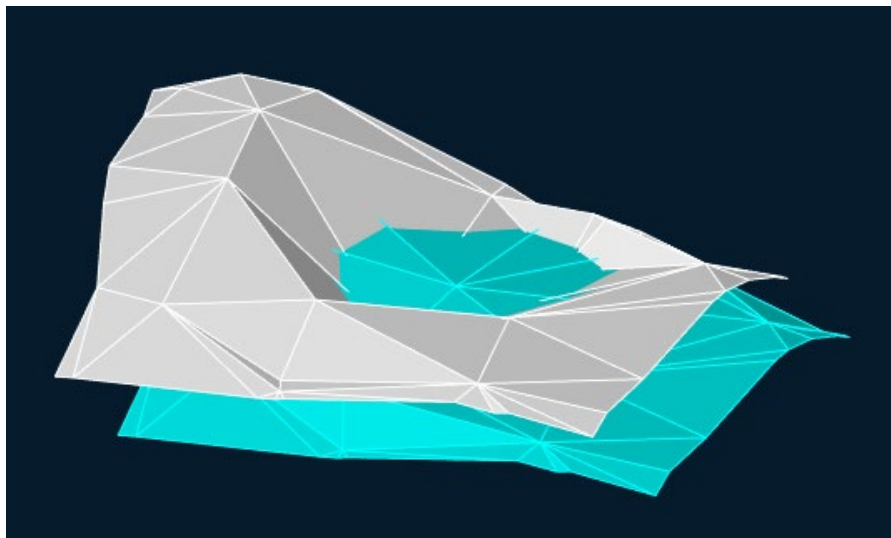

After running the command, first specify the surface created by design data, and then the actual surface (mesh or polyface mesh).

The command options are specified on the **Properties** toolbar.

**Options:**

<b>Type of calculation</b>	<p><b>Total volume</b> – a total volume of two surfaces will be calculated.</p> <p><b>Differenced volume</b> – cut and cover volume will be calculated.</p> <p><b>Balance volume</b> – difference of cover and cut volume.</p>
----------------------------	--

<b>Create models</b>	<b>Yes</b> – a new surface will be created for each type of calculation. Specify <b>No</b> so that new surfaces are not created.
<b>Create Mtext label in drawing</b>	<b>Yes</b> – label with the volume value will be created. <b>No</b> – the result will be displayed only in the command line.

For all types of calculations, you can customize colors of created models, if **Yes** is set for the **Create models** parameter.

### Command prompts:





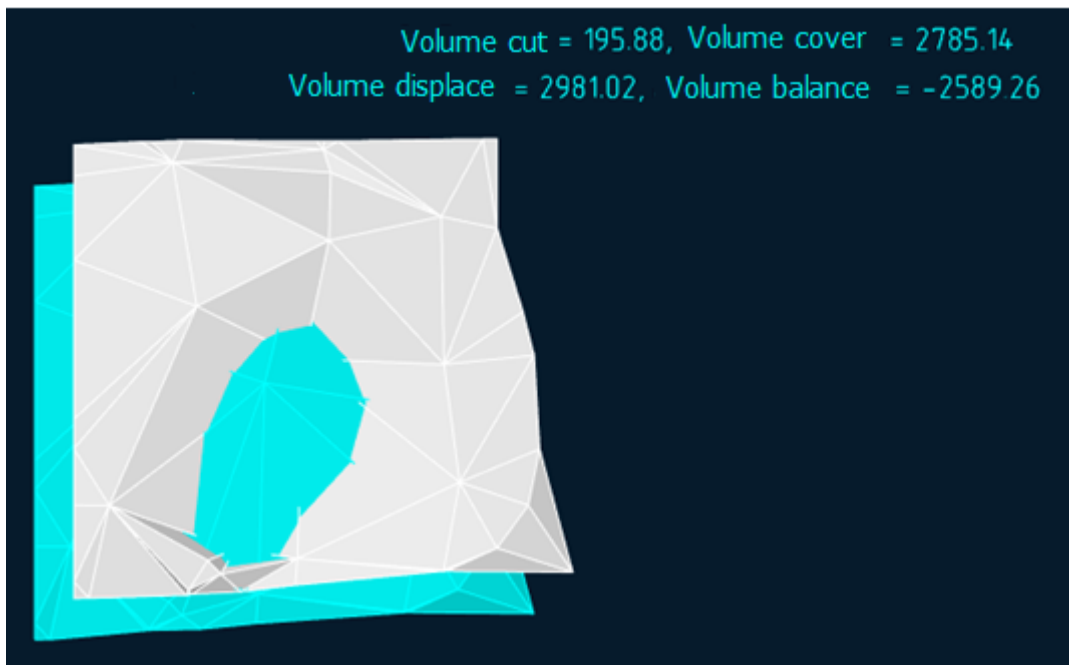

Apply changes <Yes> or  
[Yes/No]:

Yes – the volume will be calculated with the current settings.

No – if the settings have been changed, they are not saved. The volume will be calculated with the settings, that were displayed immediately after running the command.



## Calculating Surface Volume

-  Ribbon: **Topoplan – Texturing and calculations** >  **Surface Volume**
-  Menu: **Ground – Calculations** >  **Surface Volume**
-  Toolbar: **Textures and Calculations** >  **Surface Volume**
-  Command line: **NG\_SURFACE\_VOLUME**

The command allows to calculate volume of surface or surface area.

The command options are specified on the **Properties** toolbar.



**Options:**

<b>Volume</b>	<p><b>Total volume</b> – a total volume of a surface will be calculated.</p> <p><b>Differenced volume</b> – cut and cover volume will be calculated.</p> <p><b>Balance volume</b> – difference of cover and cut volume.</p>
<b>Define contour</b>	<p><b>Yes</b> – After applying the command options, specify the surface area in a drawing.</p> <p><b>No</b> – you do not need to specify a contour, the value of volume (volumes) will be calculated for the entire surface.</p>
<b>Create Mtext label in drawing</b>	<p><b>Yes</b> – label with the volume value will be created.</p> <p><b>No</b> – the result will be displayed only in the command line.</p>
<b>Define font size</b>	<p><b>Relative to contour</b> – size according to the mesh or contour.</p> <p><b>Fixed</b> – fixed size.</p> <p><b>On screen</b> – manual indication of size.</p>







**Command prompts:**

Apply changes <Yes> or [Yes/No]:

Yes – the volume will be calculated with the current settings.

No – if the settings have been changed, they are not saved. The volume will be calculated with the settings, that were displayed immediately after running the command.

## Calculating Area

-  Ribbon: **Topoplan – Texturing and Calculations** >  **Surface Area**
-  Menu: **Ground – Calculations** >  **Surface Area**
-  Toolbar: **Textures and Calculations** >  **Surface Area**
-  Command line: **NG\_SQUARE**

The command is designed to define the area of a surface patch. The objects for calculation are **Submesh** or **Polyface mesh**.

The command options are specified on the **Properties** toolbar.

**Command prompts:**

Apply changes <Yes> or [Yes/No]:

Yes – the area will be calculated with the current settings.

No – if the settings have been changed, they are not saved. The area will be calculated with the settings, that were displayed immediately after running the command.

Specify closed contour

Specify a surface patch in a drawing. It is the most convenient to specify contour in

visual styles with filling.

To end, press **ENTER**.

The result will be displayed in the command line. The total area, area in the projection to XY plane, area in the projection to XZ plane, area in the projection to YZ plane will be calculated. The values of areas are given in the drawing units.

## Surface Difference



Ribbon: **Topoplan – Texturing and Calculation** >  **Surface Difference**



Menu: **Topoplan – Calculation** >  **Surface Difference**



Toolbar: **Texturing and Calculation** >  **Surface Difference**



Command line: **NG\_HEIGHT\_DIFFERENCE**

The **Surface Difference** command creates a new surface by subtracting one surface from another.

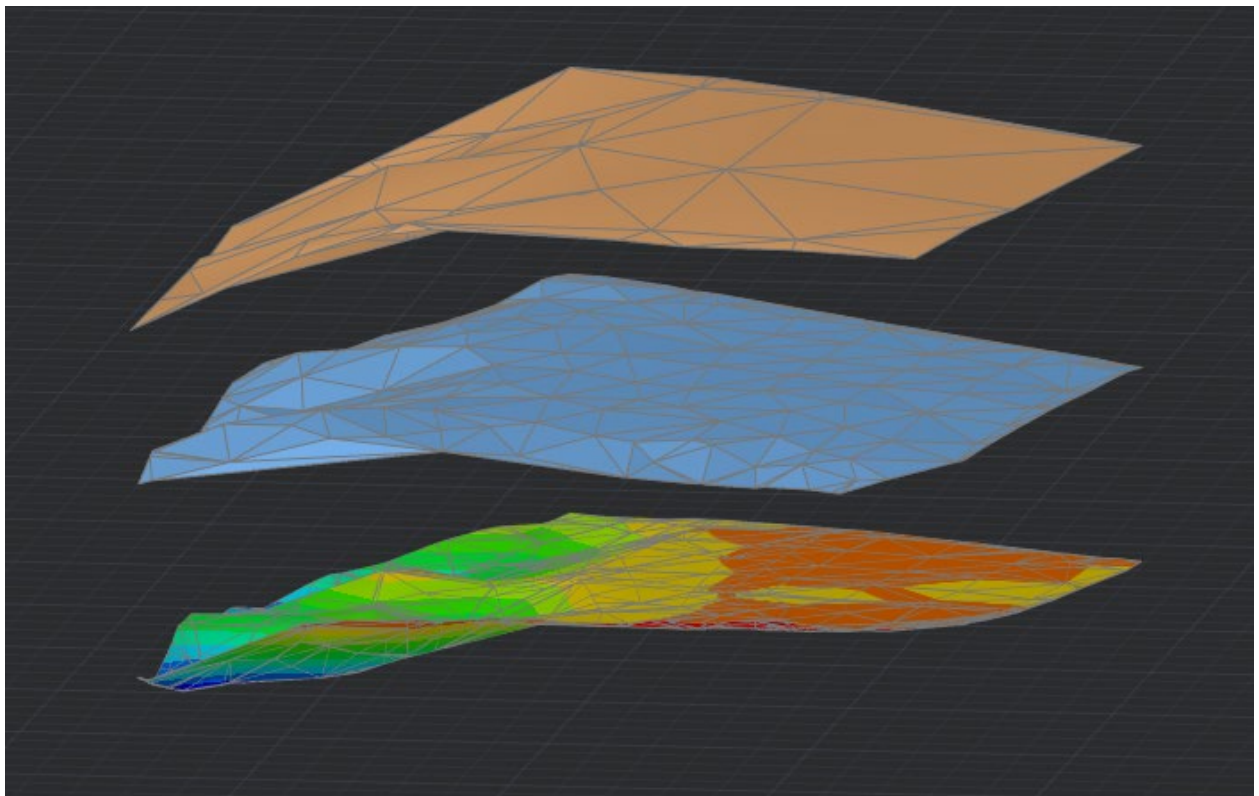

The command has no options.

## Forming a Legend









Ribbon: **Topoplan – Texturing and Calculation** >  **Formation of a Legend**

 Menu: **Topoplan – Calculations >  Formation of a Legend**

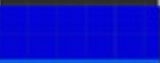
 Toolbar: **Texturing and Calculation >  Formation of a Legend**

 Command line: **NG\_PAINT\_ELEVATION\_LEGEND**

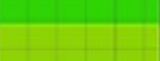
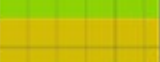
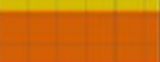
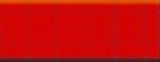
The **Formation of a Legend** command outputs a legend into the drawing in the form of a dwg table for the selected network, colored by height.

Surface Elevation Ranges, Meters			
Number	Lower Limit	Upper Limit	Color
1	25.7632	27.7648	
2	27.7648	29.7664	
3	29.7664	31.768	
4	31.768	33.7696	
5	33.7696	35.7712	
6	35.7712	37.7728	
7	37.7728	39.7744	
8	39.7744	41.776	
9	41.776	43.7776	
10	43.7776	45.7792	

### Command prompts:

Select objects or  
[?]:

Specify first corner

Specify second  
corner

Select the mesh you want to create a legend for.

Specify the first corner of the table in the drawing.

Specify the second corner of the table in the drawing.

## Drawing Context

### Conventional Signs

 Ribbon: **Topoplan – Maps >  Conventional signs**

 Menu: **Topoplan – Maps >  Conventional signs**

 Toolbar: **Maps** >  **Conventional signs**

 Command line: **WS\_CLASSIFICATOR**

The **Conventional signs** functional bar is used to insert conventional signs into a drawing (for drawing topoplans of scales 1:500, 1:1000, 1:2000, 1:5000).

Before drawing conventional signs, select one of the topographic scales: 1:500, 1:1000, 1:2000 or 1:5000, in accordance with the required scale of the finished drawing.

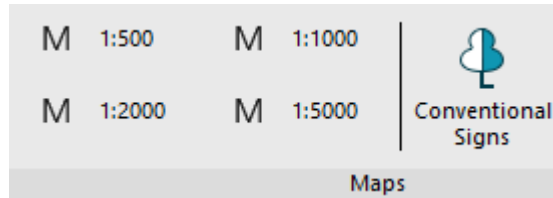

When changing the topographic scale, a proposal appears to change the scale for geopoints inserted into the drawing and the conventional signs of the classifier (blocks).

### Appearance of the bar

The bar elements are structured:

- by thematic sections;
- In alphabetical order.

The letter **T** is used after the name for point Signs, for linear ones – letetr **L**. Signs consisting of segments in the form of a single line are created as **Polylines** objects, if the segments consist of several lines, then **Multilines** are created.

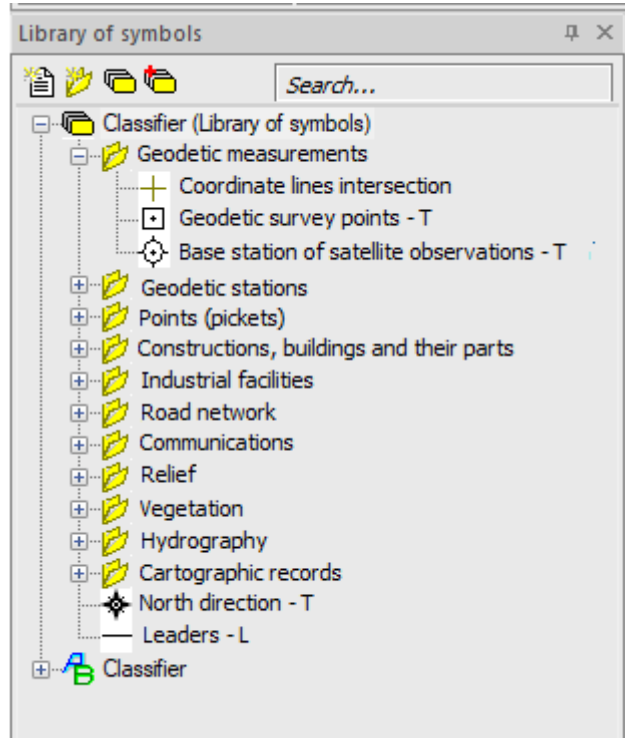

### Search for a conventional sign

To quickly search for an element, you need to enter its name or part of the name in the upper text field of the bar. As you type, only those elements whose name contains the entered expression remain in the list of conventional signs.

### Placing a conventional sign in a drawing

1. Double-click the left mouse button on an item in the list.
2. Specify the insertion point of the element in the working area of the drawing or enter its coordinates in the command line.
3. If you need to set paste options for the element, then enter them in the command line or in the dialog box that opens.

**Point conventional signs** – Specify the insertion point and enter attribute values, if any.

**Linear conventional signs** – sequentially set the points of a polyline/multiline in the drawing.

The capabilities of the **Conventional signs** bar are not limited to inserting signs from an existing classifier. It is also possible to create your own signs or connect third-party libraries. To do this, use the buttons at the top of the bar.

 **Create element.** Creating a new element of the library.

 **Create section.** Creating a folder for thematic ordering of library items.

 **Create library.** Prompts for a name in the command line and creates a new empty library with two ordering options: thematic and alphabetical.

 **Attach/detach library.** Opens a dialog box that allows you to enable/disable the display of existing libraries in the **Conventional signs** bar. The source library cannot be disabled.

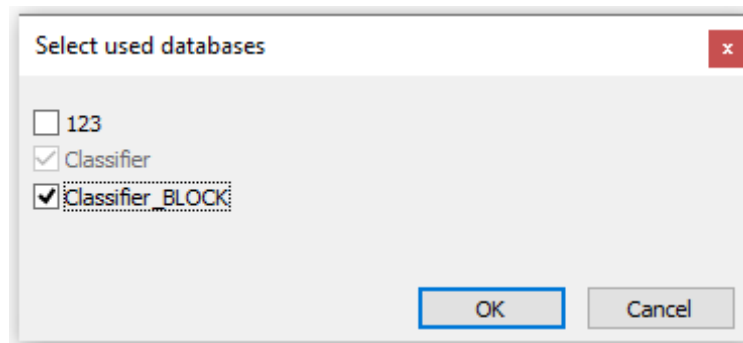

Work with the sign library is described in more detail in the Create library section.

## Creating Customized Library of Conventional Signs

### Structure of a Library of Conventional Signs

- Files of the library of conventional signs (hereinafter - CS) re located in the folder: "C:\Users\\*USER NAME\*\appdata\Roaming\Nanosoft AS\nanoCAD x64 21.0\classifier\";
- The "\\icons" folder contains icons for symbols in the **Library of Sings** bar;
- The "\\support" folder contains databases of blocks, linetypes, multilines, forms;
- The DwgLib.dwg file in the "\\support" folder contains blocks of the preset library; the Topo500.mln, Topo500.lin, ltypeshp.shx files store the description of linetypes, multilines and forms;
- The Classifier.xml file contains the description of the preset library, which is loaded into the bar by default. It cannot be disabled, but can be edited;
- When adding new libraries in the form of \*.xml files, their connection will become available through the interface of the **Library of Sings** bar.

## Creating a Customized Library Using Teplate

Put the "Additional conventional signs.xml" template file in the "c:\Users\\*USER NAME\*\appdata\Roaming\Nanosoft AS\nanoCAD x64 22.0\classifier\" folder

Main elements of the XML file:

- `group` – a folder (or subfolder) in the bar tree;
- `object` – object (point or line CS). The description of classifier objects is discussed below.

Open the **Library of Signs** bar (WS\_CLASSIFICATOR command) and connect the additional library:

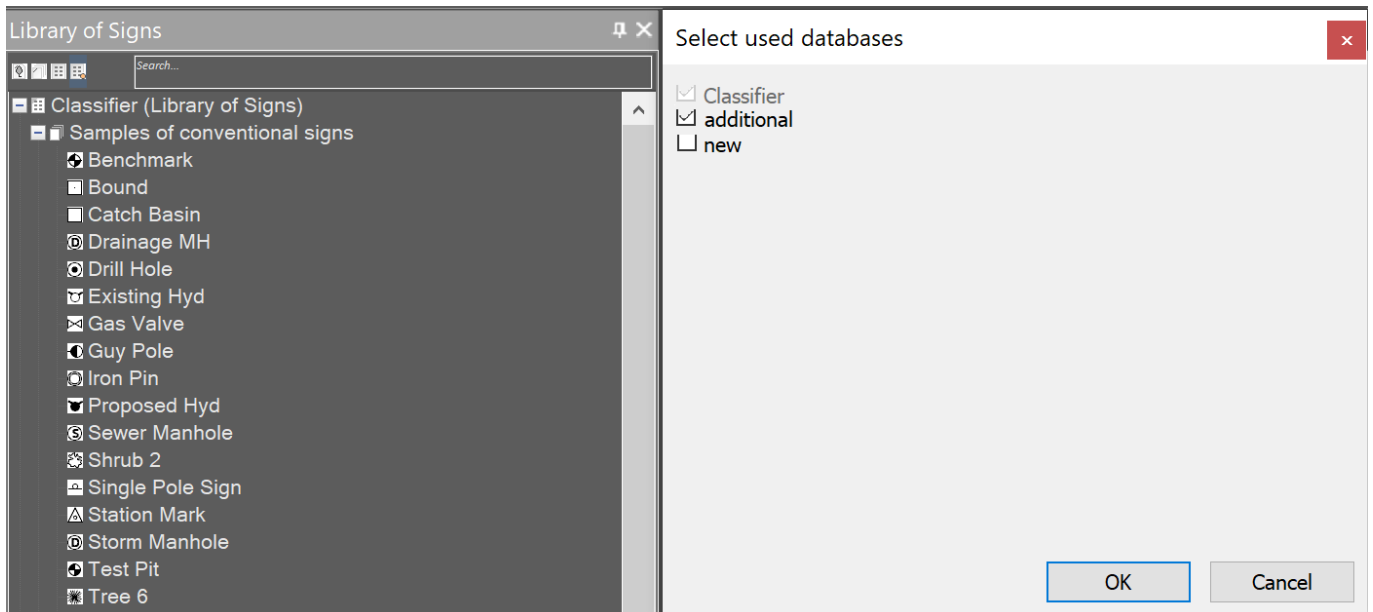

## Adding Conventional Signs to the Library

### Adding point signs (blocks)

Open the drawing from which you plan to add conventional signs.

In the bar tree select the section to which you want to add a new conventional sign. If, when creating an element, the name of the library is selected in the bar tree, then the CS will be added to the classifier without a folder (to the root of the tree).

Click the  **Create elements** button.

Enter the element information in the command line:

- element name in the classifier;
- name of the layer on which the element should be placed when it is inserted into the drawing;
- possibility to scale the element;
- type of object.

In the drawing, select the objects that make up the element and set the insertion point:

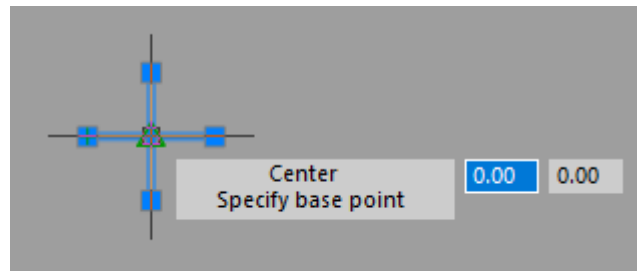

The new object will appear in the list of conventional signs of the bar:

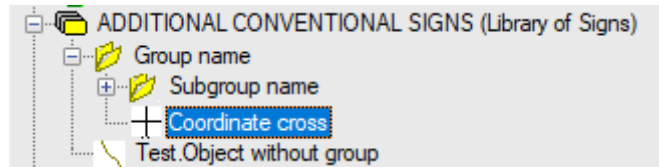

Description of a point sign in XML file looks like:

```
<object name="Coordinate cross" id="60002" cmd="block" internal="WS_Point"
args=""
ScaleMode="fixed" CType="block">
<params>
<layer>Design</layer>
<source>60002</source>
<description>Coordinate cross</description>
</params>
</object>
```

Required elements:

- `layer` – defines the name of the layer that will be created when inserting the CS;
- `source` – name of the DWG file in which the block and block name are stored, respectively;
- `name` – defines the sign name in the bar tree;
- `internal` – nanoCAD command called when inserting a conventional sign. Values:
  - `WS_Point` – command for inserting a point CS;
  - `WS_Line` – command for drawing a polyline or multiline.

Using this, you can add a sign description directly to the XML file.

### ***Adding line signs (polylines and multilines)***

To add a new conventional sign in the form of a polyline, first add a description of this polyline to the Topo500.lin file.

To add a CS as a multiline, add a description to the Topo500.mln file.

Adding line conventional signs through the bar interface is not yet provided, so you need to edit the XML file directly. The description of the line sign in the XML file looks like this:

```
<object name="Line sign" id="NN" cmd="block" internal="WS_Line" args="">
<params>
<layer>Line sign</layer>
<grStyle>NN</grStyle>
<lweight>60</lweight>
<color>10</color>
</params>
</object>
```

Required elements:

- `layer` – defines the name of the layer that will be created when inserting the CS;

- `grStyle` – the name of the line style in the LIN (MLN) description file;
- `lweight` – line weight of the conventional sign;
- `color` – line color of the conventional sign.

The **useColors** attribute at the beginning of the XML file is responsible for using the color. Values:

- `true` – conventional signs will be inserted taking into account the specified color;
- `false` – all new signs will be inserted in the default color (by layer).

nanoCAD has built-in editors for line types and multiline styles (LINTYPE and MLSTYLE commands), in which you can conveniently change the existing lines or create new ones in Topo500.lin and Topo500.mln files. These editors also allow you to specify the line style name for manual editing of XML files.

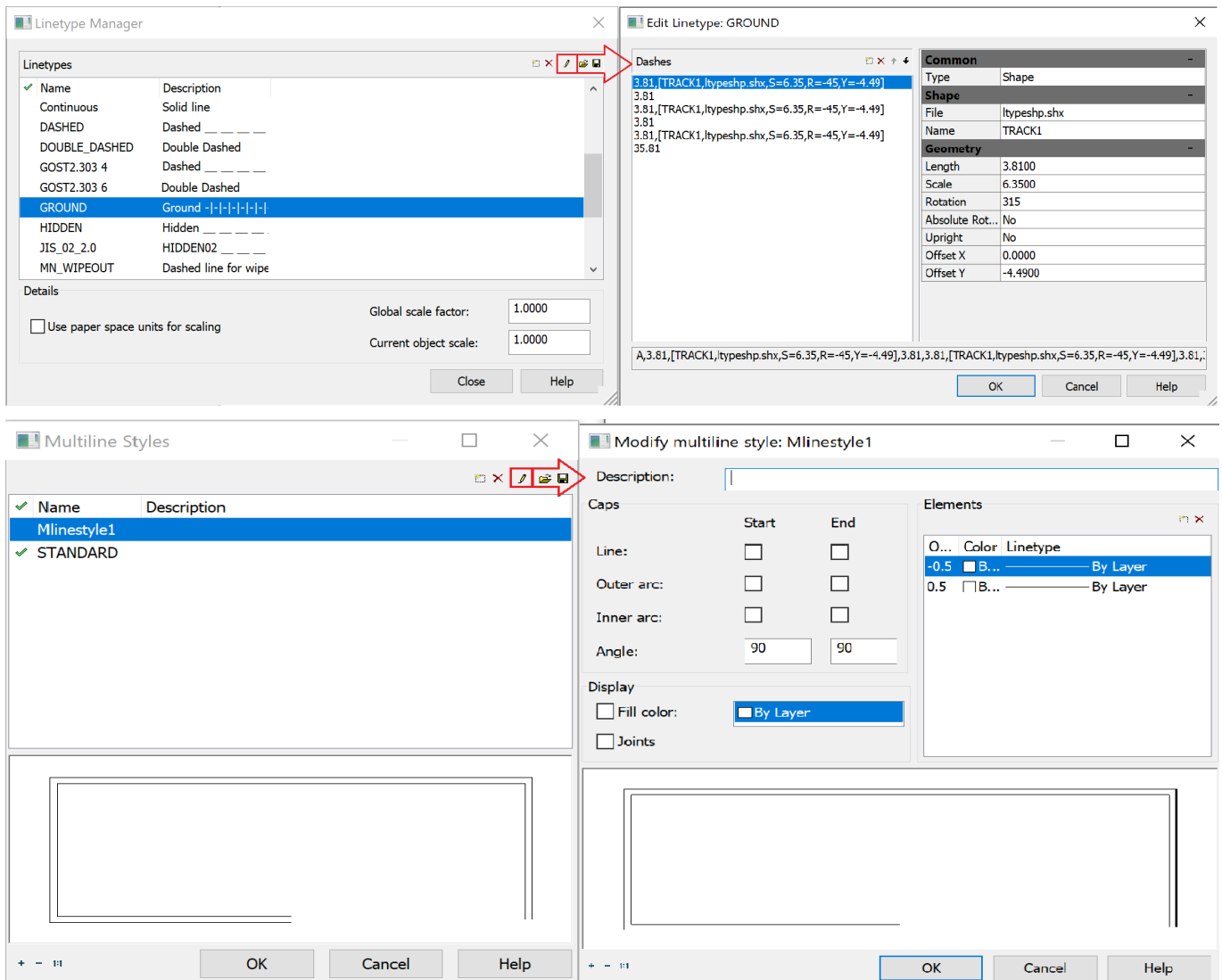

## Editing the Existing Conventional Signs of the Library

To edit point sign graphics, open the context menu by clicking on the bar, and select **Edit** -> **Graphical representation**:



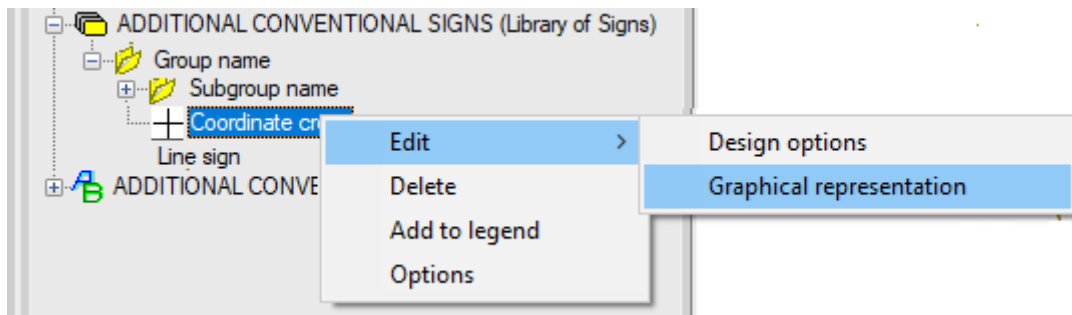

Upon the prompt `Select objects or [?]:` specify elements of a future sign in the drawing and set its base point:

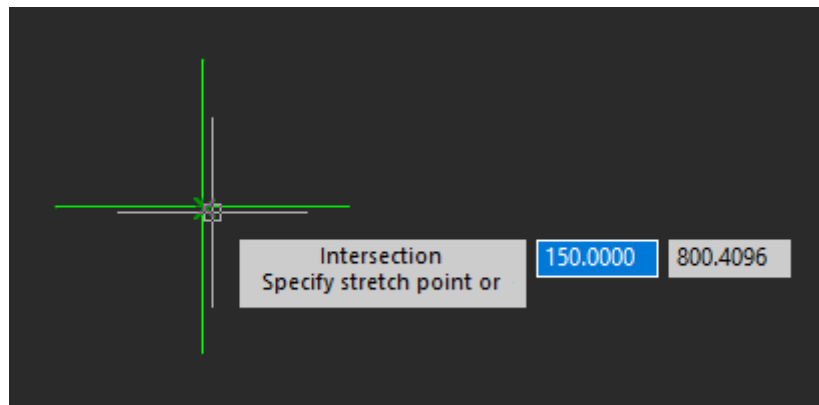

Sign editing is completed. In the library tree, the CS icon will be updated:

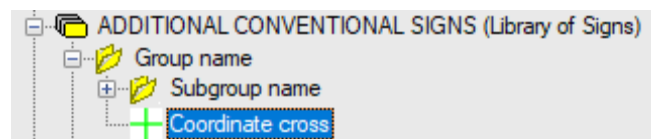

To delete signs from the bar, use the context menu:

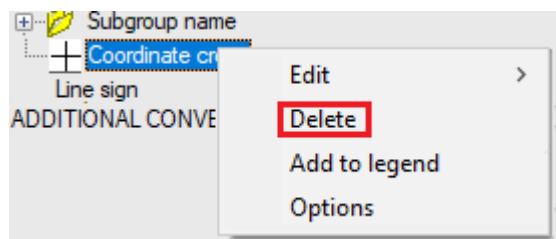

Using the above format for describing a point CS in an XML file, you can edit the sign in the XML file directly by replacing the sign's name (if there is a ready-made file with such a block) or delete the object completely.

Editing the outline of line conventional signs through the bar interface is not yet provided, to change such signs you should edit the XML file.

When manually creating or editing sign graphics via the XML file description, the sign icons for the bar should also be created manually. In order for objects to get an icon, it is necessary to create a BMP file with a sign image (16x16 pixels in size and 32 bit color depth) and put it in the "\\icons" folder. The name of the BMP file should match the element name in the description of the sign (block, line type, multiline). After restarting nanoCAD, the icons will appear in the bar.

## Topographic Hatches



Ribbon: **Topoplan – Situation** >  **FillShapes**

 Menu: **Topoplan – Maps >  Topographic Hatches**

 Toolbar: **Maps >  Topographic Hatches**

 Command line: **FILLSHAPES**







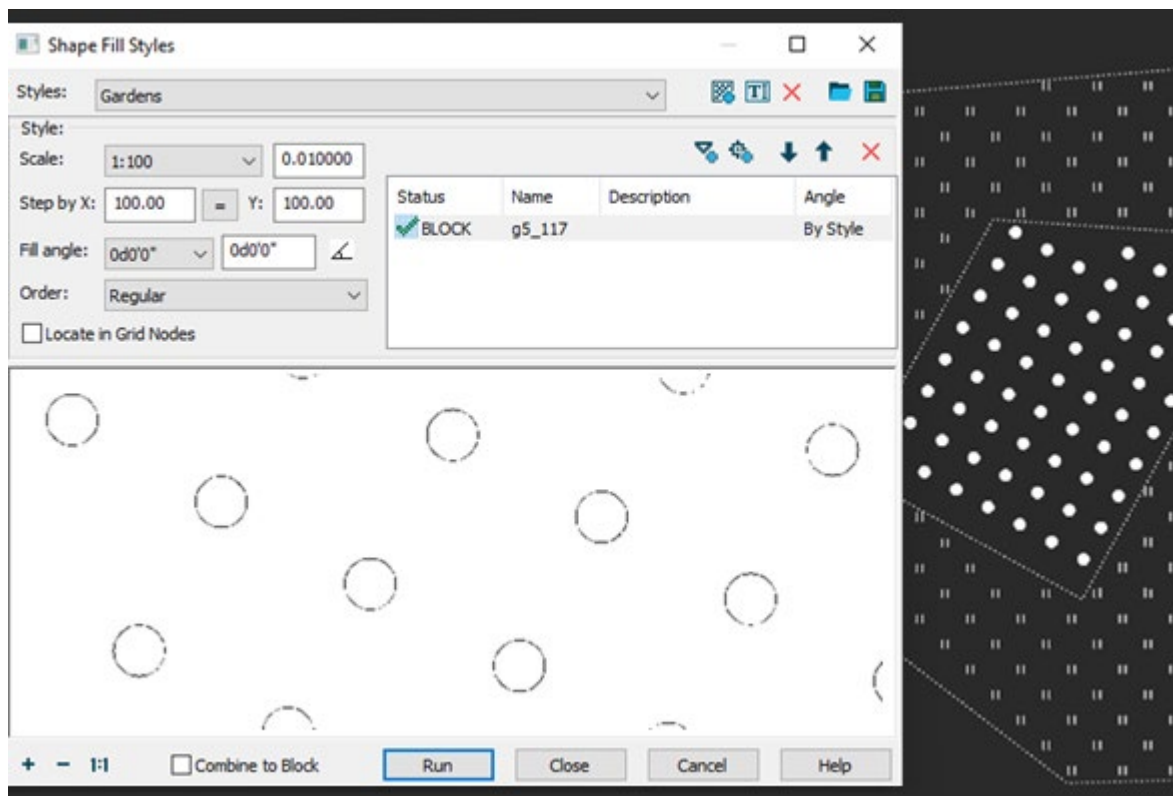

The **FillShapes** command fills contours with conventional signs on a regular, chess or random grid. Conventional signs can be represented by a combination of blocks from the sign library and SHX shapes.

The command can be used to designate forest areas or wetlands in topographic drawings with conventional signs (CSs). Unlike hatching, the **FillShapes** command allows you to set the distance between rows and columns of shapes, as well as the rotation angle of the shape in the fill (not to be confused with the rotation angle of the fill itself).

The shape fill does not have associativity; i.e. changing the outline of a filled area (for example, using grips or the **Stretch** command) does not automatically update the fill.

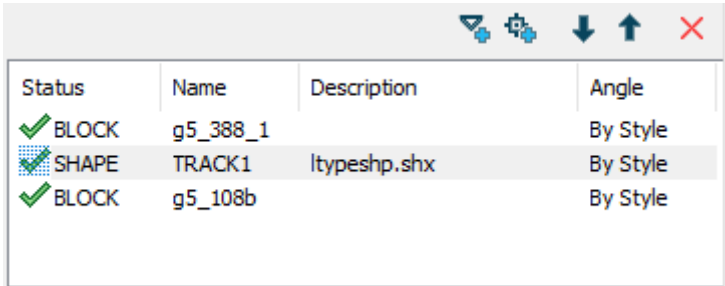

**Options:**

<p><b>Styles</b></p>	<p>Topographic hatch settings can be saved to styles for later loading and use. In the drop-down list, you can select all styles in the document for editing.</p> <ul style="list-style-type: none"> <li>  <b>Add Fill Style</b> – create a new style based on the current settings, specifying the name of the new style;         </li> <li>  <b>Rename Fill Style</b> – rename the current editable style;         </li> <li>  <b>Delete Fill Style</b> – delete the current style;         </li> <li>  <b>Load Fill Styles</b> – loading styles into a document from a file (dwg, dxf, dws, dwt);         </li> <li>  <b>Save Fill Styles</b> – save styles to a file (dwg, dxf, dws, dwt).         </li> </ul>																
<p><b>Topographic hatch composition</b></p>	<p>The list of elements of the current topographic hatching. You can add SHX shapes and sign library element blocks as elements.</p> <div data-bbox="646 898 1374 1182" data-label="Image">  <table border="1"> <thead> <tr> <th>Status</th> <th>Name</th> <th>Description</th> <th>Angle</th> </tr> </thead> <tbody> <tr> <td>✓ BLOCK</td> <td>g5_388_1</td> <td></td> <td>By Style</td> </tr> <tr style="background-color: #e0e0e0;"> <td>✓ SHAPE</td> <td>TRACK1</td> <td>ltypeshp.shx</td> <td>By Style</td> </tr> <tr> <td>✓ BLOCK</td> <td>g5_108b</td> <td></td> <td>By Style</td> </tr> </tbody> </table> </div> <p>Sometimes there may be a combination of vegetation, soils and farmland in one area. Then it may be necessary to fill the area unevenly with several types of conventional signs (from 2-3 to 4 different types).</p> <p>The order of the element in the list determines the order in which it is placed in the hatch. You can change the order of elements in hatching using the   buttons by moving the element up or down in the list. The  button can be used to remove an element from the current hatch.</p>	Status	Name	Description	Angle	✓ BLOCK	g5_388_1		By Style	✓ SHAPE	TRACK1	ltypeshp.shx	By Style	✓ BLOCK	g5_108b		By Style
Status	Name	Description	Angle														
✓ BLOCK	g5_388_1		By Style														
✓ SHAPE	TRACK1	ltypeshp.shx	By Style														
✓ BLOCK	g5_108b		By Style														

 **Add Shape**

Adding an SHX shape as a hatch element. Opens the **Choose Shape** dialog where you can select the desired shape from the existing SHX files.

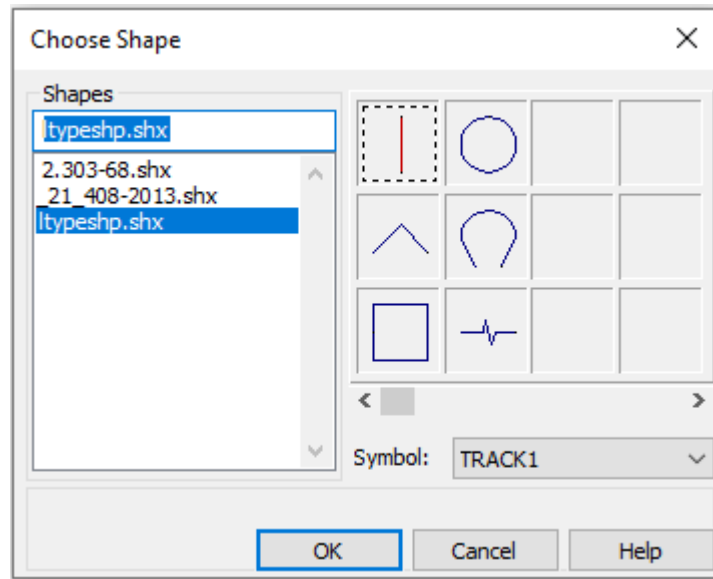

SHX files are located in the folder specified in the **Default directories** section of the **Options** dialog.

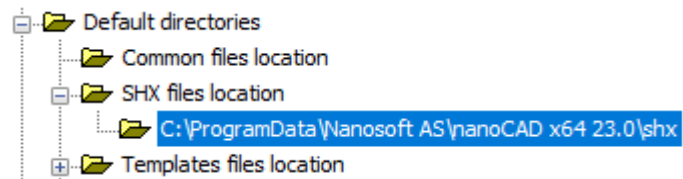

 **Add Block**

Adding a block as a hatch element.

In order to display all CS blocks of the **Conventional Signs** bar in the dialog, first insert at least one conventional sign into the drawing. You can search for a block by entering in the search field the numerical designation of the block:

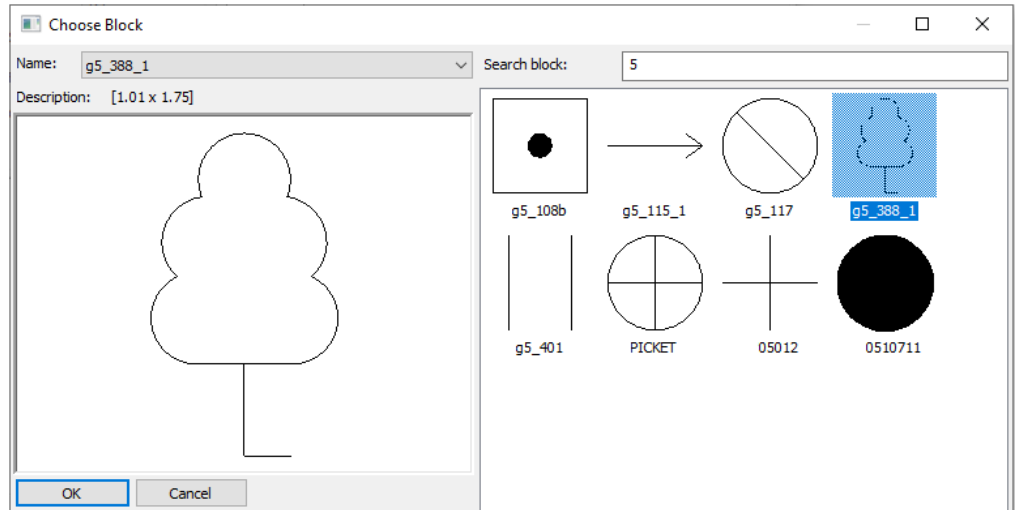

alphabetic description,

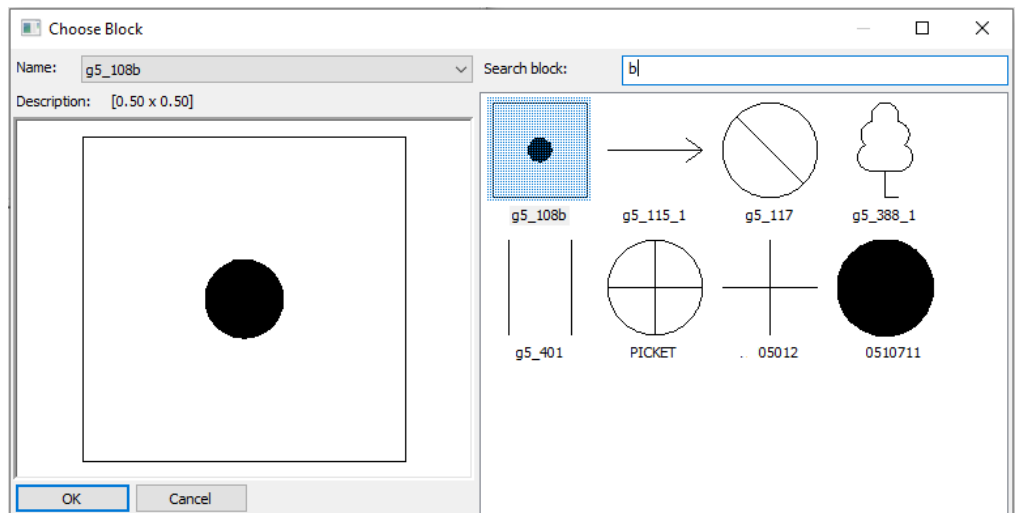

or even block size values displayed in square brackets in the current units after the alphabetic description:

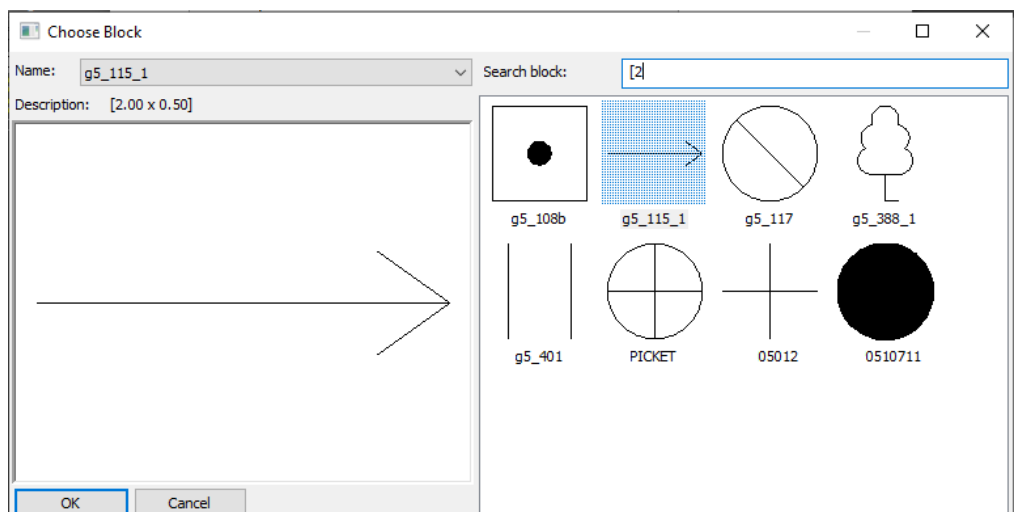

**Scale**

The scaling factor for the size of hatch signs.

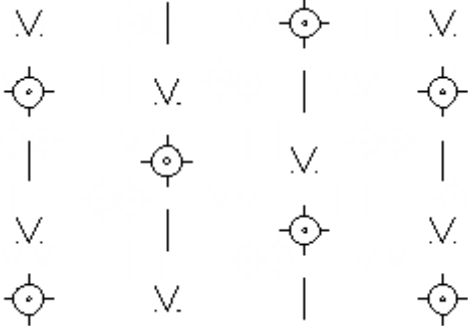
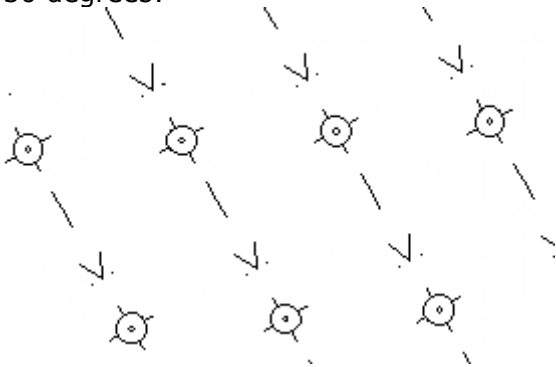
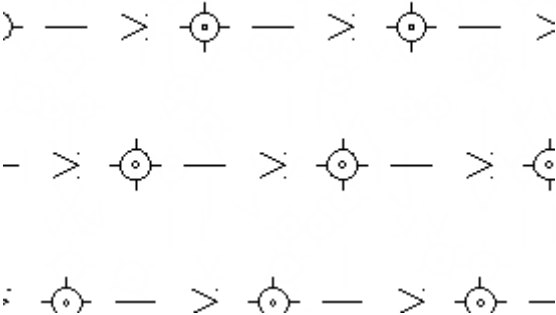
<b>Step by X</b>	Horizontal offset distance of hatch elements.
<b>Y</b>	Vertical offset distance of hatch elements.
=	Copies the X step to the Y box
<b>Fill angle</b>	<p>Angle of hatch rotation. You can select the desired angle value among the fixed ones from the drop-down list, enter your own angle in the field using the keyboard, or specify the angle on the drawing after pressing the  button.</p> <ul style="list-style-type: none"> <li>0 degrees:            </li> <li>30 degrees:            </li> <li>90 degrees:            </li> </ul>

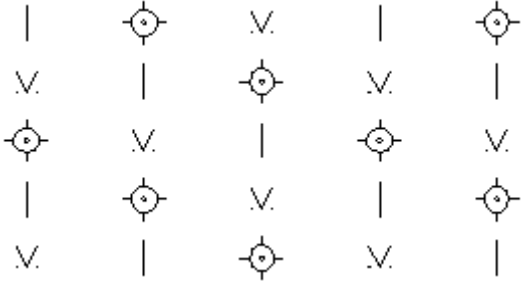
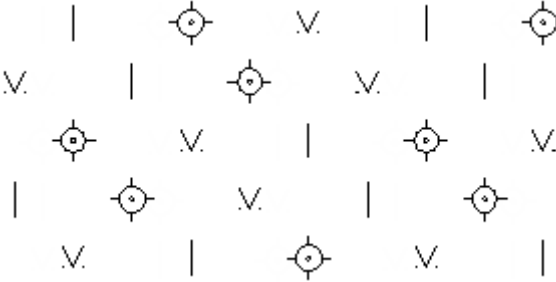
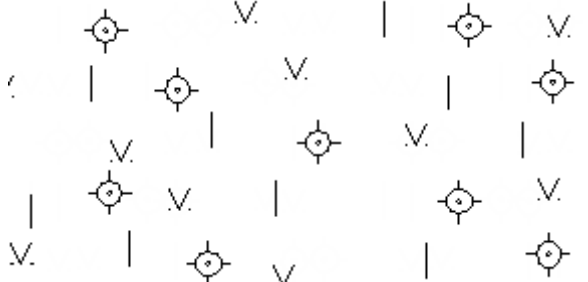
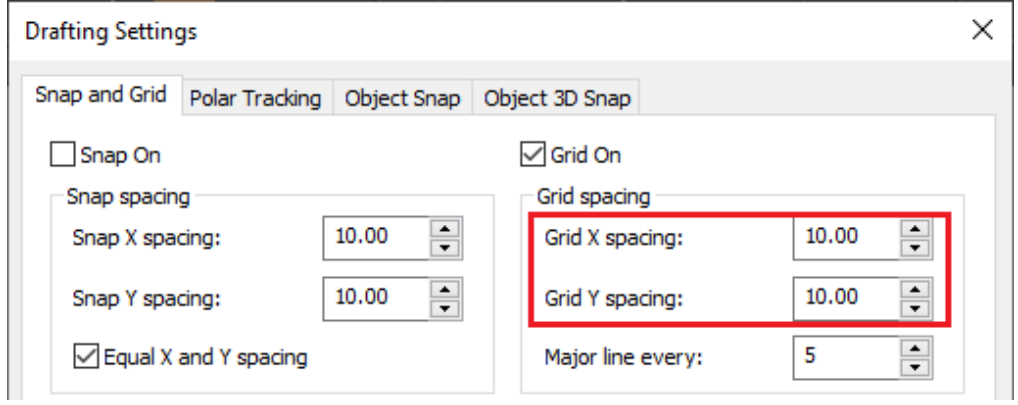
<p><b>Order</b></p>	<p>The principle of alternating elements relative to each other.</p> <ul style="list-style-type: none"> <li> <p><b>Regular</b> hatching order of three elements</p>  </li> <li> <p><b>Chess</b> order of the same hatching elements</p>  <p>The chess order of filling with signs is usually used to designate grass vegetation, nursery farms, agricultural lands.</p> </li> <li> <p><b>Random</b> order the hatching elements</p>  <p>The irregular order of filling with signs is used in the designation of all types of natural origin forests.</p> </li> </ul>
<p><b>Locate in Grid Nodes</b></p>	<p>Ignores some previous settings and places hatch elements at grid nodes. The step is taken from the grid step specified in the <b>Drafting Settings</b> dialog. Rotation angle = 0.</p> 
<p><b>Combine to Block</b></p>	<p>Allows you to create a single block from all the elements that make up the fill. The block can later be split into separate objects with the <b>Explode</b> command.</p>

After setting all the hatching parameters, press the **Run** button and click inside all the closed contours to be filled.

## Importing Geo-linked Rasters

 Ribbon: **Topoplan – Situation** >  **Geo-Rasters Import**

 Menu: **Topoplan – Maps** >  **Importing Geo-linked Rasters**

 Toolbar: **Maps** >  **Importing Geo-linked Rasters**

 Command line: **NG\_IMPORT\_RASTERS**

The command is intended for batch loading of geo-linked rasters in TIF, ECW formats.  
The command has no options.

## Import and Export

### Importing Geopoints

 Ribbon: **Topoplan – Import/Export** >  **Import geo-points**

 Menu: **Ground – Import/Export** >  **Import Geo Points**

 Toolbar: **Import/Export** >  **Import Geo Points**

 Command line: **NG\_IMPORT\_POINTS**

The command is designed to import text files from CSV, SDR (Sokkia), XYZ and TXT. In the import dialog you can configure the rules for interpreting and uploading file contents.



Import. Files opened: [1]

**File**

Open file

Special

Encoding: windows-1251 | New line char: \n | Content Start Line: 1 | Comment: //

Separator

. dot |  , comma |  \t tabulation |  ; semicolon |  space

Other |  Regular Expression

**Data**

1	515966.925	4776857.852	-6.729	2	2	2	2	2	2
2	515953.324	4776792.705	20.981	3	3	3	3	3	3
3	515968.340	4776716.455	47.044	4	4	4	4	4	4
4	515916.144	4776883.108	-12.578	5	5	5	5	5	5
5	515917.966	4776767.925	18.347	6	6	6	6	6	6
6	515872.289	4776854.047	-8.046	7	7	7	7	7	7

**UDP classification** | **Filters**

+ |  -

+ |  -

**Result**

	Name	X (East)	Y (North)	Z	Code
1	1515966.9254776857.852-6.729222222				
2	2515953.3244776792.70520.981333333				
3	3515968.3404776716.45547.044444444				

**Drawing objects**

Simple Point | 0 | By Layer

Text style: Line\_GUGK

Name | 0 | T | By Layer

Elevation | 0 | T | By Layer

Code | 0 | T | By Layer

Create polyline |  Closed | 0 | By Layer

Current profile: Default |  + |  -

EPSG Transformation ...

Ok | Cancel | Help | Additional Options

**Options:**

<p><b>Open file</b></p>	<p>Open text file CSV, SDR (Sokkia), XYZ and TXT to import geodata. You can open multiple files at the same time.</p>
-------------------------	---

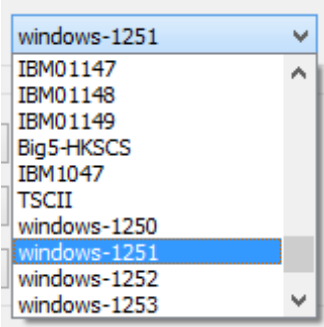
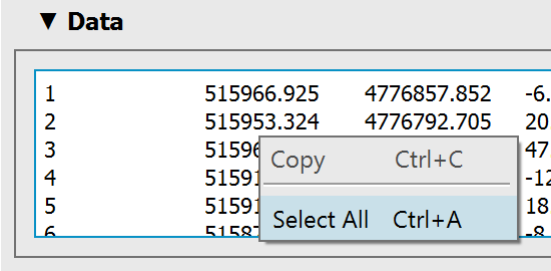

<p><b>Encoding</b></p>	<p>Encoding of the imported text file.</p> 
<p><b>New line character</b></p>	<p>Allows you to override the newline character. The default character is \n.</p>
<p><b>Content start line</b></p>	<p>Line number of significant content, if the file beginning contains any service information, except for point coordinates.</p>
<p><b>Comment</b></p>	<p>Specifies the character that is used to comment lines. Commented lines are not considered as data during import. If there are no comments in the file, then leave the field blank. The default character is \\..</p>
<p><b>Separator</b></p>	<p>Specifies a character that separates data in a text file. You can choose both predefined ones (period, comma, semicolon, tab character, space), or set any other, if necessary, using regular expressions.</p>
<p><b>Raw data</b></p>	<p>Preview of text file data. Selected data can be copied.</p> 

## UPD classification

You can add custom properties to points with the  button. You should specify the type (integer, float, or string) and name.

▼ UDP classification



Evaluation Float ▾



A new empty column with the name of the custom parameter appears in the **Result** table. Drag this column heading onto the heading of the column you want it to match.

▼ UDP classification

Turning Integer ▾

 

▼ Filters

▼ Result

	Name	X (East)	Y (North)	Z	Code	Turning
1	1515966.9254776857.852-6.729222222					

You can delete unnecessary custom properties with the  button. Upon the points are imported, custom properties can be viewed and edited in the **Properties** bar just like other properties.

Label Visible	Yes
<b>COGO Point Geometry</b>	—
Easting	3877.209
Northing	-220.4796
Elevation	211.639
<b>User-defined properties</b>	—
Evaluation	312.062

If the table has more than 5 columns, then a new column is not created, but the name of the 6th is overwritten.

▼ Result

	Name	X (East)	Y (North)	Z	Code	New	7	8
1	M13	-26.8440	5.5215	-0.5535	0	6	7	
2	M01	0.4949	3.0738	-1.7693				
3	M02	0.7159	27.9606	-1.8116				

▼ Drawing objects

## Filters

You can exclude data from import not only manually by deleting cells from the Result table, but also by setting filters. For example, you can exclude from import all points with heights below 52 (column Z) and with a number greater than 350 (column Name).



**Filters**

Z  Regular Expression >52

Name  Regular Expression <350

+ -

After adding the filter with the  button, in the drop-down list, select the column by which all imported data will be filtered. Then set the value that the column data should satisfy. The rest of the lines will be excluded from import. Hovering over a filter displays a tooltip with sample values.

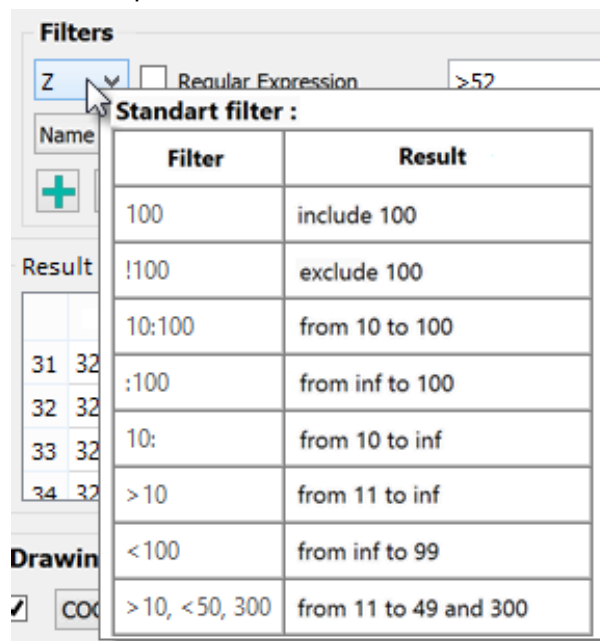

**Filters**

Z  Regular Expression >52

Name  Regular Expression <350

+ -

**Standart filter :**

Filter	Result
100	include 100
!100	exclude 100
10:100	from 10 to 100
:100	from inf to 100
10:	from 10 to inf
>10	from 11 to inf
<100	from inf to 99
>10, <50, 300	from 11 to 49 and 300

It is recommended to set filters only after correct data typing in the **Result** section.

## Result

The table specifies the correspondence of the text file columns to certain data types: point X, Y and Z coordinates, numbers, point descriptions. The column heading displays the data type. In case of incorrect initial data typing, you can drag one column to another by the header, mutually changing the data in these columns.

	Имя	X (Восток)	Y (Север)	Z	Код
1	bw1	0.1958	5.5875	0.1541	
2	bw2	0.7500	5.5198	-0.3934	
3	bw3	1.0919	5.4768	-1.0567	
4	bw7	-1.2071	-0.9197	0.1589	

You can delete selected cells, rows, or columns. Multiple selection is supported using **SHIFT** and **CTRL**. Rows or columns are selected by clicking on the heading. Before manually deleting data, it is recommended to filter it out using filters.

You can also edit the data after double-clicking on a cell.

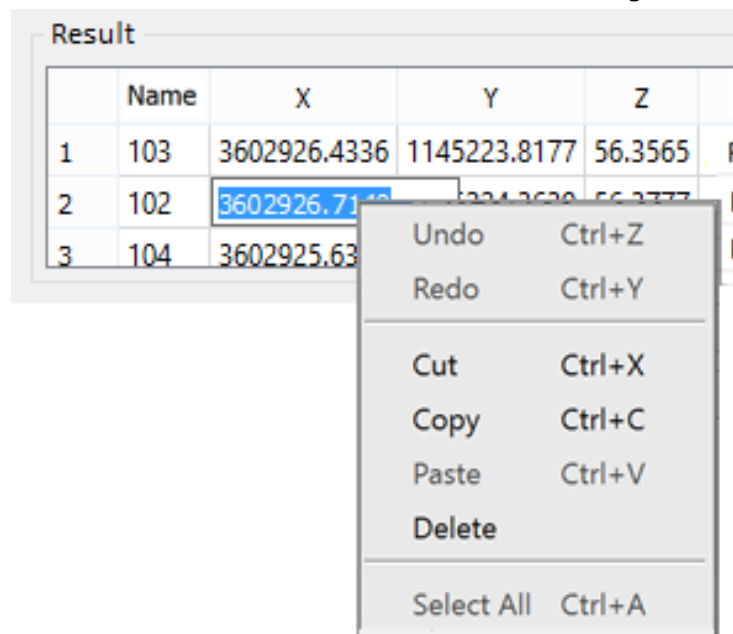

The screenshot shows a window titled "Result" containing a table with columns "Name", "X", "Y", and "Z". The cell containing the value "3602926.71" in the X column of the second row is selected. A context menu is open over this cell, listing the following actions and their keyboard shortcuts:

- Undo (Ctrl+Z)
- Redo (Ctrl+Y)
- Cut (Ctrl+X)
- Copy (Ctrl+C)
- Paste (Ctrl+V)
- Delete
- Select All (Ctrl+A)

## Drawing objects

The section determines the form objects the geopoints should be imported from an external file (that is, by what objects they will be represented in the drawing). And also what titles the point label will consist of, and what design they will have.

You can import geodata as:

- Common **Point** objects with labels as text objects;
- **Blocks** (like blocks from the **Conventional sign** bar)
- Objects of the **Geopoint** type with a label.

In case of importing data in the form of **COGOpoint** object, specify a group for them in the drop-down list below.

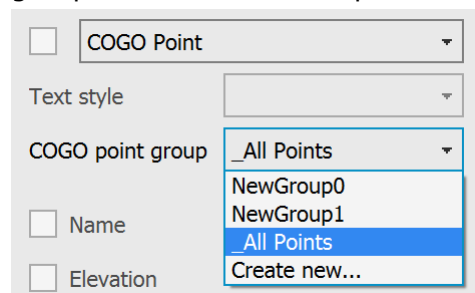

The list contains only groups of geopoints that exist in the current drawing. To create a new group, select the **Create new** option and enter a name for the new group.

If the **Block** was selected, the imported points will be presented as block inserts with single-line attributes to display label titles. To do this, a new block will be created in the drawing. The conventional sign for the point marker will be taken from the block in the dropdown list below.

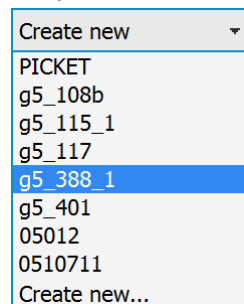

Only the blocks that already exist in the current drawing are available in the list. To make the blocks of the **Conventional signs** toolbar available, insert at least one conventional sign into the drawing.

When importing, it is possible to select a block for the marker and the main block (marker + attributes). If the main block existing in the drawing is selected, you can add block attributes in the property classification (they will appear as columns in the table for further editing). The block selected for import is analyzed for the presence of attributes. Next, select an attribute that, when imported, will be filled with data from the point file. When adding an attribute, one of the existing parameters should be selected from the proposed ones (attribute, udp, rotation); if a new attribute is created, then the "=" sign should not be there.

▼ **UDP classification**

=ATTR:ИМЯ

+ -

▼ **Result**

	=ATTR:NAME	X (East)	Y (North)	Z
1	M01	-31.0783	11.9636	-1.5768
2	M02	-19.5381	17.5320	0.7804

The blocks will be inserted with a scale that takes into account the values of the current topographic scale.

If the **Create new** option is selected instead of selecting an existing block in the list, then after starting import, the block editor will open to create a point marker (conventional sign) block. The default is a circle. In the block editor, edit the marker, save the block, and exit the editor to complete the import.

When choosing to import a **block** from the list of those existing in the drawing, the selection of such attributes as **Name, Elevation, Code** is irrelevant – they will not be created additionally. They are grayed out and blocked.

Block

Text style

Main block g5\_117

Name

Elevation

Code

Create polyline  Closed

You can mark which attributes will be displayed in the geopoint description on the drawing: geopoint number (name), elevation (Z-coordinate) and code (point description).

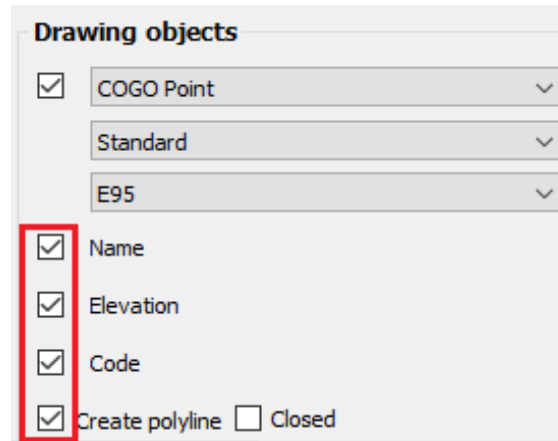

You can automatically create a polyline connecting all imported points. For example, if these are points of a road or a building.



To place points and titles, you can assign individual layers and colors. Titles can also be assigned with a font.

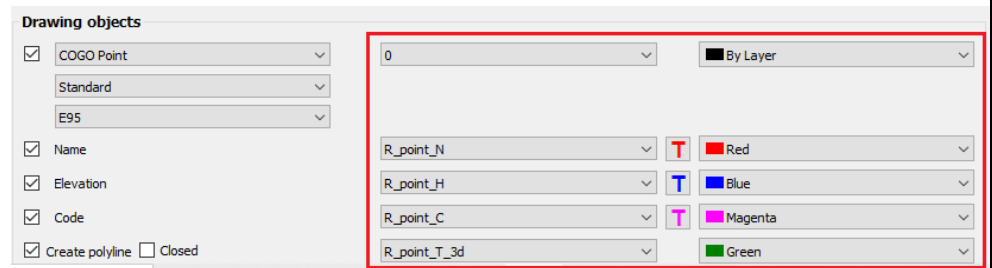

Labels can be assigned to a font.

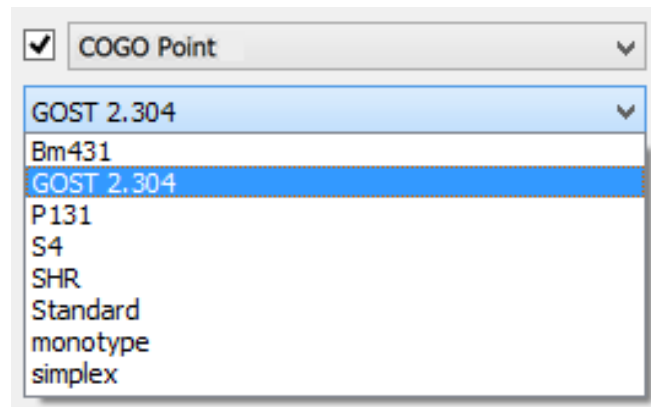

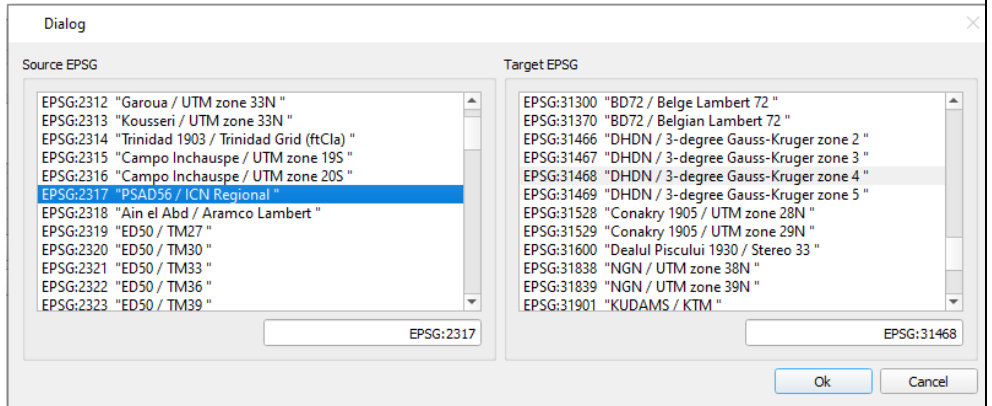
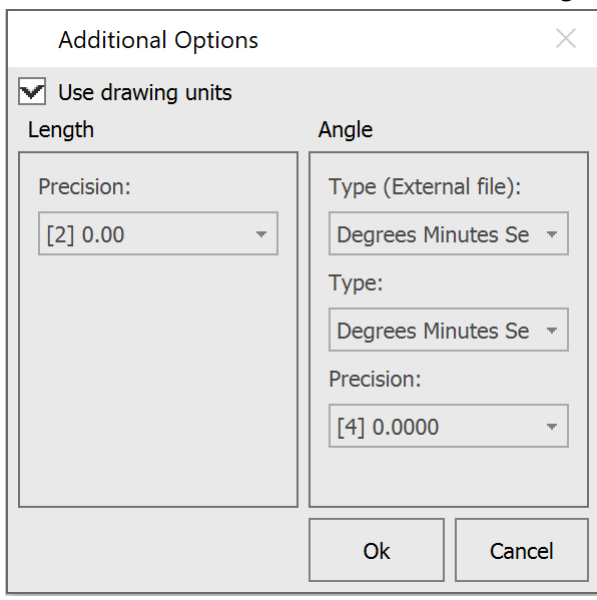
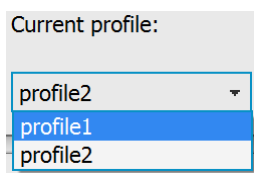

<p><b>Recalculate by EPSG</b></p>	<p> <input type="radio"/> UCS   <input type="radio"/> WCS   <input checked="" type="radio"/> EPSG Transformation ... </p> <p>Select in what coordinate system to import geodata: World or Custom ones or <a href="#">recalculate by EPSG codes</a>:</p> 
<p><b>Additional Options</b></p>	<p>The <b>Additional Options</b> button opens the window where you can change the settings for the units (UNITS) with which geopoints should be imported. By default, the current drawing units are used. The <b>Type (External file)</b> setting allows the user to set the data format in the external file. The data is converted into a format that is more convenient to edit and transferred to the drawing.</p> 
<p><b>Current profile</b></p>	<p>Allows you to save all the settings made in the dialog to a profile for further use.</p> <p>Current profile:</p> 

When Importing geopoints, standard styles are created.

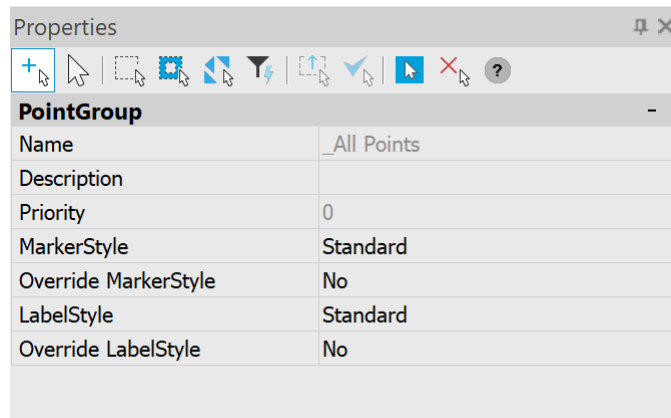

You can change the standard style by starting editing it from the [Drawing Explorer](#).

**NOTE** Files larger than 10000 lines are not supported. To be able to work with the data, split the file into smaller parts.

## Exporting Geopoints

-  Ribbon: **Topoplan – Import/Export** >  **Export Geopoints**
-  Menu: **Topoplan – Import/Export** >  **Export Geopoints**
-  Toolbar: **Import/Export** >  **Export Geopoints**
-  Command line: **NG\_EXPORT\_POINTS**

The **Export Geopoints** command allows you to save such objects as geopoints, blocks, simple points in TXT, CSV, SDR exchange formats, with the possibility to search for the text closest to the points and create labels in the drawing. When exporting geopoints to an external file, it is possible to save the label rotation value or other custom attributes. It is possible to select the file encoding.

Export

**▼ File**

Save As: File path: Extension: txt Encoding: windows-1251

**▼ Separator**

. dot   
  , comma   
  \t tabulation   
  ; semicolon   
  space  
 Other ;;   
 Decimal separator: . dot   
 New line char: \n

**▼ Selected objects**

COGO Point (17)   
 Create labels   
 Name: Increment   
 Elevation: By point   
 Code: By point  
 Block (712)   
 Create labels   
 Name: Increment   
 Elevation: By point   
 Code: By point

**▼ Data**

	Name	X (East)	Y (North)	Z	Code
1	COGO Points				
2	1	2226556.59	497612.46	0.00	
3	2	2226562.94	497597.03	0.00	

**▼ UDP classification**    **▼ Filters**

+  -   
  +  -

**▼ Result**

```

1 2226556.59 497612.46 0.00
2 2226562.94 497597.03 0.00
3 2226564.31 497600.90 0.00
4 2226565.69 497604.76 0.00
5 2226569.66 497612.90 0.00
6 2226568.75 497613.67 0.00
  
```

Current profile: Default     +  -    Ok Cancel Additional Options

**Options:**

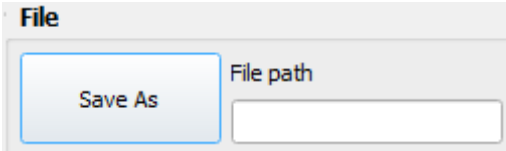
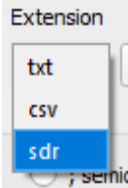
<p><b>Save as</b></p>	<p>Specify the storage location and name of the exported file.</p> 
<p><b>Extension</b></p>	<p>Geodata export format: CSV, SDR (Sokkia), TXT.</p> 

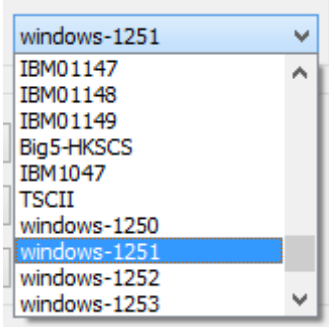
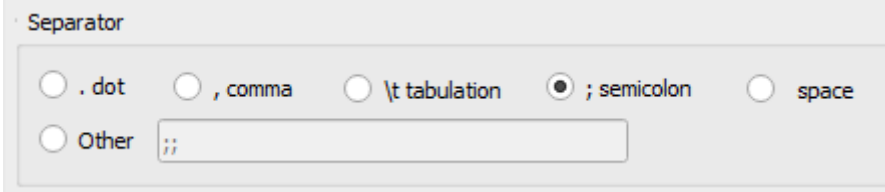
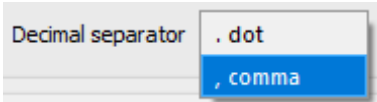
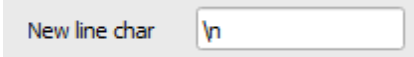
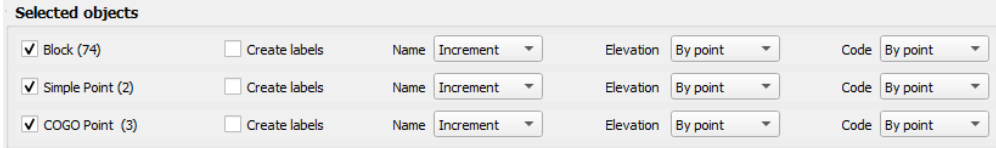
<p><b>Encoding</b></p>	<p>Encoding of the exported text file.</p> 
<p><b>Separator</b></p>	<p>Specifies a character that separates data in a text file.</p>  <p>For each export format (<b>Extension</b> list), its own separators are available. You can choose both predefined separators (dot, comma, semicolon, tab character, space), and set any other (<b>Other</b>). As a result, the data of the <b>Point data</b> table separated by the specified character will be exported to a file. The result can be previewed in the <b>Result</b> field.</p>
<p><b>Decimal separator</b></p>	<p>Specifies the decimal separator between the integer and fractional parts of numbers.</p> 
<p><b>New line character</b></p>	<p>Allows you to override the newline character.</p>  <p>The default character is \n.</p>
<p><b>Selected objects</b></p>	<p>The section defines what types of drawing objects should be exported as geodata to an external file. And also whether label descriptions should be exported and from which objects.</p>  <p>You can export geodata simultaneously from all or selectively from the following types of objects:</p> <ul style="list-style-type: none"> <li>• Common objects of the <b>Simple Point</b> type with label descriptions in the form of ordinary text objects;</li> <li>• <b>Block</b> insertions with single-line attributes as label descriptions (for example, conventional signs inserted into the drawing as blocks from the <b>Conventional signs</b> bar);</li> <li>• Objects of <b>COGO Point</b> type with a label.</li> </ul>

You can specify whether to generate labels for data from each object type, and where to get the values of each label description.

Values for the **Name** label can be taken from the increment, attributes of the point itself, or from the text object nearest to the point:

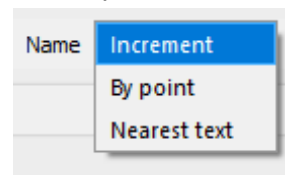

If you select **By point**, you will need to specify from which point attribute the information should be taken. The list will show the existing attributes of the geopoint or block:

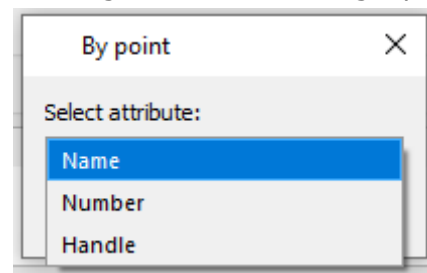

If you select **Nearest text**, you will need to specify the maximum distance from the point to the text object, at which this text will still be considered the label of this point:

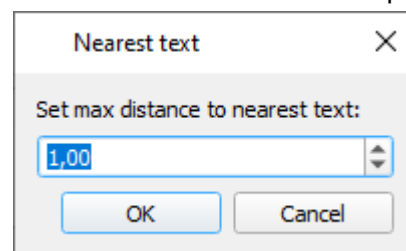

Values for **Elevation** (Z-coordinate) and **Code** labels can be taken from the attributes of the point itself or from the text object nearest to the point:

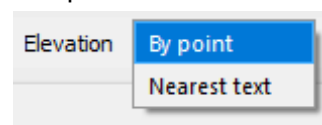

### Points data

The table performs typing and editing of data obtained from point objects: point coordinates by X, Y and Z, numbers, descriptions of points. The column heading displays the data type. In case of incorrect initial data typing, you can drag one header to another, thereby mutually changing them.

▼ Data

	Name	X (East)	Y (North)	Z	Code
1	COGO Points				
2	1	2226556.59	497612.46	0.00	

▼ Data

	Name	X (East)	Y (North)	Code	Z
1	COGO Points				
2	1	2226556.59	497612.46	0.00	

You can delete selected cells, rows, or columns. Multiple selection is supported using **SHIFT** and **CTRL**. Rows or columns are selected by clicking on the heading. Before manually deleting data, it is recommended to filter them out using filters.

You can also edit the data after double-clicking on a cell.

▼ Data

	Name	X (East)	Y (North)
1	COGO Points		
2	1	2226556.59	497612.46
3	2	222656	

▼ UDP classification

+ -

▼ Result

1	2226556.59	497612.46	0.00	0.00
2	222656			

- Undo Ctrl+Z
- Redo Ctrl+Y
- Cut Ctrl+X
- Copy Ctrl+C
- Paste Ctrl+V
- Delete
- Select All Ctrl+A

**UPD (User Defined Properties) classification**

You can add custom properties to points with the  button. You should specify the type (integer, float, or string) and name.



A new empty column appears in the **Points Data** table with the name of the custom parameter. Drag this column heading onto the heading of the column you want it to match.

**Filters**

You can exclude data from export not only manually by deleting cells from the **Points data** table, but also by setting filters. For example, you can exclude from export all points with heights below 52 (**Z** column) and with a number greater than 350 (**Name** column).





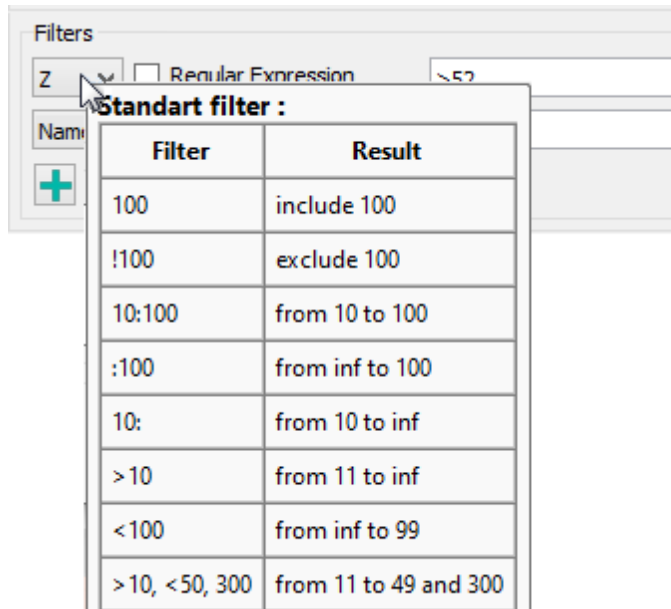

After adding the filter with the  button, in the drop-down list, select the column by which all exported data will be filtered. Then set the value that the column data should satisfy. The rest of the lines will be excluded from the export. Hovering over the filter displays a tooltip with sample values.

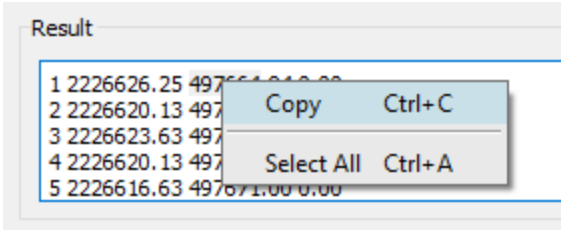
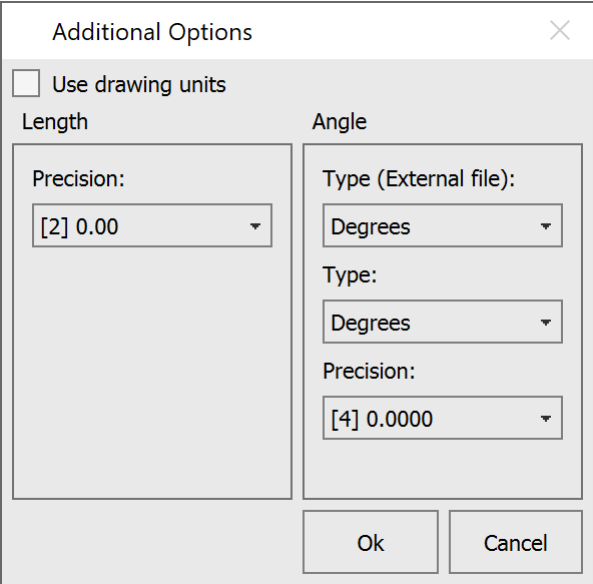
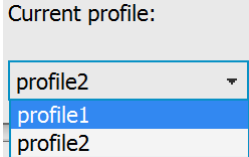

It is recommended to set filters only after correct data typing in the **Points data** section.

<p><b>Result</b></p>	<p>Viewing the preliminary result of exporting geodata to a text file. Selected data can be copied.</p> 
<p><b>Additional options</b></p>	<p>The <b>Additional Options</b> button opens the window where you can change settings for the units (UNITS) with which geoints should be exported. By default, the current drawing units are used.</p> 
<p><b>Current profile</b></p>	<p>Allows you to save all the settings made in the dialog to a profile for later use.</p> 

## Import from LandXML

-  Ribbon: **Topoplan – Import/Export** >  **Import from LandXML**
-  Menu: **Topoplan – Import/Export** >  **Import from LandXML**
-  Toolbar: **Import/Export** >  **Import from LandXML**
-  Command line: **NG\_IMPORT\_LANDXML**

The command allows you to import a surface from the LandXML format. As a result, a **Mesh** object will be created in a drawing

LandXML is a popular format for exchanging data with other applications. In nanoCAD it is possible to import and export surface data using LandXML version 1.2 format.

After running the command, a standard file selection dialog box will open. Choose XML file and click **OK**. The command options will be displayed on the **Properties** toolbar:



The command options are specified on the **Properties** toolbar.

**Options:**

<b>Xml units</b>	Displays the units in which XML file was saved.
<b>Dwg units</b>	Displays the units in which it is required to display objects from XML file. If drawing units are meters, and the <b>Dwg units</b> option is set in meters, then objects from a file will be imported without scaling (1:1).
<b>Geodetic CS</b>	As in the geodetic coordinate systems (as opposed to the generally accepted rectangular Cartesian) the X axis is directed to the north, and the Y axis – to the East, for the correct import of object from XML file, it is required to specify the parameter value – <b>Yes</b> . If you specify <b>No</b> , X and Y coordinates will reverse places during import.

When you import a surface, a “TIN Surface” layer is created.

## Export to LandXML

 Ribbon: **Topoplan – Import/Export** >  **Export to LandXML**

 Menu: **Ground – Import/Export** >  **Export to LandXML**

 Toolbar: **Import/Export** >  **Export to LandXML**

 Command line: **NG\_EXPORT\_LANDXML**

The command exports a surface (**Mesh** object) and geopoints to the LandXML format for use in other applications.

After running the command, select a surface to be exported to the XML file. The command options will be displayed on the **Properties** toolbar:

The command options are specified on the **Properties** toolbar.

**Options:**

<b>Xml units</b>	Displays the units in which XML file will be saved.
<b>Geodetic CS</b>	As in the geodetic coordinate systems (as opposed to the generally accepted rectangular Cartesian) the X axis is directed to the north, and the Y axis – to the East, for the correct export of object to XML file, it is required to specify the parameter value – <b>Yes</b> . If you specify <b>No</b> , X and Y coordinates will reverse places during import.
<b>Surface</b>	Enables/disables export of surface (SubMesh object).
<b>Geopoints</b>	Enables/disables export of geopoints. When exporting, the belonging of points to a group remains.

## Import from GIS

 Ribbon: **Topoplan – Import/Export** >  **Import from GIS**

 Menu: **Ground – Import/Export >  Import from GIS**

 Toolbar: **Import/Export >  Import from GIS**

 Command line: **GEOIMPORT**

The command imports polylines and point objects from \*.SHP and \*.MIF files.

After running the command, it opens the dialog box in which you need to select an existing import template from the list or to create a new one.

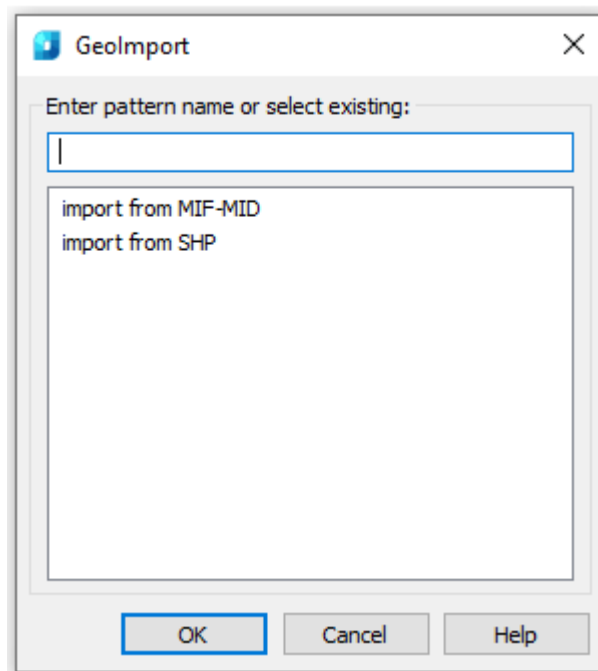

Each import template can contain one or more nested object class templates.

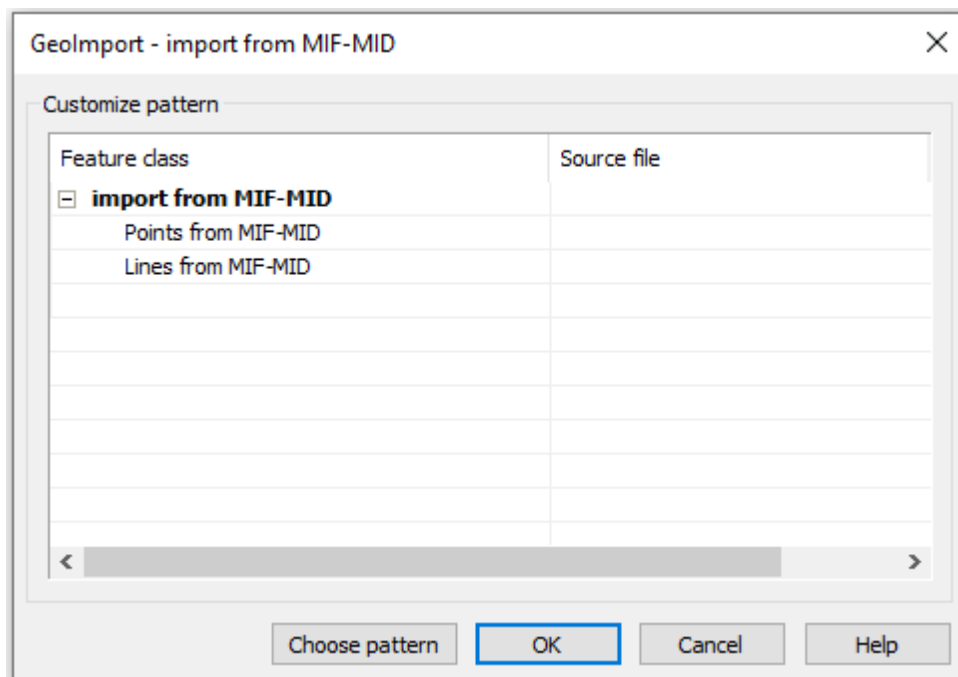

First, create a new object class template, and then specify the corresponding output file. Template names are displayed in the left column of the dialog (**Feature class**), and output files – in the right one (**Source file**).

To create a class template, expand the class collection, click the empty field of the last stream in the left column and enter the name of a new template:

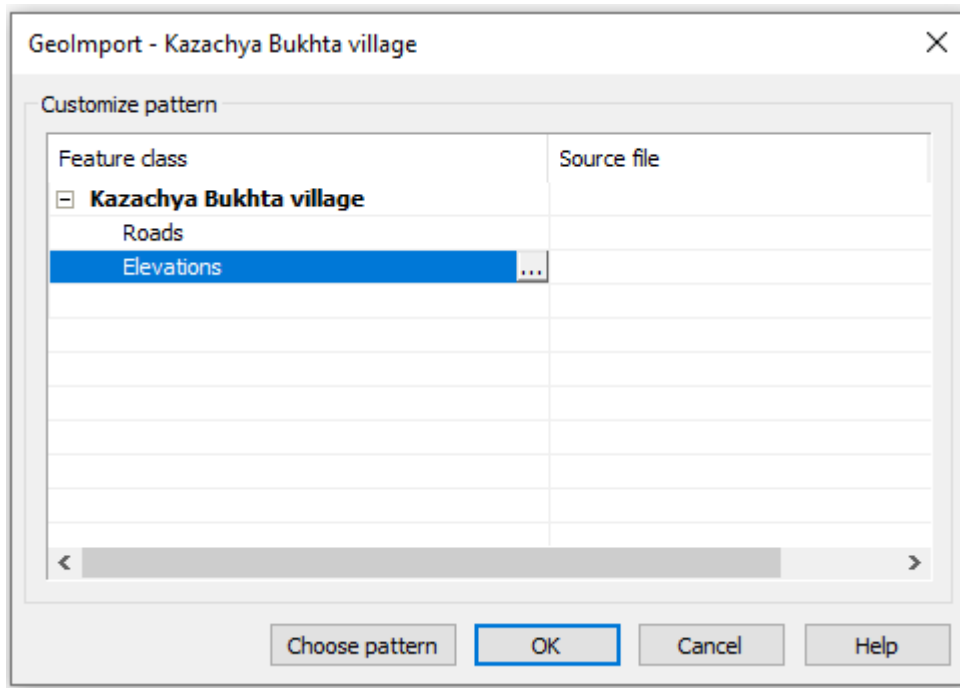

**NOTE:** A name should not contain the following characters: \ / : \* ? “ ” < > |

The context menu is available:

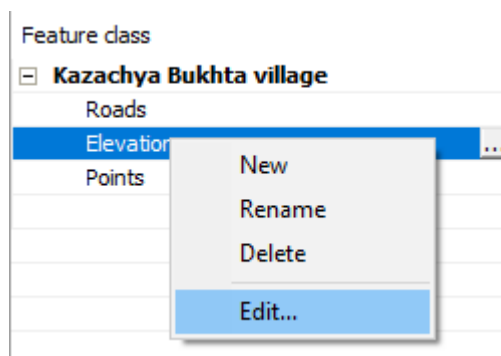

Click  button to the right of a template name to edit it or select **Edit** in the context menu

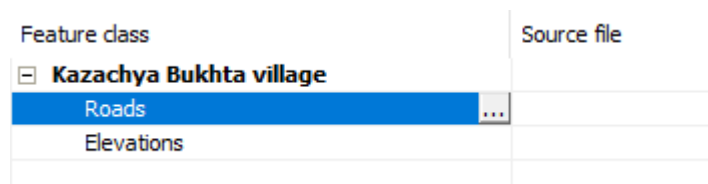

A class template is a set of rules for data conversion. It determines which objects will be imported and sets the correspondence between the parameters of the external format objects and nanoCAD objects.

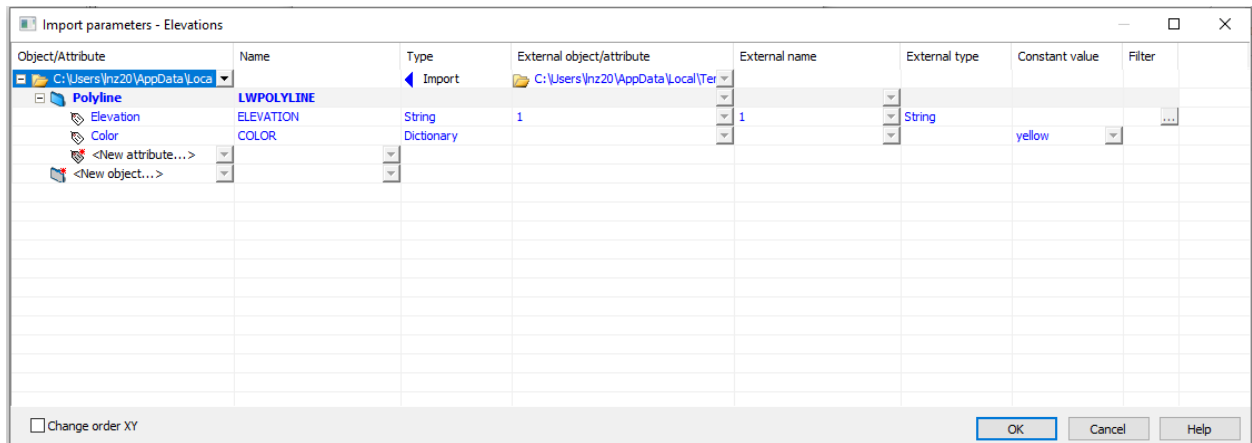
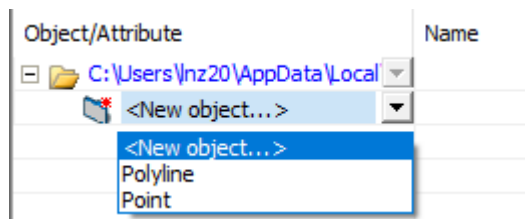

Table columns can be hidden using the context menu called by the right click.

### Sequence of configuring a template:

1. In the **Object/Attribute** column, select a type of objects to be imported from an external file.



Only one type of objects should be specified in the template – if two or more are specified, they will not be taken into account.

It specifies the type of objects that should be imported into the drawing from a file:

- **Polyline** – export of linear objects from the external file with converting them to a polyline object.
- **Point** – export of point objects from the external file.

2. If you need to import all objects of this type, and do not need to specify additional import conditions, then click OK to close the dialog box. Otherwise, click on the “+” sign to the left of the added object type, and specify the parameters to which the import condition will be applied.

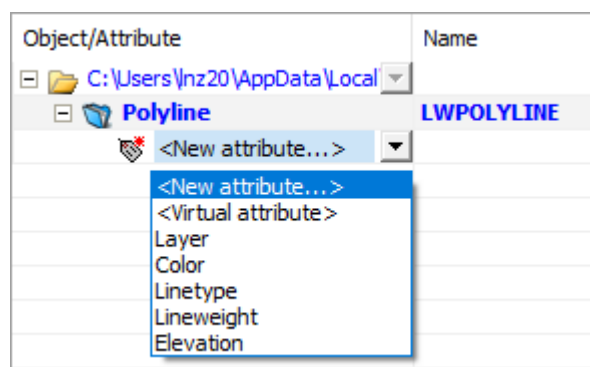

3. If the value of this parameter should not inherit the value of the imported object parameter, but should simply receive a previously known value (for example, **Roads** layer existing in the document or **color red**), then in the **Constant value** column you should select the required value from the drop-down list.

External type	Constant value
	yellow
	ByBlock
	ByBlock
	ByLayer
	Continuous
	GOST2.303 3
	GOST2.303 5
	GOST2.303 4
	GOST2.303 6
	GOST2.303 8
	GOST2.303 9

This list presents the standard values and values contained in the current nanoCAD document. To set a non-standard value, assign it to the object of the current document, then you can select it in the drop-down list.

4. If the parameter value should inherit the parameter value of the imported object, then click in the first cell of the **External object/attribute** column and select the **Scan file** in the menu that opens

External object/attribute	External name
C:\Users\Inz20\AppData\Local\Te	
C:\Users\Inz20\AppData\Local\Temp\Source.xml	
<Load from file...>	
<Scan from file...>	

In the dialog box that opens, specify the file with mif (shp) extension, from which the data should be imported.

As a result, information about all types of imported objects and their parameters will be taken from the specified file.

If you have a ready-made type template in the.xml format, then instead of scanning geo-file, you can select **Load from file** and specify xml.

5. In the **External object/attribute** column, select from the drop-down list the external parameter, the value of which should be inherited by the internal parameter in the **Object/Attribute** column.
6. You can use filters to restrict the import of objects by certain values of their parameters. Thus, you can import objects only with a certain parameter value or a range of values, objects with empty/non-empty parameter value. For import operations, restrictions are imposed on the parameters of external objects from the **External object/attribute** column.

To set a filter, double-click a cell in the **Filter** column. This will open a window, the content of which depends on the type of value of the external object parameter (in the **External value** column).

A type of dialog for numeric values (Integer, Real, etc.):

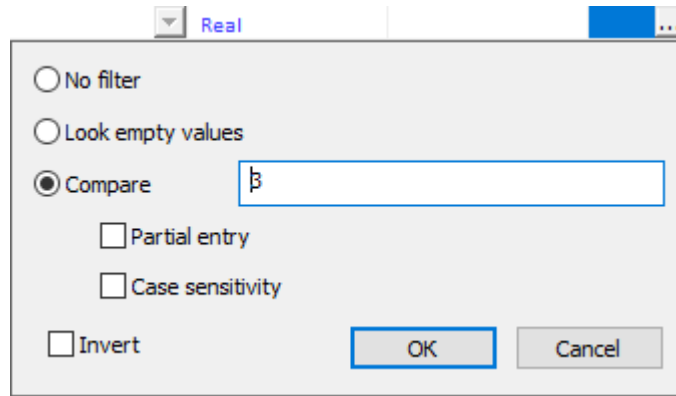

**Look empty values** – only objects with a missing parameter value (selected in the **External object/attribute** column) will be imported.

**Compare** – enter a value to which the comparison operator from the **Task** Drop-down list will be applied

**Task** – a logical operator. Together with the **Compare** field value, sets the filtering condition (the screenshot shows the condition=3).

**Invert** – a logical operator that inverts a given condition. It can be used only in case of **Search for empty values**. In other cases, it is ignored.

## Export to GIS

 Ribbon: **Topoplan – Import/Export** >  **Export to GIS**

 Menu: **Topoplan – Import/Export** >  **Export to GIS**

 Toolbar: **Import/Export** >  **Export to GIS**

 Command line: **GEOEXPORT**

The command exports polylines and point objects to \*.SHP and \*.MIF files.

After running the command, select the objects to be exported. In export templates the objects are filtered from the selection specified at this step. After selecting objects, a dialog for multiple export to geo-formats opens. In the dialog that opens, select an export template from the list or create a new one.

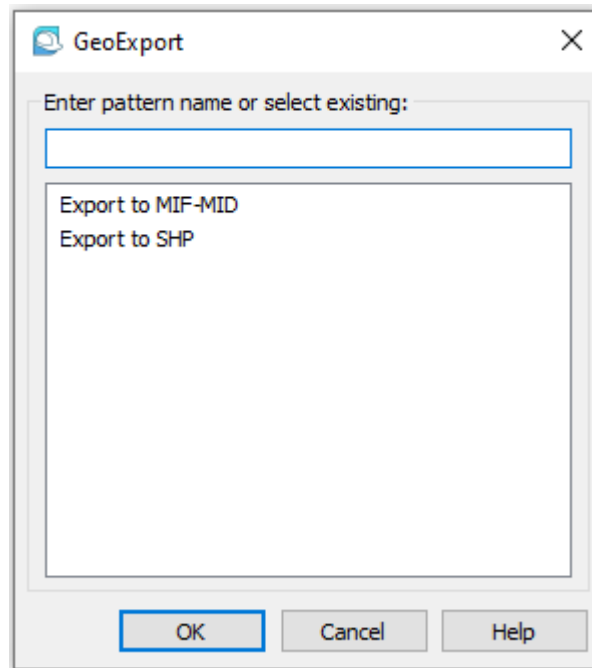

### *Creating and editing an export template*

Each export template can contain one or more nested templates of Feature classes (**Feature class** column), which are associated with the output external files of SHAPE or MID/MIF format, where the data will be exported (**Destination file** column).

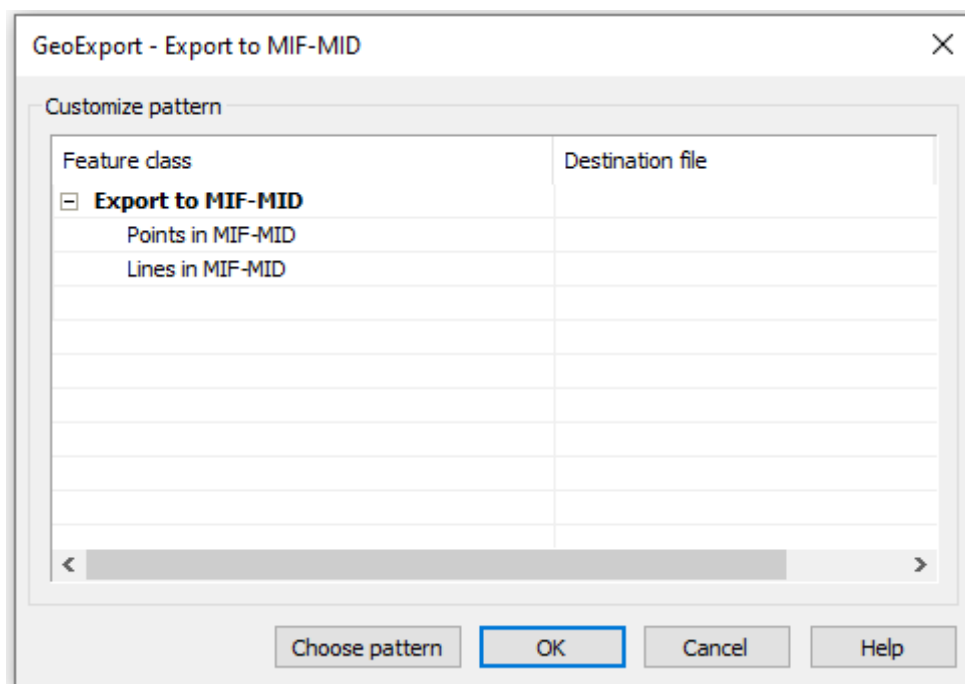

To create a class template, expand the export template and double-click an empty field in the **Feature class** column. In the text field, enter the name of the new template:

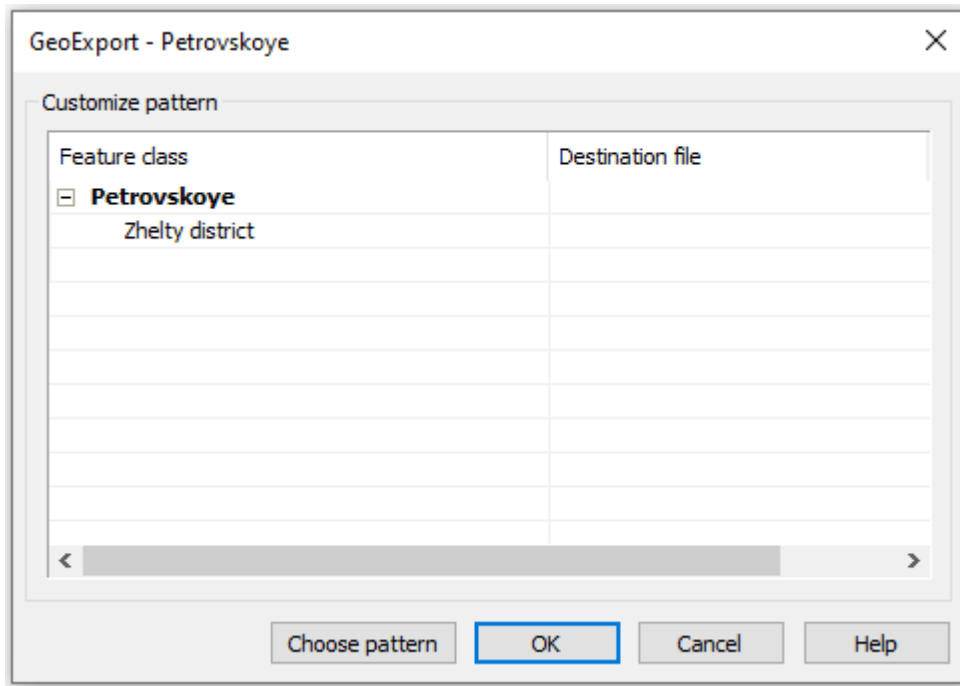

**NOTE:** The name should not contain the following characters: \ / : \* ? “ ” < > |

The same can be done using the context menu available in this dialog:

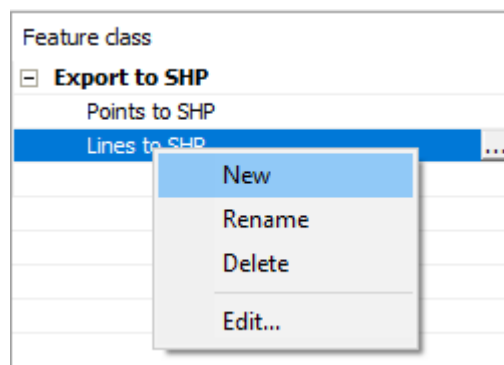

To edit the content of a class template, select its name in the **Feature class** column and click **...** button on the right or select **Edit** in the context menu.

This will open the template settings dialog. A class template is a set of rules for data conversion. It determines which objects will be exported and sets the correspondence between the parameters of nanoCAD objects and external format objects.

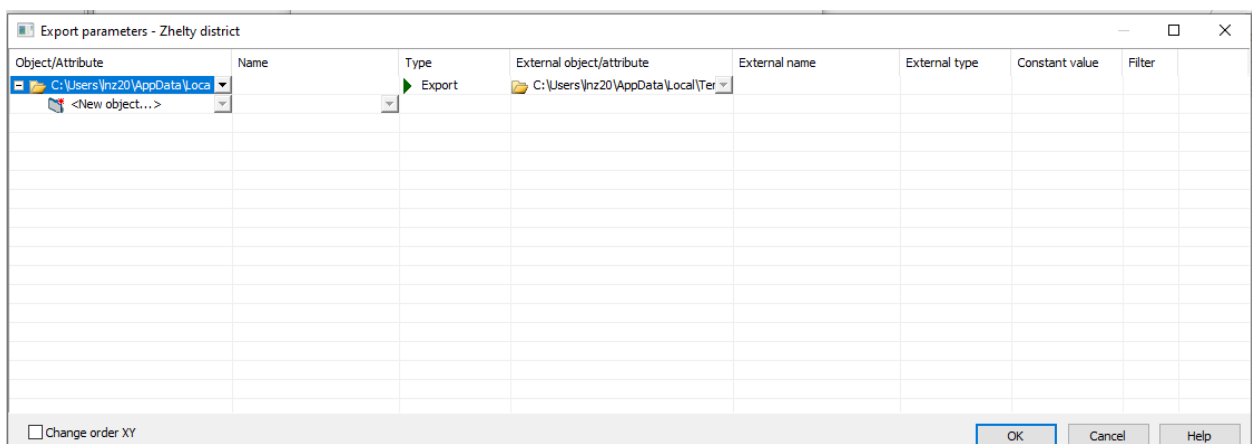

The **Change order XY** box is checked in the case, when the coordinates along the X axis and coordinates along the Y axis should be changed during export.



First, you should specify the type of objects to be exported: **Polyline, 2dPolyline, Point**.

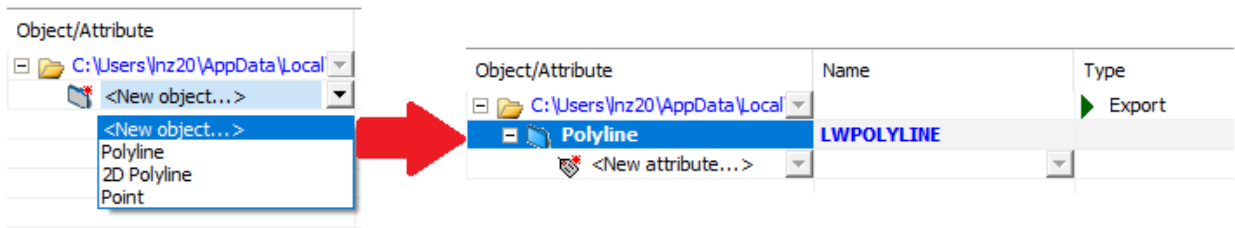

Usually, in the nanoCAD drawing, roads and buildings are represented by polylines:



Only one type of exported objects can be specified in each template. To export other types, create new templates.

**NOTE:** the objects will be exported not from all objects in the document, but from the selection that was made at the first command prompt, immediately after its start.

Below there is a table for converting types of objects when exporting to MID/MIF format:

<b>nanoCAD objects type</b>	<b>MID/MIF, SHP objects type</b>
<b>Polyline</b> not closed (property <b>Closed = No</b> )	<b>Polyline</b>
<b>Polyline</b> closed (property <b>Closed = Yes</b> )	<b>Polygon (Region)</b>
<b>Point</b>	<b>Point</b>

### *Filtering the exported selection of objects using attributes*

If you need to export not all the objects of the specified type, but a certain selection, then you should specify the attribute value by which the selection is carried out. For example, to export all buildings, as a rule, it is enough to set the **Polyline** object with the **Closed** "real" attribute value.

Click the **<New attribute...>** field and select the **Closed** attribute in the drop-down list

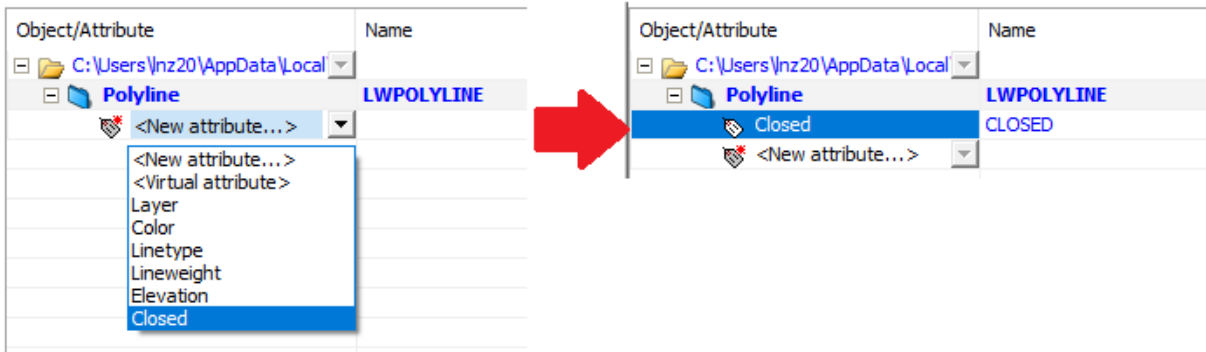

The attribute value is set by clicking  button in the **Filter** column.

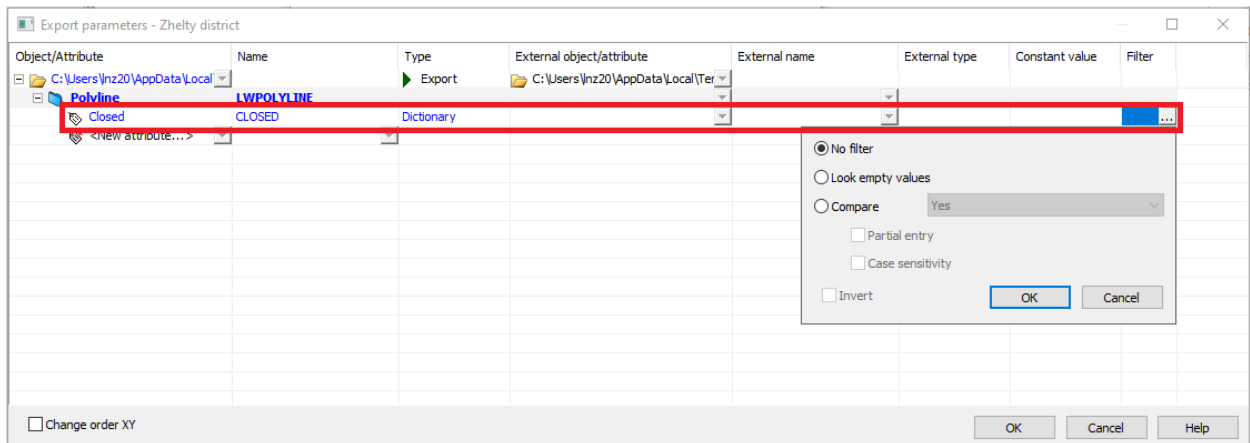

In the dialog that opens, select **Compare**, and in the drop-down list select the attribute value – **Yes**.

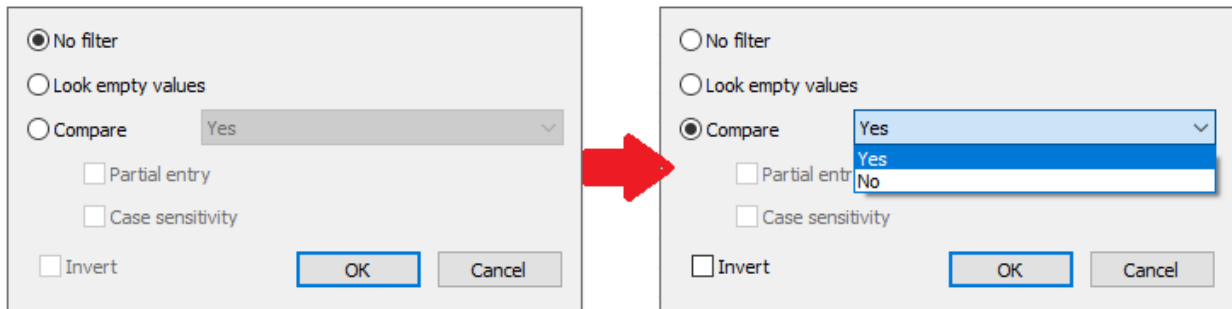

**Filtering options:**

<p><b>No filter</b></p>	<p>Filtering by attribute value is not required. I.e., the attribute is not used to create the required selection of objects (and only for export of values to an external file).</p> <p>When the <b>No filter</b> item is set, the  icon in the <b>Filter</b> field of the <b>Export settings</b> dialog disappears.</p>
<p><b>Search for empty values</b></p>	<p>Objects with an unassigned value of this attribute will be selected.</p>
<p><b>Compare</b></p>	<p>Allows you to set a specific value for an attribute.</p> <p>A list of fixed values is available for most of the attributes.</p> <p>For the <b>Level</b> attribute you should enter the value yourself.</p>
<p><b>Partial matching</b></p>	<p>Available for the <b>Level</b> attribute that does not have a fixed list of values.</p>

<b>Match case</b>	Available for the <b>Level</b> attribute that does not have a fixed list of values.
<b>Invert</b>	Inverts the selection by the given attribute: the selection will include all objects with the attribute value NOT meeting the specified criteria.

Now in the **Filter** column opposite to the **Closed** attribute, the  icon will appear, which means that a value for this attribute has been set and is used as a filter during export.

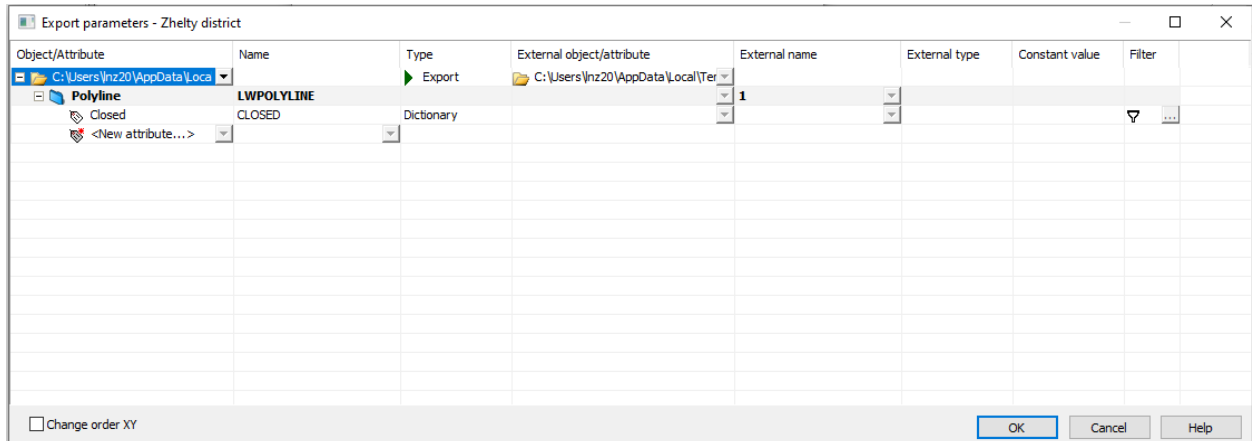

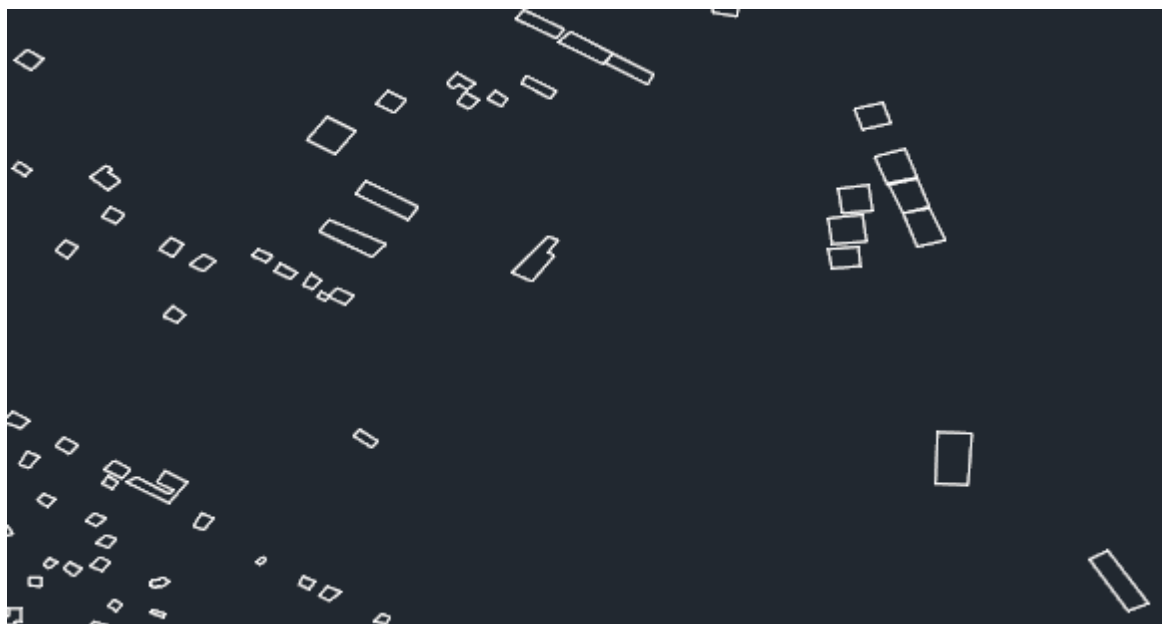

If you use the resulting template for export, then the output file will contain all closed polylines (buildings) of the same color:

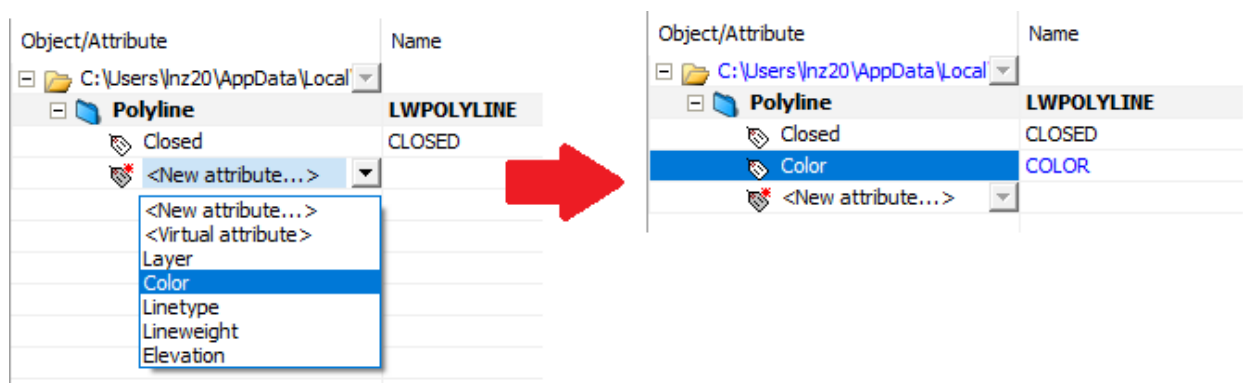

To export only yellow buildings with preserving polylines color in the output file, it is required to complicate the template a little.

Let's set one more attribute – **Color**.



The attribute value should be specified in its filter. To do this, click  button in the **Filter** column next to the corresponding attribute.

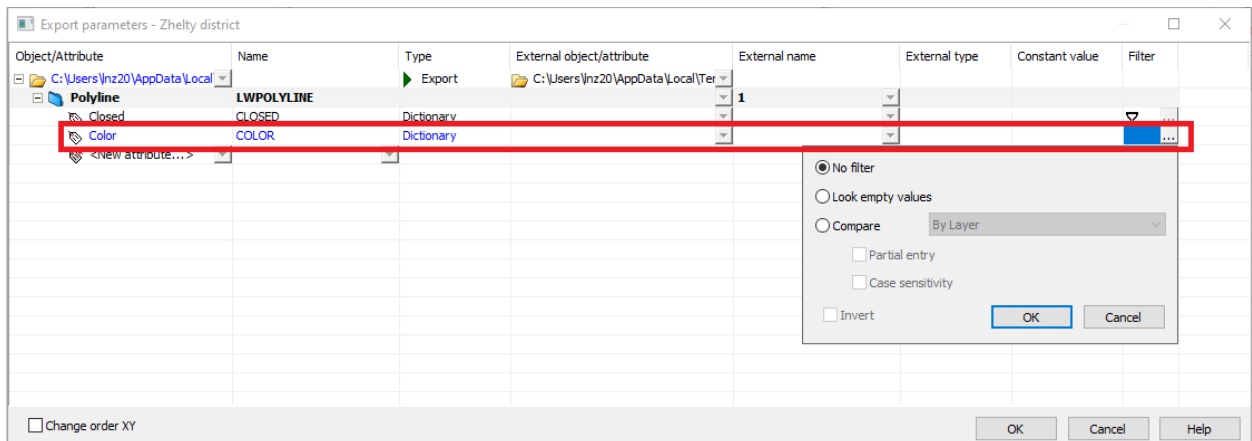

In the window that opens, select the desired value. To set the yellow color, select the **Compare** item and select **Yellow** from the drop-down list of available values.

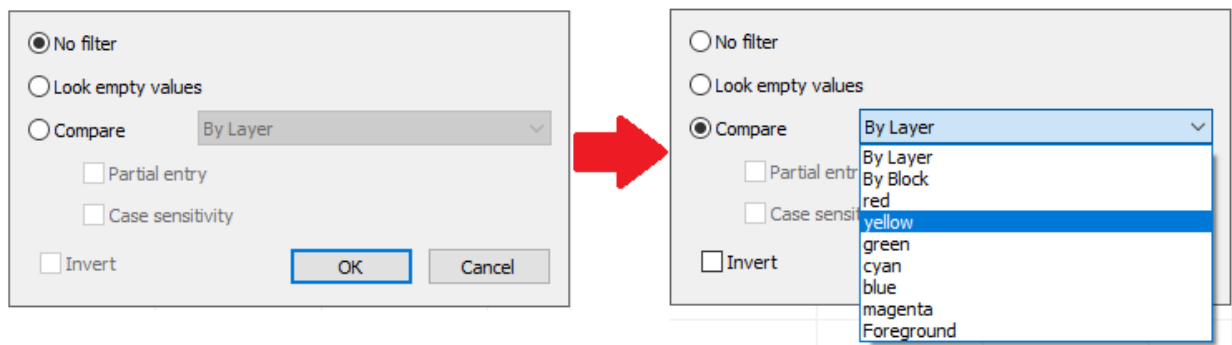

Now all closed yellow polylines will be exported.

### Exporting attribute values to the external format

To preserve the color during export, the **Color** attribute should be matched to the desired external format attribute.

You can get a completed list of external format attributes by loading semantic data from XML file of by scanning an existing MIF or SHP file. To do this, select **<Load from file...>** or **<Scan from file...>** in the External object/attribute field from the drop-down list

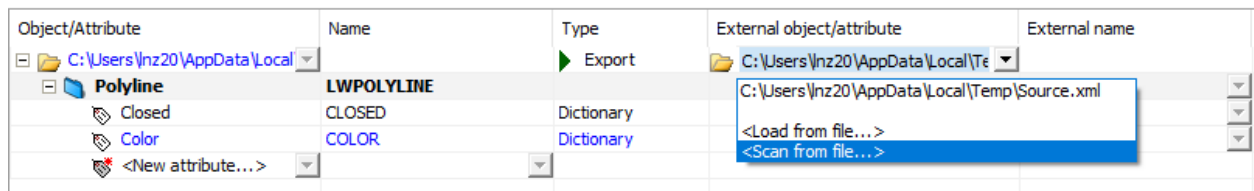

In the window that appears, specify the file from which you want to get semantic information.

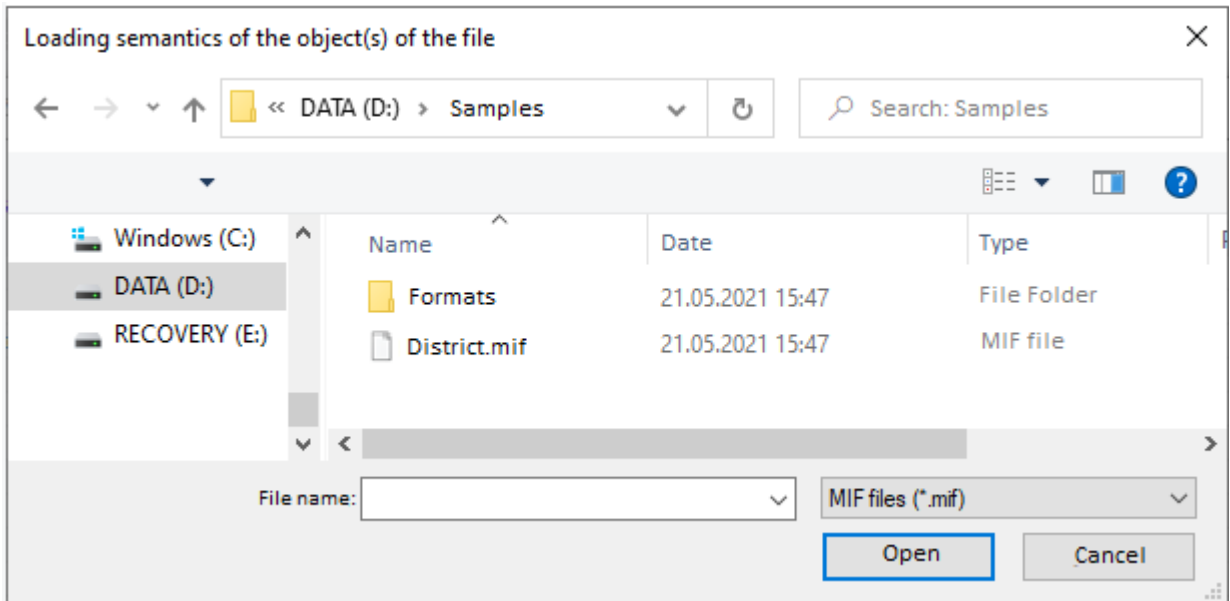

In case of scanning files, a new xml file is created with an identical name containing semantic information,

Now in the **External object/attribute** column you can specify an external attribute that should inherit the value of the internal **Color** attribute when exporting objects.

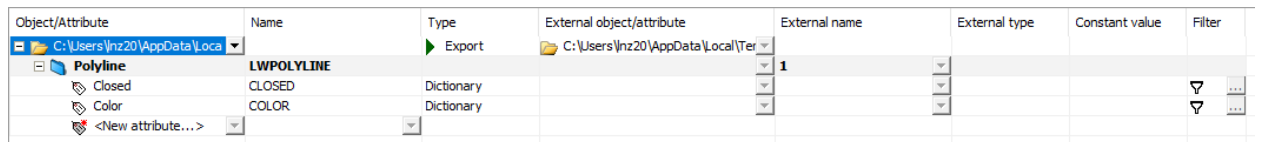
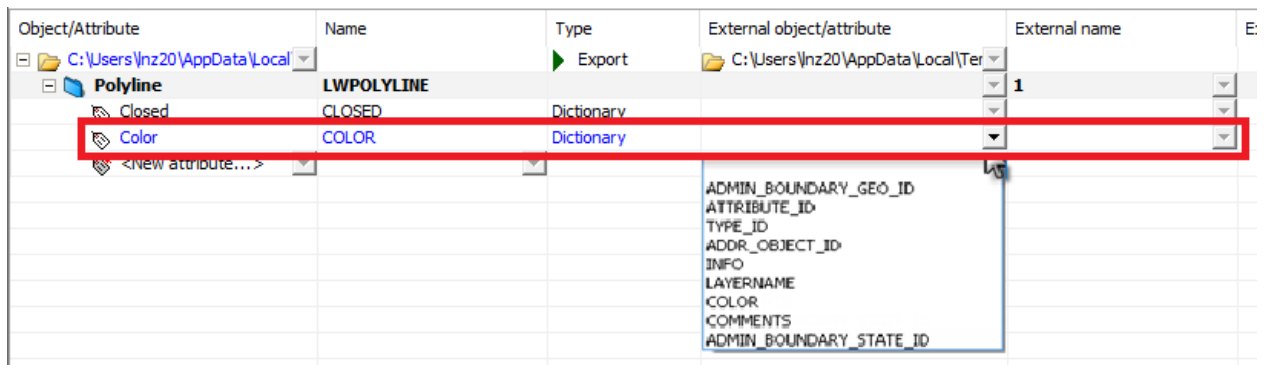

If objects are sorted into layers, it is most convenient to use the **Layer** attributes to filter objects.

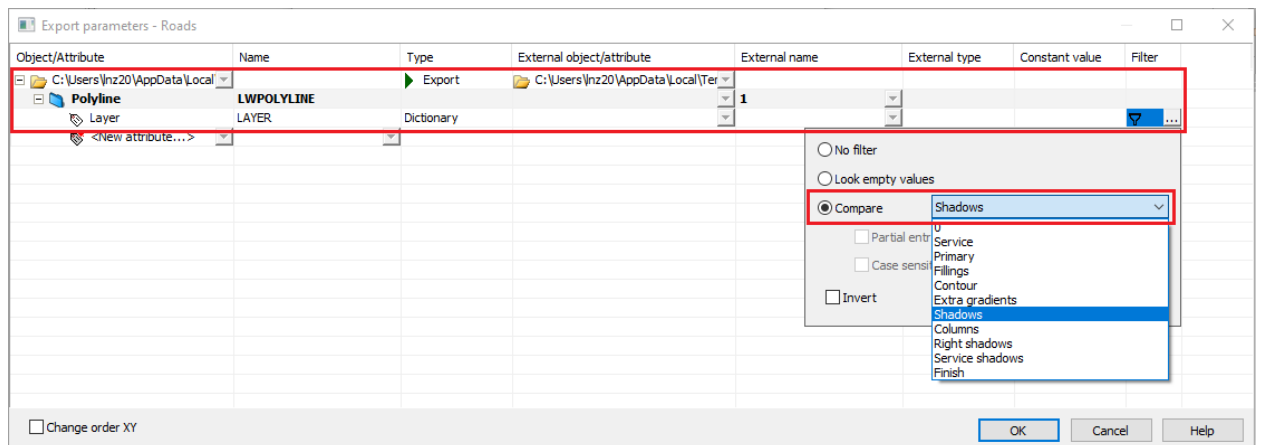

A **Virtual attribute** is used in a case, when during export for the external files objects you need to set the value of the attribute that is missing in nanoCAD objects.

### Geodata objects

After configuring all templates, in the geodata export dialog, to the right of a name of each template, specify an output file of MIF format, to which the data should be exported.

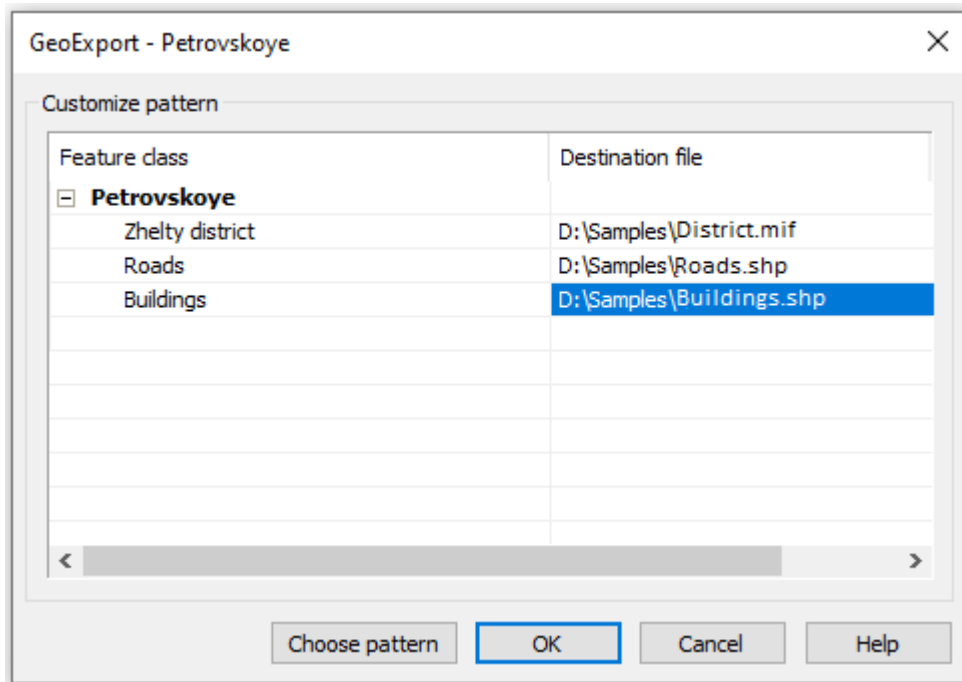

As a result, we created “template-output file” pairs, indicating by what rules and in which file the data should be exported.

After creating all “template-output file” pairs, click **OK** to export the data.

The export will be carried out for all templates to which the output file was assigned. Templates without an output file will be ignored.

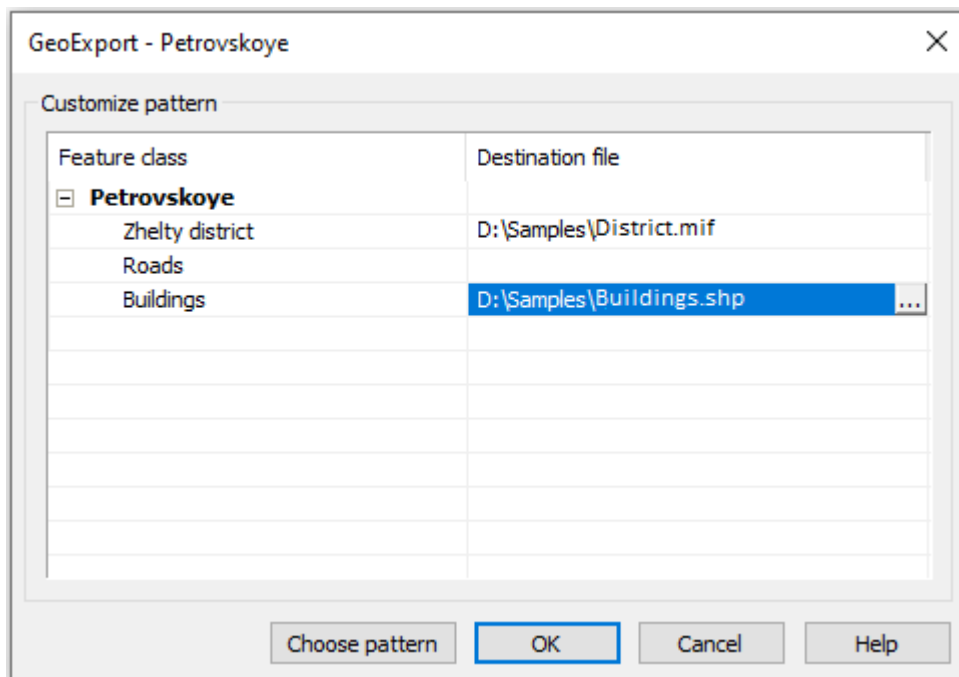

**NOTE:** In order to avoid data loss, do not indicate the same output file for different templates.

## Import of KML/KMZ files

-  Ribbon: **Topoplan – Import/Export >  KML/KMZ import**
-  Menu: **Topoplan – Import/Export >  KML/KMZ import**
-  Toolbar: **Import/Export >  KML/KMZ import**
-  Command line: **KMLIMPORT**

The command imports from KML/KMZ (Keyhole Markup Language) format with a possibility to recalculate data from/to various topographic and geodetic coordinate systems using EPSG codes.

### To import KML/KMZ:

Run the command.

In the file selection dialog that opens, select a file to import.

The **EPSG Transformations** dialog box appears.

In the right part of the dialog box, mark the objects to be imported from the file.

In the EPSG text fields, enter the number of the source and target coordinate systems according to the EPSG classification, focusing on the list provided. Click **Apply**.

Information on the selected target geocoordinate system will appear in the **Transformation info** section. To confirm the transformation, click **OK**.

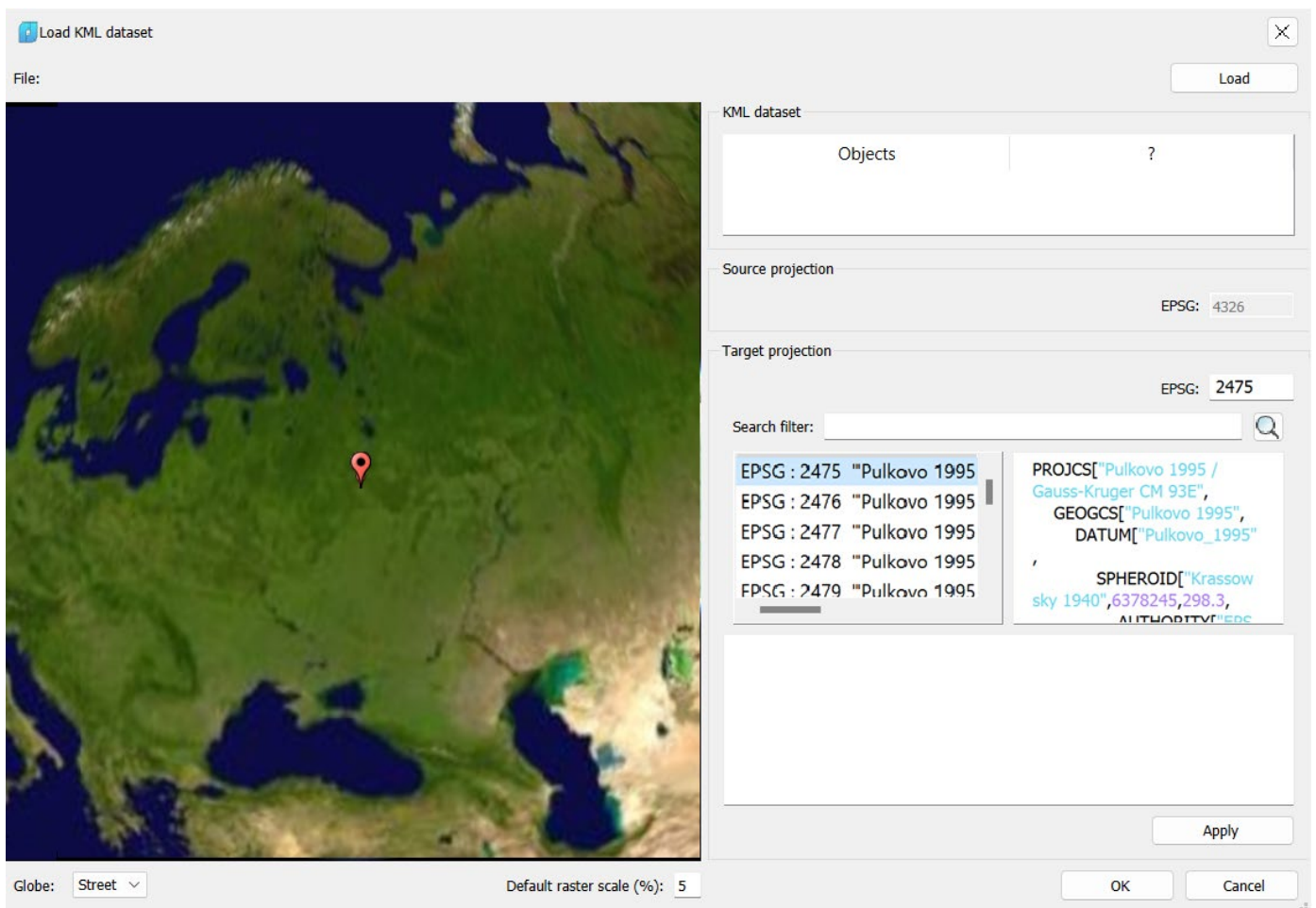

Labels without image will be imported as points. The point will be displayed with an icon (raster). A point is added to the bottom left corner of the icon.

Hyperlink	
Transparency	ByLayer
<b>3D Visualization</b> -	
Material	ByLayer
Visual style	Het
<b>Image Adjust</b> -	
Brightness	50
Contrast	50
Fade	0
<b>Geometry</b> -	
Position X	6832308.4801
Position Y	-1775390.1337
Position Z	0
Rotation	0
Width	32
Height	32
Scale width	7.874



## Design of Layouts

The possibility to split a drawing into prepared sheets for subsequent printing has been implemented. The **Create frames** command allows you to place view frames of future layouts on the drawing. The **Create Layouts by Frames** command creates layouts based on frames with the desired design and scale.

### Creating Frames

-  Ribbon: **Topoplan – Design of Layouts** >  **Create frames**
-  Menu: **Topoplan – Design of Layouts** >  **Create frames**
-  Command line: **CreateViewFrame**

The command allows you to create frames in the model space for the subsequent formation of designed layouts. Each frame is a viewport of such a layout.



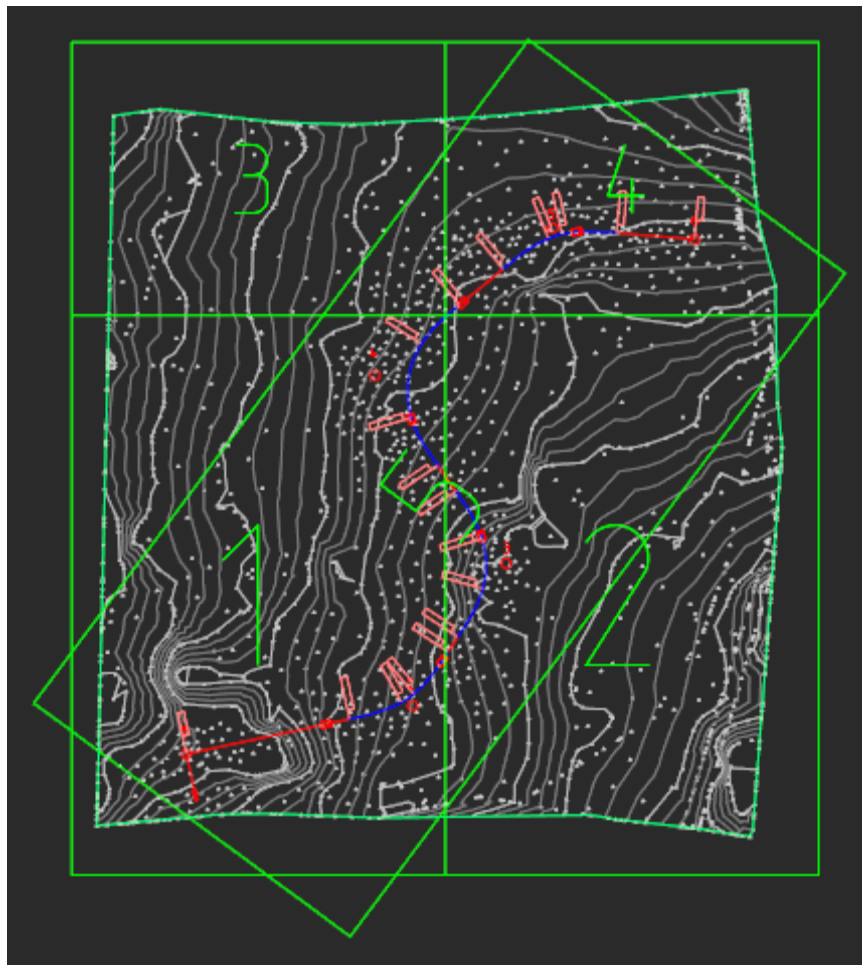

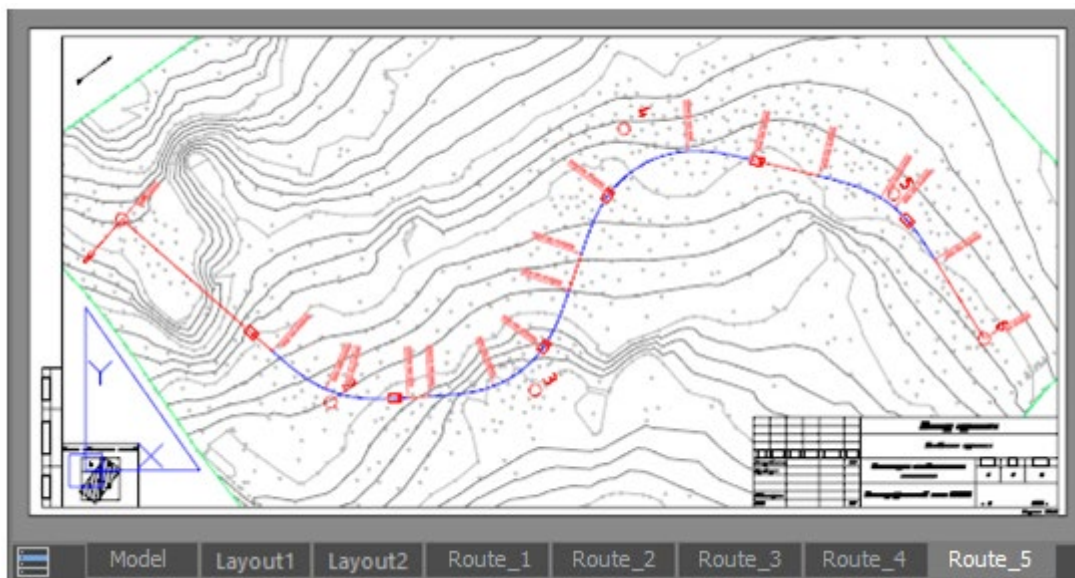

Each frame carries information about the template, format and scale of the layout. The design of the future layout will be taken from the template in accordance with the format.

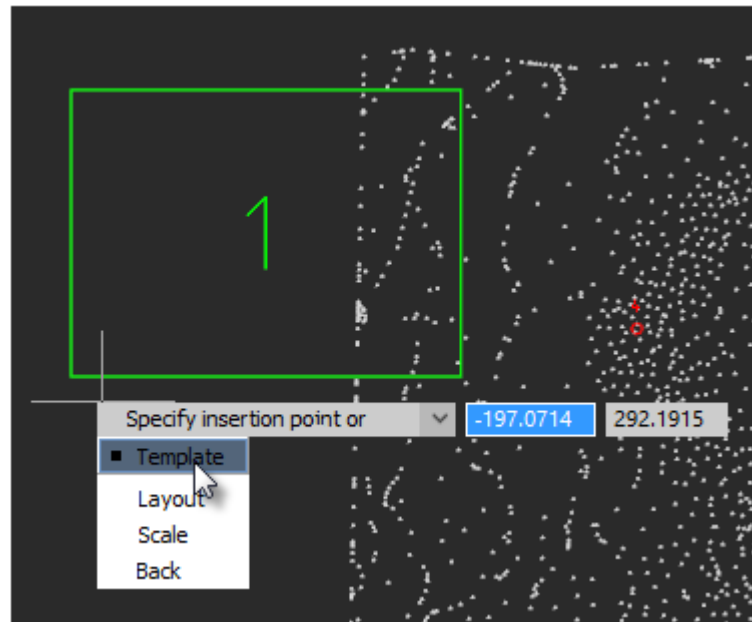

After the **Create frames** command starts, you can configure the options of future layout for the frame:



**Template** – a template file containing a list of available formats with frame design. You can specify a template for formats according to standards or for a topographic tablet.

Name	Date modified	Type	Size
 Topo_GOST_Layouts.dwt	01.12.2021 12:29	Platform Template	548 KB
 Topo_Square_Layouts.dwt	03.12.2021 23:24	Platform Template	322 KB

After selecting a template, specify the layout size for the inserted frame.

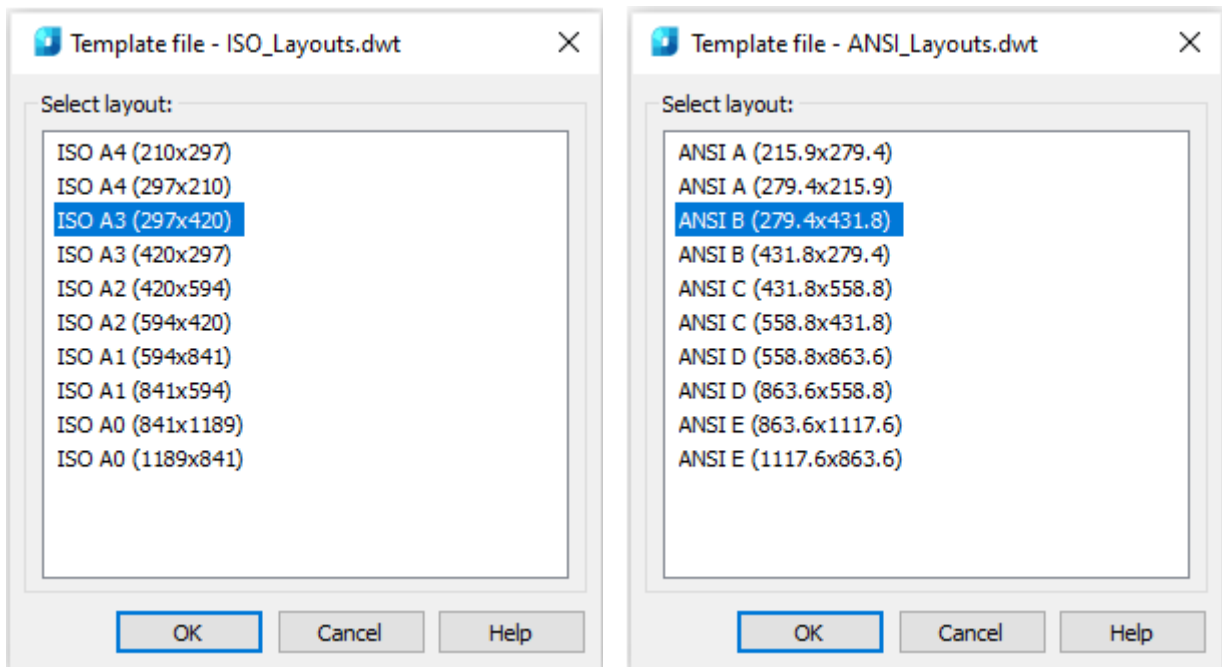

**Layout** – the option allows you to assign a layout format without reassigning the template.

**Scale** – selection of the topographic scale. By default, the scale of the created sheet is set according to the current TOPOSCALE.

The frame profile corresponds to the bounds of the layout's viewport that will be created from them with the **Create Layouts by Frames** command. In case of selecting horizontal layout formats, this is clearly visible.

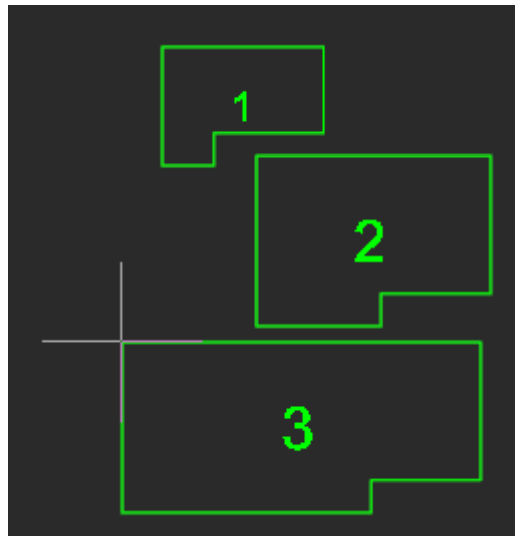

A visible cutout is a place for a stamp, which in small horizontal formats can occupy a significant part of the layout.



After setting all the parameters, specify the position of the view frame in the drawing. In this case, you can use the nanoCAD precise positioning tools to snap to axial, auxiliary lines, mesh, points, or existing view frames. You can rotate frames and use other standard mechanisms for placing objects in the drawing workspace.

When inserting a frame, you can change its anchor point. By default, the anchor point is located in the lower left corner of the frame. Changing the anchor point of the frame is convenient in case of designing routes, as they can go in any direction. This is also true for tablets, where numbering usually goes from left to right and from top to bottom. But, when trying to insert the second row, it is already inconvenient to use the anchor point in the bottom left.

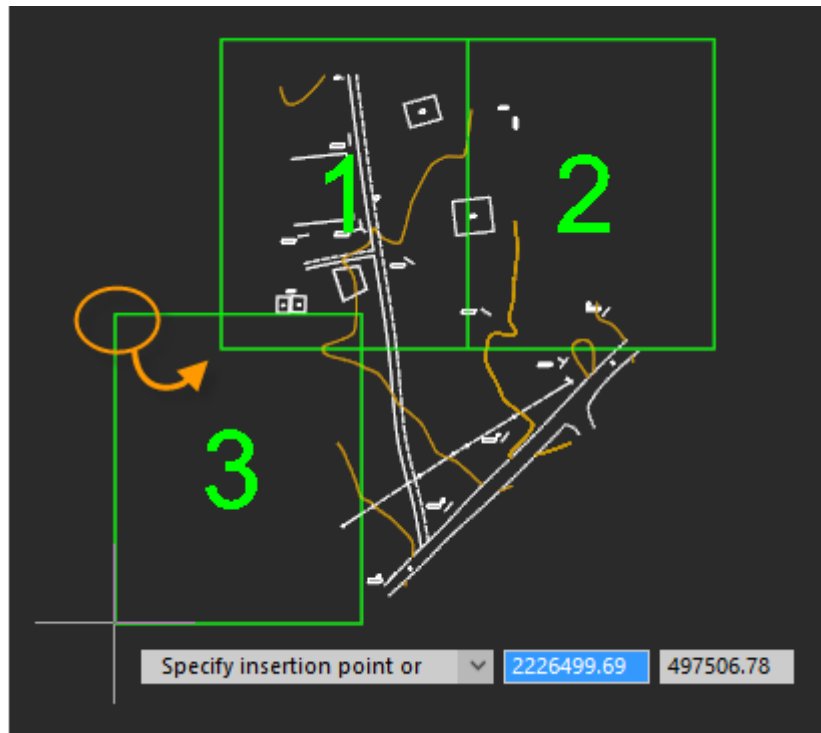

For cycle change of the anchor point, just press the **SPACE** key or select the **Anchor point** keyword. The anchor point can be set to any vertex of the frame



All created frames are placed on the **View Frames** layer.

## Creating Layouts by Frames

 Ribbon: **Topoplan –Design of Layouts** >  **Creating Layouts by Frames**

 <Menu: **Topoplan – Design of Layouts** >  **Creating Layouts by Frames**

 Command line: **CreateViewFrameLayout**

The command creates layouts for designing a drawing according to previously created frames. Each frame has its own layout with the same design, format and scale that were specified when creating the frame by the **Create frames** command.

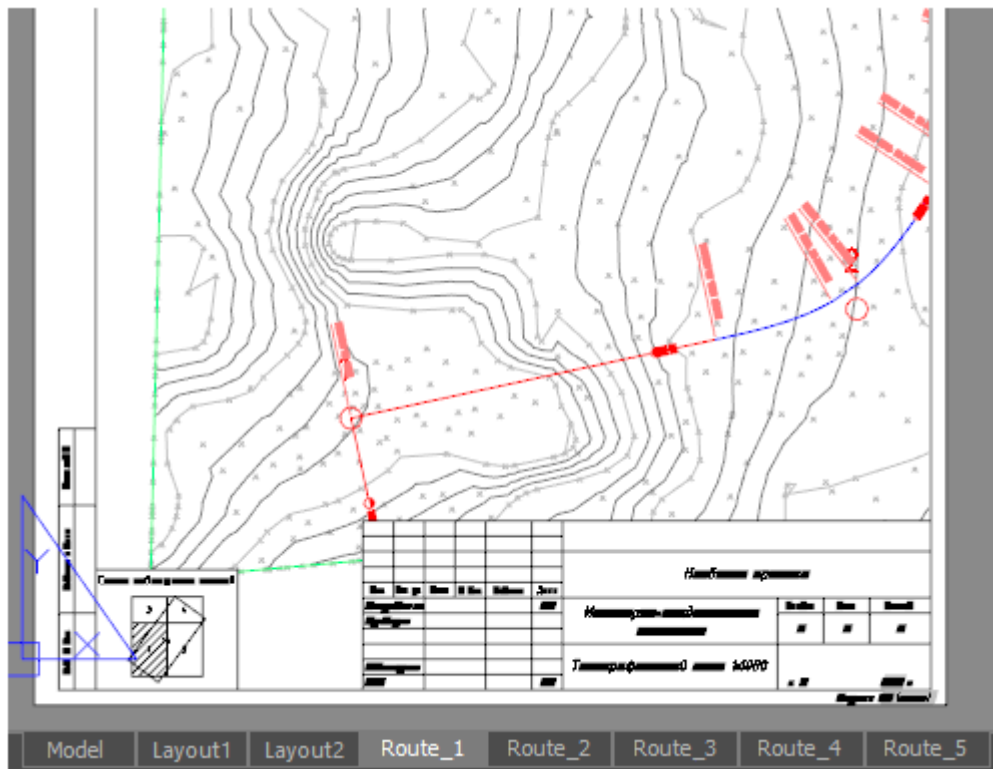

After running the command, you should enter the name of the group of layouts, which will be used as a prefix in the layout names created by the split box.

The layout's frame and stamps are a dynamic block with parameters and attributes that can be edited in the **Properties** bar or using grips.

Depending on the frame template, the sheet will be designed in accordance with standards or in the form of a topographic tablet.

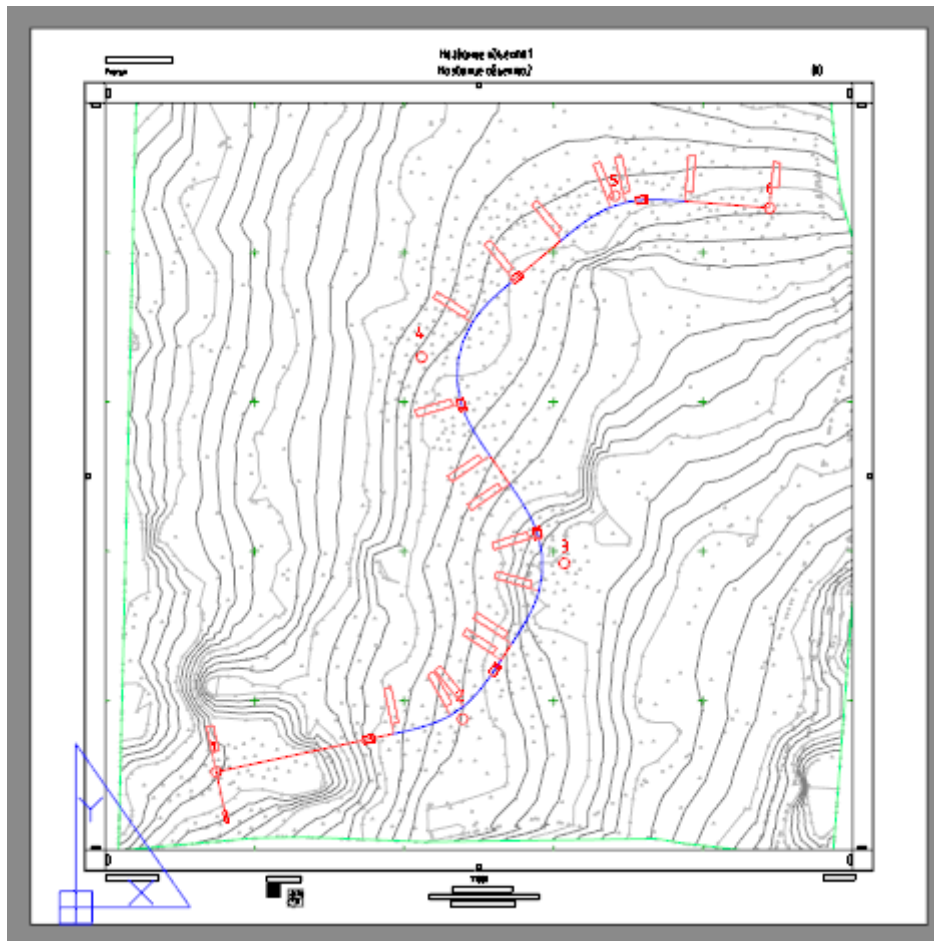

For tablets, a scheme of the survey area is created, and for standard sheet formats, a scheme for combining sheets.

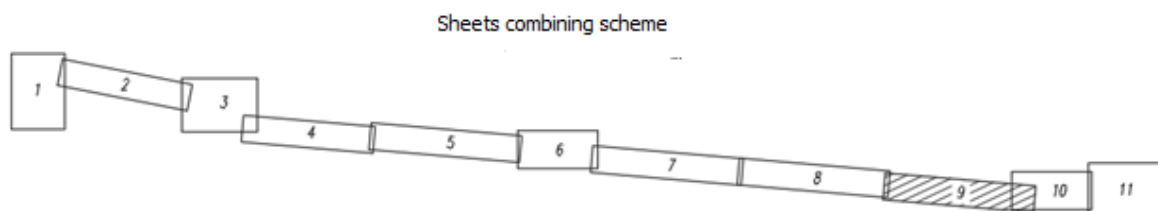

## Hiding Frames

- 
Ribbon: **Topoplan – Design of Layouts** >  **Hide frames**
- 
Menu: **Topoplan – Design of Layouts** >  **Hide frames**
- 
Command line: **HIDEVIEWFRAMES**

Mode for hiding frames created by **Create frames** command. Turns off the display of all created frames in the model space. Repeated execution of the command returns the display of frames.

## Deleting Frames

-  Ribbon: **Topoplan – Design of Layouts** >  **Delete frames**
-  Menu: **Topoplan – Design of Layouts** >  **Delete frames**
-  Command line: **DELETEVIEWFRAMES**

Deletes all frames created by the **Create frames** command.

## Measurement Archive

The work with measurements can be divided into 2 stages: collection of a measurement files archive and formation of a project underlays collection from this archive.

An archive of measurement files contains raw or preprocessed data, while a set of prepared underlays should be groups of geopoints ready for use in projects.

### Filling the archive of measurement files

Measurement files are stored in the **Geofiles** folder. The path to the folder is defined in the **Standard directories** section of the **Options** dialog.

To add a file to the archive, the  **Add measurements** command is used, with the help of which the required file on the disk is specified, if necessary, a new name is given to it, after which it is copied to the measurement archive.

If you need not only to save a raw file, but to carry out a full import at this stage, so as not to return to setting parameters later, then you should use the  **Save to the measurement archive** command. You need to configure the parameters in it, after which the result in the form of a DWG file is placed in the archive.

The measurement archive is displayed in the file explorer in **Geofiles** folder. By expanding it, you can view all archive measurement files.

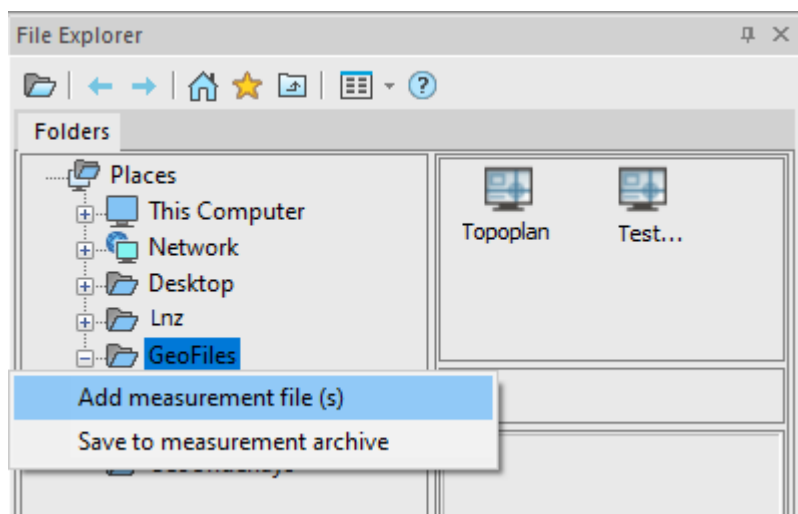



### Creating selections and forming a set of underlays

To work with points, it is necessary to form selections from the measurement archive.

Selections are formed by special commands in the form of separate DWG files, which are subsequently placed as external references in working drawings. Thus, the same selection (underlay) can be inserted into several different working DWG files.

To form a selection:

1. Create a new underlay with the  [Insert a Geounderlay](#) command.
2. Import the required measurements into it from the archive using the  [Import measurements](#) command
3. Configure groups of points, forming them, if necessary, and setting their parameters (styles). Enable/disable the visibility of the desired groups.
4. Save the drawing to the collection of underlays as a separate named entity using the  [Save as geounderlay](#) command.

The underlay collection is a separate **Geofiles** folder. The path to the folder is defined in the **Standard directories** section of the **Options** dialog.

It is also visible in the File Explorer as the **Geofiles** folder. By expanding it, you can view all the underlay files.

## Adding Measurement File

 Ribbon: **Topoplan – Measurements Archive** >  **Add Measurements**

 Menu: **Topoplan – Measurements Archive** >  **Add Measurements**

 Command line: **GEOFILE\_ADD\_MEASUREMENT\_FILES**

Adding measurement files to the archive. The command moves the selected files (without opening) to the measurements archive.

The command can be launched from the ribbon, menu, command line, and context menu of the **Geofiles** folder in the **File Explorer** bar.

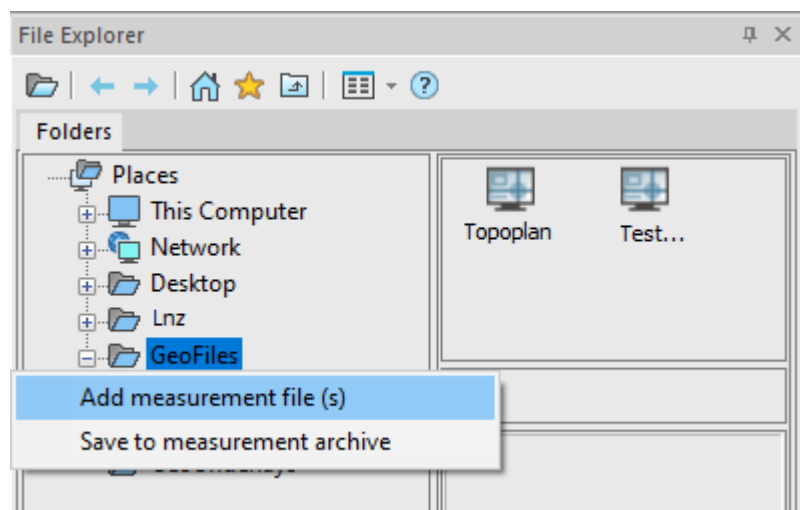



In the dialog that opens, select the measurement file to be added. Supported formats: DWG, SDR (Sokkia), CSV, XYZ, TXT.

## Import Measurements

 Ribbon: **Topoplan – Measurements Archive** >  **Import Measurements**

 Menu: **Topoplan – Measurements Archive** >  **Import Measurements**

 Command line: **GEOFILE\_IMPORT\_MEASUREMENTS**

Importing measurement files into a drawing.

If the command was launched from the context menu of a file selected in the **Geofiles** folder in the **CFile Explorer** bar, then the current drawing is immediately imported from the measurement file.

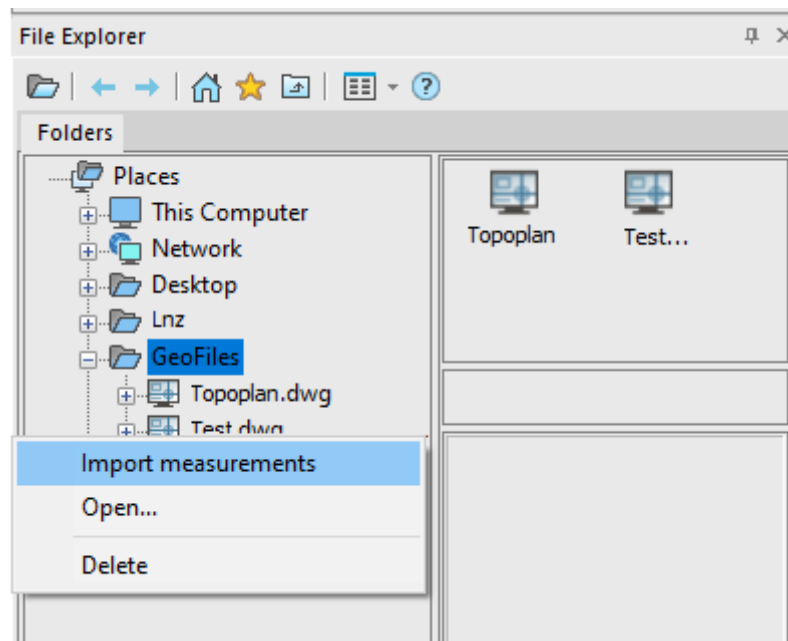

If the command was launched from the ribbon, menu or command line, then a file open dialog appears with the **Geofiles** folder open, where you should specify the measurement file to be imported.

The contents of the DWG files will simply be pasted into the current drawing. For files of other formats, the [Import geopoints](#) command will be launched.

## Save to Measurement Archive

 Ribbon: **Topoplan – Measurements Archive** >  **Save to Measurement Archive**

 Menu: **Topoplan – Measurements Archive** >  **Save to Measurement Archive**

 Command line: **GEOFILE\_SAVE**

Saving the current drawing to the measurements archive.

Specify the file name (the name of the current one is specified by default).

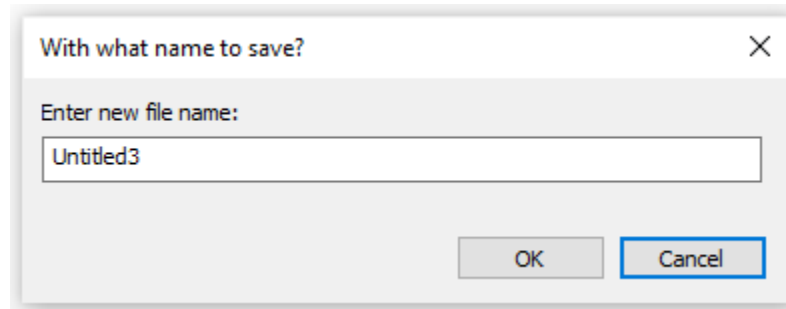

The file is saved to the **Geofiles** folder.

The path to the folder is determined in the **Standard directories** section of the **Options** dialog

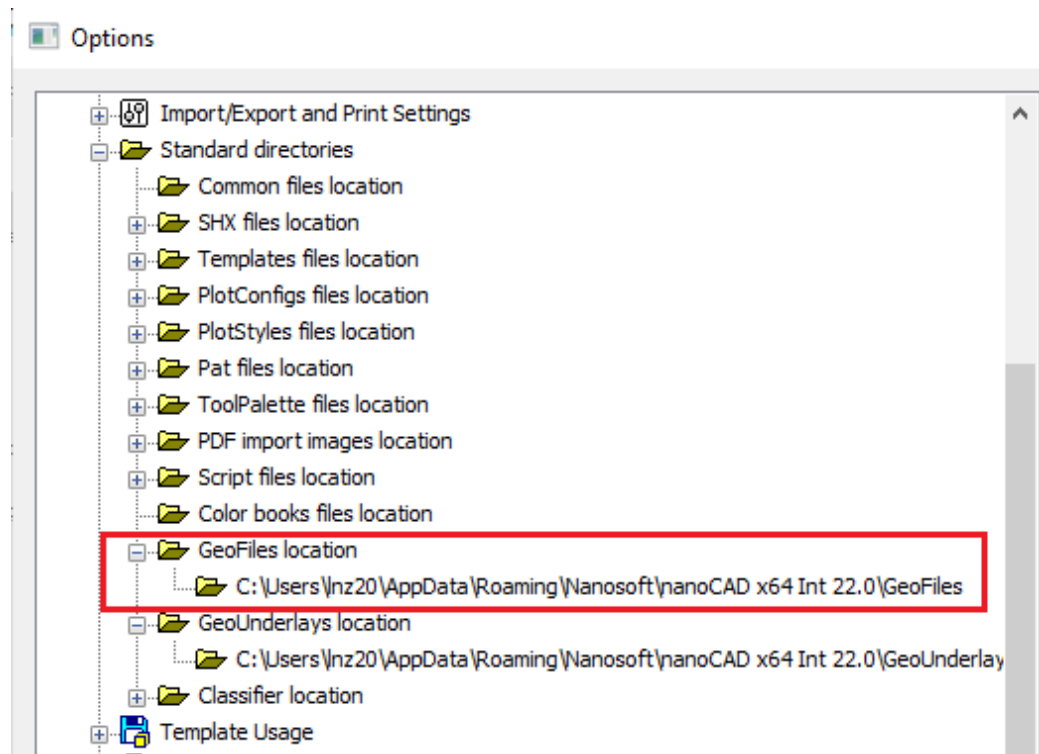

## Attach Geounderlay



Ribbon: **Topoplan – Measurements Archive** >  **Insert a Geounderlay**



Menu: **Topoplan – Measurements Archive** >  **Insert a Geounderlay**



Command line: **GEOUNDERLAY\_ATTACH**

Inserting a geounderlay (as an external reference) from the archive into the current drawing.

If the command was launched from the context menu of a file selected in the **Geounderlays** folder in the **File Explorer** bar, then the specified geounderlay is immediately inserted into the current drawing. You can insert a geounderlay into the current document as an external reference or insert its content.

If the command was launched from the ribbon, menu, or command line, then a file open dialog appears with the **Geounderlays** folder open, where you should specify the geounderlay file to insert.

## Save as Geounderlay



Ribbon: **Topoplan – Measurements Archive** >  **Save as Geounderlay**



Menu: **Topoplan – Measurements Archive** >  **Save as Geounderlay**



Command line: **GEUNDERLAY\_SAVE**

Saving a current file to the geounderlays archive.

Specify the file name (the name of the current one is specified by default).

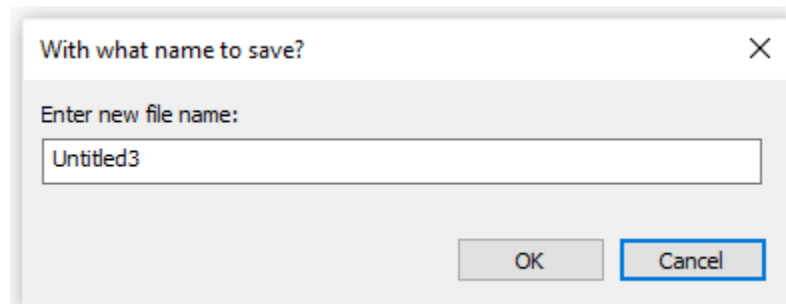

The file is saved to the **Geounderlays** folder.

The path to the folder is determined in the **Standard directories** section of the **Options** dialog.

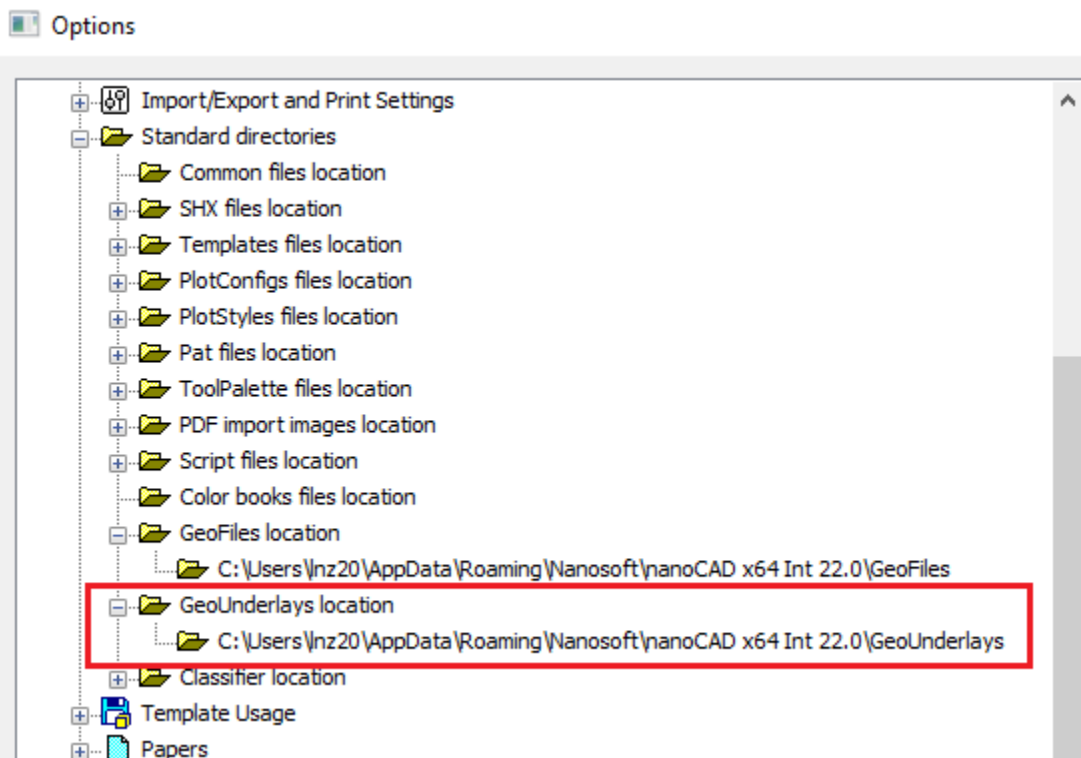

# THE COMPONENT LAYOUT AND PLOT DRAWING

## Model Space and Paper Space

The main working environment in nanoCAD is the *model space* intended for creating and editing objects.



*Paper space* is an auxiliary workspace that assembles various views created in model space for plotting. In paper space you can create various entities that will belong only to paper space, but will not be displayed in model space. Such objects are, for example, a format frame and main and additional titles, technical requirements, specifications, inscriptions, tables and other text and graphic information necessary to plot a drawing.

To transfer information from model space to paper space, it is necessary to create a *viewport*. A viewport is a kind of window from paper space to model space that displays some preset portion of model space. One layout can contain several viewports with different views. The image of the configured layout on the screen looks exactly the same as after printing on the plotter. For each layout, the format (sizes of the layout sides) and print settings are set independently. The layout content is displayed according to the plot style applied to that layout. For example, if you set the plot style to monochrome in the [Page setup](#) dialog, the layout content will also be displayed in black and white.

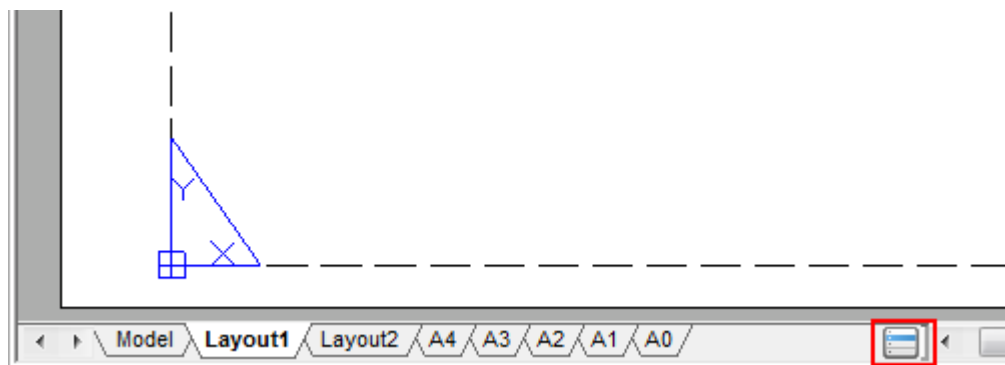
You can create multiple *named layouts* for a document. Tabs with layout names are located at the bottom of the document window, next to the **Model** tab. The **Model** tab and layout tabs allow you to pass to the workspace of the model or the corresponding layout. Switching between model space and created layouts is performed by clicking on the selected tab:



The display order of layout tabs can be changed by dragging the tabs to the left or right.

To quick switch between the model space and layouts, use the  button located at the beginning of tabs line. This button also allows you to switch between the named views available in the document. A click to the  button opens a context menu that displays all the layouts and named views available in the document:

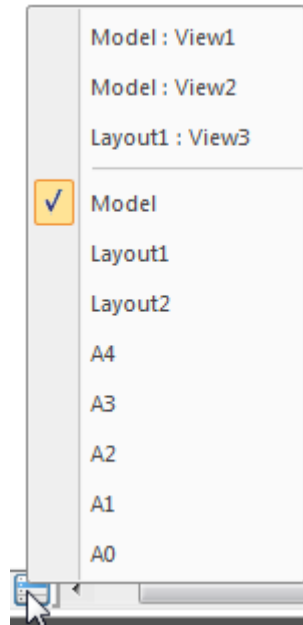

The top part of the menu displays the named views; the bottom part displays the **Model** layouts and space. The current space is marked with . To switch to a desired tab or desired named view, it is necessary to click on the corresponding item in the menu. When you switch to a named view, there is auto-panning of the view on the screen.

The display of layout tabs is enabled/disabled by  **Sheets Tabs** command located in the **View** menu and on the ribbon (**Manage** tab – **Customization** group).

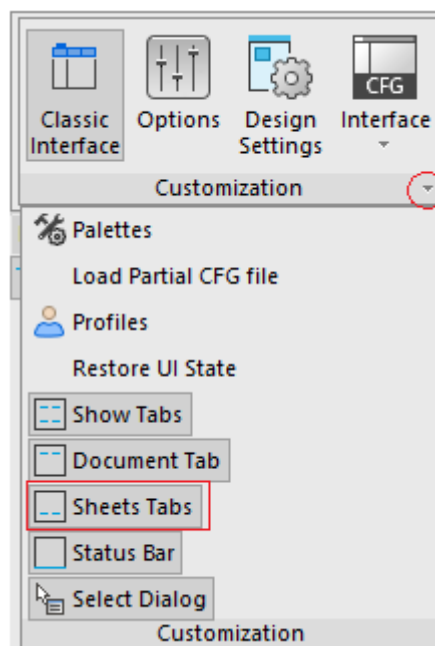

You can rename, delete and add layout tabs unlike the **Model** tab. The last (the only one in the document) layout tab cannot be deleted.

Another important difference between model space and paper space is that you create *non-overlapping* viewports in the model space, i.e. snap-together at the boundaries. In model space you can print only the current viewport. Viewports in the paper space are floating. They can be moved to any part of the layout. Their boundaries can be close to each other and overlapped or be located at some distance from each other. You can print all the viewports located on the layout at the same time.

To work with a layout, use the command from the **Insert** menu – **Layout** item, or from the **Layout toolbar**, from the **Layouts Manager** dialog box, or from the context menu that opens by right clicking the **Model** tab or a **Layout** tab.

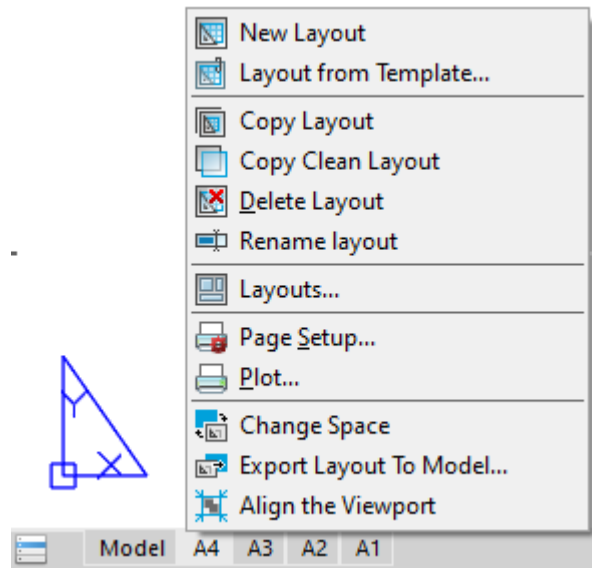

To create a new layout, use the **Add Layout** command. To delete a layout, use the **Delete Layout** command.

You can rename the current layout by double-click on its tab or by selecting the **Rename layout** command from the tab's context menu:

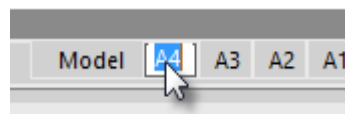

To rename any layout in a document, use a separate LAYOUT command.

The format of the displayed layout is set in the **Page Setup** dialog box.

**NOTE:** The print area of the layout for the current format settings and printer is displayed by a dashed line.

You can change the layout color in the **Options** dialog box using the **Color settings** item – **Layout Paper**.

When you prepare a layout, you typically go through the following process:

1. Create a model of your subject on the *Model* tab.
2. Click a *Layout* tab and specify layout page settings, such as plotting device, paper size, plot area, plot scale and drawing orientation.
3. Insert a title block into the layout.
4. Create a new layer to be used for the layout viewports.
5. Create the layout viewports and position them on the layout.
6. Set the orientation, scale and layer visibility of the view in each layout viewport.
7. Add dimensions and annotate in the layout as necessary.
8. Turn off the layer containing the layout viewports.
9. Execute the plot setting of the layout.
10. Plot the layout.

## Work with Layouts

The commands that work with layouts allows you to create new layouts, change existing layouts and save selected layouts in the file as a template.

The layout name that was set when you created, copied or renamed the layout, should be unique up to 255 characters (capitalization does not matter).

**NOTE:** No more than 31 characters of the layout name are displayed on the layout tab.

It is allowed to create up to 255 layouts in the single document.

To activate a layout (to set it current) just left click on its tab. The display order of layout tabs can be changed by dragging the tabs to the left or right. If there are many of layouts in the document, to move from one layout to another, use the  button. When you click on it, the context menu with a list of layouts opens:

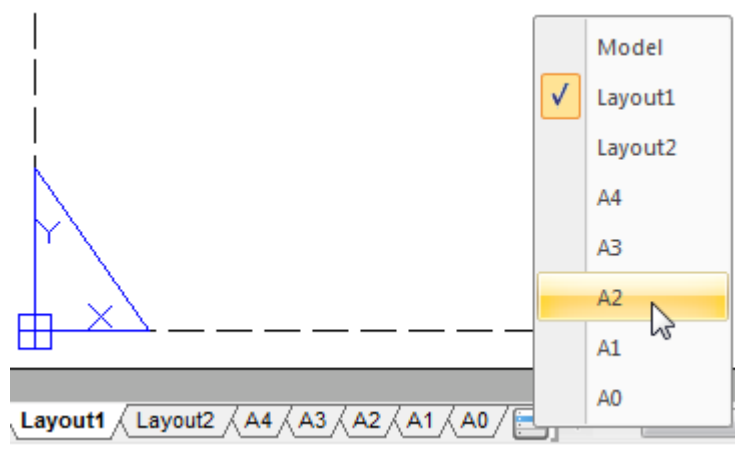

The current layout in the context menu is marked with the  icon.

You can rename the current layout by double-click on its tab or by selecting the **Rename layout** command from the tab's context menu:

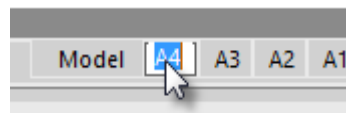

To rename any layout in a document, use a separate LAYOUT command.

## To Create a New Layout

 Ribbon: **Layout – Layouts** >  **Add Layout** (The **Layout** tab only appears when you are in paper space)

 Menu: **Insert – Layout** >  **New Layout**

 Layouts Manager dialog:  **Create new layout**

 Toolbar: **Layouts** – 

 Command line: **ADDLAYOUT**

At the command prompt - Input layout name <Layout3>, enter the name of the new layout and press **ENTER**.

By default, the new layout will have a name LayoutN+1, where N – the total number of layouts in the document.

The layout name should be unique up to 255 characters (capitalization does not matter).

The new layout is placed in the end of the layouts list of the document.

## To Create a Layout from a Template

 Ribbon: **Layout – Layouts** >  **Layout from Template**

 Menu: **Insert – Layout** >  **Layout from Template...**

 Toolbar: **Layouts** – 

 Layouts Manager dialog:  **Load layouts from template**

 Command line: **LAYOUTFROMTEMPLATE**

The command creates a new layout in the document.

The command allows you to create one or several layouts from an existing template file (\*.dwt) or drawing file (\*.dwg) or drawing exchange file (\*.dxf).

Start the command to open the **Open Document file** dialog box:

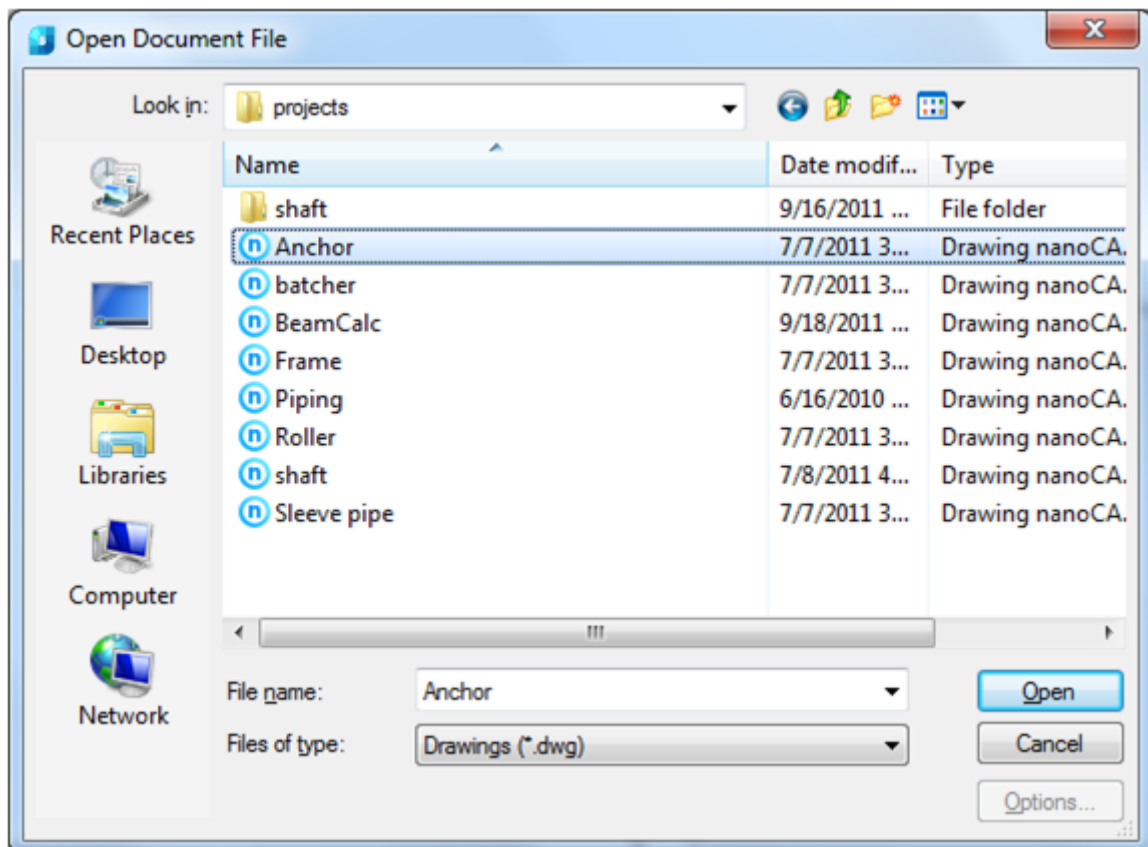

**To select a template in the Open Document File dialog box:**

1. Select the **\*.dwt** format from the **Files of type** list.
2. Select the folder where the template file or drawing file is stored.
3. Select the file.
4. Click **Open**.



5. Select one or several layouts in the **Insert Layout(s)** dialog box (use **SHIFT** and **CTRL** keys):

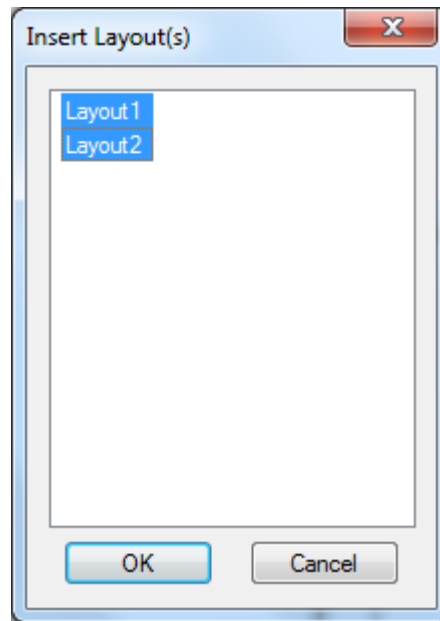

6. Click **OK**.

If the name of the inserted layout is the same as the name of a layout in the paper space, then the new layout will have a name consisting of the name of the existing layout, to which the name of the inserted layout is joined with an underscore character. For example, when you insert a layout called A4 into a document already having a layout with same name, a layout called A4\_A4 will be created. When you next insert the layout called A4, it will be created with the name A4\_A4\_A4 and so on.

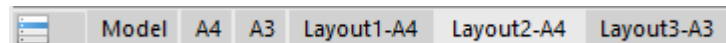

## Copy Layout



Ribbon: **Layout – Layouts** >  **Copy Layout** (The **Layout** tab only appears when you are in paper space)



Layouts Manager dialog:  **Copy layout**



Command line: **COPYLAYOUT**

This command copies all parameters and content of layout to the new layout.

The command offers to copy the last active layout by default:

Enter name of layout to copy <A0>:

To confirm, press **ENTER**, to copy another layout, input its name in the command line and then press **ENTER**.

Upon the prompt in the command line Enter name of layout to copy – specify the name for a new layout and press **ENTER**. If the name is not specified, the copy is assigned with the name of initial layout with the number (N), for example, A4 (2). Where (N) is a sequence number of the copy being created.

If the name being specified matches the name of an existing layout, a prompt is displayed in the command line with a choice of action:

Layout "A4" is exist. Replace it? <No> or [Yes/No]:

**ATTENTION!** Selecting the name of an existing layout (**Yes** option) will replace all preset parameters and contents of this layout with the parameters and contents of the copied layout.

**No** option will interrupt the copy process.

## Copy Layout without Viewport

 Ribbon: **Layout – Layouts >**  **Copy Clean Layout** (The **Layout** tab only appears when you are in paper space)

 Context menu:  **Copy clean layout**

 Command line: **LAYOUTCLEANCOPY**

The command allows you to copy all the content and parameters of layout with the exception of viewports.

By default, the command offers to copy the last active layout:

Enter name of layout to copy <Layout1>:

Press **ENTER** to confirm or input the name of another layout to copy it and press **ENTER**. Then input the name of new layout and press **ENTER**:

Upon the prompt in the command line Enter name of layout to copy – specify the name for a new layout and press **ENTER**.

Input layout name:

## Save a Layout as a Template

 Ribbon: **Layout – Layouts >**  **Save Layout as Template** (The **Layout** tab only appears when you are in paper space)

 Menu: **Insert – Layout > Save Layout as...**

 Layouts Manager dialog:  **Save layout as template**

 Command line: **LAYOUTTOTEMPLATE**

This command saves the created layout as a template with a **\*.dwt**, **\*.dwg** or **\*.dxf** extension.

The command prompts, by default, to save the last active layout:

Enter layout to save <A1>:

Press **ENTER** to confirm. Enter the name in the command line and press **ENTER** to save a different layout.

The command opens **the Save Document File** dialog box:

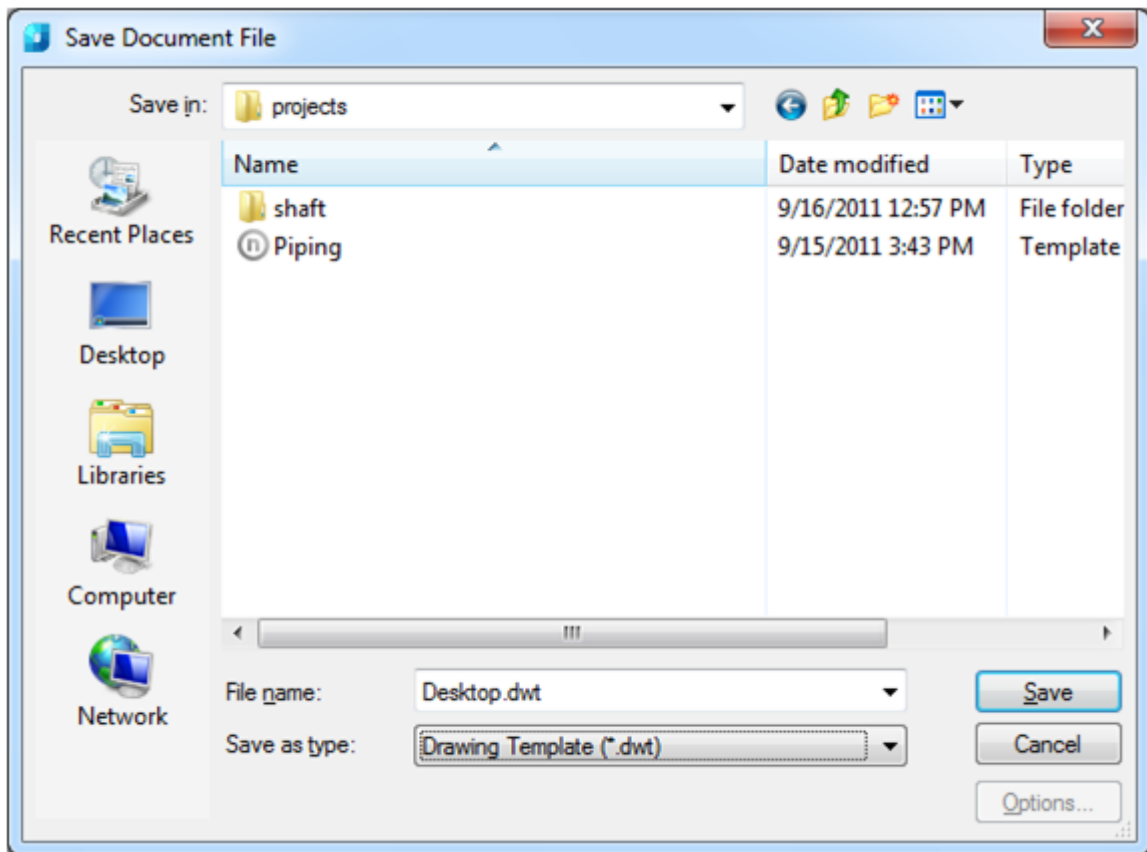



**To save a template in the Save Document File dialog box:**

1. Specify the path from the drop-down **Save in** list;
2. Enter a name into the **File name** field;
3. Select the *Drawing Template (\*.dwt)* format from the drop-down **Save as type** list;
4. Click **Save**

## Delete Layout

 Ribbon: **Layout – Layouts >**  **Delete Layout** (The **Layout** tab only appears when you are in paper space)

 Menu: **Insert – Layout >**  **Delete Layout**

 Layouts Manager dialog:  **Delete layout**

 Command line: **DELETECURLAYOUT**







This command prompts, by default, to delete the last active layout: Enter `layout` to delete <A1>:

Press **ENTER** to confirm. Enter the name in the command line and press **ENTER**, to delete a different layout.

You can delete a layout by right clicking on the layout tab and selecting the **Delete Layout** command from the context menu.

**NOTE:** The last layout in the document and the **Model** tab can not be deleted.

## Rename Layout

-  Ribbon: **Layout – Layouts** >  **Rename Layout**
-  Menu: **Insert – Layout** >  **Rename Layout**
-  Layouts Manager dialog:  **Rename layout**
-  Command line: **RENAMECURLAYOUT**

The command allows you to rename any layout in a document.



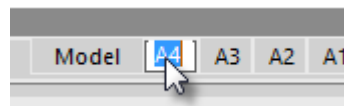

This command prompts, by default, to rename the last active layout. To rename another layout, enter its name in the command line.

After renaming the layout, its location in the document is not changed.

You can rename the current layout fast by double-clicking it on the tab or selecting the **Rename layout** command from the tab's context menu:



## Layouts Manager

-  Ribbon: **Layout – Manage** >  **Layout Manager**
-  Menu: **Insert – Layouts**
-  Command line: **LAYOUTSMANAGER**

The **Layouts Manager** dialog window allows you to manage the layouts of the document.

The dialog box displays a list of the layouts that contained in the document and information about their options.

The commands intended for work with layouts are represented by buttons located at the top right of the dialog box:

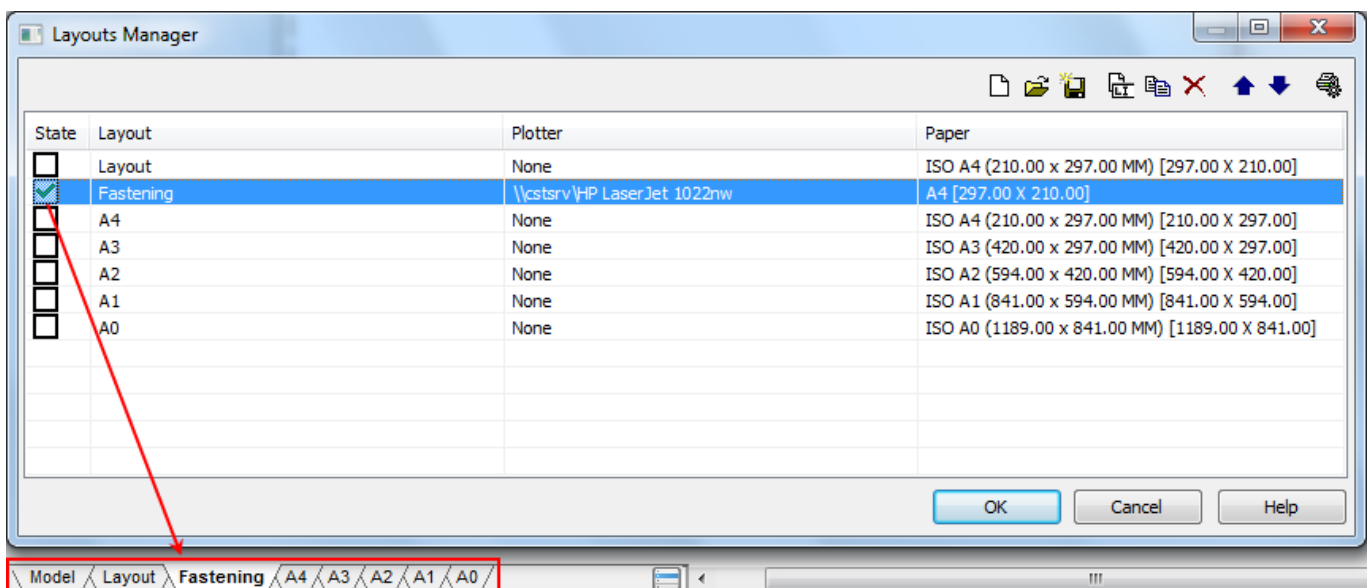

To make the current layout, you should double click on the layout.

To choose layout, for example to copy it, left click on the layout.

To navigate in the layouts list quickly, press (or press and hold) the **DOWN ARROW** key or **UP ARROW** key on the keyboard.









To select multiple layouts at once, use the **SHIFT** and **CTRL** keys:

- Holding the **SHIFT** key down selects all layouts located between the first and last clicks of the left mouse button.
- By holding the **CTRL** key down, any layout from the list can be added to an existing selection by clicking the left mouse button.

#### Information in the columns of the dialog box:

<b>State</b>	State of layout. The current layout is marked with <input checked="" type="checkbox"/> .
<b>Layout</b>	Name of layout.
<b>Page setup</b>	Displays the name of the set of options assigned to the layout in the <b>Page setup</b> dialog. If the sheet does not have an assigned set of options, <b>None</b> is displayed.
<b>Plotter</b>	The plotter name assigned to the layout.
<b>Paper</b>	Information about selected paper format for the layout.

#### Buttons

	<b>Create new layout</b>	Creates new layout.
	<b>Load layouts from template</b>	Creates a layout from an existing template file.
	<b>Save layout as template</b>	Saves a layout as template.
	<b>Rename layout</b>	Renames a layout.
	<b>Copy layout</b>	Copies a layout.
	<b>Delete layout</b>	Deletes a layout.
	<b>Move up</b>	Moves the layout up by one. The layout tab moves one position to the left.
	<b>Move down</b>	Moves the layout down by one. The layout tab moves one position to the left.
	<b>Page setup</b>	Opens the <b>Page Setup</b> dialog box to adjust the plotter settings.

#### To start the command:

1. Select a layout in the list of the dialog box.
2. Click the button of the necessary command.
3. If the command asks for a new layout name, type its name in a dialog box and click **OK**.

Applying the **Rename layout** and **Copy layout** commands to a multiple selection is accompanied by opening the **Name** dialog for each of the selected Layouts in turn.

## Managing Layouts from the Command Line



Command line: **LAYOUT**

The command allows you to manage the layouts from the command line.

After the command is started, the prompt of available options is shown in the command line:

Choose layout option

[Copy/Delete/New/Template/Rename/SAveas/Set]<Set>:

### Options:

#### Copy

Creates the layout copy.

By default, you will be offered to copy the layout that was current (active) before the command start.

The layout copy is placed in the end of the layouts list of the document

#### Delete

Deletes a layout.

By default, you will be offered to delete the layout that was current (active) before the command start.

The last layout in the document and the **Model** tab can not be deleted.

#### New

Creates a new layout.

By default, you will be offered to create a layout with a name LayoutN+1, where N – the total number of layouts in the document.

The new layout is placed in the end of the layouts list of the document.

#### Template

Creates one or several layouts from an existing template file (\*.dwt) or drawing file (\*.dwg) or drawing exchange file (\*.dxf).

The name and location of the template are selected in the **Open Document File** dialog box.

When you select the file, the **Insert Layout(s)** dialog box that displays all available layouts will appear.

When you select the layouts, they and all objects located on them will be inserted in the current document.

If the name of the inserted layout is the same as the name of a layout in the paper space, then the new layout will have a name consisting of the name of the existing layout, to which the name of the inserted layout is joined with an underscore character. For example, when you insert a layout called A4 into a document already having a layout with same name, a layout called A4\_A4 will be created. When you next insert the layout called A4, it will be created with the name A4\_A4\_A4 and so on.

#### Rename

Renames a layout.

By default, you will be offered to rename the layout that was current (active) before the command start.

When you rename a layout, its location in the document will not change.

#### SAveas

Saves a layout as template file (\*.dwt) or drawing file (\*.dwg) or drawing exchange file (\*.dxf).

By default, you will be offered a name of the layout that was current (active) before the command start.

When you set the file name, the dialog box, where you should select

the file name and type format as well as the storage location, opens.

### Set

Specifies the layout name to set it as the current (active).

By default, you will be offered to set the name of layout that was active before the command start for the current layout.

### Clean copy

Copies all layout settings and contents to a new layout, except for viewports.

## Export Layout to Model



Menu: **File** >  **Export Layout to Model...**



Layout context menu:  **Export Layout to Model ...**



Command line: **EXPORTLAYOUT**

Export of all visible object of the current layout to model space of a new drawing.

### *To export layout:*

1. Run **Export Layout to Model** command.
2. In **Export Layout to Model Space Drawing** dialog box specify the storage location and name the file.
3. Click **Save**.

To open the drawing in the current working session, click **Yes** in the open information window

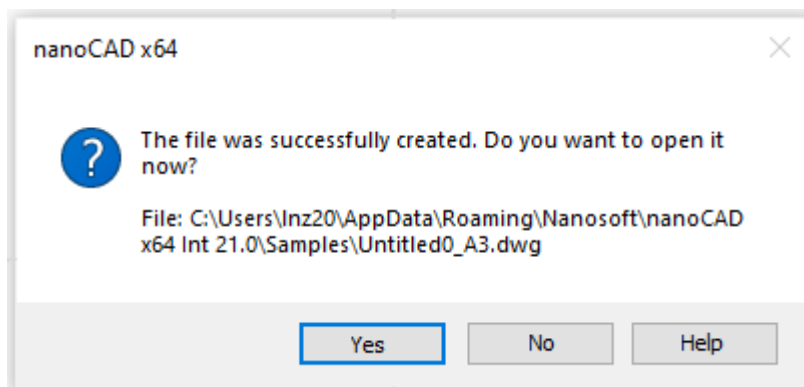

## Viewports









nanoCAD allows you to create layout viewports from the model space. You can create multiple layout viewports in the layout. Once you create the viewports, you can change their size, their properties and also scale and move them as needed.

The MAXACTVP system variable sets the maximum number of viewports (no more than 64 for each layout) the content of which is displayed at the same time. Viewports larger than the specified number will automatically turn off content display. When such a viewport is activated, the display of its content is turned on, but the display of another viewport's content will be "dimmed". The MAXACTVP variable has no effect on the number of viewports to be plotted.

It is important to create layout viewports on their own layer. When you are ready to plot, you can turn off the layer and plot the layout without plotting the boundaries of the layout viewports.

## Create Layout Viewports

### Create a Rectangular Viewport

-  Ribbon: **Layout – Layout Viewports** >  **Add Rectangle Viewport**
-  Menu: **View – Viewports** >  **Rectangular**
-  Menu: **Insert – Viewports in Layout** >  **Rectangular**
-  Toolbar: **Layout** – 
-  Command line: **ADDRECTANGLEVIEWPORT**

nanoCAD allows use of this command on the current layout tab in which the viewport should be located, as well as directly from the model space.

### Create a rectangular viewport from the model space

When you create a viewport from the model space, specify, with a frame, the drawing area (in the model space) that should be displayed in the viewport.

#### Command prompts:

- |  |   |
|--|---|
| Specify viewport first corner:                   | Specify the first corner of the rectangular viewport in the model space                                   |
| Specify viewport second corner:                  | Specify the opposite corner of the rectangular viewport in the model space                                |
| Input or choose view scale<br><Paper><1.000000>: | Select the name of layout in <b>Select Layout</b> dialog to insert a viewport and press <b>OK</b> button. |
| Specify Viewport Center Point:                   | Active before running of command layout is highlighted in the layout list.                                |
| Input or choose view scale<br><Paper><1.000000>: | Input the viewport scale.   |
| Specify Viewport Center Point:                   | Specify the viewport center point.  |

### Create a rectangular viewport from a layout

#### Options:

- |                          |   |
|--------------------------|---|
| <u>Extent</u>            | Displays all objects from the model space in the viewport.    |
| <u>Active</u> <0.000831> | Displays the current view of the model space in the viewport. |
| <u>Paper</u> <1.000000>  | Sets the viewport scale corresponding to the layout scale.    |

#### Command prompts:

- |                                |   |
|--------------------------------|---|
| Specify viewport first corner: | Specify the first corner of the rectangular viewport in the layout tab. |
|--------------------------------|---|





Specify viewport second corner:

Specify the opposite corner of the rectangular viewport in the layout tab.

Input or choose view scale <Paper> or [Extents/Active<0.000831>/Paper<1.000000 ≥>]:



Input the viewport scale or select the required option.

## Create a Polygonal Viewport

 Ribbon: **Layout – Layout Viewports** >  **Add Polygonal Viewport** (The **Layout** tab only appears when you are in paper space)

 Menu: **View – ViewPorts** >  **Polygonal**

 Menu: **Insert – ViewPorts in Layout** >  **Polygonal**

 Toolbar: **Layout** – 

 Command line: **ADDPOLYGONVIEWPORT**

nanoCAD allows use of this command on the current layout tab in which the viewport should be located, as well as directly from the model space.

### Create a polygonal viewport from the model space

When you create a viewport from the model space, specify the vertex points of the polygonal area of the drawing (in the model space) that should be displayed in the viewport.

#### Option:

Undo Consistently undo the specified points of the polygonal area.  
The start point cannot be undone.

#### Command prompts:

Specify start point:	Specify the start point of the polygonal vertex.
Specify next point or [ <u>Undo</u> ]:	Specify the second point of the polygonal vertex.
...	...
Specify next point or [ <u>Undo</u> ]:	Specify the end point of the polygonal vertex and press <b>ENTER</b> .
	Select the name of layout in <b>Select Layout</b> dialog to insert a viewport and press <b>OK</b> button.

Active before running of command layout is highlighted in the layout list.

Input or choose view scale  
<Paper><1.000000>:

Input the viewport scale.

Specify Viewport Center Point:

Specify the viewport center point.

## Create a polygonal viewport from a layout

### Options:

<u>Undo</u>	Consistently undoes the specified points of the polygonal area. The start point cannot be undone.
<u>Extent</u>	Displays all objects from the model space in the viewport.
<u>Active&lt;0.000831&gt;</u>	Displays the current view of the model space in the viewport.
<u>Paper&lt;1.000000&gt;</u>	Sets the viewport scale corresponding to the layout scale.

### Command prompts:

Specify start point:	Specify the start point of the polygonal vertex.
Specify next point or [ <u>Undo</u> ]:	Specify the second point of the polygonal vertex.
...	...
Specify next point or [ <u>Undo</u> ]:	Specify the end point of the polygonal vertex and press <b>ENTER</b> .
Input or choose view scale <Paper> or [ <u>Extents/Active&lt;0.000831&gt;/Paper&lt;1.000000&gt; ≥</u> ]:	Input the viewport scale or select the required option.

## Create a Viewport by Object

 Ribbon: **Layout – Layout Viewports >**  **Add Viewport by Object** (The **Layout** tab only appears when you are in paper space)

 Menu: **View – ViewPorts >**  **by Objects**

 Menu: **Insert – ViewPorts in Layout >**  **By Objects**

 Toolbar: **Layout –** 

 Command line: **DDOBJECTVIEWPORT**

This command allows you to convert a closed polyline, circle or ellipse into a viewport.

nanoCAD allows use of this command on the current layout tab in which the viewport should be located, as well as directly from the model space.

## Create a viewport by object from the model space

### Options:

<u>?</u>	Calls additional options to select the objects.
<u>Extent</u>	Displays all objects from the model space in the viewport.
<u>Active&lt;0.000831&gt;</u>	Displays the current view of the model space in the viewport.
<u>Paper&lt;1.000000&gt;</u>	Sets the viewport scale corresponding to the layout scale.

When you start the command, the **Select Layout** dialog box opens. Select the layout on which you want to place the viewport.

By default, you will be offered the layout that was current (active) before the command start.

**Command prompts:**

Select closed object to create viewport or [?]:

Select the closed object.

Input or choose view scale <Paper> or [Extents/Active<0.000831>/Paper<1.000000>]:

Input scale of the viewport or select necessary option.

**Create a viewport by object from a layout**

**Options:**

- ? Calls additional options to select the objects.
- Extent Displays all objects from the model space in the viewport.
- Active<0.000831> Displays the current view of the model space in the viewport.
- Paper<1.000000> Sets the viewport scale corresponding to the layout scale.

**Command prompts:**

Select closed object to create viewport or [?]:

Select the closed object.

Input or choose view scale <Paper> or [Extents/Active<0.000831>/Paper<1.000000>]:

Input scale of the viewport or select necessary option.

**Edit Layout Viewports**

You can redefine the boundary of a layout viewport by using the grips. You can either use the multi-feature modes for grips editing of viewports which are used as the boundary of the closed polylines and splines (for more information, see «Editing viewports of paper space»). The type and location of grips depend on the type of viewport or the object from which it is converted:

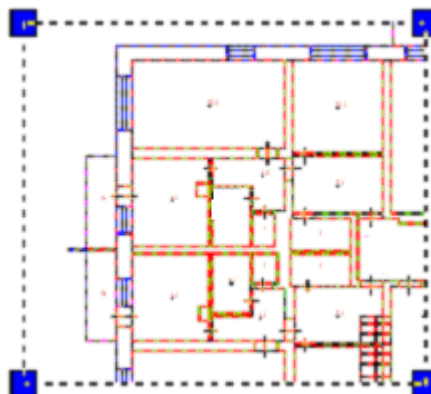

The following editing commands can be used with the selected viewport: **Copy, Move, Scale**, etc.

You can copy and move the viewports to the clipboard and paste them from the clipboard.

The clipboard options can be modified in the **Properties** panel:

Misc	
On	Yes
Display locked	No
StandardScale	1:1
Scale	1.0000
Clipped	Yes
Layer property overrides	No
Shade plot	As displayed

To turn on/off the content display of the viewport, use the **Yes** or **No** options from the drop-down list of the **On** option (or use the **ON/OFF** command from the **View** menu – **Viewports** item):

Misc	
On	Yes
Display locked	No
StandardScale	1:1
Scale	1:1 1:2
Clipped	1:4
Layer property overrides	1:8 1:10
Shade plot	1:16 1:20

The objects on the turned off viewport are invisible. You cannot set as default the turned off viewport. A large number of active (with turned on visibility of content) viewports requires considerable time for regeneration. Turn off the visibility of some unused viewports to improve the regeneration of the document. You can move and resize the deactivated viewports. The deactivated viewports are not printed.



The **Display locked** option allows you to block or unblock a viewport (**Yes** and **No** options are available in the drop-down list). A similar function is performed by the **Lock/Unlock** command from the **View** menu – **Viewports** item. Locking a viewport used to previously set the scale of a viewport remains unchanged (viewport zoom does not affect the viewport scale).

The **Standard Scale** and **Scale** option allows you to set or change the scale of the displayed view in a viewport. For example, if a drawing fragment is created in 1:1 scale and you want to specify 1:4 scale for it, it is necessary to enter 0.25 value in the right column of the **Scale** option or select 1:4 from the drop-down list of the **Standard Scale** option:









Misc	
On	Yes
Display locked	No
Standard Scale	1:1
Scale	1:1 1:2
Clipped	1:4
Layer property overrides	1:8 1:10
Shade plot	1:16 1:20

The view scale of a viewport is not changed when you edit the boundaries of the viewport; for example, when you modify a boundary by grips. If you set the scale in the layout viewport before you access the model space, you can lock the scale to prevent changes. When the scale is locked, you cannot use zoom while you work in model space

You can clip the boundaries of the viewports (the **Modify** menu – **Clip – Viewport**).

The viewport allows you to edit the objects of the model space from the layout. If there are several viewports in model space, use **CTRL+R** combination to change current viewport. If you are in paper space, double-click within a layout viewport. You are now in model space. The selected layout viewport becomes the current viewport, and you can pan the view and change the layer properties. If you are in model space in a layout viewport, double-click outside the viewport. To switch quickly from a viewport in layout, use the  button in the status bar. Located next, the  button performs switching from the layout back into the viewport.

Set parameters of viewport in a command line:

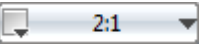
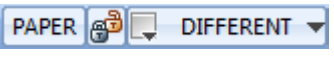
Button	Value/Action
	Current space – Model. Click  to cross to paper space.
  Paper Lock	Current space – Paper. No selected viewports. Click  to cross to viewport.
	Current space – Paper. Viewport is selected or active.
 Lock viewport	Off. Click the button to lock a viewport.
 Lock viewport	On. Click the button to unlock a viewport.
	Scale of selected or active viewport. Click the arrow to select new value.
	Several viewports with different scales and lock parameters are selected.

## Aligning Viewport Objects



Ribbon: **Layout – Layout Viewports >**  **Align**



Menu: **View – Viewports >**  **Align the Viewport**



Command line: **ALIGNSPACE**

The command allows you to adjust the pan and zoom factor of objects in a layout viewport by specifying alignment points in model space and paper space.

Specifying one point in model space and one point in paper space will offset the view.

### Offset – command prompts:

FIRST alignment point in MODEL space:

Specify the point in the active viewport.

SECOND point in MODEL space or <Return> for none:

Press **ENTER**

Alignment point in PAPER space:

Specify the point where the first point will be moved.

By specifying two points in model space and two points in paper space, you can set scaling, moving and rotation.

Points specified in model space are aligned to points specified in paper space. Zoom factor and UCS rotation are adjusted according to specified points.

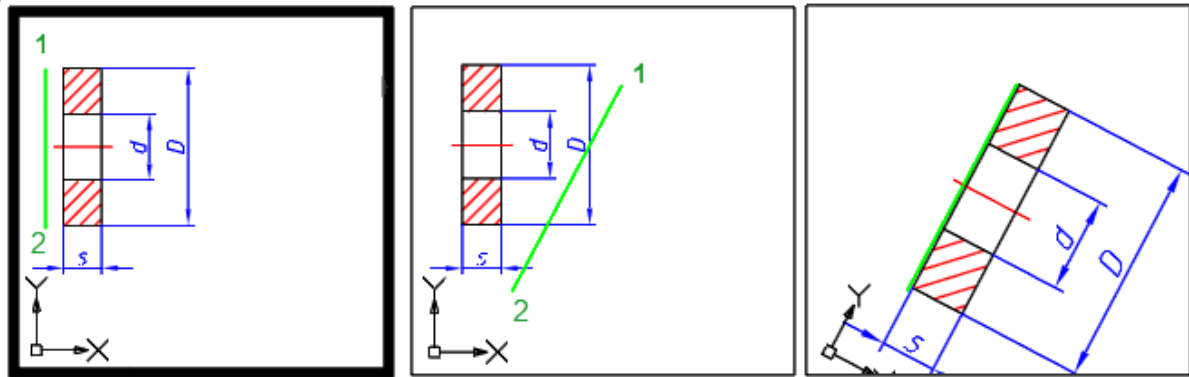

### Command prompts:

FIRST alignment point in MODEL space:

Specify the point in the active viewport.

SECOND point in MODEL space or <Return> for none:

Specify the second point in the active viewport.

FIRST alignment point in PAPER space:

Specify the first point in the paper space.

SECOND alignment point in PAPER space

Specify the second point in the paper space.

## Set Show Boundary for a Viewport



Ribbon: **Insert – Reference – Clip** >  **Viewport Clip**



Menu: **Modify – Clip** >  **Viewport**



Command line: **VPCLIP**

This command allows you to change the border of the created layout viewport.

When you select a viewport, the **Viewport** command will be available from the context menu:

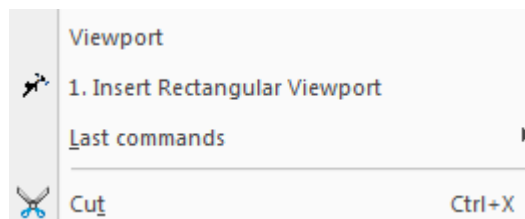

Use the command to clip the border of the viewport and objects displayed on the viewport. The show boundary only defines the objects' visibility option in the viewport, the objects do not change on the drawing.

### Options:

?

Calls additional options to select the objects.

Polygonal

Sets the polygonal contour of the show boundary by specifying all the polygon vertices.

Undo

Undoes the specified points of the polygon vertices.  
The start point cannot be undone.

Object

Sets the boundary contour by specifying the closed object.

The object should already be created.  
 You can use circles, ellipses, closed polylines and closed splines as objects.

Viewport before setting the display boundary

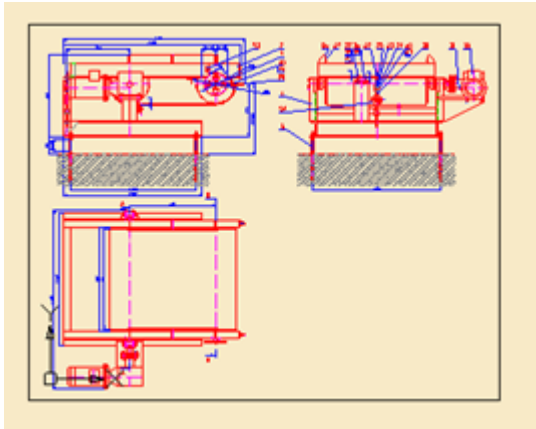

Viewport display after setting a polygonal display boundary

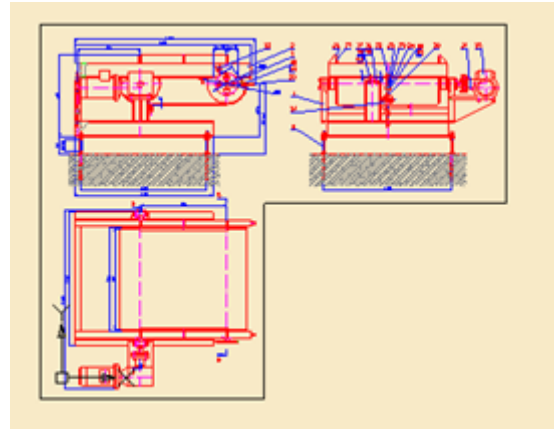

**Command prompts when you set polygonal boundary:**

Select viewport to apply action or [?]:  
 Specify clipping option <Polygonal> or [Polygonal/Object/Delete]:  
 Specify start point:  
 Specify next point or [Undo]:

Select the viewport.  
 Select the Polygonal option.  
 Specify the start point.  
 Specify the second point.

Specify next point or [Undo]:







Specify the end point and press **ENTER**.

**Command prompts when you set boundary by object:**

Select viewport to apply action or [?]:  
 Specify clipping option <Polygonal> or [Polygonal/Object/Delete]:  
 Select closed object to create viewport:

Select the viewport.  
 Select the Object option.  
 Select the closed object.

## Change Space

-  Ribbon: **Layout – Layout Viewports >**  **Change Space**
-  Menu: **Modify >**  **Change Space**
-  Layout context menu:  **Change Layout**
-  Command line: **CHSPACE**

Transfers selected objects between model space and paper space.  
 The command is available only in paper space in presence of active viewports.  
 The transferred objects are scaled automatically in the new space.

### *Transfer of paper space objects to the model space selected in the layout viewport*

Select objects or [?]:

Set the TARGET viewport active and press ENTER to continue:

Select paper space objects.

Click inside layout viewport to make it current and press **ENTER**. The transferred objects are scaled automatically to preserve visual representation.

### *Transfer of model space objects to paper space*

Select objects or [?]:

Set the SOURCE viewport active and press ENTER to continue:

Select model objects in the active layout viewport.

Click inside layout viewport to make it current and press **ENTER**. The transferred objects are scaled automatically to preserve visual representation.

If there is only one viewport in the paper space, the selected objects are transferred without additional prompts with information about the scale factor value:

Objects were scaled with factor 10.893 to preserve visual representation.

## Document Plot

*To print a document, it is necessary:*

1. In the **Layers** dialog box (**Format** menu – **Layers...**) for layers that should be printed:
  - turn on the visibility of disabled layers;
  - thaw the frozen layers;
  - turn on the availability to print.
2. If necessary, set the display order of objects in a document by **Tools** menu – **Display Order** commands.
3. Specify the printer settings for each document layout:
  - right-click on the **Model** tab or a corresponding tab in a layout space;
  - in the opened context menu select the **Page Setup** command:

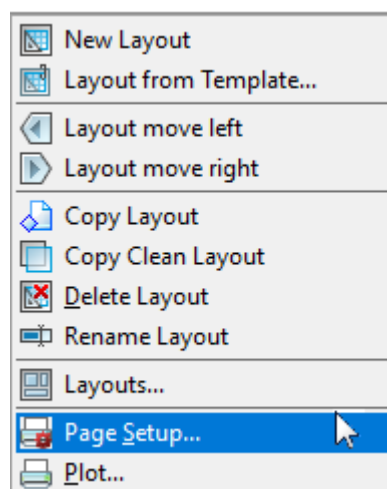





- create a new, edit existing or import the parameters set of a page previously created in another document;
- when creating a new or editing an existing parameters set of a page, specify the required settings in the **Page Setup** dialog box;
- click the **Apply to Page** button to apply the selected parameters set to the current layout and close the dialog box.
  4. Send the task to the printing device (**File** menu, **Plot** or **Batch plot** commands).

## Page Setup Manager

 Ribbon: **Output – Plot** >  **Page Setup Manager**

 Menu: **File** –  **Page Setup Manager ...**

 Toolbar: **Main** – 

 Command line: **PAGESETUP**

When preparing a document for printing, it is necessary to set a sufficiently large number of parameters for each layout: select the printer, specify the paper size and orientation, set the plotting scale, etc. The **Page Setup Manager** allows you to save plot setup parameters in the named page setups. The use of named page setups makes it possible to significantly reduce the time for preparing documents to plot due to applying previously made plot settings to new document layouts.

With help of **Page Setup Manager**, it is possible to create new setups, edit those previously created in the current document or imported from other documents. The page setups are assigned to each document page and are stored in a document file.

Upon starting the command, the **Page Setup Manager** dialog box opens. The name of the current layout is displayed in the dialog box title in square brackets:

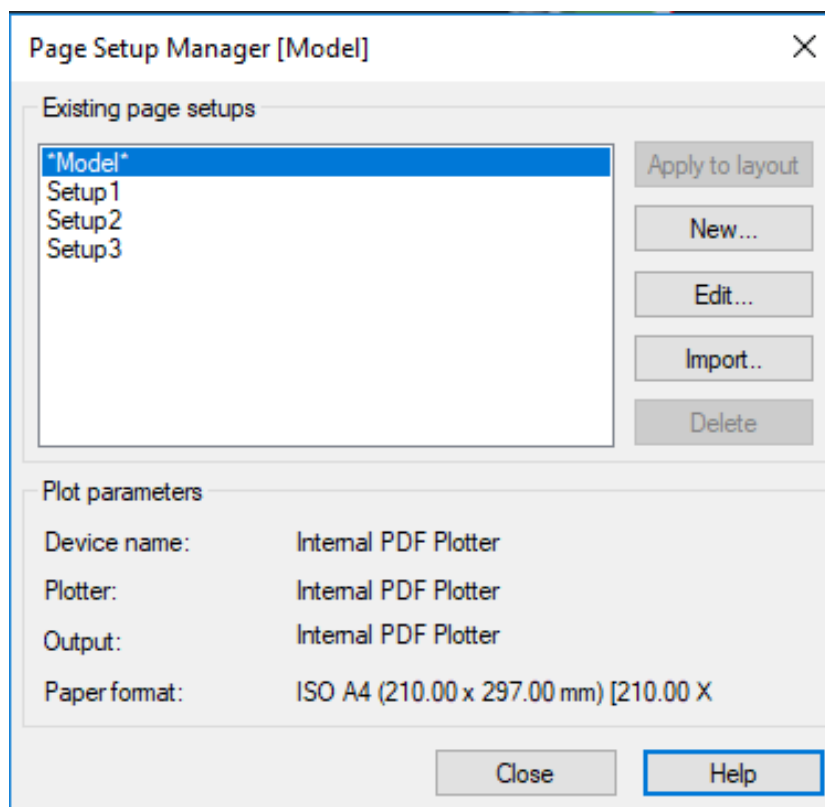

## Options:

### Existing page setups

Apply to layout

In the top left part of the section the list of page setups applicable to the current layout is displayed.

In the absence of created page setups in the document, the list displays only the current layout name, marked with asterisks (for example, *\*Model\**, *\*Layout1\** etc.), to which created or imported page setups may be applied.

Button to assign the page setup selected in the list to the current layout. The layout name is added with the name of assigned page setup in parentheses, for example, *\*Model(Setup1)\**, *\*Layout1(Setup2)\** etc.

**NOTE:** When selecting the current layout in the list, the **Apply to layout** button is not available.

New...

Button for opening **New Plot Set** button, where it is possible to select an earlier created setup as a template and enter a name for the new setup.

Edit...

Button for opening **Page Setup** dialog box for editing settings for the selected setup.

Import..

Button for opening a standard dialog box for selecting files, where it is possible to select a file to import one or more page setups from it.

Delete

Button to delete the selected page setup.

### Plot parameters

Displays information about the selected page setup.

**Device name:**

Name of the plot device assigned to the setup.

**Plotter:**

Type of the plot device assigned to the setup.

**Output:**

Physical location of the plot device assigned to the setup.

**Format:**

The name of paper format parameters assigned to the setup. The paper size and orientation are displayed in square brackets [ ].

**NOTE:** The name of the paper format can include the paper size, which is displayed in round brackets ( ).

**NOTE:** The page setups created for the layout space are not applied to the model space. Conversely, the page setups for the model space cannot be applied to the layout space.

### To create the page setup:

1. Click the **New** button.
2. In the opened **New Plot Set** dialog box

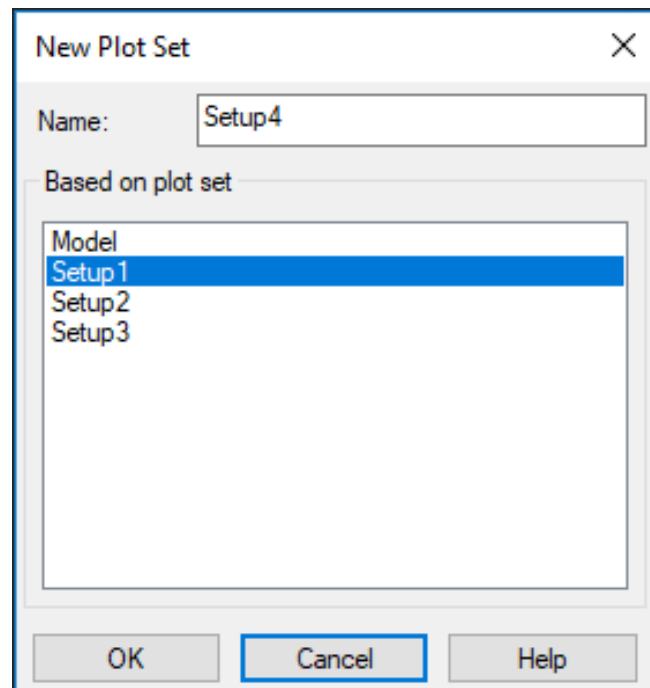

in the **Based on plot set** section, select a previously created setup as a template.

3. In the **Name** field, enter the name of a new setup.

**NOTE:** By default, for a newly created page setup the following name is proposed *SetupN*, where *N* is the number of the setup being created. For convenience it is recommended to assign a user name to the new setup, which displays the format name and orientation, assigned plotter name, etc., for example, *A4 (portrait) PDFCreator* or *A1 (landscape) CanonLargeFormat W7250*.

4. Click **OK** button.
5. Specify the necessary parameters in the **Page setup** dialog box and click **OK** button.

The newly created setup is displayed in the **Existing page setup** list of the Page Setup Manager.

#### **To edit the page setup:**

1. Select the setup for editing in the **Existing page setup** list.
2. Click the **Edit** button.
3. Make the required changes of parameters in the opened **Page Setup** dialog box.
4. Click **OK** button.

#### **To import the page setup:**

1. Click the **Import** button.
2. In the opened standard file selection dialog box, select the type of file, folder in which it is located, and the file itself.

**NOTE:** It is possible to import page setups from the drawing format (\*.dwg), drawing template (\*.dwt) and drawing interchange format (\*.dxf).

3. Select one or more page setups in the **Import page setup** dialog box (using the **SHIFT** and **CTRL** keys).

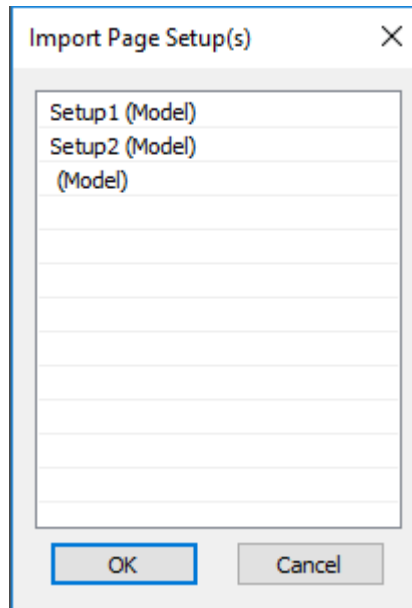

4. Click **OK** button.

**To delete the page setup assigned to the current layout:**

1. Select the page with an assigned setup in the **Existing page setup** list, for example, *\*Model(Setup1)\**.
2. Click the **Edit** button.
3. In the **Page Setup** dialog box choose the **None** option in the available plot devices list.
4. Click **OK** button to close the dialog.
5. In the **Page Setup Manager** dialog box, the name of the assigned setup will be deleted from the page name, i.e. the page name for the above example will be: *\*Model\**.
6. Click to select the page setup (*Setup1* in this case). The disabled **Delete** button becomes available (enabled).
7. Click the **Delete** button.
8. To close the dialog, click the **Close** button.

## Page Setup

The **Page Setup** dialog is opened from the **Page Setup Manager** at creating or editing a page setup (the **New** and **Edit** buttons):

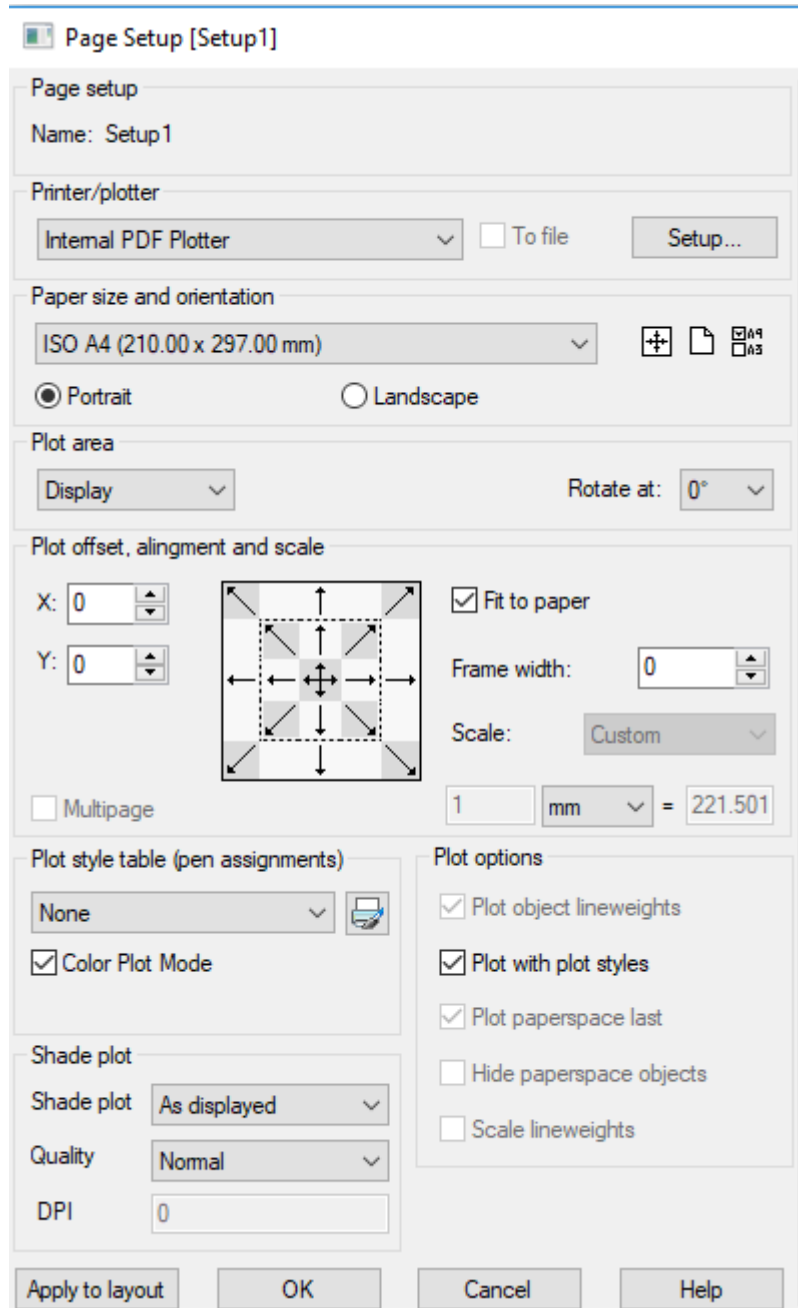

### Options:

#### Printer/Plotter

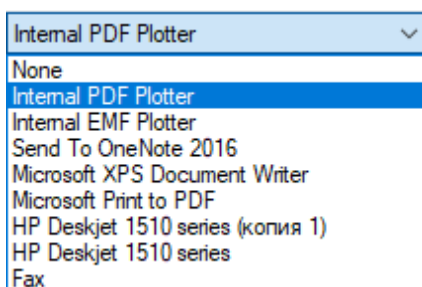

Drop-down list that displays the available plot devices.

#### To file

Turns on/off the print mode into the plt-file.

When **To file** option is turned (checkbox is selected), clicking the **Plot** button (in the **Plot** dialog box) opens the **Plot to file** dialog box (standard dialog box to store files) to select the folder for storing plt-file.



Button to open the dialog box to modify the current settings of the selected plot device.

The view of the opened dialog box and configuration settings are determined by the driver of the current plot device.

### Paper size and orientation

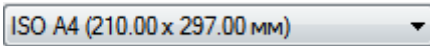

Drop-down list to select paper formats for the current plot device.

**Portrait**

Setting the paper orientation

**Landscape**



**Find the nearest paper**

Button for automatic search of the optimal paper format for the specified plot area and the selected plot device from the plotting fields.

The selected optimal paper format allows you to print the defined plot area without cutting in boards.

Attention: The size of the optimal paper format selected in this way should be checked against the size of paper actually used in the plot device.



**Add custom paper size**

Button to set parameters of a new paper format. Opens the [Modify paper format](#) dialog box.



**Filter paper**

Button to create a set of paper formats to be included in the **Paper size and orientation** drop-down list. Opens the [Edit paper list](#) dialog box.

### Plot area

Model	Layout
Limits	Layout
Display	Display
Extents	Extents
Limits	Layout
Window	Window

Drop-down list to select the drawing area to be plotted. The list view depends on the current **Model** or **Layout** space.

Options for setting the plot area:

**Display**

Plots the view in the current viewport in the model space and in the current view in the layout space.

**Extents**

Plots the drawing's portion that currently contains objects. All objects of the current space are plotted.

**Limits**

Plots the document objects within the set grid limits (**Grid > Drawing limits**). The option is available in the **Model** space.

**Layout**

Plots all objects located in the layout. The option is not available in the model space.

**View**

Plots the named view. The named view is selected from the drop-down list:





**NOTE:** If the document does not contain named views, the option is not displayed in the drop-down list.

## Window

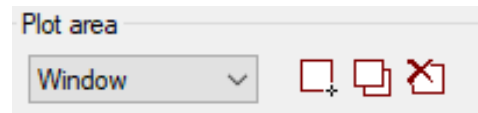
Specifies the plot area by a rectangular selection window. When selecting this option, the dialog box is temporary closed and in response to the command line prompt: *Specify First Corner or [Select]*: it is possible to specify the plot area on the display by indicating two opposite corners of the rectangle. The *Select* option allows you to specify the plot area by selecting one side of the frame that limits the paper format. In this case the size and orientation of the plot area is determined by the parameters specified in the **Paper size and orientation** section. After specifying the first plot area by the window, additional buttons are displayed in the dialog box:



 **New window print area** – cancels all specified plot areas by setting a new area.

 **Add window print area** – adds the plot area to those already specified.

 **Delete last print area** – sequential removal of the specified plot areas one by one in the reverse order of their assignment.

## Turn

Drop-down list to select a turn angle of the specified plot area. Angles of 0, 90, 180 and 270 degrees are available for selection.

### *Plot offset, alignment and scale*

X:

Field to specify the offset value of the plot area relative to the lower left corner of plotted page in the X direction.

Y:

Field to specify the offset value of the plot area relative to the lower left corner of the plotted page in the Y direction.

**ATTENTION!** Offset is specified when the alignment mode is disabled. To disable the alignment mode, it is necessary to click repeatedly the highlighted arrow button on the alignment icon.

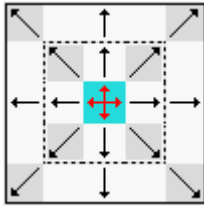

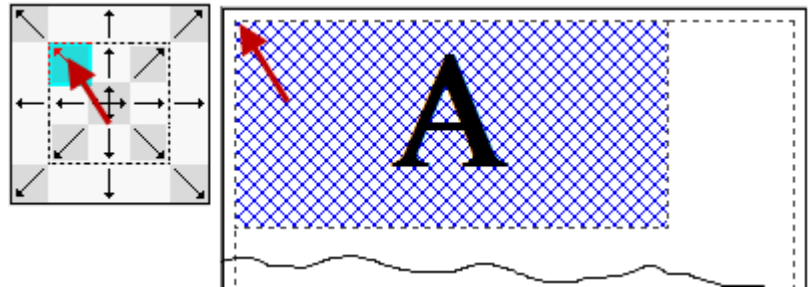

The icon with buttons of alignment of the plot area on the sides of the paper format.

The buttons bounded by a dashed line produce a shift of the plot area to indentations determined by the plotter's print margin.

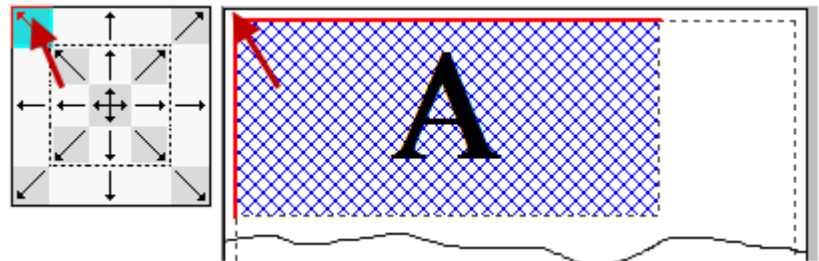

Buttons of the outer frame shift the plot area to the edges of the selected paper, margins of indentation to the plotter's print margins are ignored.



The central button  controls the automatic determination of offsets in X and Y direction so that the drawing is located in the page center (automatic drawing centering).

## Multipage

Turns on/off the multipage plot mode.

The mode is used to print large formats on printers that do not support such formats. For example, for plotting A1 format on A4 printer.

The option is available, when **Fit to paper** option is off.

## Plot scale

### Fit to paper

Turns on/off the mode of adjusting the plot area scale so that it perfectly fits the page of current format.

### Frame width:

Option to set the parameter of considering weight of the frame line defining the drawing boundaries and coinciding with the plot area boundaries. When setting a parameter value equal to the frame line weight, the frame is printed without reducing its thickness.

For example, if the parameter value is equal to zero, the frame created by lines of 1 mm weight will be printed at 0,5 mm thickness.

When setting the parameter to 1 mm value, the frames will be printed at 1 mm thickness.

**NOTE:** The **Frame width** option works only when the **Fit to paper** mode is on.



**Scale:**

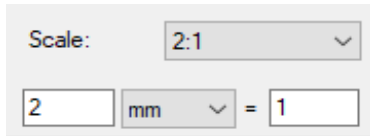

Drop-down list to select the standard scale values.  
Selecting measurement units (inches or mm) and setting the plot scale.

*Plot style table*



Drop-down list to select the plot style table.

**Color Plot Mode:**

Manages the display of plot style tables in the drop-down list for selecting the plot style table.

When the checkbox is switched on, the list displays the color plot styles (\*.ctb), when the checkbox is off – the named ones (\*.stb).



Button to open the **Plot Style Table Editor** dialog box to edit the specified plot style table or create a new one.

*Shaded viewport*

**Shade plot:**

Drop-down list to select the plotting option for shaded and rendered 3D models.

Available options are:

- **As displayed** – Objects are plotted as they are displayed on the screen.
- **Wireframe** – Only objects in wireframe are plotted, regardless of the way they are displayed on the screen.
- **Hidden** – Hidden lines of objects are not plotted, even if they are displayed on the screen.
- **Rendered** – Plots the objects as rendered, regardless of the way they are displayed on the screen.

**Quality:**

Drop-down list to select quality options for plotting shaded and rendered viewports of 3D models.

Available options are:

- **Draft** – Plots objects in a wireframe mode.
- **Preview** – Plots objects at the ¼ of the current plot device resolution (maximum – 150 dpi).
- **Normal** – Plots objects at the ½ of the current plot device resolution (maximum – 300 dpi).
- **Presentation** – Plots objects at the current resolution of the plot device (maximum – 600 dpi).
- **Maximum** – Plots objects at the current plot device resolution with setting no maximum limit.
- **Custom** – Plots objects at the resolution, which is specified in the DPI box. The resolution specified by the user cannot exceed the current resolution of the plot device.

**DPI:** Field to specify the plot resolution.  
The option is available, when selecting the **Custom** option in the **Quality** list.

### Plot options

The section to specify options that allow switching between ready-configured plot-style (\*.ctb or \*.stb files) and customized settings for the display properties of objects in the current document.

- Plot object lineweights** Turns on/off the plot mode considering the lineweights assigned to objects and layers.
- Plot with plot styles** Turns on/off the plot mode considering the plot styles assigned to objects and layers.  
When selecting this option, the **Plot Object Lineweights** option is also enabled automatically.
- Plot paper space last** Turns on/off the mode to plot model space objects first.
- Hide paper space objects** Turns on/off the mode that applies **Hide** command to objects in the paper space viewport.  
The option is available only for a layout space.  
The option is active only when plotting and in the preview of plot results.
- Scale lineweights** Turns on/off the mode of scaling lineweights to plot from the Layout space.  
Lineweight changes in accordance with the scale specified in the **Scale** section.

### Buttons to manage the specified plot setups

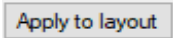
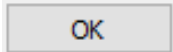
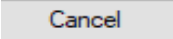
-  Button to apply the named page setup to the current layout.  
The name of the page setup applied to the layout is displayed when plotting this page in the title of the **Plot** dialog box.
-  Button to save settings and move to the **Page Setup Manager** dialog box.
-  Button to close the dialog without saving the plot setups.

## Saving Plotter Settings to PC3 File

The drop-down list in the **Plotter** section contains a list of all plotters registered in the system. Their parameters are edited by clicking **Setup** button to the right of the list.

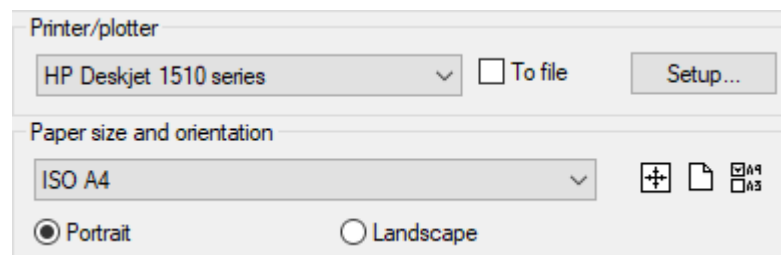

The settings dialog that opens is individual for each printing device. When you finish changing the settings, when you close the dialog, you will be prompted to save the settings as a separate file with the PC3 extension so that you can reuse it.

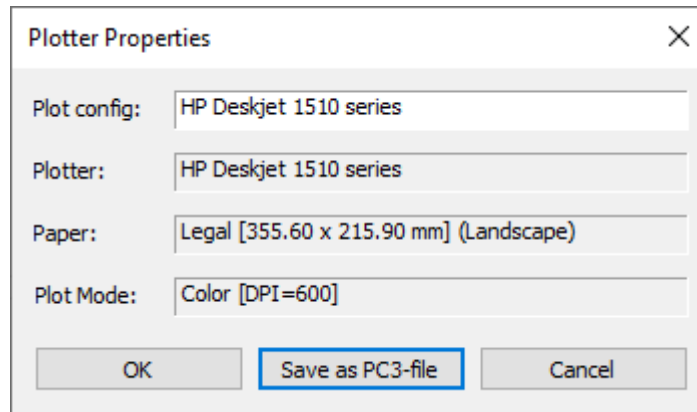

After that, the saved configuration can be selected in the list of printers.

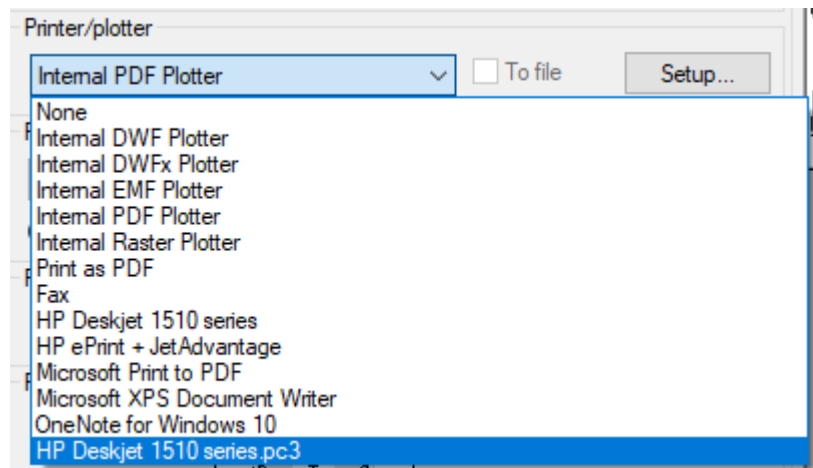

A file of the same name with the PC3 extension will appear in the plot configuration files directory.

Such plotter configurations can be transferred to different computers and shared among team members, provided that they use the same driver version and plotter model. If you update the plotter driver version, the old PC3 file may not work. Plot configurations for system plotters can also be shared, but should be in the same version of the operating system.

## Paper Formats

### Modifying and Adding the Paper Formats

The composition of paper formats list of the **Paper size and orientation** section in **Plot** and **Page Setup** dialog boxes depends on formats specified in the **Papers** section of **Options** dialog (the **Tools** menu – **Options**). In the same section it is possible to change the existing paper format or create a new one.

#### To edit the list of paper formats:

1. Enter the **Papers** section of the **Options** dialog box.
2. Set the label of formats that should be displayed in the list:

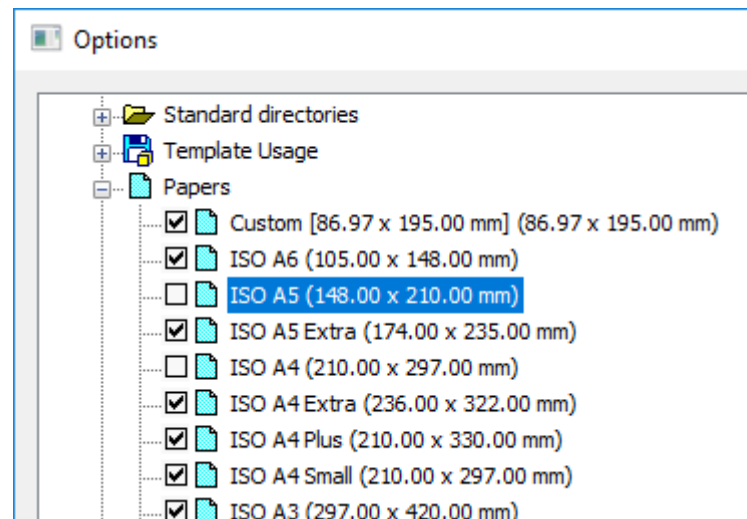

**To add a new paper format:**

1. Select the **Papers** section name of the **Options** dialog box. To create a new paper format based on the existing one, select the required format in the section list.
2. Click the **Add** button.
3. In the opened **Add paper format** dialog box:
  - specify the new format name;
  - select the measurement units;
  - enter the values of format width and height;
  - if necessary, set size of the internal frame: set the **Internal frame** mark and specify the values of margins from the format edge in the **Frame margins** section:

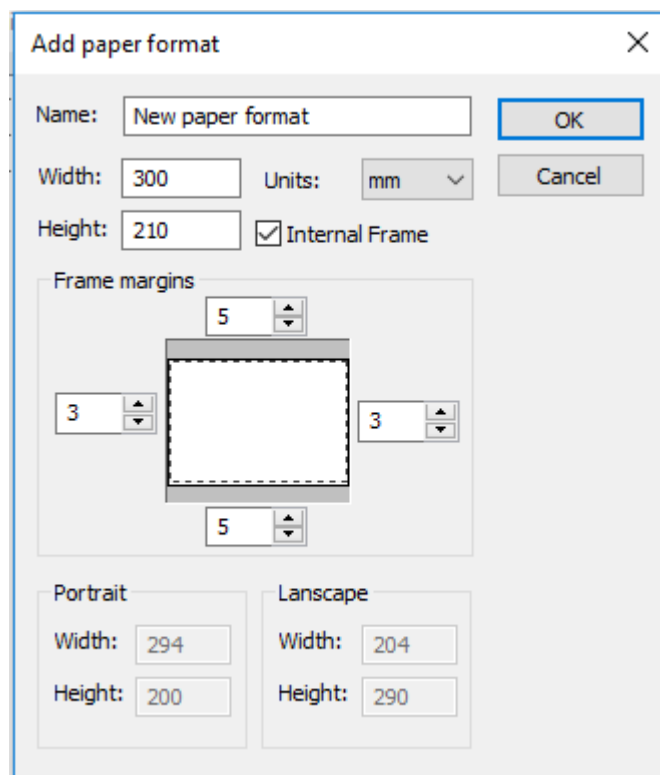

**NOTE:** The plot area sizes are set depending on the specific plot device used, as they are determined by the plot device manufacturer.

**NOTE:** When setting the paper size, it is necessary to consider the minimum and maximum acceptable sizes for the specific plot device used, which are also determined by the plot device manufacturer.

4. Click **OK** to close the dialog box.
5. Click **OK** to close the **Options** dialog box.

**To modify a paper format:**

1. Enter the **Papers** section of the **Options** dialog box.
2. Select the format to be modified.
3. Click the **Modify** button.
4. In the opened **Modify paper format** dialog box, repeat actions of 3-5 items from the previous section. You should not change the format name.

The newly created paper formats are displayed in the **Paper size and orientation** drop-down list in the **Plot** and **Page Setup** dialog boxes after selecting a specific plot device.

**ATTENTION!** The paper formats for which the specified sizes are more or less than those acceptable for a specific plot device are not displayed in the **Paper size and orientation** list for this device.

## **Editing the List of Paper Formats**

The content of the drop-down list for selecting paper formats of the **Paper size and orientation** section in the **Plot** and **Page Setup** dialog boxes can be edited.

The  **Filter paper** button of the **Paper size and orientation** section opens the **Edit paper list** dialog box, in which it is possible to disable the unused formats, enable additional ones or delete paper formats that belong to the custom formats list.

The dialog box contains the list of all available paper formats that can be included in the list.

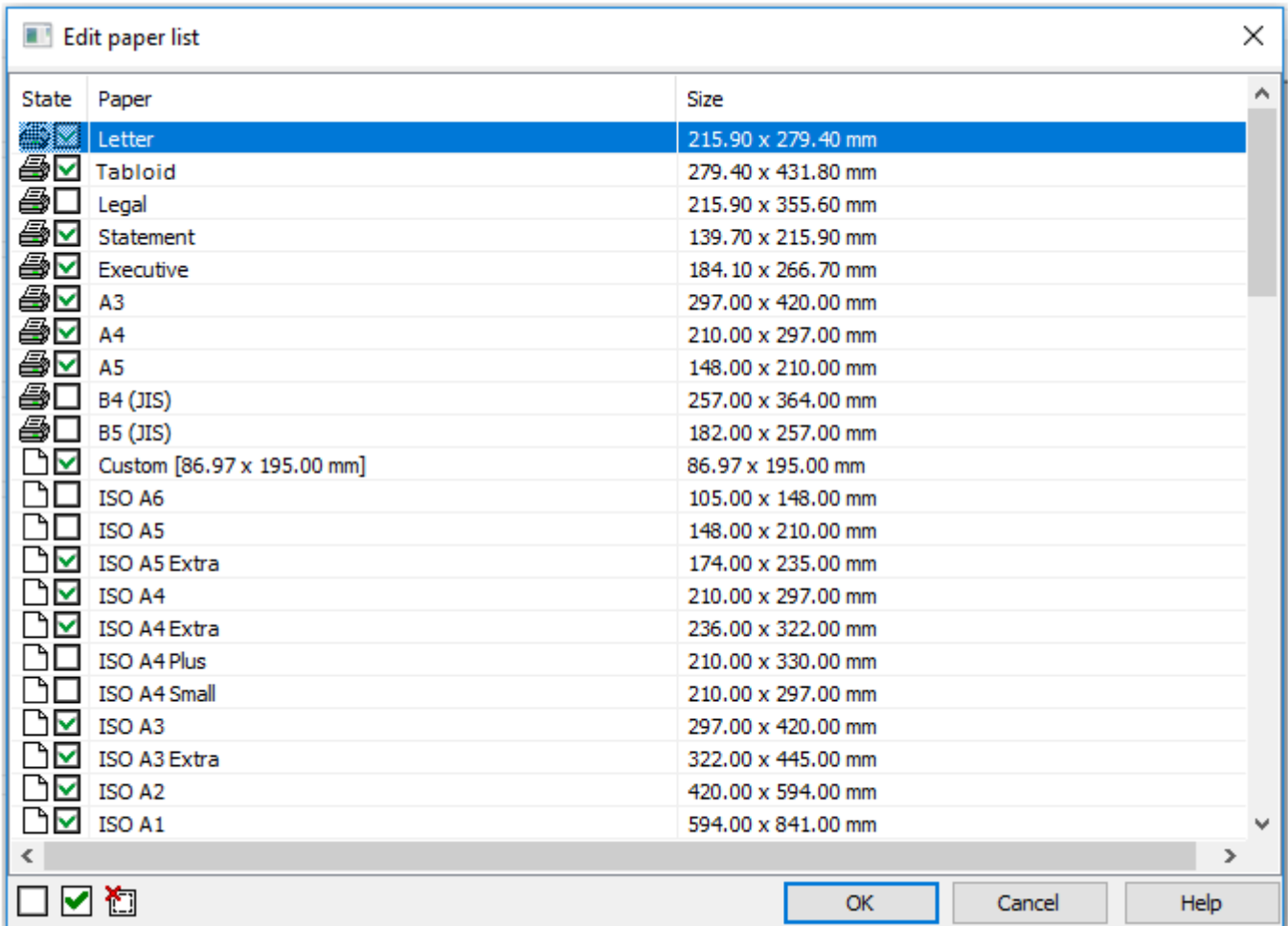

### Options:

- State**
- Paper format belongs to the list of formats of the selected plot device.
  - Paper format belongs to the list of custom formats nanoCAD.
  - Format is included in the list.
  - Format is deleted from the list.
- Paper** Names of standard and custom paper formats.
- Size** Sizes of standard and custom paper formats.

### To edit the list of paper formats:

1. Select the format in the dialog box.
2. Select/clear the checkbox  in the **State** column or use the dialog buttons:

- Turn off paper**
- Turn on paper**
- Delete custom paper**

**NOTE:** Paper formats that belong to the current plot device and are marked with cannot be deleted.

To edit the status or delete several formats at once use the multiple selection:

- While holding down **SHIFT** key, select all formats located between the first and the last left click.
- While holding down **CTRL** key, it is possible to add any format from the list by left click.

**ATTENTION!** Editing in the **Paper formats list editor** dialog box is synchronized with the **Papers** list of the **Options** dialog box (the **Tools** menu – **Options**). The custom formats are deleted simultaneously from all format lists.

## Plot Preview

The right part of **Page Setup** and **Plot** dialogs is the window for preview of the specified plot setups.

Change of plot setups is dynamically displayed in the preview window.

The preview window provides two options for displaying the specified plot area: schematic (simplified) and normal, in which the plot setting is displayed in the view it will be output to the plot device.

*Conventions in schematic (simplified) preview:*

*Dashed line* – the plot area boundaries for the selected plot device and specified paper format.

*Numbers* – size of the specified paper format and indentations to the plot boundary. Indentations from the paper edge to the plot boundaries depend on the selected plot device.

*Blue hatch and letter A* – location and orientation of the specified plot area on the page.

*Red line* – warning that the specified plot area is outside the plot margins.

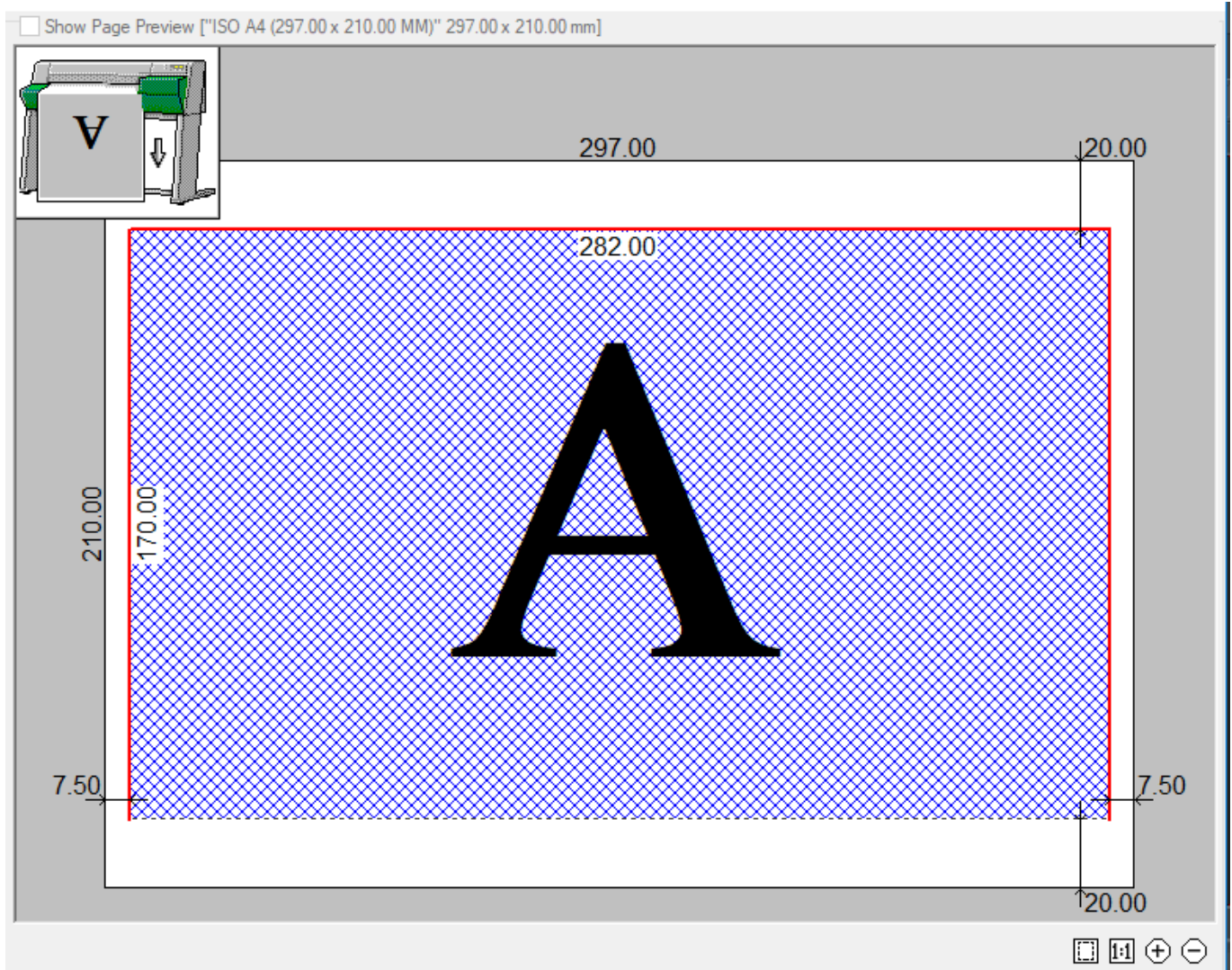

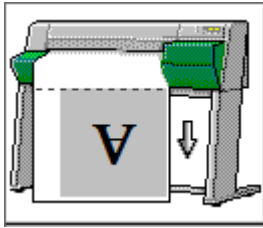

The icon with printer image (in schematic symbol in preview window) that displays the positioning of the specified plot area on a paper page. The arrow shows the direction of paper exit at plotting.

Switching of schematic symbol in the preview window to a normal one and vice versa is carried out by selecting/removing **Preview** checkbox, located above the preview window; the information about the specified paper format is also displayed here:

Show Page Preview ["ISO A3 (420.00 x 297.00 mm) (Landscape)" 420.00 x 297.00 mm]

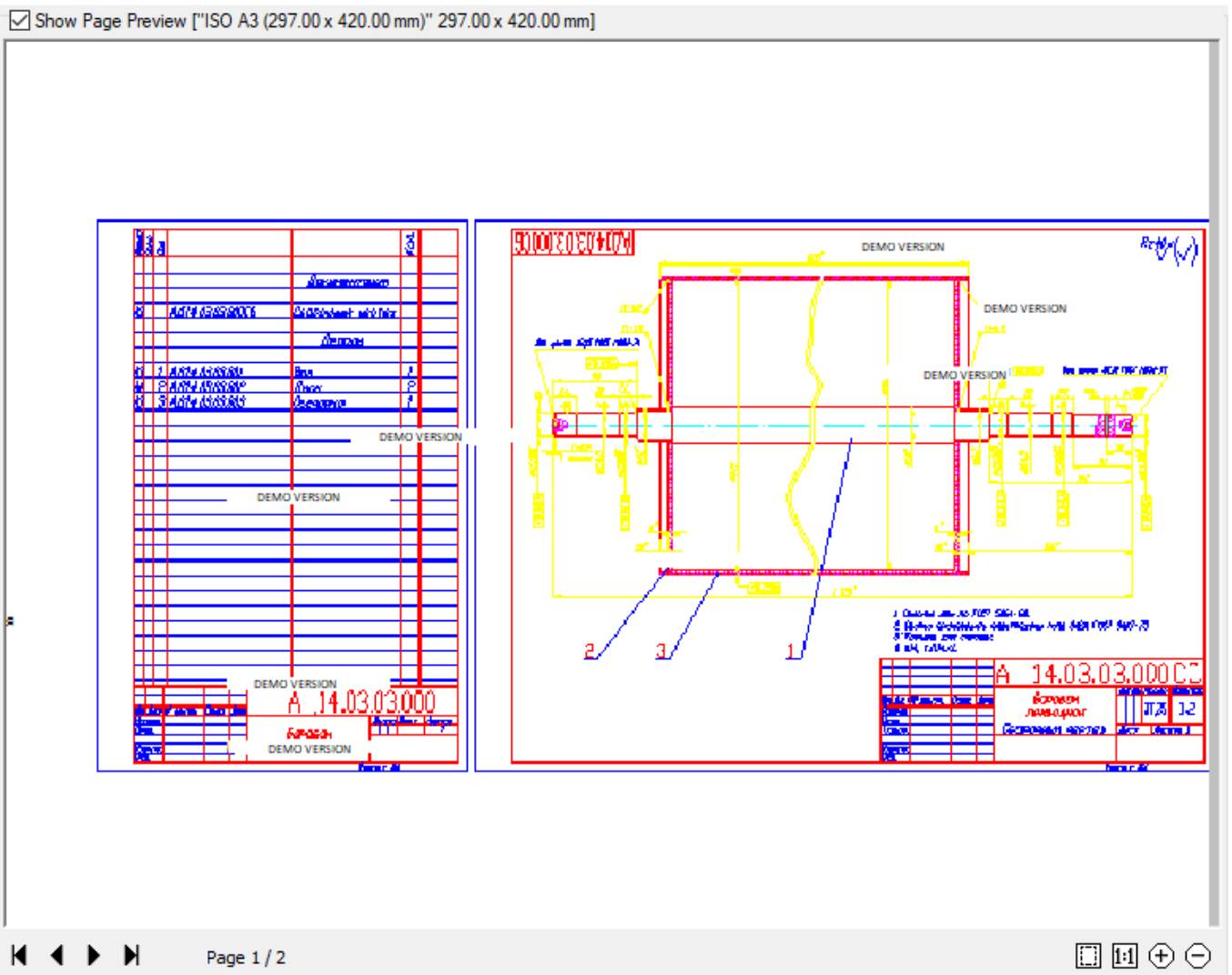

Show Page Preview ["ISO A3 (297.00 x 420.00 mm)" 297.00 x 420.00 mm]



The screenshot displays a technical drawing layout on an ISO A3 page. On the left, there is a table with columns for '№', 'Имя', 'Исполнитель', and 'Дата'. The main area contains a schematic diagram with various components and dimensions. A title block on the right includes the drawing number 'A 14.03.03.000' and other project information. The interface features navigation buttons (back, forward, home, search) and a 'Page 1/2' indicator at the bottom.

**ATTENTION!** For a layout that does not have an assigned plotter, preview is not available.

#### Options of the preview dialog box (for normal view):

- 
**Zoom all** Button to display the whole specified plot area in the preview window.
- 
**Zoom 1:1** Button to display the specified plot area at a scale of 1:1.
- 
**Zoom in** Button to zoom in the image in the preview window.





 **Zoom out** Button to zoom out the image in the preview window.

*Additional options displayed for a multipage plot:*

 **First page** Button to display the first page of a plot set in the preview window.

 **Previous page** Button to display the previous page of a plot set in the preview window.

 **Next page** Button to display the next page of a plot set in the preview window.



 **Last page** Button to display the last page of a plot set in the preview window.



 **Page 5 / 12** Displays the number of the page viewed in the preview window, and the total number of pages of the plot set.



It is possible to zoom and pan an image in the preview window by a mouse after clicking inside the window:

- *to zoom* an image – rotate the mouse wheel.
- *to pan* an image – move the mouse with the left or right button pressed and held, as well as with a mouse wheel.

A separate **Plot Preview** dialog box with normal view of the plot set can be opened from:

 Ribbon: **Output – Plot >**  **Preview**

 Menu: **File –**  **Preview...**

 Toolbar: **Main –** 

 Hot keys: **CTRL+F2**

 Command line: **PREVIEW**

In the **Batch plot** dialog box, the **Plot preview** is opened by **Preview** button.

The possibility of quick plot of the content using the **Plot** button is added to the parameters of the preview window in the **Plot Preview** dialog box:

Number of copies:   Setting the number of copies to print.





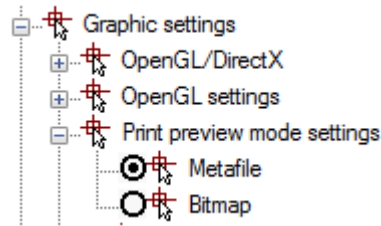

 **Plot** The button to plot.

When plotting individual files (with rich graphics, a large number of viewports, etc.) the message "*Not enough memory to create preview*" can appear in the preview window. In this case it is necessary to change the setting in the **Print preview mode settings** section (**Graphic settings** item of the **Options** dialog box).

By default, the **Metafile (WMF)** parameter is set:



## Plot Style Manager

-  Ribbon: **Output – Plot >**  **Plot Style Manager**
-  Menu: **File –**  **Plot Style Manager...**
-  Toolbar: **Main –** 
-  Command line: **PLOTSTYLEMANAGER**

A plot style is the same object property as a line type or color, and allows modifying an object's view at plotting. Plot styles can be assigned to both individual objects and layers. Assigning of a plot style to objects or layers allows replacing their color, type and lineweight with other values that are not displayed on the screen, but appear only when plotted. One and the same drawing can be printed in different ways, for example, in color or monochrome, by assigning various plot styles to it.

Sheet content is displayed according to the plot style applied to that sheet. For example, if the print style is set to monochrome, the sheet content is also displayed in black and white.

Plot styles are determined in two types of tables: *color-dependent* and *named*.

*Color-dependent plot style tables* are based on objects colors and are stored in files of \*.ctb extension. When selecting color-dependent style for plotting, all objects that share the same color will be plotted with the same parameters, for example, the same lineweight or the same line type.

*Named plot style tables* are stored in files of \*.stb extension and are assigned to the objects regardless of their color. When using named style, the objects that share the same color can be plotted with different parameters assigned to each object.

By default, plot style tables (files of \*.ctb and \*.stb extension) are located in the folder `C:\Users\user_name\AppData\Roaming\Nanosoft AS\nanoCAD X.X\PlotStyles`.

Plot style editor allows you to add, delete, copy, rename and edit the plot style tables. First the **Plot style** dialog box is opened, where the type of plot style table is selected (**Color-dependent plot style table** (\*.ctb) or **Named plot style table** (\*.stb)):

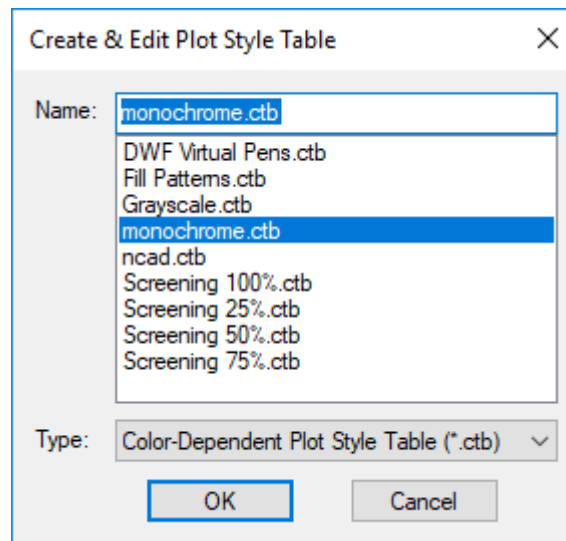

After clicking **OK** button the **Plot style table editor** dialog box is opened:

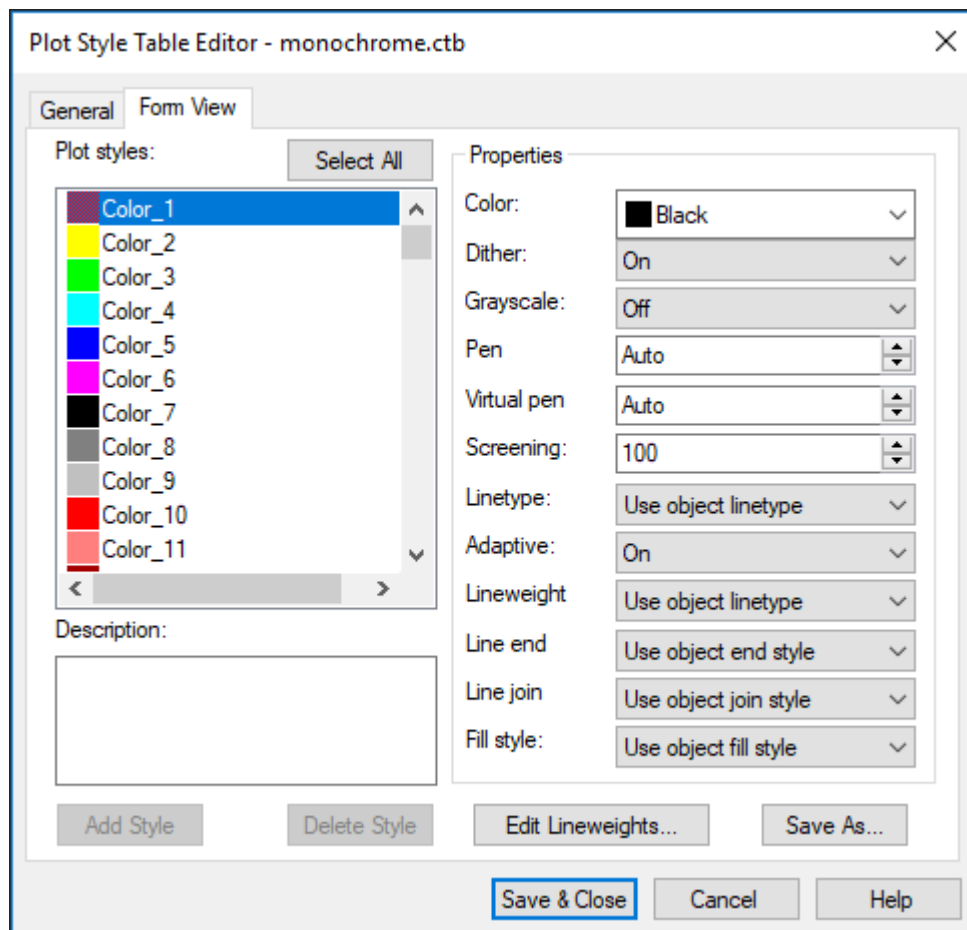

The **General** tab contains a description of the plot style table and general information about the file.

In the **Form View** tab, you select the plot style and modify its settings.

The **Edit Lineweights** button opens the **Edit Lineweights** dialog box:

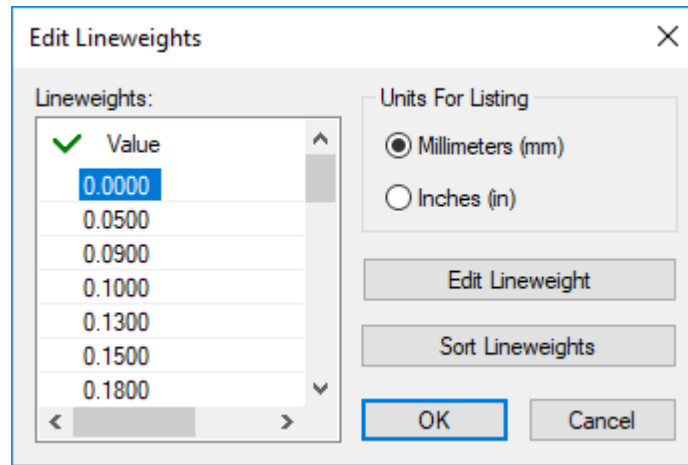



The plot style editor can also be opened by the  button from the **Page Setup** dialog box.

## Plot

 Ribbon: **Output – Plot** >  **Plot**

 Menu: **File** –  **Plot...**

 Toolbar: **Main** – 

 Hot keys: **CTRL**+**P**

 Command line: **DWFOUT, PLOT**

The command opens the **Plot** dialog box that differs from the **Page Setup** dialog box only in one section – **Page setup** – and the **Plot** button instead of **OK** button, as well as possibility to set the number of copies to be plotted:

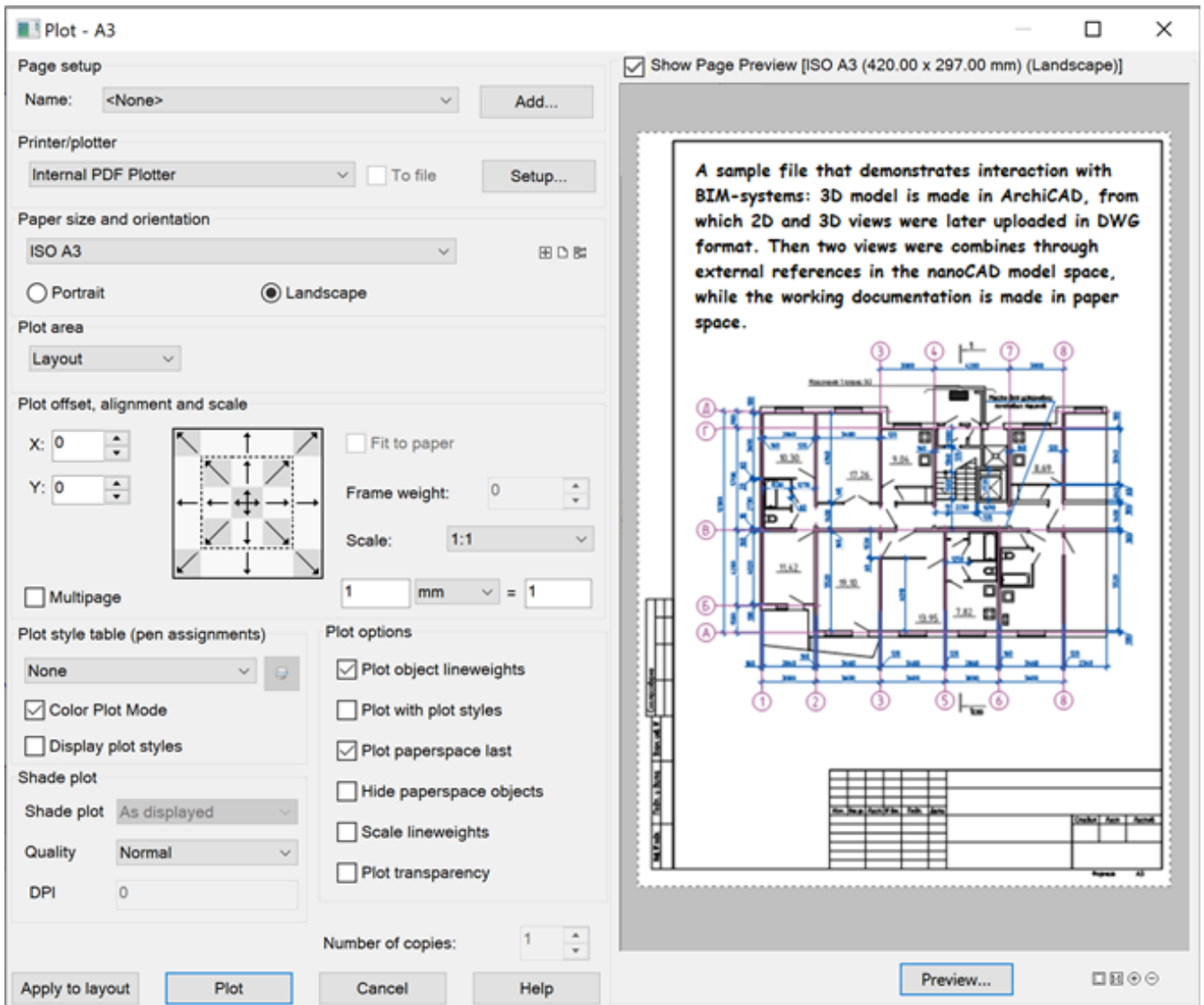

If there is no plotting device (plotter/pc3) specified in the document, the [Internal PDF Plotter](#) will be used. In this case, whenever possible, the format dimensions and orientation specified in the pc3 file or document are preserved. The [Internal PDF Plotter](#) will select the format that exactly matches the size specified in the document or pc3, or the next larger one from the list of formats available for that plotter. The list of available formats is configured in the [Options](#) dialog and in the [Paper Format List Editor](#).

### Options:

#### Page setup

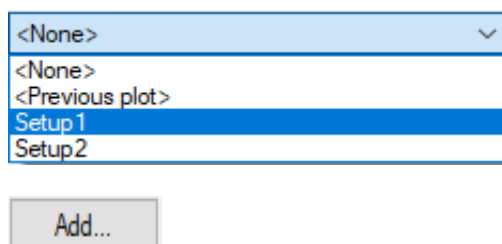

Drop-down list that displays the page setups available in the document.

After the first document plot the **<Previous Plot>** option becomes available in the list; it stores the settings of the last plot set.

Button to open the **New Plot Set** dialog box to specify the name for a new page setup and add it to the document's page setups.

**Number of copies:** Sets the number of copies to be plotted.

Description of other options – see "Page Setup" section.

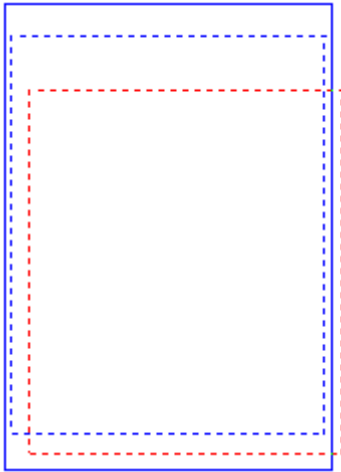

When setting the plot area in the layout space, the screen displays:

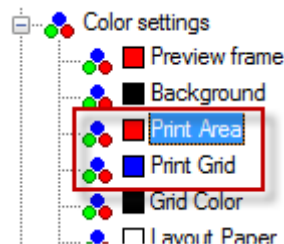

- size and orientation of the paper format selected to plot as a frame displayed by a solid blue line;
- real plot area for the specified printer and selected paper format as a frame displayed by a dashed blue line;
- specified plot area of the document as a frame displayed by a dashed red line.

The frame colors specified by default can be changed in the **Color settings** section of the **Options** dialog box (the **Tools** menu – **Options**):



**NOTE:** When specifying plot areas in the model space, the screen displays only the specified plot area as a frame displayed by a dashed red line.

### To set several plot areas:

1. In the drop-down list of the **Plot area** section, select the **Window** option.
2. After closing the dialog box, specify the first plot area on the screen by setting two opposite rectangle corners.
3. In the newly opened **Plot** dialog box click  **Add window print area** button and specify the second plot area.
4. Repeat the process of specifying for other plot areas.
5. To cancel the last specified plot area, click the  **Delete last print area** button. At repeated clicking this button, the previous plot area will be deleted and so on.

**ATTENTION!** When clicking the **Delete last print area** button, the **Plot** dialog box is not closed.

**NOTE:** To cancel all specified plot areas and specify a new plot area, click the **New window print area** button.

**NOTE:** It is recommended to specify the plot areas of the same format. If, for example, select *A4 Portrait* paper size and specify several plot areas of *A4* format, and then select *A3 Landscape* paper size and additionally set several plot areas of *A3* format, then all specified areas (including *A4*) will be printed on the *A3 Landscape* paper.

### For multipage plot:

1. Select a printer.
2. Specify the paper size and orientation.
3. Turn off the **Fit to paper** option, if it is on.
4. Specify the plot scale.
5. Turn on the **Multipage** option.
6. Specify the plot area.
7. If necessary, set the plot area offset or turn on the **Center the plot** option.

The normal preview window displays the page selected for preview, its number and total number of pages the selected plot area was paginated (Page 1/15):

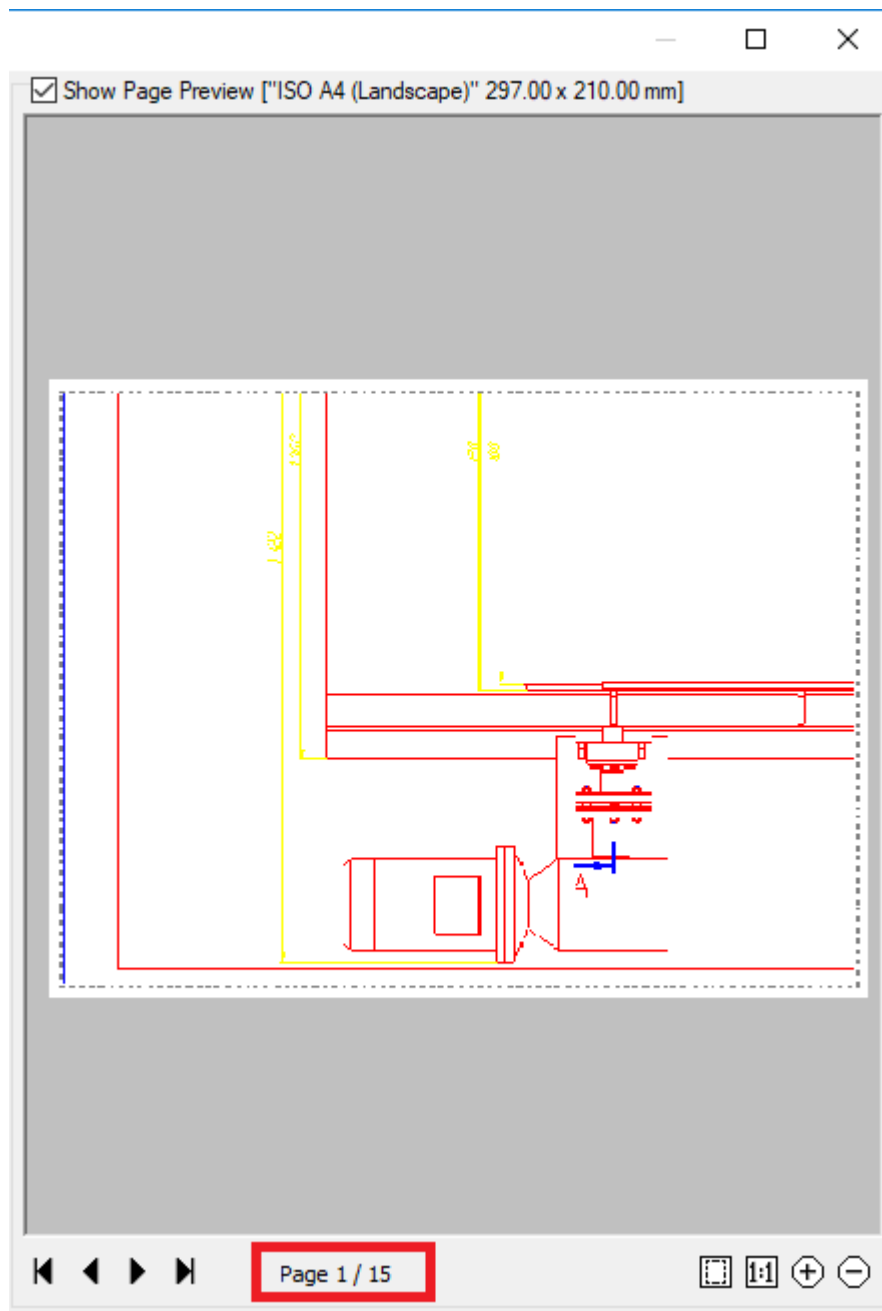



The multipage plot is useful to print large formats (A0, A1, etc.) on printers that do not support a plot of these formats.

## Batch Plot

 **NanoCAD button – Plot >**  **Batch Plot**

 **Menu: File –**  **Batch plot...**

 **Toolbar: Main –** 

 **Command line: PUBLISH**

The command allows you to create and send to print the list of drawing sheets from one or several files both from model space and from layout space. The simultaneous plot of sheets from model space and from layout space is also possible.

For each sheet in a dialog it is possible to specify the page setups, including that different printers can be assigned to different sheets. There is a possibility to sort sheets in the list, add and delete sheets from the list. Having preliminary selected several sheets using **CTRL** and **SHIFT** keys, you can delete entire groups of sheets, move them up and down the list, set sheet parameters for them. The formed sheets list (plot set) can be stored for further use.

The **Multi-sheet job** option allows you to place sheet list in one or more files, for example, when creating \*.pdf-files using virtual printers. The order of the sheets in the \*.pdf-file corresponds to the order of the sheets in the list.

After starting the command, the **Publish** dialog box opens:

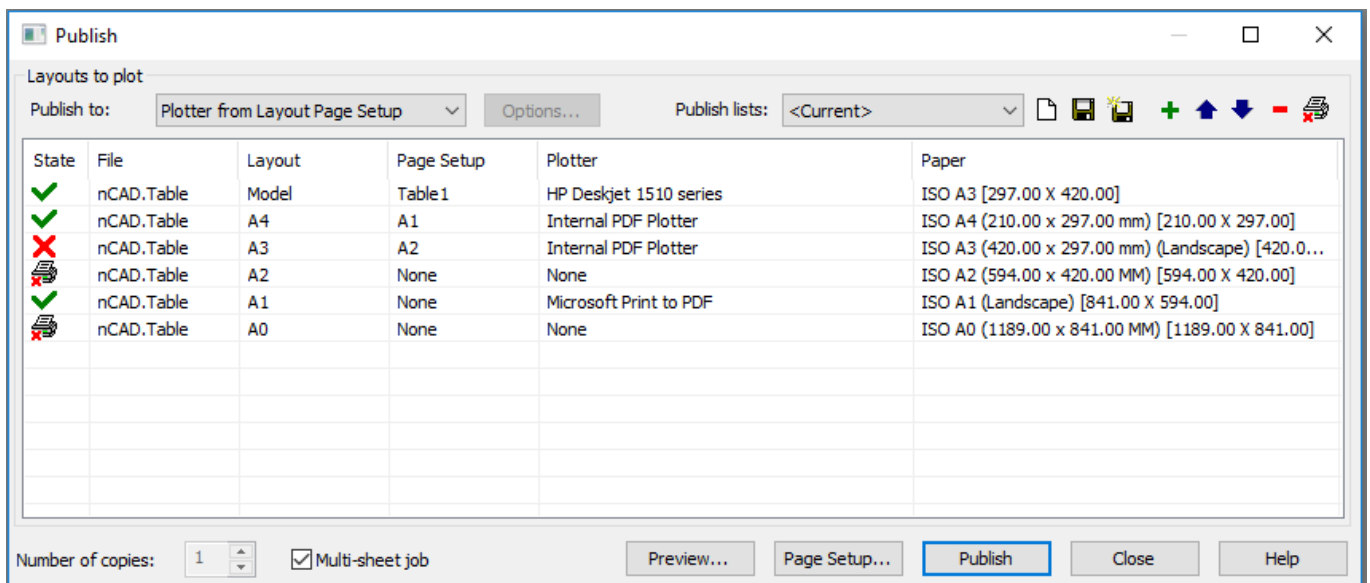

### Options:

#### Plot to:

Selects a plot device to output the plot result (plotter, printer, PDF-printer, etc.).

The selected **Plotter assigned in page setups** position ensures plotting with use of plot devices assigned in the page setups for each drawing.

For batch plot of all data on a particular device, it should be selected in the list. At that the paper size closest to that specified in the page setup is selected automatically.

**ATTENTION!** In automatic paper size selection, the correct positioning of the plot area and sheet position may be disturbed.



**Setup** Button to open the dialog box to change the current settings of the selected plot device.  
The view of opened dialog box and setting parameters are determined by the driver of the current plot device.

**ATTENTION!** When selecting a single plot device for all sheets in the list, the paper size specified in the device settings is ignored.

**Publish lists:** Drop-down list containing the named publish lists available to plot. By default (if there are no publish lists saved by the user) two lists are displayed:



- **Current** – List of all layouts available in the opened documents.
- **Last** – Last layouts list sent to plot.

**Number of copies:** Specifies the number of copies to publish.

**Multi-sheet job** Turns on/off the mode to plot sheets to the file, for example, when plotting on a virtual printer.  
The sheets plot is carried out in the order specified in the dialog box. If the same plotter is assigned to all sheets, all sheets will be placed in one file.  
When assigning different plotters for different sheets, the plot is carried out to separate files for each plotter. When changing the plotter, a new file is created.  
For example, if in the dialog box *Plotter 1* is assigned to first sheets, *Plotter 2* to several next sheets, and *Plotter 1* for the rest, then 3 files will be created – two separate files for *Plotter 1* and one file for *Plotter 2*.

### Columns

**State** Column to display the plot status:

-  - Print sheet.
-  - Don't print sheet.
-  - The plot is forbidden (in case of incorrect plot settings, for example, plotter is not assigned).

Left double click on the column switches the status from **Plot** to **Not plot**.

**File** Column to display the file name.

**Layout** Column to display the name of the layout tab in layout space. For the model space the **Model** value is displayed.

**Page setup** Column to display the named page setup assigned to the sheet. If the sheet does not have an assigned page setup, the value **None** is displayed.

In the drop-down list, you can select any other set of parameters present in the document and available for this layout, or import it from an external file. You can import layout presets from drawing files (\*.dwg), drawing template files (\*.dwt), graphics interchange format files (\*.dxf), CAD standards files (\*.dws).

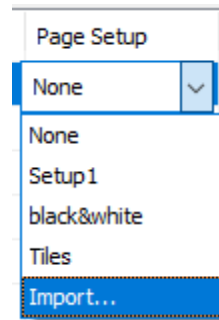

Using multiple selection (**CTRL** and **SHIFT** keys), you can assign a page setup to multiple pages at once. To do this, select several layouts, and in one of them specify the desired set of layout options. This set will be assigned to all selected layouts.

**Plotter**

Column to display the name of plotter assigned to the sheet. If the sheet has no assigned plotter, the value **None** is displayed.

**Paper**

Column to display size and orientation of the selected paper.

Left double click on the column names separator automatically changes the columns width.

To sort alphabetically by a specific column (parameter), click on the column heading.

Please note that when sorting the list by file name, layout names are displayed not in ascending or descending order, but in the order in which they are located in their files.

To sort through the sheets in alphabetical order, click on the header of the **Layout** column.

Layouts to plot			
Publish to: Plotter from Layout Page Setup			
State	File	Layout	Page Setu
	Untitled0	A1	None
	Untitled0	A2	None
	Untitled0	A3	None
	Untitled0	A4	None
	Untitled0	Model	None
	Untitled9	Layout9	None
	Untitled9	Layout10	None
	Untitled9	Layout11	None
	Untitled9	Layout19	None
	Untitled9	Layout20	None
	Untitled9	Layout21	None
	Untitled9	Model	None
	Untitled10	Layout9	None
	Untitled10	Layout10	None
	Untitled10	Layout11	None

Layouts to plot			
Publish to: Plotter from Layout Page Setup			
State	File	Layout	Page Set
	Untitled0	A1	None
	Untitled0	A2	None
	Untitled0	A3	None
	Untitled0	A4	None
	Untitled9	Layout9	None
	Untitled10	Layout9	None
	Untitled9	Layout10	None
	Untitled10	Layout10	None
	Untitled9	Layout11	None
	Untitled10	Layout11	None
	Untitled10	Layout12	None
	Untitled9	Layout19	None
	Untitled9	Layout20	None
	Untitled9	Layout21	None
	Untitled0	Model	None

## Buttons



### Current document publish list

Creates the publish list only from the current document.



### New publish list

Deletes all layouts from the dialog list to create a new publish list.



### Save publish list

Saves the publish list.

Click this button to open the **Save publish list as** dialog box:

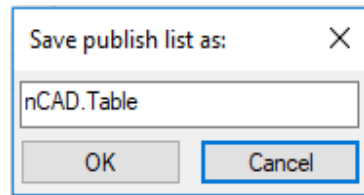

which proposes the *List* name by default.

It is possible to set the user name list instead of that proposed by default.

After clicking **OK** button the named list will be saved in the folder:  
*C:\Users\User\_name\AppData\Roaming\Nanosoft AS\nanoCAD 24.0\PlotConfigs\*

The named lists are saved in files with \*.plst extension.



### Save publish list as

Saves the publish lists with a new name.

Clicking this button also opens the **Save publish list as** dialog box, which proposes by default the *List* name as a new publish list name.

If a new list name coincides with the already existing one, after clicking **OK** button the following message is displayed:

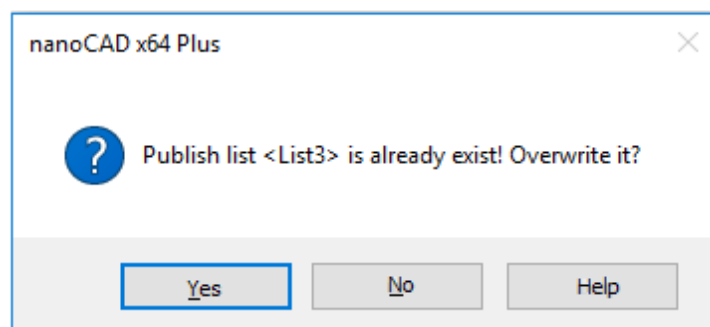

### Add page to plot

Adds a new page to the list.

It is possible to select page for adding to the list only from the documents opened in the editor.

Clicking the button opens the following dialog:

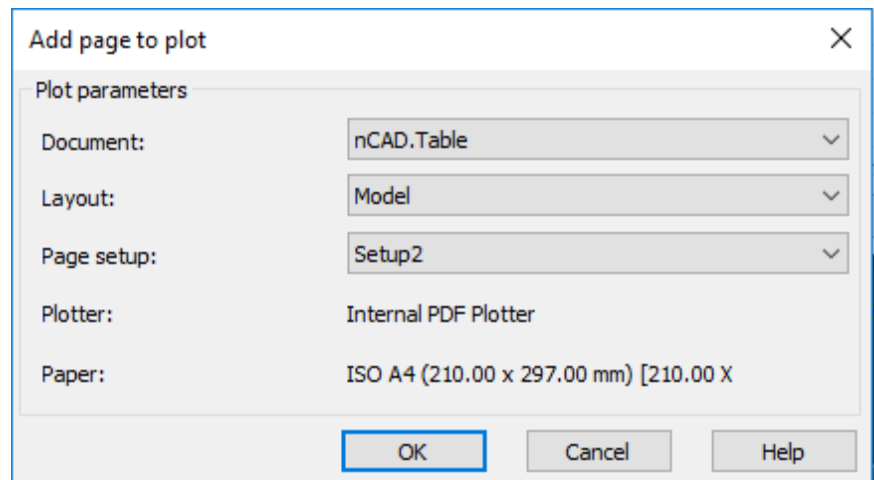

In the drop-down lists of the **Add page to plot** dialog box it is possible to select:

- document (if several documents are opened simultaneously) that contains the page to be added to plot list (**Document:**);
- layout from the selected document to add it to the list (**Layout:**);
- a named set of parameters list, if it is available in the document (**Page setup:**).



**Move up**

Moves the sheet selected in the list up one position.



**Move down**

Moves the sheet selected in the list down one position.



**Remove from the list**

Deletes the selected sheet from the list.

It is also possible to delete the sheet selected in the list by **DEL** key.



Deletes all elements with unspecified plotter from the list.

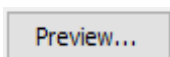

Button to open the **Plot preview** dialog box.

The preview of plot results is possible only for the selected sheet in the list. When printing from the preview mode, only the viewable sheet will be printed.

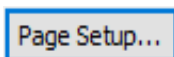

Button to open the **Page Setup** dialog box to specify the plot options.

Left double-click on any column of the selected sheet, except the **State** column, will also open the **Page Setup** dialog box.

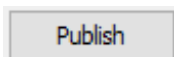

Button to start publishing. All sheets with the specified state allowing printed output, will be printed.

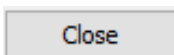

Button to close the dialog box.

### **To create named publish lists to plot (plot set):**

1. Open one or more documents, the layouts of which it is necessary to plot.
2. Start the **Batch plot** command.
3. When opening the **Publish** dialog box, the list of all layout tabs available in all opened documents is formed automatically. The following order of the layouts in the dialog box is set by default:

- the first displayed in the list is a document from which the **Batch Plot** command was started, it is followed by documents in order of their tabs in the graphic editor window (from left to right);
- the first displayed in the document is the **Model** tab, followed by **Layout1**, **Layout2**, **A4**, **A3** tabs, etc.
  4. To edit the list:
- to remove layouts unnecessary to plot, select the sheet in the list by left click and click **Remove from list** button or press **DEL**.
- to change the order of layouts, use the **Move up** and the **Move down** buttons.
  5. To specify the plot settings for each page, click the **Page Setup** button (left double click on any selected layout column, except the **State** column, also opens the **Page Setup** dialog box).

**NOTE:** Use of previously created named sets of page setup in this case will allow you to reduce the time of parameters settings.

6. Click the **Save publish list** button.
7. Enter the list name in the **Save publish list** dialog box.
8. Click **OK** button to save the list.
9. Click the **Close** button to close the **Publish** dialog box.

**NOTE:** When saving a plot setting for each layout, name and location of the file it belongs to are stored in the list. Selection of a named list of layouts to plot in any opened file and left double click on any column of selected layout, except the **State** column (or clicking **Page Setup** button) automatically loads the file to which this layout belongs, provided that the path to file has not changed.

#### **To edit the publish list to plot:**



1. Open the document.
2. Start the **Batch plot** command.
3. In the **Publish** dialog box select the necessary list in the drop-down **Publish lists** list.
4. Make necessary changes in the list (change the layout composition or page setups).
5. Click the **Save publish list** button.
6. Click the **Close** button to close the **Publish** dialog box.

#### **To rename the publish list to plot:**

1. Open the document.
2. Start the **Batch plot** command.
3. In the **Publish** dialog box select the necessary list in the drop-down **Publish lists** list.
4. Make necessary changes in the list (change the layouts composition or page setups).
5. Click the **Save publish list as** button.
6. Enter a new list name.
7. Click **OK** button to save the renamed list.
8. Click the **Close** button to close the **Publish** dialog box.

## Features of the Batch Plot from the Model Space

### For the batch plot from the model space:

1. Start the **Page Setup Manager**.
2. In the opened dialog box, click the **New** button.
3. In the **New Plot Set** dialog box, enter the set name, for example, *A4 Portrait*.
4. Click **OK** button.
5. In the opened **Page Setup** dialog box, select printer, paper size - *A4*, paper orientation - *Portrait*, set the plot scale and other plot options.
6. Set by the **Window** the 1-st plot area of A4 format, then the 2-nd and all other plot areas of A4 format (  **Add window print area** button). To delete the last specified plot area, use  **Delete last print area** button. The **Preview** button allows you to see a preview plot result of the selected areas. The preview option can be used at any stage of setting plot areas.
7. After setting the last plot area of A4 format, to finish the procedure of creating page setup set of *A4 Portrait*, click **OK** button in the **Page Setup** dialog box.

**ATTENTION!** When forming the name set of page setups for batch plot from the model space, it is necessary to include all areas of corresponding format to be printed.

8. Click the **New** button to create the next page setup (for example, *A3 Landscape*) in the same way.
9. Repeat the procedure to form all the other plot sets (for example, to create sets *A2 Portrait*, *A1 Landscape*, etc.).
10. After specifying the last plot set, click the **Close** button in the **Page Setup Manager**.

After creating all named sets of page setups of the model space, it is possible to start the batch plot.

### For the batch plot of the created name sets of pages setup:

1. Start the **Batch Plot** command.
2. In the **Publish** dialog box, click the **New publish list** button to clear the current list.
3. Click the **Add page to plot** button.
4. In the opened **Add page to plot** dialog box:
  - in the drop-down **Document** list select a document (if the batch plot is performed for multiple documents at once);
  - in the **Layout** list select **Model** parameter (displayed by default when plotting from model space);
  - in the **Page setup** list select the *A4 Portrait* parameters set.
5. Click **OK** to add selected name set in the plot list.
6. Click the **Add page to plot** button to add the next set (for example, *A3 Landscape*).
7. Add similarly the rest parameter sets (for example, *A2 Portrait*, *A1 Landscape* etc.).

- To send the formed set to plot, click the **Publish** button.

## Internal PDF-Plotter

In the nanoCAD there is a possibility to transform and print the drawings to a PDF file (Adobe® Portable Document Format) by using the internal PDF-plotter. When printing, it is possible to create both several single-page PDF files and one multi-page file.

### To print in PDF file:

- Open the **Plot** dialog box.
- In the drop-down list of the **Printer/Plotter** section select **Internal PDF-plotter**.
- Click the **Setup** button.
- Perform the necessary settings in the opened **Internal PDF-plotter** dialog box:

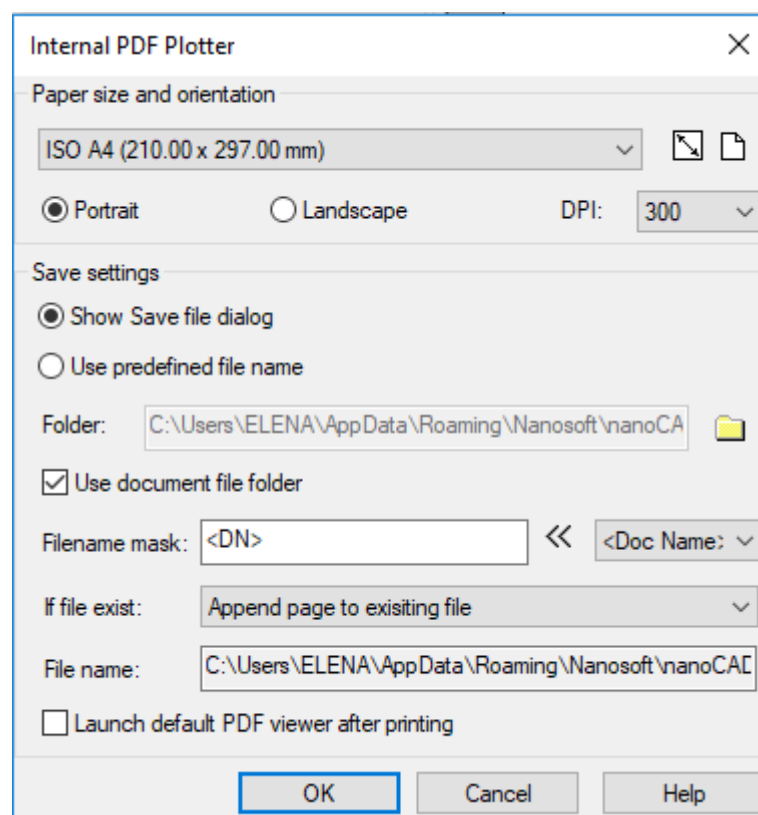

### Options:

#### Paper size and orientation

ISO A4 (210.00 x 297.00 mm) ▾

Drop-down list to select paper formats.



**Modify paper format**

Edits the predefined paper format.  
Button to open the [Modify paper format](#) dialog box.



**Add paper format**

Adds a new paper format.  
Button to open the [Add paper format](#) dialog box.

**Portrait**

Sets the portrait paper orientation.

**Landscape**

Sets the landscape paper orientation.

**DPI**

Sets the resolution to save in the PDF file.

*Save settings*

**Show save file dialog**

Opens the standard dialog box to specify the name and storage location of pdf-file after printing.

**Use predefined file name**

Turns on the mode of saving pdf-file with document file name (pdf-file name and its storage path are displayed in the **File name** field).

**Folder:**

Displays the path to the folder of pdf-file storage.  
By default, it sets the folder that contains the original document. It is possible to select another folder for storing pdf-file by turning off **Use the document file folder** checkbox and clicking  button.

**Use document file folder**

Turns on the mode of the pdf-file storage in the original document folder.

**Filename mask:**

Sets the template for the pdf-file name.  
To the pdf-file name entered in this field, the name of original document, layout name, user name, etc. separated from file name and from each other with underscore symbol ( \_ ) can be added automatically with help of variables.

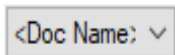

Drop-down list of variables to form the pdf-file name template.

The following variables are available:

- **<Doc name>** – The <DN> variable adds the name of the original document to the name of created pdf-file.
- **<Layout name>** – The <LN> variable adds the layout name of the original document to the name of created pdf-file.
- **<User name>** – The <UN> variable adds the user name to the name of created pdf-file.
- **<Time>** – The <T> variable adds the time of file creation to the name of created pdf-file.
- **<Date>** – The <D> variable adds the date of file creation to the name of created pdf-file.
- **<Counter1>** – The <C1> variable adds the number (index) in the format of 1, 2, 3, etc. to the name of created pdf-file.
- **<Counter01>** – The <C2> variable adds the number (index) in the format 01, 02, 03, etc. to the name of created pdf-file.
- **<Counter001>** – The <C3> variable adds the number (index) in the format 001, 002, 003, etc. to the name of created pdf-file.
- **<Counter0001>** – The <C4> variable adds the number (index) in the format 0001, 0002, 0003, etc. to the name of created pdf-file.
- **<Counter00001>** – The <C5> variable adds the number (index) in the format 00001, 00002, 00003, etc. to the name of created pdf-file.
- **<Counter000001>** – The <C6> variable adds the



number (index) in the format 000001, 000002, 000003, etc. to the name of created pdf-file.

- **<Separator>** – The <\_> variable adds the underscore symbol ( \_ ) to the name of created pdf-file.

All variables, when added to the existing file name template, are automatically separated with underscore symbol ( \_ ). If necessary, the underscore symbol (separator) can be inserted in the template manually by selecting in the drop-down list.

**If file exists:**

Drop-down list to set options, when saving pdf-file with the name of already existing file.

The following parameters are available:

- **Append page to existing file** – Appends the PDF pages of the document to the pages of already existing pdf-file.
- **Show warning dialog** – When setting this option, after clicking **Plot** button, the **Specify action** dialog box opens:

The dialog box proposes the user to choose options to save pdf-file:

- overwrite the existing file (the **Overwrite** button);
- save in a new file with the name of an existing file, to which the number will be added automatically (the **Autonumbering** button);
- add the document pages to the pages of an existing pdf-file (the **Add page** button).
- **Always overwrite existing file** – Overwrites the contents of an existing pdf-file.
- **Auto numbering file name** – Saves a file with new name consisting of the name of an existing file and automatically added number (index).

**File name:**

Displays the path and specified name of the pdf-file.

**Launch default PDF viewer after printing**

Turns on/off the viewing in the installed software of PDF files viewing after the end of pdf-file printout.

**SHX text annotations**

When printing to PDF, it is possible to convert SHX texts to PDF comments. Such comments will be created at the locations of text objects with the SHX font. Comments contain the full text of these objects. This allows you to search the contents of SHX text in a PDF document.

To search for text in PDF comments, you need to activate the **Include comments option** in the Search settings of PDF viewer.

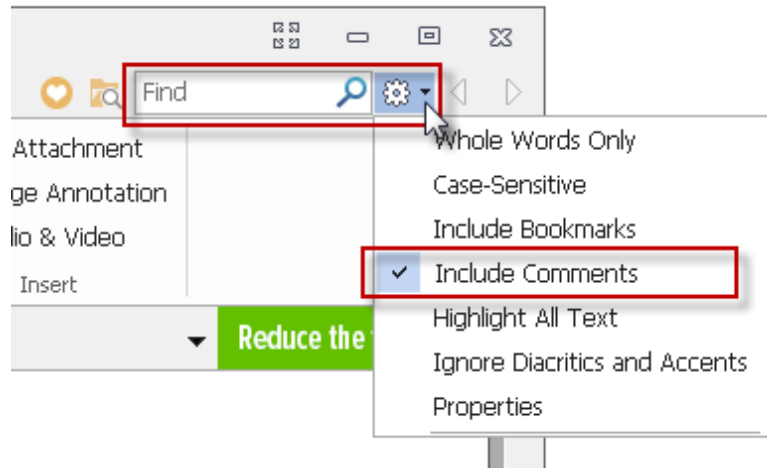

Comment creation can be disabled by the PDFSHX variable or with the **SHX text annotations** check box.

5. Click **OK** to close the **Internal PDF-printer** dialog.
6. Set the necessary parameters in the **Plot** dialog box: specify plot area, plot scale, etc.
7. To printout the document to PDF file, click the **Plot** button.

## EDS

---

Electronic digital signature (EDS) is a block of enciphered information added inside files or placed near files to prevent their changes and save information about their creator.

Adding EDS is called signing a file. Two variants of signing are realized:

- Creating internal EDS in the process of saving the file.
- Creating an external EDS file.

To digitally sign a file it is necessary to have a digital certificate issued by the independent certification center. You can also create a self-signed certificate using one of the programs.

Digital signature can be validated. It is important in joint work on projects and on receipt of executable file. You can verify the signature authenticity, name of organization or person who signed the file, etc.

### *Invalid digital signatures*

A digital signature can become invalid for the following reasons:

1. The file was modified after the digital signature was attached (renaming a file does not invalidate its digital signature).
2. The digital certificate was revoked by the certification center.

### *Reapply a Digital Signature to a Drawing file*

In some cases, you might need to make changes to a drawing file and then reapply your digital signature. In those cases, use WBLOCK command, specifying the entire drawing, and save it to a different file name for the sake of version control. Then apply your digital signature.

## *Creating Internal EDS*

The mechanism allows you to attach EDS to a file when it is saved.

First you should set EDS certificate;

1. in the current document open **Attach digital signatures** command DIGITALSIGN;

- in the opened dialog box check the red flag of the required certificate;

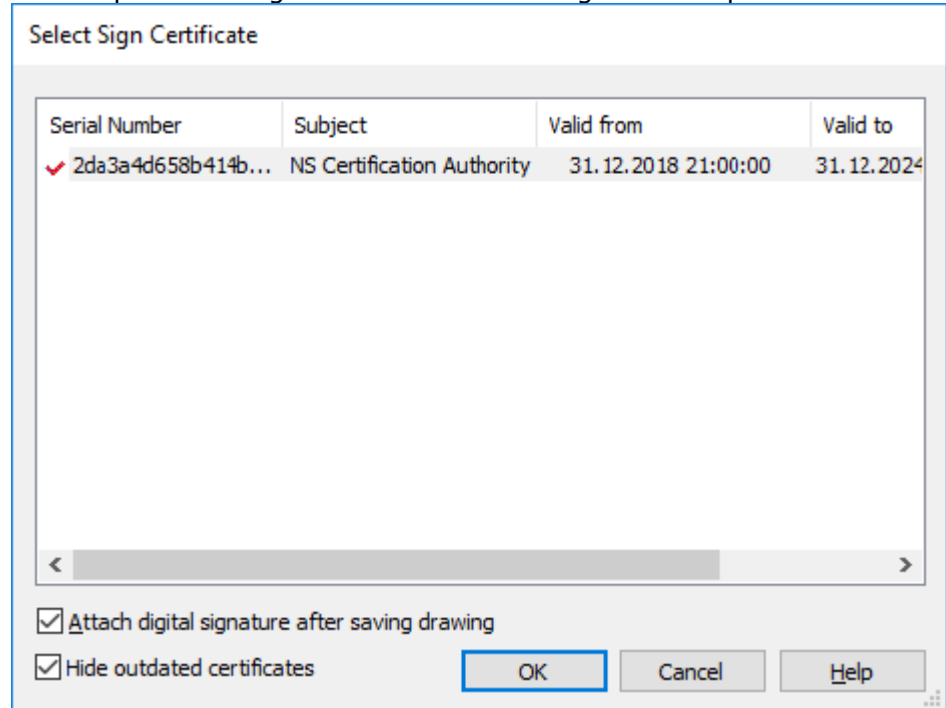

- check the flag **Attach digital signature after saving drawing**.

When saved, the signed file gets  sign.

**Validate digital signatures** command (SIGVALIDATE) allows you to verify validity of the file's electronic digital signature. The command shows in the command line information on the presence and attributes of EDS of the current file.

## Creating External EDS File

The mechanism allows you to create a file of electronic digital signature of the form `FileName.Format.sig` and sign files of any format.

First start **Specify digital signature certificate** command (SIGNCERTIFICATECONTROL) and check the flag of the required EDS certificate.

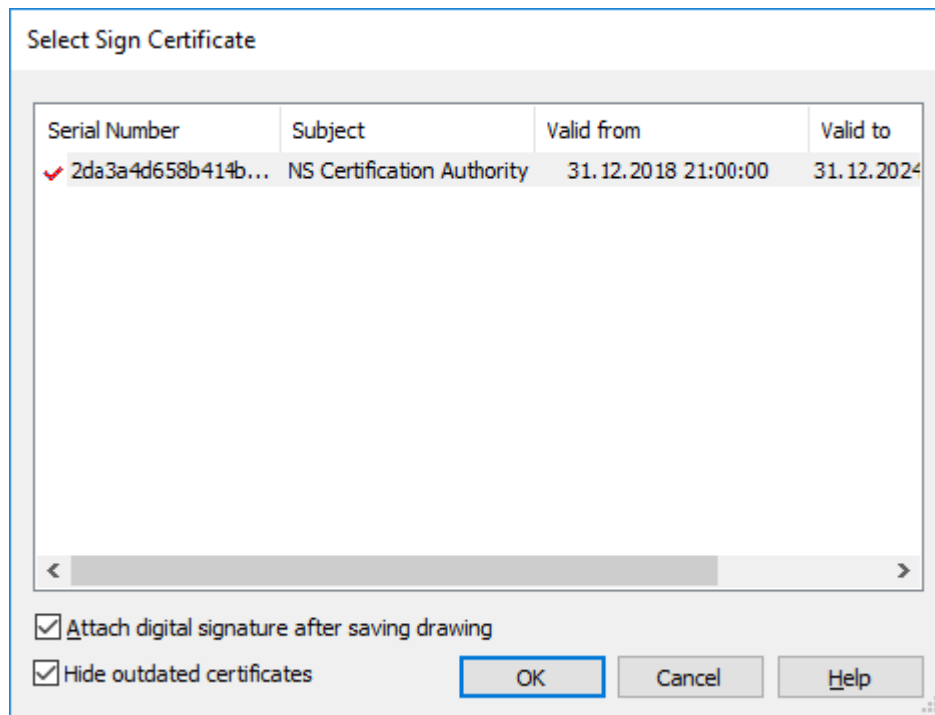

To create EDS file, use **Sign external file** command (SIGNFILE) and select the file to be signed. **Validate digital signature** command (VALIDATESIGN) allows you to verify whether the selected file corresponds to the digital signature file. First, specify the signed file `FileName.Format`, then EDS file `FileName.Format.sig`.

## SHEET SET

In nanoCAD system you can create a *sheet set* – conventional folders where layouts and named views of project drawings are collected and arranged. Using a sheet set, for example, it is convenient to plot, as the output process will include only project layouts needed at the moment, even if they belong to different drawing files. To work with sheet sets, use the **Sheet Set Manager**.

Sheet set data are saved in .dst file. There are two types of sheet sets: *set of layouts* (includes drawing layouts) and *set of views* (includes model named views).

**NOTE:** Including layout or view into a sheet set does not change their real position, they stay at the same places as before.

**ATTENTION!** It is not recommended to include the same layout into different sheet sets (you should better create another file with an xref to the main one).

### Create Sheet Set



nanoCAD button -  **New** >  **New Sheetset**



Menu: **File** -  **New Sheet Set...**



Drop-down list of the **Sheet Set Manager** functional bar: **New Sheet Set ...**



Command line: **NEWSHEETSET**

The **New Sheet Set** command is implemented as a wizard of four pages. Select creation mode on the first page: from scratch (with choosing the drawings to be included) or from the pattern of another sheet set.

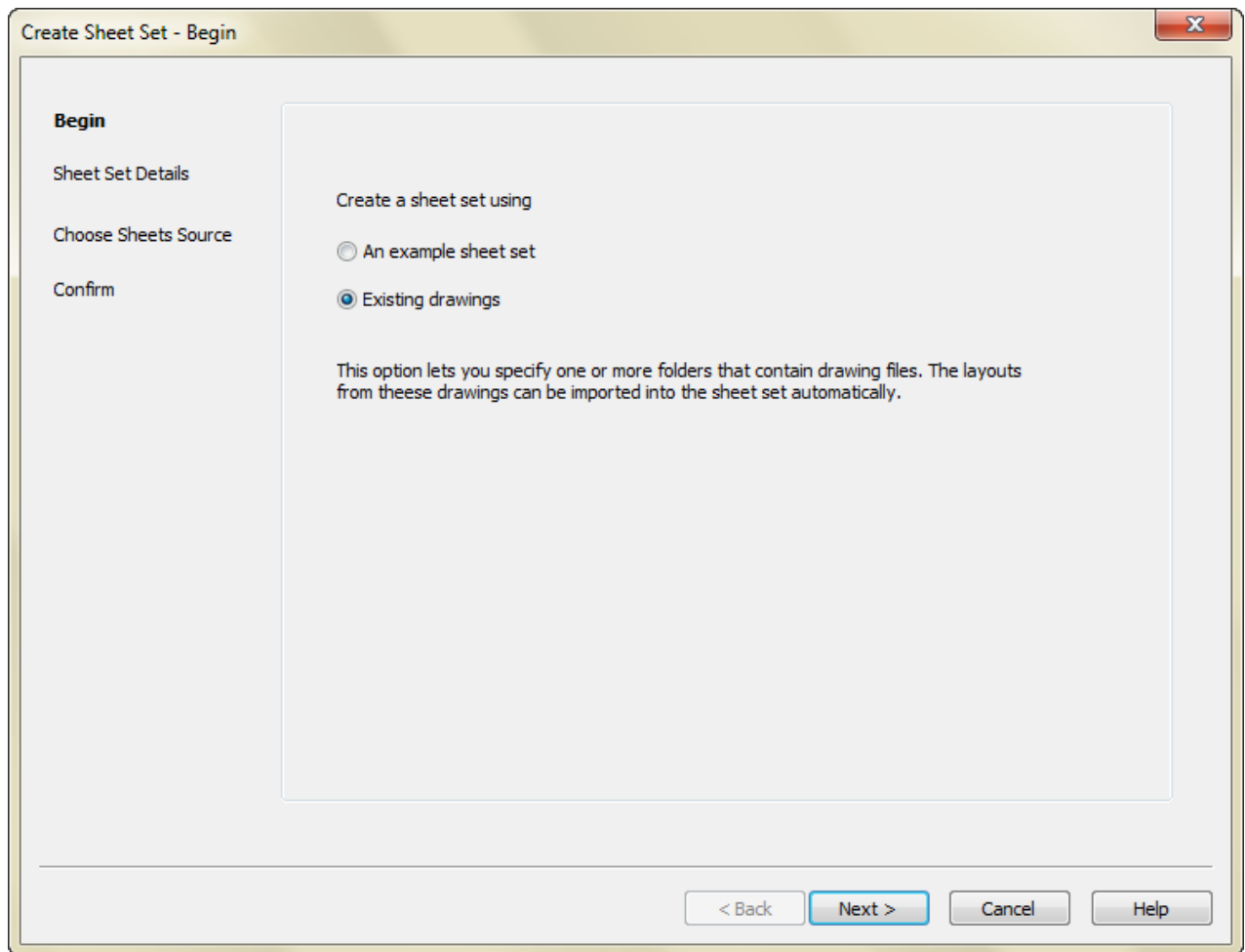

***To create a new sheet set using existing drawings:***

1. Choose **Existing drawings** from the **Create a sheet set using** options. Click the **Next >** button.
2. On the page **Sheet Set Details** put name of the new sheet set data file (.dst file).
3. On the same page click the **Sheet Set Properties** button and in the **Sheet Set Properties** window input necessary data for the sheet set (project number, project name etc.).

- Click **Next >** and go to the **Choose Layouts** page.

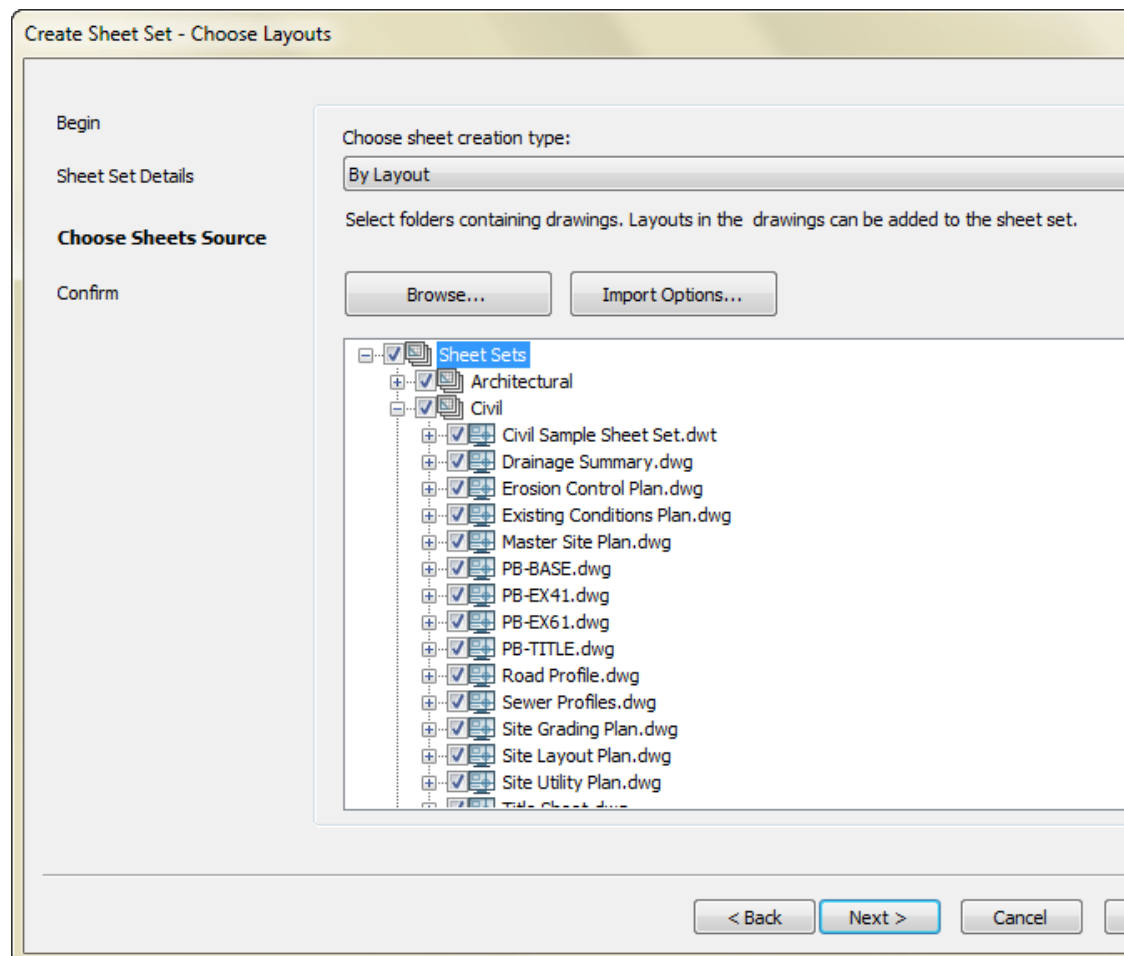

- In the **Choose sheet set type** drop-down list: take **By Layout** for the *set of layouts*, and take **By Named View** for the *set of views*.
- Using the **Import Options...** button arrange settings for creation of sheet subsets based on folder structure.

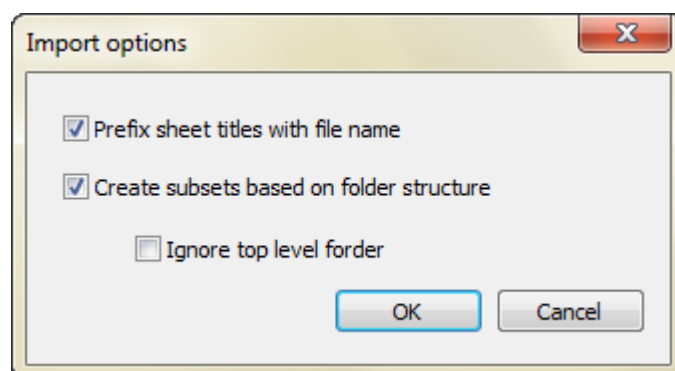

- On the **Choose Sheet Source** wizard's page click the **Browse...** button and select folder whose structure should be transferred as a tree to the central part of the **Choose Layouts** page. Repeat folder choosing if you want to add more layouts or views.
- In the tree check the layouts to be included into the set of layouts or the views to be included into the set of views.
- Using **Next >** go to wizard's **Finish** page.
- To complete sheet set creation click the **Finish** button.



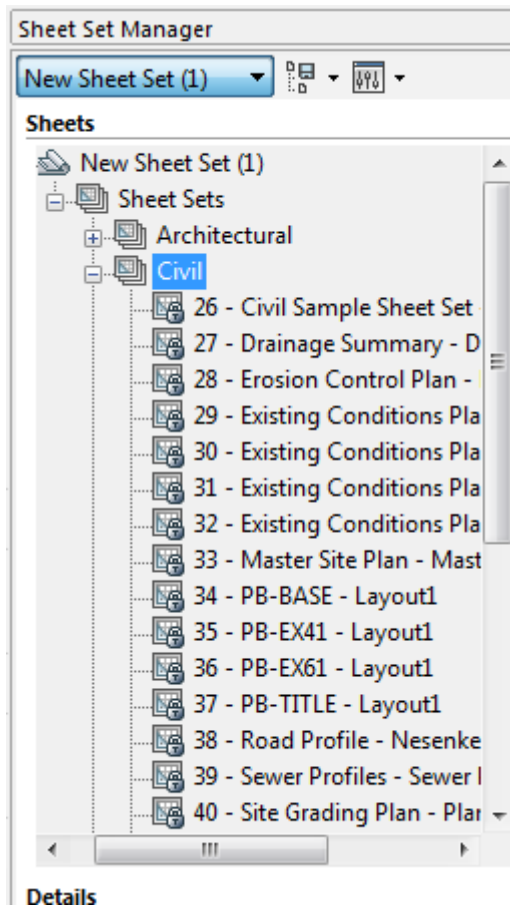

If the **Create subsets based on folder structure** checkbox was unset in the **Import Options...** dialog box then all the subfolders of the selected drawing files folder will be included into the sheet set as sheet subsets with the same names.

*To create a sheet set using an example sheet set:*

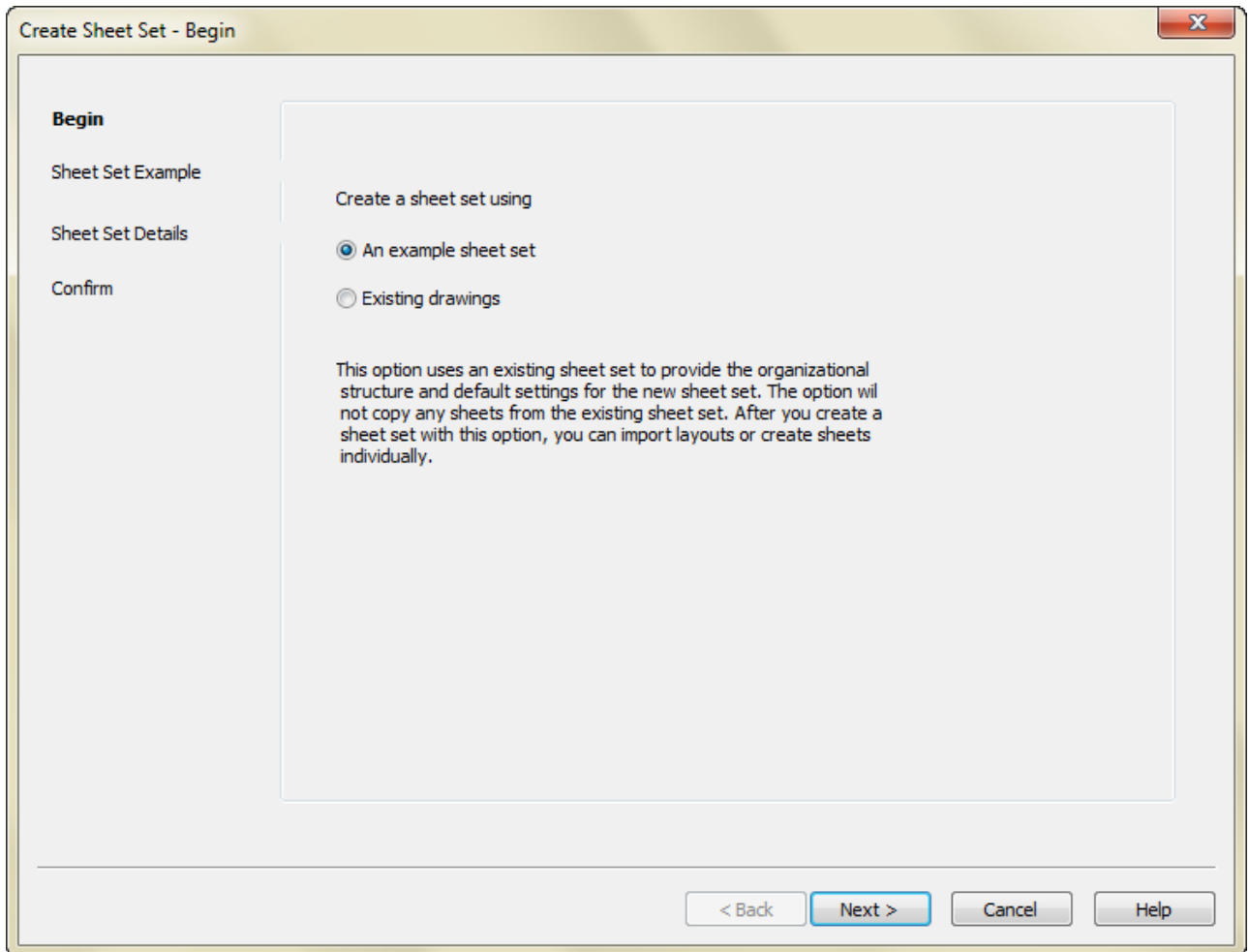

1. Select **An example sheet set** option in the **Create a sheet set using** radio buttons group. Click the **Next >** button.
2. Click **Select a sheet set to use as an example** or **Browse to another sheet set to use as an example** on the **Sheet Set Example** page. Press the **Next >** button.
3. On the **Sheet Set Details** page enter sheet set name, description and path to folder for placement. Fill in sheet set properties (use the **Sheet Set Properties** button).

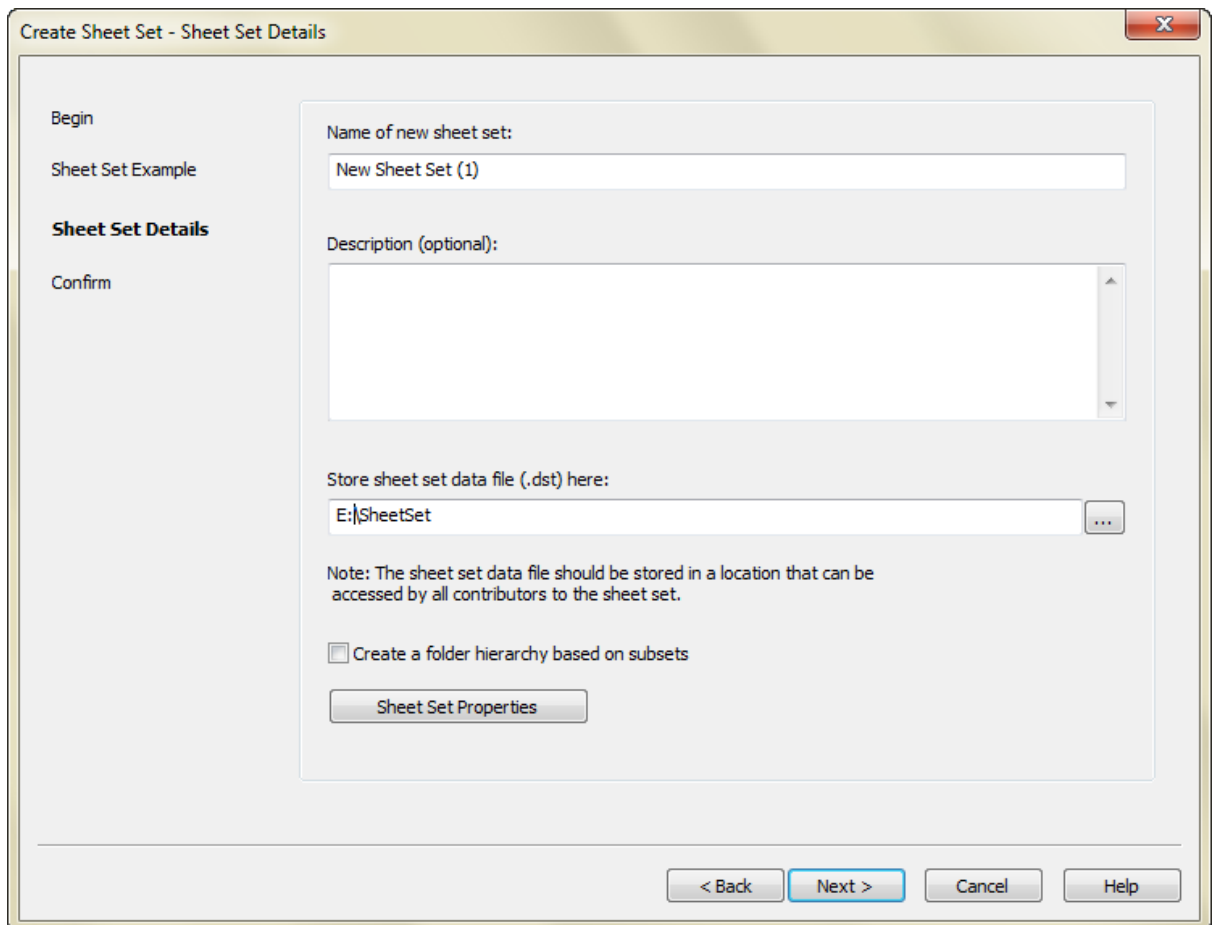

4. Examine thoroughly shown sheet set parameters on the **Finish** page.

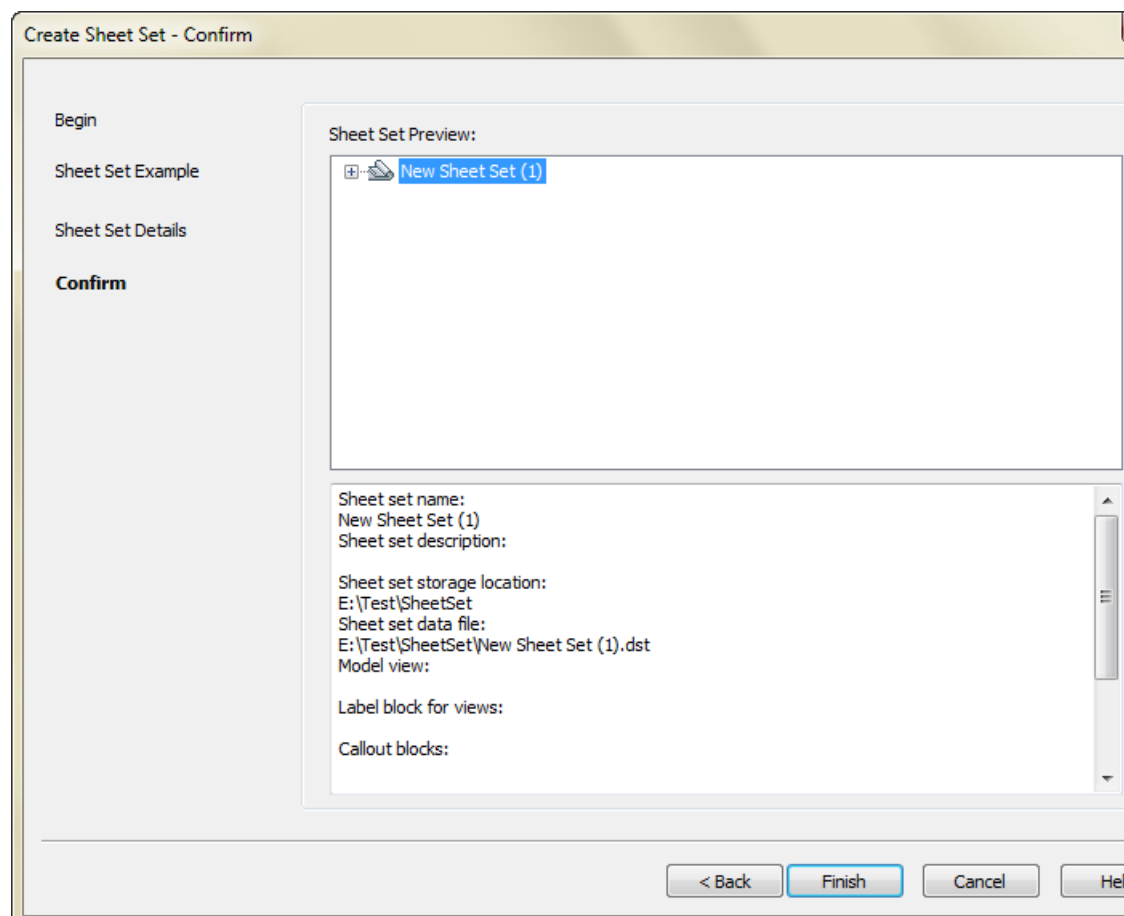

5. Click **Finish**.

As a result of this operation you get a sheet set tree in the center of the **Sheet Set Manager** functional bar. The tree based on the chosen example. The tree contains sheet subsets only and they are empty. You should add layouts and views later.

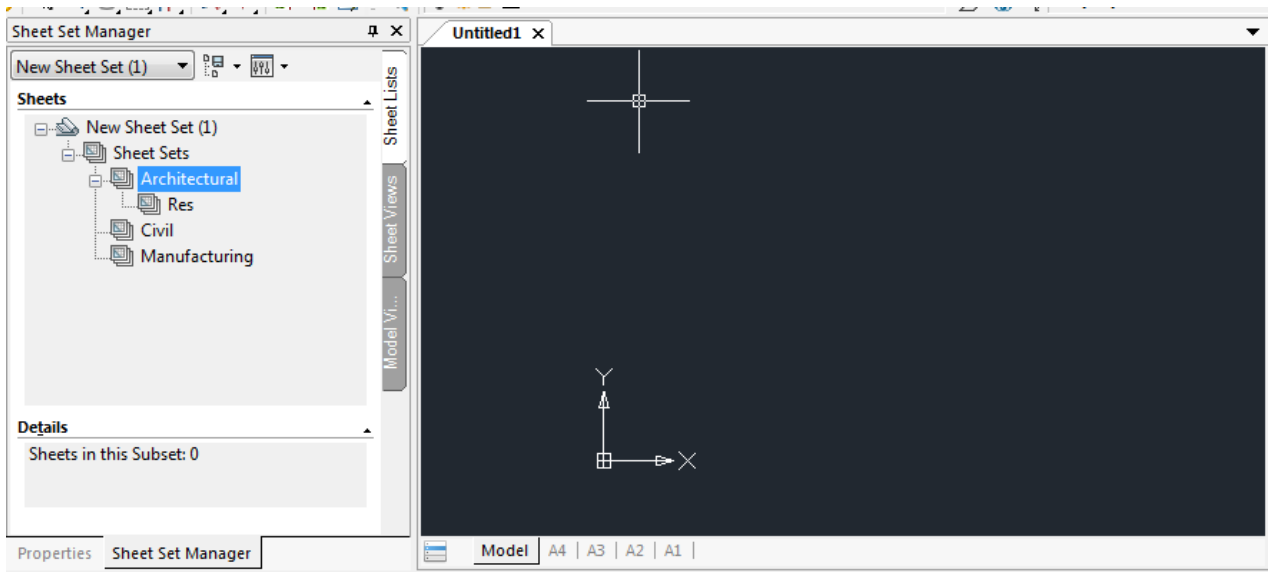

## Open Sheet Set



Menu: **File** –  **Open Sheet Set...**



Drop-down list of the **Sheet Set Manager** functional bar: **Open Sheet Set...**



Command line: **OPENSHEETSET**

The command opens a dialog box and you should select a sheet set data file (with .dst extension). Next in the central part of the **Sheet Set Manager** functional bar there will appear the sheet set's tree (and the sheet set will gain active status).

**NOTE:** If several sheet sets are open in the **Sheet Set Manager** functional bar then user can see the tree of the active sheet set only.

nanoCAD remembers names of the recently opened sheet sets and displays them in the drop-down list of the **Sheet Set Manager** functional bar. Click the name to open any of the recent sheet sets.

## Sheet Set Manager Functional Bar



Ribbon: **Manage – Palettes** >  **Sheet Set Manager**



Menu: **Tools** –  **Sheet Set Manager ...**



Menu: **View – Toolbars – Functional** –  **Sheet Set Manager...**



Toolbar: **Standard** – 



Command line: **SHEETSET**

The **Sheet Set Manager** bar has three tabs: **Sheet List**, **Sheet Views**, **Model Views**. They are filled by the active sheet set data depending on the set type (set of layouts or set of views).

It is possible to open one by one multiple sheet sets in the **Sheet Set Manager** functional bar. But at any moment only active sheet set is visible. Use drop-down list of the **Sheet Set Manager** to activate another opened sheet set..

## Set of Layouts

In the first tab of the **Sheet Set Manager** any *set of layouts* gets the tree and layouts distribution between the subsets.

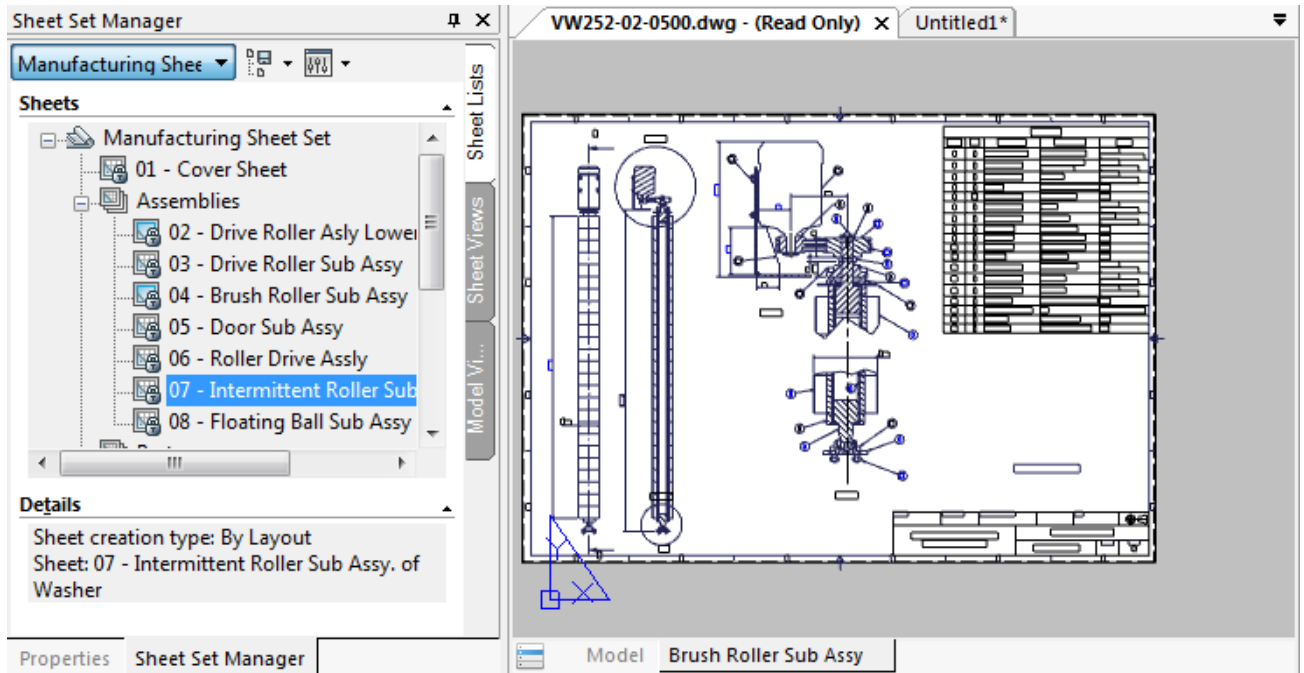

Double-click on a layout name to open this layout from the corresponding file.

The second tab (**Sheet Views**) displays layout subsets and layouts with the used named views.

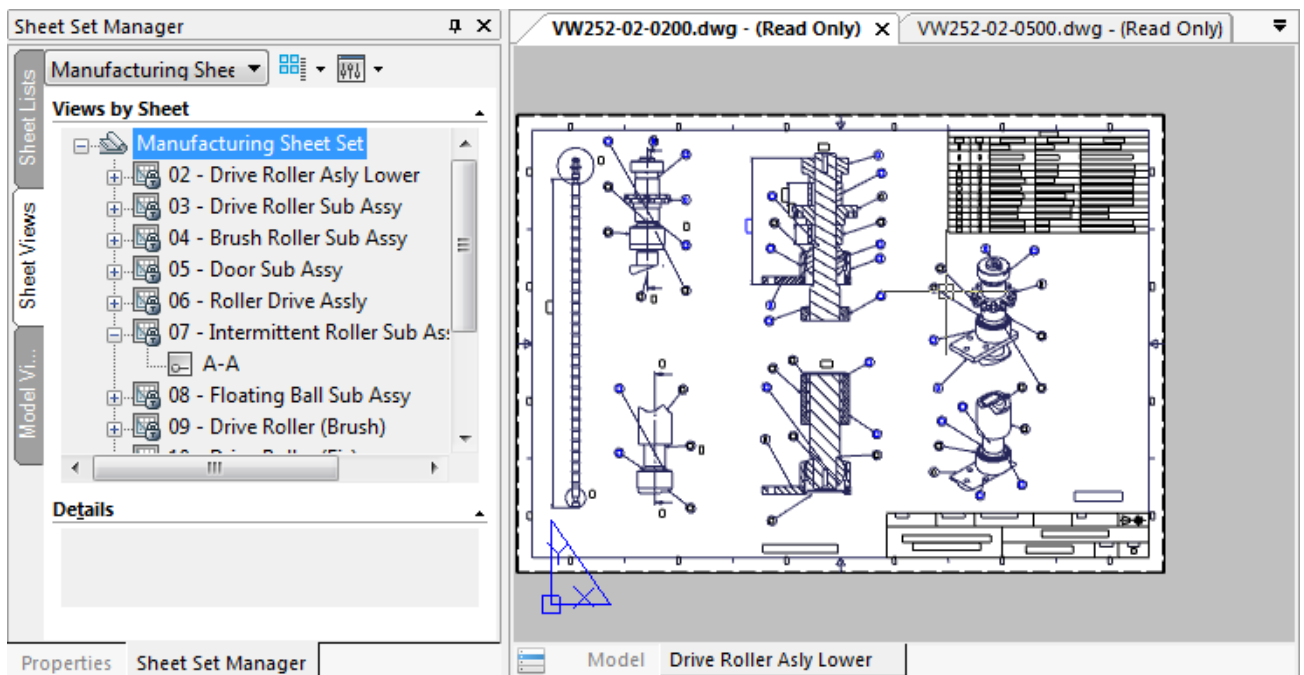

Click on a view name in the second tab to open this view from the corresponding file.

The third tab (**Model Views**) contains paths to the drawing folders and names of files with model views.

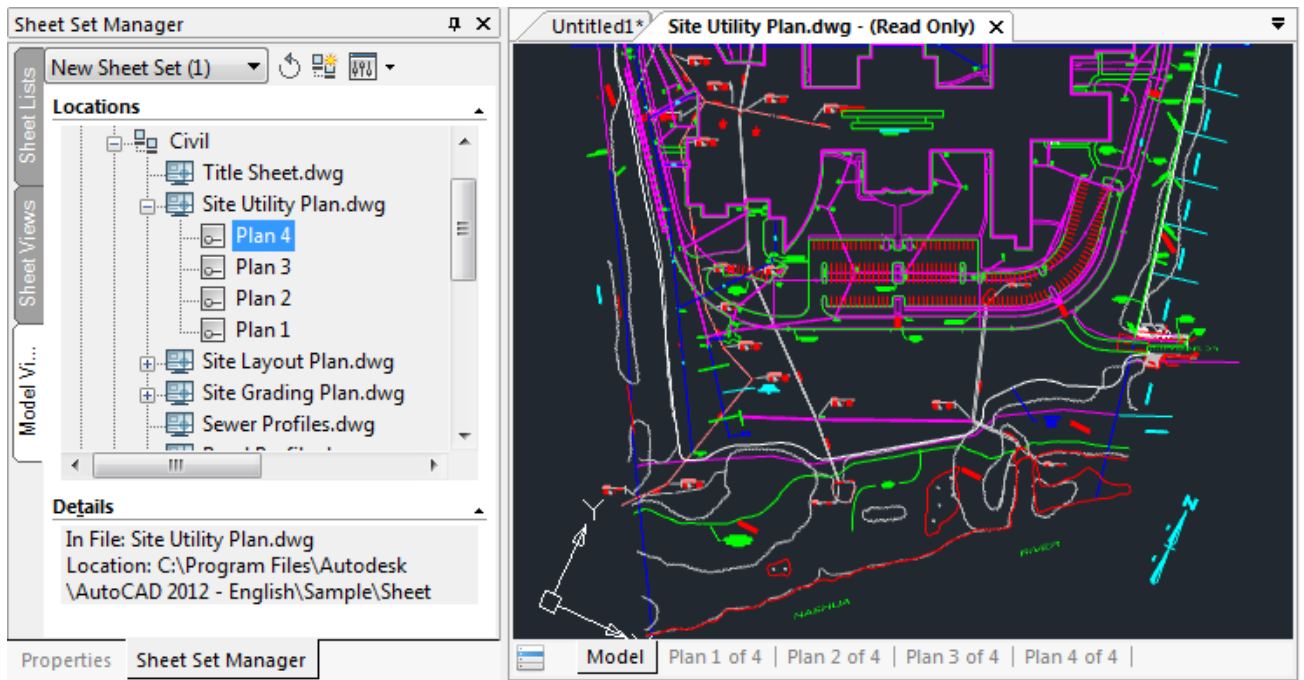

Double-click on a view name loads the corresponding file, switches to the **Model** tab and sets the selected view in it.

## Set of Views

The **Sheet Set Manager** functional bar contains views tree with their distribution between the groups is allocated.

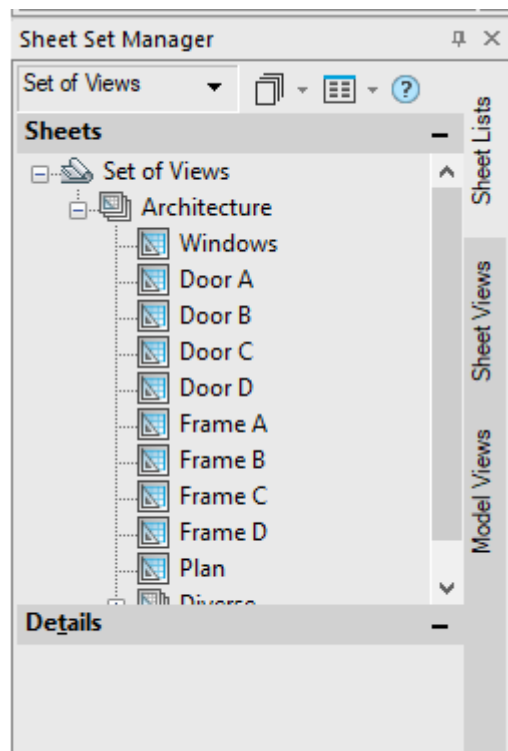

Double-click on a view name loads the corresponding file into the nanoCAD drawing area, switching to the **Model** tab and setting the necessary view in it.

The **Sheet Views** tab of the set of views is empty. The **Model Views** tab there can contain paths with model views allocated.

## Mixed Type Set

In the course of work it is possible to change the type of a sheet set. For example, on the **Sheet List** tab you can add a named view to the sheet set or add a layout in the sheet view. The result will be a *mixed type sheet set*, the elements of which are the model's layouts and named views on equal terms.

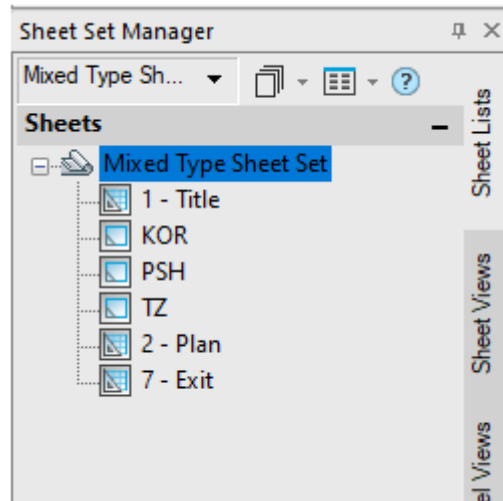

## Interface of the Sheet Set Manager

**Sheet Set Manager** functional bar interface includes also actions menu and buttons in the upper area. List of displayed buttons depends upon the tab that is opened.

### Sheet set actions menu



This menu has the following items:

- Names of opened sheet sets (to change active sheet set);
- **Recent** – list of recently opened sheet sets (for quick opening any one of them);
- **New Sheet Set...** – launches wizard for sheet set creation;
- **Open...** – opens an existing sheet set (and hides the previously opened sheet set in the functional bar);
- **Close Sheet Set** – closes the current sheet set and activates the previous one.

### Buttons of the Sheet List tab



Sheet actions menu:

- **Create...** – creates new sheet selection;
- **Manage** – opens the **Sheet Selections Manager** dialog (to create new selections and to edit existing selections structure).



Menu for altering window structure and tree display:

- **Collapse All** – collapses all the nodes lower than the first level;
- **Expand All** – expands all the tree nodes;
- **Details pane** – shows or hides the **Details** pane with the

selected tree item data;

- **Close** – closes the **Sheet Set Manager** functional bar.

### Buttons of the Sheet Views tab



Menu for setting display mode:

- **Views by Sheet** – displays by sheets;
- **Views by Category** – displays by view categories.



Menu for altering window structure and tree display:

- **Collapse All** – collapses all the nodes lower than the first level;
- **Expand All** – expands all the tree nodes;
- **Details Pane** – shows or hides the **Details** pane with the selected tree item data;
- **Close** – closes the **Sheet Set Manager** functional bar.

### Buttons of the Model Views tab



Tab refreshment button after editing.



Button to add new location folders for the files with model views.





Menu for changing window and tree display:

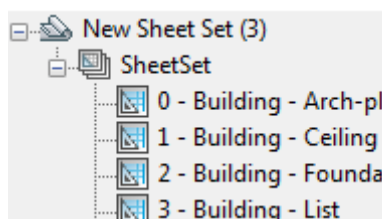

- **Details Pane** – shows or hides the **Details** pane with the selected tree item data;
- **Close** – closes the **Sheet Set Manager** functional bar.

## Sheet Set Tree Elements

The **Sheet Set Manager** deals with the following objects: sheet, subset, sheet selection, view, view category, callout block, view label block.





*Sheet set* always is the root node () in the tree.

Nodes in the tree can be generated by sheets () and by sheet subsets ()

*Sheet subset* is a named subset of sheets. Sheet subset has its own properties. Each sheet may belong only to a single subset or descend the root node.

*Sheet selection* is a named subset of sheets that is not displayed in the tree but can be used in some operations (plot etc.). Any sheet may be included into multiple sheet selections.

*Sheet* is layout or view that is included as a separate item into a sheet set.

*View* is a drawing named view that is located in a paper space viewport or in the model space. Layout views are located in the second tab of the **Sheet Set Manager** and are marked by the  icon. IModel views are located in the first tab of the **Sheet Set Manager** and are marked by the  icon.

Views are combined into named groups called *categories*.



All the sheet set tree elements have their own context menus where action commands are placed. Below there are context menus of a sheet set, a sheet subset, a sheet, a view files location, a source view file and a named view.

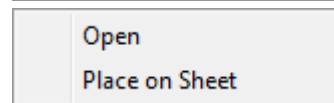
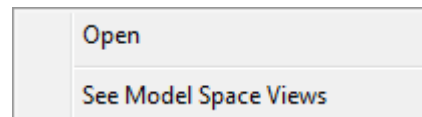
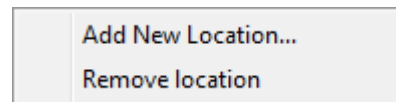
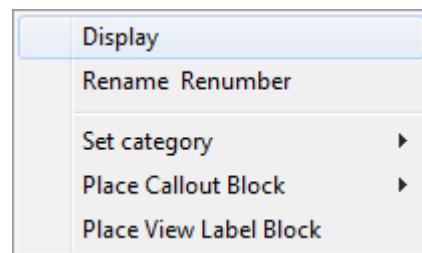
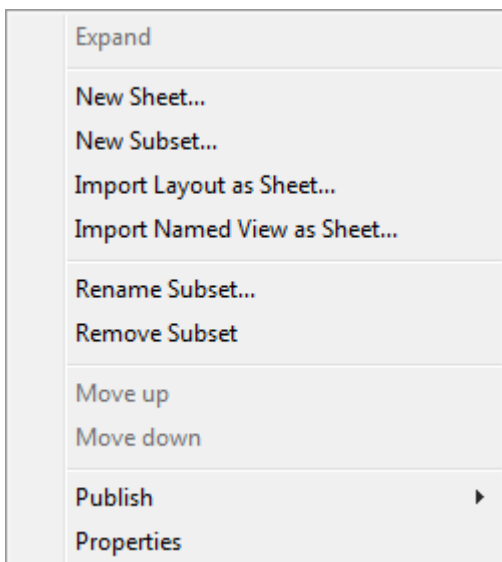
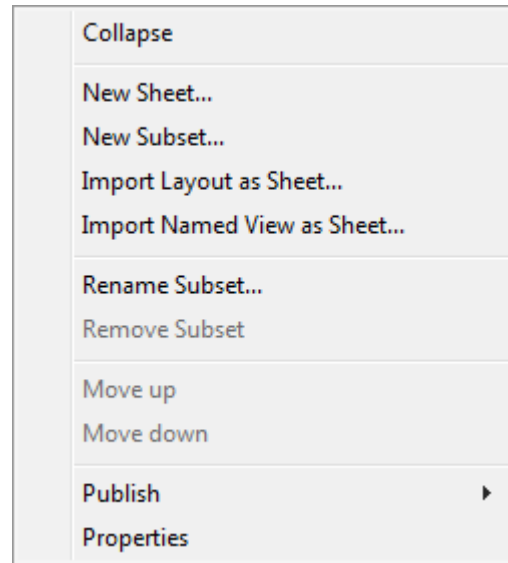
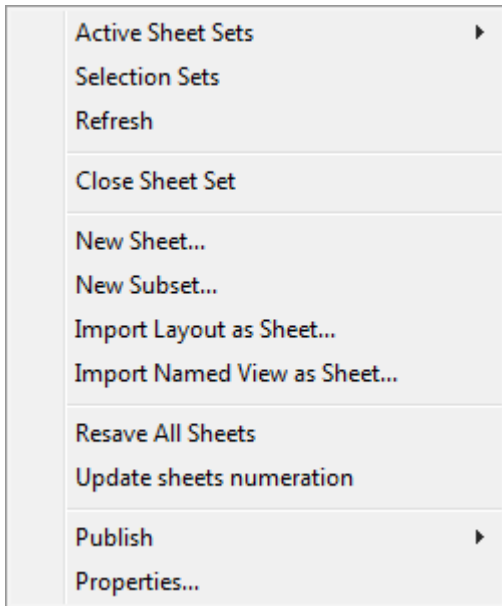

## Sheet Set Properties

Call the **Sheet Set Properties** dialog from context menu of sheet set.

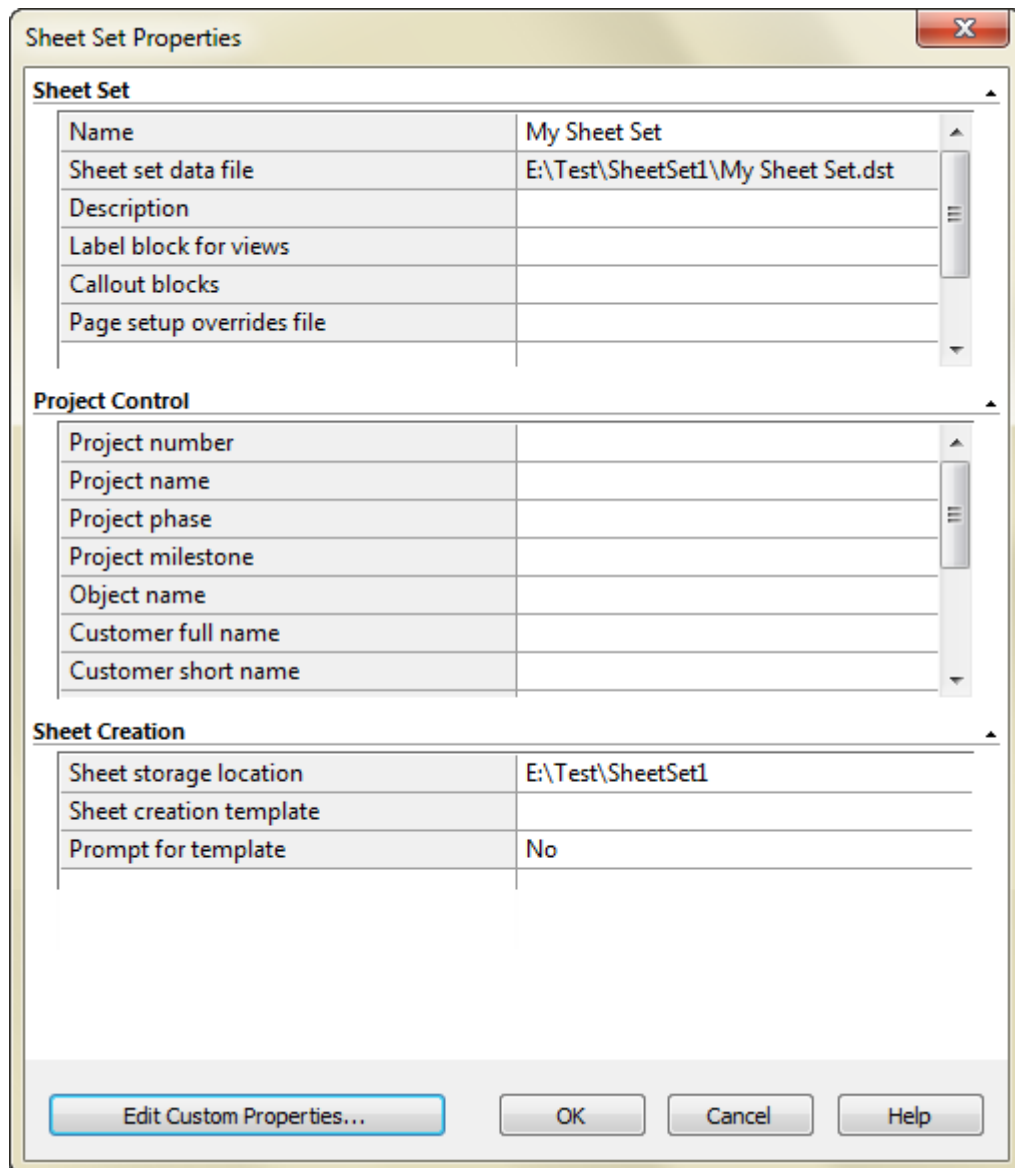

Sheet Set	
Name	My Sheet Set
Sheet set data file	E:\Test\SheetSet1\My Sheet Set.dst
Description	
Label block for views	
Callout blocks	
Page setup overrides file	

Project Control	
Project number	
Project name	
Project phase	
Project milestone	
Object name	
Customer full name	
Customer short name	

Sheet Creation	
Sheet storage location	E:\Test\SheetSet1
Sheet creation template	
Prompt for template	No

All the three parameters (properties) are distributed among three tabs: **Sheet Set**, **Project Control**, **Sheet Creation**.

**Sheet Set** tab involves the following general parameters:

- **Name** – sheet set name;
- **Sheet set data file** – .dst file name, with path;
- **Description** – annotation (description) saved with the sheet set;
- **Label block for views** – name and location of the block to be used as the view label block in the sheet set;
- **Callout blocks** – name and location of the block to be used as the callout block in the sheet set.

**Project Control** tab displays parameters associated with the project (number, name, phase, milestone, object, customer).

**Sheet Creation** tab displays the parameters concerned with the process of new sheets in the sheet set:

- **Sheet storage location** – folder for the new sheets to be created and added to the sheet set;
- **Sheet creation template** – name of the template to be applied to the new sheets;

- **Prompt for template** – indicates (yes or no) whether template name will be requested with every new sheet creation.

Values of the above mentioned properties can be used in the fields included into drawing text entities.

## Sheet Set Custom Properties

You can add custom properties for sheet set. Each custom property is associated with sheet, sheet subset or sheet set. Custom property values are displayed only with the owner sheet set and they can be used in the text fields.

Click the **Edit Custom Properties** button to add custom properties in the **Sheet Set Properties** window or in the **Sheet Subset Properties**. The **Custom Properties** dialog appears.

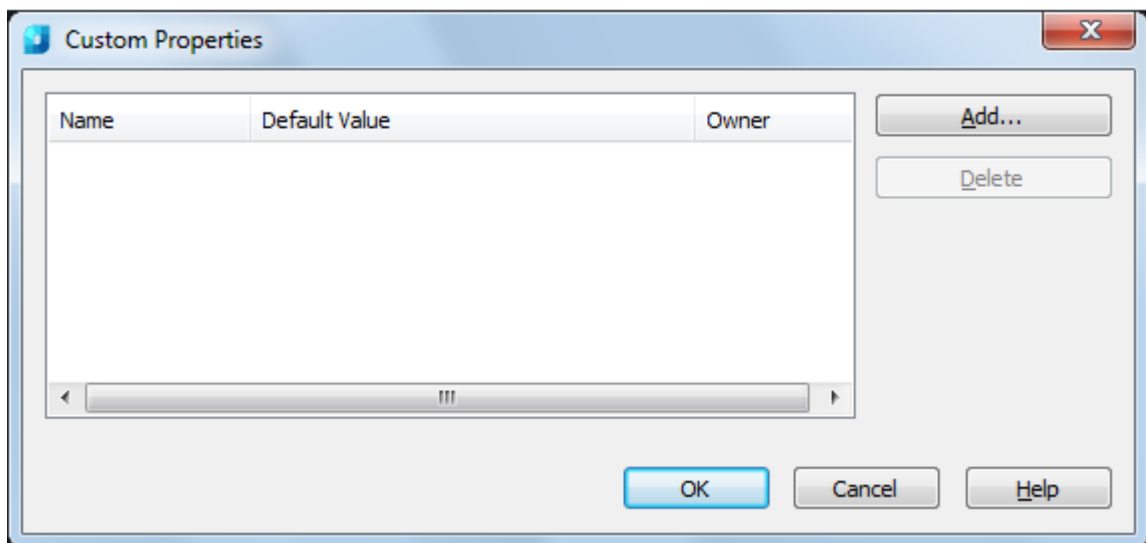

Add new custom properties (with **Add...**) or remove existing properties (with **Delete**).

Click the **Add...** button to open the **Add Custom Property** dialog. Enter new property name, default value (this value is added for the first time) and use radio buttons to choose the owner of the custom property: sheet set, sheet or sheet subset.

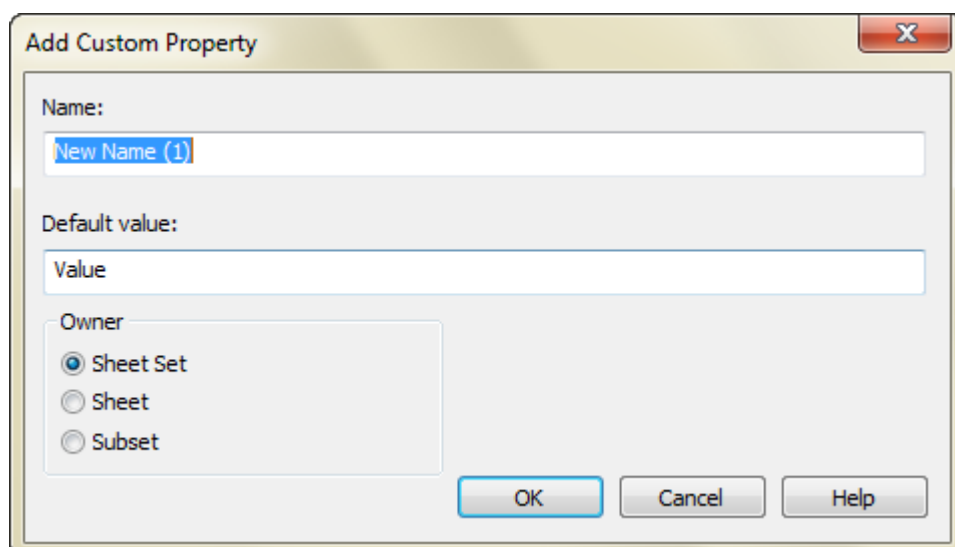

Additional property will be displayed in the **Custom Properties** dialog.

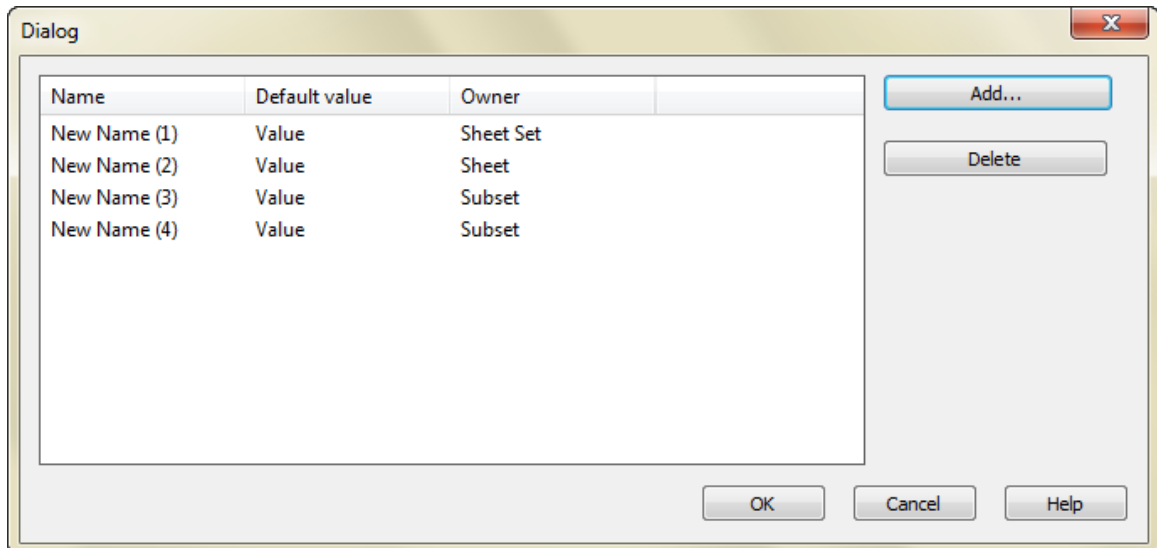

The **Sheet Set Properties** dialog shows custom properties in the special tabs depending upon the owner (sheet set, sheet subset or sheet).

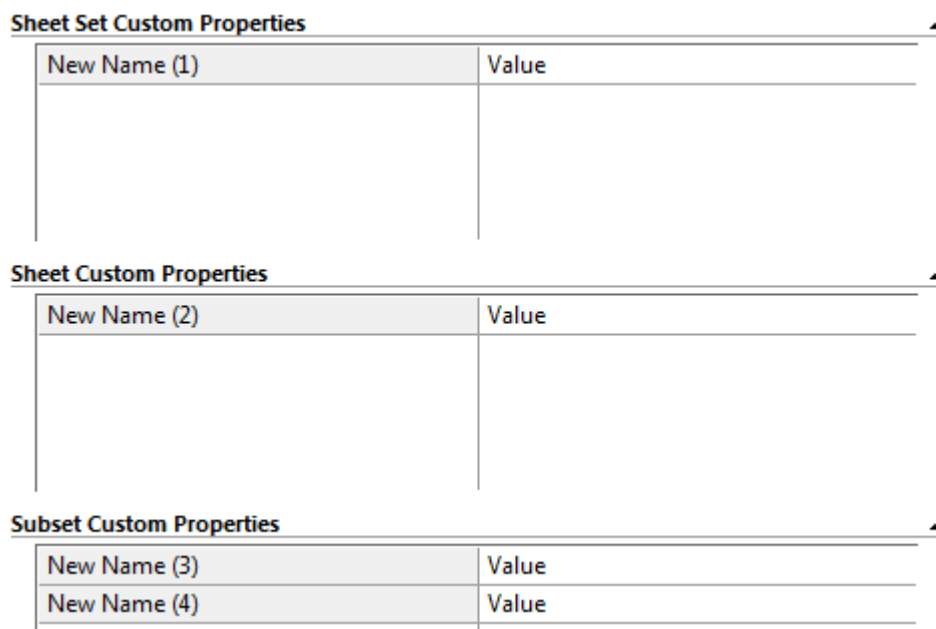

**Sheet Set Custom Properties, Sheet Custom Properties and Sheet Subset Custom Properties** contain the custom properties that are associated with the sheet set, sheet and subset.

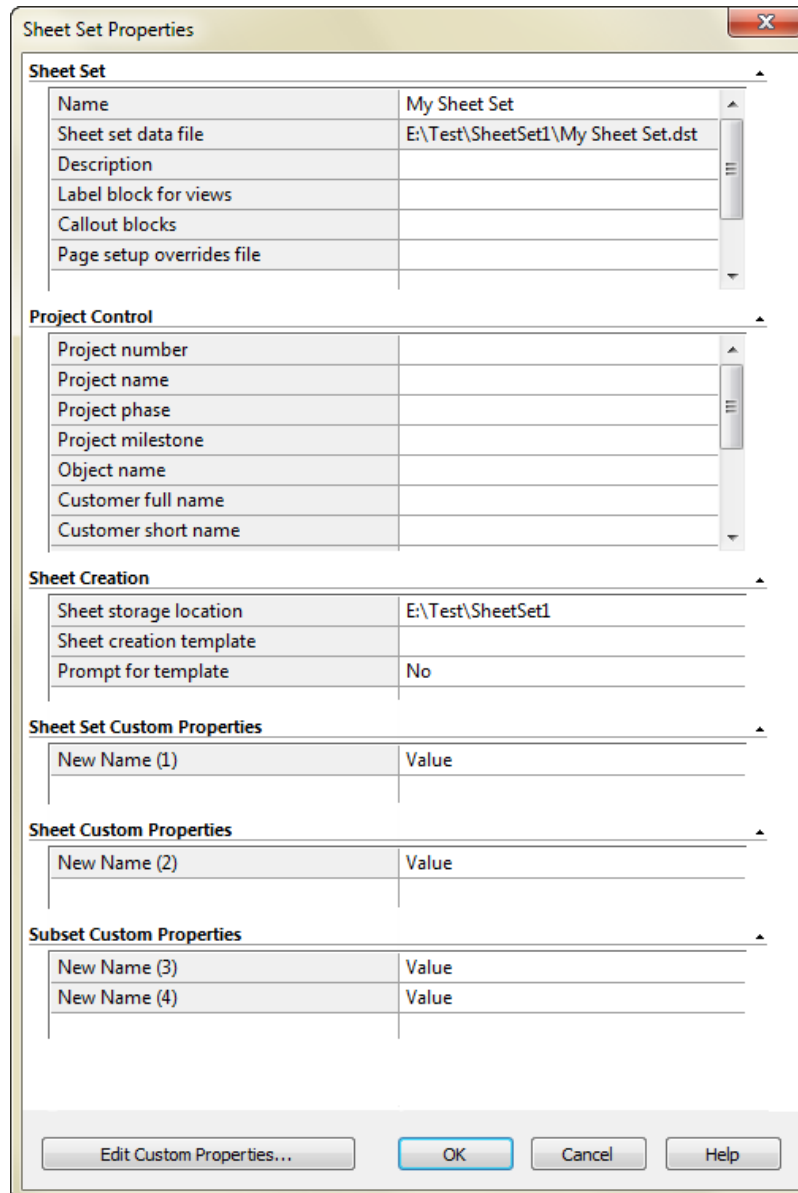

Sheet Set	
Name	My Sheet Set
Sheet set data file	E:\Test\SheetSet1\My Sheet Set.dst
Description	
Label block for views	
Callout blocks	
Page setup overrides file	

Project Control	
Project number	
Project name	
Project phase	
Project milestone	
Object name	
Customer full name	
Customer short name	

Sheet Creation	
Sheet storage location	E:\Test\SheetSet1
Sheet creation template	
Prompt for template	No

Sheet Set Custom Properties	
New Name (1)	Value

Sheet Custom Properties	
New Name (2)	Value

Subset Custom Properties	
New Name (3)	Value
New Name (4)	Value

It is possible to edit values of properties in the **Sheet Set Properties** dialog.

Edit main and custom properties of sheet and subset in the **Sheet Properties and Subset Properties** dialogs opened with the **Properties** context menu. Similar properties of a specific sheet can be changed in the **Sheet Properties** dialog from the context menu **Properties**.

## Blocks in the Sheet Sets

Connect sheets of sheet set via callout blocks and view label blocks in the drawings. Names of blocks and files with definitions can be input in the **Sheet Set** tab of the sheet set properties dialog.

### Label Block for Views

Label block is used as a label of view, label contains context-dependent fields with view parameters, e.g. view number, view name in the sheet set and viewport scale.



# SECOND FLOOR

Scale: 1:100

## Callout Blocks

Callout blocks are used to generate drawing links to other views and layouts. Here is a sample of callout block:

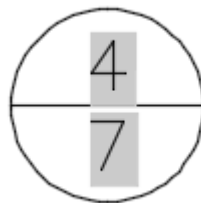

The block has two attributes with values based on fields. The upper attribute displays view number and the bottom one shows sheet number in the sheet set. Attributes can have hyperlinks for fast transit to the view or to the layout.

## Actions on Sheet Set And Its Elements

This topic deals with the actions committed in the **Sheet Set Manager** over sheet sets, sheets, sheet sunsets, sheet selections, views, view categories and invoked from the context menus or from the supplementary dialogs.

### Activate opened sheet set



The **Sheet List** tab, root node context menu: **Active Sheet Set** – click on sheet set name

### Close active sheet set



The **Sheet List** tab, root node context menu: **Close Sheet Set**

### Refresh active sheet set



The **Sheet List** tab, root node context menu: **Refresh**

### Resave all sheets of active sheet set



The **Sheet List** tab, root node context menu: **Resave All Sheets**



The resave operation is necessary to update all links between sheets and DST file with the sheet set data. Properties of elements are updated in accordance with the current state. At the same time, the fields referring to the set and its elements are updated in the current drawing. Required after importing sheets.

### Batch plot active sheet set





The **Sheet List** tab, root node context menu: **Publish**

### *Create new sheet in the sheet set*

-  The **Sheet List** tab, root (subset, sheet) node context menu: **New Sheet...**
-  Context menu of the sheet set node on the **Sheet list: New sheet...** tab
-  Context menu of the sheet node on the **Sheet list: New sheet...** tab



### *Import layout as a sheet*

-  The **Sheet List** tab, root (subset, sheet) node context menu: **Import Layout as Sheet...**
-  Context menu of the sheet set node on the **Sheet list: Import Layout as Sheet...** tab
-  Context menu of the sheet node on the **Sheet list: Import Layout as Sheet ...** tab

### *Remove sheet from the sheet set*

-  The **Sheet List** tab, sheet node context menu: **Remove sheet**



### *Move sheet in the sheet set tree*

-  Context menu of the sheet node on the **Sheet list: Move Up** tab
-  Context menu of the sheet node on the **Sheet list: Move Down** tab

### *Change sheet name and number*

-  The **Sheet List** tab, sheet node context menu: **Rename Renumber...**

### *Create new sheet subset*

-  The **Sheet List** tab, root (subset) node context menu: **New Subset...**
-  Context menu of the sheet set node on the **Sheet list: New Subset...** tab





### *Rename selected subset*

-  The **Sheet List** tab, subset node context menu: **Rename Subset**

### *Remove selected subset*

-  The **Sheet List** tab, subset node context menu: **Remove Subset**

### *Create a sheet list for a sheet set*

-  Context menu of the root node on the **Sheet list: Insert Sheet List Table** tab
-  Context menu of the sheet set node on the **Sheet list: Insert Sheet List Table** tab
-  Context menu of the sheet node on the **Sheet list: Insert Sheet List Table** tab
-  Context menu of the sheet selection on the **Sheet list: Insert Sheet List Table** tab

The **Insert Sheet List Table** command inserts a table according to the standard dimension requirement of GOST R 21.1101-2013.

Requests for the table insertion point. It can be called from the context menu of an individual sheet, a sheet selection, a subset, root node. The command is available if a sheet from the set is opened and is active.

The provided sheet set templates DefaultSheetSetTemplateGOST.dwt and DefaultSheetSetTemplateSPDS.dwt contain already all necessary settings.

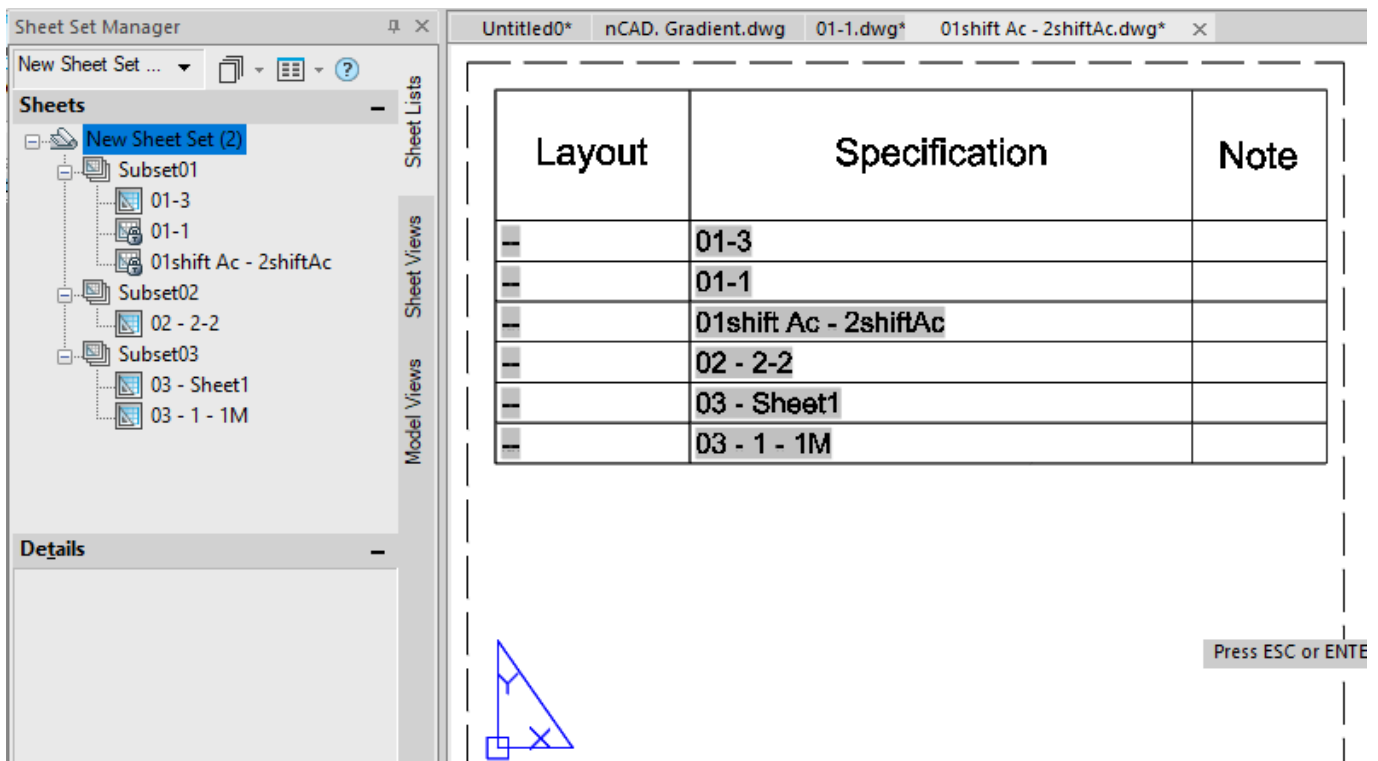

If you need to use other style for a sheet set, it is necessary to preliminary specify the desired table style in the table style dialog box or using the CTABLESTYLE variable.

### Create new sheet selection (option 1)

Select sheets and subsets in the sheet set tree.



The **Sheet List** tab:  - **Create...**

### Create new sheet selection (option 2)



The **Sheet Selection Set Manager** dialog: **New**



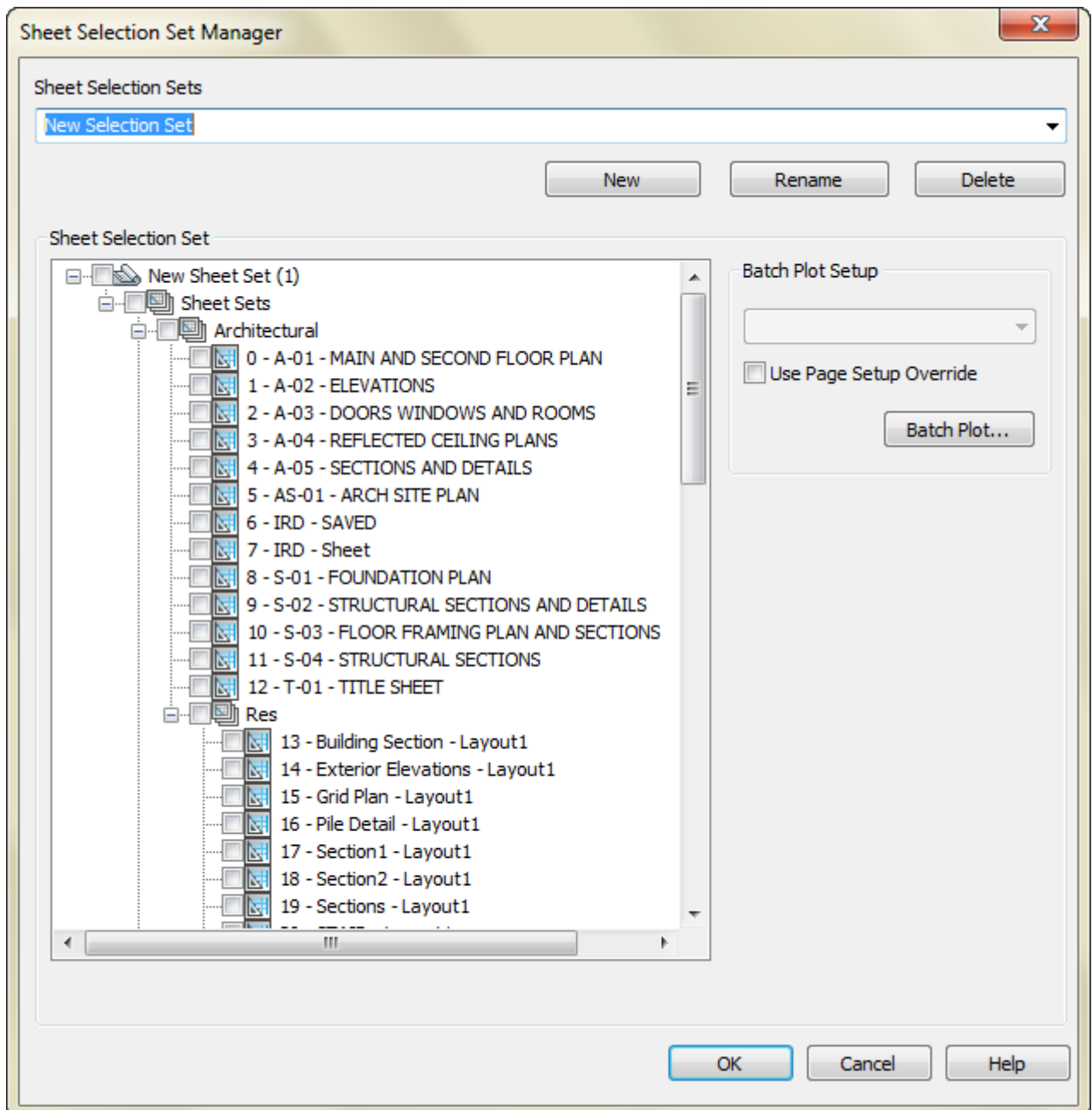

Check sheets to be included into selection.

### *Rename sheet selection*



The **Sheet Selections Manager** dialog: **Rename**

### *Delete sheet selection*



The **Sheet Selections Manager** dialog: **Delete**

### *Set View by categories mode*



The **Sheet Views** tab:  – **View by Category**

### *Set View by sheets mode*



The **Sheet Views** tab:  – **View by Sheet**

### *Create new view category*



The **Sheet Views** tab: the **View by Category** mode – root node context menu – **New View Category...**

### *Rename view category*



The **Sheet Views** tab: the **View by Category** mode – view category node context menu – **Rename...**

### *Delete view category*



The **Sheet Views** tab: the **View by Category** mode – view category node context menu – **Remove**

### *Edit view category properties*



The **Sheet Views** tab: the **View by Category** mode – view category node context menu – **Properties**

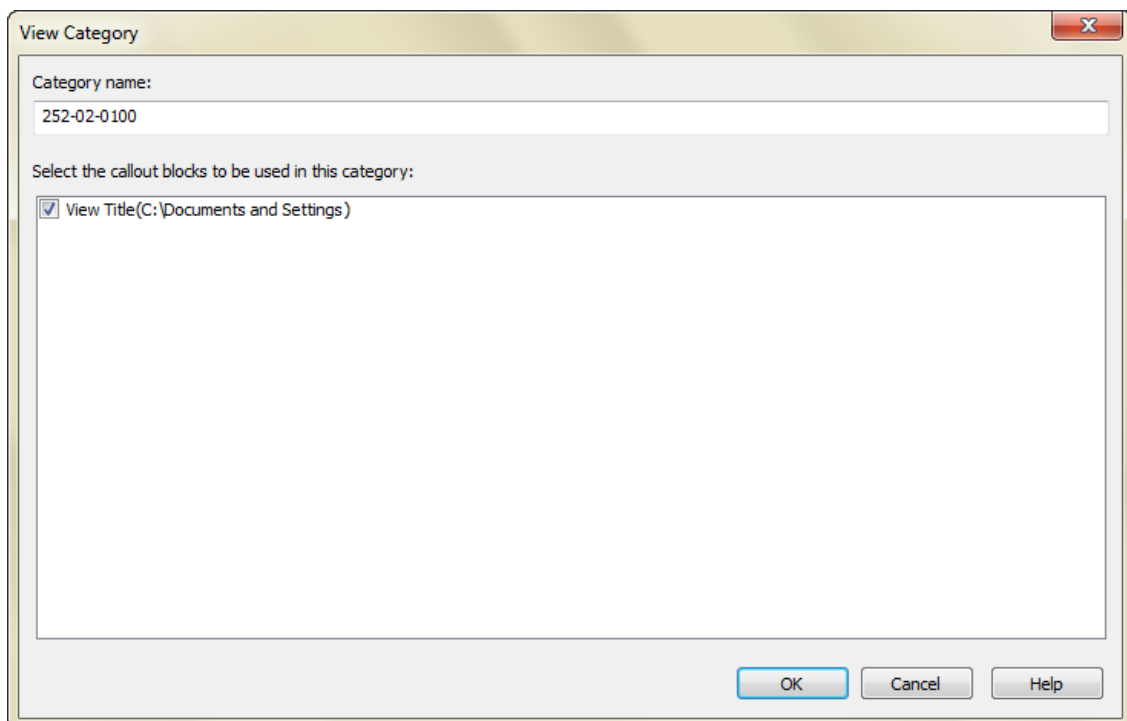

### *Set existing category to a view*



The **Sheet Views** tab: the **View by Sheet** mode – view node context menu – **Set category**

### *Insert view to sheet*



The **Model Views** tab: view node context menu – **Place on Sheet**

### *Change view name and number*



The **Sheet Views** tab: view node context menu – **Rename Renumber**

### *Import named views*



The **Sheet List** tab, root node context menu: **Import Named View as Sheet...**



The **Sheet List** tab, subset node context menu: **Import Named View as Sheet ...**

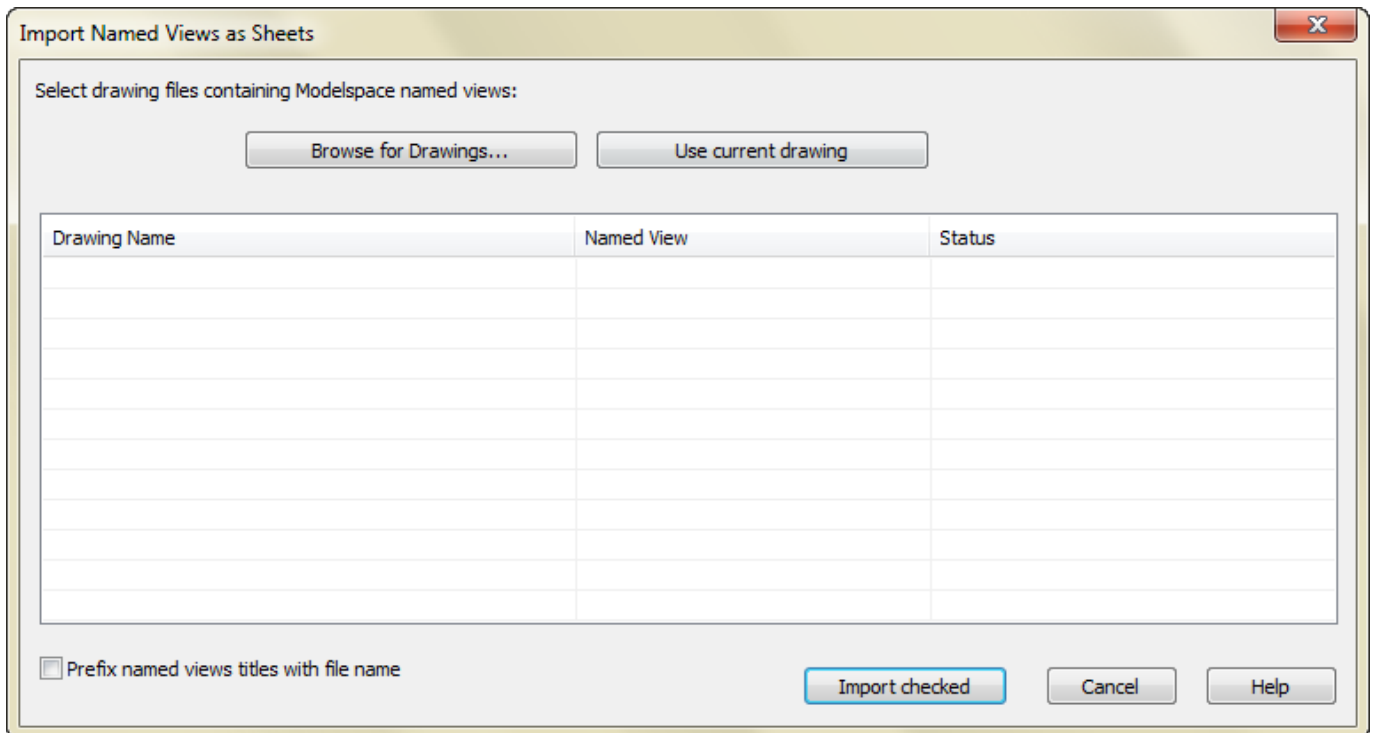

Use **Browse for Drawings...** and **Use current drawing** buttons to select files for import named views to the active sheet.

***Insert view callout block***



The **Sheet Views** tab: view node context menu – **Place Callout Block**

***Insert view label block***



The **Sheet Views** tab: view node context menu – **Place ViewLabel block**

***Add new model views location***



The **Model Views** tab: root node context menu – **Add New Location...**

# COMMAND SCRIPTS AND EXTENSIONS

---

## Command Scripts (SCR)

Command scripts are convenient for often performance of certain sequence of actions. Command script is a text file with .scr extension, which contains a set of instructions intended to be executed in nanoCAD command line. Each line of the file contains a command or reference to another script.

There are following commands to work with scripts:

-  **SCRIPT** – loads the script file and consistently performs instructions described in this file. If any script is active at the moment the SCRIPT command is invoked, the script is stopped;

**SCRIPTCALL** – similar to SCRIPT command that additionally admits nested scripts;

- **RESUME** – continues an interrupted script;
- **RSCRIPT** – repeats the last script.

Script files can be created outside the program with help of any text editor. The launched command is written with a new line of the file with parameters values requested by it, positioned through space. Each space in a script is significant, it is similar to pressing ENTER or SPACE.

In case it is necessary to work with command which, when being performed, displays dialog box, use its version without dialog with a hyphen before the command name. For example, you can use -DIMSTYLE instead of DIMSTYLE command.

Scripts can contain comments. Any line that begins with a semicolon (;) is considered a comment, it is ignored while the script is being processed.

The last line of the script must be blank.

Names of files and named objects (layers, styles) that contain spaces must be enclosed in double quotes.

You can run a script at [nanoCAD](#) startup from the operating system's command line using **-s** switch.

## Software Extensions

nanoCAD allows you to use different software to extend its functionality: add new commands, entities, tools for editing and document management, database.

nanoCAD supports the following programming interfaces:

- *NrxGate* - C++ API, is designed to create and transfer applications on C++, allowing you to create new entities;
- *.NET API* - is designed to create .NET applications;
- *MultCAD API* - C++ API, is designed to write cross-platform CAD applications, allowing you to create new entities;
- *MultCAD .NET API* - .NET API, designed for developing cross-platform CAD-applications, creating new primitives

- *COM API* - is designed to write automation scripts and create commands in JScript, VBScript, manage external nanoCAD applications via ActiveX®;
- *LISP API* - is the dialect of LISP, designed to automate work in nanoCAD.

The documentation of nanoCAD's API, examples of applications and scripts are available for members of [nanoCAD Developers' Club](#).

## NRX and LISP File Loading



Ribbon: **Manage – Applications - Applications >**  **Load Application**



Menu: **Tools – Application >**  **Load application...**



Command line: **APPLOAD**

The command allows you to load NSF, MultiCAD API, LISP, .NET and NRX-applications to nanoCAD.

After starting the command the **Load/Upload Applications** dialog box appears:

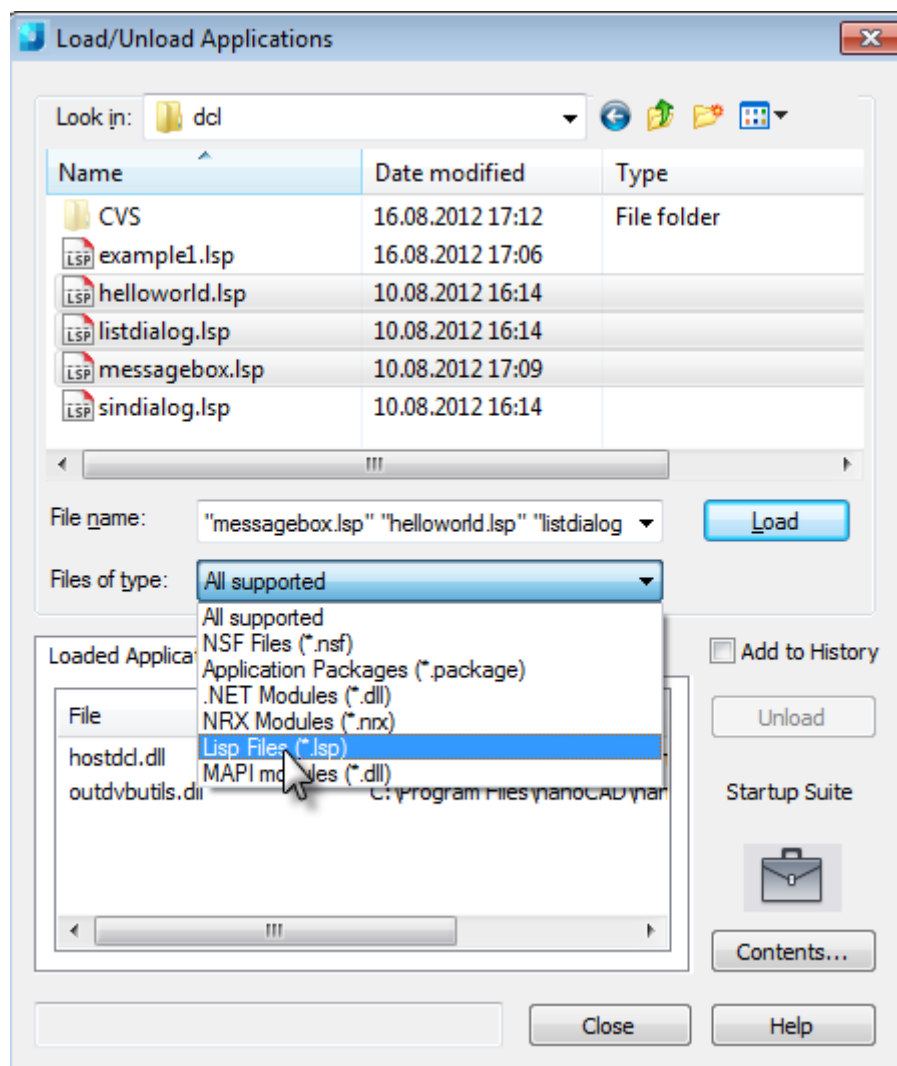

To load a file, select it in the top of the dialog box and click the **Load** button. All files loaded in this nanoCAD session display in the list of the **Loaded applications** tab.

To record the history of the loading, select the **Add to history** checkbox. The list of previously loaded files can be viewed on the **History list** tab.

It is possible to automatically load the applications when you start nanoCAD. To do this, click the **Contents** button in the opened dialog box and add the files that should be automatically loaded for each new nanoCAD session.

After loading of the NSF, NRX, MultiCAD, .NET or LISP application, its commands, that can be started from the nanoCAD's command line, are available.

**NOTE:** Unlike AutoCAD, where a LISP-application is loaded only into the current document, the commands of LISP-applications loaded in nanoCAD are available during whole working session from any documents.

## *.NET Application Loading*

 Ribbon: **Manage – Applications - Applications >**  **Load .NET application**

 Menu: **Tools – Application >**  **Load .NET application**

 Command line: **NETLOAD**

To load a NET-application, start the command and in the opened dialog box select the necessary dll-file.

The command of loaded NET-application are available from the any documents during whole nanoCAD working session.

## *JScript Loading*

 Ribbon: **Manage – Applications - Scripts >**  **JScript**

 Menu: **Tools – Scripts >**  **JScript...**

 Command line: **JS**

After starting the command, select the necessary file with js extension in the opened dialog window. Script execution begins immediately after loading.

## *VBScript Loading*

 Ribbon: **Manage – Applications - Scripts >**  **VBScript**

 Menu: **Tools – Scripts >**  **VBScript...**

 Command line: **VBS**

After starting the command, select the necessary file with vbs-extension in the opened dialog window. Script execution begins immediately after loading.

## *NSF Files Loading*

 Command line: **NSF**

It is possible to register the scripts as nanoCAD commands. To register js or vbs-scripts (both one and whole packet), a programmer create NSF-file (the defined structure XML-file), which subsequently is loaded to nanoCAD with **NSF** command by user.

When the NSF-file is loaded, its command makes available.

## Work with LISP-Applications

 Ribbon: **Manage – Applications - Scripts** >  **Lisp**

 Menu: **Tools – Scripts** >  **Lisp**

 Command line: **LSP**

After starting the command, select the necessary option in the command line.

### Options:

COmmands  
Function  
S  
Variable  
S  
Load

Outputs the commands, LISP variables and loaded LISP-applications to the command line.

Execute

Allows to load LISP-file with **lsp** or **mnl** extension by entering whole path of the file and its extension.

Console

Allows to execute one of the functions **lsp** or **mnl** file, that was loaded by using the Load option.

Converts nanoCAD command line to the LISP console mode. In this case, the command prompt changes to `_>`:

```

Command Line
x Command: LSP
lsp - lsp
Enter an option or [cOmmands/Functions/Variables/Load/Execute/Console/]: Console
_>: (setq a 5)
5
_>: (+ a 3)
8
_>:

```

In the nanoCAD, entered function can be performed in the Console mode. To exit the LISP-console mode, enter `(quit)` or `(exit)`.

## The ncad.lsp file

The root nanoCAD folder contains important `ncad.lsp` file that is being automatically loaded on nanoCAD session start. The `ncad.lsp` is a text file that should have a correct LISP application structure. It can include function definitions, command definitions (they are to be created as functions with the C: prefix) as well as executable LISP expressions and comments.

After loading `ncad.lsp` a message in command line is generated. It displays names of the commands defined inside the file, e.g.:

```
nCad.lsp loaded. Commands: RESETVAR, DWGCLEAR
```

It is possible to include executable expressions in `ncad.lsp` file to load additional applications, set values for LISP variables and etc.:

```
(setq @@PATH "D:\\MyPlugins\\")
;Loading applications
(load (strcat @@PATH "lspplugin.lsp"))
(arxload (strcat @@PATH "nrxplugin.nrx"))
(apload (strcat @@PATH "nsfplugin.nsf"))
```

## Script Editor (JS, VBS, LSP, DCL, SCR)

 Ribbon: **Manage – Applications** >  **Script Editor**

 Menu: **Tools – Scripts** >  **Script Editor...**

 Command line: **SCRIPTED**

The built-in script editor allows you to create, edit and run batch files of various formats: ActiveX (.JS, .VBS), LISP (.LSP), DCL, SCR.

The script editor window is a functional bar, the title of which contains the name of the file being edited.

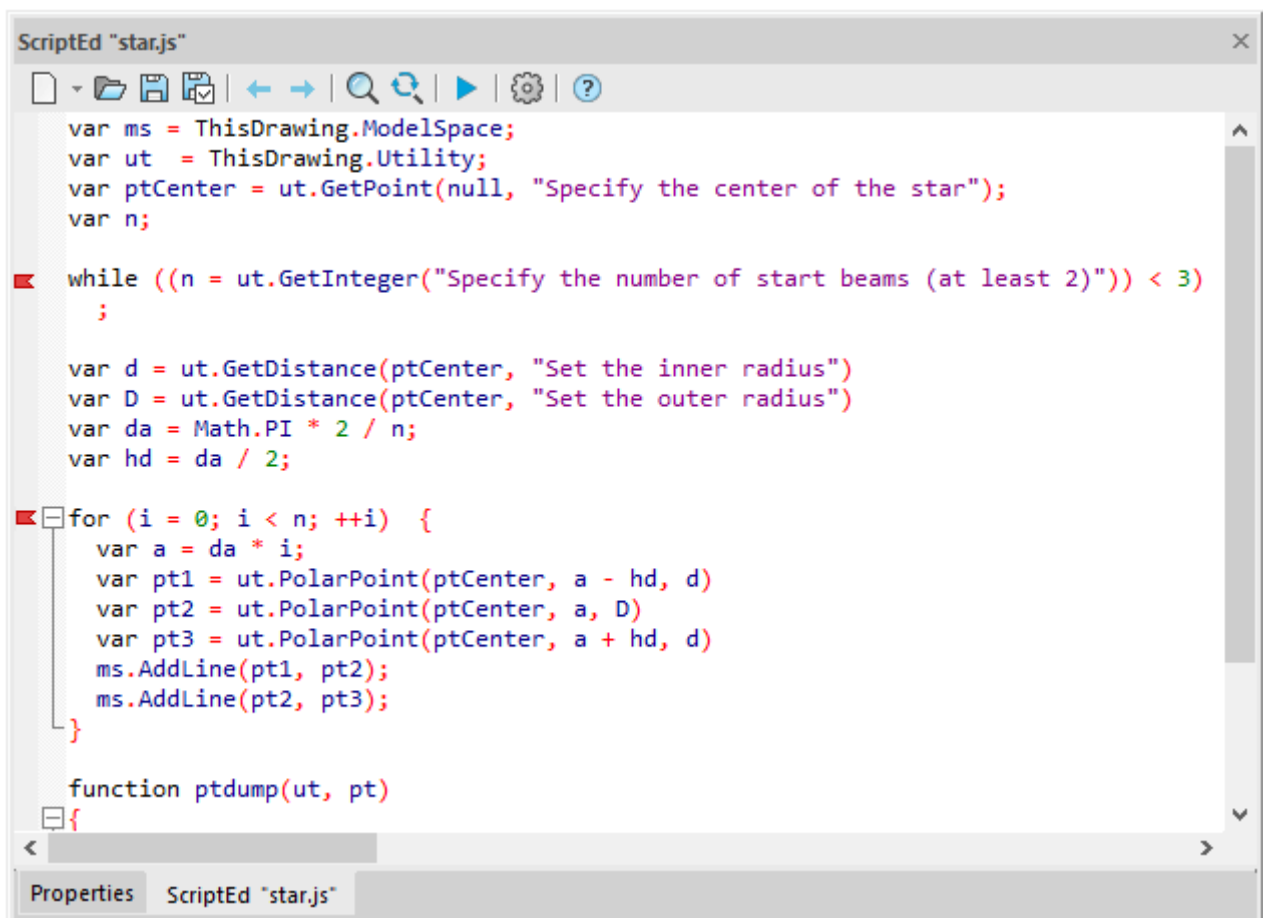

```

ScriptEd "star.js"
var ms = ThisDrawing.ModelSpace;
var ut = ThisDrawing.Utility;
var ptCenter = ut.GetPoint(null, "Specify the center of the star");
var n;

while ((n = ut.GetInteger("Specify the number of start beams (at least 2)")) < 3)
    ;

var d = ut.GetDistance(ptCenter, "Set the inner radius")
var D = ut.GetDistance(ptCenter, "Set the outer radius")
var da = Math.PI * 2 / n;
var hd = da / 2;

for (i = 0; i < n; ++i) {
    var a = da * i;
    var pt1 = ut.PolarPoint(ptCenter, a - hd, d)
    var pt2 = ut.PolarPoint(ptCenter, a, D)
    var pt3 = ut.PolarPoint(ptCenter, a + hd, d)
    ms.AddLine(pt1, pt2);
    ms.AddLine(pt2, pt3);
}

function ptDump(ut, pt)
{

```

By default, the editor opens with an empty text field. When saving to a file later, specify a particular script format from the list of available ones.

You can make it so that when you call the script editor, the last script edited in it automatically opens. To do this, set the option to automatically open the last script in the ScriptEd options dialog of the script editor, described below.



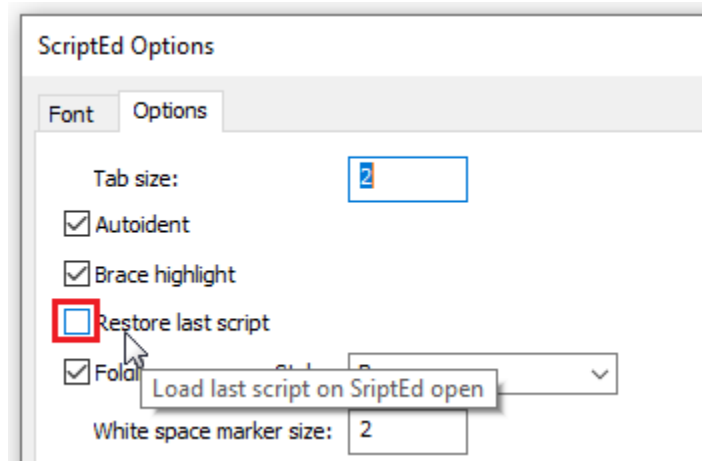

## Buttons



**New File.** Select the type of script in the drop-down menu.



**Open Script.** When you click on the button while holding down **CTRL** key, a menu will appear with the list of the most recently opened scripts and folders.

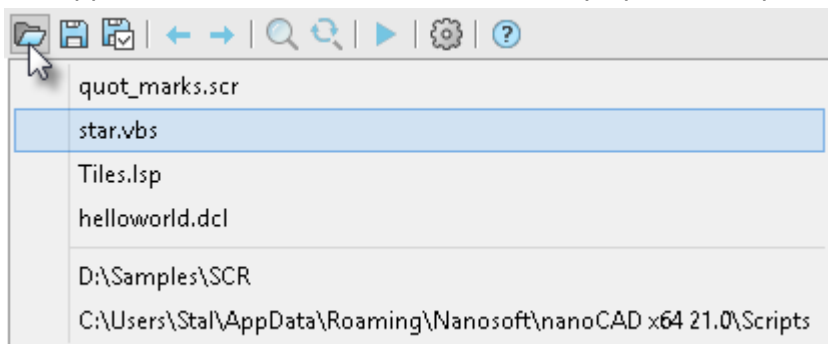

**Save Script.**



**Save As.**



**Undo.**



**Redo.**



**Find Text.** Opens the collapsed **Search and Replace** bar.



**Replace Text.** Opens the expanded **Search and Replace** bar.



**Run Script.**



**Options.**



**Help.**

## Options

The  button opens the scrip editor dialog box. The options dialog can also be opened by combination of **CTRL+T** buttons in the process of editing the script code. In this case, the cursor should be in the text field of the script editor.

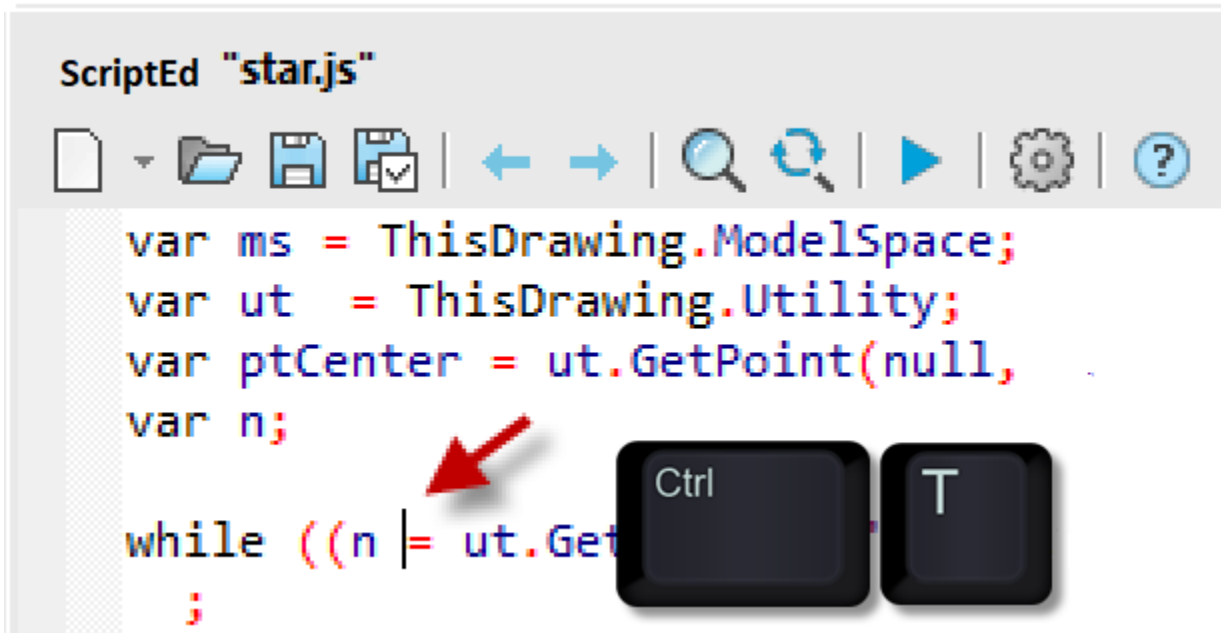

The **Font** tab of the **Options** dialog allows you to configure font settings for each category of a specific programming language.

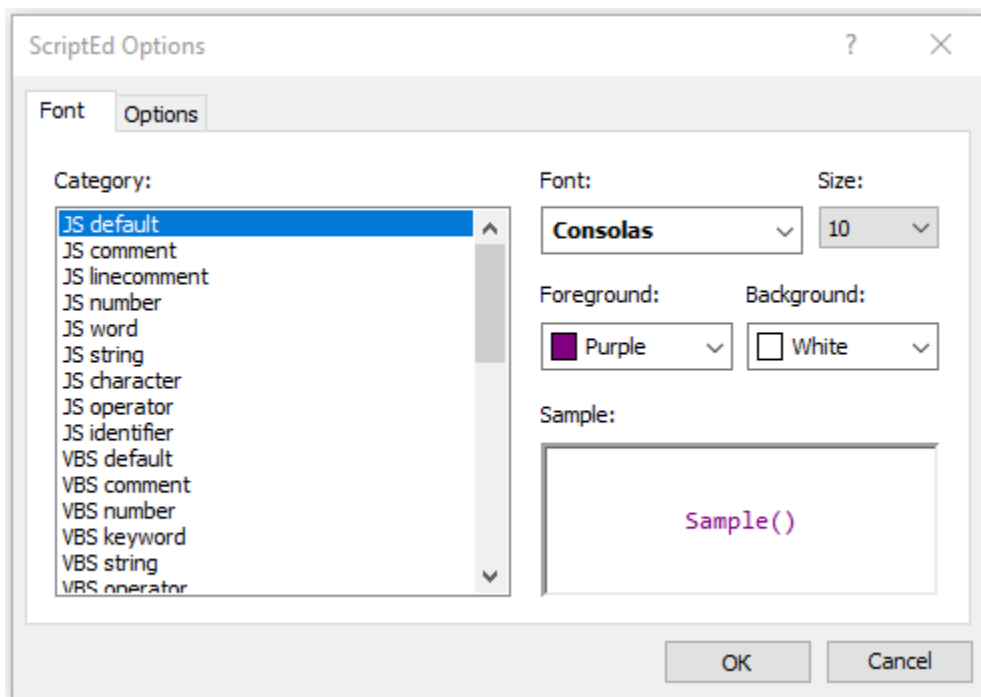

The **Options** tab allows you to configure general options for displaying the code in the edit window.

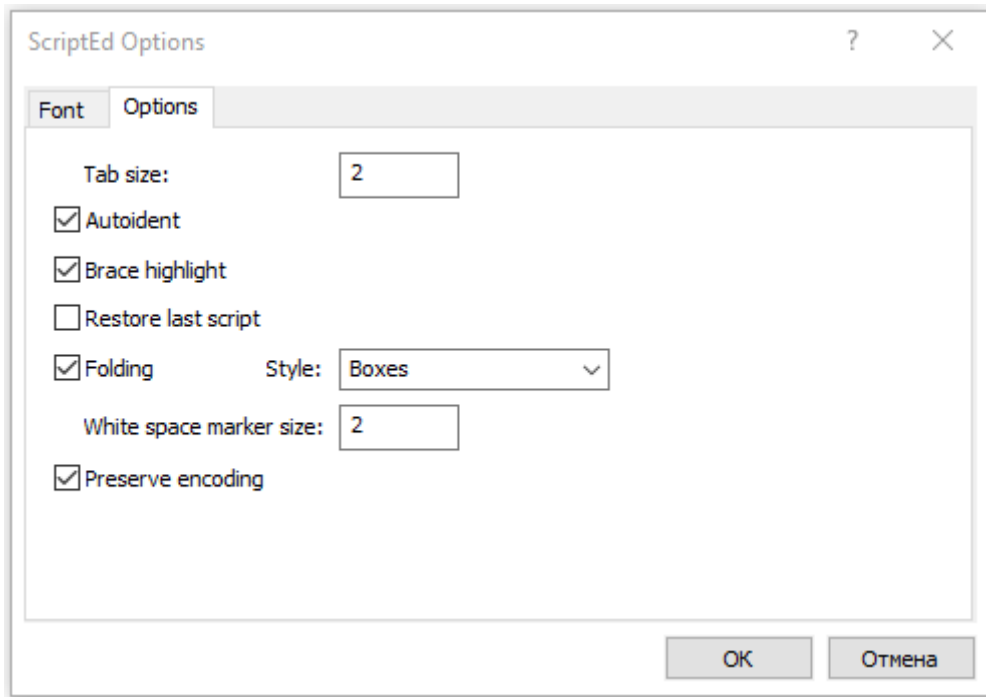

**Options:**

- Tab size**            Tab Size in spaces: the number of spaces to be inserted into a line when the **TAB** button is pressed on the keyboard.
- Autoindent**        Enables/disables automatic indentation of a new code line identically to the indentation of the previous line.
- Brace highlight**    Highlighting the opening and corresponding to it closing brackets when the cursor is on one of them.

```
(start_list "list" 2)
(add_list (get_tile "edit"))
(end_list)
```
- Restore last script**    Automatic loading of the latest script when opening the editor.
- Folding**            Enables/disables the text-block folding node. Text blocks are detected automatically.

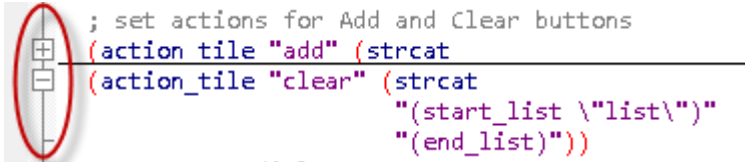

```
; set actions for Add and Clear buttons
(action_tile "add" (strcat
(action_tile "clear" (strcat
"(start_list \"list\\")
"(end_list)\")"
...))
```
- Style**              Folding Node Style: Arrows, Plus/Minus, Circles, Squares.
- White space marker size**    The size of the white space marker in pixels. To enable the display of the space character, press **CTRL+W** on the keyboard.

```
var ms = ThisDrawing.ModelSpace; CRLF
var ut = ThisDrawing.Utility; CRLF
var ptCenter = ut.GetPoint(null, "Specify the center of the star"); CRLF
var n; CRLF
CRLF
while ((n = ut.GetInteger("Specify the number of start beams (at least 2)")) < 3)
..; CRLF
CRLF
var d = ut.GetDistance(ptCenter, "Set the inner radius"); CRLF
var D = ut.GetDistance(ptCenter, "Set the outer radius"); CRLF
```

### Preserve encoding

Preserves the original encoding of the script file.

By default, the script editor uses UTF-8 encoding. All new scripts created in the script editor will have this encoding.

When opening a script file in the script editor, the encoding is determined automatically. If the **Preserve encoding** box is checked, then the script will be saved after editing in the same encoding it was in before opening in the script editor. If the checkbox is cleared, then the script will be saved in ANSI encoding (the current user encoding) after editing.

## Find and Replace in Scripts

The script editor has several tools to quickly find the right part of the code:

- [Find and replace bar](#);
- [Bookmarks](#);
- Panel for jumping to a line by its number.

### Find and Replace Bar

To search for text in scripts, you can open the search bar in one of the following ways:

- By clicking the  **Find text** button in the script editor;
- By the **CTRL+F** keys combination on the keyboard. In this case, the cursor must be in the text field of the script editor.

The search bar will appear at the bottom of the script editor below the script text edit field:

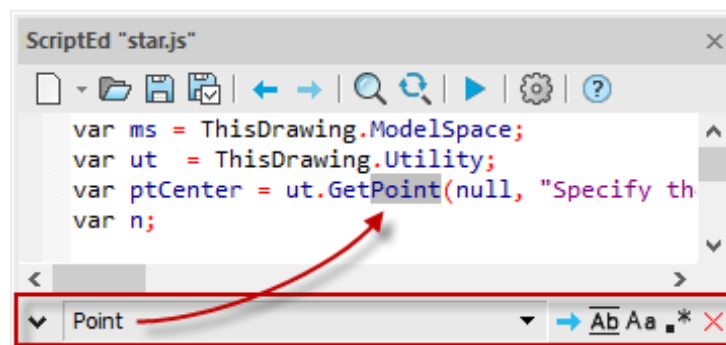

Find/replace mode switch button. When you click on the button, additional fields are opened for setting up the replacement of the found text. Clicking again hides additional fields.



Search pattern input field. You can enter single text characters, character sets, and regular expressions in the field. When you click on the  button located in the right part of the field, this opens a list of the latest requests entered.



Find next. Pressing the button moves the cursor to the next match of the script text with those entered in the search pattern input field.



[Use](#) regular expressions. Regular expressions will be used to search for text in the script.



Match case. The search will take into account the case of the characters entered in the pattern field.





Match whole word. The search results will only display exact matches with the text entered in the search pattern field.



Close the bar.

To automatically replace text in a script, open the replacement bar in one of the following ways:

- By clicking the  **Replace text** button in the script editor;
- By the find/replace mode switching button  on the search bar;
- By the **CTRL+H** key combination on the keyboard.

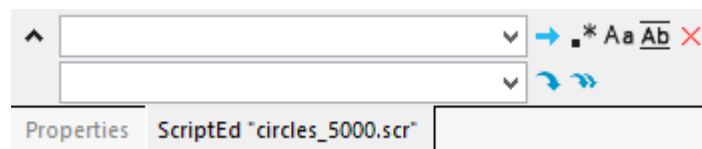

Elements of replacement bar to set the text replacement:

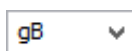

Replacement pattern input field. The field is intended for the text with which you want to replace the found text according to the pattern from the text search field. Clicking on the  button on the right side of the field opens a list of the most recently entered replacement patterns.



Replace. Clicking the button replaces the found text in the current fragment of the text file.



Replace all. Clicking the button replaces all matches found in the text file that match the text search pattern with the text specified in the text replacement pattern.

## Regular Expressions

A regular expression is a text search pattern that uses special characters to search for multiple spellings of an expression in a single search query.

To search for text in scripts using regular expressions, click the  **Regular expressions** button on the search bar. Repeated clicking the button disables regular expression search.

The following special regular expression characters are allowed:

- Replaces any character.  
For example, the expression `Layout..` will find all entries of the format `Layout01,Layout02, Layoutaa`, etc. in the script.
- \ Escapes the character following it from being read as a special character.  
For example, the expression `Layout\...` will find in the script all entries of the format `Layout.01, Layout.02, Layout.aa`, etc., that is, the dot character after `Layout` will not be recognized as a special replacement for any character.
- [ Inside square brackets, a set of options is specified, either as single characters or as ranges. It is not necessary to separate options with a space. When specifying a range, the start and end values are separated by a – sign.  
For example, the expression `[1-9]` will find in the script all the numbers from 1 to 9, the expression `[a-z]` will find in the script all the characters from `a` to `z`, and the expression `[ab1]` will find in the script individual characters either `a`, or `b`, or a number `1`.
- \* Applied to a character in the text and says that this character can either be absent or repeated from one to several times.  
For example, the expression `Layout0*` will find entries of the form both `Layout1`

and `Layout01`, `Layout001`, etc.

- + Applied to a character in the text and says that this character can be repeated from one to several times.  
For example, the expression `Layout0+` will find entries of the format `Layout01`, `Layout001`, etc.
- ? Applied to a character in the text and says that this character can either be absent or repeated only once.  
For example, the expression `Layout0?.` will find in the text records of the forms `Layout1`, `Layout01`.
- ^ Negative symbol. Applies to the character to be excluded from the search results.  
For example, the expression `Layout.[^a-z]` will find all entries in the script that contain the word `Layout`, followed by any character, and then any character other than the English letters from `a` to `z`.
- \$ End of line character. Applied at the end of the regular expression so that nothing extra is included in the search results.  
For example, the expression `Layout.[^a-z]` will show `Layout001` as a search result that matches the conditions, despite the fact that there is an extra character - `1` at the end. The expression `Layout.[^a-z]$` will not include this entry in the search results.

More information about regular expression syntax can be found [here](#).

## Bookmarks

To move quickly between lines, you can use bookmarks. Bookmarks are displayed as red flags on the left vertical bar of the script editor window next to the corresponding lines of code:

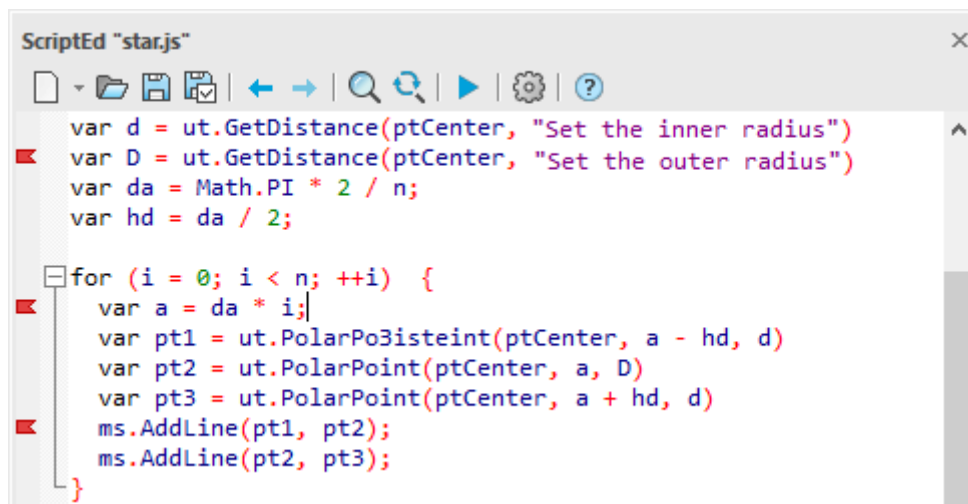

```

ScriptEd "star.js"
var d = ut.GetDistance(ptCenter, "Set the inner radius")
var D = ut.GetDistance(ptCenter, "Set the outer radius")
var da = Math.PI * 2 / n;
var hd = da / 2;

for (i = 0; i < n; ++i) {
    var a = da * i;
    var pt1 = ut.PolarPo3isteint(ptCenter, a - hd, d)
    var pt2 = ut.PolarPoint(ptCenter, a, D)
    var pt3 = ut.PolarPoint(ptCenter, a + hd, d)
    ms.AddLine(pt1, pt2);
    ms.AddLine(pt2, pt3);
}

```

You can bookmark a line in two ways:

- by clicking the left mouse button on the bookmarks bar opposite the required line;
- by placing the cursor on the required line and pressing the **CTRL**+**F2** key combination on the keyboard.

You can delete a bookmark in the same ways:

- by clicking the left mouse button on the bookmark flag;
- by placing the cursor on the line with a bookmark and pressing the **CTRL**+**F2** key combination on the keyboard.

You can delete all bookmarks at once by pressing **CTRL**+**L**.

To quickly jump between lines marked with bookmarks:

- to go to the next tab, press **F2** on the keyboard
- to go to the previous bookmark, press **SHIFT+F2**.

## Move to a Line by Number

To move to a script line by its number, open the corresponding bar in the script editor by pressing **CTRL+G** on the keyboard.

The bar will appear at the bottom of the script editor:

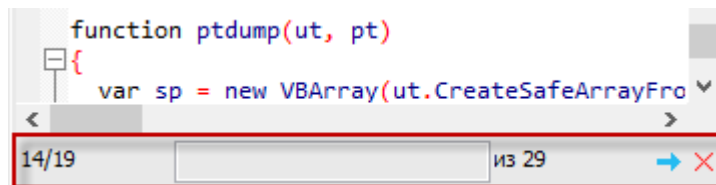

The bar elements:

14/19

The field shows which line the cursor is on.

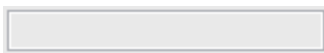

A field for entering the number of the line to move to.

из 29

The total number of lines in the script.



Button to move to the desired line.



Close the bar.

## Shortcuts

Many actions in the Script Editor are available through keyboard shortcuts. However, they work only during script editing, that is, when the cursor is in the script editing text field.

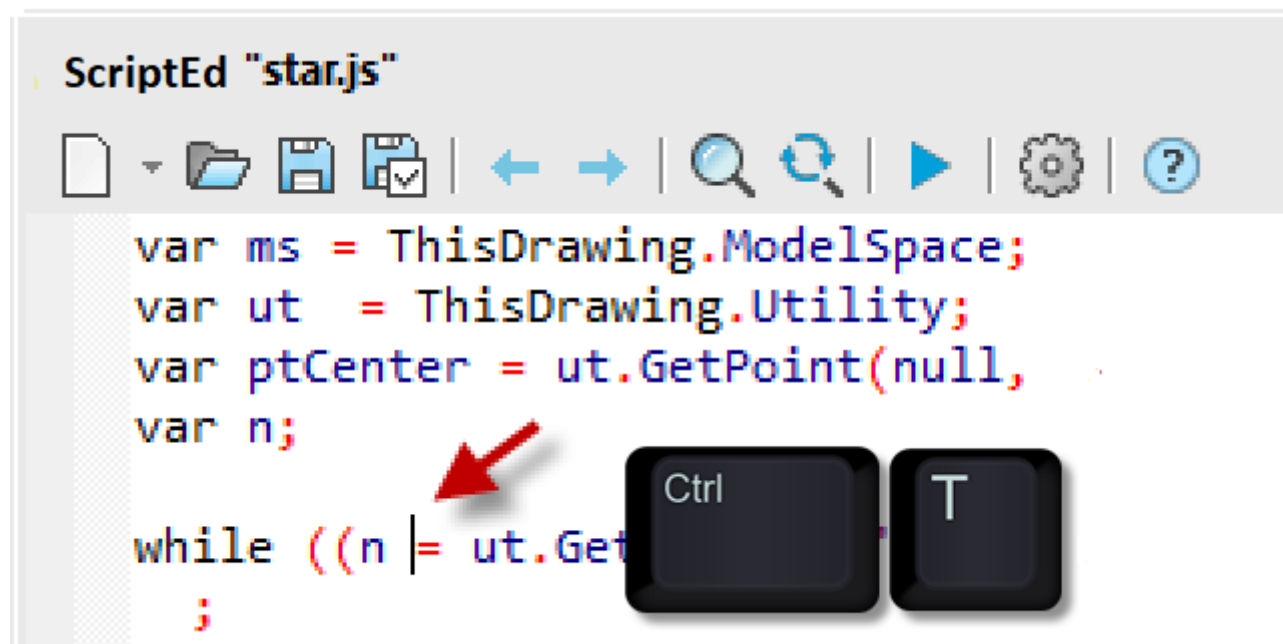

Select All

**CTRL+A**

Copy	<b>CTRL+C</b> , <b>CTRL+INS</b>
Insert	<b>CTRL+V</b> , <b>SHIFT+INS</b>
Cut	<b>CTRL+X</b> , <b>SHIFT+DEL</b>
Undo	<b>CTRL+Z</b> , <b>ALT+BACKSPACE</b>
Redo	<b>CTRL+Y</b>
Go to String	<b>CTRL+G</b>
Find	<b>CTRL+F</b>
Find Next	<b>F3</b>
Find Selected	<b>CTRL+F3</b>
Replace	<b>CTRL+H</b>
Open	<b>CTRL+O</b>
Save	<b>CTRL+S</b>
Save As	<b>CTRL+ALT+S</b>
Properties	<b>CTRL+P</b>
Run	<b>CTRL+R</b>
Find the Matching Pair Bracket	<b>CTRL+{</b>
Display/hide space characters	<b>CTRL+W</b>
Set/unset bookmark in the line	<b>CTRL+F2</b>
Move to the next bookmark	<b>F2</b>
Move to the previous bookmark	<b>SHIFT+F2</b>
Delete all bookmarks	<b>CTRL+L</b>



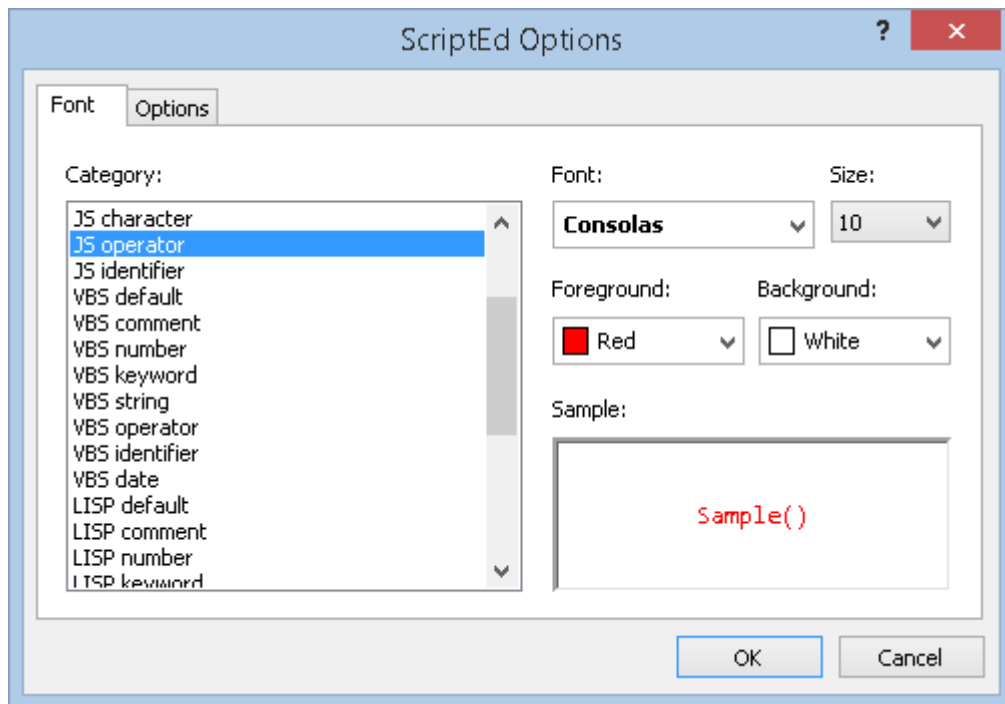

In the same dialog, you can also configure general options for displaying the code in the edit window.

## Creating Commands from Downloadable Applications and Command Scripts

Commands of the third-party applications, scripts, scenarios, etc. discussed above can be integrated into nanoCAD as independent commands. They can be placed in the ribbon, on toolbars, in the menu.

To do this:

1. Add the desired script/application in the autoload list using the **Application Load** (APPLOAD) or **Load NET Application** commands. For example, add **LispExample.lsp** with the following LISP command:

```
//LispExample.lsp
(defun c:SetColor()
  (command "_-Color" "230")
)
```

2. Create a new custom nanoCAD command in the **Customize user interface** dialog box based on SetColor command from the loaded

script/application. In the same place, specify the icon file for it.

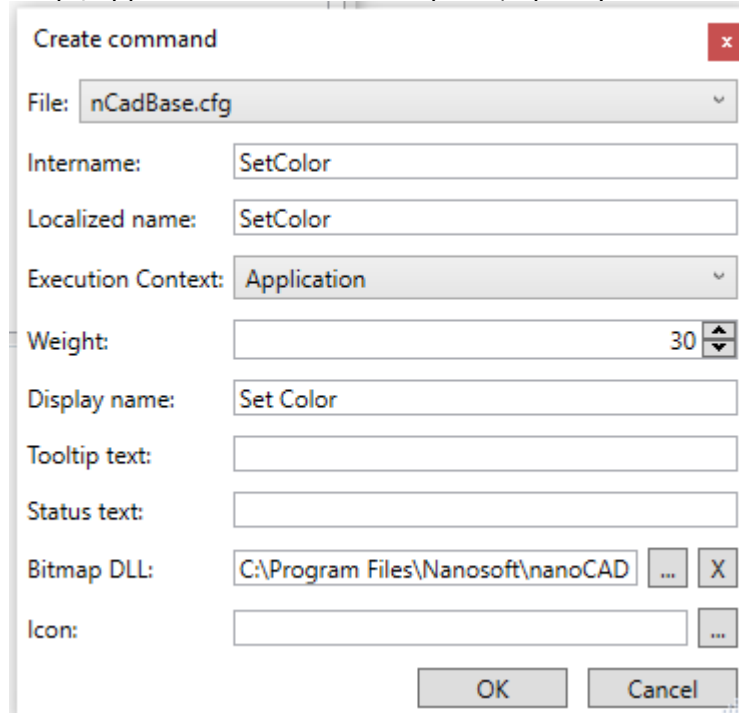

3. If necessary, create a new toolbar in the **Customize user interface** dialog.
4. In the same dialog, drag a newly created nanoCAD command to the required toolbar, menu or ribbon tab.



5. Reload nanoCAD.

## Run nanoCAD from Command Line with Program Module

There is a possibility to load a program module or extension script together with nanoCAD launch from the command line of the operating system or by using a shortcut.

Syntax of call from the command line:

```
<path>/ncad.exe [<path>/drawing file] [-invisible] [-s <path>/script file] [-g <path>/application file]
```

File names and paths that contain spaces should be enclosed with double quotation marks. For example:

```
"C:\Program Files\Nanosoft AS\nanoCAD x64 Plus 10.5\ncad.exe"  
"C:\Users\Alex\AppData\Roaming\Nanosoft AS\nanoCAD x64 Plus 10.5\Samples\ncad  
Mechanica.Shift.dwg"
```

Script file or file of loaded application should be the most recent parameter in the call line.

**NOTE:** Ways to launch nanoCAD from the command line of the operating system with the simultaneous opening of the desired document on the desired layout or with the required named view are discussed in the [Opening document from the command line](#) section.

### Options:

- |            |  |
|------------|--|
| -invisible | nanoCAD launch in a stealth mode. It creates only nanoCAD process. Nether window, nor program message are displayed on the screen. It is convenient to use at simultaneous load of script of loaded module to fulfill operation in the background. |
| -g         | Loading program module.  |
| -s         | Loading command script (*.scr).  |

Example of loading a drawing file and LISP-script in the background:

```
"C:\Program Files\Nanosoft AS\nanoCAD x64 Plus 10.5\nCad.exe"  
"C:\Users\Alex\AppData\Roaming\Nanosoft AS\nanoCAD x64 Plus 10.5\Samples\nCAD  
Mechanica. Shift.dwg" -invisible -g "C:\modules\plot_pdf.lsp"
```

Example of loading a command script:

```
nCad.exe -s "C:\modules\my settings 3.scr"
```

# INDEX

---

- \*.dwt, 71
- :Point Clouds
  - DBMS, 1347
- 2D Constraints, 1268
- 2D Projection, 1264
- 2D Section, 1265
- 2D Sketch, 1057, 1060, 1061, 1062, 1065, 1068, 1069
- 2D View, 1261
- 2D views, 1052
- 2D Wireframe, 365
- 3D, 1049, 1052, 1053, 1057, 1060, 1061, 1062, 1065, 1068, 1069, 1074, 1077, 1080, 1087, 1089, 1091, 1094, 1095, 1098, 1100, 1103, 1105, 1107, 1110, 1112, 1115, 1118, 1120, 1127, 1128, 1130, 1131, 1133, 1134, 1135, 1203, 1207, 1209, 1211, 1214, 1217, 1224, 1230, 1231, 1232, 1234, 1250, 1251, 1253, 1261, 1264, 1265
- 3D Align, 1203
- 3D Block Editor, 619
- 3D Chamfer, 1221
- 3D Extrude, 1069
- 3D Face, 1047
- 3D Fillet, 1220
- 3D History, 1053
- 3D Loft, 1080
- 3D Mesh, 1046
- 3D Mirror, 1227
- 3D Module, 1048
- 3D Move, 1207
- 3D Navigation, 322
  - Orthogonal View, 325
  - Perspective, 325
- 3D Orbit, 322
- 3D Polar Array, 1217
- 3D Polyline, 472
- 3D Rectangular Array, 1214
- 3D Revolve, 1074
- 3D Rotate, 1209
- 3D Scale, 1211
- 3D Settings, 1049, 1052, 1053
- 3D Solids, 1087, 1089, 1091, 1094, 1095, 1098, 1100, 1103, 1105
- 3D Solids Edit, 1107, 1110, 1112, 1115, 1118, 1120, 1127, 1128, 1130, 1131, 1133, 1134, 1135
- 3D Sweep, 1077
- 3D. Pseudo section properties, 1053
- 3D-Fly, 326
- 3D-Navigation
  - Free Orbit, 324
  - View Cutting Planes, 329
- 3D-Walk, 328
- Accelerators, 197
- Actions on Sheet Set and its Elements, 1622
- Add assembly sketch, 1060
- Add Measurement File, 1544
- Add planar sketch, 1057
- Add projection to sketch, 1062
- Add work axis, 1235
- Add work plane, 1234
- Add work point, 1237
- Adding Objects to the Working Set, 647
- Advanced Grips for Design Elements, 954
- Align, 586
- Align Viewport Objects, 1565
- Aligned, 1285
- Aligned Dimensioning, 878
- Aligning UCS to an Object, 257
- Angle 3D Constraint, 1242
- Angular, 1296
- Angular Dimensioning, 893
- API, 1628
  - Run from Command Line, 1642
  - Run in Conceal Mode, 1642
- Append Leader, 953

- Application Look, 69
- Arc, 484
  - by Center, Angles and Radius, 490
  - by Center, Start and Angle, 490
  - by Center, Start and Chord Length, 489
  - by Center, Start and End, 485
  - by Continue, 486
  - by Start Radius and Tangent, 489
  - by Start, Center and Angle, 487
  - by Start, Center and Chord Length, 487
  - by Start, Center and End, 486
  - by Start, End and Angle, 487
  - by Start, End and Direction, 488
  - by Start, End and Radius, 488
  - by Three Points, 485
- Editing, 533
- Length Dimensioning, 895
- Arrays, 562
  - 2D Array, 573
  - 3D Array, 578
  - Associative, 562
  - Edit, 570
  - Path Array, 568
  - Polar, 566
  - Rectangular, 562
- Associative Arrays, 562
- Attach Geounderlay, 1546
- Attributes of a Block
  - Creating, 622
- Audit Geometry, 123
- Auditing of Document, 122
- Auto constrain, 1305
- Autosaving Document, 88
- Background Mask for Multiline Text, 830
- Backup Copy, 89
- Base Dimensioning, 887
- Batch File Processing, 134
- Batch Plot, 1592
  - Features, 1598
- Bead, 1193
- Bend, 1180
- Bend along edge, 1152
- Bend along line, 1163
- Bend by sketch, 1159
- Big Radius Dimensioning, 892
- BIN, 1354
- Bind External References, 661
- Binding Named Objects of external References, 662
- Binding Objects, 667
- Block
  - 3D Block Editor, 619
  - Block Attribute Manager, 628
  - Editing Block Attribute Definitions, 632
  - Editing Block Reference Attributes, 626
  - Exploding, 636
  - Managing Blocks, 636
  - Reset, 636
  - Saving in a Separate File, 637
- Block Attribute Manager, 628
- Block Attributes, 621
- Block Reference Editor, 626
- Blocks, 610
  - Attributes, 621, 622
  - Editing, 616
  - Inserting, 613
  - Redefining, 615
  - Showing Boundary, 675
- Blocks Editor, 616
- Blocks in the Sheet Sets, 1621
- Boundary, 672
  - Creating, 813
  - rectangular, 677
  - Underlay, 682
- Bounding Prism, 348
- Bounding Prism by Object, 353
- Box, 1038, 1087
- Break All Vectors at Point, 549
- Breaking, 547
  - Dimensions, 903
  - Vectors, 547

- Vectors at a Point, 549
- Bring Forward, 344
- Bring to Front, 344
- CAD Standards, 108
  - Association with a Document, 109
  - Check Options, 114
  - Checking, 111
  - Creating, 108
- CAE Fidesys, 103
- Calculator, 1027
- Calibration, 727
- Callout Blocks, 1622
- Cartesian Coordinates, 251
- Cell Properties Dialog Box, 977, 984
- Chain Dimensioning, 888
- Chain Note, 950
- Chamfer, 589
- Chamfer edge, 1134
- Change Object Properties Command, 380
- Change Text Case, 866
- Change to Current Layer (Tools to Work with Layers), 441
- Changing
  - the UCS Position from the Command Line, 255
- Changing
  - External Reference to the Raster Image, 657
- Changing Image Resolution, 718
- Changing Object Properties from the Command Line, 380
- Changing UCS Position
  - New UCS by 3 Points, 260
- Changing UCS Position, 255
  - Changing Direction of Z-Axis in UCS, 260
  - New UCS View, 259
- Changing UCS Position
  - Rotating UCS Around X, Y or Z Axes, 261
- Checking Performance of Video Subsystem, 175
- Circle, 491
  - by Center and Diameter, 492
  - by Center and Radius, 491
  - by Diameter, 493
  - by Three Points, 493
  - by Two Tangents and Radius, 492
- Classifier, 1491
- Clip
  - Invert, 674
  - Map Underlay, 695
- Clip Borders
  - Show, 673
- Clip Clouds by Cylinder, 1380
- Clip Clouds by Sphere, 1379
- Clip Invert, 1383
- Clip Point Cloud, 1376
- Clip Point Clouds by 2 Points, 1377
- Clip Point Clouds by 3 Points, 1378
- Clip Point Clouds by Fence, 1378
- Clipboard
  - Copy, 523
  - Copy OLE-Link, 524
  - Copy with Base Point, 523
  - Cut, 523
  - Paste, 524
  - Paste as Block, 525
  - Paste as Raster, 525
  - Paste Special, 526
  - Paste to Original Coordinates, 526
- Closing a Document, 83
- Closing corners, 1170
- Coincident, 1269
- Collinear, 1271
- Color, 396
- COM, 1628
- Comb Leader Note, 940
- Command line, 51
  - command input, 52
- Command Line
  - Auto Hide, 57
  - Data Format, 55
  - Mathematical Processor, 55

- Select Options, 54
- Text Window, 54
- Command Scripts (SCR), 1628
- Commands
  - Non-dialog Mode, 59
  - Recall, 60
  - Transparent Mode, 59
- Common settings, 1049
- Compare .dwg files, 141
- Concentric, 1279
- Cone, 1040, 1091
- Configurations of Layers, 420
- Configuring Connections to the DBMS, 1350
- Constraint settings, 1306
- Construction Line, 468
- Construction Note, 938
- Control the Objects Visibility, 345
- Controlling Grid Options from the Command Line, 278
- Conventional signs
  - adding line signs, 1495
- Conventional Signs, 1491
  - Adding Point Signs, 1494
  - Adding to the Library, 1494
  - Creating Customized Library, 1493
  - Editing Existing Signs, 1496
  - Library Structure, 1493
- Convert Field to Text, 874
- Convert to 2D, 129
- Convert to Mesh, 1250
- Convert to Solid, 1251
- Converting Block Attributes to Text, 635
- Converting PDF Underlay, 96
- Converting Tables, 984
- Converting to Meshes or 3D Faces, 1442
- Coordinate Filters, 254
- Coordinate System
  - Specifying Direction-Distance Points, 253
- Coordinate systems, 251
- Coordinate Systems
  - Cartesian Coordinates, 251
  - Coordinate Filters, 254
  - Dynamic UCS, 261
  - New Origin and Rotation Angle for UCS, 259
  - New Origin for UCS, 259
  - Orthographic UCS, 268
  - Polar Coordinates, 252
  - UCS Settings, 270
  - User Coordinate System, 254
  - World Coordinate System, 255
- Copy, 523, 557
- Copy Objects to New Layer (Tools to Work with Layers), 442
- Copy of Objects Properties, 520
- Copy OLE-Link, 524
- Copy with Base Point, 523
- Copying a Clip to the Selected View, 1383
- Copying and Insertion of Objects Using Clipboard, 522
- Correct displaying of a large drawings, 179
- Correction by 4 Points, 724
- Coverings, 1315
  - Coverings Browser, 1316
  - Coverings Editor, 1319
  - Coverings Library, 1318
  - Texture Editor, 1321
- Coverings Browser, 1316
- Coverings Editor, 1319
- Coverings Library, 1318
- Create a Cloud Based on Clipping, 1359
- Create a Cloud from View, 1359
- Create Layer (Tools to Work with Layers), 438
- Create New Command, 204
- Create New Raster Image, 711
- Create Sheet Set, 1606
- Creating, 465
  - 3D Face, 1047
  - 3D Mesh, 1046
  - 3D Polyline, 472
  - Arc, 484
  - Block Attributes, 622

- Boundary, 813
- Box, 1038
- Circle, 491
- Cone, 1040
- Construction Line, 468
- Custom Properties Fields, 381
- Dimensions, 876
- Dish, 1044
- Dome, 1045
- Donut, 494
- Ellipse, 497
- Ellipses and Elliptic Arcs with One Command, 500
- fill, 797
- Group of Layers, 416
- group of objects, 607
- Hatch, 797
- Helix, 501
- Layers Filters, 417
- Layout, 1551, 1552
- Layout Viewports, 1560
- Layouts by Frames, 1540
- Line, 469
- Mesh, 1046
- New Document, 71
- New Linetype, 459
- Note, 934
- Point, 465
- Polygon, 478
- Polyline, 470
- Pyramid, 1042
- Ray, 467
- Rectangle, 479
- Region, 814
- Reports, 1002
- Revision Cloud, 817
- Solid, 815
- Sphere, 1041
- Spline, 495
- Table, 960
- Text, 819, 822
- Text Style, 850
- Torus, 1042
- Viewport, 1560, 1561, 1562
- Wedge, 1039
- Wipeout, 816
- Creating a Group of Geopoints Manually, 1425
- Creating a Multileader, 925
- Creating a New Document by Template, 73
- Creating a Standards File, 108
- Creating Arc Text, 847
- Creating Commands from Downloadable Applications and Command Scripts, 1641
- Creating Customized Library of CS, 1493
- Creating Frames, 1536
- Creating Geopoints by Interpolation, 1416
- Creating Geopoints by Points and Texts, 1414
- Creating Geopoints by Surface, 1416
- Creating Geopoints Manually, 1413
- Creating Groups of Geopoints by Original Description, 1426
- Creating Label Styles of Geopoints, 1426
- Creating Layers, 407
- Creating Marker Styles of Geopoints, 1427
- Creating PC3 File, 1578
- Crop Raster Auto, 720
- Crop Raster Auto by Clip, 721
- Crop Raster Auto by Frame, 721
- Crop Raster by Rectangle, 721
- Cropping of Raster Image, 720
- Current Layer, 409
- Current UCS, 328
- Cursor Size, 298
- Custom Paper Formats, 1579
- Custom Properties Fields, 381
- Custom Properties of the Sheet Set, 1619
- Customize Dialog Box
  - Profiles Tab, 171
- Cut, 523
- Cyclone PTX, 1355
- Cylinder, 1089



- DCL-Editor, 1632
- Delete constraints, 1308
- Delete Layer (Tools to Work with Layers), 450
- Deleting Duplicates, 580
- Deleting Frames, 1543
- Deleting Layout, 1555
- Design of Layouts, 1536
- Design Settings, 210
- Deskew a Raster, 723
- Detach Leader, 953
- Determining the Diameter, 1401
- Determining the Radius, 1400
- Diameter, 1294
- Diameter Dimensioning, 889
- Dimension Input, 301
- Dimension Styles
  - Creating, 905
  - Modifying, 908
- Dimensional constraint, 1298
- Dimensioning with a Single Command, 876
- Dimensions, 874
  - Aligned, 878
  - Angular, 893
  - Arc Length, 895
  - Base, 887
  - Big Radius, 892
  - Breaking, 903
  - Chain, 888
  - Creating, 876
  - Diameter, 889
  - Editing, 897
  - Exploding, 904
  - Features of Dimensioning in nanoCAD, 875
  - Group, 886
  - Horizontal, 878
  - Linear, 878
  - Offset Dimension, 896
  - Ordinate, 883
  - Radial, 891
  - Restoring, 904
  - Scale, 875
  - Styles, 905
  - Vertical, 878
- Dimensions to Front, 345
- DirectX, 174
  - Manual Adjustment, 177
  - Performance Checking, 175
- Discarding External Reference Changes, 648
- Dish, 1044
- Display All Cloud Points, 1361
- Display Modes, 308
- Display Order
  - Bring Forward, 344
- Display Order
  - Bring to Front, 344
  - Send to Back, 344
- Display Order
  - Send Backward, 344
- Display Order
  - Texts to the Front, 344
- Display Order
  - Dimensions to the Front, 345
- Display Order
  - Texts and Dimensions to the Front, 345
- Display Order
  - Hatches to the Back, 345
- Displaying a Point Cloud, 1376
- Distant Light, 1313
- Distributing
  - Copies, 587
  - Objects by Layers, 399
- Divide, 587
- Docked Document Window, 80
- Document
  - Auditing, 122
  - Autosaving, 88
  - Backup, 89
  - Closing, 83
  - Convert to 2D, 129

- Create by Template, 73
- Creating, 71
- Docked Window, 80
- Drawing Properties, 80
- Floating Window, 79
- Opening, 73
- Plotting, 1568
- Purging, 125
- Recovery, 125
- Saving, 83
- Text Encoding Conversion, 129
- Dome, 1045
- Donut, 494
- Download CAE Fidesys, 104
- Drafting modes
  - Display Elements Setting, 298
- Drafting Settings
  - Grid Options from the Command Line, 278
  - Object 3D Snap, 293
  - Point Cloud Snap Mode, 293
- Draw
  - Multiline, 473
- Drawing
  - Limits, 278
  - Shape, 812
  - Units, 239
- Drawing Comparison, 141
- Drawing Context, 1491
- Drawing Explorer, 384
- Drawing Properties, 80
- Drawing Regeneration, 375
- dwg Tables, 1014
  - Insert, 1014
- Dynamic Input, 300
- Dynamic Prompts, 306
- Dynamic UCS, 261
- E57, 1355
- Edit, 1032
  - 3D Array, 578
  - Grouping, 606
  - Polyline Segments, 540
- Edit Attribute In-Place, 632
- Edit Field, 873
- Edit Linetype, 455
- Edit Objects Geometry Commands, 541
- Edit planar sketch, 1068
- Editing
  - Arc, 533
  - Dimensions, 897
  - External Reference, 644
  - Fill, 538
  - Group of Layers, 417
  - Hatch, 538
  - Layers Filters, 418
  - Layout Viewports, 1563
  - Leader, 954
  - Line, 532
  - Notes, 952
  - objects, 503
  - Objects, 520, 557
  - Polyline, 533, 552
  - Simplify Spline, 556
  - Spline, 554
  - Tables, 967, 969
  - Text, 832, 840
  - the Size of Rows and Columns, 978
  - Viewports, 537
- Editing an Array, 570
- Editing Block Attribute Definitions, 632
- Editing Label Styles of Geopoints, 1427
- Editing Marker Styles of Geopoints, 1429
- Editing Properties of Geopoint Groups, 1430
- EDS, 1603
  - Creating External EDS File, 1604
  - Creating Internal EDS, 1603
  - Sign External File, 1604
- Eliminating Deformations of Raster Images, 761
- Ellipse
  - by Axis and Semi-axis, 498
  - by Semi-axes, 497

- Elliptic Arc, 499
- Elliptic Arc, 499
- Embed Raster Image, 712
- Embedding Objects, 667
- End editing, 1069
- Equal, 1281
- Erase, 557
- Exit from nanoCAD, 33
- EXPLODE Command, 601
- Explode Geometry, 601
- Explode Text, 865
- Exploding
  - Dimensions, 904
  - group, 607
  - Objects, 602
- Exploding a Block, 636
- Exploding Proxy Objects, 640
- Export
  - to CAE Fidesys, 103
  - to JT Format, 102
  - to Stereolithography Format, 100
- Export Geopoints, 1514
- Export Layout to Model, 1559
- Export Model for Sim4Design, 104
- Export of Point Clouds, 1346
- Export to GIS, 1526
- Export to LandXML, 1521
- Exporting, 98
  - All Data, 99
  - Selected Data, 100
  - Transmittal Package Creation, 104
- Exporting Cloud Data to DBMS, 1349
- Exporting User Interface Settings, 146
- Expression Builder
  - Formula Templates, 998
  - Functions, 999
- Expression Builder Dialog Box, 996
- Extend Vectors, 546
- Extenders, 1642
- External References
  - Adding Objects to the Working Set, 647
  - Bind Named Objects (Xbind), 662
  - Binding, 661
  - Changing to the Raster Image, 657
  - Discarding Changes, 648
  - Editing, 644
  - Inserting, 640
  - Manager, 648
  - Monitor, 664
  - Notifications, 664
  - Removing Objects from the Working Set, 647
  - Saving Changes, 647
  - Showing Boundary, 675
- External References Dialog Box, 648
- External References Monitor, 664
- External References Notification, 664
- Extract from View, 1358
- Extracting Data from Attributes, 634
- Extrude, 1107
- Faro XYB, 1357
- Fast Gradient, 810
- Fast Hatch, 810
- Feature Isolation Reset, 1391
- FEdit, 1033
- Fidesys, 103
- Field
  - Convert to Text, 874
  - Edit, 873
  - Update, 873
- Field Categories and Types, 870
- Field Dialog Box, 869
- Fields, 868
- File Explorer, 136
- Fill
  - Creating, 797
  - Editing, 538
  - Fast Gradient, 810
  - Gradient, 808
- Fillet, 595
- Fillet edge, 1133

- Filling and Hatch Commands, 797
- Finding and Replacing Text, 855, 860
- Fit Text, 865
- Fix, 1284
- Flanging, 1200
- Flatten SM, 1184
- Floating Document Window, 79
- Fly, 326
- Format
  - Multiline Styles, 474
- Formula Templates, 998
- Free Orbit, 324
- Freezing Layers, 409
- Freezing Layers in Viewports, 410
- Functions in the Expression Builder, 999
- Geopoint Groups, 1410
- Geopoints, 1406
  - by Points and Texts, 1414
  - Create Manually, 1413
  - Creating a Group, 1425
  - Creating Groups by Original Description, 1426
  - Creating Label Styles, 1426
  - Creating Marker Styles, 1427
  - Editing Label Styles, 1427
  - Editing Marker Styles, 1429
  - Editing Properties of Geopoint Groups, 1430
  - Export, 1514
  - Groups, 1410
  - Import, 1504
  - marker and label styles, 1409
  - User-Defined Properties, 1411
- Geopoints in the Drawing Explorer, 1408
- GIS, 1521, 1526
- Gradient Fill, 808
  - Fast, 810
- Graphic Subsystem, 173
- Graphic Subsystem Settings, 173
- Graphics Hardware Acceleration Settings, 174
- Grid mode, 274
- Grips
  - Advanced, 954
  - Multifunctional, 531
  - Ordinary, 528
- Group
  - Object Grouping Dialog, 606
- Group Dimensioning, 886
- Group of Layers, 416
  - Creating, 416
  - Editing, 417
- Grouping and Merging Cells, 1007
- Groups of objects
  - adding object, 608
  - creating, 607
  - deleting objects, 608
  - renaming, 609
- Groups of Objects, 603
- Hatch
  - Creating, 797
  - Creation, 804
  - Editing, 538
  - Fast, 810
  - Setting Layer, 811
- Hatch Dialog, 797
- Hatches to Back, 345
- Hatching Sections, 1267
- Helix, 501
- Help, 32
- Hide Objects, 347
- Hiding a Feature, 1385
- Hiding All Features, 1387
- Hiding Frames, 1542
- Hiding the Point Cloud, 1375
- Hole, 1173
- Horizontal, 1273, 1289
- Horizontal Dimensioning, 878
- Horizontal Section of Point Cloud, 1382
- Hyperlinks, 697
  - Add to the Document, 697

- Edit, 700
- Image Adjust, 713
- Image Quality, 715
- Images, 702
  - Adjust, 713
  - Cropping, 720
  - Displaying Quality, 715
  - Embed, 712
  - Inserting, 702
  - Separate, 711
  - Showing Boundary, 678
- Import from GIS, 1521
- Import from LandXML, 1520
- Import Geopoints, 1504
- Import Measurements, 1545
- Import of KML/KMZ files, 1535
- Import of Point Clouds, 1332
- Import PDF, 93
- Importing, 91
- Importing Cloud Data from DBMS, 1348
- Importing PDF Underlay Data, 96
- Importing User Interface Settings, 148
- Improved Compatibility Mode, 179
- In Place Edit, 1034
- Include object to sketch, 1061
- Incremental Saving, 91
- In-Place Attribute Editing, 632
- Inquiry, 1023
  - Area, 1021
  - List, 1022
- Insert 3D Constraint, 1240
- Insert OLE-Object, 668
- Inserting
  - Block, 613
  - External Reference, 640
  - Material, 1013
  - Raster Image, 702
  - Report Section, 1002
- Inserting Underlays, 670
- Installation of the Program, 31
- Integration with CAE Fidesys, 103
- Interface
  - Application Look, 69
  - Color Themes, 69
  - Customize, 180
  - Restore UI State, 68
- Interface of nanoCAD
  - command line, 51
  - Context Menu, 45
  - Drawing Window, 43
  - Main Menu, 40
  - Managing Elements, 68
  - nanoCAD Button, 36
  - Properties Bar, 46
  - Quick Access Toolbar, 37
  - Ribbon, 37
  - Status Bar, 65
  - Toolbars, 42
- Interfere 3D solids, 1105
- Internal PDF-Plotter, 1599
- Intersect, 1231
- Introduction, 29
- Invert Selection, 509
- Isolate Features, 1384
- Isolate Layer (Tools to Work with Layers), 443
- Isolate Objects, 347
- Isolating a Feature, 1387
- Isolating All Features, 1389
- Isometric Drafting, 371
- Isometric Views, 318
- Jalousie, 1190
- Jog, 1166
- Join Objects, 550
- JPG and JPEG Saving Options, 661
- JScript
  - Editor, 1632
  - Loading, 1630
- JS-Editor, 1632
- JT, 102
- Justification of the Text Objects, 833

- Justify Text, 861
- KML, 1535
- KMZ, 1535
- Label Blocks for Views, 1621
- LandXML, 1520, 1521
- LAS, 1353
- LAS Classification, 1353
- Launch of nanoCAD, 32
- Layer Manager, 400
- Layer Off (Tools to Work with Layers), 444
- Layer Previous (Layer Tools), 451
- Layer State Dialog, 422
- Layer States
  - Layer State Manager, 422
- Layer Walk (Tools to Work with Layers), 439
- Layers
  - Locking, 414
- Layers
  - Control, 405
  - Create, 407
  - Editing Parameters, 405
  - Freezing, 409
  - Freezing in Viewports, 410
  - Locking, 409
  - Making Current, 409
  - Redefinition of Properties, 412
  - Removal, 407
  - Renaming, 407
  - Visibility, 409
- Layers
  - Printable Layers, 414
- Layers
  - View Mode, 415
- Layers
  - Groups, 416
- Layers
  - Filters, 417
- Layers
  - Configurations, 420
- Layers
  - Tools, 437
- Layers Dialog Box, 400
- Layers Filters
  - Creating, 417
  - Editing, 418
- Layers Visibility, 409
- Layout, 1551
  - Copy without Viewport, 1554
  - Copying, 1553
  - Creating, 1551
  - Creating from a Template, 1552
  - Deleting, 1555
  - Renaming, 1556
  - Saving as a Template, 1554
- Layout Viewports
  - Creating, 1560
  - Editing, 1563
- Layouts
  - Managing from the Command Line, 1558
- Layouts
  - Export Layout to Model, 1559
- Layouts
  - Change Space, 1567
- LAZ, 1354
- Leader
  - Multileader, 925
- Leaders
  - Appending, 953
  - Detaching, 953
  - Editing, 954
- Leave in Selection, 508
- Leica PTX, 1355
- Lengthen Objects, 541
- LiDAR, 1353
- Light Sources, 1309
  - Distant Light, 1313
  - Point Light, 1309
  - Spotlight, 1311
  - Weblight, 1314
- Line, 469

- Creating, 469
- Editing, 532
- Line Types, 451
- Line weight, 338
- Line Weight
  - Settings, 338
- Linear, 1287
- Linear Aligned Note, 948
- Linear Dimensions, 878
- Linetype Manager, 451
- Lineweight Settings Dialog, 338
- LISP, 1628
  - Command, 1631
  - Commands, 1631
  - Editor, 1632
  - Load, 1631
  - Loading, 1629
- Locator, 332
- Lock Layer (Tools to Work with Layers), 449
- Locking Layers, 409, 414
- Loft, 1112
- LSP-Editor, 1632
- Main Menu, 190
- Make Object's Layer Current (Tools to Work with Layers), 439
- Managing
  - Interface Elements, 68
  - Named Viewports, 360
  - Named Views, 339
  - Transparency of Objects, 464
- Managing Blocks, 636
- Managing Layouts from the Command Line, 1558
- Managing Point Cloud Revisions in the DBMS, 1353
- Manipulators, 1206
- Map Underlay, 684
  - Clip, 695
  - Load, 696
  - Unload, 695
- Marker and Label Styles of Geopoints, 1409
- Mass Properties of 3D-Solids and Regions, 1025
- Match Layer (Tools to Work with Layers), 440
- Mate 3D Constraint, 1238
- Measure, 588
- Measurement Archive, 1543
- Measurement Scale, 246
- Measurements Archive
  - Add Measurement File, 1544
  - Attach Geounderlay, 1546
  - Import Measurements, 1545
  - Save as Geounderlay, 1547
  - Save to Measurement Archive, 1545
- Measuring Distance and Angles, 1020
- Mechanical Note, 934
- Merge, 767
- Merge a Copy, 768
- Merge Layer (Tools to Work with Layers), 450
- Mesh, 1046
- Mesh Optimization, 1445
- Migration of Settings, 145
- Mirror, 559
- Mirror a Raster, 722
- Mixed Type Sheet Set, 1615
- MLine Styles, 474
- Model Space, 1548
  - Batch Plot, 1598
- Model Viewports
  - 2 Viewports Horizontal, 354
  - 3 Viewports, 354
  - 4 Viewports, 356
- Model Viewports
  - 1 Viewport, 354
  - 2 Viewports Vertical, 354
- Model Viewports
  - 3 Viewports Horizontal, 355
- Model Viewports
  - 3 Viewports Vertical, 355
- Model Viewports

- 3 Viewports Left, 355
- Model Viewports
  - 3 Viewports Right, 356
- Model Viewports
  - 3 Viewports Top, 356
- Model Viewports
  - 3 Viewports Bottom, 356
- Modeling, 1069, 1074, 1077, 1080, 1087
- Modeling modes, 1056
- Modify
  - Align, 586
  - Array, 562
  - Chamfer, 589
  - Copy, 557
  - Copy Objects Properties, 520
  - Delete Duplicates, 580
  - Distributing Copies, 587
  - Erase, 557
  - Explode Geometry, 601
  - Fillet, 595
  - Mirror, 559
  - Move, 581
  - Offset, 560
  - Scale, 583
  - Stretch, 585
- Modifying
  - Dimension Style, 908
  - Hatched Areas, 811
- Modufy
  - Break All Vectors at Point, 549
- Move, 581
- MultiCAD API, 1628
- Multifunctional Grips
  - Editing 3D-Polyline, 536
  - Spline Editing, 535
- Multileader, 925
  - Adding Leader Lines, 927
  - Aligning, 927
  - Collecting, 928
  - Creating, 925
  - Modifying Style, 931
  - Removing Leader Lines, 927
  - Style Manager, 929
- Multiline, 473
  - Styles, 474
- Multiline Text, 822
- Named UCS, 266, 328
- Named Viewports, 357, 360
- Named Views, 339
- nanoCAD Button, 36
- nanoCAD NPC, 1357
- nanoCAD user interface, 35
- ncad.lsp, 1631
- NET, 1628
  - Loading, 1630
- New Command Creation, 204
- New Image, 711
- New Image from Selection, 705
- New Layout, 1551
- New Origin and Rotation Angle for UCS, 259
- New Origin for UCS, 259
- New Topoplan, 1403
- Node Note, 946
- Note for Multilayered Construction, 944
- Notepad, 1028
- Notes
  - Chain, 950
  - Comb Leader, 940
  - Construction, 938
  - Editing, 952
  - for Multilayered Constructions, 944
  - Linear Aligned, 948
  - Mechanical, 934
  - Node, 946
  - Section, 943
- NPC, 1357
- NRX, 1628
  - Load, 1631
  - Loading, 1629
- NSF, 1630



- Load, 1631
- Loading, 1630
- Object Actions, 199
- Object Snap Mode, 282
- Object Snap Tracking Mode, 295
- Objects
  - Custom Properties Fields, 381
  - Display Order, 343
  - Editing, 520, 528, 531, 557
  - Exploding, 602
  - Groups, 603
  - Joining, 550
  - Lengthen, 541
  - Managing Transparency, 464
  - Order, 343
  - properties, 377
  - Selecting, 503
- Objects Display Order, 343
- Objects Isolation, 345
- Offset, 560
- Offset Dimension, 896
- Offset edge, 1131
- OLE, 667
  - Binding and Embedding Objects, 667
  - Insert, 668
  - Open, 668
  - Update All Links, 669
  - Update Links, 669
- Open in FidesysBundle, 104
- Open OLE-Object, 668
- Open Sheet Set, 1612
- OpenGL, 174
  - Automatic Adjustment, 175
  - Improved Compatibility Mode, 179
  - Manual Adjustment, 177
  - Performance Checking, 175
- Opening a Document, 73
- Operators and functions, 1303
- Options Dialog Box, 149
- Options of Export to JT, 102
- Options of Export to STL, 100
- Order of Objects, 343
- Ordinate Dimensioning, 883
- ORTHO Mode, 299
- Orthogonal View, 325
- Orthographic UCS, 268
- Orthographic Views, 314
- Page Division Dialog Box, 980
- Page Setup, 1572
- Page Setup Manager Dialog Box, 1569
- Pan, 308
- Paper Space, 1548
- Parallel, 1275
- Parameters Manager, 1299
- Parameters Redefinition, 1034
- Paste, 524
- Paste as Block, 525
- Paste as Raster, 525
- Paste Special, 526
- Paste to Original Coordinates, 526
- Path Array, 568
- PC3 Files, 1578
- PCD, 1356
- PDF
  - Importing Underlay Data, 96
- Perpendicular, 1274
- Perspective View, 325
- Pixel Drawing on Raster, 768
- Plan, 328
- Plate, 1149
- PLOT Command, 1588
- Plot Preview, 1583
- Plot Style Manager, 1586
- Plotting
  - Saving plotter settings to PC3, 1578
- Plotting, 1588
  - Custom Paper Formats, 1579
  - Documents, 1568
  - Editing the List of Paper Formats, 1581
  - Page Setup, 1569, 1572

- Plot Style, 1586
- Preview, 1583
- PLY, 1357
- Point, 465
  - Creating, 465
  - Size and Style, 466
- Point Cloud
  - Clip Invert, 1383
  - Switch Boundary, 1361
- Point Cloud Display Settings, 1361
- Point Cloud Info, 1393, 1399
- Point Cloud Snap Mode, 293
- Point clouds
  - clip by 2 points, 1377
  - clip by 3 points, 1378
  - import, 1332
- Point Clouds, 1332
  - BIN Format, 1354
  - Clip, 1376
  - Clip by Cylinder, 1380
  - Clip by Fence, 1378
  - Clip by Sphere, 1379
  - Cloud Info, 1393
  - Configuring Connections to the DBMS, 1350
  - Copy a Clip to the Selected View, 1383
  - Create Based on Clipping, 1359
  - Create from View, 1359
  - Data Formats, 1353
  - Determining the Diameter, 1401
  - Determining the Radius, 1400
  - Display Settings, 1361
  - Display All Points, 1361
  - Display Settings, 1361
  - E57 Format, 1355
  - Export, 1346
  - Export Data to DBMS, 1349
  - Extract from View, 1358
  - Horizontal Section, 1382
  - Import Data from DBMS, 1348
  - LAS Format, 1353
  - LAZ format, 1354
  - NPC Format, 1357
  - PCD Format, 1356
  - PLY Format, 1357
  - Point Info, 1399
  - PTS Format, 1356
  - PTX Format, 1355
  - RCP Format, 1358
  - RCS Format, 1358
  - Recalculation of Geocoordinates by EPSG, 1360
  - Reset All Clips, 1381
  - Section, 1381
  - Snap to Features, 1362
  - Snap to Points, 1362
  - Supported File Formats, 1353
  - Transformation to Default Coordinates, 1359
  - TXT Format, 1357
  - Undo Clip, 1381
  - Unrestricted Section, 1382
  - Vertical Section, 1383
  - View Mode, 1363
  - XYB Format, 1357
  - XYZ Format, 1357
  - Zoom after Import, 1362
- Point Clouds Data Formats, 1353
- Point Clouds Section, 1381
- Point Coordinates, 1020
- Point Light, 1309
- Polar Array, 566, 575
- Polar Coordinates, 252
- Polar Tracking Mode, 279
- Polygon, 478
  - Creating, 478
- Polygonal Viewport, 1561
- Polyline, 470
  - Creating, 470
  - Editing, 533, 552
- Polyline Segments, 540
- Polysolid, 1103

- PRECISION, 272
- Precision Modes, 272
  - Grid, 273
  - Object Snap, 282
  - Object Snap Tracking, 295
  - ORTHO, 299
  - Polar Tracking, 279
  - Raster Snap, 291
  - Snap, 273
- PRECISION TOOLS, 272
- Presspull, 1128
- Printable Layers, 414
- Profiles
  - Create, 172
  - Manage, 172
- Program Emulation OpenGL, 179
- Program Installation, 31
- Program Modules, 30
  - Configuration, 30
- Program Registration, 31
- Properties Bar, 377
- Properties of the Sheet Set, 1617
- Proxy
  - Explode, 640
  - Remove, 639
- Proxy Objects, 639
- PTS, 1356
- PTX, 1355
- PUBLISH Command, 1592
- Purge, 125
- Purging a Document Using the Command Line, 127
- Pyramid, 1042, 1095
- Quick Access Toolbar, 37
- Quick Select Functional Bar, 519
- Quick Selection of Objects, 514
  - Quick Select Functional Bar, 519
- Radial, 1293
- Radial Dimensioning, 891
- Raster
  - New, 711
  - New Image from Selection, 705
  - Rasterization, 705
  - Save Objects to a File, 709
- Raster Background Transparency, 716
- Raster Floodfilling, 769
- Raster Image
  - Background Transparency, 716
  - Calibration, 727
  - Changing Resolution, 718
  - Correcting Geometry, 717
  - Correction by 4 Points, 724
  - Deskew, 723
  - Eliminating Deformations, 761
  - Floodfilling, 769
  - Mirror, 722
  - Pixel Drawing, 768
  - Rasterization, 767
  - Resizing, 717
  - Rotate, 722
  - Save Screenshot to a File, 710
  - Setting Options, 713
- Raster Images Boundary, 678
- Raster Snap, 291
- Rasterizaion, 705
- Rasterization, 767, 768
- Rasterization with Source Erasing, 767
- Ray, 467
- RCP, 1358
- RCS, 1358
- Rebuild 3D model, 1087
- Recalculation of Coordinates by EPSG Codes, 1405
- Recalculation of Point Cloud Coordinates by EPSG, 1360
- ReCap RCP, 1358
- ReCap RCS, 1358
- Recovery of Document, 125
- Rectangle
  - by Three Points, 484
  - by Two Points, 479
  - from Center, 481

- Rectangular Array, 562, 574
- Rectangular boundary, 677
- Rectangular Viewport, 1560
- Redefine plane for sketch, 1065
- Redefining
  - Block, 615
- Redefining Parameters, 1034
- Redefinition of Layer Properties in Viewports, 412
- Redo, 64
- Redo Isolation Step, 348
- Redrawing, 376
- Reference to Underlay, 670
- Regenerate, 1037
- Regeneration, 375
- Region, 814
- Registration of the Program, 31
- Regular Expressions of Search in the Script Editor, 1637
- Remove from Selection, 508
- Removing Layers, 407
- Removing Objects from Selection, 513
- Removing Objects from the Working Set, 647
- Removing Proxy Objects, 639
- Renaming Layers, 407
- Renaming Layout, 1556
- Renaming Named Objects, 665
- Reports
  - Creating, 1002
  - Grouping Cells, 1012
  - Merging Cells, 1009
- Reset All Clips Point Clouds, 1381
- Reset Block, 636
- Resizing Raster Image, 717
- Restore UI State, 68
- Restoring Dimension, 904
- Return to Previous File Versions, 90
- Reverse, 549
- Revision Cloud, 817
- Revolve, 1110
- Rib, 1196
- Ribbon, 37, 183
- Right Button Settings, 64
- Rotate, 582
- Rotate a Raster, 722
- Ruled shell, 1146
- Save as Geounderlay, 1547
- Save Objects to a File, 709
- Save Screen Shot to a File, 710
- Save to Measurement Archive, 1545
- Saving
  - Block in a Separate File, 87
  - Document, 83
  - Document with Another Name, 85
  - External Reference Changes, 647
  - Layout as a Template, 1554
- Saving a Block in a Separate File, 637
- Saving and Transferring Settings to Another Computer, 238
- Saving File History, 90
- Scale, 244, 583
  - for Dimensions, 875
  - Measurement, 246
  - Symbol, 245
  - Toolbar, 248
- Scale List, 241
- SCR, 1628
  - Editor, 1632
- Script Editor, 1632
  - Find and Replace, 1636
  - Options, 1633
  - Regular Expressions, 1637
- Script Editor Options, 1633
- Searching and Replacing Text, 855
- Section, 1120, 1253, 1261, 1264, 1265
- Section Note, 943
- Section Plane, 1253
- Select Color, 396
- Select Color Dialog Box, 396
- Selection Dialog, 510
- Selection of Objects

- Invert, 509
- Selection of Objects, 503
  - All, 508
  - Leave, 508
  - Remove, 508
  - Using the Command Line, 506
- Selection of Objects
  - Overlaid, 510
- Selection of Objects
  - Dialog, 510
- Selection of Objects
  - Using the Properties Bar, 512
- Selection of Objects
  - Remove from Selection, 513
- Selection of Objects
  - Quick Selection, 514
- Selection of Objects
  - Quick Select Functional Bar, 519
- Send Backward, 344
- Send to Back, 344
- Separate Raster Image, 711
- Set of Layouts, 1613
- Set of Views, 1614
- Set Sketch Coordinate System, 1066
- Set Variable Command, 1026
- Setting
  - Custom Paper Formats, 1579
  - Show Boundary for a Raster Image, 678
  - Show Boundary for a Viewport, 1566
  - UCS for Viewports, 271
  - Variable, 1026
  - Views, 314
- Setting Raster Options, 713
- Settings
  - Exporting User Interface, 146
  - Image, 713
  - Importing User Interface, 148
  - Layers' Profiles, 232
  - Right Button, 64
  - Saving and Transferring, 238
  - Transferring User Interface, 146
- Settings Migration, 145
- Shape, 812
- Sheet, 1616
- Sheet selection, 1616
- Sheet Set, 1606
  - Actions, 1622
  - Blocks, 1621
  - Callout Blocks, 1622
  - Custom Properties, 1619
  - Functional Bar, 1612
  - Label Blocks for Views, 1621
  - New, 1606
  - Open, 1612
  - Properties, 1617
  - Tree Elements, 1616
- Sheet Set Manager
  - Interface, 1615
- Sheet Set Manager Functional Bar, 1612
- Sheet solid, 1139
- Sheet subset, 1616
- Shell, 1143
- Show Clip
  - OFF, 673
- Show/hide constraints, 1308
- Showing All Features, 1390
- Showing Boundary, 672
- Sign External File, 1604
- Sign File, 1603
- Simplify text mode, 179
- Simplifying the Mesh, 1445
- Size and Style of Points, 466
- Slice, 1118
- Smart Trim, 544
- Smooth, 1278
- Snap mode, 274
- Snap to Feature, 1362
- Snap to Point Clouds, 1362
- Software Extensions, 1628
- Solid, 815

- Solid editing, 1135
- Solid Editing, 1203, 1207, 1209, 1211, 1214, 1217, 1230, 1231, 1232, 1234
- Spellchecker, 852
- Sphere, 1041, 1094
- Spline
  - Creating, 495
  - Editing, 554
- Spotlight, 1311
- Stamp, 1187
- Status Bar, 65
  - Display Elements, 67
- STL, 100
- Strength Analysis in CAE Fidesys, 103
- Stretch, 585
- Subtract, 1232
- Supported Formats of Point Cloud Files, 1353
- Surfaces, 1038
- Sweep, 1115
- Switch Point Cloud Boundary, 1361
- Symbol Scale, 245
- Symmetric, 1282
- Symmetry 3D Constraint, 1246
- System Requirements, 30
- System Variable Monitor, 248
- System Variables, 248
- Table Edit Dialog Box, 969
- Table Editor, 969
- Table of Layers Dialog Box, 232
- Tables
  - cell Properties, 984
  - Cell Properties, 977
  - Converting, 984
  - Creating, 960
  - Data Exchange with MS Excel, 979
  - Editing in the Dialog Box, 969
  - Editing on the Drawing, 967
  - Editing the Size of Rows and Columns, 978
  - Expression Builder, 996
  - Inserting Material, 1013
  - Page Division, 980
  - Reports, 1002
- Tables dwg
  - Styles, 1016
- Tangent, 1277
- Tangent 3D Constraint, 1244
- Template Usage, 71
- Terrasolid BIN, 1354
- Text, 818
  - Arc, 847
  - Background Mask, 830
  - Changing Case, 866
  - Editing, 832, 840
  - Explode, 865
  - Field, 868
  - Finding and Replacing, 860
  - Fit, 865
  - Justify, 861
  - Justifying, 833
  - Multiline, 822
  - Searching and Replacing, 855
  - Single-Line, 819
  - Spellchecker, 852
- Text Encoding Conversion, 129
- Text Styles, 850
- Texts and Dimensions to Front, 345
- Texts to Front, 344
- Texture Editor, 1321
- Thaw All Layers (Tools to Work with Layers), 449
- Thicken, 1127
- TIFF Saving Options, 658
- TIN
  - Converting to Meshes or 3D Faces, 1442
- Tool, 1324
- Tool Palettes, 1324
- Toolbars
  - Create, 193
- Topographic Scale, 1491
- topoplan, 1402

- Topoplan
  - New Topoplan, 1403
  - Recalculation of Coordinates by EPSG, 1405
- topoplan module, 1402
- Torus, 1042, 1100
- Trademarks, 27
- Transferring User Interface Settings, 146
- Transform, 1250, 1251
- Transformation to Default Coordinates, 1359
- Transmittal Package Creation, 104
- Trim Vectors, 542
- Tuning
  - Migration of Settings, 145
  - Program Parameters, 149
- Turn on All Layers (Tools to Work with Layers), 446
- TXT, 1357
- UCS, 254
  - Aligning to an Object, 257
  - Changing the Position from the Command Line, 255
  - for Viewports, 271
  - Icon, 265
  - Named, 266
- UCS Settings, 270
- Unbend, 1176
- Underlay, 670
  - Showing Boundary, 682
- Underlays
  - Insert, 670
  - Map, 684
- Undo, 61
- Undo Clip Point Clouds, 1381
- Undo Isolation Step, 347
- Undo-Redo Commands, 61
- Union, 1230
- Unisolate Objects, 348
- Unlock Layer (Tools to Work with Layers), 449
- Unrestricted Section of Point Cloud, 1382
- Update All OLE-Links, 669
- Update Fields, 873
- Update OLE-Links, 669
- User Coordinate Systems
  - Changing UCS Position, 255
- User-Defined Properties of Geopoints, 1411
- Using Dimensional Constraints, 1301
- Utilities, 122
  - Audit Geometry, 123
  - Batch File Processing, 134
- Validate Digital Signature, 1603, 1604
- Value Picker Dialog Box, 1023
- Variable, 1026
  - Set, 1026
- Variables, 248
- VBScript
  - Editor, 1632
  - Loading, 1630
- VBS-Editor, 1632
- Vectors
  - Breaking, 547
  - Extending, 546
  - Smart Trimming, 544
  - Trimming, 542
- Vertical, 1272, 1291
- Vertical Dimensioning, 878
- Vertical Section of Point Cloud, 1383
- Video Subsystem Performance Check, 175
- View, 1616
- View Mode
  - Zoom, 309
- View Mode of Layers, 415
- View Mode of Point Cloud, 1363
- View Modes
  - Pan, 308
  - Realtime, 310
  - Window, 311
  - Zoom 1
    - 1, 311
- Viewing Selected Layers, 415
- Viewports, 1559

- Align, 1565
  - by Object, 1562
  - Editing, 537
  - Named, 357, 360
  - of Model Space, 353
  - Polygonal, 1561
  - Rectangular, 1560
  - Setting UCS, 271
  - Showing Boundary, 1566
- Views
  - Isometric, 318
  - Named, 339
  - Orthographic, 314
- Virtual Command, 206
- Visual Style, 69
- Visual Styles, 361, 365
- Visual Styles Manager, 365
- VP Freeze Layer in All Viewports Except Current, 448
- Walk, 328
- Ways to Edit Objects, 520
  - by
    - WBLOCK Command, 87
    - WCS, 328
    - Weblight, 1314
    - Wedge, 1039, 1098
    - Width of lines on the screen, 338
    - Windows placing, 68
    - Wipeout, 816
    - Work with DBMS-Based Point Cloud Storage, 1347
- Working
  - with Commands, 58
  - with documents, 70
  - with Text, 818
- Working with raster images, 702
- Workspace Managing, 68
- World Coordinate System, 255
- Xedges, 1130
- XYB, 1357
- XYZ, 1357
- Zoom, 309
- Zoom after Import, 1362